

C A T A L O G O

DOMAL SUNNY

LE PERSIANE E GLI SCURONI
Della Tradizione Italiana

Hydro
Building
Systems



INDICE GENERALE

DESCRIZIONE	a pag.
INDICE GENERALE	1
NOTE GENERALI	3
CONSIGLI PRATICI	4
DOMALSUNNY P60	5
DOMALSUNNY FIORENTINA	129
DOMALSUNNY SCURONI	175
DOMALSUNNY VENETA	203
DOMALSUNNY GENOVESE	233
DOMALSUNNY XXMIGLIA	267
IDEAL GELOSIA	297
DOMALSUNNY PIACENTINA	323
INDICE PROFILI	337
INDICE ACCESSORI	338

RISTAMPA GIUGNO 2003

CATALOGO GRATUITO NON DESTINATO ALLA VENDITA.

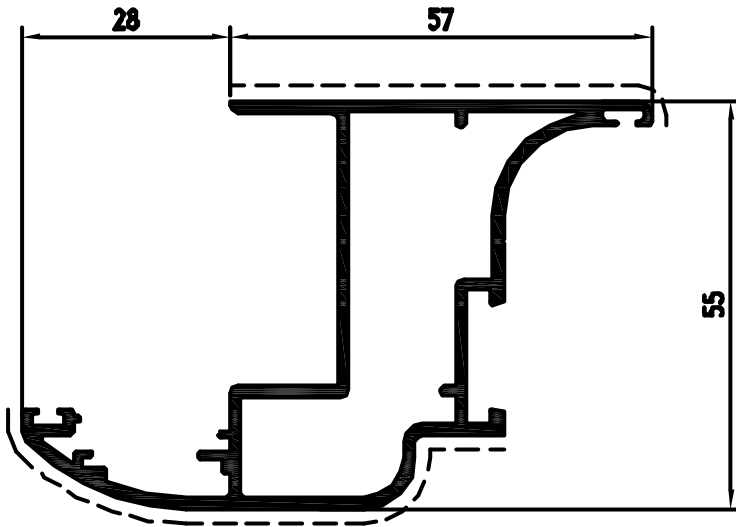

Pr. 34636 kg/m. 1.131
sup. in vista mm. 138

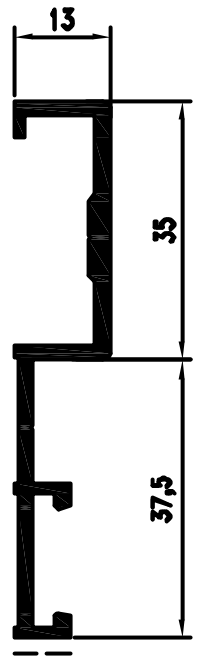

Pr. 34637 kg/m. 0.613
sup. in vista mm. 7.5

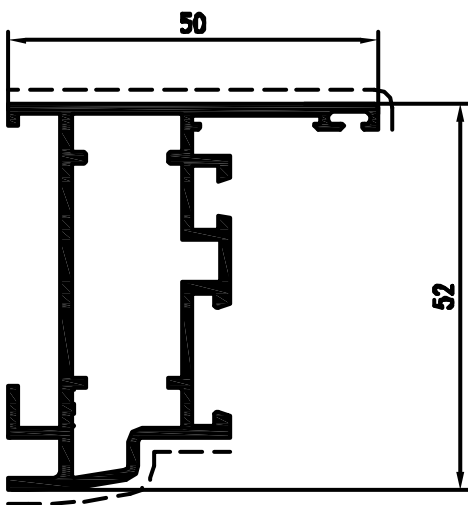

Pr. 60048 kg/m. 0.867
sup. in vista mm. 88

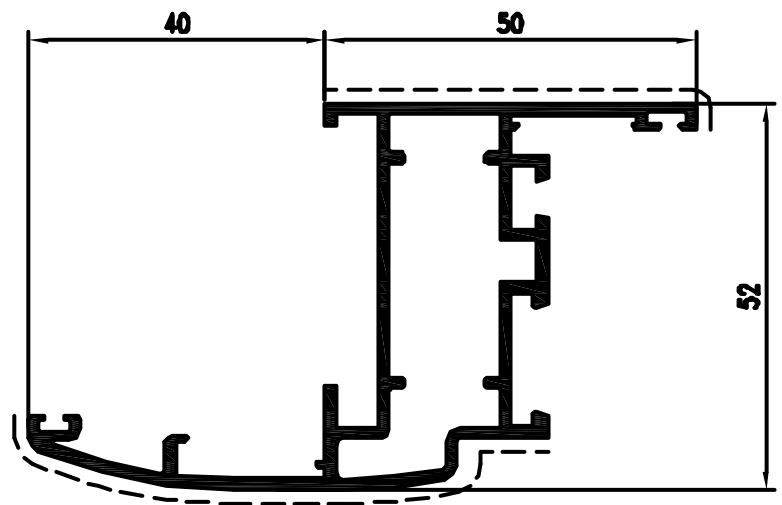

Pr. 60058 kg/m. 1.098
sup. in vista mm. 133

CONSIGLI PRATICI PER:

- ✓ LAVORAZIONE
- ✓ PROTEZIONE
- ✓ PULIZIA
- ✓ MANUTENZIONE

DELL'ALLUMINIO VERNICIATO ED OSSIDATO

1. **IMBALLAGGIO** . Impiegare la giusta protezione, evitando di esporre il profilo protetto direttamente ai raggi solari. In ogni caso il prodotto impiegato per eventuali reimpballi deve essere compatibile con la verniciatura o l'ossidazione ed occorre seguire le istruzioni del fornitore.
2. **LAVORAZIONE** . Durante tutte le fasi di lavorazione manovrare i profilati con estrema delicatezza ed accertarsi che l'ambiente di lavoro sia sempre pulito. Usare la massima cura nella movimentazione dei pezzi, evitando il contatto con scorie o residui di limature provenienti da lavorazioni precedenti.
3. **ATTREZZATURE** . Accertarsi che i macchinari utensili siano sempre efficienti ed adatti al compito da svolgere, in particolare le lame e le troncatrici, per il raffreddamento degli utensili evitare di utilizzare prodotti che possono intaccare la colorazione dei profilati e pregiudicarne la qualità.
4. **SIGILLATURA** . Sigillare accuratamente con prodotti idonei tutti i tagli e/o fori di lavorazione del serramento, bloccando perfettamente ogni zona soggetta ad infiltrazione. Accertarsi sempre che ci sia un corretto drenaggio all'interno dello scatolato del serramento.
5. **ACCESSORI** . Utilizzare esclusivamente accessoristica di ottima qualità. La viteria deve essere in materiale adatto e, possibilmente, isolato. Ricordare sempre che tutto ciò che non è alluminio, ma in contatto con quest'ultimo, può creare problemi di corrosione. Evitare l'uso delle squadrette in ferro non opportunamente trattate.
6. **LUBRIFICANTI** . Eseguire con particolare attenzione ed appositi olii la lubrificazione dell'accessoristica.
7. **POSA IN OPERA** . La buona norma richiede sempre di installare per ultimo il serramento in alluminio, evitando in questo modo possibili inconvenienti dovuti al contatto con sostanze presenti in cantiere che possono danneggiare le superfici verniciate o anodizzate.
Il montaggio del serramento deve essere eseguito ad opere murarie asciutte.
8. **MANUTENZIONE E PULIZIA** . Per mantenere il più possibile inalterate nel tempo le superfici anodizzate o verniciate, è necessario che le stesse vengano opportunamente pulite con prodotti appositi.

Le caratteristiche di tali prodotti, unitamente frequenza delle operazioni di pulizia da eseguire scrupolosamente, sono definite nei progetti di norma UNIMET E12.04.270.0 ed E12.04.277.0

In ogni caso si raccomanda vivamente di:

- Pulire le superfici quando non sono esposte a fonti di calore diretto, ad esempio i raggi solari.
- Usare per la pulizia una spugna o un panno morbido bagnato con l'apposito detergente.
- Il detergente deve essere: neutro, non abrasivo, non a base di ammoniaca, non a base di cloro (ad esempio candeggina).
- Le parti meccaniche debbono essere: pulite ed oliate tramite spray al silicone oppure al teflon e controllate anche a livello di usura.

La HYDRO ALUMINIUM SYSTEMS S.P.A. fornisce prodotti con finiture garantite dai marchi QUALANOD e QUALICOAT.

DOMAL SUNNY P.60



INDICE SUNNY P60

DESCRIZIONE	da pag.	a pag.
INDICE		7
DESCRIZIONE TECNICA DEL SISTEMA		9
KIT PERSIANE ORIENTABILI	11	13
ACCESSORI	14	50
SAGOMARIO PROFILATI	51	58
PROFILATI 1:1	59	77
SCHEMI E DISTINTE	79	92
SEZIONI 1:1	93	116
LAVORAZIONI	117	128

DESCRIZIONE TECNICA DEL SISTEMA

Profilati estrusi lega: EN AW-6060

Stato di fornitura: T5

Tolleranze dimensionali e spessori: EN 12020/2

Tipo di oscuramento:

- A lamelle fisse aperte (30°)
- A lamelle fisse cieche
- A lamelle orientabili

Tipo di lamelle:

- Ovalina 50 x 10 oppure 65 x 10 (lamelle fisse)
- Orientabile liscia (70 x 13,2)
- Orientabile a goccia (70 x 16,7)

Dimensioni base:

- BATTENTI
 - Telai: Abbinamento con DOMAL STOPPER PG/DOMAL 40/DOMAL GARDEN
 - Ante: Profondita' 40 mm - 52 mm
- STORICA
 - Ante: Profondita' 45 mm
- SCORREVOLE
 - Ante: Profondita' 40 mm
- A LIBRO
 - Ante: Profondita' 40 mm

Impiego: E' possibile realizzare persiane (finestre o porte) con oscuramento totale (fisso cieco) parziale (fisso aperto) o con meccanismo di apertura e chiusura delle lamelle (orientabile) nelle seguenti tipologie di apertura.

- BATTENTE - Finestre - porte ad 1-2 o piu' ante
 - " " con inserita apertura "alla genovese"
- STORICA - Per ristrutturazione di finestre porte ad 1-2 o piu' ante
- SCORREVOLE - Finestre - porte ad 1-2 o piu' ante
- A LIBRO - In abbinamento al DOMAL GARDEN

"PIANA" Pr. 27366

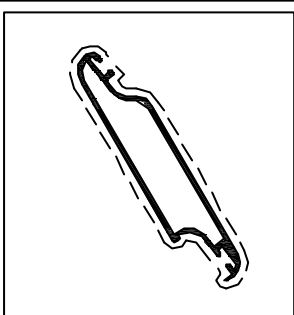

KIT Persiane Orientabili

GARANZIA DI 10 ANNI
per la movimentazione

Richiedi il certificato presso il tuo C.D.

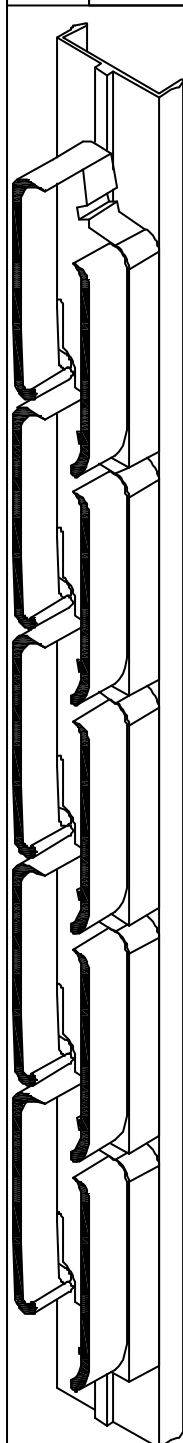

CODICE	DESCRIZIONE	MISURA Kit	LUCE INTERNA ANTA	
			LUCE minima	LUCE massima
SP K 06	Meccanismo di movimentazione 6 lamelle	349	411	470
SP K 07	Meccanismo di movimentazione 7 lamelle	409	471	530
SP K 08	Meccanismo di movimentazione 8 lamelle	469	531	590
SP K 09	Meccanismo di movimentazione 9 lamelle	529	591	650
SP K 10	Meccanismo di movimentazione 10 lamelle	589	651	710
SP K 11	Meccanismo di movimentazione 11 lamelle	649	711	770
SP K 12	Meccanismo di movimentazione 12 lamelle	709	771	830
SP K 13	Meccanismo di movimentazione 13 lamelle	769	831	890
SP K 14	Meccanismo di movimentazione 14 lamelle	829	891	950
SP K 15	Meccanismo di movimentazione 15 lamelle	889	951	1010
SP K 16	Meccanismo di movimentazione 16 lamelle	949	1011	1070
SP K 17	Meccanismo di movimentazione 17 lamelle	1009	1071	1130
SP K 18	Meccanismo di movimentazione 18 lamelle	1069	1131	1190
SP K 19	Meccanismo di movimentazione 19 lamelle	1129	1191	1250
SP K 20	Meccanismo di movimentazione 20 lamelle	1189	1251	1310
SP K 21	Meccanismo di movimentazione 21 lamelle	1249	1311	1370
SP K 22	Meccanismo di movimentazione 22 lamelle	1309	1371	1430
SP K 23	Meccanismo di movimentazione 23 lamelle	1369	1431	1490
SP K 24	Meccanismo di movimentazione 24 lamelle	1429	1491	1550
SP K 25	Meccanismo di movimentazione 25 lamelle	1489	1551	1610
SP K 26	Meccanismo di movimentazione 26 lamelle	1549	1611	1670
SP K 27	Meccanismo di movimentazione 27 lamelle	1609	1671	1730
SP K 28	Meccanismo di movimentazione 28 lamelle	1669	1731	1790
SP K 29	Meccanismo di movimentazione 29 lamelle	1729	1791	1850
SP K 30	Meccanismo di movimentazione 30 lamelle	1789	1851	1910
SP K 54	Meccanismo di movimentazione 54 lamelle (da tagliare)			3350

"GOCCIA" Pr.27367

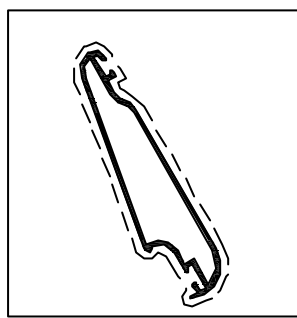

KIT Persiane Orientabili

GARANZIA DI 10 ANNI
per la movimentazione

Richiedi il certificato presso il tuo C.D.

"RUSTICA" Pr.27368

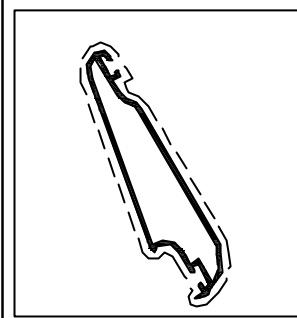

CODICE	DESCRIZIONE	MISURA Kit	LUCE INTERNA ANTA	
			LUCE minima	LUCE massima
SG K 06	Meccanismo di movimentazione 6 lamelle	349	411	470
SG K 07	Meccanismo di movimentazione 7 lamelle	409	471	530
SG K 08	Meccanismo di movimentazione 8 lamelle	469	531	590
SG K 09	Meccanismo di movimentazione 9 lamelle	529	591	650
SG K 10	Meccanismo di movimentazione 10 lamelle	589	651	710
SG K 11	Meccanismo di movimentazione 11 lamelle	649	711	770
SG K 12	Meccanismo di movimentazione 12 lamelle	709	771	830
SG K 13	Meccanismo di movimentazione 13 lamelle	769	831	890
SG K 14	Meccanismo di movimentazione 14 lamelle	829	891	950
SG K 15	Meccanismo di movimentazione 15 lamelle	889	951	1010
SG K 16	Meccanismo di movimentazione 16 lamelle	949	1011	1070
SG K 17	Meccanismo di movimentazione 17 lamelle	1009	1071	1130
SG K 18	Meccanismo di movimentazione 18 lamelle	1069	1131	1190
SG K 19	Meccanismo di movimentazione 19 lamelle	1129	1191	1250
SG K 20	Meccanismo di movimentazione 20 lamelle	1189	1251	1310
SG K 21	Meccanismo di movimentazione 21 lamelle	1249	1311	1370
SG K 22	Meccanismo di movimentazione 22 lamelle	1309	1371	1430
SG K 23	Meccanismo di movimentazione 23 lamelle	1369	1431	1490
SG K 24	Meccanismo di movimentazione 24 lamelle	1429	1491	1550
SG K 25	Meccanismo di movimentazione 25 lamelle	1489	1551	1610
SG K 26	Meccanismo di movimentazione 26 lamelle	1549	1611	1670
SG K 27	Meccanismo di movimentazione 27 lamelle	1609	1671	1730
SG K 28	Meccanismo di movimentazione 28 lamelle	1669	1731	1790
SG K 29	Meccanismo di movimentazione 29 lamelle	1729	1791	1850
SG K 30	Meccanismo di movimentazione 30 lamelle	1789	1851	1910
SG K 54	Meccanismo di movimentazione 54 lamelle (da tagliare)			3350



KIT Persiane Orientabili

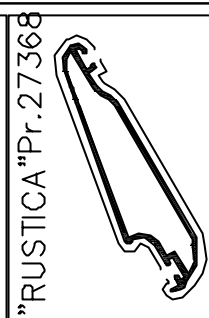

CODICE
SP K 06
SP K 07
SP K 08
SP K 09
SP K 10
SP K 11
SP K 12
SP K 13
SP K 14
SP K 15
SP K 16
SP K 17
SP K 18
SP K 19
SP K 20
SP K 21
SP K 22
SP K 23
SP K 24
SP K 25
SP K 26
SP K 27
SP K 28
SP K 29
SP K 30
SP K 54

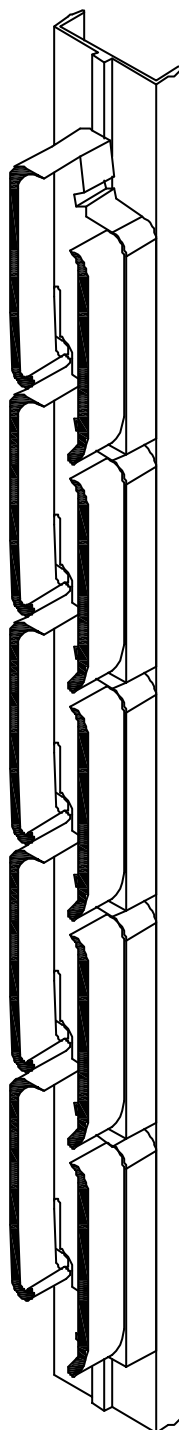



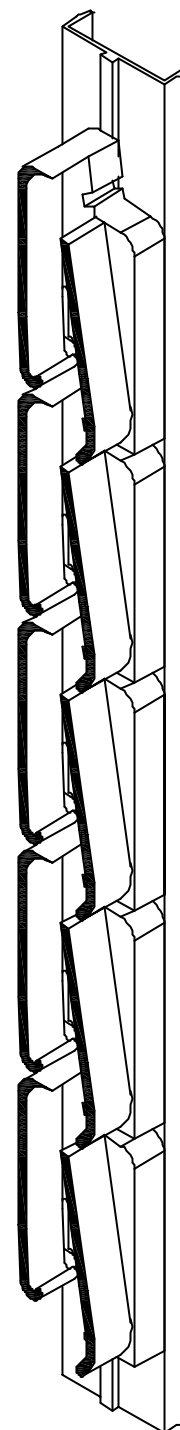

COLORE
NERO
RAL 1013
RAL 6005
RAL 7100
RAL 7200
*RAL 7300
RAL 8001P
RAL 8017
RAL 9010





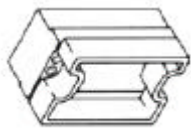

*Non disponibile a stock.
Solo su ordinazione.

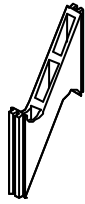
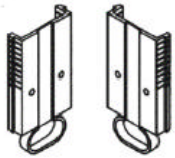
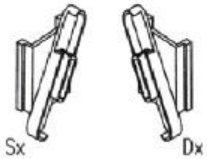

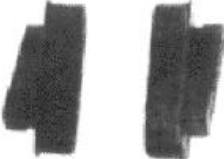

CODICE
SG K 06
SG K 07
SG K 08
SG K 09
SG K 10
SG K 11
SG K 12
SG K 13
SG K 14
SG K 15
SG K 16
SG K 17
SG K 18
SG K 19
SG K 20
SG K 21
SG K 22
SG K 23
SG K 24
SG K 25
SG K 26
SG K 27
SG K 28
SG K 29
SG K 30
SG K 54





ACCESSORI	CODICE	COLORE	DESCRIZIONE	MATER.	CONFEZ.
	04 A 21	GREZZO	SQUADRETTA PRESSOFUSA A SCATTO PER Pr 24451 - 24455 E D. 40	ALLUMINIO	PEZZI 250
	04 A 22	GREZZO	SQUADRETTA PRESSOFUSA A SCATTO CON TIRAGGIO ESTERNO	ALLUMINIO	PEZZI 250
	04 A 24	GREZZO	SQUADRETTA AD ANGOLAZIONE VARIABILE	ALLUMINIO	PEZZI 20
	30 B 01	GREZZO RAL6005 RAL9005	CERNIERA PER APERTURA ALLA "GENOVESE"	ALLUMINIO	COPPIE 100
	30 C 91	NERO	CRICCHETTO PER APERTURE ALLA "GENOVESE"	NYLON	PEZZI 2
	30 D 04	NERO	TAPPO PER FASCIA Pr 16013-26210	NYLON	PEZZI 50



ACCESSORI	CODICE	COLORE	DESCRIZIONE	MATER.	CONFEZ.
	30 D 05	NERO	TAPPO PER FASCIA Pr 16012	NYLON	PEZZI 50
	30 D 06	NERO RAL 1013 RAL 6005 RAL 7100 RAL 7200 RAL 7300 RAL 8001P RAL 8017 RAL 9010	TAPPO CHIUDI TUBOLARITA' PER PROFILATO ROMPITRATTA Pr.27374	NYLON	PEZZI 20
	30 D 20	GREZZO	SELLA REVERSIBILE IN ALLUMINIO PER Pr 10763	ALLUMINIO	PEZZI 200
	30 D 21	NERO RAL6005	SELLA REVERSIBILE PER Pr 13199	NYLON	PEZZI 500
	30 D 22	NERO RAL1013 RAL6005 RAL8017 RAL9010	SELLA REVERSIBILE PER Pr 10763-50013	NYLON	PEZZI 500
	30 D 23	NERO	COMPENSATORI PER Pr 10763-13199 GELOSIA A LAMELLE FISSE A 30°	NYLON	PEZZI 100
	30 D 24	NERO	TAPPO DX E SX PER Pr 13199 GELOSIA A LAMELLE FISSE A 30°	NYLON	COPPIE 50



ACCESSORI	CODICE	COLORE	DESCRIZIONE	MATER.	CONFEZ.
	30 D 25	NERO	TAPPO DX E SX PER Pr 10763 GELOSIA A LAMELLE FISSE A 30°	NYLON	COPPIE 100
	30 D 26	NERO	TAPPO DX E SX PER Pr 13199 GELOSIA A LAMELLE FISSE A 30°	NYLON	COPPIE 100
	30 D 29	NERO	GELOSIA A LAMELLE FISSE A 30° TAPPO DX E SX PER Pr 10763	NYLON	COPPIA 100
	30 D 43	NERO	FERMAGELOSIA A SCATTO	PLASTICA	PEZZI 10
	30 D 44	NERO	FERMO IMPOSTA AUTOMATICO "GRILLO"	NYLON	PEZZI 10
	30 D 48	NERO	FERMAGELOSIA A SCATTO CON AMORTIZZATORE "GRILLO"	NYLON	PEZZI 10
	30 D 79	NERO	BRACCETTO PER APERTURA ALLA "GENOVESE"	ALLUMINIO	PEZZI 100

ACCESSORI	CODICE	COLORE	DESCRIZIONE	MATER.	CONFEZ.
	30 D 84	NERO	TAPPI PER OVALINA Pr 10763 FISSA CHIUSA	NYLON	COPPIE 200
	60 C 50	RAL1013 RAL6005 RAL8017 RAL9005 RAL9010	CREMONESE "MANON" CON CHIAVE PER APERTURE ESTERNE	PRESSO- FUSO	PEZZI 10
	FAP1872	RAL9005 RAL9010	CREMONESE MANICO BASSO	ALLUMINIO	PEZZI 10
	FAP1892AX	GREZZO	TERMINALE INOX DIRITTO	ACC. INOX	PEZZI 50
	FAP1892BX	GREZZO	TERMINAL INOX PIEGATO	ACC. INOX	PEZZI 50
	FAP1893A	RAL9005 RAL9010	INCONTRO IN ZAMA	ZAMA	PEZZI 10
	FAP1895	GREZZO	BUSSOLA PER SOGLIA	ACC. INOX	PEZZI 50

ACCESSORI	CODICE	COLORE	DESCRIZIONE	MATER.	CONFEZ.
	62 D 0L	RAL9005 RAL9010	ASTE L 1400mm PER CREMONESE 62 C 0L	ALLUMINIO	PEZZI 1
	62 D 10	GREZZO RAL VARI	STECCA PRETRANCIATA PER OVALINA 50 x 10	ALLUMINIO	COPIA 1
	71 C 73	VER.NAT. RAL1013 RAL6005 RAL8017 RAL9005 RAL9010	CREMONESE "MAXIMA" PER APERTURE INTERNE/ESTERNE	ZAMA	PEZZI 10
	80 D 17	GREZZO	BUSSOLA A PAVIMENTO PER RISCONTRO TERMINALE ASTE DI CHIUSURA	OTTONE	PEZZI 30
	80 D 35	NERO	TAPPO CHIUDIFORO DIAMETRO 11,5mm	PVC	PEZZI 1000
	97 V 91	NERO	TASSELLO DI REGOLAZIONE MAGGIORATO PER "MAXI GRILLO"	NYLON	PEZZI 100
	97 V 92	NERO	FERMO IMPOSTA "MAXI GRILLO"	NYLON	PEZZI 10
	ES 0690	NERO	SPESSORE DA mm. 7,5 PER "MAXI GRILLO"	NYLON	PEZZI 30

ACCESSORI	CODICE	COLORE	DESCRIZIONE	MATER.	CONFEZ.
	SG D 01	NERO RAL 1013 RAL 6005 RAL 7100 RAL 7200 RAL 7300 RAL 8001P RAL 8017 RAL 9010	COMPENSATORI PER LAMELLE A GOCCIA FISSE APERTE	NYLON	COPPIE 20
	SG D 10	NERO RAL 1013 RAL 6005 RAL 7100 RAL 7200 RAL 7300 RAL 8001P RAL 8017 RAL 9010	SELLE PER LAMELLE A GOCCIA FISSE APERTE	NYLON	PEZZI 100
	SG D 20	NERO RAL 1013 RAL 6005 RAL 7100 RAL 7200 RAL 7300 RAL 8001P RAL 8017 RAL 9010	TAPPI PER LAMELLE A GOCCIA FISSE CIECHE	NYLON	COPPIE 10
	SP D 01	NERO RAL 1013 RAL 6005 RAL 7100 RAL 7200 RAL 7300 RAL 8001P RAL 8017 RAL 9010	COMPENSATORI PER LAMELLE PIANE FISSE APERTE	NYLON	COPPIE 20
	SP D 10	NERO RAL 1013 RAL 6005 RAL 7100 RAL 7200 RAL 7300 RAL 8001P RAL 8017 RAL 9010	SELLE PER LAMELLE PIANE FISSE APERTE	NYLON	PEZZI 100

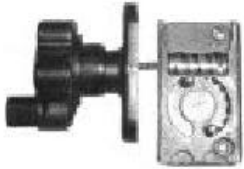
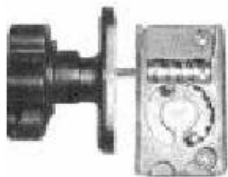
ACCESSORI	CODICE	COLORE	DESCRIZIONE	MATER.	CONFEZ.
	SP D 20	NERO RAL 1013 RAL 6005 RAL 7100 RAL 7200 RAL 7300 RAL 8001P RAL 8017 RAL 9010	TAPPI PER LAMELLE PIANE FISSE CIECHE	NYLON	COPPIE 10
	SU D 90	NERO RAL 1013 RAL 6005 RAL 7100 RAL 7200 RAL 7300 RAL 8001P RAL 8017 RAL 9010	COMPENSATORI PER LAMELLE FISSE CIECHE	NYLON	COPPIE 20
	SU G 01	NERO	GUARNIZIONE DI BATTUTA PER LAMELLE	EPDM	Mt. 500

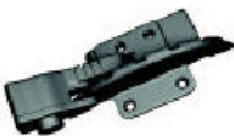
ACCESSORI	CODICE	COLORE	DESCRIZIONE	MATER.	CONFEZ.
	SU K 95	NERO RAL 1013 RAL 6005 RAL 7100 RAL 7200 RAL 7300 RAL 8001P RAL 8017 RAL 9010	MANIGLIA A ROTAZIONE AMBIDESTRA "MARGHERITA" CON POMELLO ESTRAIBILE * COMPRESI COMPENSATORI	ZAMA/OTT NYLON CARIC.F.V.	PEZZI 1
	SU K 96	NERO RAL 1013 RAL 6005 RAL 7100 RAL 7200 RAL 7300 RAL 8001P RAL 8017 RAL 9010	MANIGLIA A ROTAZIONE AMBIDESTRA "MARGHERITA" * COMPRESI COMPENSATORI	ZAMA/OTT NYLON CARIC.F.V.	PEZZI 1
	SU K 97	NERO RAL 1013 RAL 6005 RAL 7100 RAL 7200 RAL 7300 RAL 8001P RAL 8017 RAL 9010	MANIGLIA A ROTAZIONE AMBIDESTRA "GIRASOLE" CON TESTA RIBASSATA ESTRAIBILE (CONSIGLIATA PER PERSIANA ORIENTABILE SU DOMAL GARDEN) * COMPRESI COMPENSATORI	ZAMA/OTT NYLON CARIC.F.V.	PEZZI 1
	SU K 98	NERO RAL 1013 RAL 6005 RAL 7100 RAL 7200 RAL 7300 RAL 8001P RAL 8017 RAL 9010	MANIGLIA A LEVA "GRIP" CON BLOCCO DX NUMERO MAX LAMELLE MOVIMENTABILI = 20 * COMPRESI COMPENSATORI	NYLON CARIC.F.V.	PEZZI 1
	SU K 99	NERO RAL 1013 RAL 6005 RAL 7100 RAL 7200 RAL 7300 RAL 8001P RAL 8017 RAL 9010	MANIGLIA A LEVA "GRIP" CON BLOCCO SX NUMERO MAX LAMELLE MOVIMENTABILI = 20 * COMPRESI COMPENSATORI	NYLON CARIC.F.V.	PEZZI 1

SCELTA E CORRETTO IMPIEGO DELLA FERRAMENTA

- In fase di montaggio, assicurarsi del corretto serraggio delle viti e degli agganci tra i componenti. Sostituire immediatamente le parti usurate.
- **Non utilizzare** il martello per montare la ferramenta.
- **Non verniciare** la ferramenta dopo che è stata montata sulla persiana.
- **Non esporre** la ferramenta in ambienti soggetti ad agenti chimici aggressivi, come, ad esempio, locali chiusi con le sole persiane e soggetti a pulizia dei pavimenti o a lavorazioni che utilizzano solventi. La protezione viene meno se viene danneggiata la superficie protettiva in seguito a colpi, tagli o graffi o con l'utilizzo di detergenti abrasivi o a base di solventi.
- Il trattamento di protezione impiegato assicura alla ferramenta un'adeguata protezione contro gli agenti atmosferici. Le persiane che vengono montate in situazioni climatiche particolarmente aggressive (es: a contatto con la salsedine) richiedono ferramenta particolare.



ISTRUZIONI PER L'USO E LA SICUREZZA





- **Pericolo d'infortunio:** attenzione agli schiacciamenti.
- **Non applicare** carichi aggiuntivi alla persiana.
- **Non sbattere** la persiana. In caso di vento chiudere le persiane o vincolare le ante in posizione di apertura a 180° utilizzando gli appositi fermi.
- **Non frapporre** oggetti nello spazio di apertura.
- **Non forzare** i componenti. In caso di difficoltà di movimentazione accertarsi che non vi siano ostruzioni o disallineamenti nelle parti in movimento visibili.

MANUTENZIONE

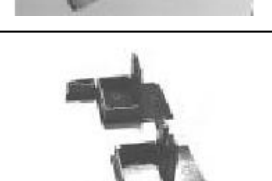
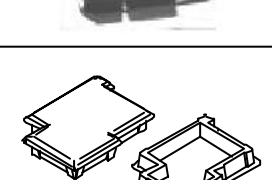





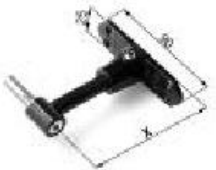

- **Pulire** con panno morbido asciutto. Non usare prodotti abrasivi o a base di solventi che compromettano la protezione anticorrosione.
- Verificare periodicamente lo stato di integrità della ferramenta, eliminando eventuali focolai di ossidazione. **Lubrificare** con spray silconico, almeno una volta l'anno, le parti in movimento. Non utilizzare olii o grassi.
- Se necessario, ripristinare il corretto uso della ferramenta effettuando le dovute **regolazioni**. Qualora si verifichi una cattiva scorrevolezza dell'anta o difficoltà nella chiusura con la spagnoletta, è consigliabile far controllare se la persiana ha subito cedimenti. Far registrare le cerniere, per riportare l'anta perfettamente in squadra e restituirle la perfetta funzionalità.

Attenzione: tutti gli interventi di regolazione dei meccanismi, la sostituzione di parti, lo sgancio e il riaggancio delle ante, devono essere effettuati da personale specializzato.

ACCESSORI	CODICE	COLORE	DESCRIZIONE	MATER.	CONFEZ.
	30 A 20	GREZZO	SQUADRETTA PRESSOFUSA A SCATTO PER ANTA Pr 27362	ALLUMINIO	PEZZI 250
	30 A 21	GREZZO	SQUADRETTA PRESSOFUSA A SCATTO PER ANTA Pr 27362 CON COMPONENTI IN ACCIAIO	ALLUMINIO	PEZZI 250
	30 D 74	NERO	TAPPO CHIUDI TUBOLARITA' PER ANTA 27362	NYLON	PEZZI 50
	33 D 01	NERO	TAPPO CHIUDI TUBOLARITA' Pr 24451	POLIPRO- PILENE	PEZZI 40
	33 D 02	NERO	TAPPO CHIUDI TUBOLARITA' INFERIORE PER STULP Pr 24452	NYLON	PEZZI 100

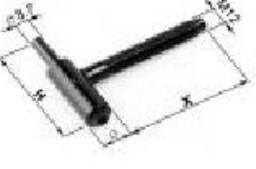





ACCESSORI	CODICE	COLORE	DESCRIZIONE	MATER.	CONFEZ.
			VERSIONE MONTAGGIO INTERNO MAZZETTA		
	30B110D 30B110S	GREZZO RAL9005 RAL8017 RAL6005	CARDINI DX-SX PER ANTA STORICA FISSAGGIO INTERNO	ALLUMINIO	PEZZI 20Dx PEZZI 20Sx
	30B111D 30B111S	GREZZO RAL9005 RAL8017 RAL6005	CARDINI DX-SX PER ANTA STORICA FISSAGGIO INTERNO CON PERNO REGOLABILE	ALLUMINIO	PEZZI 20Dx PEZZI 20Sx
	30B112	GREZZO RAL9005 RAL8017 RAL6005	CARDINE PER ANTA STORICA FISSAGGIO ESTERNO	ALLUMINIO	PEZZI 20
	30B113	GREZZO RAL9005 RAL8017 RAL6005	CARDINE PER ANTA STORICA FISSAGGIO ESTERNO CON PERNO REGOLABILE	ALLUMINIO	PEZZI 20
	30B114	GREZZO	KIT FISSAGGIO CARDINI	ALLUMINIO	KIT 20
	30B116	GREZZO	TAPPO DI SICUREZZA PER Cod. 30 B 110 Cod. 30 B 111 - 30 B 112 - 30 B 115	OTTONE- ACC.INOX	PEZZI 20
	30B120D 30B120S	GREZZO RAL9005 RAL8017 RAL6005	CARDINI DX-SX PER TERZA ANTA STORICA FISSAGGIO ESTERNO	ALLUMINIO	PEZZI 20Dx PEZZI 20Sx
	30B121	GREZZO RAL9005 RAL8017 RAL6005	CARDINI DX-SX A SQUADRO PER ANTA STORICA FISSAGGIO ESTERNO CON PERNO REGOLABILE	ALLUMINIO	COPIA 10

ACCESSORI	CODICE	COLORE	DESCRIZIONE	MATER.	CONFEZ.
	30 C 111	NERO	FERMO A MARMO	ZINCATO	PEZZI 200
	30 C 112	NERO	FERMO A VITE	ZINCATO	PEZZI 200

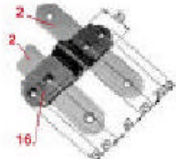
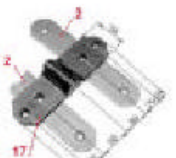
ACCESSORI	CODICE	COLORE	DESCRIZIONE	MATER.	CONFEZ.
	33B087	RAL9005	CARDINE REGOLABILE CON MENSOLA STRETTA SPALLA 62-70mm	ACCIAIO	PEZZI 20
	33B088	RAL9005	CARDINE REGOLABILE CON MENSOLA STRETTA SPALLA 67-125mm	ACCIAIO	PEZZI 20
	33B089	RAL9005	CARDINE REGOLABILE CON MENSOLA STRETTA SPALLA 97-190mm	ACCIAIO	PEZZI 20
	33B090	RAL9005	CARDINE REGOLABILE CON MENSOLA STRETTA SPALLA 145-225mm	ACCIAIO	PEZZI 20
	33B095	RAL9005	CARDINE 85mm REGOLABILE FISSAGGIO A TASSELLO	ACCIAIO	PEZZI 20
	33B096	RAL9005	CARDINE 125mm REGOLABILE FISSAGGIO A TASSELLO	ACCIAIO	PEZZI 20
	33B097	RAL9005	CARDINE 145mm REGOLABILE FISSAGGIO A TASSELLO	ACCIAIO	PEZZI 20
	33B098	RAL9005	CARDINE 175mm REGOLABILE FISSAGGIO A TASSELLO	ACCIAIO	PEZZI 20

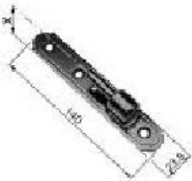
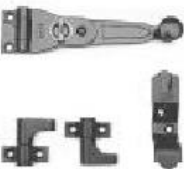
ACCESSORI	CODICE	COLORE	DESCRIZIONE	MATER.	CONFEZ.
	33B099 D	RAL9005	CERNIERA REGOLABILE 45x8 DX COLLO 45x26mm	ZAMA	PEZZI 20
	33B099 S	RAL9005	CERNIERA REGOLABILE 45x8 SX COLLO 45x26	ZAMA	PEZZI 20
	33B100 D	RAL9005	CERNIERA REGOLABILE 19x8 DX COLLO 19x26mm	ZAMA	PEZZI 20
	33B100 S	RAL9005	CERNIERA REGOLABILE 19x8 SX COLLO 19x26mm	ZAMA	PEZZI 20
	33B101	RAL9005	BANDELLA VERTICALE PER CERNIERA	ACCIAIO	PEZZI 20
	33B102	RAL9005	SQUADRO PER CERNIERA SUPERIORE SX. - INFERIORE DX.	ACCIAIO	PEZZI 20
	33B103	RAL9005	SQUADRO PER CERNIERA SUPERIORE DX. - INFERIORE SX.	ACCIAIO	PEZZI 20
	33B104	RAL9005	CERNIERA REGOLABILE COLLO 40mm	ZAMA	PEZZI 20

ACCESSORI	CODICE	COLORE	DESCRIZIONE	MATER.	CONFEZ.
 <small>Bucola minima 15 mm</small>	33B105	RAL9005	SUPPORTO CERNIERA PER Cod. 33B104 PER SQUADRI E BANDELLE	ZAMA	PEZZI 20
 <small>Bucola minima 15 mm</small>	33B106	RAL9005	SUPPORTO A FILO PER Cod. 33B104 PER SQUADRI E BANDELLE	ZAMA	PEZZI 20
	33B107	RAL9005	CERNIERA REGOLABILE COLLO 25mm	ZAMA	PEZZI 20
	33B108	RAL9005	CARDINE 85mm FISSAGGIO A TASSELLO	ACCIAIO	PEZZI 20
	33B109	RAL9005	CARDINE 125mm FISSAGGIO A TASSELLO	ACCIAIO	PEZZI 20
	33B110	RAL9005	CARDINE 145mm FISSAGGIO A TASSELLO	ACCIAIO	PEZZI 20
	33B111	RAL9005	CARDINE 175mm FISSAGGIO A TASSELLO	ACCIAIO	PEZZI 20
	33B112	RAL9005	CARDINE A MURARE	ACCIAIO	PEZZI 6

ACCESSORI	CODICE	COLORE	DESCRIZIONE	MATER.	CONFEZ.
	33B113	RAL9005	CERNIERA COMPLANARE DISASSATA PER SQUADRI /BANDELLE	ZAMA	PEZZI 20
	33B114	RAL9005	CERNIERA COMPLANARE SIMMETRICA PER SQUADRI/BANDELLE	ZAMA	PEZZI 20
	33B115	RAL9005	SPESSORE PER CERNIERE Cod. 33B105 - 33B106	ALLUMINIO	PEZZI 20
	33B119	RAL9005	CARDINE FISSO CON PIASTRINA DA 24mm PER Cod. 33B116	ALLUMINIO	PEZZI 20
	33C099	RAL9005	CONFEZIONE BASE SPAGNOLETTA GRANDE 2 ANTE	ZAMA	PEZZI 20
	33C100	RAL9005	CONFEZIONE BASE SPAGNOLETTA PICCOLA 2 ANTE (CONSIGLIATA NELLA PERSIANA CON LAMELLE ORIENTABILI)	ZAMA	PEZZI 20
	33C101	RAL9005	CONFEZIONE BASE SPAGNOLETTA PICCOLA 1 ANTA	ZAMA	PEZZI 20
	33C102	RAL9005	CONFEZIONE BASE SPAGNOLETTA A SCATTO	ZAMA	PEZZI 20





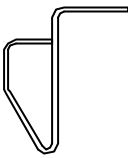
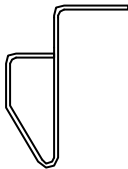

ACCESSORI	CODICE	COLORE	DESCRIZIONE	MATER.	CONFEZ.
	33C103	RAL9005	PERNO DI CHIUSURA DIRITTO	ACCIAIO	PEZZI 50
	33C104	RAL9005	PIASTRA DI CHIUSURA AD ANGOLO	ACCIAIO	PEZZI 20
	33C105	RAL9005	GUIDA ASTE	ZAMA	PEZZI 50
	33C106	RAL9005	CHIUSURA VERTICALE AD ESPANSIONE DX. CONFEZIONE BASE	ZAMA/ACC.	PEZZI 20
	33C107	RAL9005	CHIUSURA VERTICALE AD ESPANSIONE SX. CONFEZIONE BASE	ZAMA/ACC.	PEZZI 20
	33C108	RAL9005	COMPENSATORE DI ROTAZIONE 180° DX. PER Cod. 33C106	ZAMA	PEZZI 50
	33C109	RAL9005	COMPENSATORE DI ROTAZIONE 180° SX. PER Cod. 33C107	ZAMA	PEZZI 50
	33C110	RAL9005	POZZETTO PER SOGLIA	ZAMA	PEZZI 50

ACCESSORI	CODICE	COLORE	DESCRIZIONE	MATER.	CONFEZ.
	33C111	RAL9005	LAMA DI AGGANCIO PER IMPOSTA	ACCIAIO	PEZZI 20
	33C112	RAL9005	FERMOIMPOSTA AUTOMATICO A MURO	ZAMA	PEZZI 20
	33C114	RAL9005	BUSSOLE FILETTATE PER Cod. 33C115	ZAMA	PEZZI 100
	33C115	GREZZO	VITE 50mm PER Cod. 33C114	INOX	PEZZI 100
	33C116	RAL9005	ASTA DI CHIUSURA 1800mm	ACCIAIO	PEZZI 10
	33C117	RAL9005	ASTA DI CHIUSURA 2400mm	ACCIAIO	PEZZI 10
	33C118	RAL9005	ASTA DI CHIUSURA 3200mm	ACCIAIO	PEZZI 10
	33C130	RAL9005	PERNO DI CHIUSURA M8	ACCIAIO	PEZZI 50

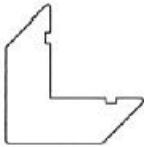
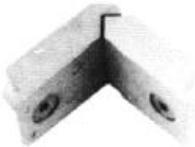

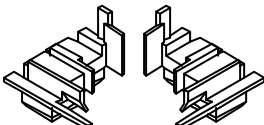

ACCESSORI	CODICE	COLORE	DESCRIZIONE	MATER.	CONFEZ.
	33C131	RAL9005	PERNO DI CHIUSURA Ø10 DA INCOLLARE	ACCIAIO	PEZZI 50
	33C132	RAL9005	PERNO DI CHIUSURA ECCENTRICO	ACC.-ABS	PEZZI 10
	33D100	RAL9005	ROSETTA COPRIFORO CARDINE	ABS	PEZZI 100
	33D101	GREZZO	TASSELLO 100mm	ABS	PEZZI 50
	33D102	GREZZO	TASSELLO 135mm	ABS	PEZZI 50
	33W100		KIT DIME PER IMPOSTE A MURARE	ACCIAIO	PEZZI 1

SEZIONE	CODICE	DESCRIZIONE	BOBINE m	SCATOLA m
	90 G 97	GUARNIZIONE PER BATTUTA "STORICA" MATERIALE: EPDM COLORE: NERO	250	250





ACCESSORI	CODICE	COLORE	DESCRIZIONE	MATER.	CONFEZ.
	13 A 41	GREZZO	SQUADRETTA PER CONTROTELAIO Cod. 13 D 92 e 69D92	ACCIAIO ZINCATO	PEZZI 300
	13 D 92	GREZZO	CONTROTELAIO PER PROFILATI SEZ. 45 mm. Kg/m 1.320	ACCIAIO ZINCATO	BARRA 5 m
	69 D 92	GREZZO	CONTROTELAIO PER PROFILATI SEZ. 52 mm. Kg/m 1.170	ACCIAIO ZINCATO	BARRA 5 m



ACCESSORI	CODICE	COLORE	DESCRIZIONE	MATER.	CONFEZ.
	13 A 03	GREZZO	SQUADRETTA DI ALLINEAMENTO PER Pr 27329 E Pr 27330	ALLUMINIO	PEZZI 250
	13 A 21	GREZZO	SQUADRETTA PRESSOFUSA A SCATTO	ALLUMINIO	PEZZI 250
	13 A 24	GREZZO	SQUADRETTA PRESSOFUSA A SCATTO ANGOLAZIONE VARIABILE	ALLUMINIO	PEZZI 20
	13 C 15	GREZZO	KIT DI COLLEGAMENTO PER APERTURE ESTERNE mm 45 mm 52	ALLUMINIO	PEZZI 20
	13 D 22	NERO	COPPIA TAPPI CHIUDI TUBOLARITA' PER Pr 19663	NYLON	COPPIA 50
	13 D 31	NERO	TAPPI PER GIUNZIONE CENTRALE PER DOPPIA BATTUTA CON PROFILATO DI RIPORTO Pr 19663	NYLON	COPPIA 30
	13 D 44	NERO	COPPIA TAPPI CHIUDI TUBOLARITA' PER Pr 24457	NYLON	COPPIA 30

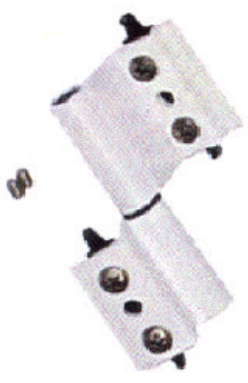

ACCESSORI	CODICE	COLORE	DESCRIZIONE	MATER.	CONFEZ.
	13 D 100	NERO	TAPPO CHIUDI TUBOLARITA' PER Pr 27329	NYLON	COPPIA 25
	13 E 03	GRIGIO	ESPANSORE DI REGOLAZIONE E FISSAGGIO PER Pr 19714-16973-26137	NYLON	PEZZI 1000
	15 A 42	GREZZO	SUADRETTA DI ALLINEAMENTO UNIVERSALE CON ECCENTRICI	ALLUMINIO	PEZZI 250
	30 B 11	GREZZO	CERNIERA COLLO LUNGO PER SORMONTO (IMPACCHETTAMENTO A 2 ANTE)	ALLUMINIO	PEZZI 50
	30 D 85	NERO	TAPPI CHIUDI TUBOLARITA' PER Pr 27394	NYLON	COPPIE 50
	30 D 200	NERO	TAPPI CHIUDI TUBOLARITA' PER Pr 37635 * In allestimento.	NYLON	COPPIE 50



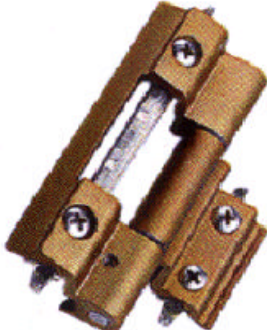
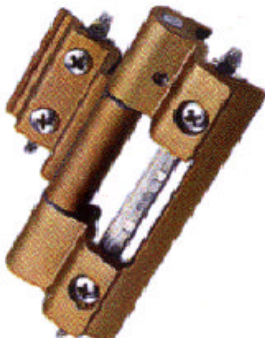



ACCESSORI	CODICE	COLORE	DESCRIZIONE	MATER.	CONFEZ.
	64 B 30	GREZZO OX.NAT. OX.BRZ. ELETTR. RAL1013 RAL9005 RAL9010 RAL6005 RAL8017	CERNIERA PER TERZA ANTA A COLLO LUNGO	ALLUMINIO	PEZZI 50
	64 B 80	GREZZO OX.NAT. OX.BRZ. ELETTR. RAL1013 RAL9005 RAL9010 RAL6005 RAL8017	CERNIERA REVERSIBILE "PRETTY"	ALLUMINIO	PEZZI 50
	64 B 90	GREZZO OX.NAT. OX.BRZ. ELETTR. RAL1013 RAL9005 RAL9010 RAL6005 RAL8017	CERNIERA REVERSIBILE "PRETTY" PER TERZA ANTA	ALLUMINIO	PEZZI 50
	64 B 130	GREZZO OX.NAT. OX.BRZ. ELETTR. RAL1013 RAL9005 RAL9010 RAL6005 RAL8017	CERNIERA PER TERZA ANTA A COLLO LUNGO A 3 ALI	ALLUMINIO	PEZZI 50

ACCESSORI	CODICE	COLORE	DESCRIZIONE	MATER.	CONFEZ.
	64 D 70	NERO	TERMINALE ASTA CON PUNTALE DECENTRATO DX	ZAMA	PEZZI 50
	64 D 71	NERO	TERMINALE ASTA CON PUNTALE DECENTRATO SX	ZAMA	PEZZI 50
	64 D 72	NERO	PALETTO CON TERMINALE ASTA E PUNTALE DECENTRATO DX	ZAMA NYLON	PEZZI 50
	64 D 73	NERO	PALETTO CON TERMINALE ASTA E PUNTALE DECENTRATO SX	ZAMA NYLON	PEZZI 50
	71 D 20	NERO	INCONTRO PER ASTA E TERZA CHIUSURA	NYLON	PEZZI 250
	71 D 21	NERO	TERMINALE PER ASTA DI CHIUSURA	NYLON	PEZZI 50
	71 D 22	NERO	COPPIA CATENACCI PER SCANALATURA ESTERNA	ALLUMINIO	COPPIA 25
	71 D 23	NERO	INCONTRO DOPPIO PER ASTA DI CHIUSURA	ZAMA	PEZZI 50

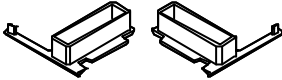
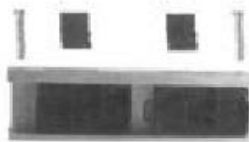

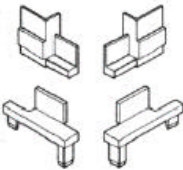
ACCESSORI	CODICE	COLORE	DESCRIZIONE	MATER.	CONFEZ.
	71 B 60	GREZZO OX.NAT. OX.BRZ. ELETTR. RAL1013 RAL9005 RAL9010 RAL6005 RAL8017	CERNIERA A CONTRASTO DUE ALI	ALLUMINIO	PEZZI 50
	71 B 61	GREZZO OX.NAT. OX.BRZ. ELETTR. RAL1013 RAL9005 RAL9010 RAL6005 RAL8017	CERNIERA A CONTRASTO DUE ALI TERZA ANTA	ALLUMINIO	PEZZI 50
	71 B 62	GREZZO OX.NAT. OX.BRZ. ELETTR. RAL1013 RAL9005 RAL9010 RAL6005 RAL8017	CERNIERA A CONTRASTO TRE ALI	ALLUMINIO	PEZZI 50
	71 B 63	GREZZO OX.NAT. OX.BRZ. ELETTR. RAL1013 RAL9005 RAL9010 RAL6005 RAL8017	CERNIERA A CONTRASTO A TRE ALI TERZA ANTA	ALLUMINIO	PEZZI 50

ACCESSORI	CODICE	COLORE	DESCRIZIONE	MATER.	CONFEZ.
	71 B 84	GREZZO OX.NAT. OX.BRZ. ELETTR. RAL1013 RAL9005 RAL9010 RAL6005 RAL8017	CERNIERA A PETTINE CON GRANO	ALLUMINIO	PEZZI 50
	71 B 85	GREZZO OX.NAT. OX.BRZ. ELETTR. RAL1013 RAL9005 RAL9010 RAL6005 RAL8017	CERNIERA A PETTINE TERZA ANTA	ALLUMINIO	PEZZI 50
	91 E 01	GREZZO	ESPANSORE PER Pr 34636 E Pr 34637	ZAMA	PEZZI 100

SEZIONE	CODICE	DESCRIZIONE	BOBINE m	SCATOLA m
	90 G 26	GUARNIZIONE PER BATTUTA INTERNA MATERIALE: ELAPRENE COLORE: NERO	400	800
	STG 29	GUARNIZIONE PER DOPPIA BATTUTA MATERIALE: EPDM COLORE: NERO	DOPPIA 400	400

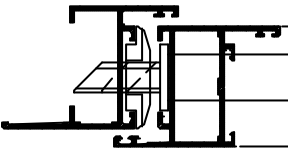
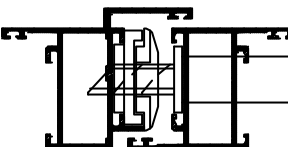

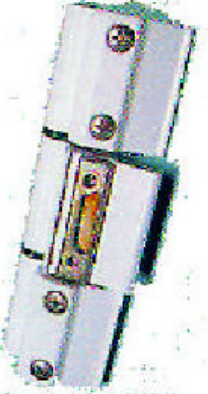
ACCESSORI	CODICE	COLORE	DESCRIZIONE	MATER.	CONFEZ.
	30 D 17	NERO	TAPPI CHIUDI TUBOLARITA' PER Pr 21688	NYLON	COPPIA 50
	40 C 02	GREZZO	KIT DI COLLEGAMENTO E FISSAGGIO CREMONESE APERTURA ESTERNA	NYLON ALLUMINIO	PEZZI 20
	40 C 03	GREZZO	PERNO DI COLLEGAMENTO	ACCIAIO	PEZZI 200
	40 D 07	NERO	TAPPI DI CHIUDIBATTUTA E CONTINUITA'	NYLON	COPPIA 200
	40 D 08	NERO	COPPIA TAPPI NODO CENTRALE CON PROFILATO DI RIPORTO Pr 21688	NYLON	COPPIA 50
	40 D 18	NERO	COPPIA TAPPI NODO CENTRALE CON PROFILATO DI RIPORTO ARROTONDATO Pr 23339	NYLON	COPPIA 50
	40 D 40	NERO	SELLA REVERSIBILE PER Pr 19741 PER OVALINA 50mm - Pr 10763	NYLON	PEZZI 500
	40 E 03	GRIGIO	ESPANSORE DI REGOLAZIONE E FISSAGGIO	NYLON	PEZZI 100

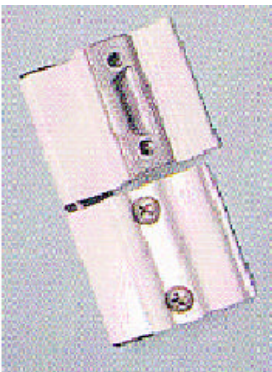



ACCESSORI	CODICE	COLORE	DESCRIZIONE	MATER.	CONFEZ.
<p>NODO LATERALE</p>  <p>NODO CENTRALE</p> 	40 S 01	NERO	INCONTRO SERRATURA PER 1 ANTA PIU' SPESSORE INCONTRO PER 2 ANTE	NYLON	PEZZI 10





ACCESSORI	CODICE	COLORE	DESCRIZIONE	MATER.	CONFEZ.
	40 B 23	GREZZO OX.NAT. OX.BRZ. ELETTR. RAL1013 RAL6005 RAL8017 RAL9005 RAL9010	CERNIERA REVERSIBILE COLLO LUNGO	ALLUMINIO	PEZZI 50
	40 B 120	GREZZO OX.NAT. OX.BRZ. ELETTR. RAL1013 RAL6005 RAL8017 RAL9005 RAL9010	CERNIERA REVERSIBILE A 3 ALI	ALLUMINIO	PEZZI 50
	64 B 10	GREZZO OX.NAT. OX.BRZ. ELETTR. RAL1013 RAL6005 RAL8017 RAL9005 RAL9010	CERNIERA REVERSIBILE CON PIASTRINA DI AGGANCIO PER APERTURE ESTERNE	ALLUMINIO	PEZZI 50
	64 B 20	GREZZO OX.NAT. OX.BRZ. ELETTR. RAL1013 RAL9005 RAL9010 RAL6005 RAL8017	CERNIERA "PRETTY" REVERSIBILE CON PIASTRINA DI AGGANCIO PER 3*ANTA (ABBINAMENTO DOMAL 40)	ALLUMINIO	PEZZI 50

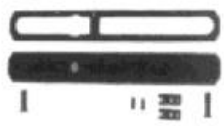





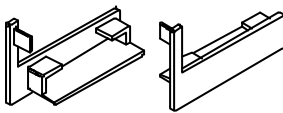



ACCESSORI	CODICE	COLORE	DESCRIZIONE	MATER.	CONFEZ.
	64 B 40	GREZZO OX.NAT. OX.BRZ. ELETTR. RAL1013 RAL6005 RAL8017 RAL9005 RAL9010	CERNIERA "PRETTY" REVERSIBILE PER DOMAL COMPLANARE (ABBINAMENTO DOMAL 40)	ALLUMINIO	PEZZI 50
	64 B 70	GREZZO OX.NAT. OX.BRZ. ELETTR. RAL1013 RAL6005 RAL8017 RAL9005 RAL9010	CERNIERA REVERSIBILE PER TERZA ANTA	ALLUMINIO	PEZZI 50
	64 B 123	GREZZO OX.NAT. OX.BRZ. ELETTR. RAL1013 RAL6005 RAL8017 RAL9005 RAL9010	CERNIERA REVERSIBILE COLLO LUNGO A 3 ALI	ALLUMINIO	PEZZI 50
	64 B 170	GREZZO OX.NAT. OX.BRZ. ELETTR. RAL1013 RAL6005 RAL8017 RAL9005 RAL9010	CERNIERA REVERSIBILE COLLO LUNGO A 3 ALI PER TERZA ANTA	ALLUMINIO	PEZZI 50



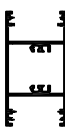





ACCESSORI	CODICE	COLORE	DESCRIZIONE	MATER.	CONFEZ.
	64 D 2L	NERO	TERMINALE PER ASTE ESTERNE	NYLON	COPPIA 50
	64 D 3L	NERO	INCONTRO DOPPIO DI CHIUSURA	ZAMA	PEZZI 50
	64 D 4L	NERO	INCONTRO TERZA CHIUSURA	ZAMA	PEZZI 50
	64 D 6L	NERO	PALETTO PER SECONDA ANTA	NYLON	PEZZI 50





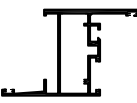
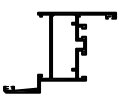

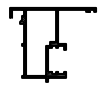

SEZIONE	CODICE	DESCRIZIONE	BOBINE m	SCATOLA m
	90 G 31	GUARNIZIONE DI BATTUTA MATERIALE: EPDM COLORE: NERO	DOPPIA 400	DOPPIA 400
	90 G 91	GUARNIZIONE DI BATTUTA A BASE RIGIDA MATERIALE: EPDM-PVC COLORE: NERO	300	600

ACCESSORI	CODICE	COLORE	DESCRIZIONE	MATER.	CONFEZ.
	13 D 66	NERO	CATENACCIO "TOTEM"	NYLON	PEZZI 10
	30 D 30	NERO	COPPIA TAPPI LATERALI PER CHIUSURA CARTELLA SUPERIORE	NYLON	COPPIA 8
	30 R 10	GREZZO	FERMO PER ARRESTO ANTA SCORREVOLE	ACCIAIO	PEZZI 50
	30 R 11	GREZZO	GUIDA A RULLO INFERIORE IN FIBRA	ACCIAIO	PEZZI 50
	30 R 12	GREZZO	CARRELLO CON CUSCINETTI PER ANTA SCORREVOLE (PORTATA Kg 50)	ACCIAIO	PEZZI 20
	11 P 02	NERO	PLACCA CON FORO ϕ 9 (PER CHIAVE A CROCE E POMOLO) Cod. 11 P 05	ALLUMINIO	PEZZI 5
	30 M 01	ELETTRO RAL9005	MANIGLIA DI CHIUSURA SUNNY SCORREVOLE	ALLUMINIO	PEZZI 1
	30 M 100	ELETTRO. RAL9005	MANIGLIA DI CHIUSURA CON BLOCCO SUNNY SCORREVOLE	ALLUMINIO	PEZZI 1

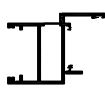
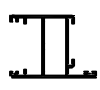

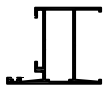
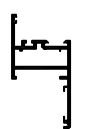

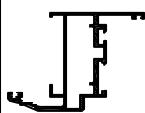

ACCESSORI	CODICE	COLORE	DESCRIZIONE	MATER.	CONFEZ.
	11 P 05	NERO	POMOLO PER QUADRO DA 8 mm	NYLON	PEZZI 5
	11 S 02	GREZZO	SERRATURA A GANCIO CON CHIAVE A CROCE	ACCIAIO	PEZZI 1
 TAPPO SX. E DX.	GE 005	NERO	TAPPO CHIUSURA TUBOLARITA' PER Pr 16075	NYLON	COPPIE 100
	90 S 52	NERO	SPAZZOLINO DI TENUTA CENTRALE ANTA 7x7 mm	POLIPROP.	BOBINE 225 mt.
	90 S 62	NERO	SPAZZOLINO DI TENUTA PERIMETRALE ANTA E TELAIO 7x11 mm	POLIPROP.	BOBINE 200 mt.

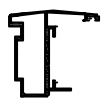
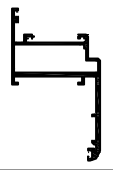
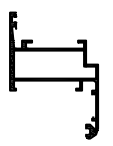
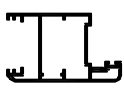
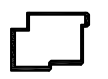
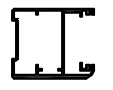
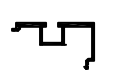
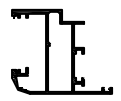
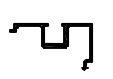

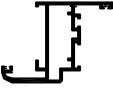
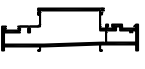



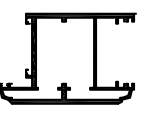
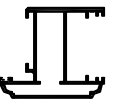

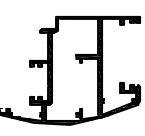
SEZIONE	CODICE	PESO Kg/m.	SUP. IN VISTA mm.	PAG.	SERIE	DESCRIZIONE
	Pr 10763	0,347	111	B 04	VARIE	PROFILATO OVALINA mm. 50
	Pr 11048	0,144	14	B 12	PG	PROFILATO ASTA DI CHIUSURA
	Pr 13199	0,448	141	B 04	VARIE	PROFILATO OVALINA mm. 65
	Pr 16012	1,509	221	B 02	VARIE	PROFILATO FASCIA/ZOCCOLO mm. 100
	Pr 16013	1,207	165	B 02	VARIE	PROFILATO FASCIA/ZOCCOLO mm. 75
	Pr 16038	0,537	81	B 17	SCORREVOLE	PROFILATO BATTUTA "GENOVESE"
	Pr 16039	0,432	47	B 17	SCORREVOLE	PROFILATO DI RIPORTO "GENOVESE"
	Pr 16060	0,262	25	B 04	VARIE	PROFILATO PORTA OVALINA
	Pr 16065	0,996	104	B 16	SCORREVOLE	PROFILATO ANTA SCORREVOLE - "GENOVESE"
	Pr 16073	0,996	168	B 16	SCORREVOLE	PROFILATO CARTELLA PER GUIDA SUP. SCORR.

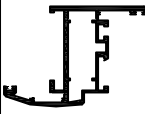
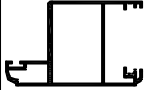

SEZIONE	CODICE	PESO Kg/m.	SUP. IN VISTA mm.	PAG.	SERIE	DESCRIZIONE
	Pr 16074	0,904	=	B 16	SCORREVOLE	PROFILATO GUIDA SUPERIORE SCORREVOLE
	Pr 16075	0,788	152	B 16	SCORREVOLE	PROFILATO GUIDA INFERIORE SCORREVOLE
	Pr 16076	0,329	61	B 16	SCORREVOLE	PROFILATO GUIDA INFERIORE SCORREVOLE
	Pr 16077	0,270	57	B 17	SCORREVOLE	PROFILATO DI RIPORTO-TENUTA SCORREVOLE
	Pr 16950	0,883	109	B 06	PG	PROFILATO TELAIO mm 45
	Pr 16973	0,924	119	B 06	PG	PROFILATO TELAIO mm 52
	Pr 19637	0,211	37	B 17	SCORREVOLE	PROFILATO BATTUTA DI RIPORTO
	Pr 19646	0.201	36	B 04	VARIE	PROFILATO DI FINITURA (SOTTOZOCICOLO)
	Pr 19647	0,311	21	B 04	VARIE	PROFILATO PORTA LAMELLA DI COMPENSAZIONE
	Pr 19663	0,826	82	B 10	PG	PROFILATO DI RIPORTO DOPPIA BATTUTA (ABB. Pr 24457 - 27394)



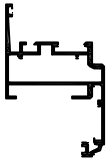
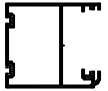
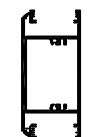
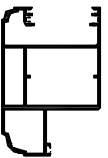
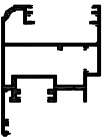
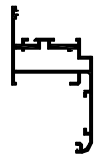

SEZIONE	CODICE	PESO Kg/m.	SUP. IN VISTA mm.	PAG.	SERIE	DESCRIZIONE
	Pr 19714	0,956	109	B 06	PG	PROFILATO TELAIO mm 52
	Pr 19715	0,853	80	B 06	PG	PROFILATO TELAIO mm 52
	Pr 19723	0,853	137	B 14	D. 40	PROFILATO ANTA
	Pr 19724	0,748	108	B 14	D. 40	PROFILATO ANTA
	Pr 19730	0,165	23	B 15	D. 40	PROFILATO ASTA DI CHIUSURA
	Pr 19741	0,637	92	B 15	D. 40	PROFILATO ANTA
	Pr 21676	0,960	127	B 07	PG	PROFILATO TELAIO
	Pr 21688	0,662	74	B 14	D. 40	PROFILATO BATTUTA RIPORTATA (o STULP) (ABB. DOMAL 40)
	Pr 23237	0,991	117	B 06	PG	PROFILATO TELAIO SAGOMATO mm. 52
	Pr 23283	1,113	257	B 07	PG	PROFILATO TELAIO mm. 52

SEZIONE	CODICE	PESO Kg/m.	SUP. IN VISTA mm.	PAG.	SERIE	DESCRIZIONE
	Pr 23328	0,902	138	B 13	D. 40	PROFILATO TELAIO (ABB. DOMAL 40)
	Pr 23339	0,680	71	B 14	D. 40	PROFILATO BATTUTA DI RIPORTO
	Pr 23341	0,894	119	B 13	D. 40	PROFILATO TELAIO "Z" COMPLANARE BATTUTA DA 40 mm.
	Pr 23342	0,805	104	B 13	D. 40	PROFILATO TELAIO "Z" COMPLANARE BATTUTA DA 25 mm.
	Pr 24451	1,208	80	B 05	STORICA	PROFILATO ANTA "STORICA"
	Pr 24452	0,578	101	B 05	STORICA	PROFILATO DI RIPORTO "STORICA"
	Pr 24455	0,983	190	B 05	STORICA	PROFILATO ANTA "STORICA" SENZA BATTUTA (ABBINAMENTO Pr 24451)
	Pr 24456	0,378	54	B 12	PG	PROFILATO PORTA OVALINA (ABBINAMENTO PG)
	Pr 24457	1,040	130	B 10	PG	PROFILATO ANTA mm 52
	Pr 24458	0,378	54	B 12	PG	PROFILATO PORTA OVALINA (ABBINAMENTO PG)

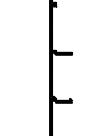
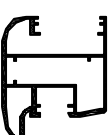
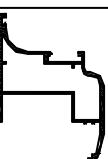
SEZIONE	CODICE	PESO Kg/m.	SUP. IN VISTA mm.	PAG.	SERIE	DESCRIZIONE
	Pr 26137	1,018	119	B 06	PG	PROFILATO TELAIO (ABBINAMENTO PG)
	Pr 26144	2,060	136	B 07	PG	PROFILATO TELAIO
	Pr 26187	0,327	44	B 15	D. 40	PROFILATO PORTA OVALINA (ABB. DOMAL 40)
	Pr 26200	0,684	96	B 13	D. 40	PROFILATO TELAIO (ABB. DOMAL 40)
	Pr 26210	1,785	272	B 02	VARIE	PROFILATO FASCIA/ZOCCOLO mm 130
	Pr 26217	1,040	129	B 10	PG	PROFILATO ANTA SAGOMATA
	Pr 26235	1,188	148	B 14	D. 40	PROFILATO ANTA MAGGIORATA
	Pr 26236	0,994	116	B 14	D. 40	PROFILATO ANTA
	Pr 26237	0,208	42	B 04	VARIE	PROFILATO DI FINITURA CHIUDI TUBOLARITA'
	Pr 27329	1,323	150	B 10	PG	PROFILATO ANTA

SEZIONE	CODICE	PESO Kg/m.	SUP. IN VISTA mm.	PAG.	SERIE	DESCRIZIONE
	Pr 27330	1,018	118	B 08	PG	PROFILATO TELAIO
	Pr 27362	0,967	189	B 05	STORICA	PROFILATO ANTA STORICA
	Pr 27366	0,490	157	B 01	VARIE	PROFILATO LAMELLA PIANA 70 mm.
	Pr 27367	0,499	160	B 01	VARIE	PROFILATO LAMELLA "GOCCIA" 70 mm.
	Pr 27368	0,494	158	B 01	VARIE	PROFILATO LAMELLA "RUSTICA" 70 mm.
	Pr 27369	0,375	108	B 01	VARIE	PROFILATO COMPENSATORE
	Pr 27370	0,381	47	B 01	VARIE	PROFILATO COMPENSATORE
	Pr 27372	0,405	85	B 04	VARIE	PROFILATO COMPENSATORE
	Pr 27374	1,492	293	B 03	VARIE	PROFILATO ROMPIRATTA P60
	Pr 27375	1,031	146	B 15	D. 40	PROFILATO ANTA mm. 47

SEZIONE	CODICE	PESO Kg/m.	SUP. IN VISTA mm.	PAG.	SERIE	DESCRIZIONE
	Pr 27376	1,085	128	B 08	PG	PROFILATO TELAIO "Z" COMPLANARE BATTUTA DA 30 mm.
	Pr 27378	0,813	145	B 05	STORICA	PROFILATO ANTA STORICA SENZA BATTUTA (ABBINAMENTO Pr 27362)
	Pr 27379	1,588	222	B 03	STORICA	PROFILATO FASCIA/ZOCCOLO mm. 100 (ABBINAMENTO Pr 27380 - 27394)
	Pr 27380	1,380	168	B 05	STORICA	PROFILATO ANTA "STORICA" mm. 52
	Pr 27394	1,153	142	B 10	PG	PROFILATO ANTA mm. 52
	Pr 27583	1,142	141	B 08	PG	PROFILATO TELAIO "Z" COMPLANARE BATTUTA DA 45 mm.
	Pr 31931	0,300	67	B 18	FRANGISOLE	PROFILATO ALETTA FRANGISOLE
	Pr 31932	1,104	220	B 18	FRANGISOLE	PROFILATO BASE MODULARE FRANGISOLE
	Pr 34635	1,355	146	B 11	PG	PROFILATO ANTA
	Pr 34636	1,131	138	B 09	PG	PROFILATO TELAIO "Z"

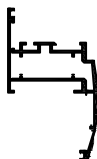
SEZIONE	CODICE	PESO Kg/m.	SUP. IN VISTA mm.	PAG.	SERIE	DESCRIZIONE
	Pr 34637	0,613	7,5	B 09	PG	PROFILATO ATTACCO A MURO
	Pr 34640	1,933	472	B 19	FRANGISOLE	PALA FRANGISOLE
	Pr 50013	0,240	111	B 04	VARIE	PROFILATO OVALINA mm. 50 (ALLEGGERITA)
	Pr 60009	0,378	19	B 12	PG	PROFILATO SOTTOZOCOLO (ABBINAMENTO Pr 24457 - 27394)
	Pr 60058	1,096	133	B 09	PG	PROFILATO TELAIO STONDATO BATTUTA DA 40 mm.

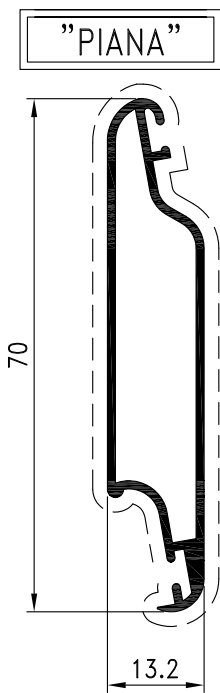

Pr. 27366 kg/m. 0.490
sup. in vista mm. 157

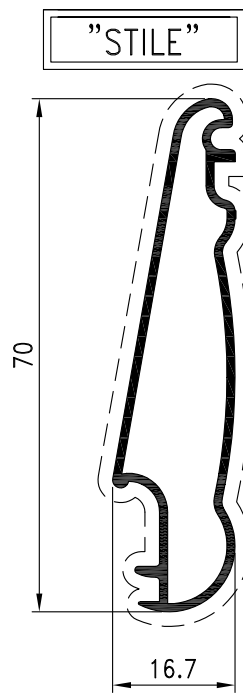

3260063 kg/m. 0.501
sup. in vista mm. 177

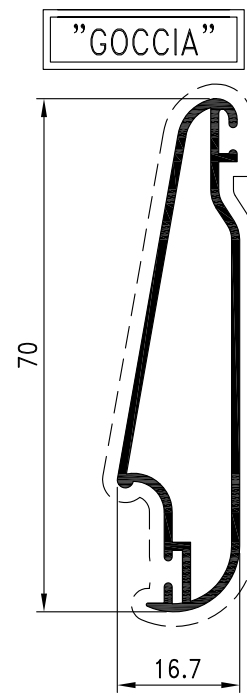

Pr. 27367 kg/m. 0.499
sup. in vista mm. 160

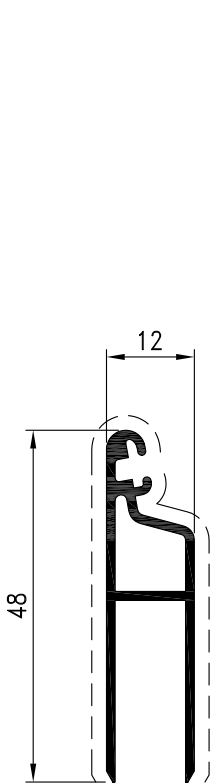

Pr. 27369 kg/m. 0.375
sup. in vista mm. 108

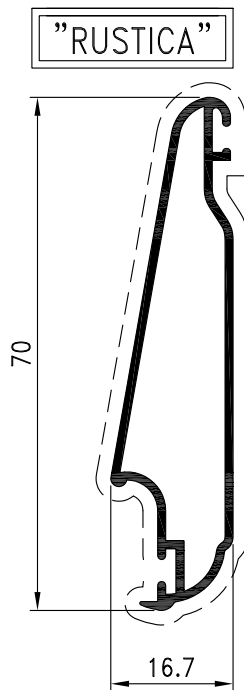

Pr. 27368 kg/m. 0.494
sup. in vista mm. 158

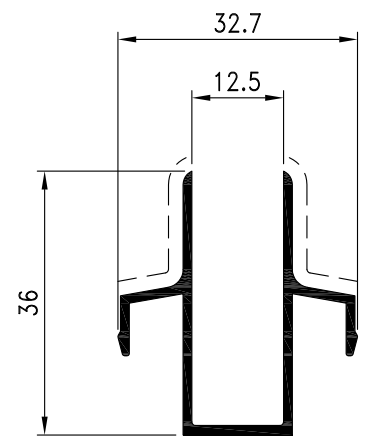

Pr. 27370 kg/m. 0.381
sup. in vista mm. 47

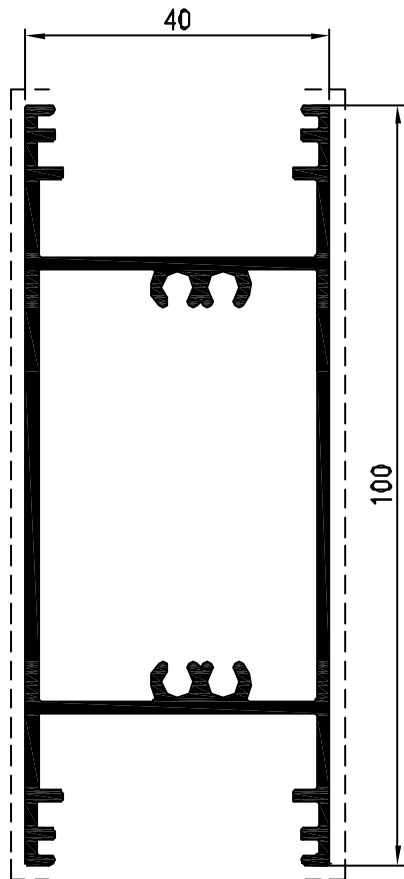

Pr. 16012 kg/m. 1.509
 sup. in vista mm. 221

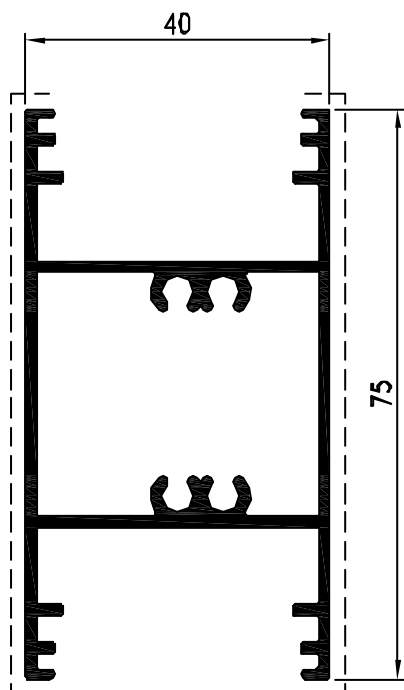

Pr. 16013 kg/m. 1.207
 sup. in vista mm. 165

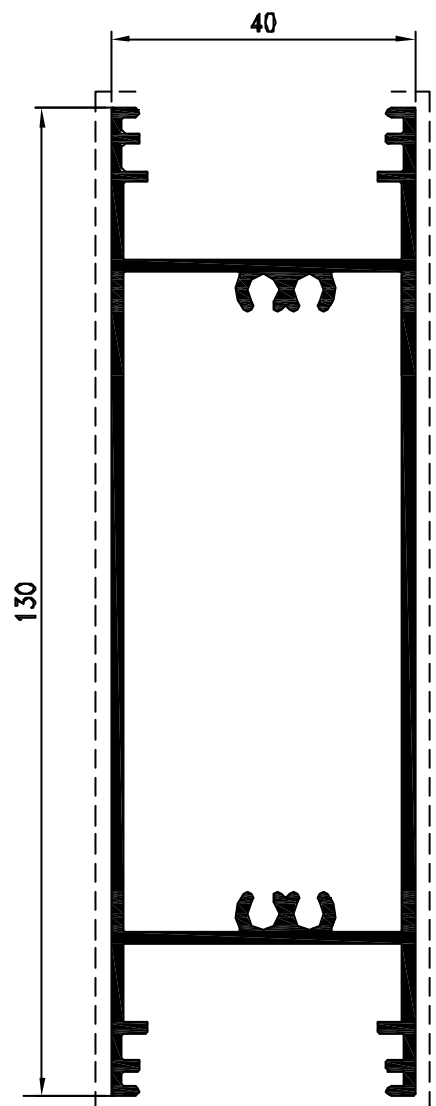

Pr. 26210 kg/m. 1.785
 sup. in vista mm. 272

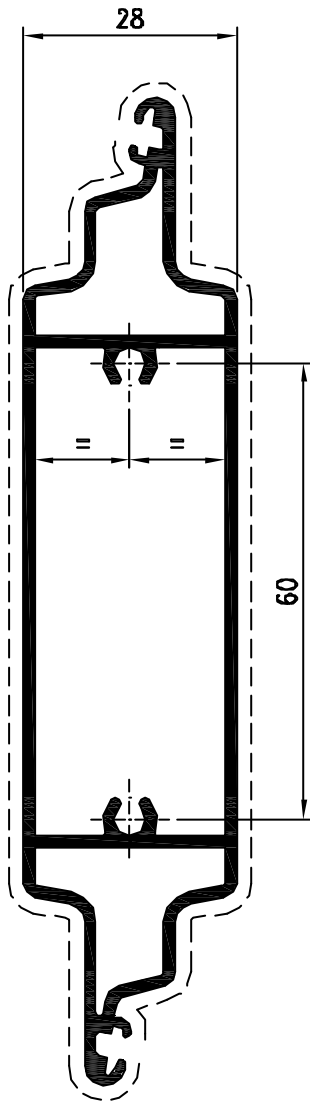

Pr. 27374 kg/m. 1.492
sup. in vista mm. 293

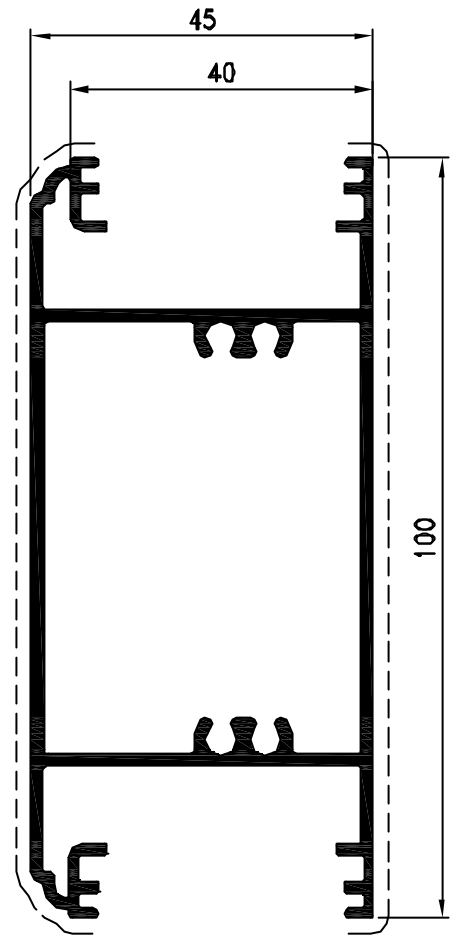

Pr. 27379 kg/m. 1.588
sup. in vista mm. 222

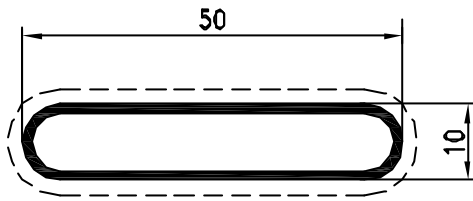

Pr. 10763 kg/m. 0.347
sup. in vista mm. 111

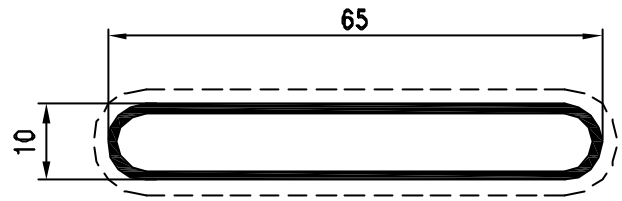

Pr. 13199 kg/m. 0.448
sup. in vista mm. 141

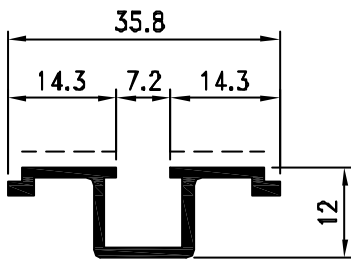

Pr. 16060 kg/m. 0.262
sup. in vista mm. 25

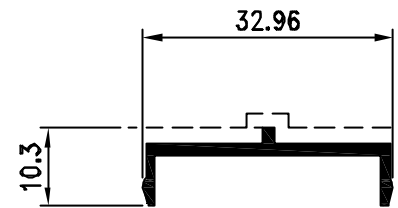

Pr. 19646 kg/m. 0.201
sup. in vista mm. 36

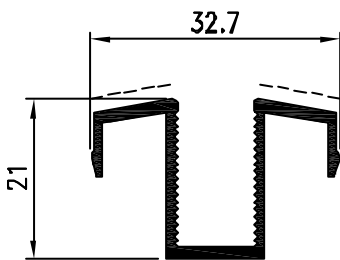

Pr. 19647 kg/m. 0.311
sup. in vista mm. 21

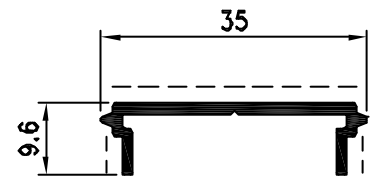

Pr. 26237 kg/m. 0.208
sup. in vista mm. 42

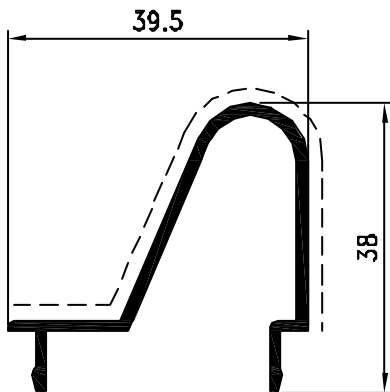

Pr. 27372 kg/m. 0.405
sup. in vista mm. 85

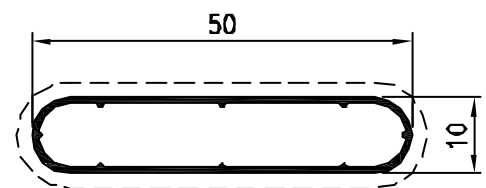

Pr. 50013 kg/m. 0.240
sup. in vista mm. 111

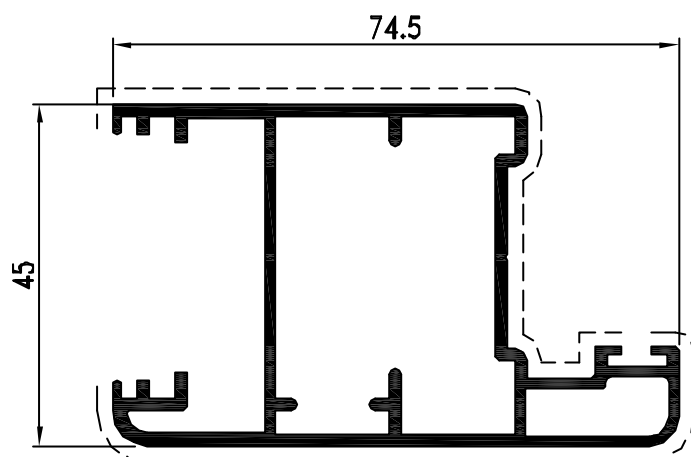

Pr. 24451 kg/m. 1.208
sup. in vista mm. 210

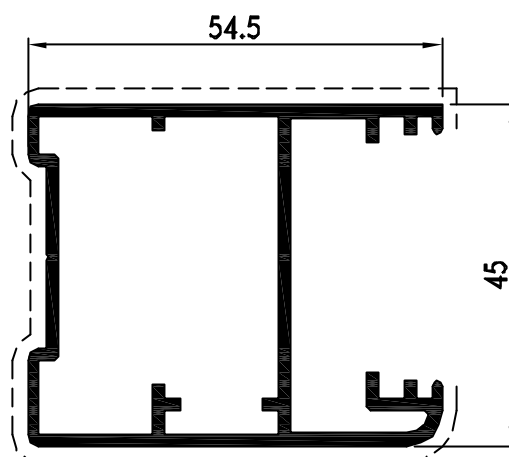

Pr. 24455 kg/m. 0.983
sup. in vista mm. 190

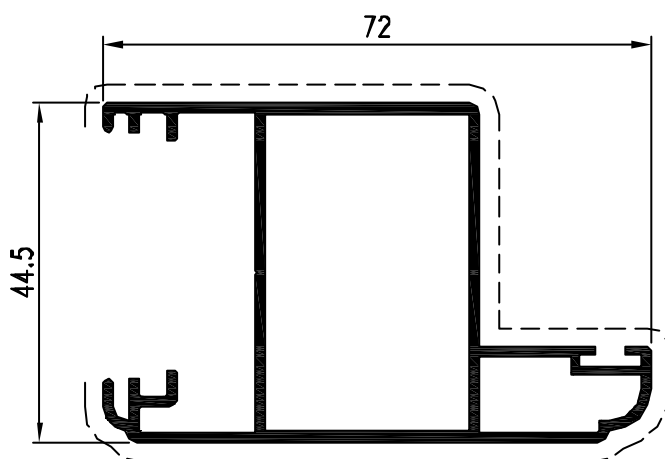

Pr. 27362 kg/m. 0.967
sup. in vista mm. 189

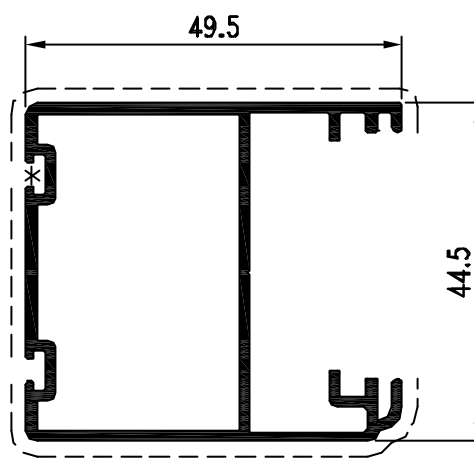

Pr. 27378 kg/m. 0.813
sup. in vista mm. 145

*usare spazzolini con base 5mm

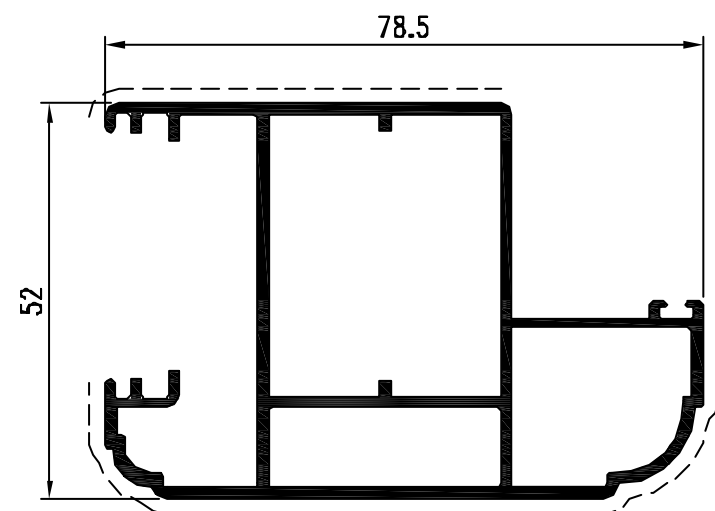

Pr. 27380 kg/m. 1.380
sup. in vista mm. 168

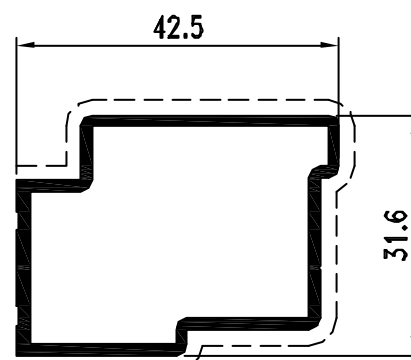

Pr. 24452 kg/m. 0.578
sup. in vista mm. 101

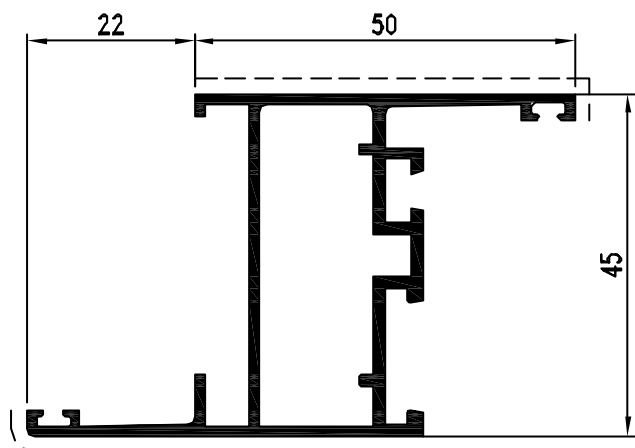

Pr. 16950 kg/m. 0.883
sup. in vista mm. 109

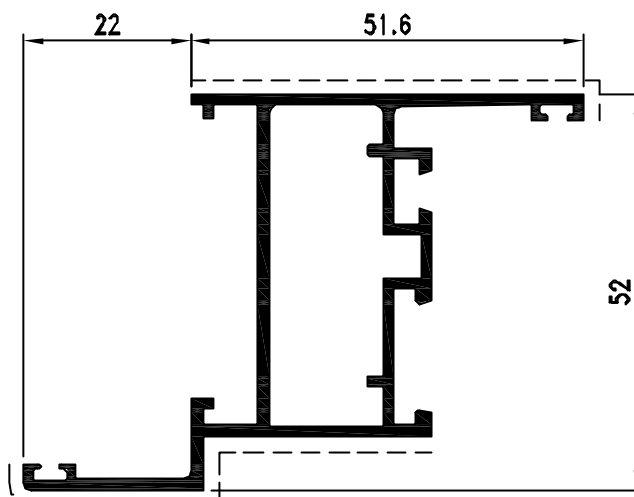

Pr. 16973 kg/m. 0.924
sup. in vista mm. 119

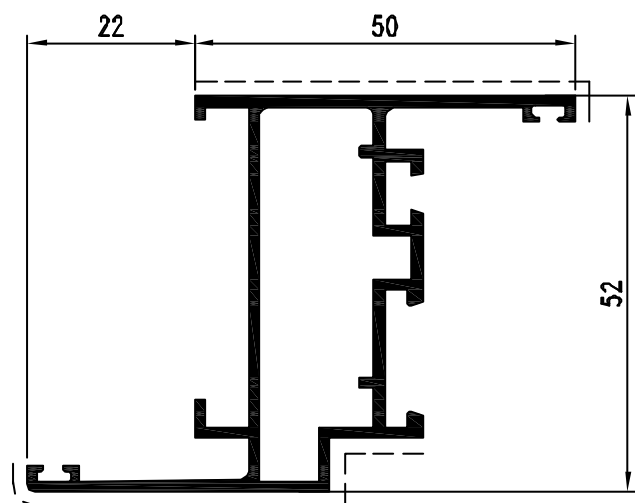

Pr. 19714 kg/m. 0.956
sup. in vista mm. 109

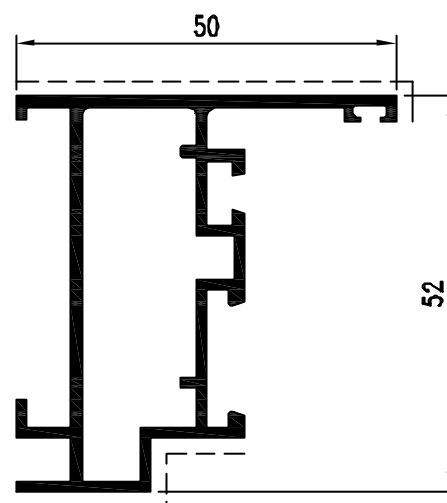

Pr. 19715 kg/m. 0.853
sup. in vista mm. 80

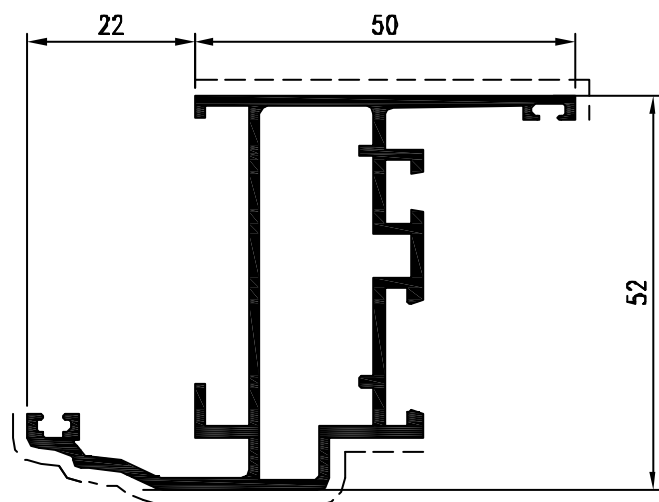

Pr. 23237 kg/m. 0.991
sup. in vista mm. 117

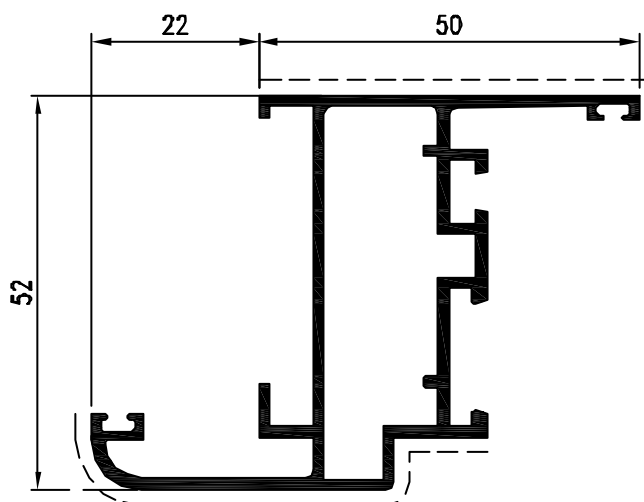

Pr. 26137 kg/m. 1.018
sup. in vista mm. 119

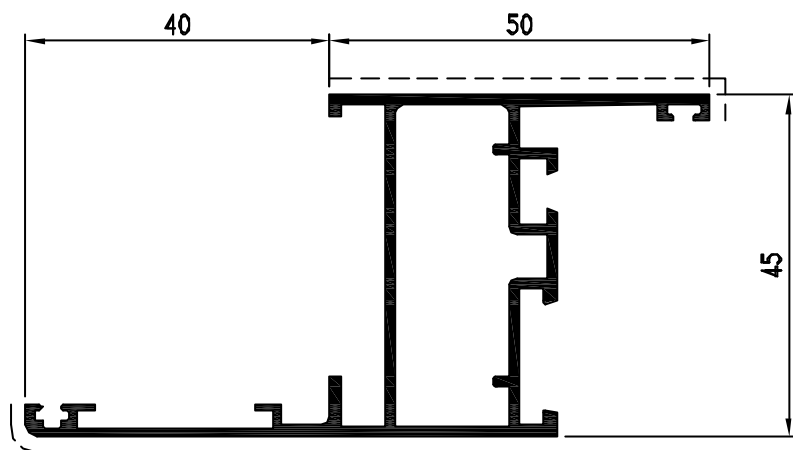

Pr. 21676 kg/m. 0.960
sup. in vista mm. 127

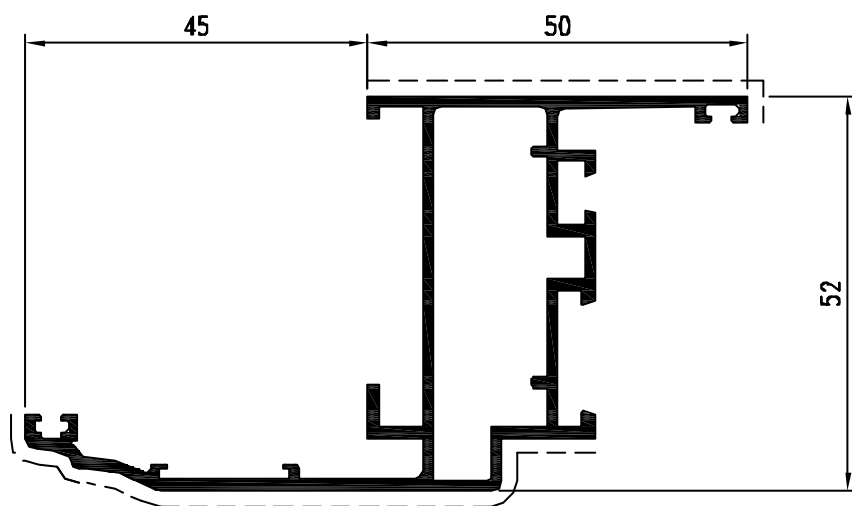

Pr. 23283 kg/m. 1.113
sup. in vista mm. 257

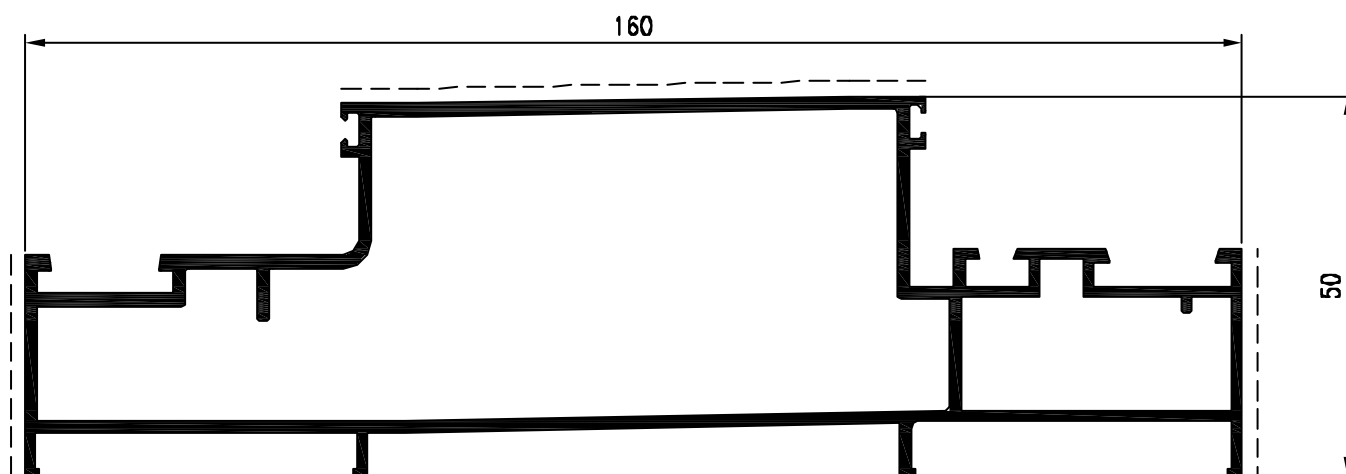

Pr. 26144 kg/m. 2.060
sup. in vista mm. 136

GELOSIA PORTA 1 ANTA
 Abbinamento
 DOMAL STOPPER PG

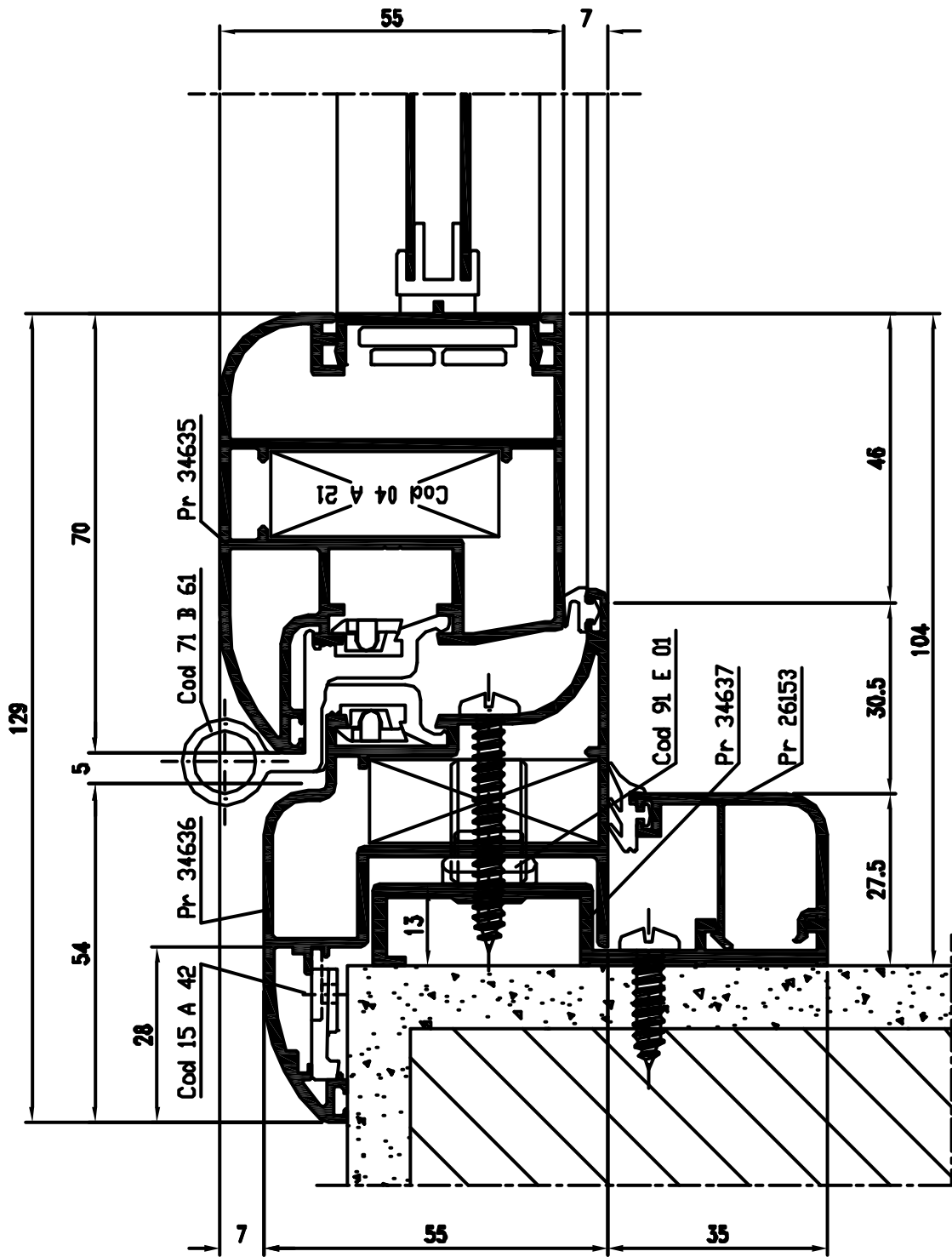
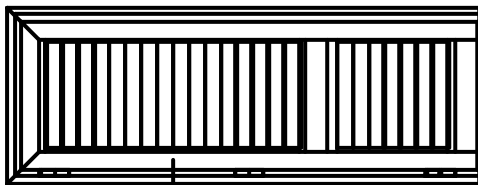

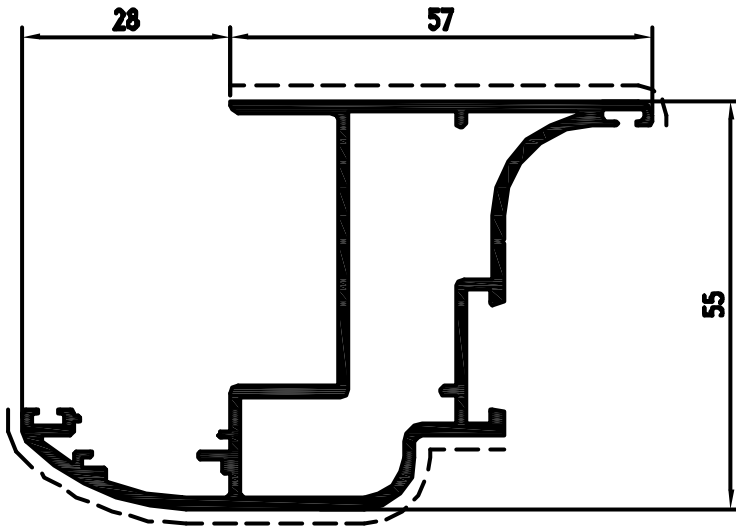

Pr. 34636 kg/m. 1.131
sup. in vista mm. 138

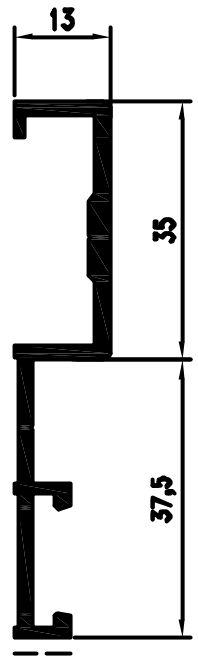

Pr. 34637 kg/m. 0.613
sup. in vista mm. 7.5

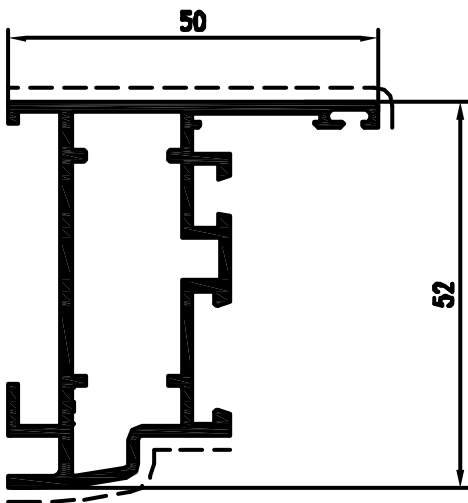

Pr. 60048 kg/m. 0.867
sup. in vista mm. 88

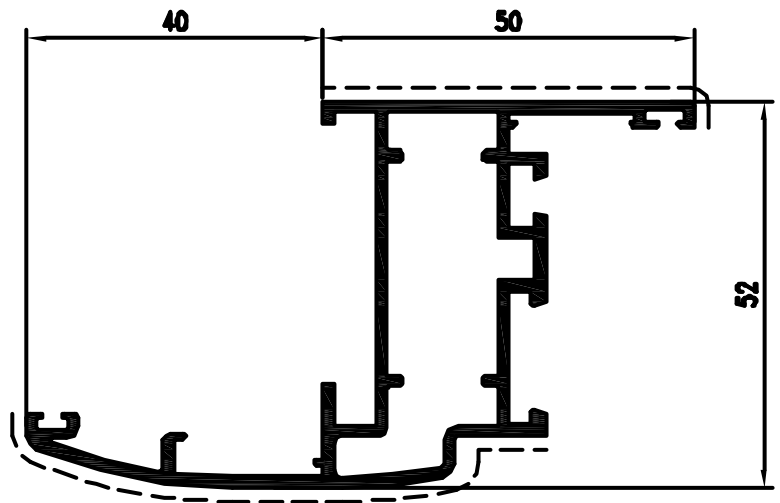

Pr. 60058 kg/m. 1.098
sup. in vista mm. 133

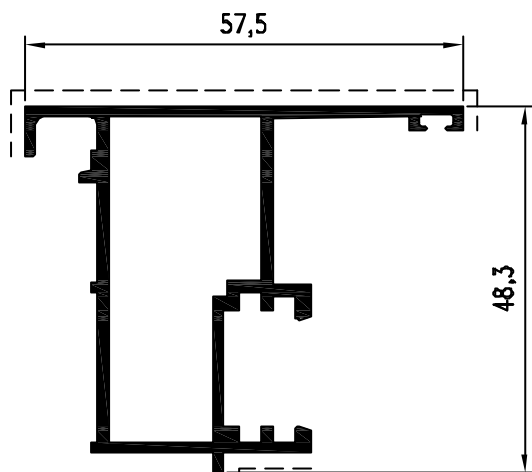

Pr. 19663 kg/m. 0.826
sup. in vista mm. 82

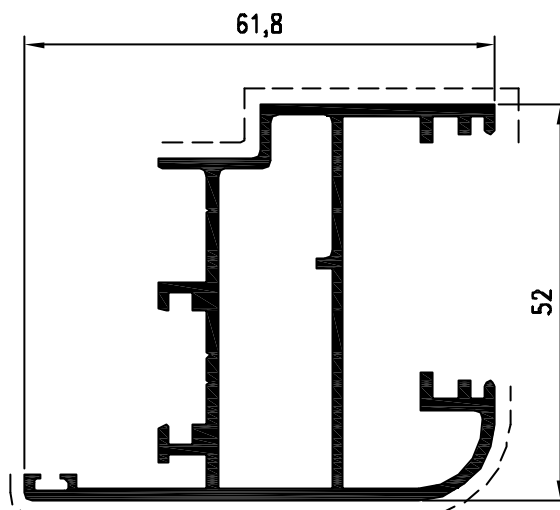

Pr. 24457 kg/m. 1.040
sup. in vista mm. 130

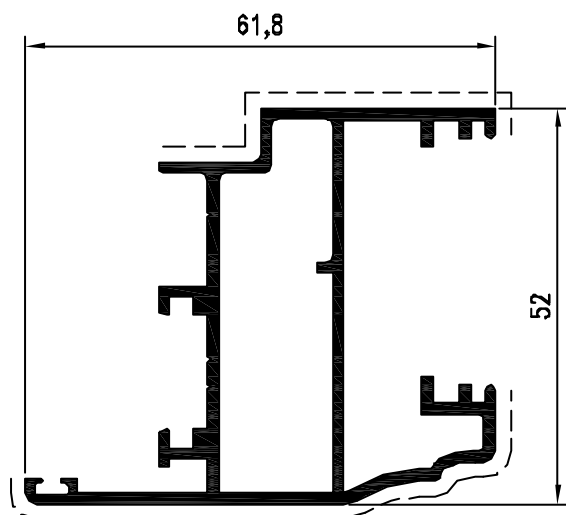

Pr 26217 Kg/m 1.040
sup. in vista mm. 129

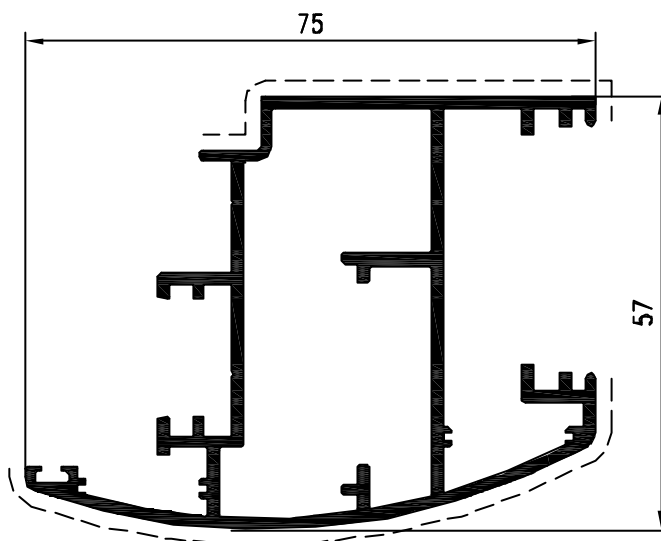

Pr 27329 Kg/m 1.323
sup. in vista mm. 150

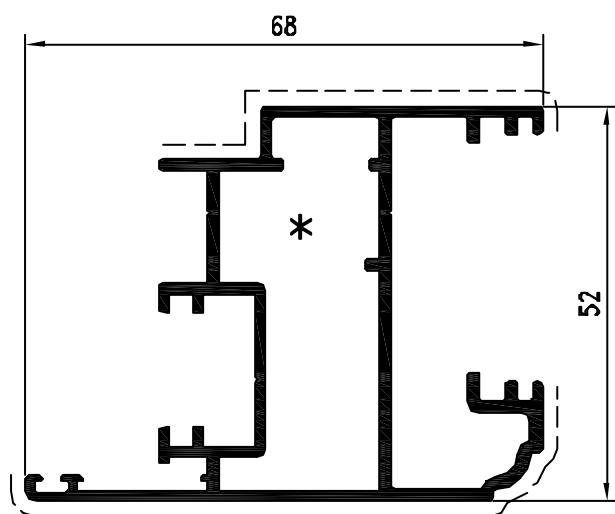

Pr 27394 Kg/m 1.153
sup. in vista mm. 142

* Consigliato con cremonese art. 71C73

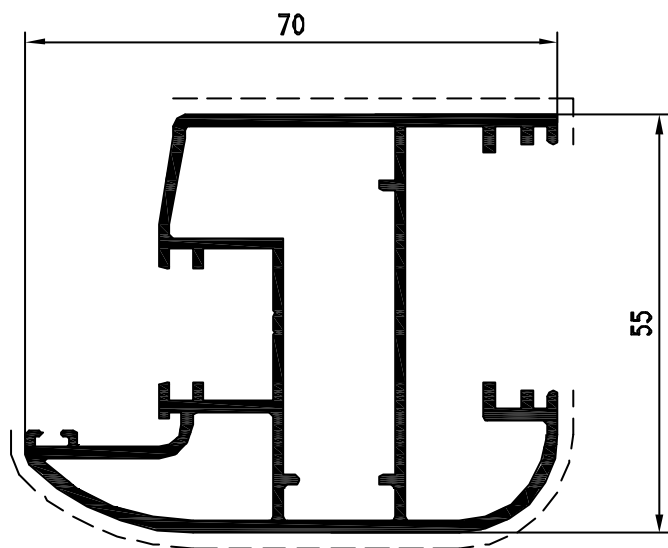

Pr. 34635 kg/m. 1.355
sup. in vista mm. 146

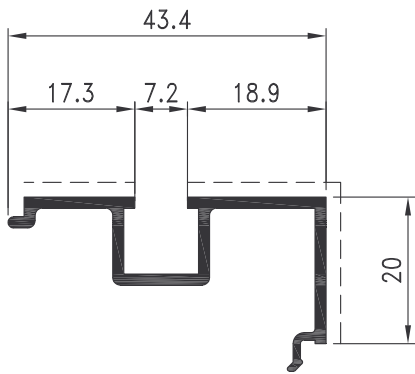

Pr. 24456 kg/m. 0.378
sup. in vista mm. 54

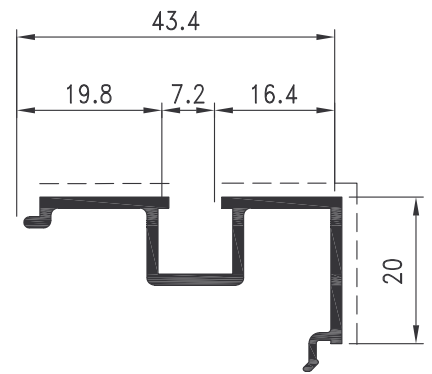

Pr. 24458 kg/m. 0.378
sup. in vista mm. 54

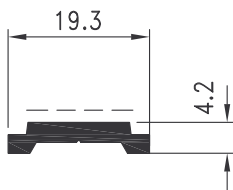

Pr. 11048 kg/m. 0.144
sup. in vista mm. 14

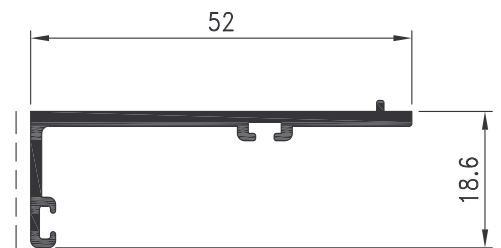

Pr. 60009 kg/m. 0.378
sup. in vista mm. 19

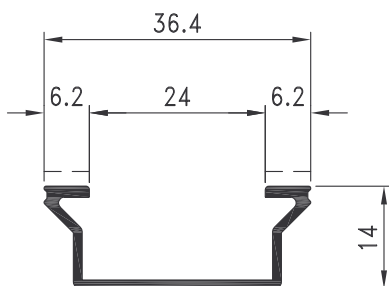

Pr. 60396 kg/m. 0.227
sup. in vista mm. 12

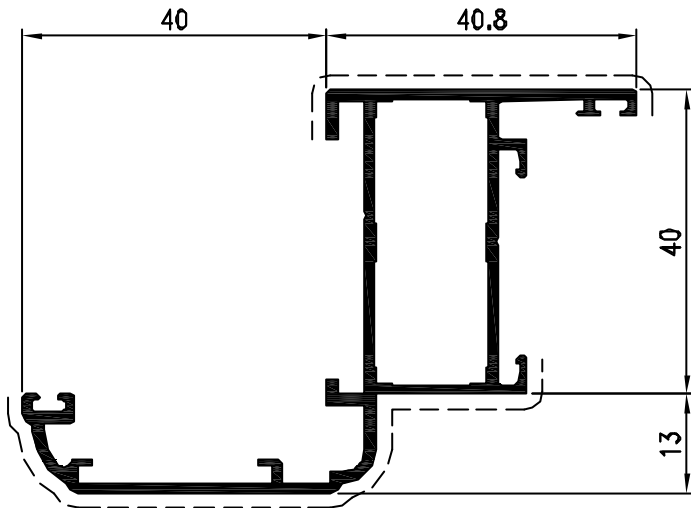

Pr 23328 Kg/m 0.902
sup. in vista mm. 138

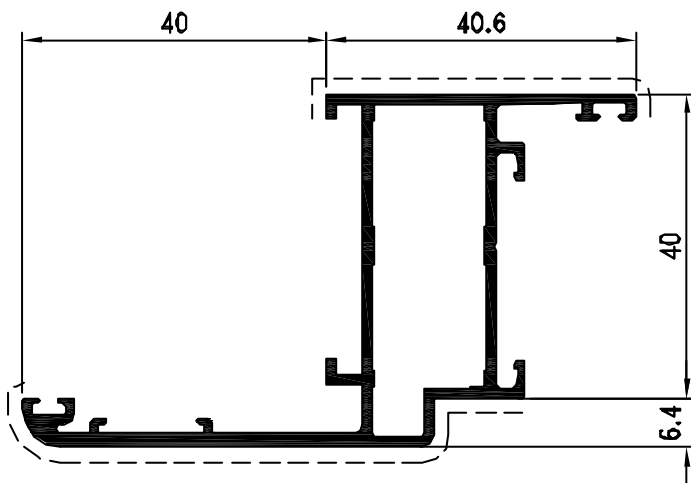

Pr 23341 Kg/m 0.894
sup. in vista mm. 119

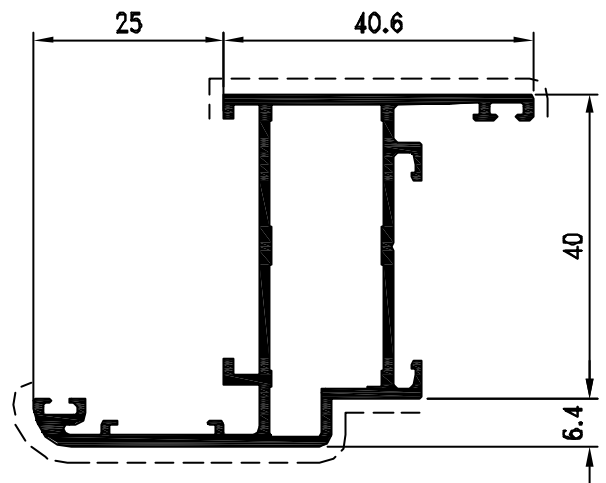

Pr 23342 Kg/m 0.805
sup. in vista mm. 104

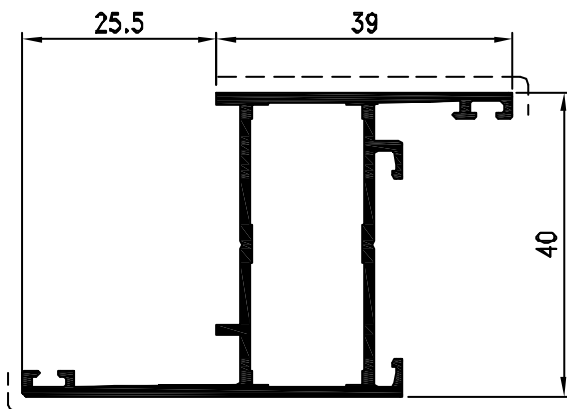

Pr 26200 Kg/m 0.684
sup. in vista mm. 96

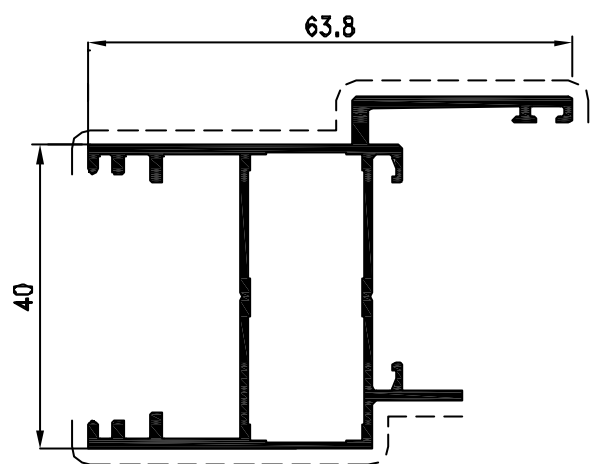

Pr 19723 Kg/m 0.853
sup. in vista mm. 137

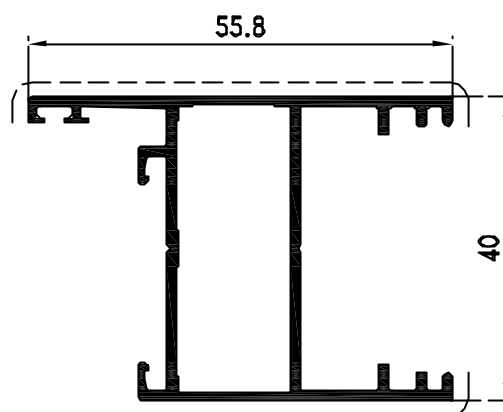

Pr 19724 Kg/m 0.748
sup. in vista mm. 108

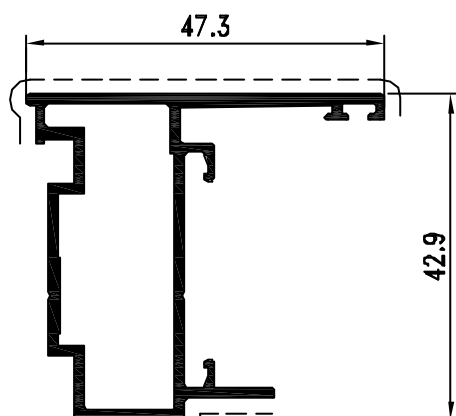

Pr 21688 Kg/m 0.662
sup. in vista mm. 74

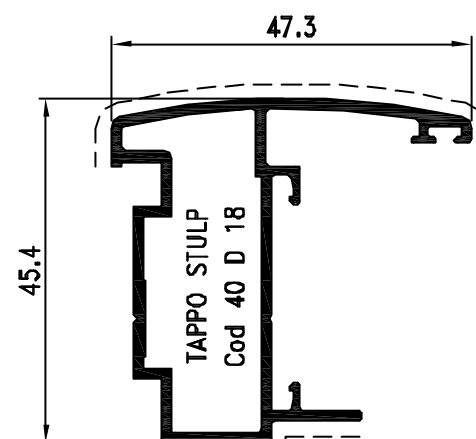

Pr 23339 Kg/m 0.680
sup. in vista mm. 71

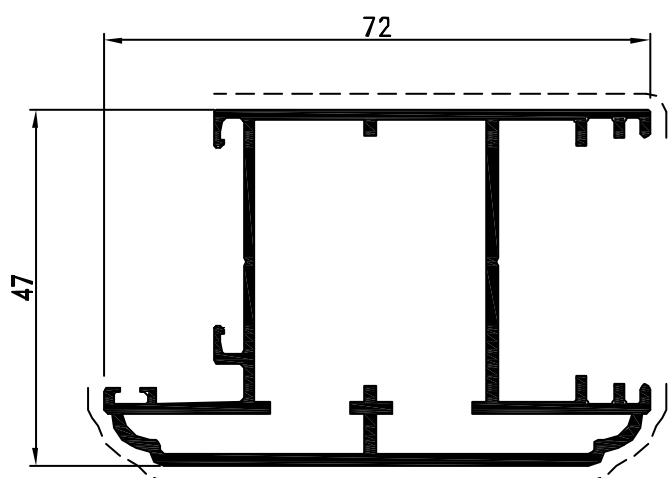

Pr 26235 Kg/m 1.188
sup. in vista mm. 148

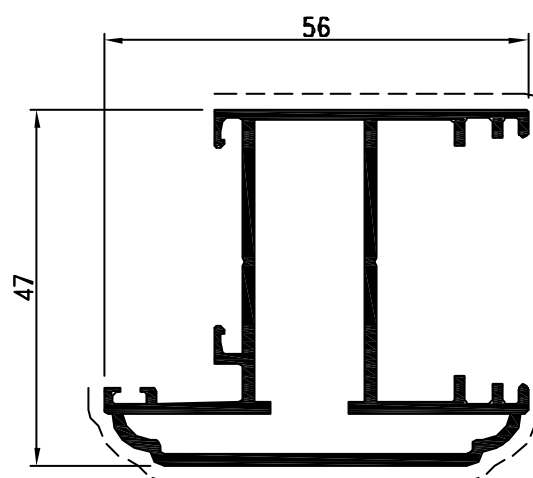

Pr 26236 Kg/m 0.994
sup. in vista mm. 116

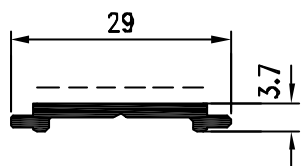

Pr. 19730 kg/m. 0.165
sup. in vista mm. 23

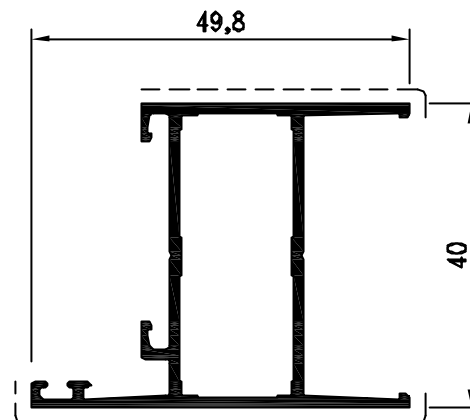

Pr 19741 Kg/m 0.637
sup. in vista mm. 92

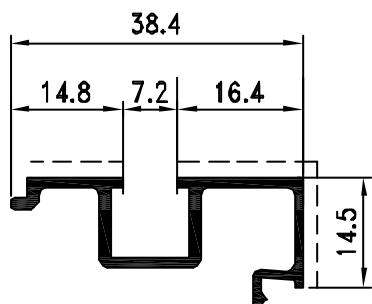

Pr. 26187 kg/m. 0.327
sup. in vista mm. 44

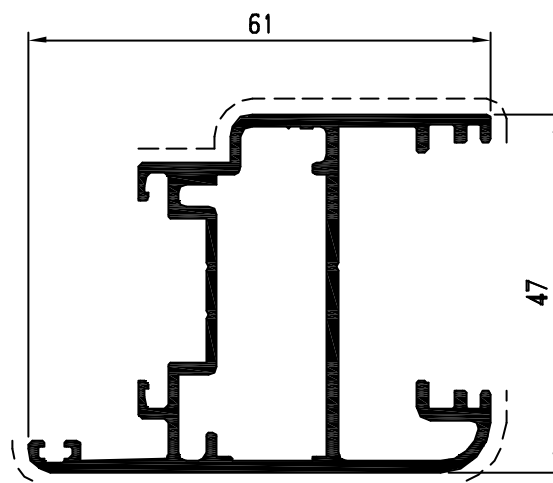

Pr. 27375 kg/m. 1.031
sup. in vista mm. 146

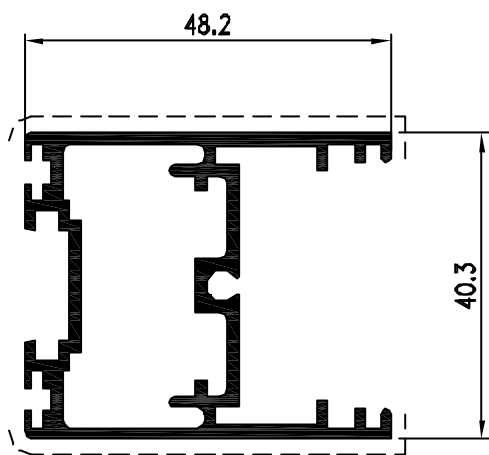

Pr. 16065 kg/m. 0.996
sup. in vista mm. 104

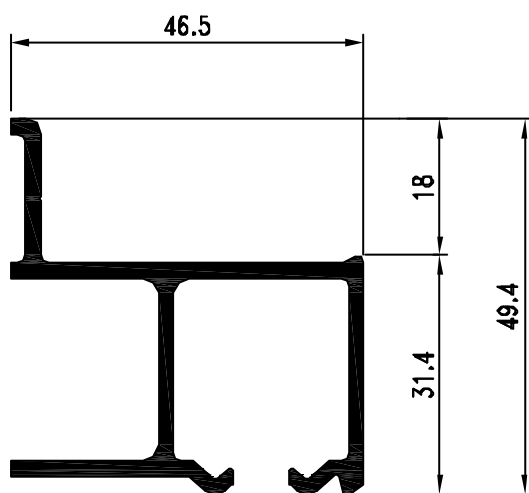

Pr. 16074 kg/m. 0.918
sup. in vista mm. =

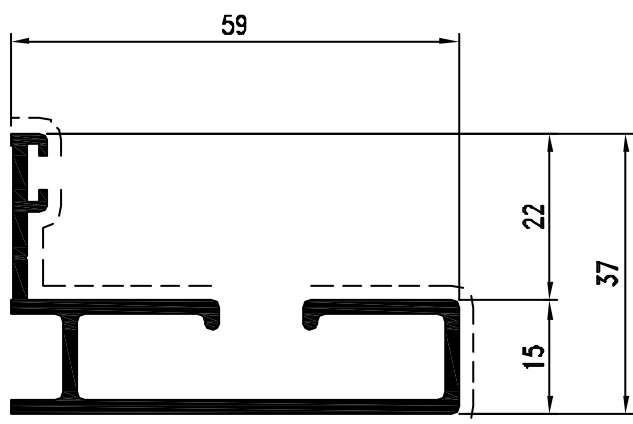

Pr. 16075 kg/m. 0.788
sup. in vista mm. 152

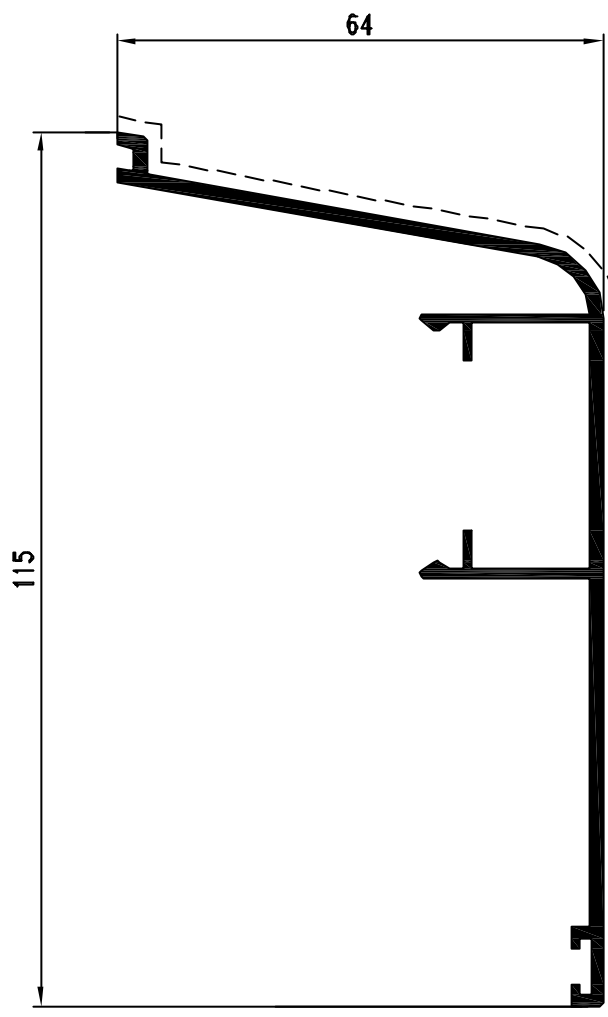

Pr. 16073 kg/m. 0.996
sup. in vista mm. 168

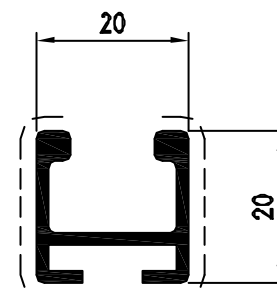

Pr. 16076 kg/m. 0.329
sup. in vista mm. 61

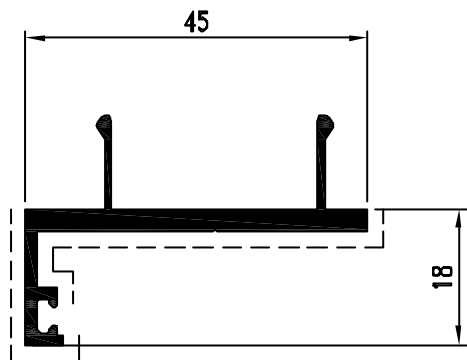

Pr. 16038 kg/m. 0.537
sup. in vista mm. 81

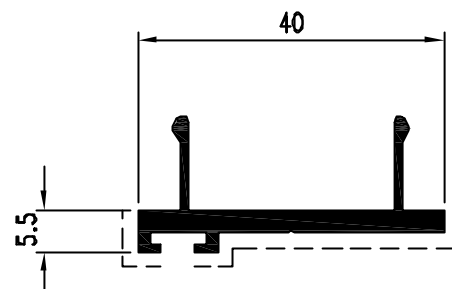

Pr. 16039 kg/m. 0.432
sup. in vista mm. 47

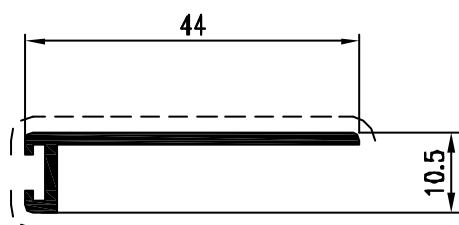

Pr. 16077 kg/m. 0.207
sup. in vista mm. 57

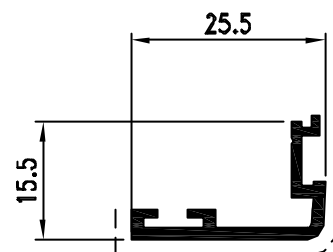

Pr. 19637 kg/m. 0.211
sup. in vista mm. 37

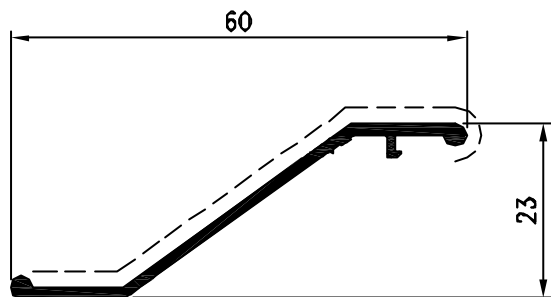

PROFILATO ALETTA FRANGISOLE

Pr. 31931 kg/m. 0.300
sup. in vista mm. 67

PROFILATO BASE MODULARE FRANGISOLE

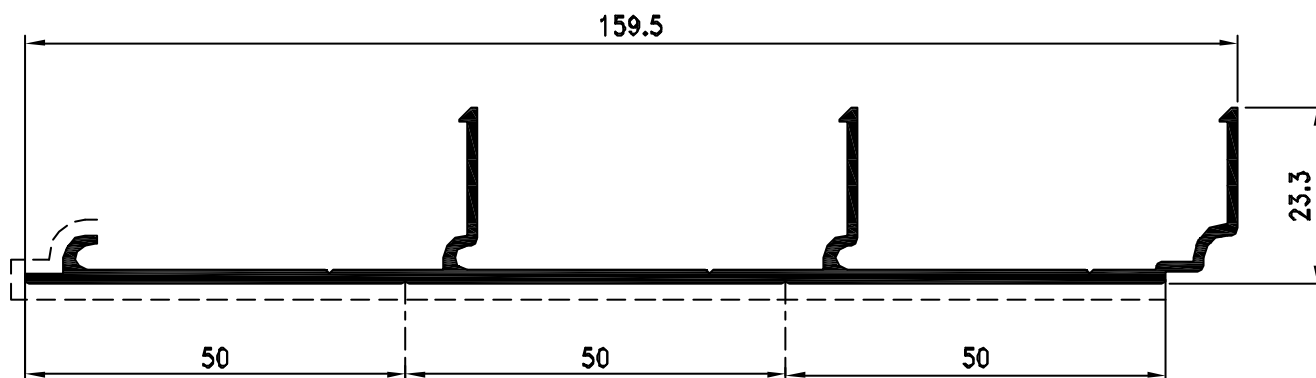

Pr. 31932 kg/m. 1.104
sup. in vista mm. 220

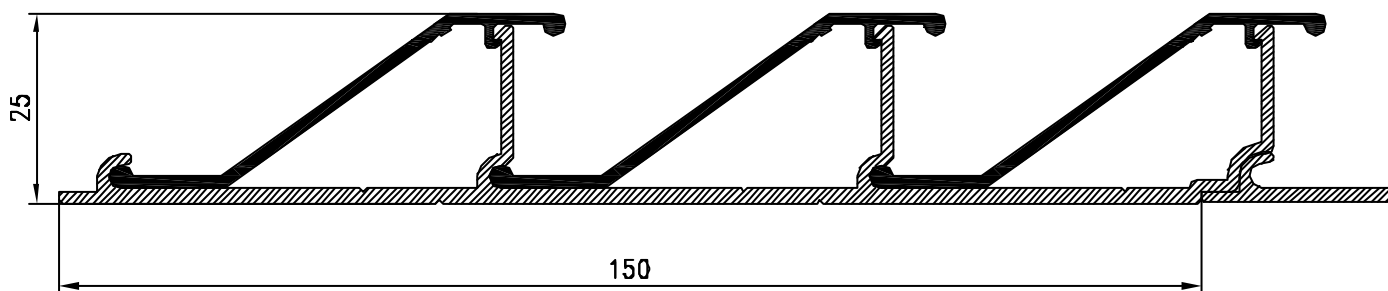

Cod. 30D300 tappi per Pr 34640
Cod. 30D301 registro per Cod. 30D300

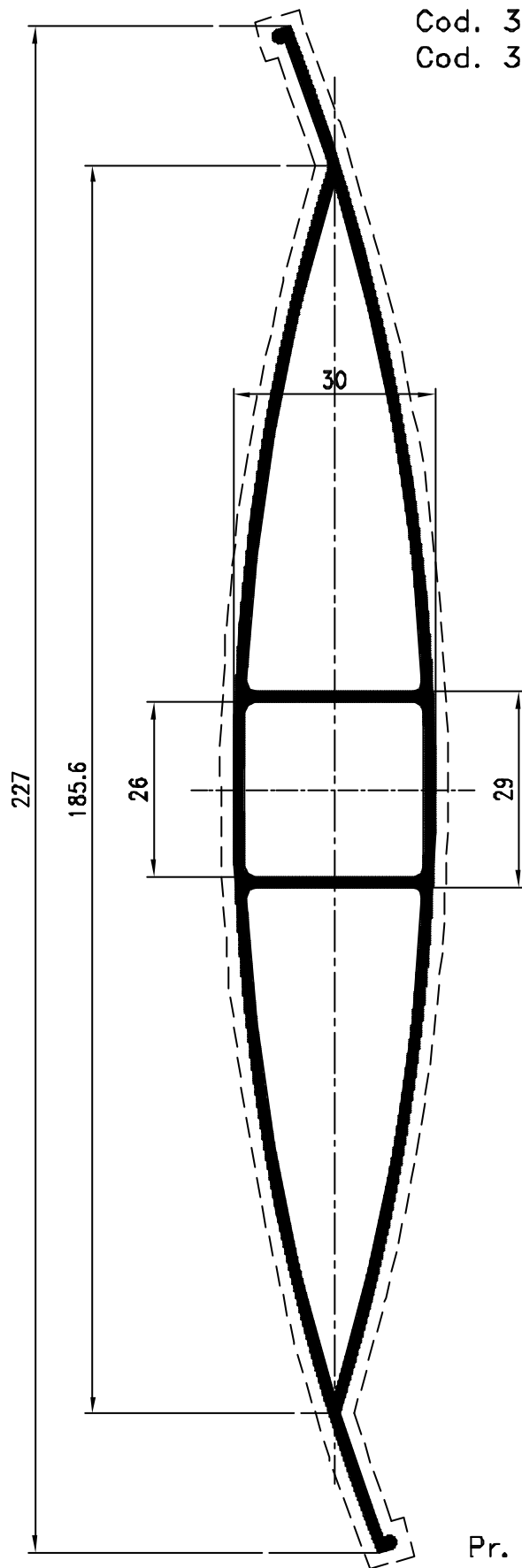

Pr. 34640 kg/m. 1.933
sup. in vista mm. 472

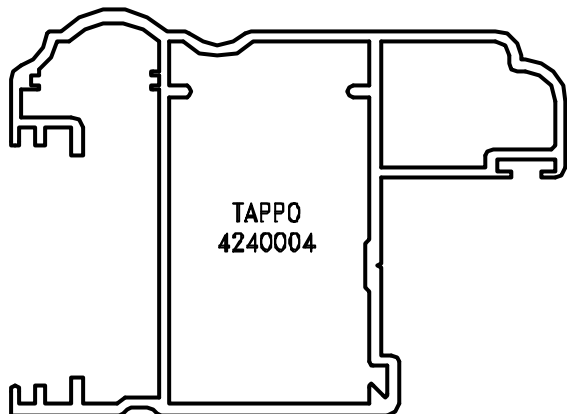

Pr 63003 kg/m. 1,315
sup.in vista mm. 156

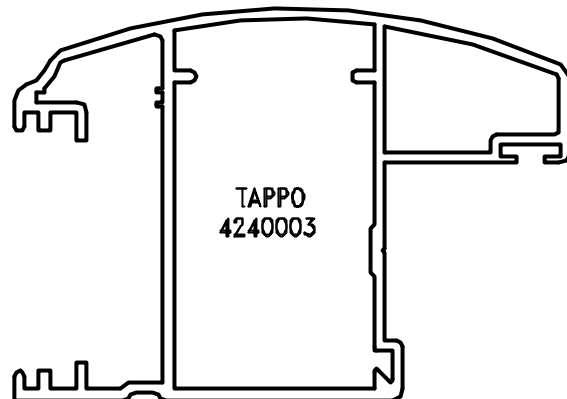

Pr 63004 kg/m. 1,258
sup.in vista mm. 147

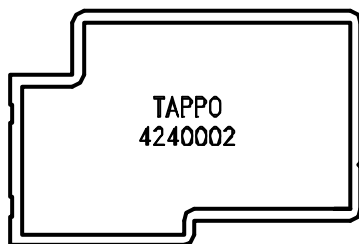

Pr 63001 kg/m. 0,621
sup.in vista mm. 84

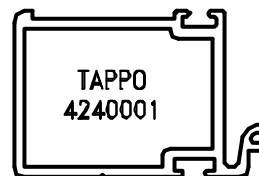

Pr 63002 kg/m. 0,454
sup.in vista mm. 43

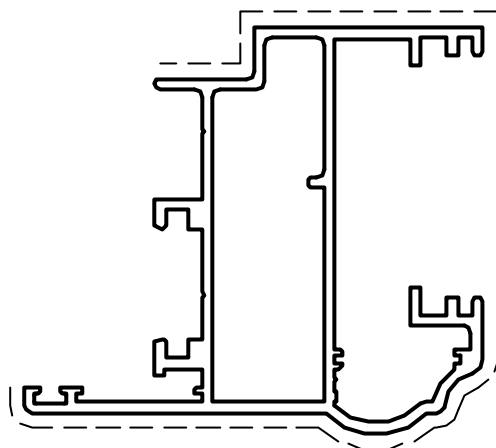

Pr. 3260056 kg/m. 1.080
sup. in vista mm. 130

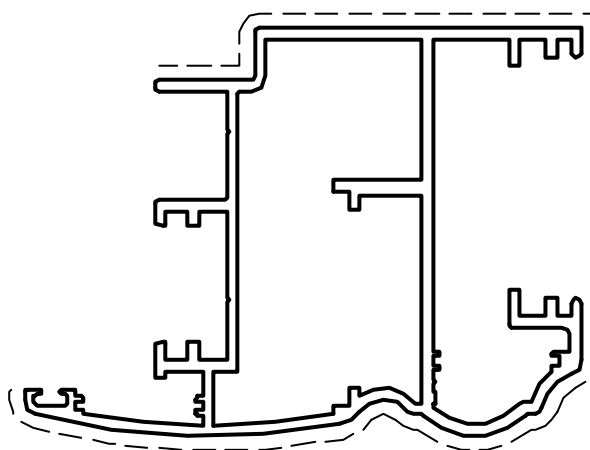

Pr. 3260057 kg/m. 1.340
sup. in vista mm. 161

GELOSIA 1 ANTA STORICA

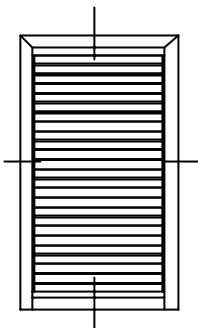

PROFILI

Nr Pezzi	Pr	Descrizione	Taglio
2	27362	Montante anta	H+17,5
1	27382	Traverso anta	L+45
1	16013	Zoccolo	L-99
1	26237	Profilato di finitura zoccolo	L-99
2	27370	Porta lamella di compensazione	L-127
2	27369	Lamella di compensazione	L-120

Pr 27366 lamella "PIANA" Pr 27367 lamella "GOCCIA" Pr 27368 lamella "RUSTICA"

GUARNIZIONI

Codice	Descrizione	Taglio
90 G 97	Guarnizione per battuta	1L+2H
SU G 01	Guarnizione per lamelle	Lx(n.lamelle+1)

FORMULA PER IL CALCOLO DELLA COMPENSAZIONE

LAMELLE FISSE APERTE	
$X = \frac{N \text{ LAMELLE} \times 55 + 117 - \text{LUCE ANTA}}{2}$	
LAMELLE FISSE CHIUSE E LAMELLE ORIENTABILI	
$X = \frac{\text{LUCE ANTA} - \text{MISURA KIT}}{2}$	

ACCESSORI

Nr Pezzi	Codice	Descrizione
2	30 A 21	Squadretta in alluminio pressofuso
2	33 B 100S	Cerniera
2	33 B 109	Cerdine
1	33 C 102	Spagnoletta a scatto
1	33 C 116	Asta 1800 mm
2	33 C 103	Perno
1	33 C 112	Fermaperistano
2	30 D 04	Tappo per traverso Pr 16013
1	30 D 74	Tappo chiavi tubolarita' Pr 27362
2	33 D 100	Rasetta caprifaro
2	33 D 101	Tassello

LAMELLE ORIENTABILI

(H-129,5)-2X 60 1	Codice	Descrizione	Taglio
	27366	LAMELLA 70 mm	L-110
	SP K ..	Meccanismo di movimentazione	

LAMELLE ORIENTABILI

Nr Pezzi	Codice	Descrizione
1	SU K 95	Maniglia margherita

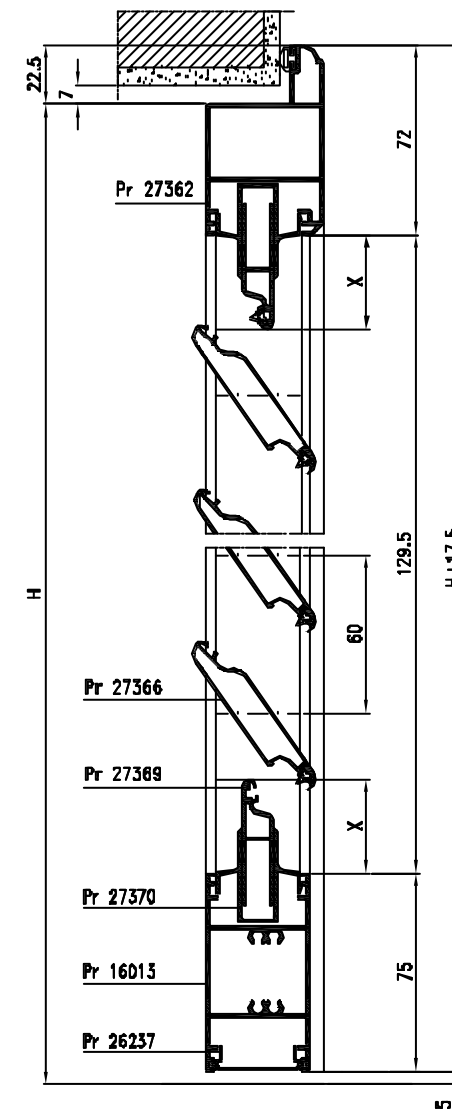
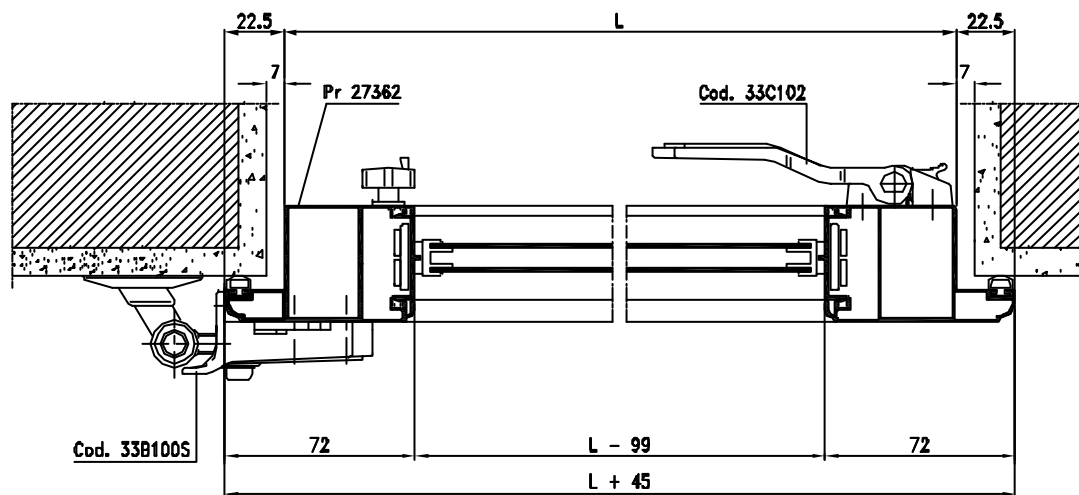

GELOSIA 2 ANTE STORICA

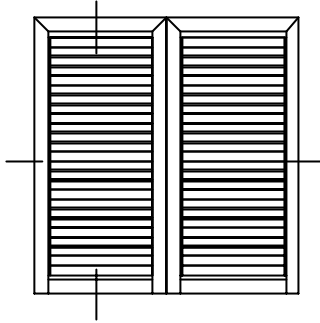

PROFILI

Nr Pezzi	Pr	Descrizione	Taglio
4	27382	Montante anta	H+17.5
2	27362	Traverso anta	L/2+19.5
2	16013	Zoccolo	L/2-124.5
1	24452	Profilato di riparto	H-5
2	26237	Profilato per finitura zoccolo	L/2-124.5
4	27370	Parta lamella di compensazione	L/2-162.5
4	27389	Lamella di compensazione	L/2-162.5

Pr 27366 lamella "PIANA" Pr 27367 lamella "GOCCIA" Pr 27368 lamella "RUSTICA"

GUARNIZIONI

Codice	Descrizione	Taglio
90 G 97	Guarnizione per battuta	1L+3H
SU G 01	Guarnizione per lamelle	L/2x(n.lamelle+1)

FORMULA PER IL CALCOLO DELLA COMPENSAZIONE

$$X = \frac{N \text{ LAMELLE} \times 55 + 117 - \text{LUCE ANTA}}{2}$$

LAMELLE FISSE APERTE

LAMELLE FISSE CHIUSE E LAMELLE ORIENTABILI

$$X = \frac{\text{LUCE ANTA} - \text{MISURA KIT}}{2}$$

ACCESSORI

Nr Pezzi	Codice	Descrizione
4	30 A 21	Squacretta in alluminio pressofuso
2	33 B 1000	Cerniera dx
2	33 B 1005	Cerniera sx
4	33 B 101	Bandella verticale per cerniera
4	33 B 109	Cardine
1	33 C 100	Spagnoletta 2 ante
1	33 C 104	Piastra di chiusura
1	33 C 103	Perno
2	33 C 112	Fermapersiana
1	33 C 118	Asta 1800 mm
4	30 D 04	Tappo per traverso Pr 16013
2	30 D 74	Tappo chiudi tubolaria Pr 27382
1	33 D 02	Tappo chiudi tubolaria Pr 24452
4	33 D 100	Rosetta copritraro cardine
4	33 D 101	Tassello

LAMELLE ORIENTABILI

	Codice	Descrizione	Taglio
$\left[\frac{H-129.5}{60} - 2X \right] \times 2$	27386	LAMELLA 70 mm	L/2-135.5
	SP K ..	Meccanismo di movimentazione	

LAMELLE ORIENTABILI

Nr Pezzi	Codice	Descrizione
2	SU K 95	Maniglia margherita

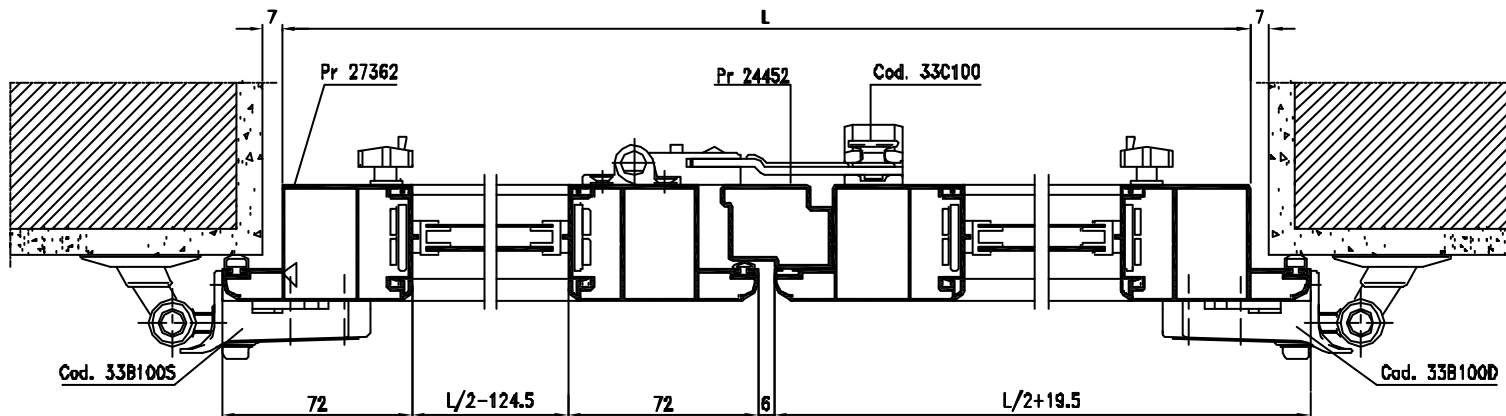
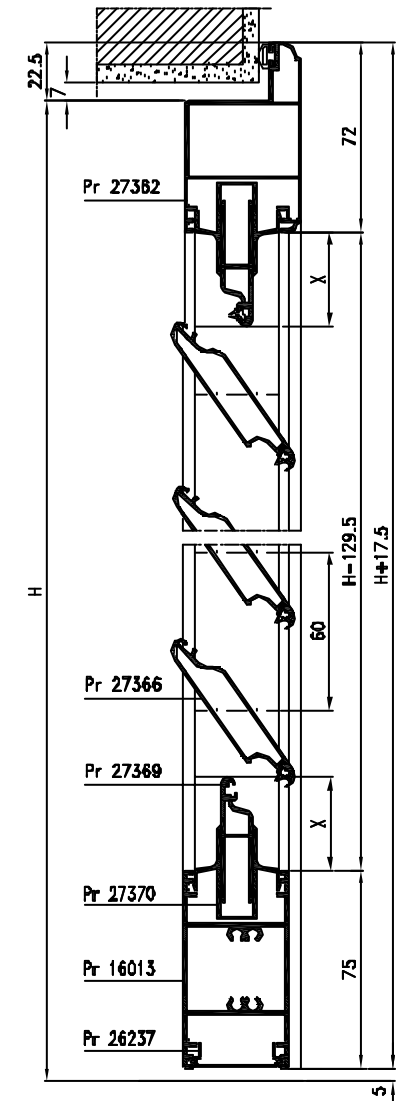



GELOSIA 1 ANTA STORICA

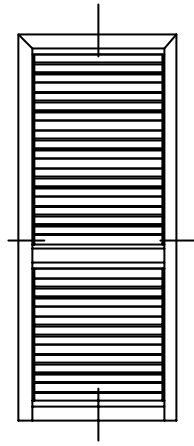

PROFILI

Nr Pezzi	Pr	Descrizione	Taglio
2	27362	Montante anta	HH-17,5
1	27362	Traverso anta	L+45
2	16013	Zoccolo - Fascia	L-99
1	26237	Profilato di finitura zoccolo	L-99
2	27370	Porta lamella di compensazione	L-127
2	27369	Lamella di compensazione	L-120

Pr 27366 lamella "PIANA" Pr 27367 lamella "GOCCIA" Pr 27368 lamella "RUSTICA"

GUARNIZIONI

Codice	Descrizione	Taglio
90 G 97	Guarnizione per battuto	1L+2H
SU G 01	Guarnizione per lamelle	Lx(n.lamelle+2)

FORMULA PER IL CALCOLO DELLA COMPENSAZIONE

LAMELLE FISSE APERTE

$$X = \frac{N^{\circ} \text{ LAMELLE} \times 55 + 117 - \text{LUCE ANTA}}{2}$$

LAMELLE FISSE CHIUSE E LAMELLE ORIENTABILI

$$X = \frac{\text{LUCE ANTA} - \text{MISURA KIT}}{2}$$

ACCESSORI

Nr Pezzi	Codici	Descrizione
2	30 A 21	Squadreria in alluminio pressofuso
3	33 B 099S	Cerniera sx
3	33 B 101	Bandella verticale per cerniera
3	33 B 109	Cardine
3	33 D 100	Rosetta capriforo cardine
3	33 D 101	Tassello
1	33 C 101	Spagnoletta 1 anta
1	33 C 117	Asta 2400mm
2	33 C 103	Perno
1	33 C 112	Fermaperistano
4	30 D 04	Tappo per traverso Pr 16013
1	30 D 74	Tappo chiusi tubolarita' Pr 27362

LAMELLE ORIENTABILI

	Codice	Descrizione	Taglio
$\frac{(H-H_{inf})-51,5}{60}$	27366	LANELLA 70 mm	L-110
1	SP K ..	Meccanismo di movimentazione	

LAMELLE FISSE

	Codice	Descrizione	Taglio
$\frac{[(H_{inf}-155)-2x]}{60}$	27366	LANELLA 70 mm	L-83
1			

LAMELLE ORIENTABILI

Nr Pezzi	Codice	Descrizione
2	SU K 95	Maniglia margherita

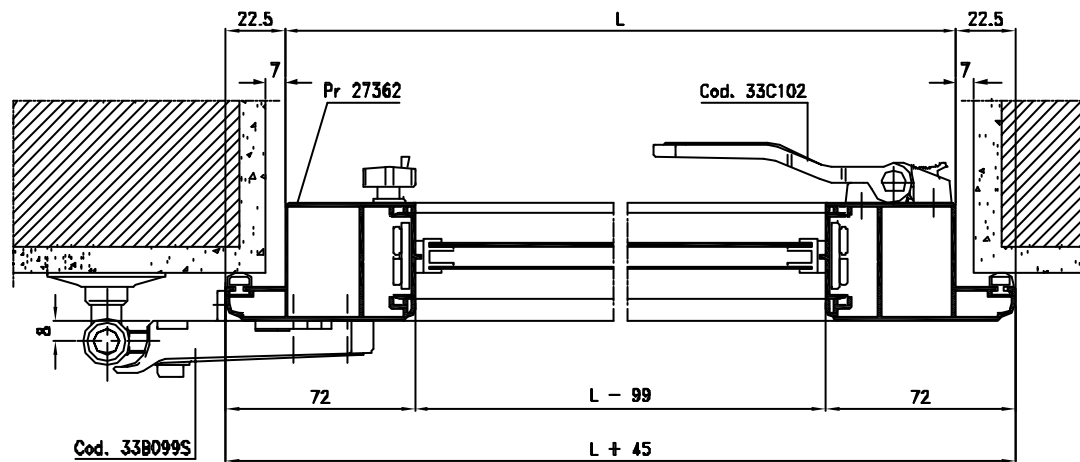
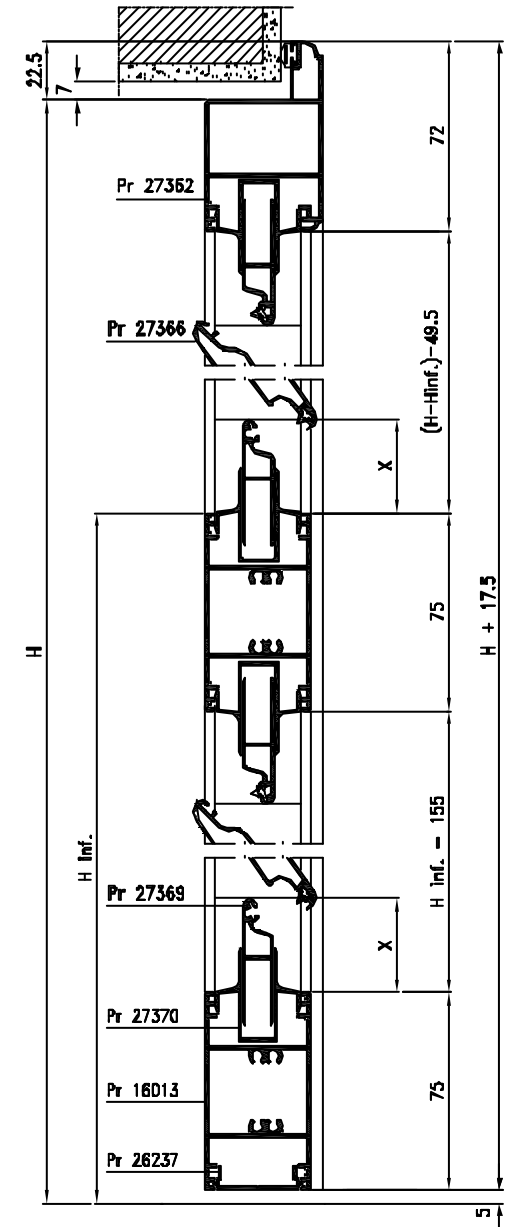

Cod. 33B099S



GELOSIA 2 ANTE STORICA

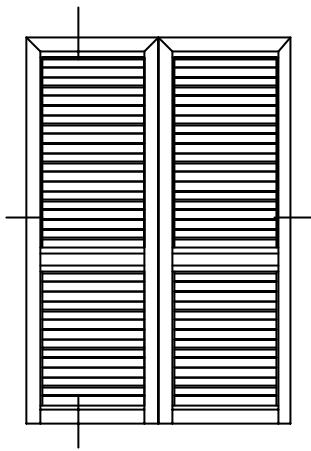

PROFILI

Nr Pezzi	Pr	Descrizione	Taglio
4	27362	Montante anta	H-17,5
2	27362	Traverso anta	L/2+19,5
2	18013	Zoccolo - Faccia	L/2-124,5
1	24452	Profilato di riparto	H-5
2	28237	Profilato per finitura zoccolo	L/2-124,5
4	27370	Porta lamella di compensazione	L/2-152,5
4	27389	Lamella di compensazione	L/2-145,5

Pr 27366 lamella "PANA" Pr 27367 lamella "COCCIA" Pr 27368 lamella "RUSTICA"

GUARNIZIONI

Codice	Descrizione	Taglio
90 G 97	Guarnizione per battuta	1L+3H
SU G 01	Guarnizione per lamelle	L/2x(nLamelle+4)

FORMULA PER IL CALCOLO DELLA COMPENSAZIONE

LAMELLE FISSE APERTE

$$X = \frac{N^{\circ} \text{ LAMELLE} \times 55 + 117 - \text{LUCE ANTA}}{2}$$

LAMELLE FISSE CHIUSE E LAMELLE ORIENTABILI

$$X = \frac{\text{LUCE ANTA} - \text{MISURA KIT}}{2}$$

LAMELLE FISSE

Nr Pezzi	Codice	Descrizione	Taglio
$\frac{(H_{\text{inf}} - 155) - 2x}{1}$	27366	LAMELLA 70 mm	L/2-83

ACCESSORI

Nr Pezzi	Codice	Descrizione
4	3D A 21	Sguocchetta in alluminio pressofuso
3	33 B 1000	Cerniera dx
3	33 B 100S	Cerniera sx
6	33 B 101	Bandella verticale per cerniera
6	33 B 109	Cardine
6	33 D 100	Rosetta coprifora cardine
6	33 D 101	Tassello
1	33 C 100	Spagnoletta 2 ante
2	33 C 105	Guida aste
1	33 C 117	Asta 2400 mm
1	33 C 103	Perno
1	33 C 104	Plastra di chiusura
2	33 C 112	Fermapersiana
8	30 D 04	Tappe per traverso Pr 16013
2	30 D 74	Tappe chiudi tubolarita' Pr 27362
1	33 D 02	Tappe chiudi tubolarita' Pr 24452

LAMELLE ORIENTABILI

Nr Pezzi	Codice	Descrizione	Taglio
$\frac{(H - H_{\text{inf}}) - 49,5}{80} - 2x$	27366	LAMELLA 70 mm	L/2-135,5
1	SP K ..	Meccanismo di movimentazione	

LAMELLE ORIENTABILI

Nr Pezzi	Codice	Descrizione
4	SU K 95	Maniglia margherita

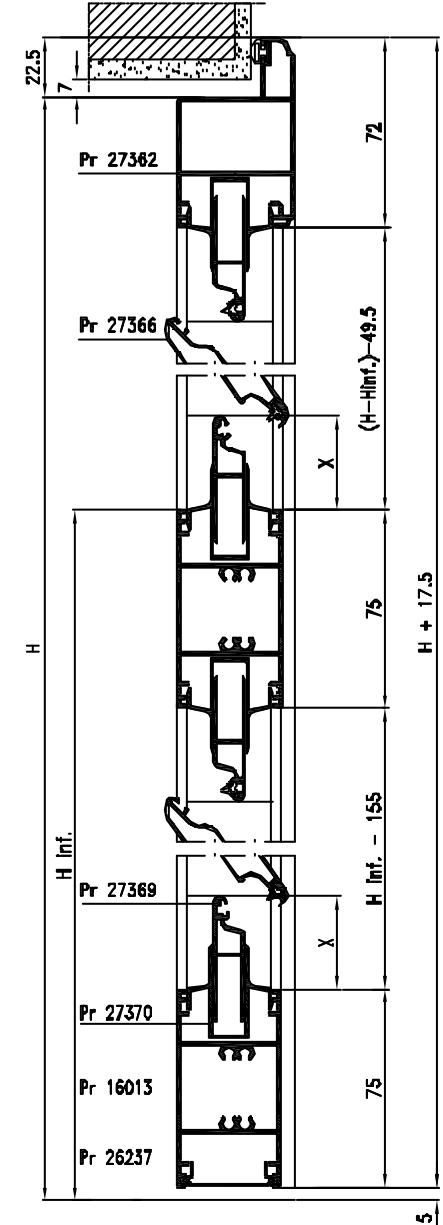
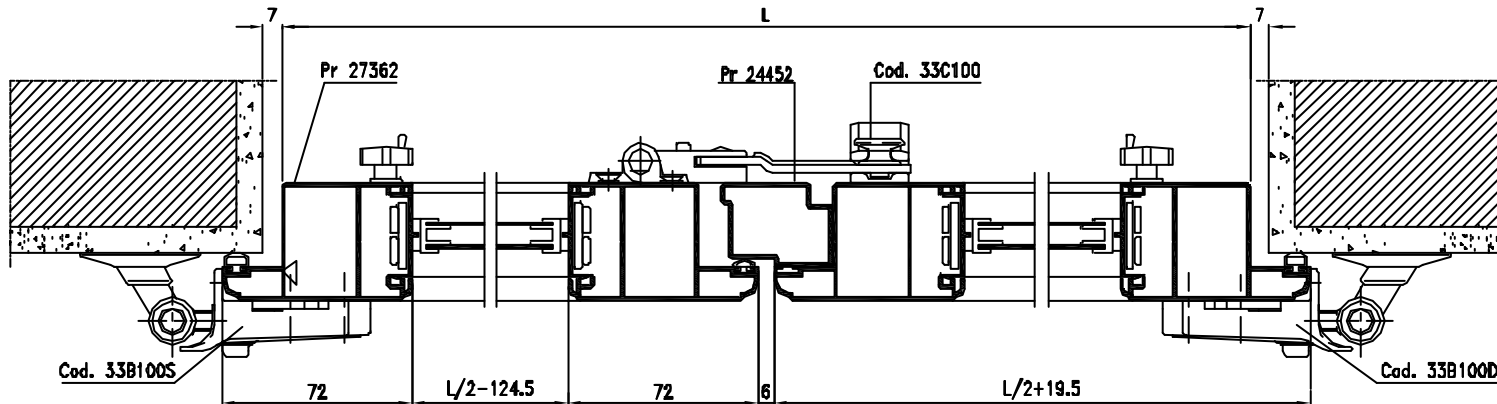

PROSPETTO ESTERNO PERSIANA 2 ANTE

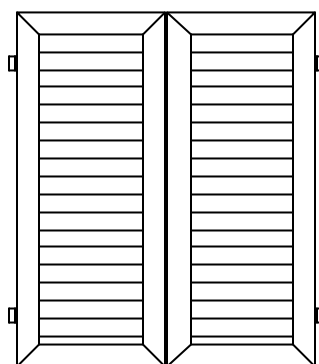

PROFILATI

Nr. Pezzi	Pr	Descrizione	Taglio
4	63003	Montante anta	H+8,5
4	63003	Traverso anta	L/2+12,5
1	63001	Riporto centrale	H-38,5
1	63002	Riporto inferiore prima anta	L/2-38,5
1	63002	Riporto inferiore seconda anta	L/2+8,5
4	27370	Porta lamella di compensazione	L/2-137,5
4	27369	Lamella di compensazione	L/2-137,5

FORMULA PER IL CALCOLO DELLA COMPENSAZIONE

LAMELLE FISSE APERTE
$X = \frac{\text{LUCE ANTA} - (\text{N}^{\circ} \text{ LAMELLE} \times 55 + 117)}{2}$
LAMELLE FISSE CHIUSE E LAMELLE OREINTABILI
$X = \frac{\text{LUCE ANTA} - \text{MISURA KIT}}{2}$

LAMELLE ORIENTABILI

Nr Pezzi	Codice	Descrizione	Taglio
$\frac{(H-141,5)-2X}{60} \times 2$	27366	# Lamella PIANA da 70 mm	L/2+148,5
2	SP K ..	Meccanismo di movimentazione	
2	SU K 95	Maniglia margherita	

in alternativa Pr 27367 lamella GOCCIA - Pr 27368 lamella RUSTICA

ACCESSORI

Nr. Pezzi	Codici	Descrizione
8	30 A 21	Squadretta anta
8	13 A 03	Squadretta di allineamento anta
1	33 C 99	Confezione base spagnoletta grande (x 2 ante)
2	33 C 104	Plastra di chiusura ad angolo
2	33 C 112	Fermolimposta automatico a muro
1*	33 C 116	Asta di chiusura L=1800mm
2 coppie	4240001	Tappo per Pr 63002
1 coppia	4240002	Tappo per Pr 63001

* In alternativa Cod.33 C 117 L=2400mm., Cod. 33 C 11B L=3200mm.

GUARNIZIONI

Codici	Descrizione	Taglio
90 G 31	Guarnizione per spessoramento Pr 63002	L
90 G 97	Guarnizione di battuta anta	3H + 1L
90 S 65	Spazzolino da 5 x 9 per Pr 63002	L
SU G 01	Guarnizione per lamelle	L/2x(n.lamelle+1)

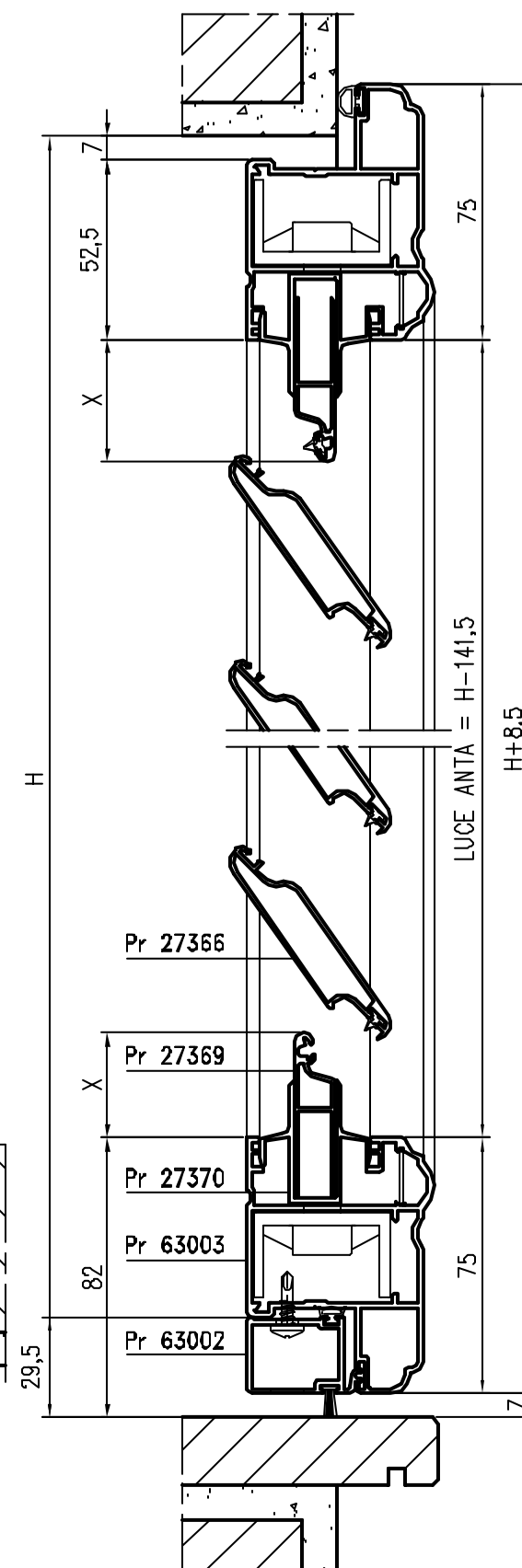
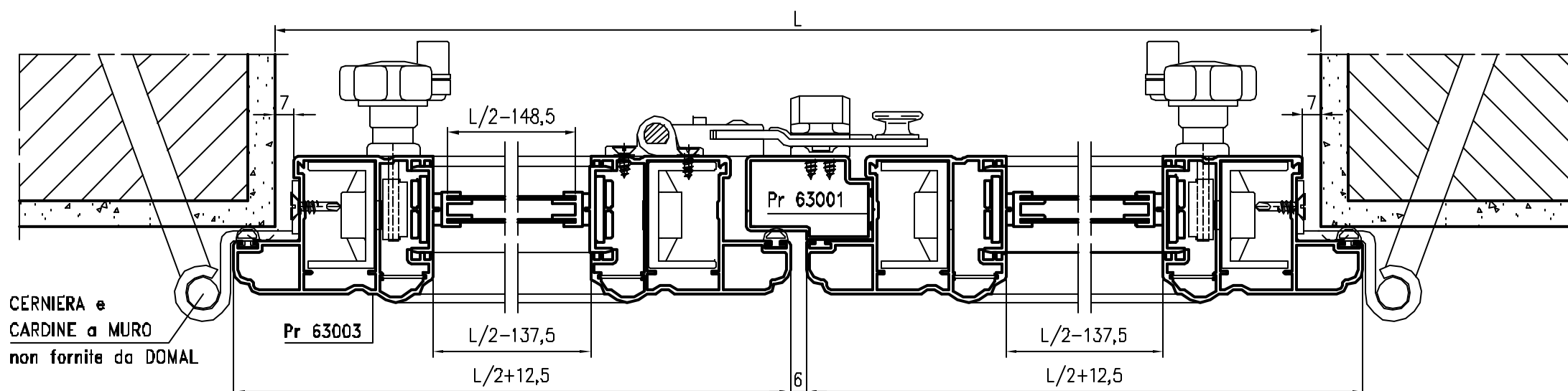

PROSPETTO ESTERNO

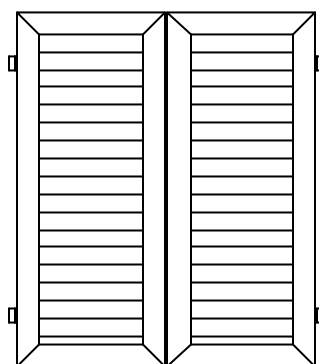

PERSIANA 2 ANTE

PROFILATI

Nr. Pezzi	Pr	Descrizione	Taglio
4	63004	Montante anta	H+8,5
4	63004	Traverso anta	L/2+12,5
1	63001	Riporto centrale	H-38,5
1	63002	Riporto inferiore prima anta	L/2-38,5
1	63002	Riporto inferiore seconda anta	L/2+8,5
4	27370	Porta lamella di compensazione	L/2-137,5
4	27369	Lamella di compensazione	L/2-137,5

FORMULA PER IL CALCOLO DELLA COMPENSAZIONE

LAMELLE FISSE APERTE
$X = \frac{\text{LUCE ANTA} - (N^{\circ} \text{ LAMELLE} \times 55 + 117)}{2}$
LAMELLE FISSE CHIUSE E LAMELLE OREINTABILI
$X = \frac{\text{LUCE ANTA} - \text{MISURA KIT}}{2}$

LAMELLE ORIENTABILI

Nr Pezzi	Codice	Descrizione	Taglio
$\frac{(H-141,5)-2X}{60} \times 2$	27366	# Lamella PIANA da 70 mm	L/2+148,5
2	SP K ..	Meccanismo di movimentazione	

In alternativa Pr 27367 lamella GOCCIA - Pr 27368 lamella RUSTICA

LAMELLE ORIENTABILI

Nr Pezzi	Codice	Descrizione
2	SU K 95	Maniglia margherita

ACCESSORI

Nr. Pezzi	Codici	Descrizione
8	3D A 21	Squadretta anta
8	13 A 03	Squadretta di allineamento anta
1	33 C 99	Confezione base spagnoletta grande (x 2 ante)
2	33 C 104	Plastra di chiusura ad angolo
2	33 C 112	Fermolimpasta automatico a muro
1*	33 C 116	Asta di chiusura L=1800mm
2 coppie	4240001	Tappo per Pr 63002
1 coppia	4240002	Tappo per Pr 63001

* In alternativa Cod.33 C 117 L=2400mm., Cod. 33 C 11B L=3200mm.

GUARNIZIONI

Codice	Descrizione	Taglio
90 G 31	Guarnizione per spessoramento Pr 63002	L
90 G 97	Guarnizione di battuta anta	3H + 1L
90 S 65	Spazzolino da 5 x 9 per Pr 63002	L
SU G 01	Guarnizione per lamelle	L/2x(n.lamelle+1)

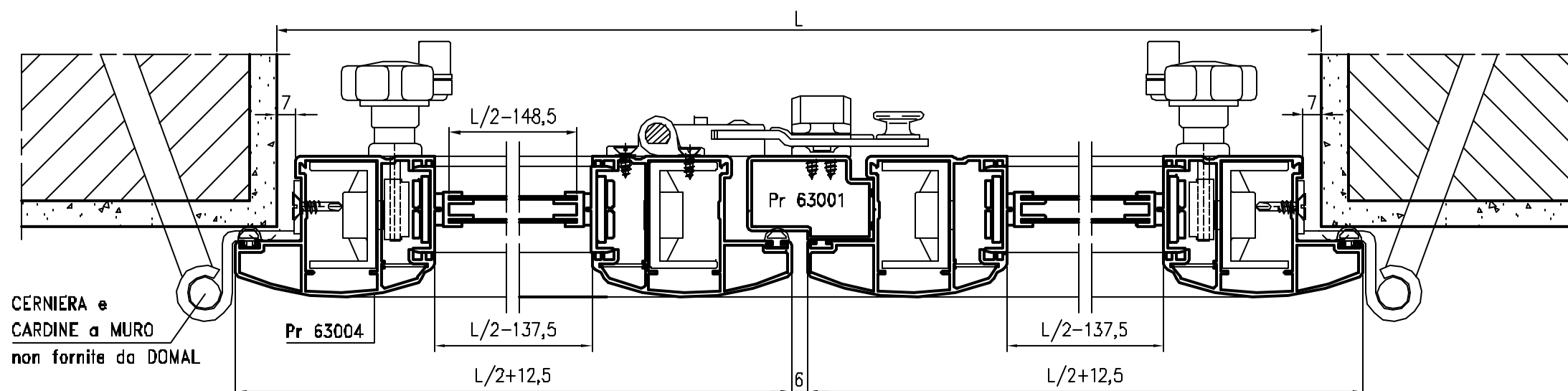

CERNIERA e
CARDINE a MURO
non fornite da DOMAL

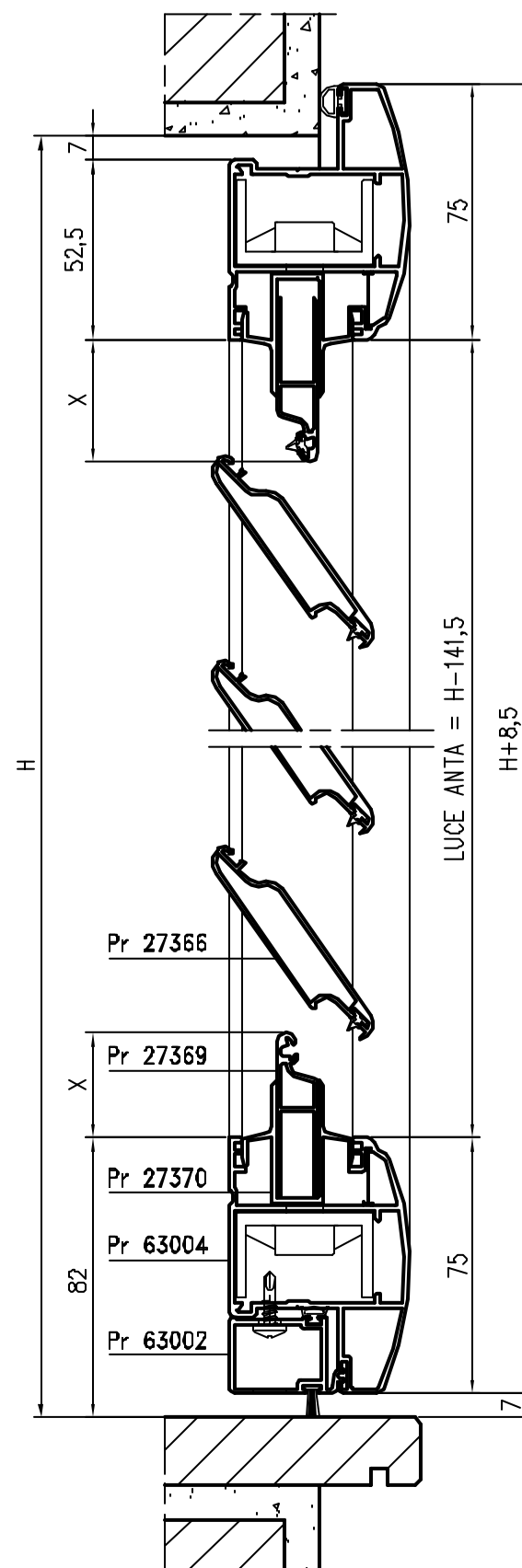



GELOSIA 1 ANTA Abbinamento DOMAL STOPPER PG

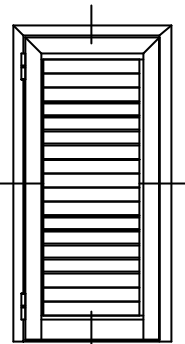

PROFILI

Nr Pezzi	Pr	Descrizione	Taglio
2	19714	Montante telaio	H-22
1	19714	Traverso telaio	L+44
2	24457	Montante anta	H-29
1	24457	Traverso anta	L-48
1	16013	Zoccolo	L-131.6
1	13027	Gocciolatoio	L+44
1	11048	Asta di chiusura	(H)
2	27370	Porta lamella di compensazione	L-189.6
2	27369	Lamella di compensazione	L-192.6
1	26237	Profilato di finitura zoccolo	L-171.6

Pr 27366 lamella "PIANA" Pr 27367 lamella "GOCCIA" Pr 27368 lamella "RUSTICA"

GUARNIZIONI

Codice	Descrizione	Taglio
ST G 29	Guarnizione per battuta	2L+4H
SU G 01	Guarnizione per lamelle	Lx(nlamelle+1)

FORMULA PER IL CALCOLO DELLA COMPENSAZIONE

$$X = \frac{\text{LAMELLE FISSE APERTE} \times \text{N° LAMELLE} \times 55 + 117 - \text{LUCE ANTA}}{2}$$

LAMELLE FISSE CHIUSE E LAMELLE ORIENTABILI

$$X = \frac{\text{LUCE ANTA} - \text{MISURA KIT}}{2}$$

ACCESSORI

Nr Pezzi	Codice	Descrizione
4	13 E 03	Espansore di regolazione
4	13 A 21	Squadretta in alluminio pressofuso
2	71 B 61	Cerniera reversibile terza anta
1	71 C 73	Cremonese MAXIMA per aperture int./est. (dx)
1	13 C 15	Blochetti di collegamento
1	71 D 20	Incontro per asta e terza chiusura
2	71 D 21	Terminale per asta di chiusura
1	80 D 17	Boccola
1	13 D 44	Tappo chiudi tubolarità per Pr 24457
2	30 D 04	Tappo traverso Pr 16013

LAMELLE ORIENTABILI

	Codice	Descrizione	Taglio
{H-165.8}-2X 60	27366	LAMELLA 70 mm	L-182.6
1	SP K ...	Meccanismo di movimentazione	

LAMELLE ORIENTABILI

Nr Pezzi	Codice	Descrizione
1	SU K 95	Maniglia margherita

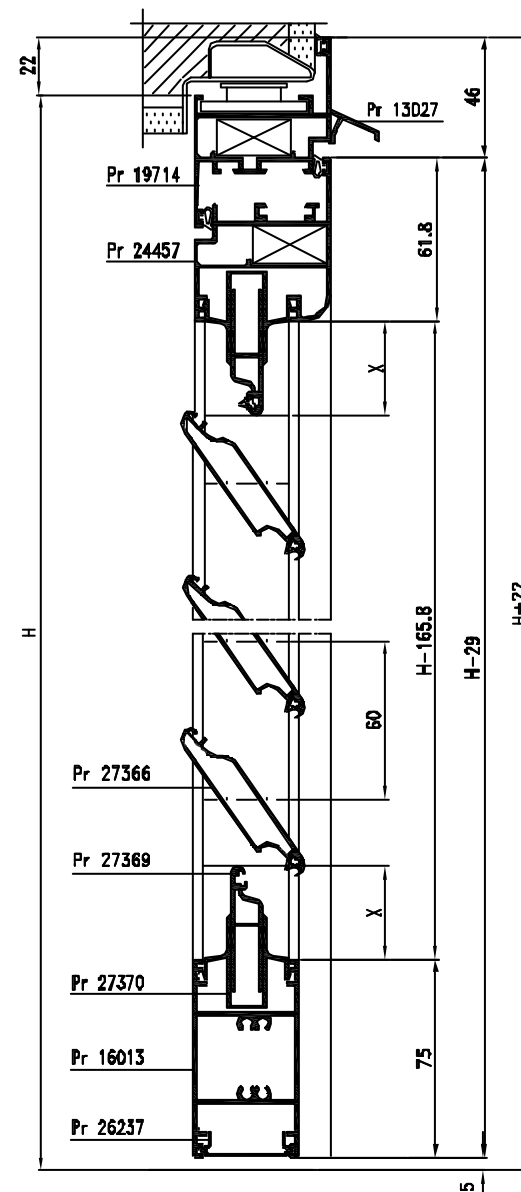
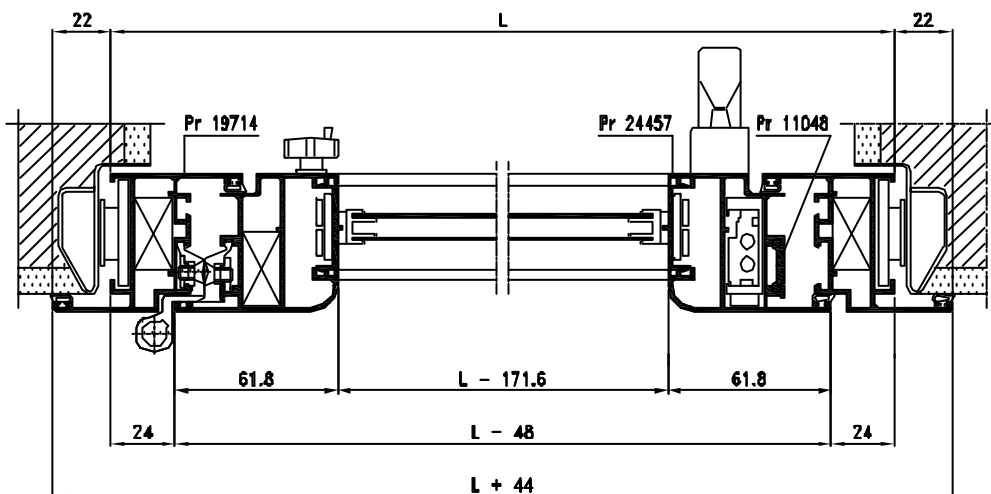

GELOSIA 2 ANTE Abbinamento DOMAL STOPPER PG

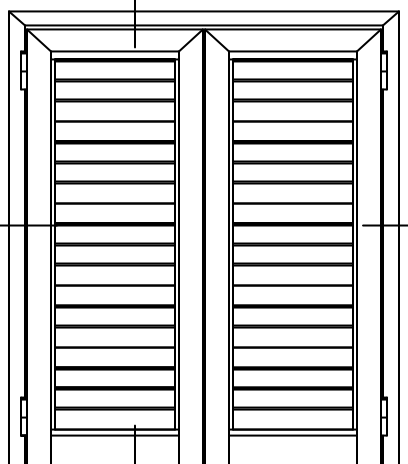

PROFILI

Nr Pezzi	Pr	Descrizione	Taglio
2	19714	Montante telaio	H+22
1	19714	Traverso telaio	L+44
4	24457	Montante anta	H-35.5
2	24457	Traverso anta	L/2-26.7
1	19663	Riparto centrale	H-86.5
1	16013	Zoccolo	L/2-110.3
1	13027	Gocciolatoio	L+44
1	11048	Asta di chiusura	(H)
4	27370	Porta lamella di compensazione	L/2-178.3
4	27369	Lamella di compensazione	L/2-171.3
2	26237	Prfilato di finitura zoccolo	L/2-150.3

Pr 27366 lamella "PIANA" Pr 27367 lamella "GOCCIA" Pr 27368 lamella "RUSTICA"

GUARNIZIONI

Codice	Descrizione	Taglio
ST G 29	Guarnizione per battuta	3L+6H
SU G 01	Guarnizione per lamelle	L/2x(n.lamelle+1)

FORMULA PER IL CALCOLO DELLA COMPENSAZIONE

LAMELLE FISSE APERTE	
$X = \frac{N \text{ LAMELLE} \times 55 + 117 - \text{LUCE ANTA}}{2}$	
LAMELLE FISSE CHIUSE E LAMELLE ORIENTABILI	
$X = \frac{\text{LUCE ANTA} - \text{MISURA KIT}}{2}$	

ACCESSORI

Nr Pezzi	Codice	Descrizione
6	13 E 03	Espansore di regolazione
6	13 A 21	Squadretta in alluminio pressofuso
1	13 D 31	Tappo per profilato di riparto Pr 19663
4	71 B 61	Cerniera reversibile terza anta
1	71 C 73	Cremonese MAXIMA per aperture int/est. (dx)
1	13 G 15	Blocchetti di collegamento
1	71 D 20	Incontra per asta e terza chiusura
2	71 D 21	Terminale per asta di chiusura
1	80 D 17	Boccola
2	13 D 44	Tappo chiudi tubolarita' per Pr 24457
1	13 D 22	Tappo chiudi tubolarita' per Pr 19663
4	30 D 04	Tappo traverso Pr 16013

LAMELLE ORIENTABILI

	Codice	Descrizione	Taglio
$\left[\frac{(H-172.3)-2X}{60} \right] \times 2$	27366	LAMELLA 70 mm	L/2-161.3
2	SP K ..	Meccanismo di movimentazione	

LAMELLE ORIENTABILI

Nr Pezzi	Codice	Descrizione
2	SU K 95	Maniglia margherita

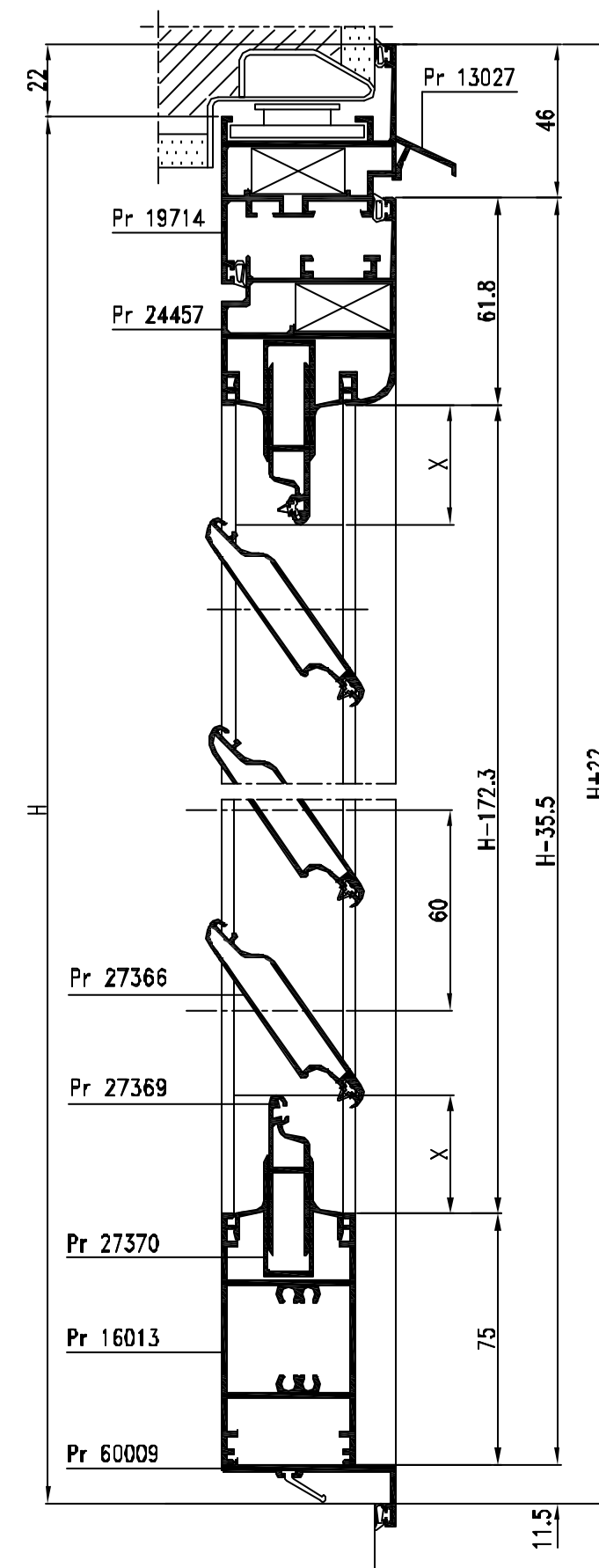
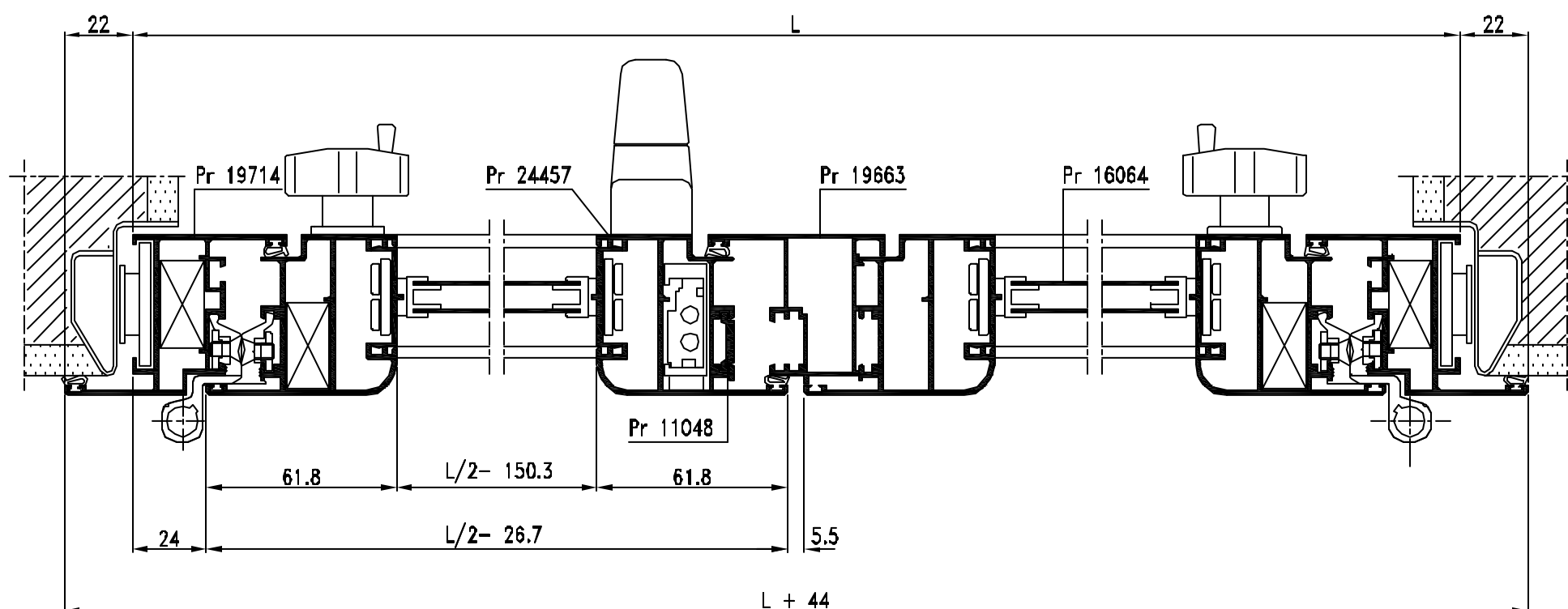



GELOSIA 1 ANTA

Abbinamento
DOMAL STOPPER PG

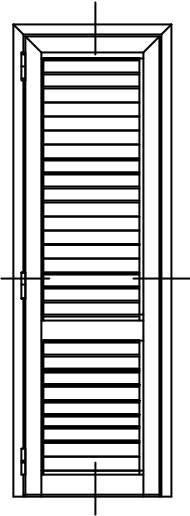

PROFILI

Nr Pezzi	Pr	Descrizione	Taglio
2	19714	Nontante telaio	HH22
1	19714	Traverso telaio	L+44
2	24457	Nontante anta	H-29
1	24457	Traverso anta	L-48
1	18013	Zoccolo-Fascia	L-131.8
1	13027	Gocciolatoio	L+44
1	11048	Asta di chiusura	[H]
2	27370	Porta lamella di compensazione	L-199.6
2	27369	Lamella di compensazione	L-192.8
1	28237	Profilito di finitura zoccolo	L-171.6

Pr 27366 lamella "PIANA" Pr 27367 lamella "GOCCIA" Pr 27368 lamella "RUSTICA"

GUARNIZIONI

Codice	Descrizione	Taglio
ST G 2B	Guarnizione per battuta	2L+H
SU G 01	Guarnizione per lamelle	Lx(n.lamelle+2)

FORMULA PER IL CALCOLO DELLA COMPENSAZIONE

$$X = \frac{\text{LAMELLE FISSE APERTE} \times \text{N}^{\circ} \text{ LAMELLE} \times 55 + 117 - \text{LUCE ANTA}}{2}$$

LAMELLE FISSE CHIUSE E LAMELLE ORIENTABILI

$$X = \frac{\text{LUCE ANTA} - \text{MISURA KIT}}{2}$$

ACCESSORI

Nr Pezzi	Codice	Descrizione
4	13 E 03	Espansore di regolazione
4	13 A 21	Squadretta in alluminio pressofuso
3	71 B 61	Cerniera reversibile terza anta
1	71 C 73	Cromanesse MAXIMA per aperture int./est. (dx)
1	13 C 15	Biacchetti di collegamento
1	71 D 20	Incontro per asta e terza chiusura
2	71 D 21	Terminale per asta di chiusura
1	80 D 17	Boccola
1	13 D 44	Tappe chiusi tubularità per Pr 24457
4	30 D 04	Tappe traverso Pr 16013

LAMELLE ORIENTABILI

	Codice	Descrizione	Taglio
$\frac{(H-h_{inf})-85.8}{80}$	27368	LAMELLA 70 mm	L-182.6
2	SP K ..	Mecanismo di movimentazione	

LAMELLE FISSE

	Codice	Descrizione	Taglio
$\frac{(H_{inf}-155)-2x}{80}$	27366	LAMELLA 70 mm	L-155.6

LAMELLE ORIENTABILI

Nr Pezzi	Codice	Descrizione
2	SU K 95	Margherita

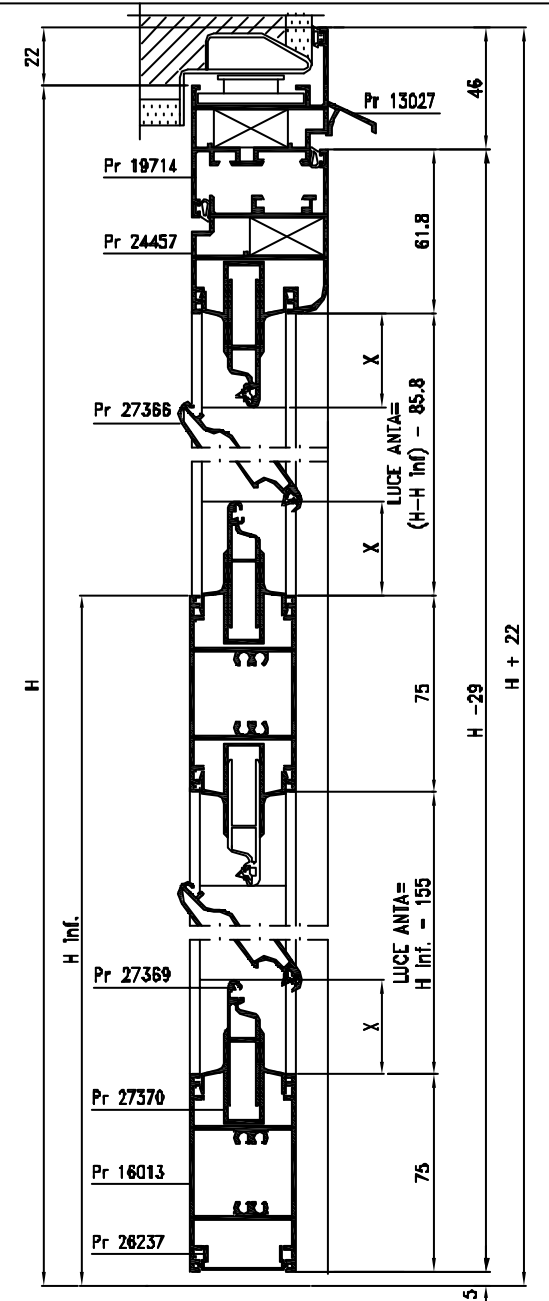
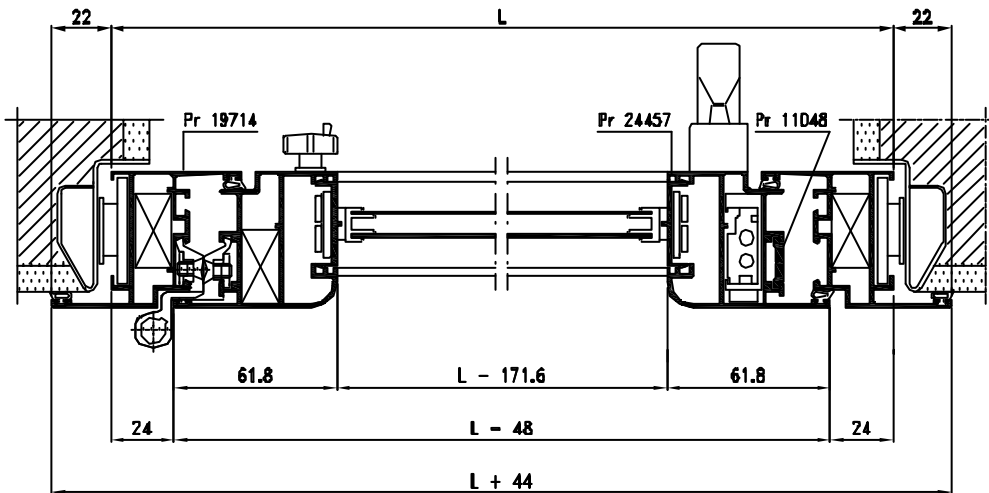



GELOSIA 2 ANTE Abbinamento DOMAL STOPPER PG

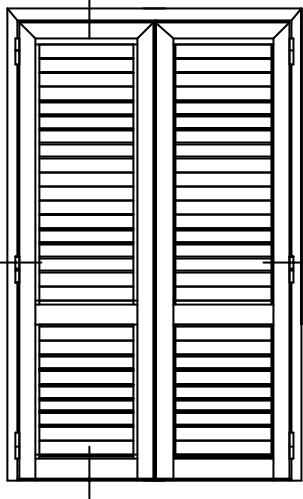

PROFILI

N° Pezzi	Pr	Descrizione	Taglio
2	19714	Montante telaio	H+22
1	19714	Traverso telaio	L+44
4	24457	Montante anta	H-29
2	24457	Traverso anta	L/2-26.7
1	19663	Riparto centrale	H-60
4	16013	Zoccolo-fascia	L/2-110.3
1	13027	Cocciolatoio	L+44
1	11048	Asta di chiusura	(H)
8	27370	Porta lamella di compensazione	L/2-178.3
8	27369	Lamella di compensazione	L/2-171.3
2	26237	Profilato di finitura zoccolo	L/2-150.3

Pr 27366 lamella "PIANA" Pr 27367 lamella "GACCIA" Pr 27368 lamella "RUSTICA"

GUARNIZIONI

Codice	Descrizione	Taglio
ST G 29	Guarnizione per battuta	2L+6H
SU C 01	Guarnizione per lamelle	L/2x(n.lamelle+4)

FORMULA PER IL CALCOLO DELLA COMPENSAZIONE

LAMELLE FISSE APERTE	
$X = \frac{N^{\circ} \text{ LAMELLE} \times 95 + 117 - \text{LUCE ANTA}}{2}$	
LAMELLE FISSE CHIUSE E LAMELLE ORIENTABILI	
$X = \frac{\text{LUCE ANTA} - \text{MISURA KIT}}{2}$	

ACCESSORI

N° Pezzi	Codice	Descrizione
6	13 E 03	Espansore di regolazione
6	13 A 21	Squadrette in alluminio pressofuso
1	13 D 31	Tappo per profilo di riparto Pr 19663
6	71 B 61	Carniera reversibile terza anta
1	71 C 73	Cremone MAXIMA per aperture int/est. (dx)
1	13 C 15	Bloccchetti di collegamento
1	71 D 20	Incontro per asta e terza chiusura
2	71 D 21	Terminale per asta di chiusura
1	60 D 17	Boccola
2	13 D 44	Tappo chiudi tubolarita per Pr 24457
1	13 D 22	Tappo chiudi tubolarita per Pr 19663
8	30 D 04	Tappo traverso Pr 16013

LAMELLE ORIENTABILI

	Codice	Descrizione	Taglio
$\left[\frac{H - \text{Inf.}}{60} - 85.5 \right] \times 2$	27386	LAMELLA 70 mm	L/2-161.3
2	SP K ..	Meccanismo di movimentazione	

LAMELLE FISSE

	Codice	Descrizione	Taglio
$\left[\frac{H - \text{Inf.} - 155}{60} - 2x \right] \times 2$	27366	LAMELLA 70 mm	L/2-134.3
2	SP K ..	Meccanismo di movimentazione	

LAMELLE ORIENTABILI

Nr Pezzi	Codice	Descrizione
4	SU K 95	Maniglia margherita

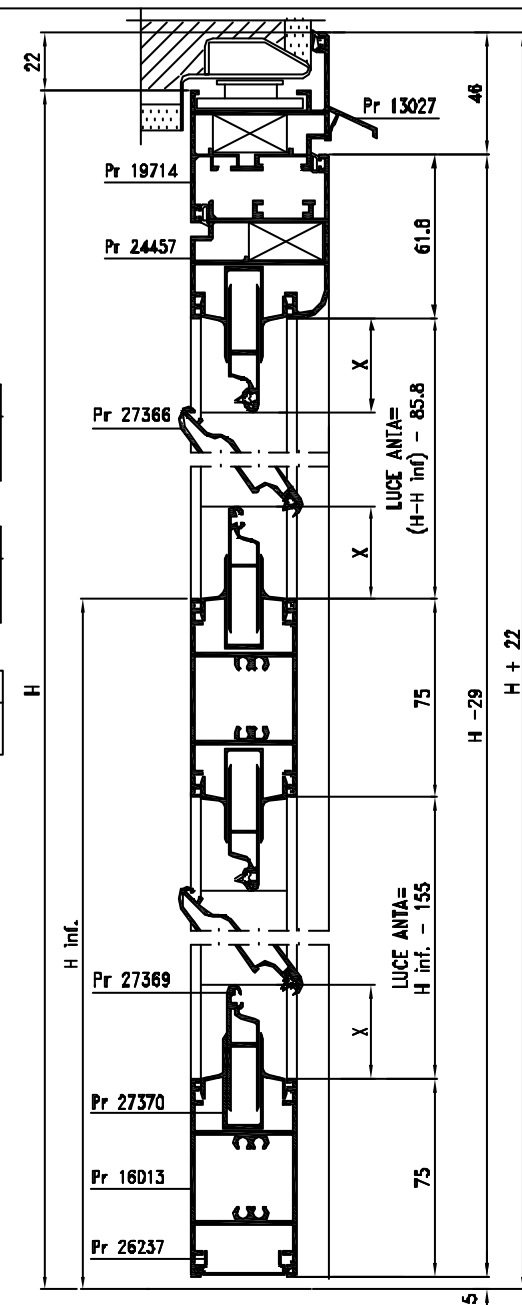
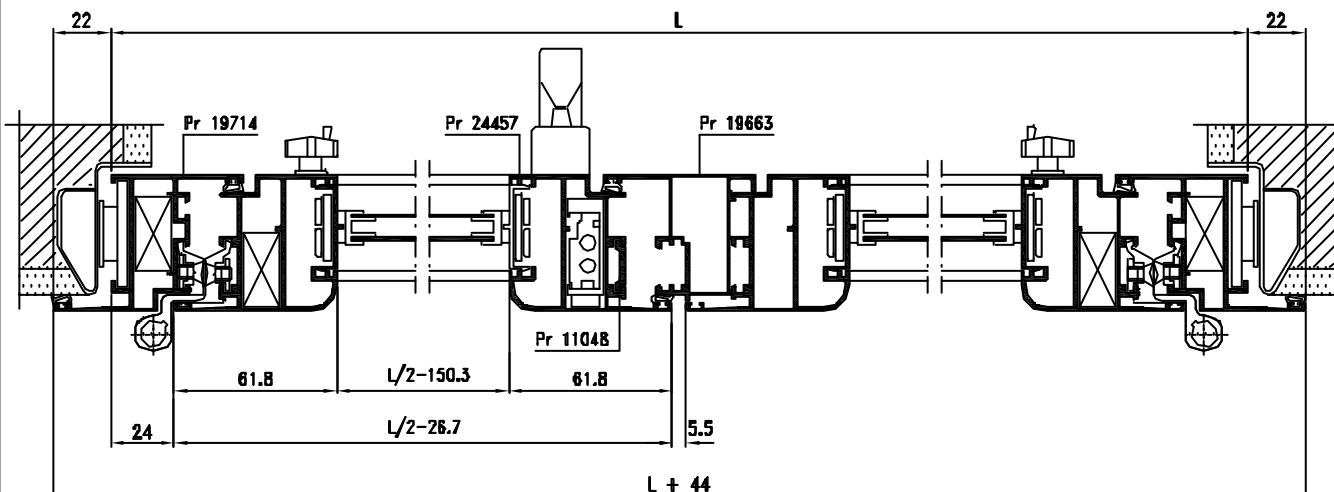



GELOSIA 2 ANTE Abbinamento DOMAL 40

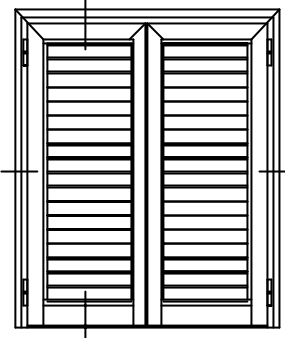

PROFILI

Nr Pezzi	Pr	Descrizione	Taglio
2	19750	Montante telaio	H-22
1	19750	Traverso telaio	L+44
1	13027	Gucciatelaio	L+44
3	19724	Montante anta	H-19,8
1	19723	Montante anta	H-11,8
2	19724	Traverso anta	L/2-8,5
2	16013	Zoccolo	L/2-79,9
1	19730	Asta di chiusura	(H)
4	27370	Parte lamella di compensazione	L/2-147,9
4	27369	Lamella di compensazione	L/2-140,9
2	26237	Profilato di finitura zoccolo	L/2-119,9

Pr 27368 lamella "PIANA" Pr 27367 lamella "GOCCIA" Pr 27368 lamella "RUSTICA"

GUARNIZIONI

Codice	Descrizione	Taglio
90 G 31	Guarnizione per battuta	2L+8H
SU G 01	Guarnizione per lamelle	L/2x(n.lamelle+1)

FORMULA PER IL CALCOLO DELLA COMPENSAZIONE

LAMELLE FISSE APERTE	
$X = \frac{N^{\circ} \text{ LAMELLE} \times 55 + 117 - \text{LUCE ANTA}}{2}$	
LAMELLE FISSE CHIUSE E LAMELLE ORIENTABILI	
$X = \frac{\text{LUCE ANTA} - \text{MISURA KIT}}{2}$	

ACCESSORI

Nr Pezzi	Codice	Descrizione
8	40 E 03	Espansore di regolazione
6	04 A 21	Squadretta in alluminio pressofuso
4	84 B 10	Cerniera reversibile
1	71 C 73	Cremonese MAXIMA per aperture int./est. (dx)
1confaz.	40 C 02	Blazzetta guida aste
1	64 D 3L	Intantra per asta
2	64 D 2L	Terminale per asta di chiusura
1	80 D 17	Boccola
1pezzo	40 D 07	Tappi chiudi battuta
2	40 C 03	Perni collegamento
2	30 D 27	Tappo chiudi tubolarità x Pr 19724

LAMELLE ORIENTABILI

	Codice	Descrizione	Taglio
$\left[\begin{matrix} (H-150,6)-2x \\ 60 \end{matrix} \right] \times 2$	27366	LAMELLA 70 mm	L/2-130,9
2	SP K L	Meccanismo di movimentazione	

LAMELLE ORIENTABILI

Nr Pezzi	Codice	Descrizione
2	SU K 95	Maniglia margherita

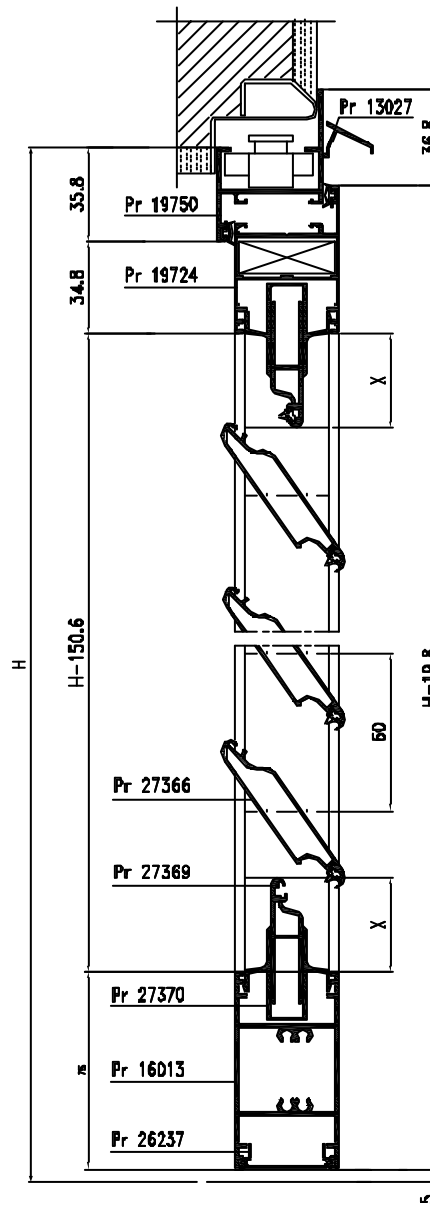
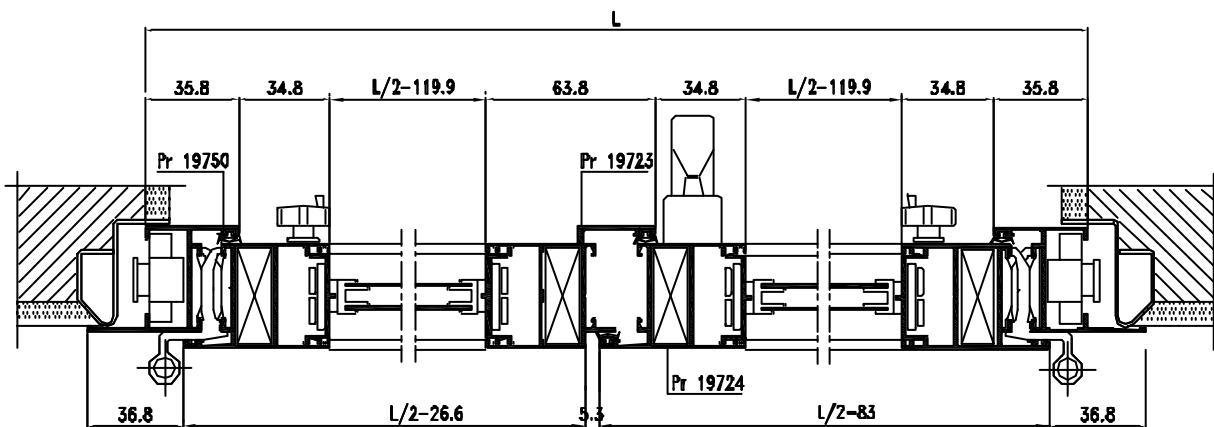



GELOSIA 1 ANTA SCORREVOLE

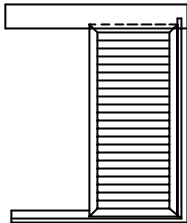

PROFILI

N° Pezzi	Pr	Descrizione	Taglio
1	18074	Guida superiore	$LB=2L+40$
1	16073	Cartella per guida superiore	$LB=2L+40$
1	16075	Guida inferiore	$LB=2L+40$
1	16075	Montante telaio	$H2=H+40$
2	18085	Montante anta	$HA=H$
2	16065	Traversa sup. ed inf. anta	$LA=L+30$
1	18077	Riparto di tenuta superiore	$LA+1.8$
1	16077	Riparto di tenuta laterale	$HA+1.8$
2	19847	Traversa di contenimento lamella	$L1=LA-96.4$
2	13189	Lamella di compensazione	$L1+3$
$\frac{H1-2X}{40}$	13199	Lamella fissa 65 mm a 30°	$L1-5$

GUARNIZIONI

Codice	Descrizione	Taglio
9D S 02	Spazzolino di tenuta perimetrale anta e telaio	$2LB+3L+4HA$

ACCESSORI

N° Pezzi	Codice	Descrizione
4	13 A 21	Squadretta in alluminio pressofuso
4	30 D 23	Compensatore di dilatazione in nylon nero
$\frac{H1-2X}{40}$	30 D 21	Coppia tappi in nylon nero per lamella fissa 30°
1	13 D 66	Catenaccio in alluminio per arresto anta oscurata
2	30 R 10	Fermo arresto per anta scorrevole
2	30 R 11	Guida a rullo inferiore in fibra nera
2	30 R 12	Carrello con cuscinetto per anta scorrevole
1	30 D 30	Coppia tappi laterali per chiusura cartella sup.
1	GE 005	Tappo di chiusura tubularità per Pr 16075

X = MIN. 20 mm
X = MAX. 40 mm

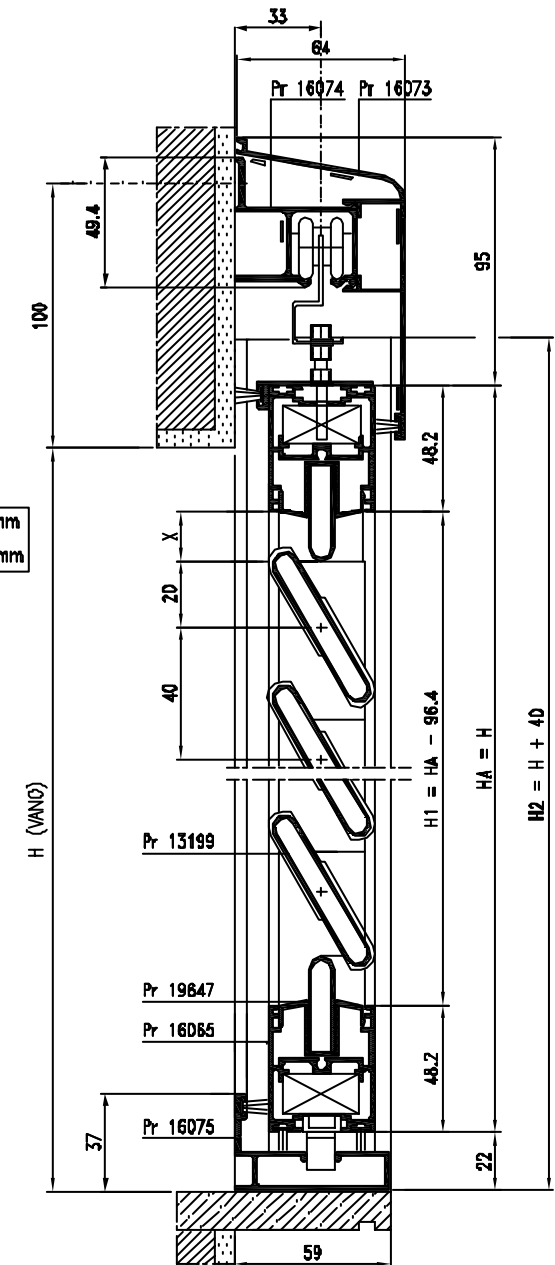
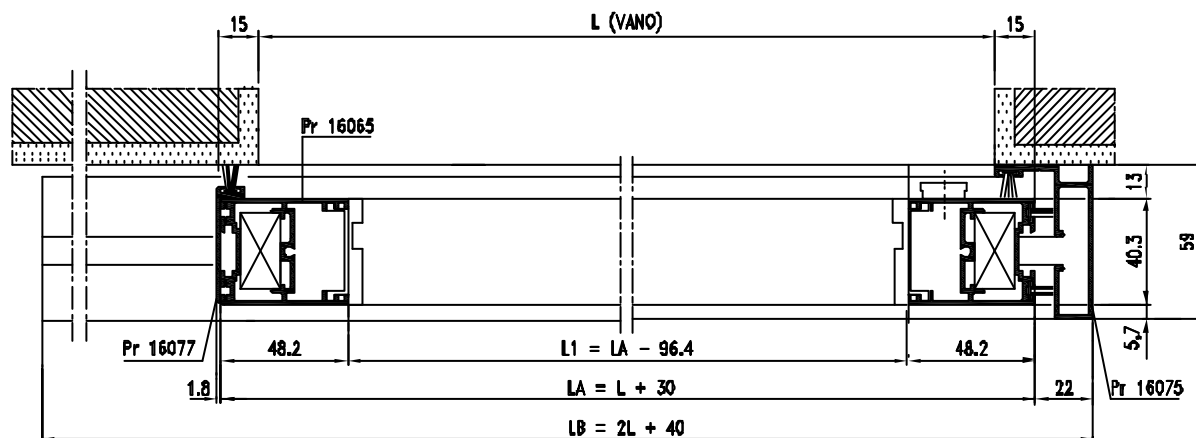

GELOSIA 2 ANTE SCORREVOLE

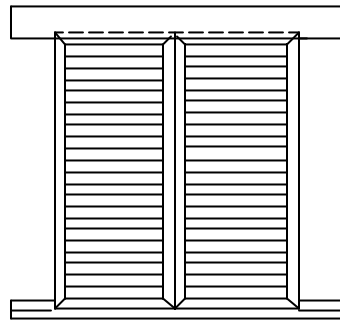

PROFILI

№ Pezzi	Pr	Descrizione	Taglio
1	16074	Guida superiore	$LB=2L-50$
1	16073	Cartella per guida superiore	$LB=2L-50$
1	16075	Guida inferiore	$LB=2L-50$
4	16065	Montante anta	$HA=H$
4	16065	Traversa superiore ed inferiore anta	$LA=L/2+13$
2	16077	Riparto di tenuta superiore	$LA+1.8$
2	16077	Riparto di tenuta laterale	$HA+1.8$
1	19637	Riparto di tenuta centrale	$HA-23$
4	19647	Traversa di contenimento lamella	$L1=LA-96.4$
4	13199	Lamella di compensazione	$L1+3$
$\frac{H1-2X}{40} \times 2$	13199	Lamella fissa 65 mm a 30°	$L1-5$

ACCESSORI

№ Pezzi	Codice	Descrizione
8	13 A 21	Squadretta in alluminio pressafuso
8	30 D 23	Compensatore di dilatazione in nylon nero
$\frac{H1-2X}{40} \times 2$	30 D 21	Coppia tappi in nylon nero per lamella fissa 30°
1	30 M 01	Maniglia di chiusura con gancia e riscontro
1	13 D 66	Catenaccio in alluminio per arresto anta dx.nero
4	30 R 10	Fermo per arresto anta scorrevole
4	30 R 11	Guida a rullo inferiore in fibra nera
4	30 R 12	Carrello con cuscinetto per anta scorrevole
1	30 D 30	Coppia tappi laterali per chiusura cartella sup.
1	GE 005	Tappo di chiusura tubolarità per Pr 16075

GUARNIZIONI

Codice	Descrizione	Taglia
90 S 52	Spazzolino di tenuta centrale anta	2HA
90 S 62	Spazzolino di tenuta perimetrale anta e telaio	2LB+3L+2HA

X = MIN. 20 mm
X = MAX. 40 mm

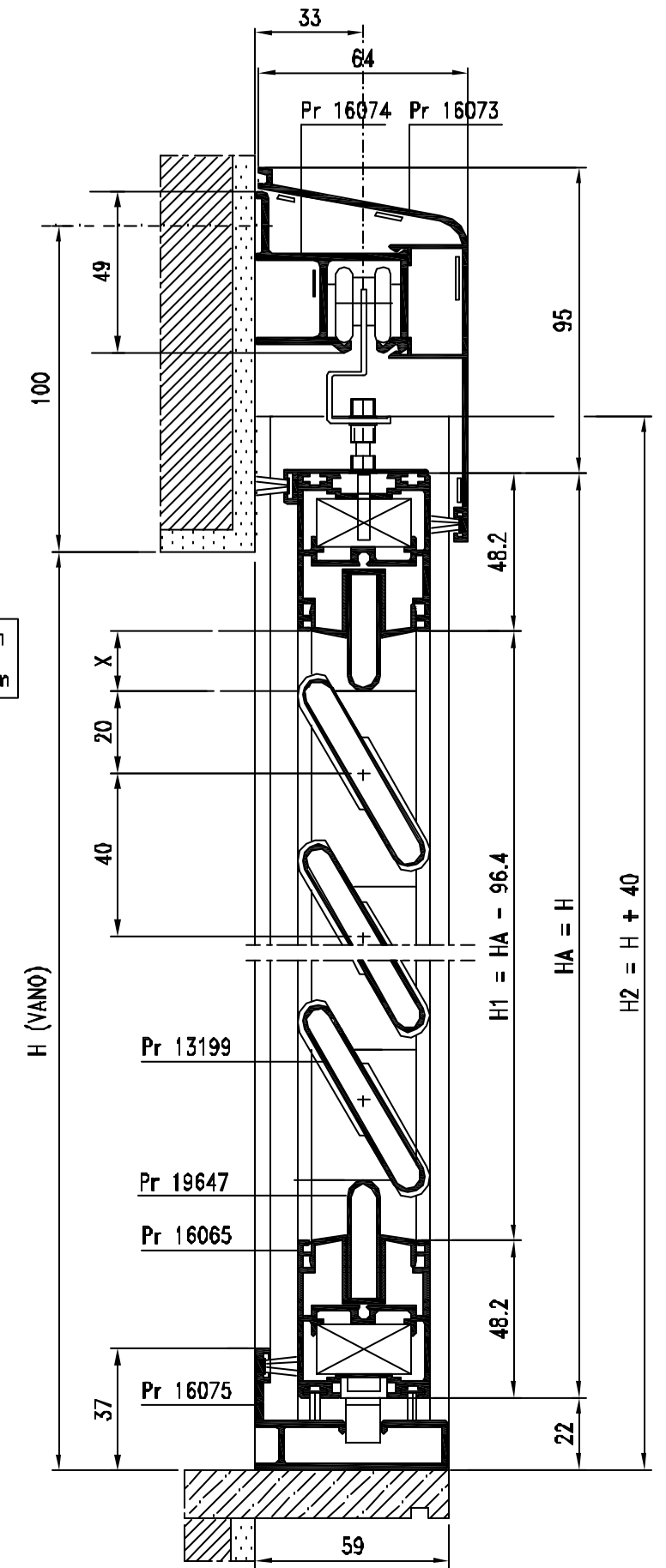
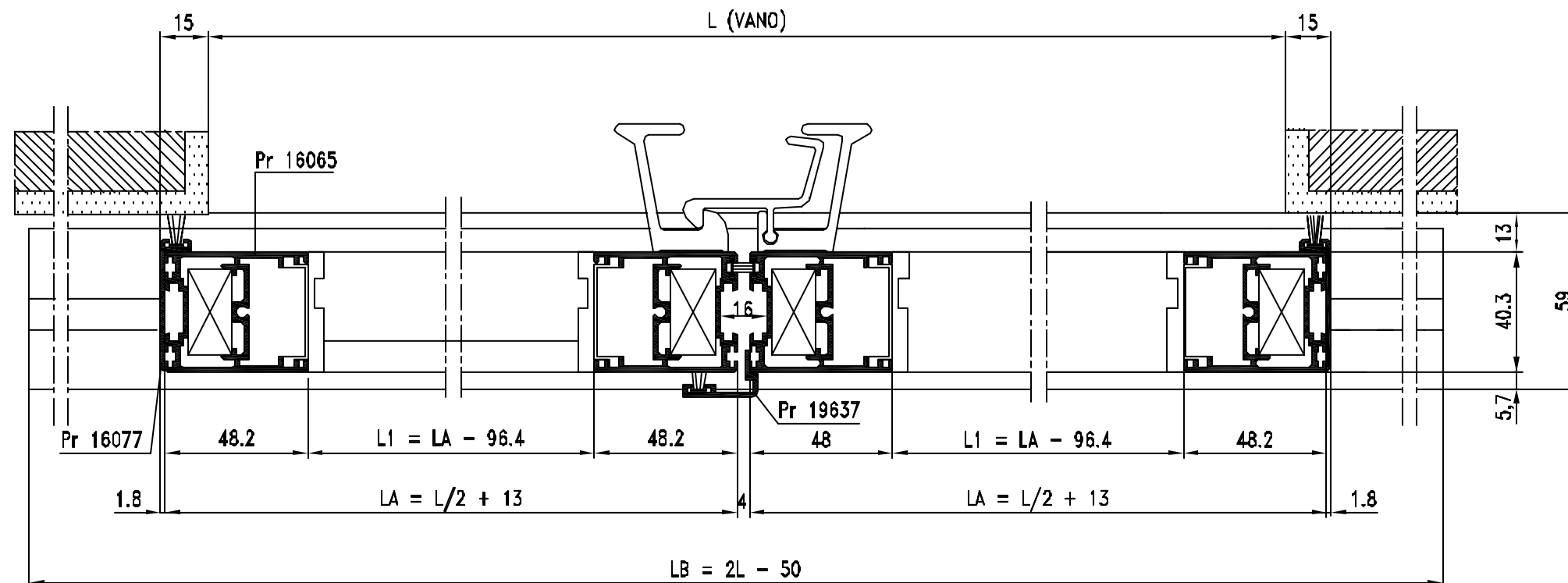

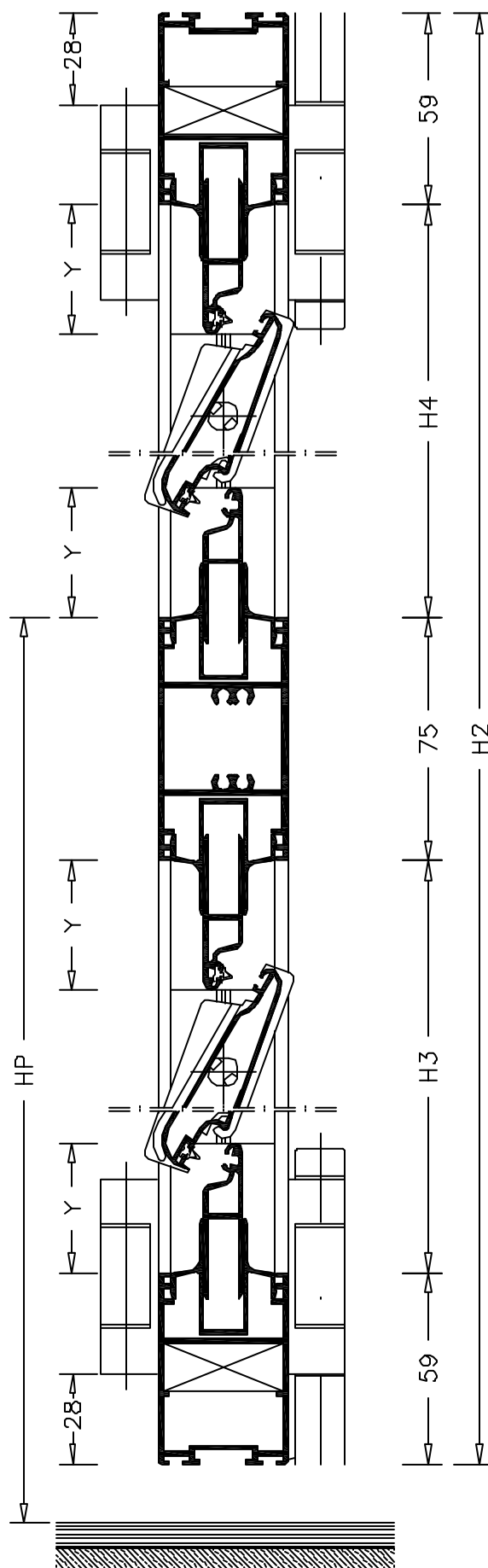

SEZIONE VERTICALE VARIANTE - CON TRAVERSO

PROFILATI (Guida Incassata)

N° Pezzi	Pr	Descrizione	Misura	Taglio
1	19643	Guida superiore	L	90°-90°
1	19634	Guida inferiore	L	90°-90°
2	20373	Montanti telaio	H-80	90°-90°
2N	19640	Traversi ante	[(L-86)/N]-10	45°-45°
2N	19640	Montanti ante	H-107	45°-45°
1	19637	Riparto battuta	H-107	90°-90°
N	16013	Fascia	[(L-86)/N]-128	90°-90°
N	19632	Sottozoccolo	(L-86)/N	90°-90°
4N	27369	Lamella di comp.	[(L-86)/N]-129	90°-90°
4N	27370	Parte lamella di comp.	[(L-86)/N]-128	90°-90°
1	*	Compensatore	(L+2X)	90°-90°
2	*	Compensatore	(H+X)-52	90°-90°

* : Scegliere tra Pr. 14129 oppure Pr. 19633 + Pr. 13081

SEZIONE VERTICALE VARIANTE - CON TRAVERSO

PROFILATI (Guida Normale)

N° Pezzi	Pr	Descrizione	Misura	Taglio
1	19643	Guida superiore	L	90°-90°
1	20373	Guida inferiore	L	45°-45°
2	20373	Montanti telaio	H1-59.5	45°-90° 1Dx-1Sx
2N	19640	Traversi ante	[(L-86)/N]-10	45°-45°
2N	19640	Montanti ante	H-107	45°-45°
1	19637	Riparto battuta	H-107	90°-90°
N	16013	Fascia	[(L-86)/N]-128	90°-90°
4N	27369	Lamella di comp.	[(L-86)/N]-129	90°-90°
4N	27370	Parte lamella di comp.	[(L-86)/N]-128	90°-90°
1	*	Compensatore	(L+2X)	90°-90°
2	*	Compensatore	(H1+X)-35	90°-90°

* : Scegliere tra Pr. 14129 oppure Pr. 19633 + Pr. 13081

FORMULA PER IL CALCOLO DELLA COMPENSAZIONE

LAMELLE FISSE APERTE	LAMELLE FISE CHIUSE E LAMELLE ORIENTABILI
$Y = \frac{N^{\circ} \text{ LAMELLE} \times 55 + 117 - \text{LUCE ANTA}}{2}$	$Y = \frac{\text{LUCE ANTA} - \text{MISURA KIT}}{2}$

ACCESSORI (Guida Incassata)

N° Pezzi	Codice	Descrizione
4N	04 A 21	Squadretta a scatto
4	04 E 21	Cavallotto
2	30 E 21	Plastrina per cavallotto
N + 2	30 E 01	Regolo per guida superiore
6	30 E 02	Regolo per telaio
(N-1)/2	30 R 01	Carrello e pattino con cerniera intera
2N + 1	30 B 05	Cerniera a contrasto
(N-1)/2	30 D 15	Catenacciolo a doppio effetto
N + 1	30 D 10	Terminale per aste di chiusura
(N-1)/2	30 M 16	Maniglia a vaschetta
1	71 C 73	Cremonese "MAXIMA"
4	30 D 03	Pattino per asta Pr. 11048
2N	30 D 04	Tappo per fascia PR 16013

ACCESSORI (Guida Normale)

N° Pezzi	Codice	Descrizione
4N+2	04 A 21	Squadretta a scallo
4	04 E 21	Cavallotto
2	30 E 21	Plastrina per cavallotto
N + 2	30 E 01	Regolo per guida superiore
6	30 E 02	Regolo per telaio
(N-1)/2	30 R 01	Carrello e pattino con cerniera intera
2N + 1	30 B 05	Cerniera a contrasto
(N-1)/2	30 D 15	Catenacciolo a doppio effetto
N + 1	30 D 10	Terminale per aste di chiusura
(N-1)/2	30 M 16	Maniglia a vaschetta
1	71 C 73	Cremonese "MAXIMA"
4	30 D 03	Pattino per asta Pr. 11048
2N	30 D 04	Tappo per fascia PR 16013

FORMULA PER IL CALCOLO DEL NUMERO DELLE LAMELLE + ACCESSORI

LAMELLE ORIENTABILI E FISSE CHIUSE

N° Pezzi	Codice	Descrizione	Taglio
$\frac{H3-2Y}{60} \times N$	27367	Lamella 70 mm	
2N	SP K...	Meccanismo di movimentazione	
*2N	SU K 97	Maniglia margherita estraibile	

Utilizzare la stessa formula per H4
 PR 27366 lamella "PIANA" PR 27367 lamella "GOCCIA" PR 27368 lamella "RUSTICA"
 * Solo per orientabili

LAMELLE FISSE APERTE

N° Pezzi	Codice	Descrizione	Taglio
$\frac{H3-2Y}{55} \times N$	27367	Lamella 70 mm	
2x N°Lamelle	S.....10	Selle ambidestra	
2N	S.....01	Compensatori (coppie)	

Utilizzare la stessa formula per H4
 PR 27366 lamella "PIANA" PR 27367 lamella "GOCCIA" PR 27368 lamella "RUSTICA"
 Selle SGD 10 per lamella a "GOCCIA" e "RUSTICA"; SPD 10 per lamella "PIANA"
 Compensatori SGD 01 per selle SGD 10; SPD 01 per selle SPD 10

LA SEZIONE ORIZZONTALE E' A PAG. C 14

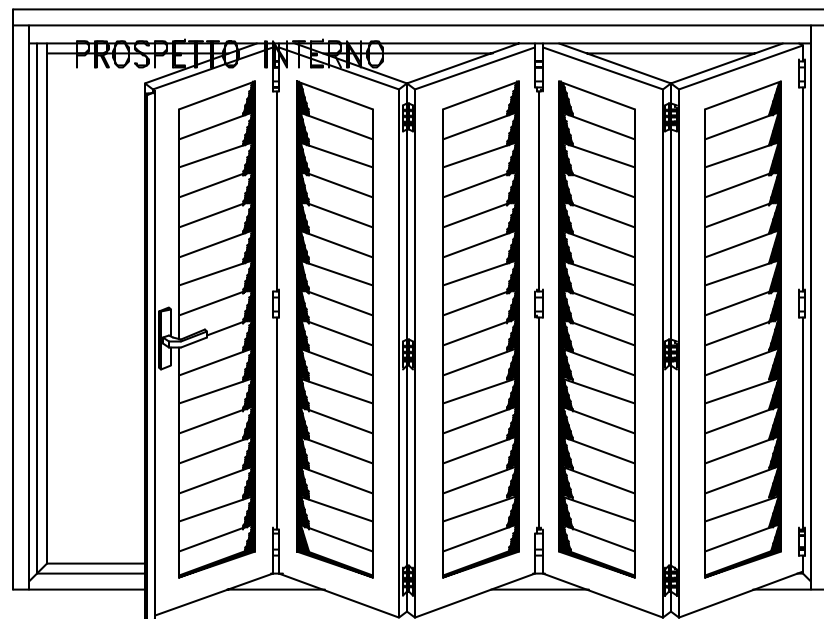

PER GLI ACCESSORI DI MOVIMENTAZIONE FARE RIFERIMENTO AL CATALOGO DOMAL GARDEN

LA SEZIONE VERTICALE E' A PAG. C 13

SEZIONE ORIZZONTALE

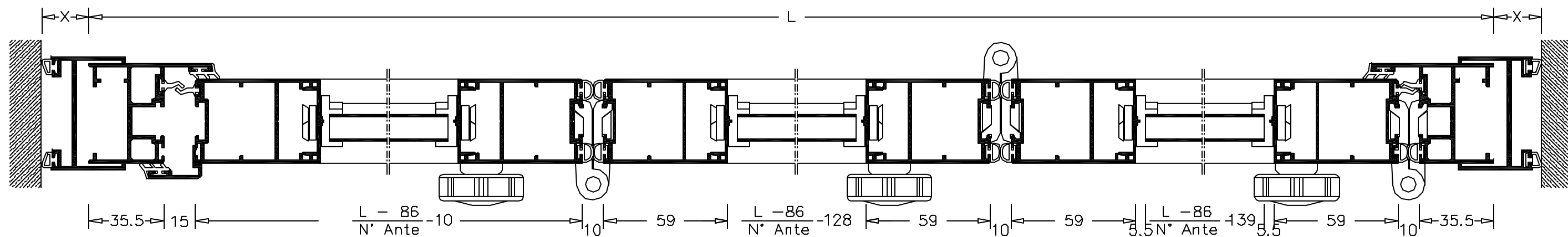

GELOSIA 2 ANTE Abbinamento DOMAL STOPPER PG

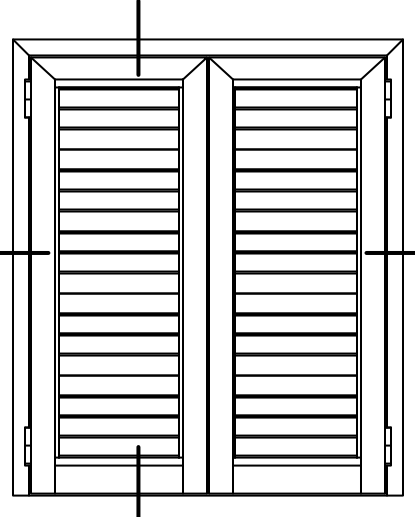

PROFILI

Nr Pezzi	Pr	Descrizione	Taglio
2	27330	Montante telaio	H+25
1	27330	Traverso telaio	L+50
4	27329	Montante anta	H-29
2	27329	Traverso anta	L/2-26.8
1	19663	Riparto centrale	H-60
2	16012	Zoccolo	L/2-176.8
1	11048	Asta di chiusura	(H)
4	27370	Porta lamella di compensazione	L/2-204.8
4	27369	Lamella di compensazione	L/2-197.8
2	26237	Profilato di finitura zoccolo	L/2-176.8

GUARNIZIONI

Codice	Descrizione	Taglio
ST G 29	Guarnizione per battuta	3L+8H
SU G 01	Guarnizione per lamelle	L/2x(n.lamelle+1)

FORMULA PER IL CALCOLO DELLA COMPENSAZIONE

<p>LAMELLE FISSE APERTE</p> $x = \frac{N^{\circ} \text{ LAMELLE} \times 55 + 117 - \text{LUCE ANTA}}{2}$
<p>LAMELLE FISSE CHIUSE E LAMELLE ORIENTABILI</p> $x = \frac{\text{LUCE ANTA} - \text{MISURA KIT}}{2}$

ACCESSORI

Nr Pezzi	Codice	Descrizione
8	13 E 03	Espansore di regolazione
6	13 A 21	Squadretta in alluminio pressofuso
1	13 D 31	Tappo per profilato di riparto Pr 19663
4	71 B 61	Cerniera reversibile terza anta
1	71 C 73	Cremonese
1	13 G 100	Blocchetto guida aste
1	71 D 20	Incontro per asta
2	71 D 21	Terminale per asta di chiusura
1	80 D 17	Bussola pavimento
4	13 D 100	Tappo chiudi tubolarita' per Pr 27329
1	13 D 22	Tappo chiudi tubolarita' per Pr 19663
4	30 D 05	Tappo traverso Pr 16012

LAMELLE ORIENTABILI

	Codice	Descrizione	Taglio
$\left[\frac{(H-204)-2X}{60} \right] \times 2$	27367	LAMELLA 70 mm	L/2-187.8
2	SG K ..	Meccanismo di movimentazione	

Nr Pezzi	Codice	Descrizione
2	SU K 96	Maniglia margherita

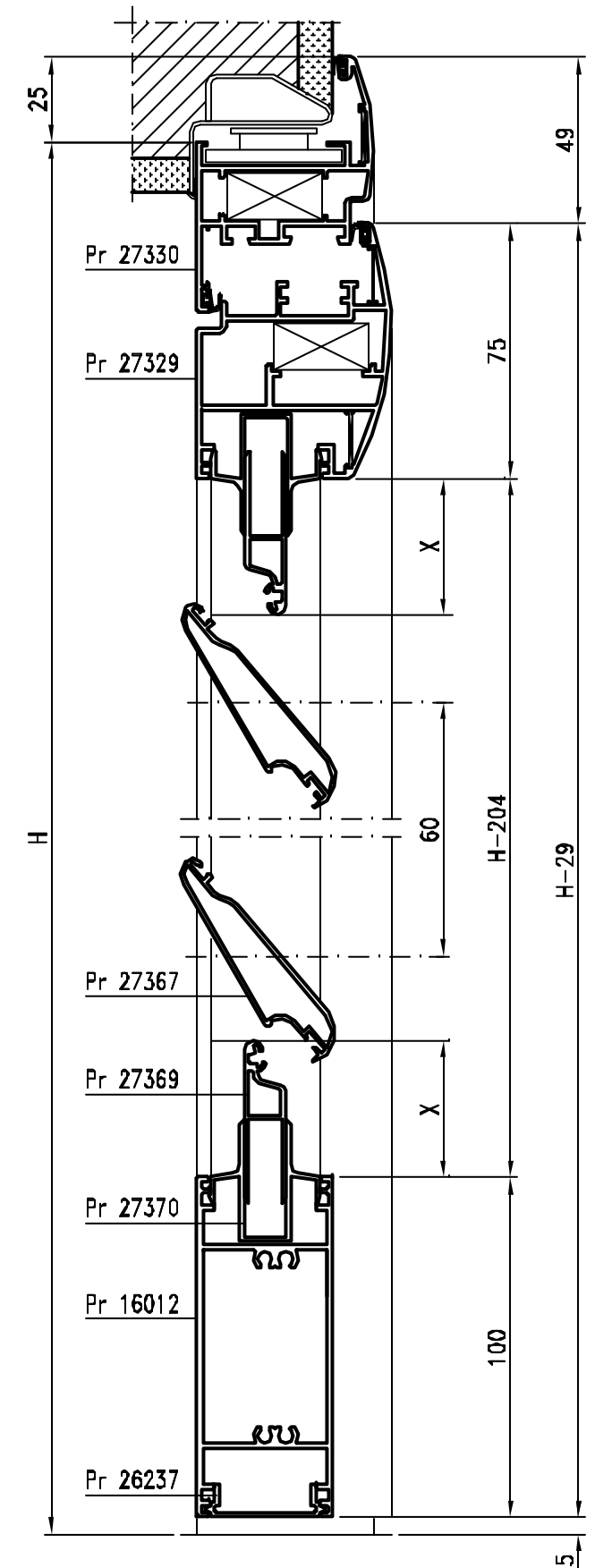
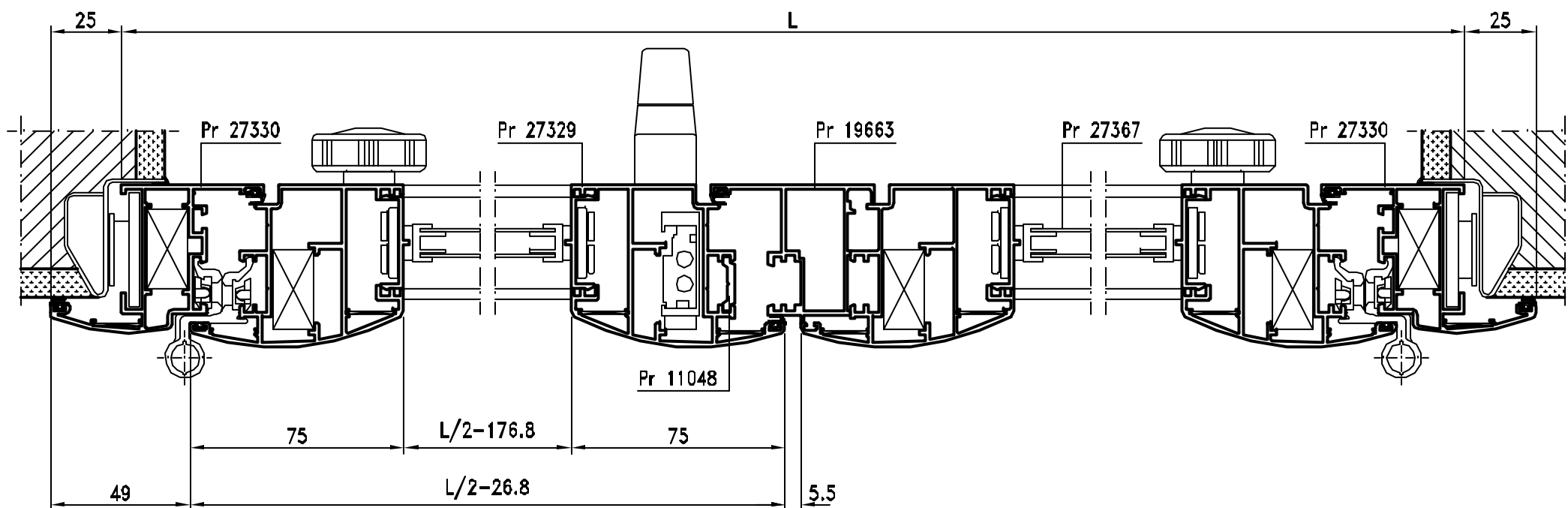

GELOSIA 3 ANTE Abbinamento DOMAL STOPPER PG

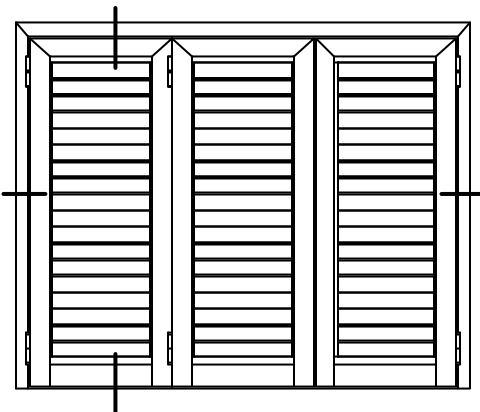

PROFILI

Nr Pezzi	Pr	Descrizione	Taglio
2	27330	Montante telaio	H+25
1	27330	Traverso telaio	L+50
6	27329	Montante anta	H-29
3	27329	Traverso anta	L/3-19.7
2	19663	Riporta centrale	H-60
3	16012	Zoccolo	L/3-169.7
1	11048	Asta di chiusura	(H)
6	27370	Porta lamella di compensazione	L/3-197.7
6	27369	Lamella di compensazione	L/3-190.7
3	26237	Profilato di finitura zoccolo	L/3-169.7

GUARNIZIONI

Codice	Descrizione	Taglio
ST G 29	Guarnizione per battuta	3L+10H
SU G 01	Guarnizione per lamella	L/3x(n.lamelle+1)

FORMULA PER IL CALCOLO DELLA COMPENSAZIONE

<p>LAMELLE FISSE APERTE</p> $X = \frac{N \text{ LAMELLE} \times 55 + 117 - \text{LUCE ANTA}}{2}$
<p>LAMELLE FISSE CHIUSE E LAMELLE ORIENTABILI</p> $X = \frac{\text{LUCE ANTA} - \text{MISURA KIT}}{2}$

ACCESSORI

Nr Pezzi	Codice	Descrizione
8	13 E 03	Espansore di regolazione
8	13 A 21	Squadretta in alluminio pressofuso
2	13 D 31	Tappo per profilato di riparto Pr 19663
6	71 B 61	Cerniera reversibile terza anta
1	71 C 73	Cremonese
1	13 C 100	Bloccetto guida aste
2	71 D 20	Incontro per asta
2	71 D 21	Terminale per asta di chiusura
2	80 D 17	Bussola pavimento
6	13 D 100	Tappo chiudi tubalarita' per Pr 27329
2	13 D 22	Tappo chiudi tubalarita' per Pr 19663
1	71 D 30	Catenaccio
1	71 D 27	Tappo sostenimento anta
6	30 D 05	Tappo traverso Pr 16012

LAMELLE ORIENTABILI

	Codice	Descrizione	Taglio
$\left[\frac{(H-204)-2X}{60} \right] \times 3$	27367	LAMELLA 70 mm	L/3-180.7
3	SG K ..	Meccanismo di movimentazione	

Nr Pezzi	Codice	Descrizione
2	SU K 96	Maniglia margherita

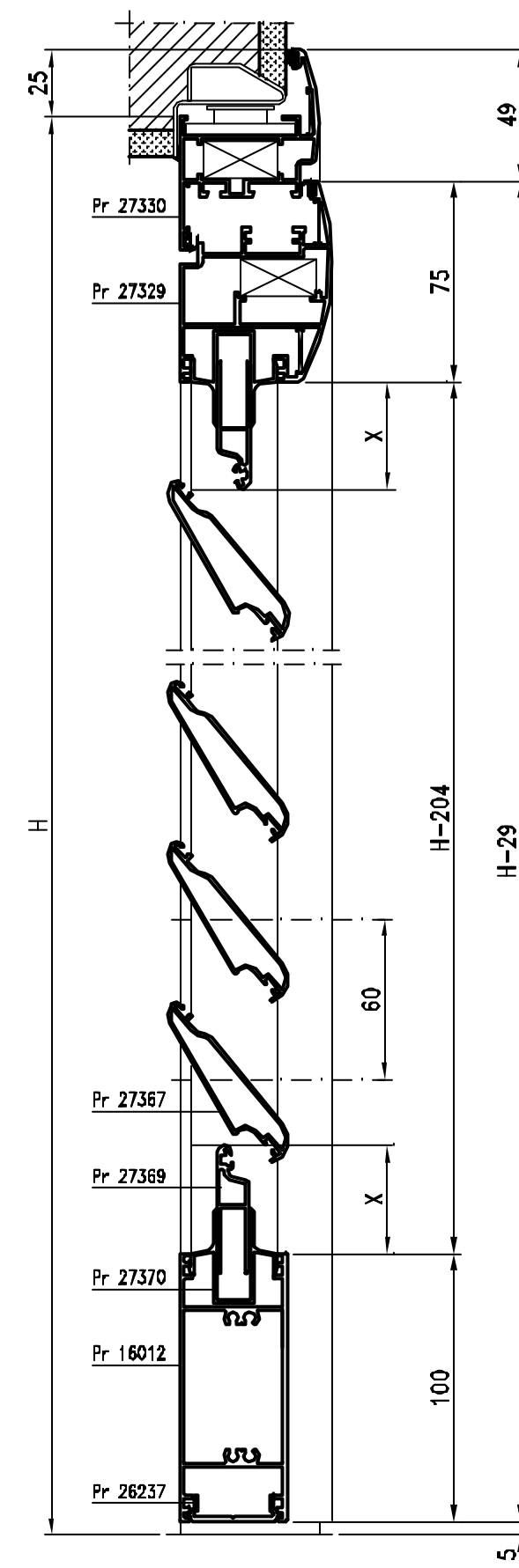
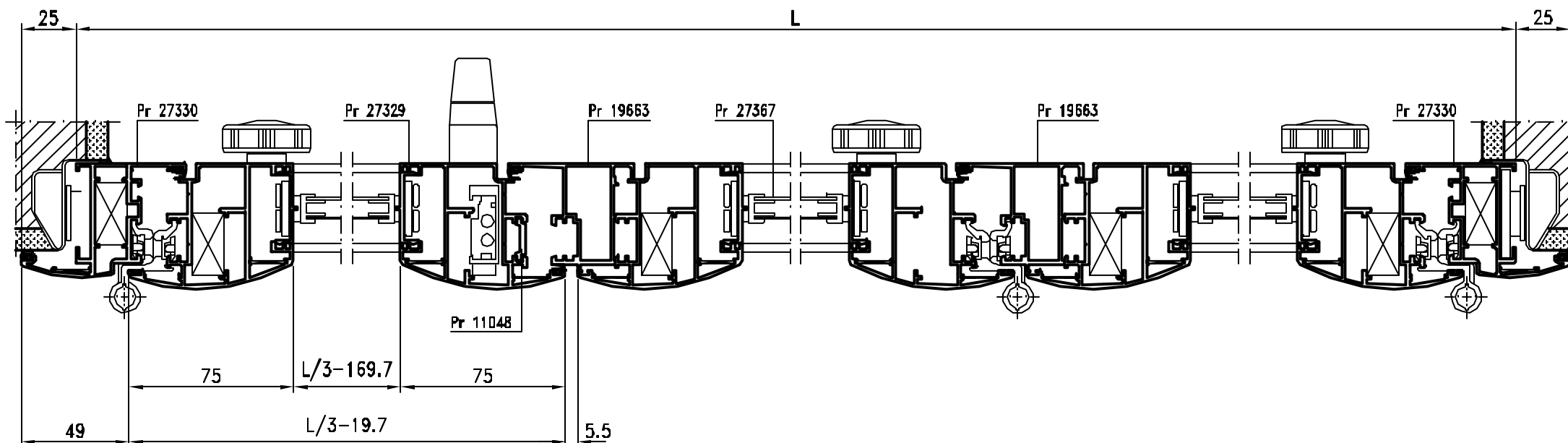

GELOSIA 2 ANTE Abbinamento DOMAL STOPPER PG

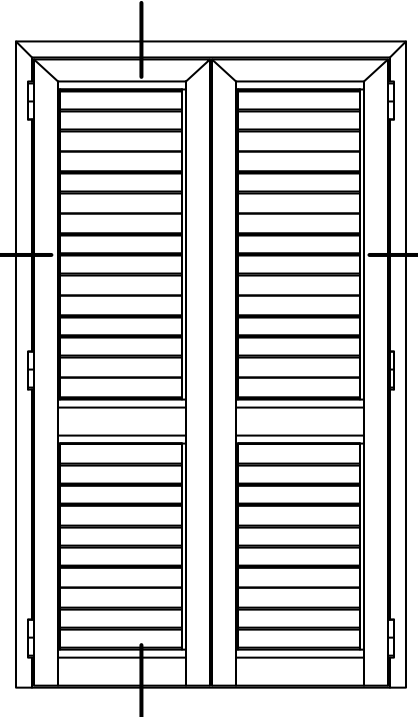

PROFILI

Nr Pezzi	Pr	Descrizione	Taglio
2	27330	Montante telaio	H+25
1	27330	Traverso telaio	L+50
4	27329	Montante anta	H-29
2	27329	Traverso anta	L/2-26.8
1	19663	Riparto centrale	H-60
4	16012	Zoccolo	L/2-176.8
1	11048	Asta di chiusura	(H)
8	27370	Porta lamella di compensazione	L/2-204.8
8	27369	Lamella di compensazione	L/2-197.8
2	26237	Profilato di finitura zoccolo	L/2-176.8

GUARNIZIONI

Codice	Descrizione	Taglio
ST G 29	Guarnizione per battuta	3L+8H
SU G 01	Guarnizione per lamelle	L/2x(n.lamelle+1)

FORMULA PER IL CALCOLO DELLA COMPENSAZIONE

<p>LAMELLE FISSE APERTE</p> $x = \frac{N^{\circ} \text{ LAMELLE} \times 55 + 117 - \text{LUCE ANTA}}{2}$
<p>LAMELLE FISSE CHIUSE E LAMELLE ORIENTABILI</p> $x = \frac{\text{LUCE ANTA} - \text{MISURA KIT}}{2}$

ACCESSORI

Nr Pezzi	Codice	Descrizione
8	13 E 03	Espansore di regolazione
6	13 A 21	Squadretta in alluminio pressofuso
1	13 D 31	Tappo per profilato di riparto Pr 19663
6	71 B 61	Cerniera reversibile terza anta
1	71 C 73	Cremonese
1	13 G 100	Blocchetto guida aste
1	71 D 20	Incontro per asta
2	71 D 21	Terminale per asta di chiusura
1	80 D 17	Bussola pavimento
4	13 D 100	Tappo chiudi tubolarita' per Pr 27329
1	13 D 22	Tappo chiudi tubolarita' per Pr 19663
8	30 D 05	Tappo traverso Pr 16012

LAMELLE ORIENTABILI

	Codice	Descrizione	Taglio
$\left[\frac{(H-H \text{ inf.})-99-2X}{60} \right] \times 2$	27367	LAMELLA 70 mm	L/2-187.8
$\left[\frac{(H \text{ inf.}-205)-2X}{60} \right] \times 2$	27367	LAMELLA 70 mm	L/2-187.8
4	SG K ..	Meccanismo di movimentazione	

Nr Pezzi	Codice	Descrizione
4	SU K 96	Maniglia margherita

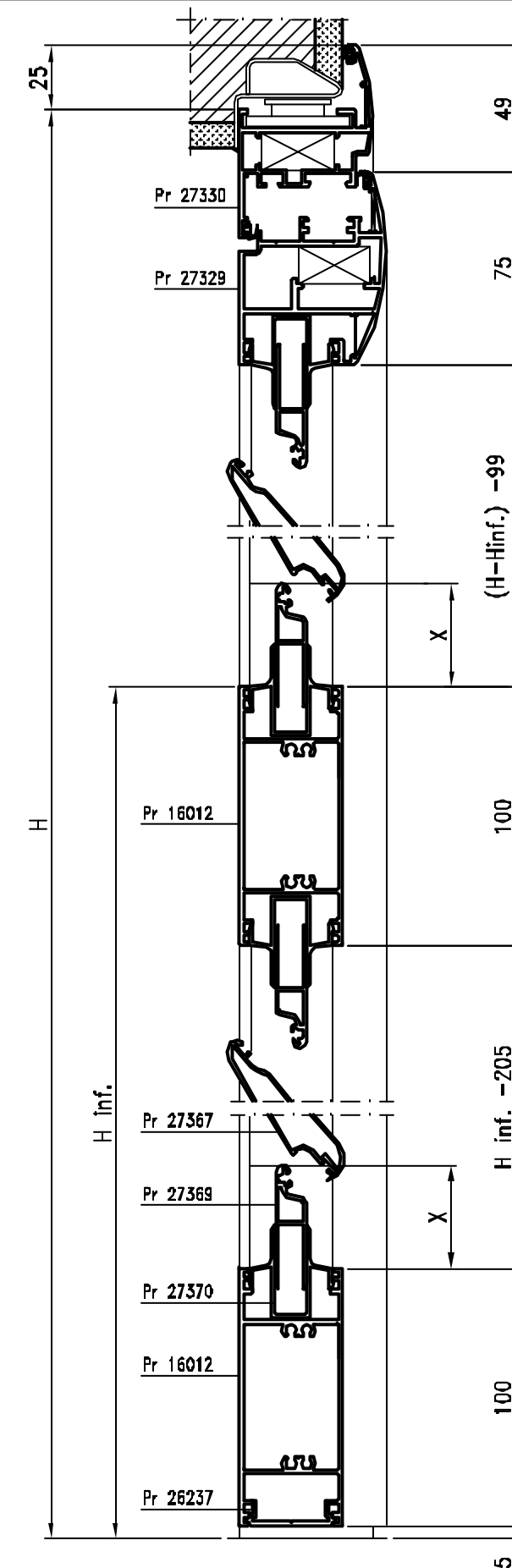
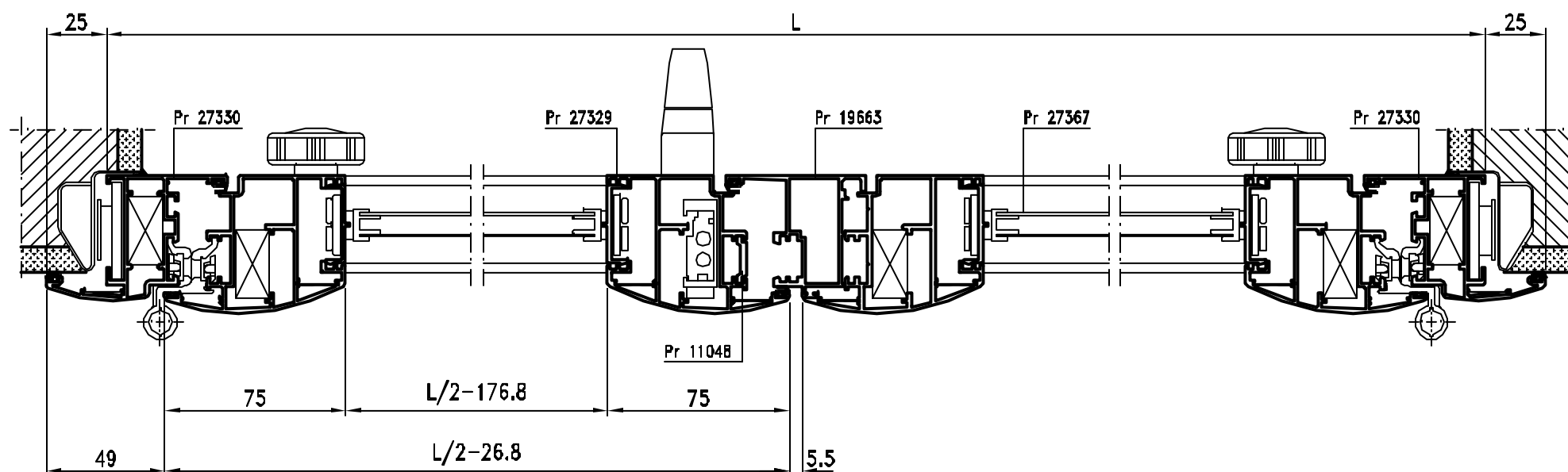

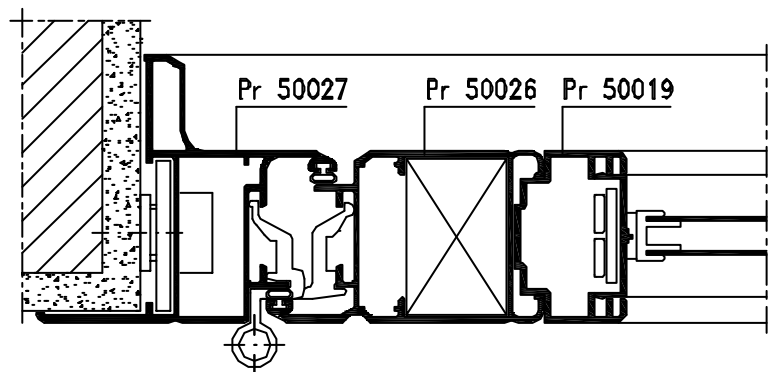
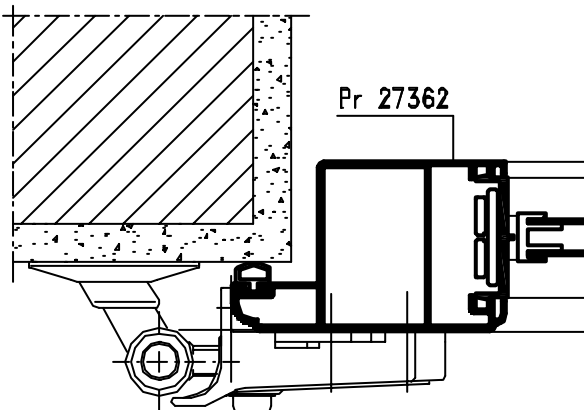
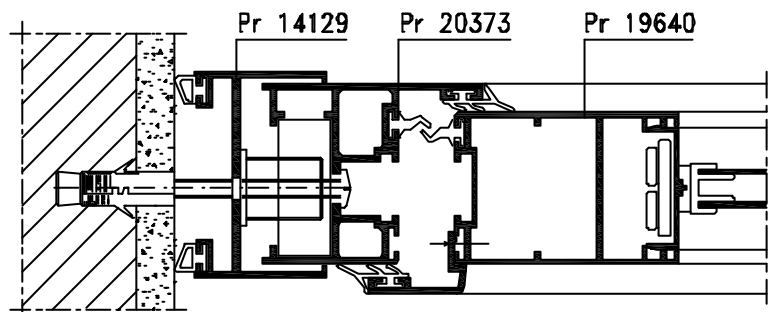
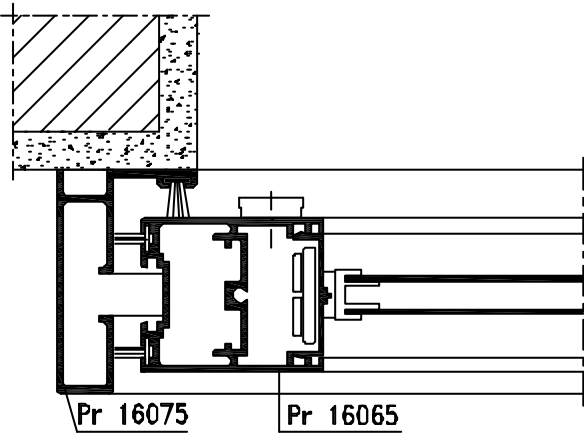
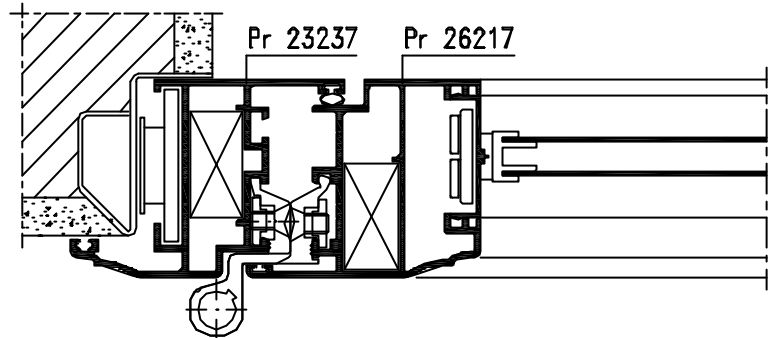
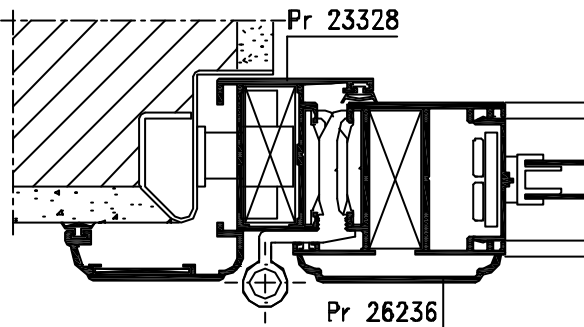
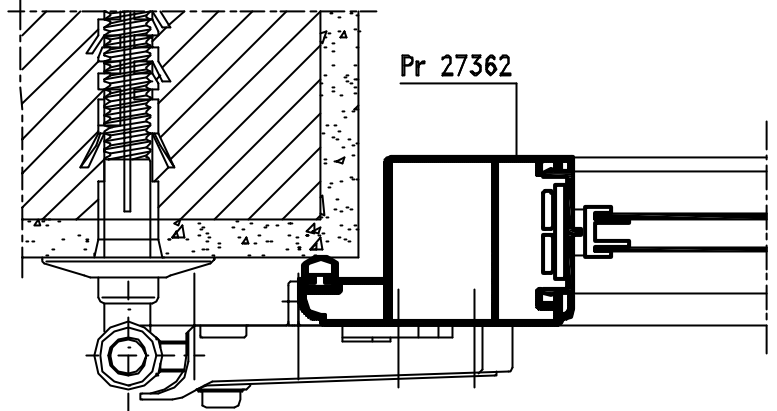
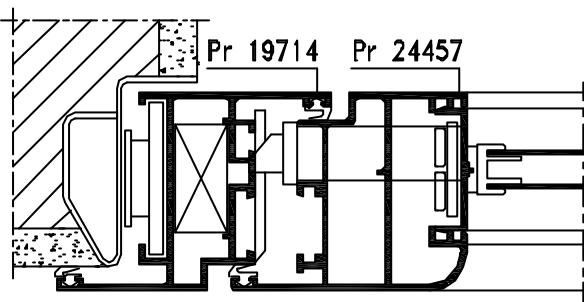

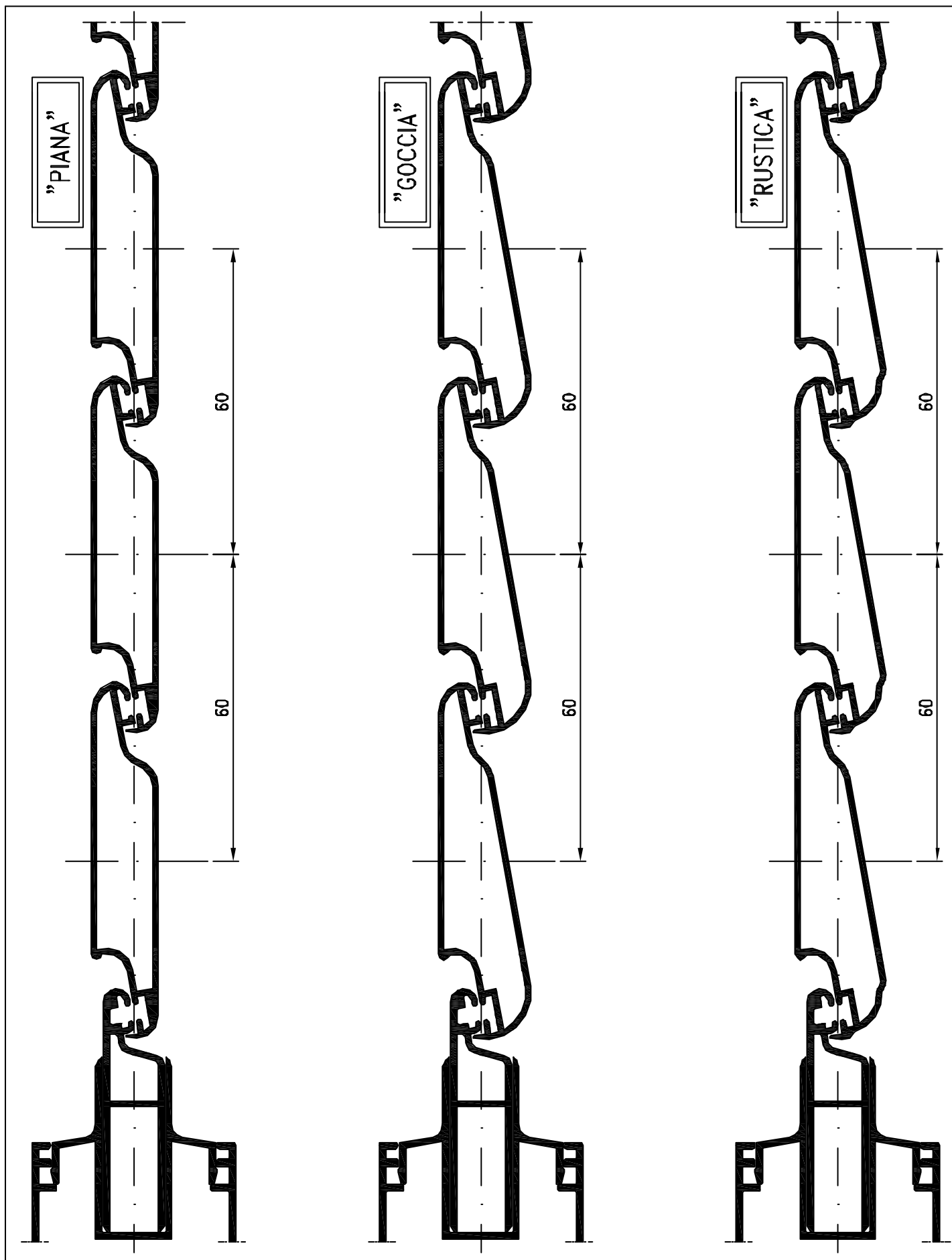

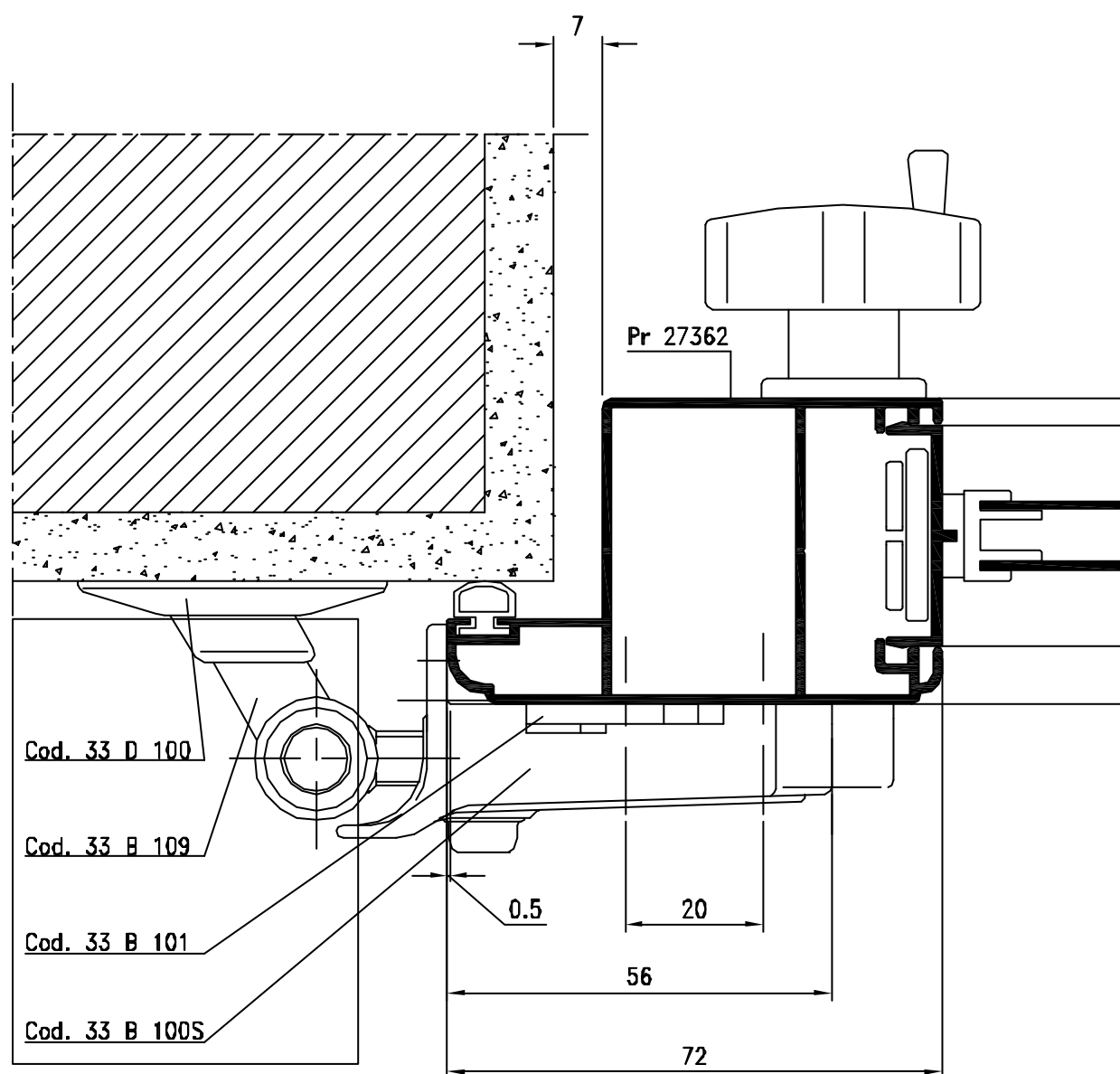
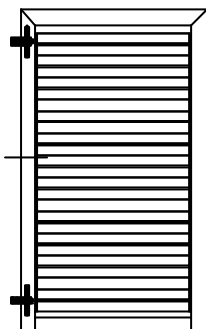

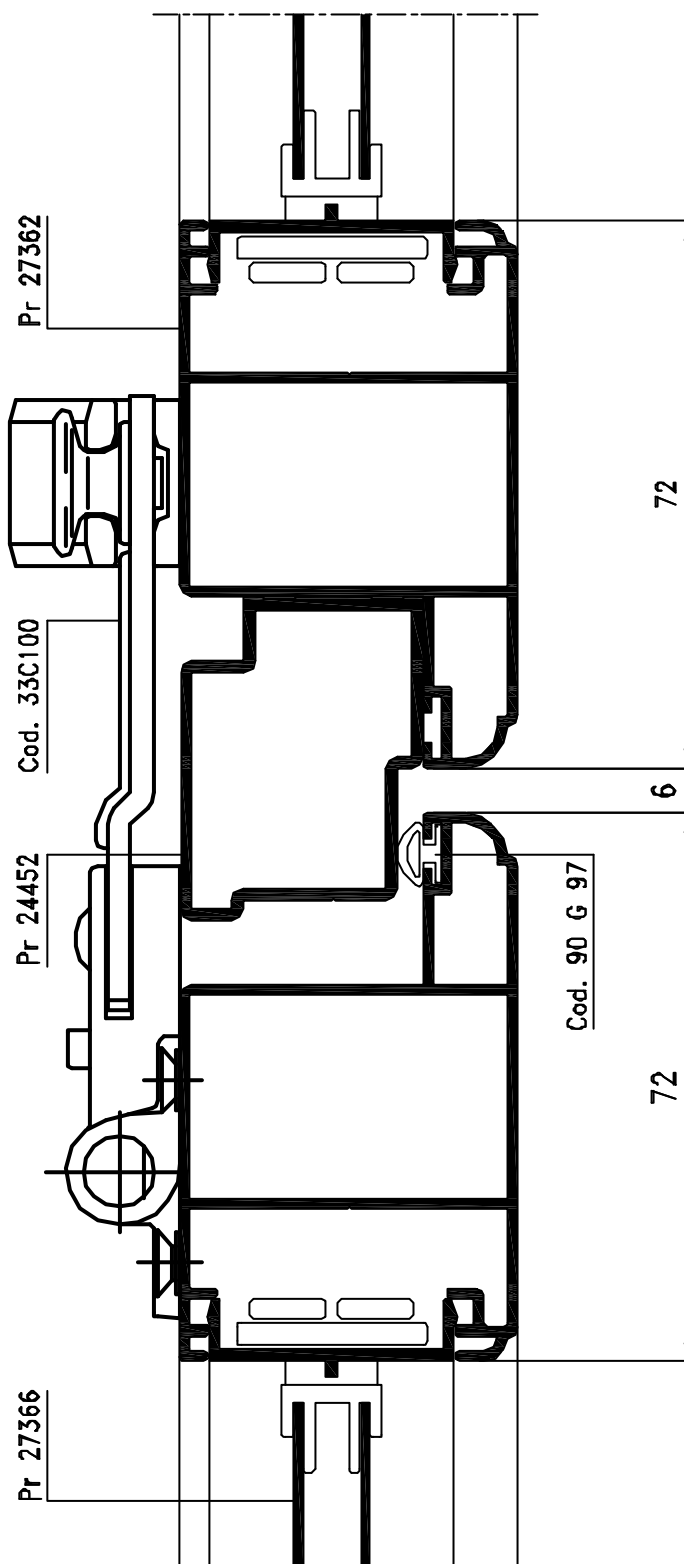
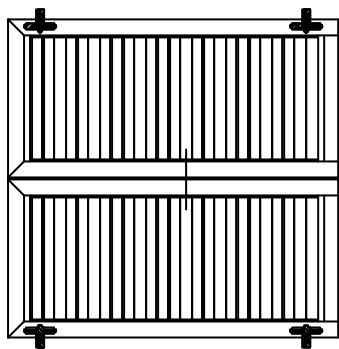

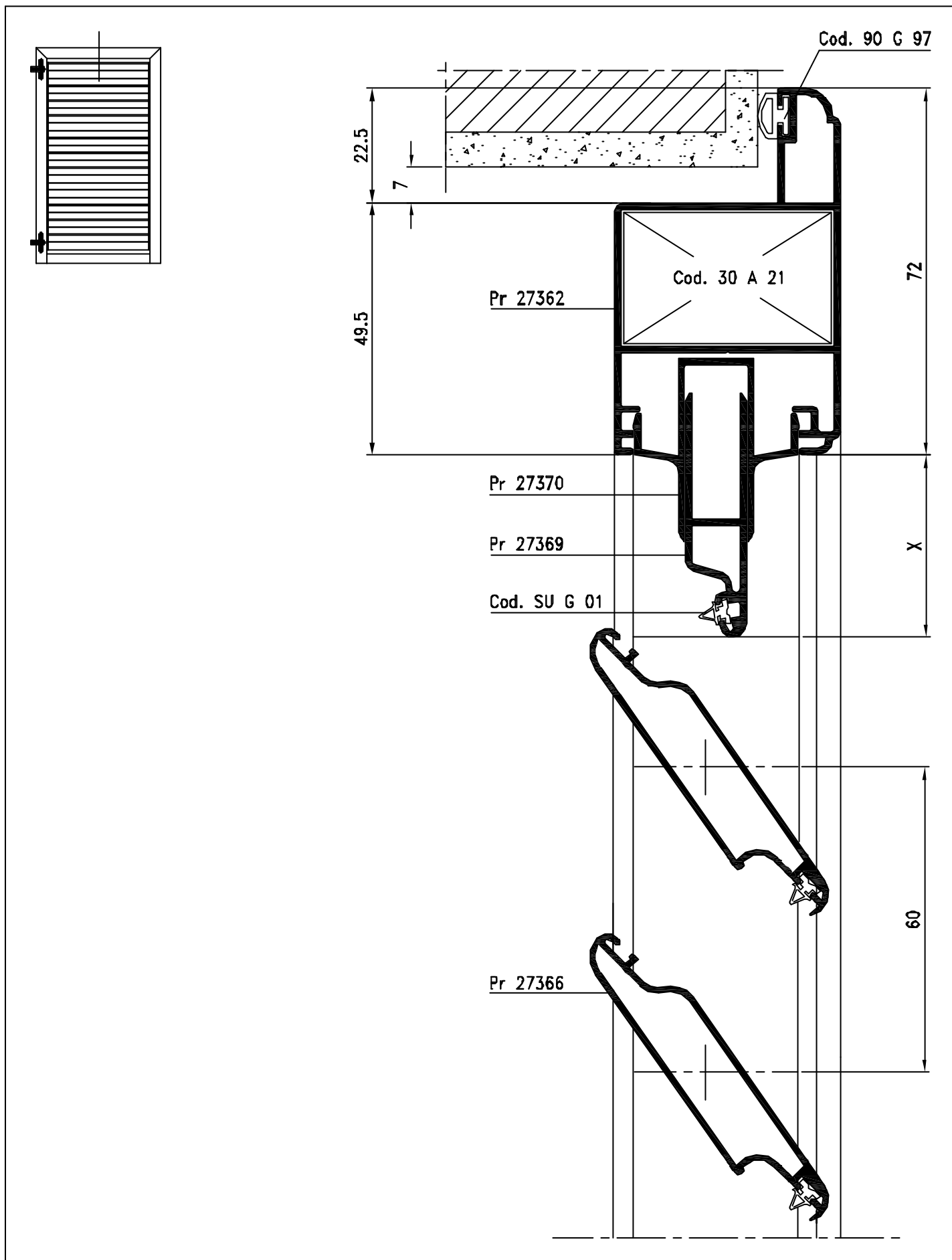

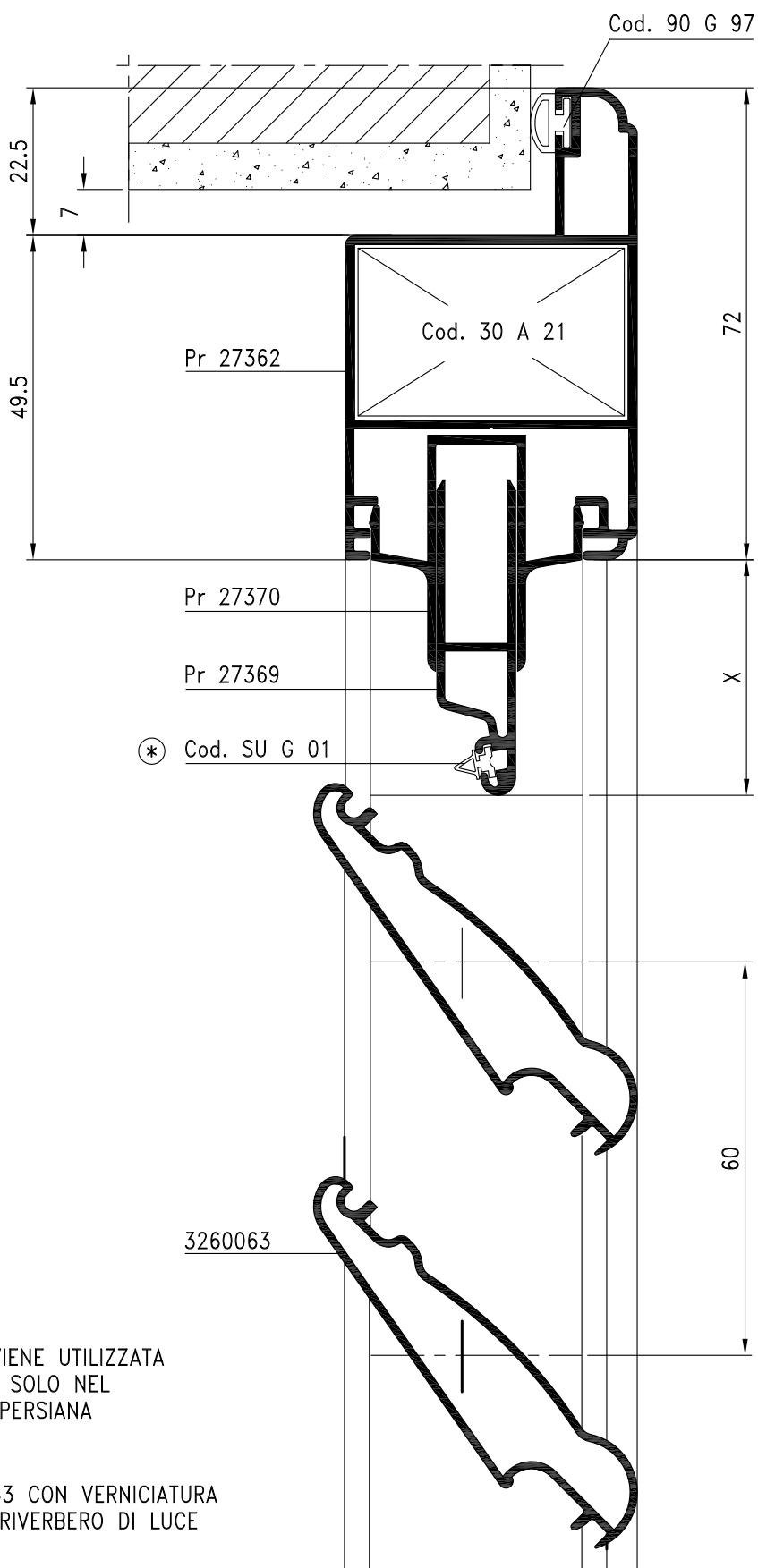
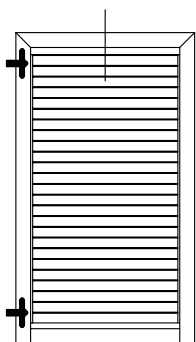

* LA GUARNIZIONE SUG01 QUANDO VIENE UTILIZZATA LA LAMELLA 3260063 VA INSERITA SOLO NEL COMPENSATORE SUPERIORE DELLA PERSIANA

N.B. L'UTILIZZO DELLA LAMELLA 3260063 CON VERNICIATURA DI COLORE CHIARO, PROVOCA UN RIVERBERO DI LUCE NON ELIMINABILE

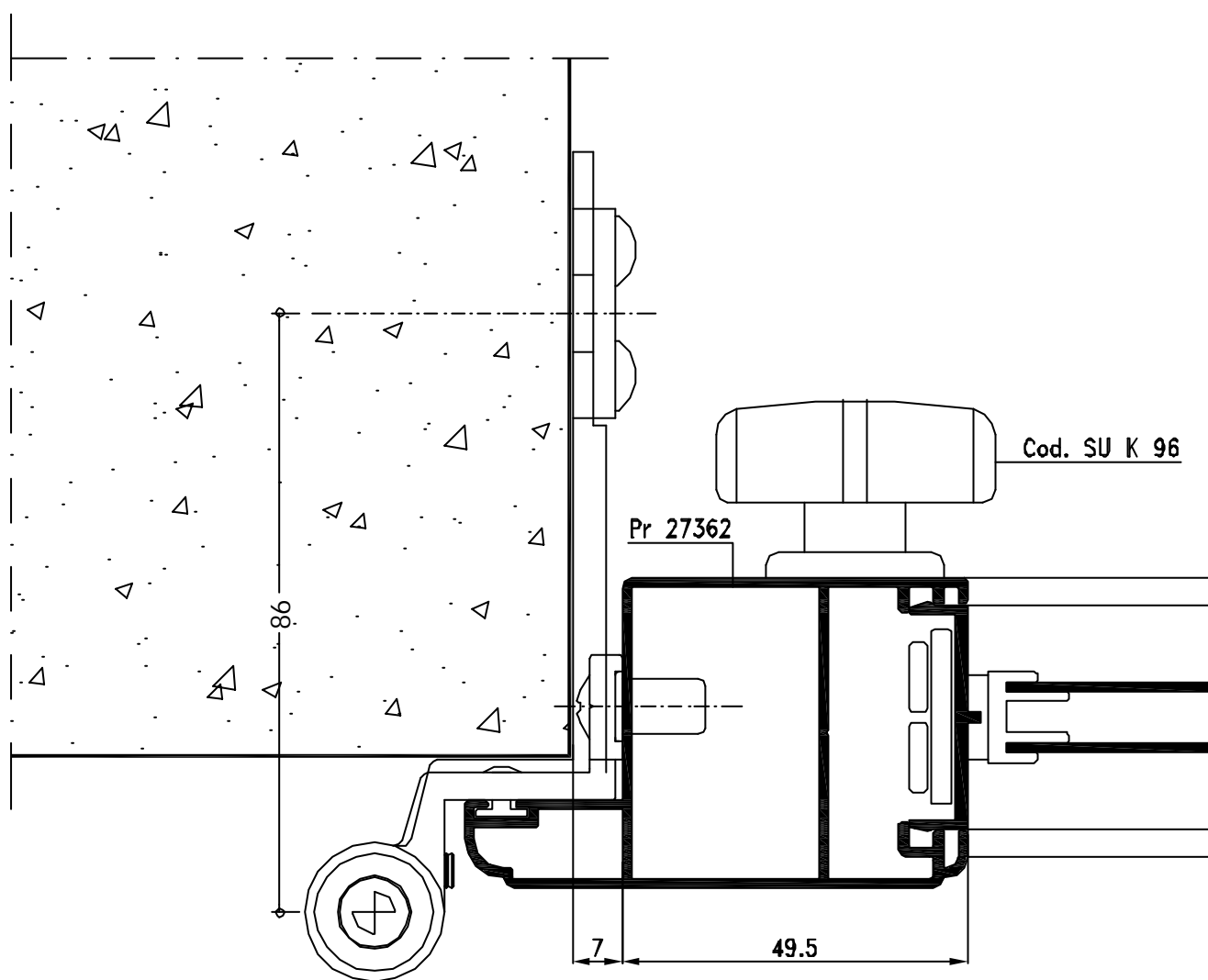

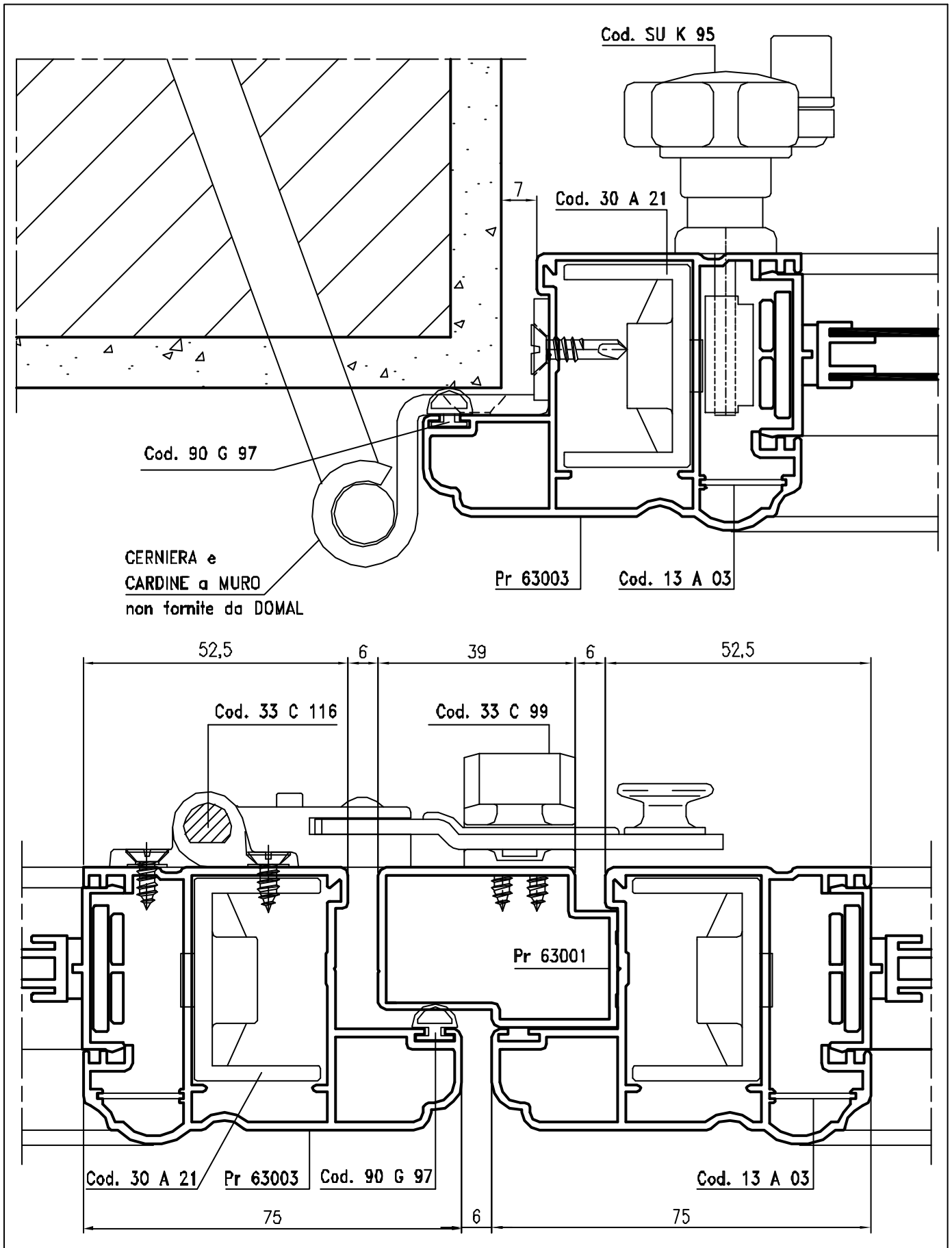

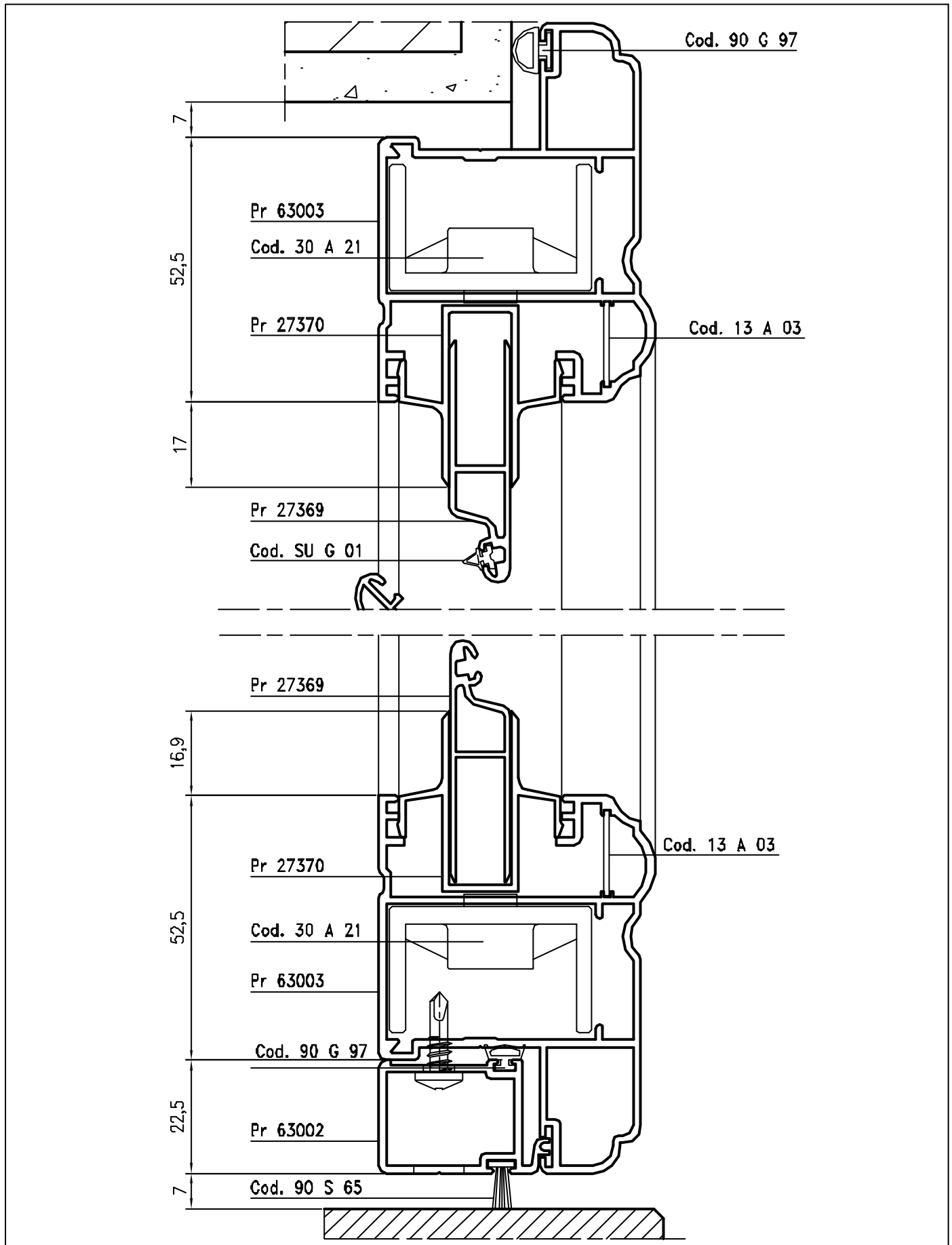

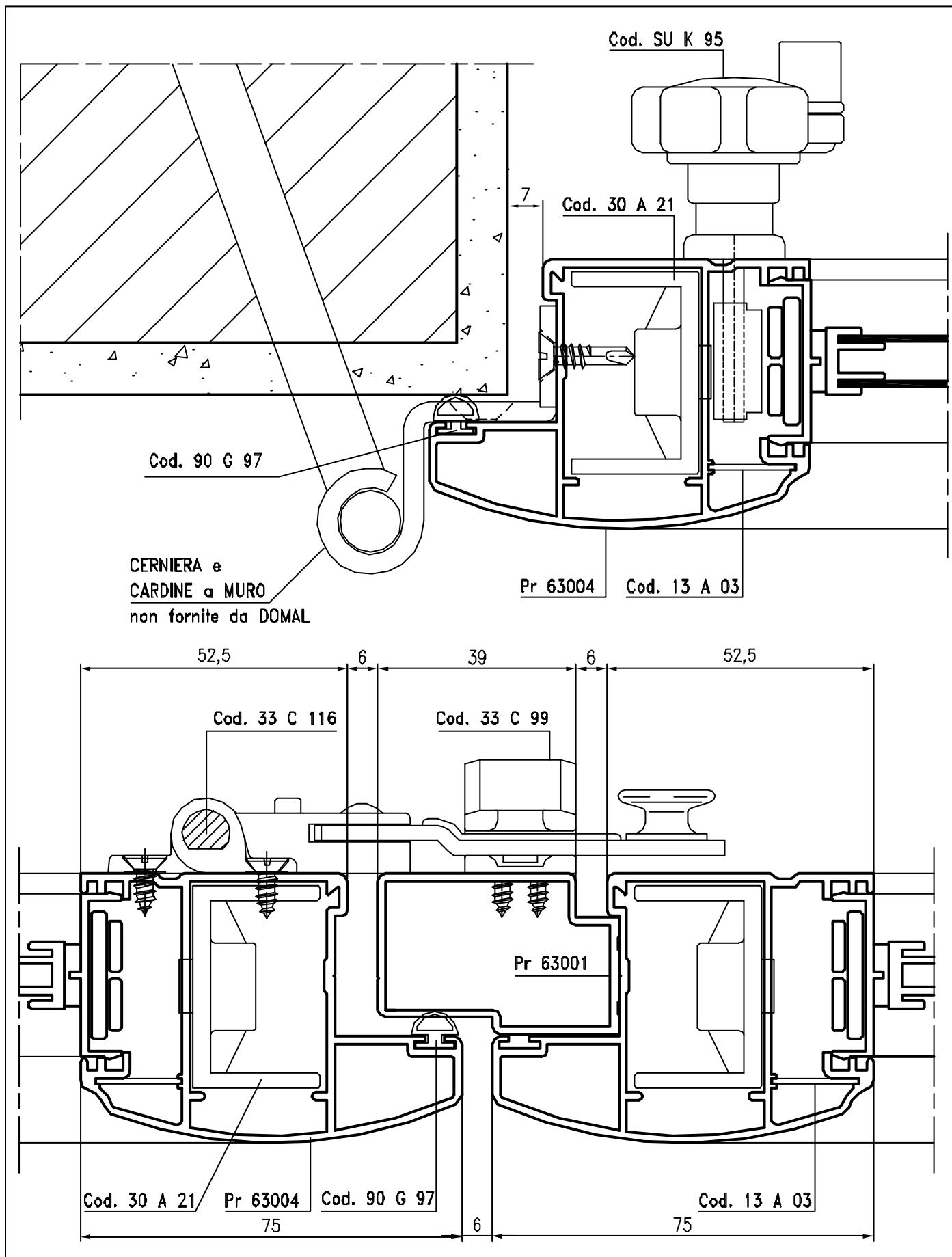

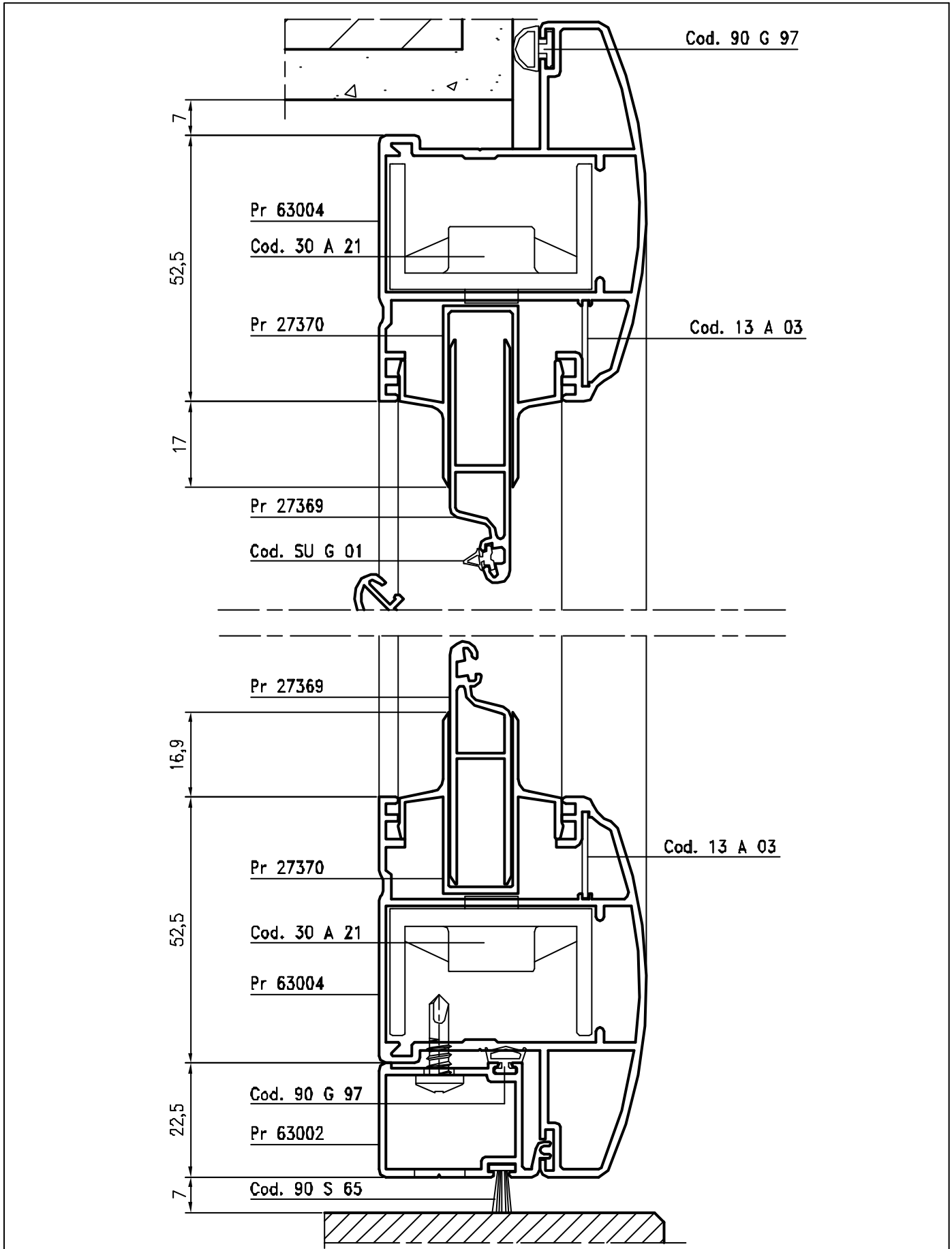

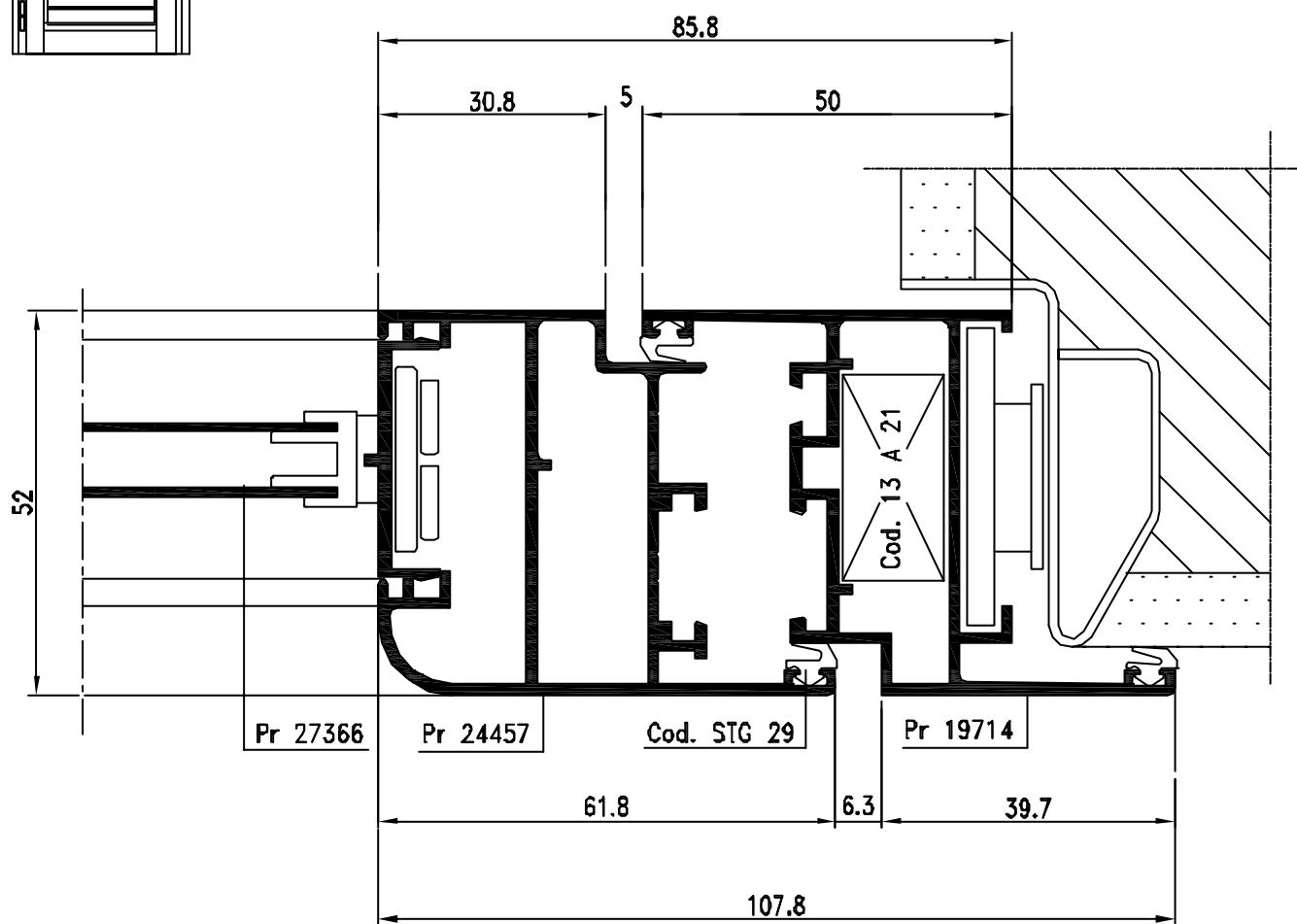
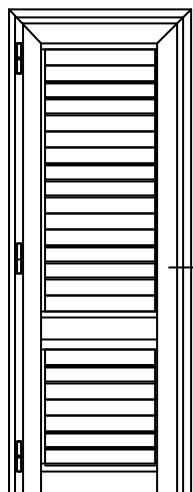

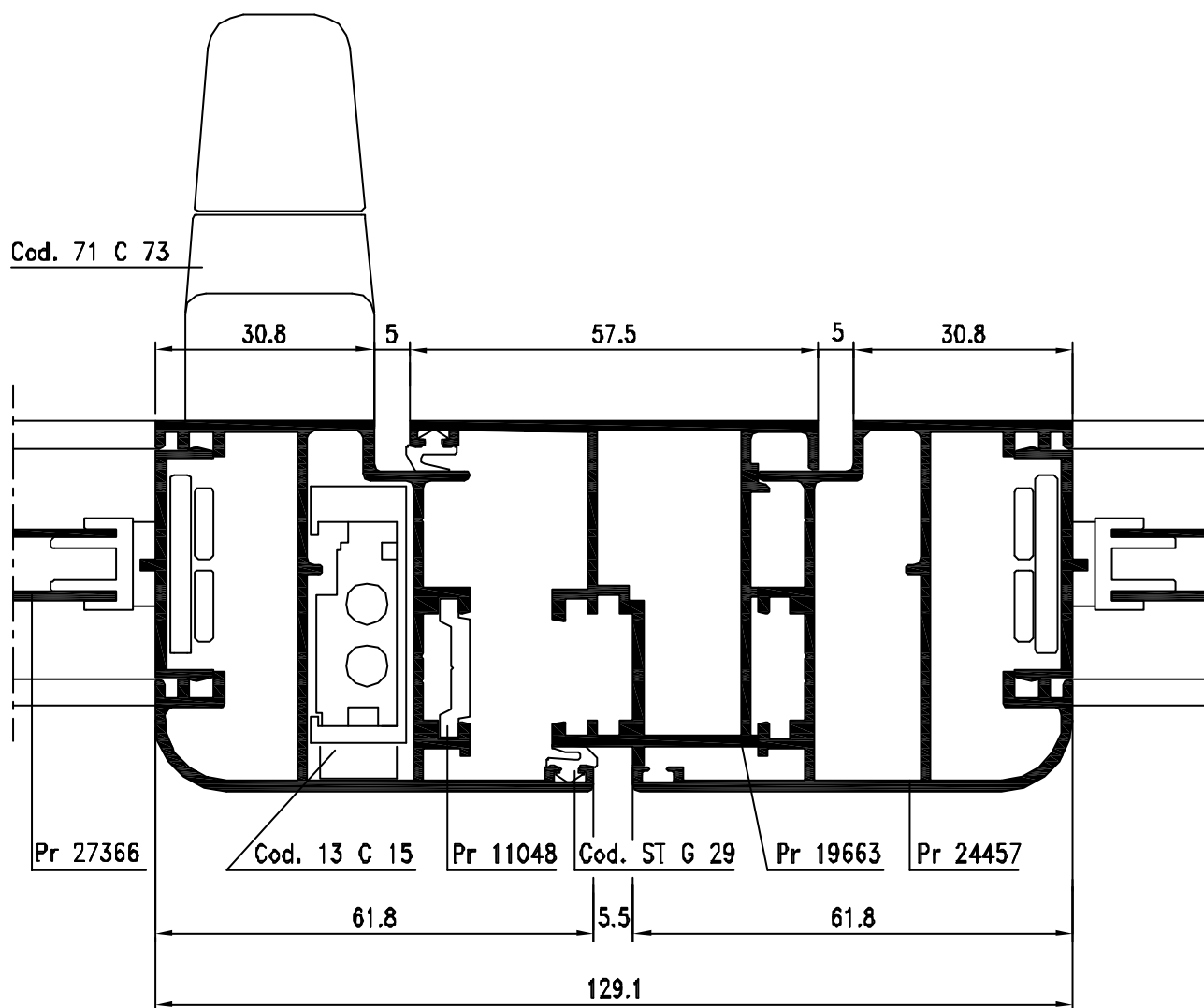
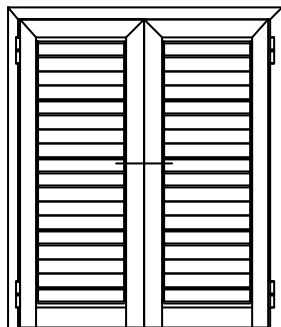

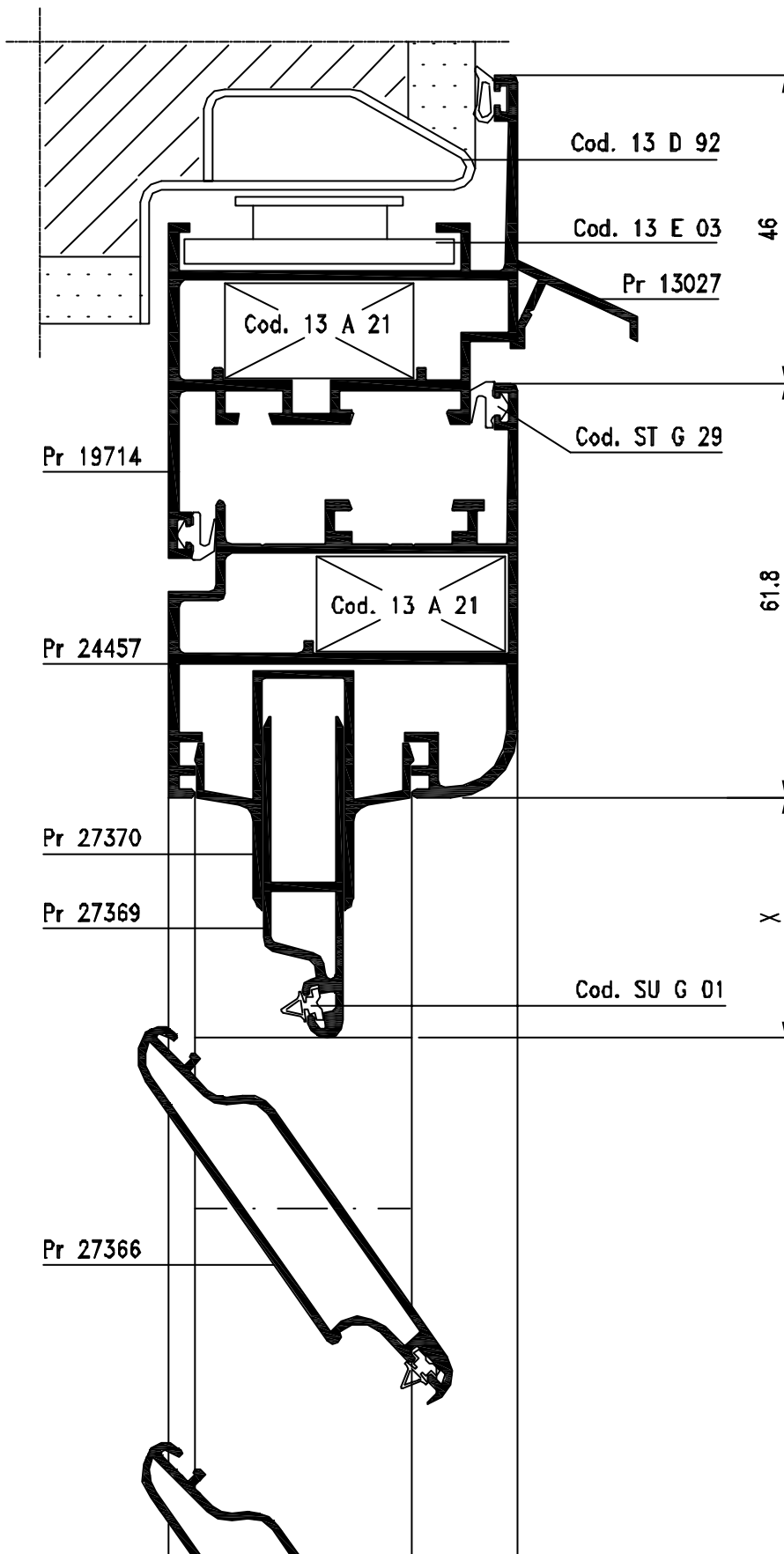
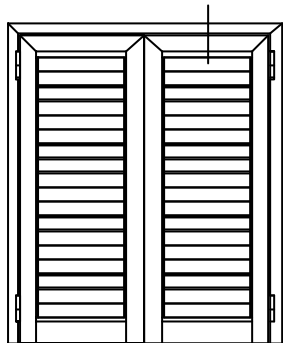

GELOSIA PORTA 1 ANTA
Abbinamento
DOMAL STOPPER PG

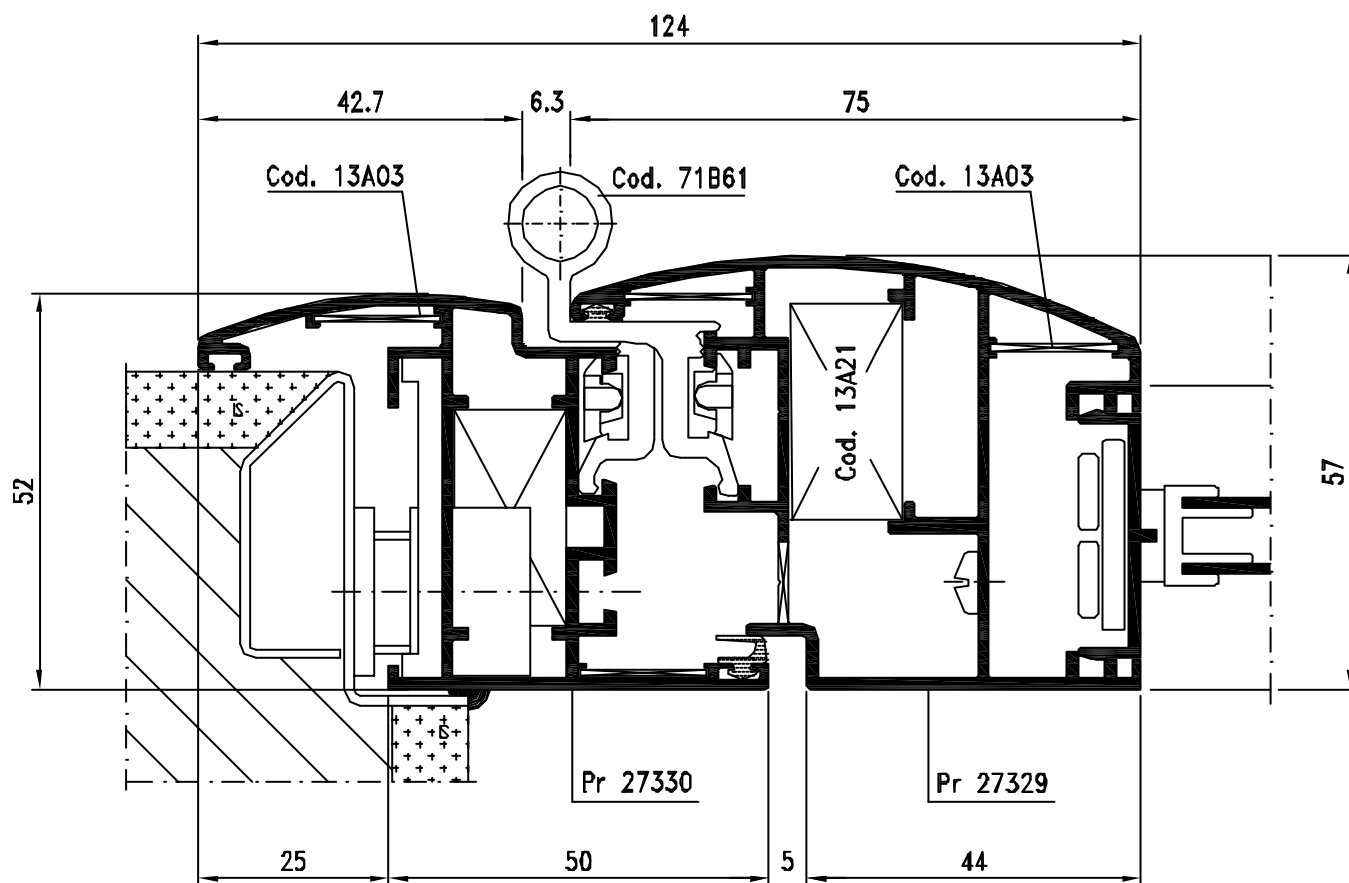
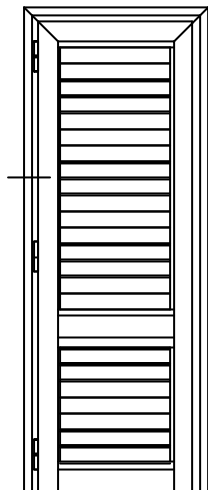

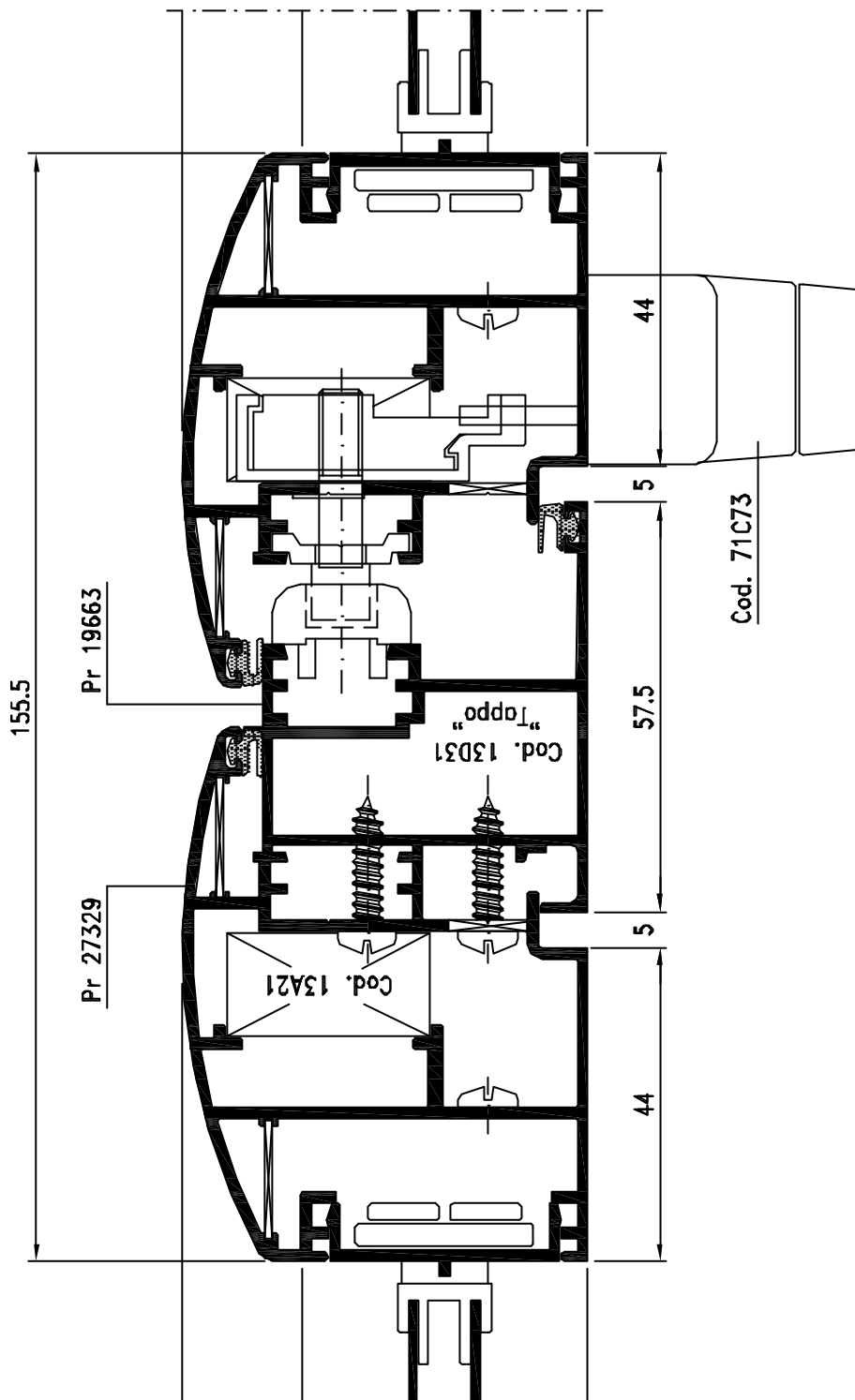

GELOSIA PORTA 2 ANTE
Abbinamento
DOMAL STOPPER PG

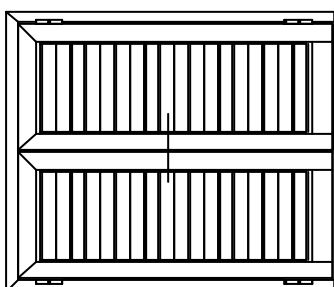

GELOSIA PORTA 1 ANTA
 Abbinamento
 DOMAL STOPPER PG

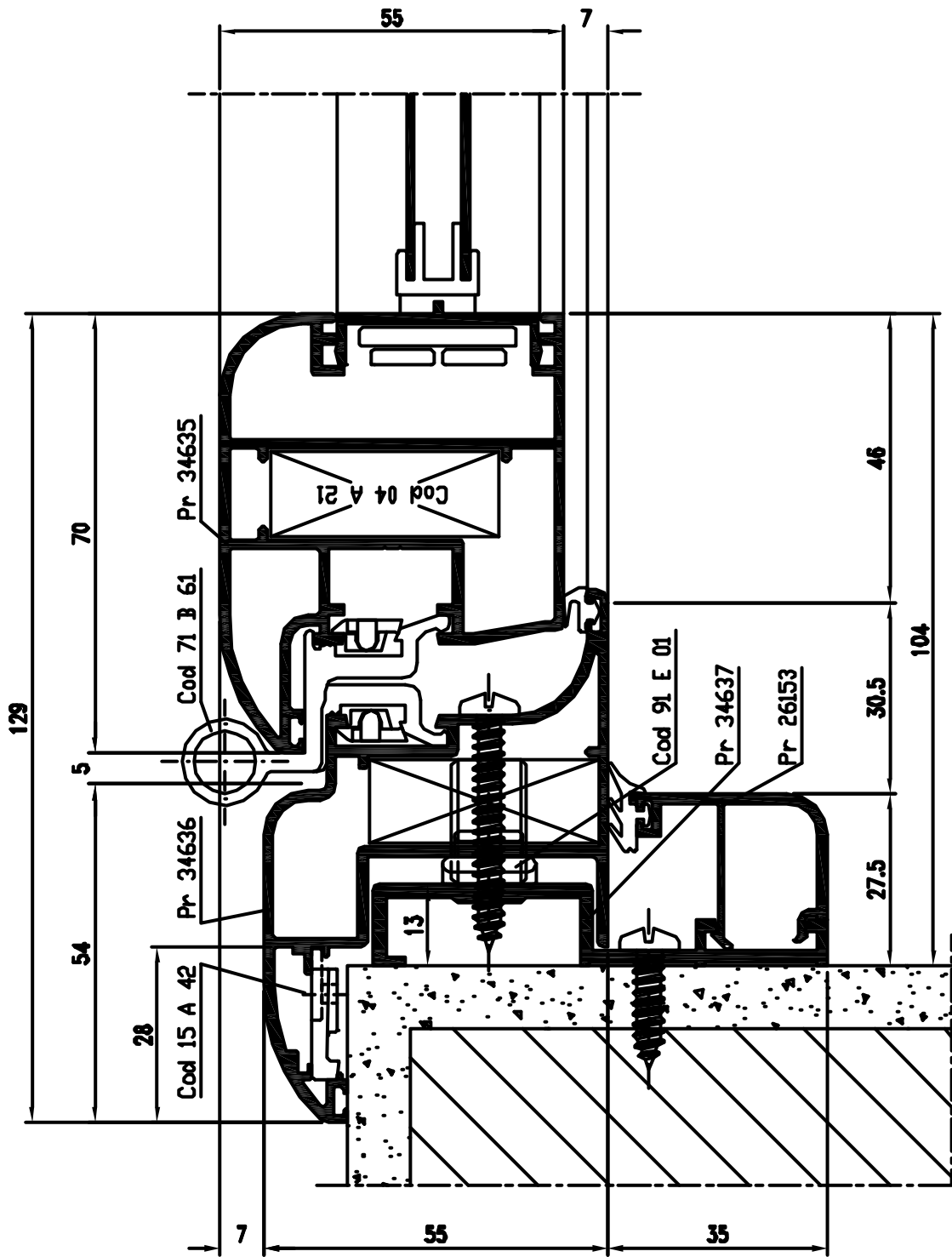
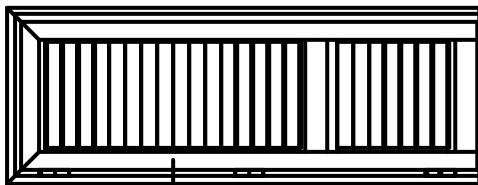

GELOSIA PORTA 1 ANTA
Abbinamento
DOMAL STOPPER PG

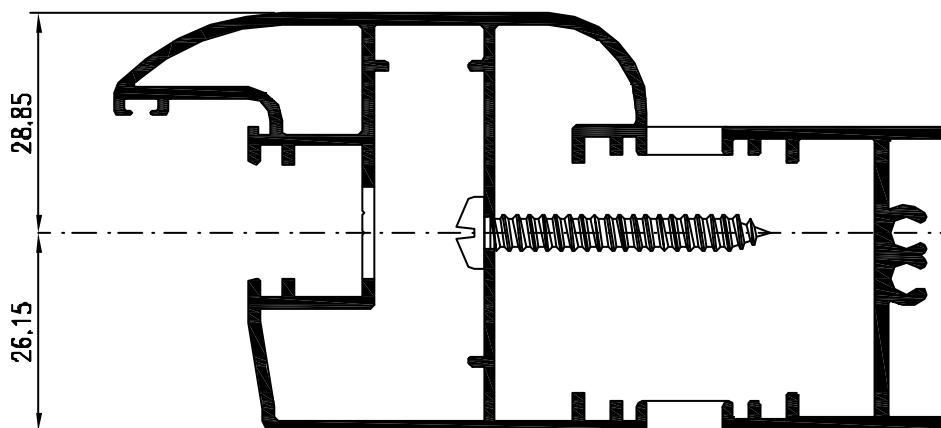
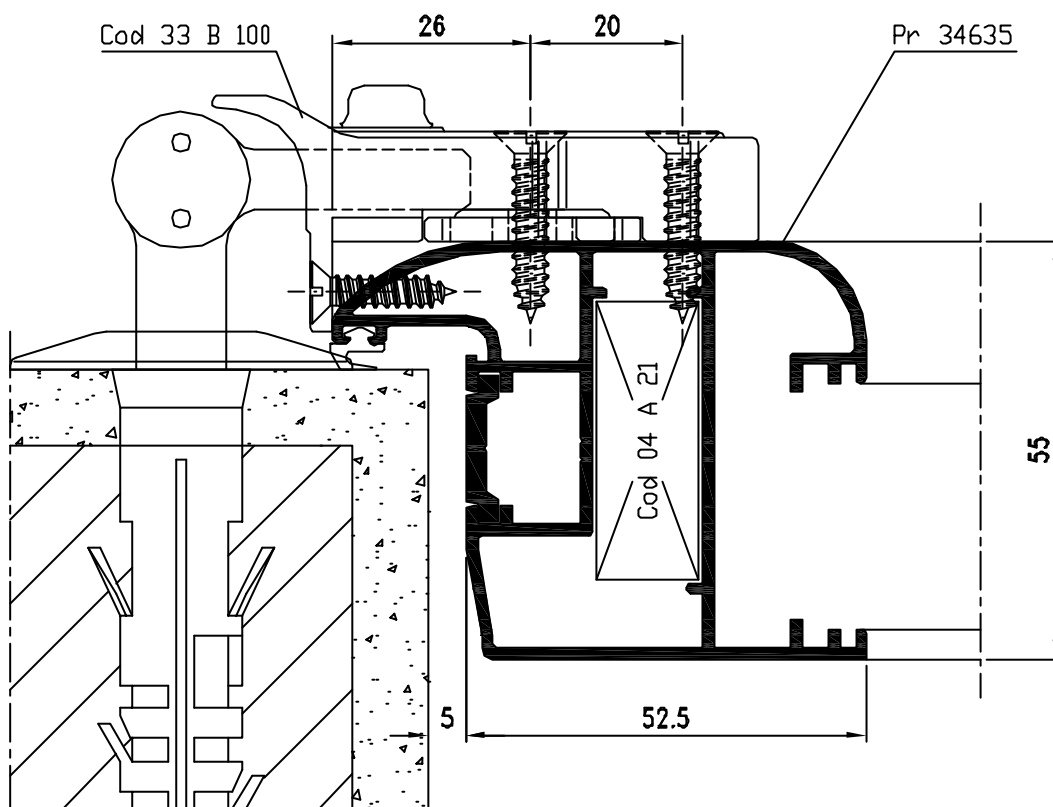
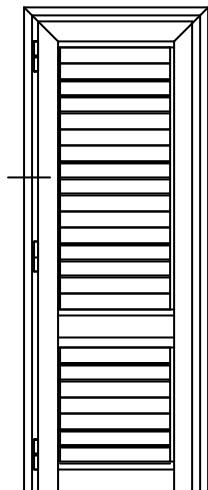

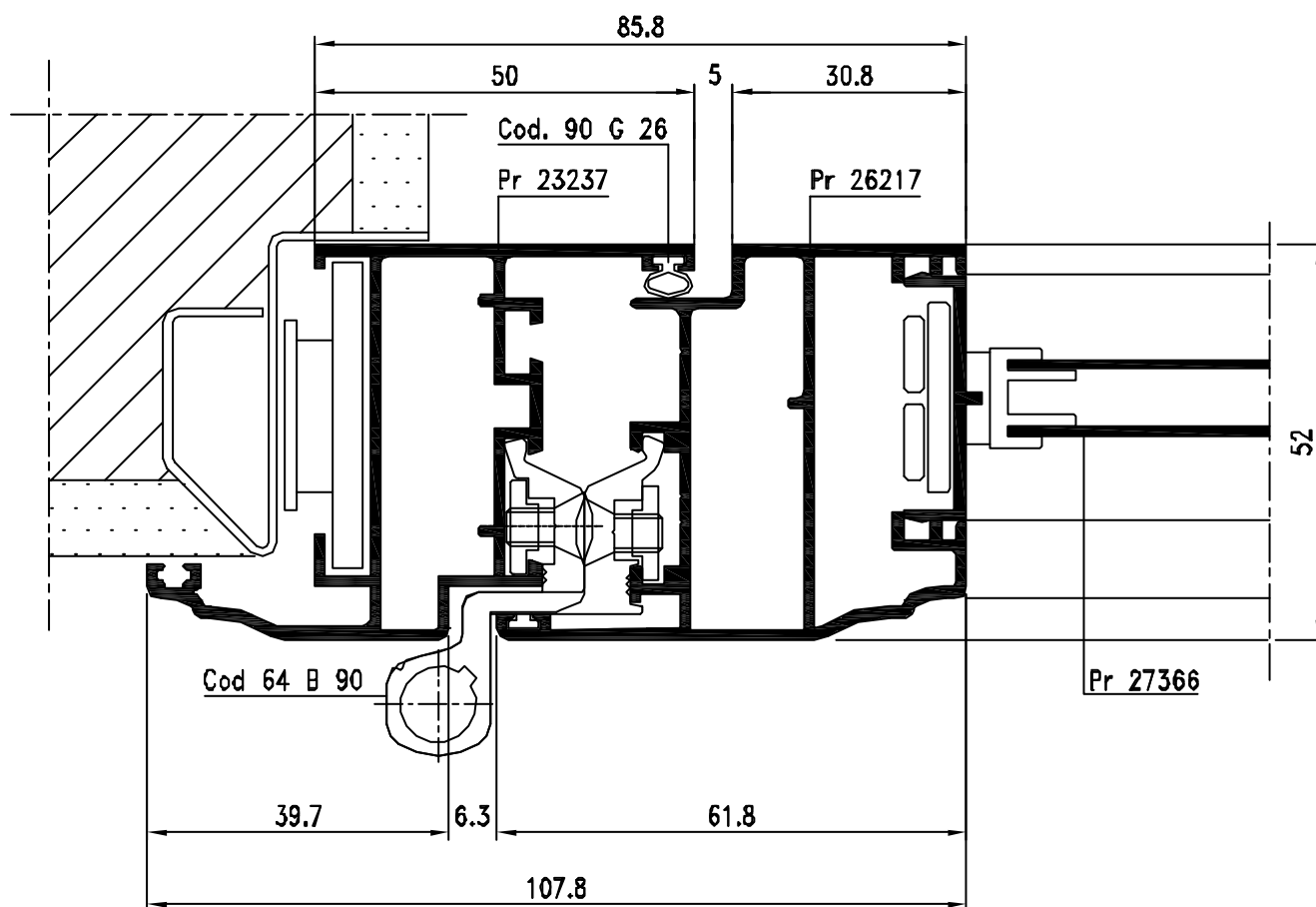
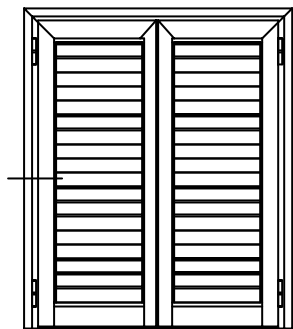

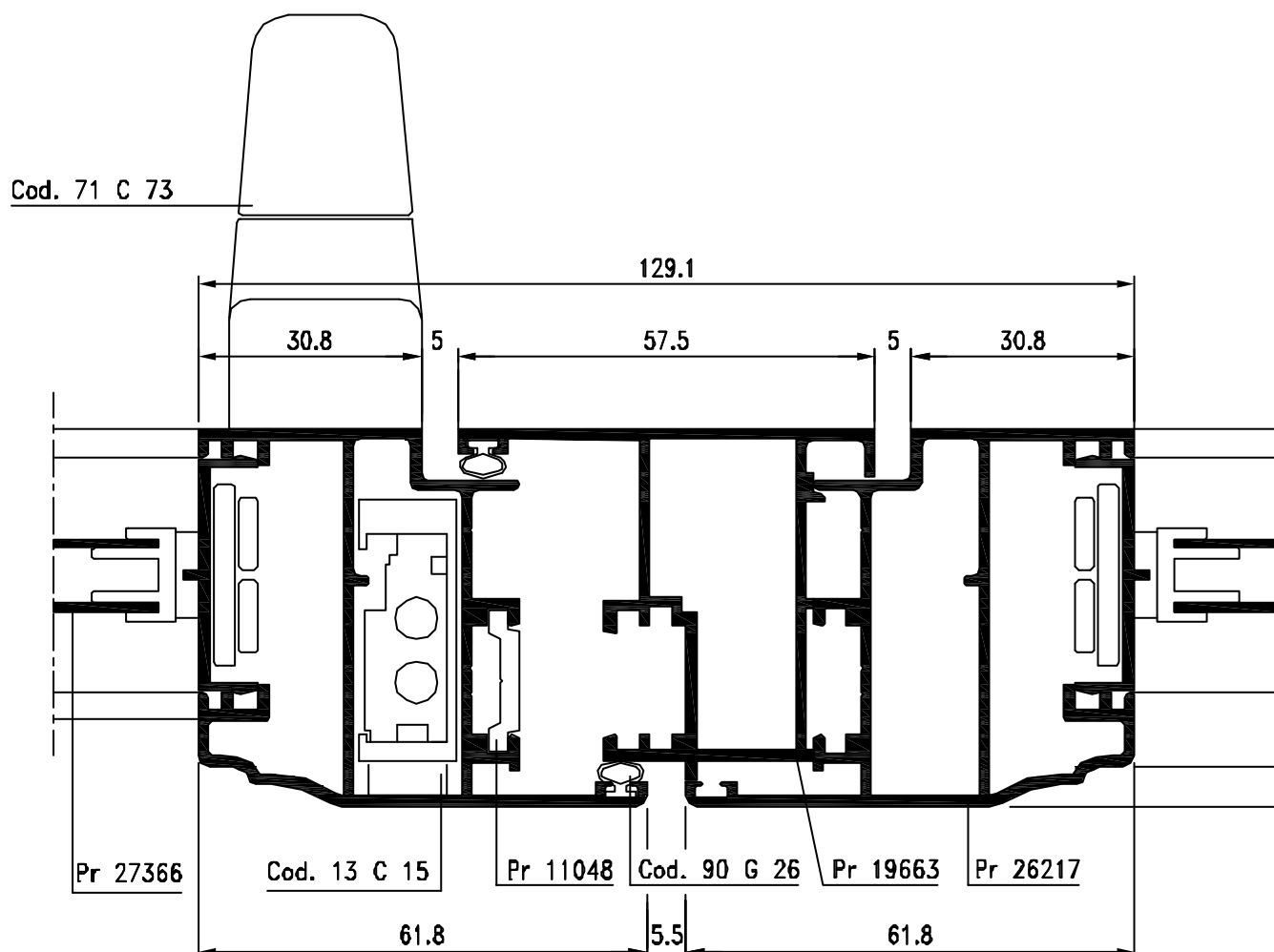
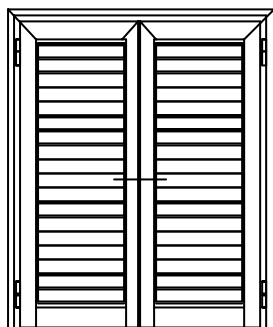

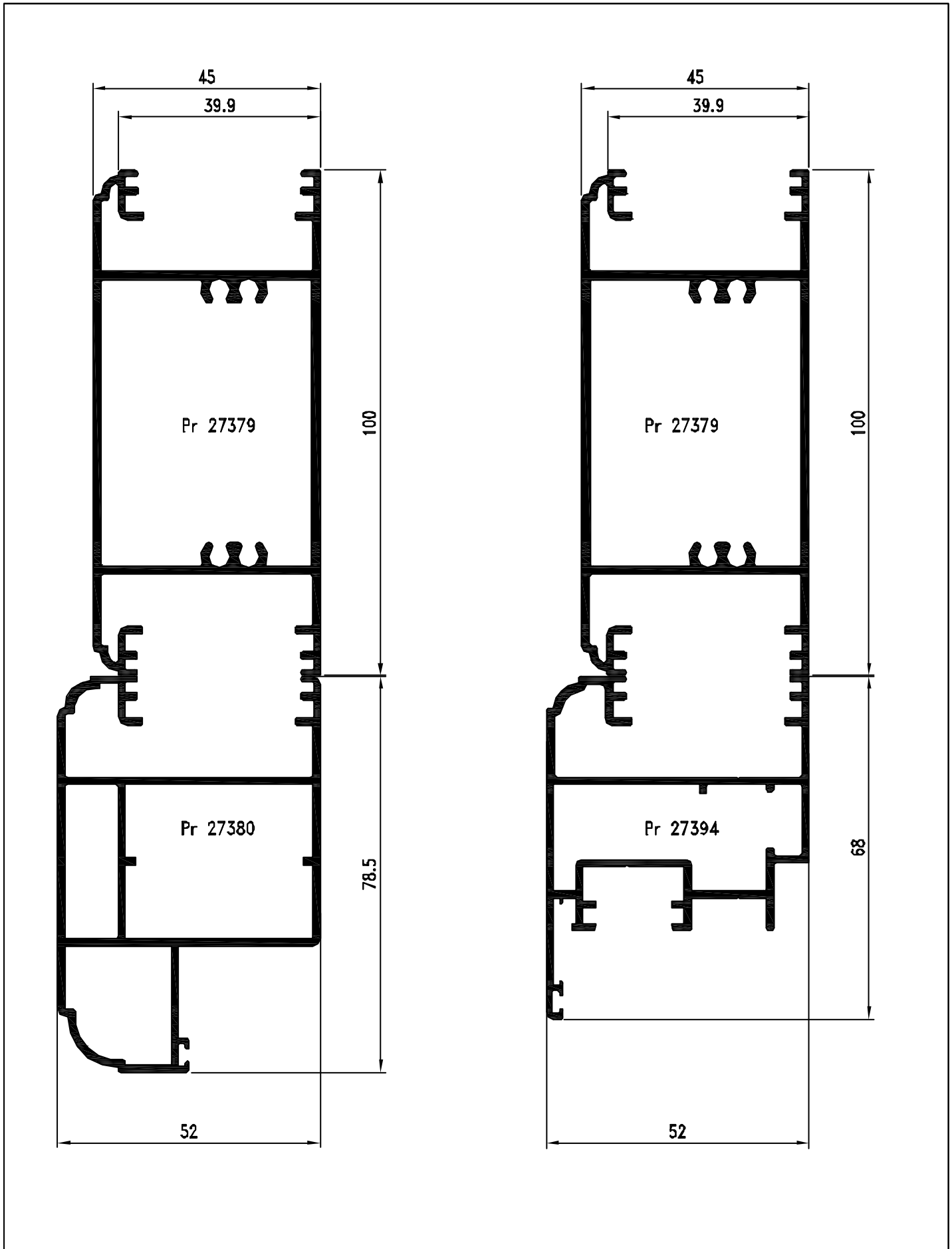

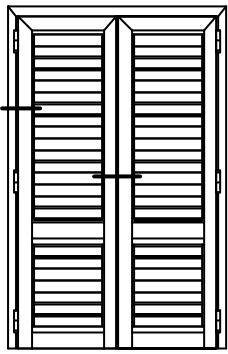

GELOSIA PORTA 2 ANTE
 Abbinamento
 DOMAL STOPPER PG

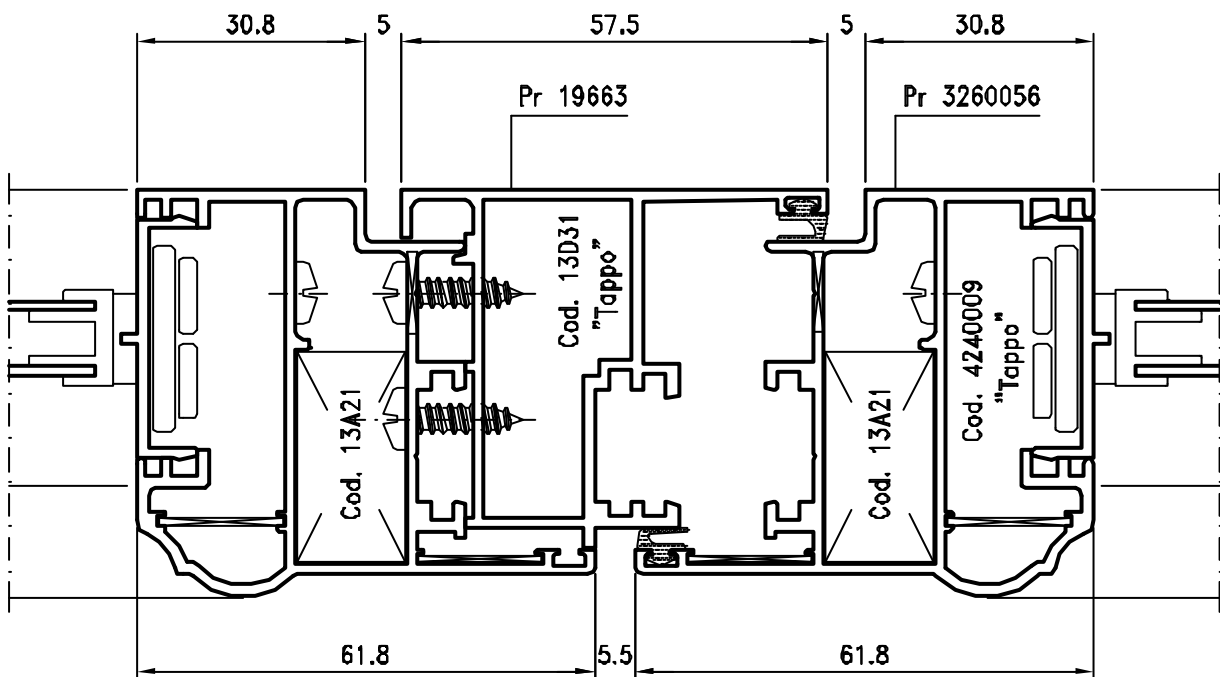
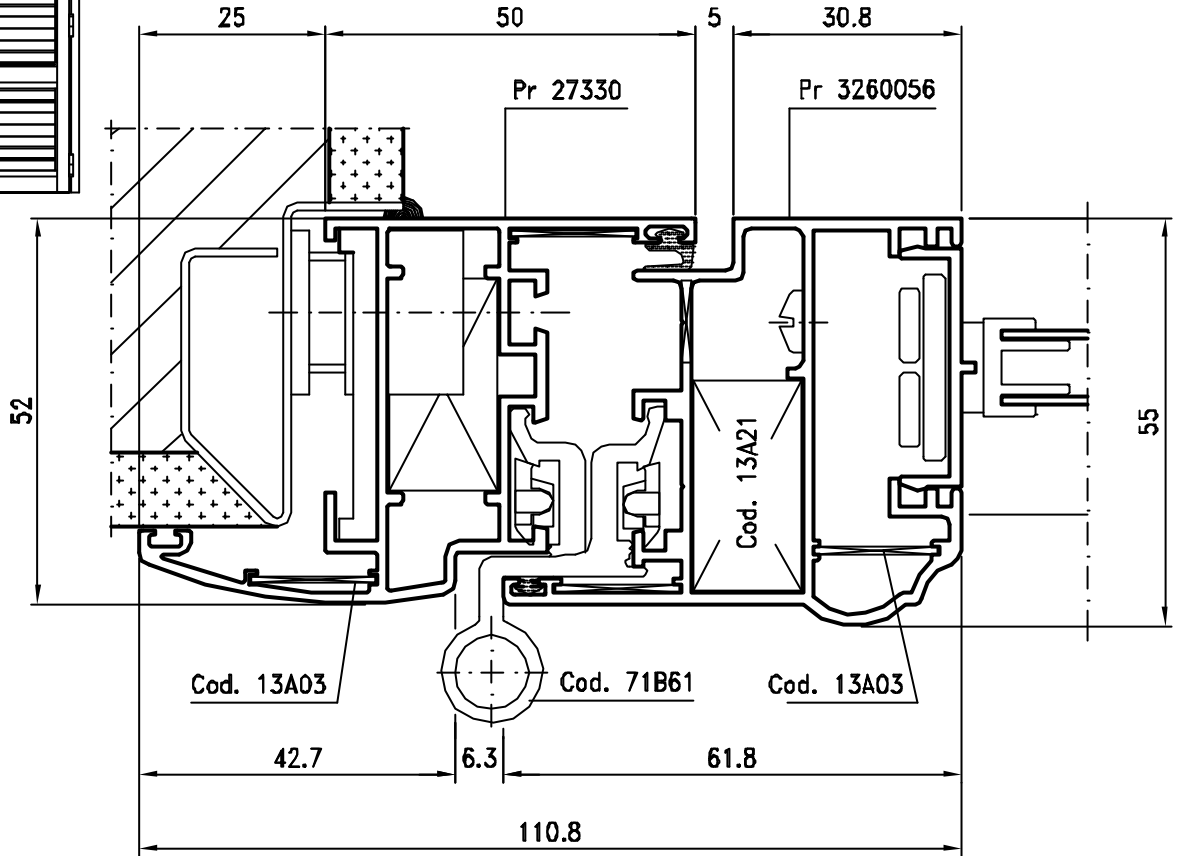

GELOSIA PORTA 2 ANTE
 Abbinamento
 DOMAL STOPPER PG

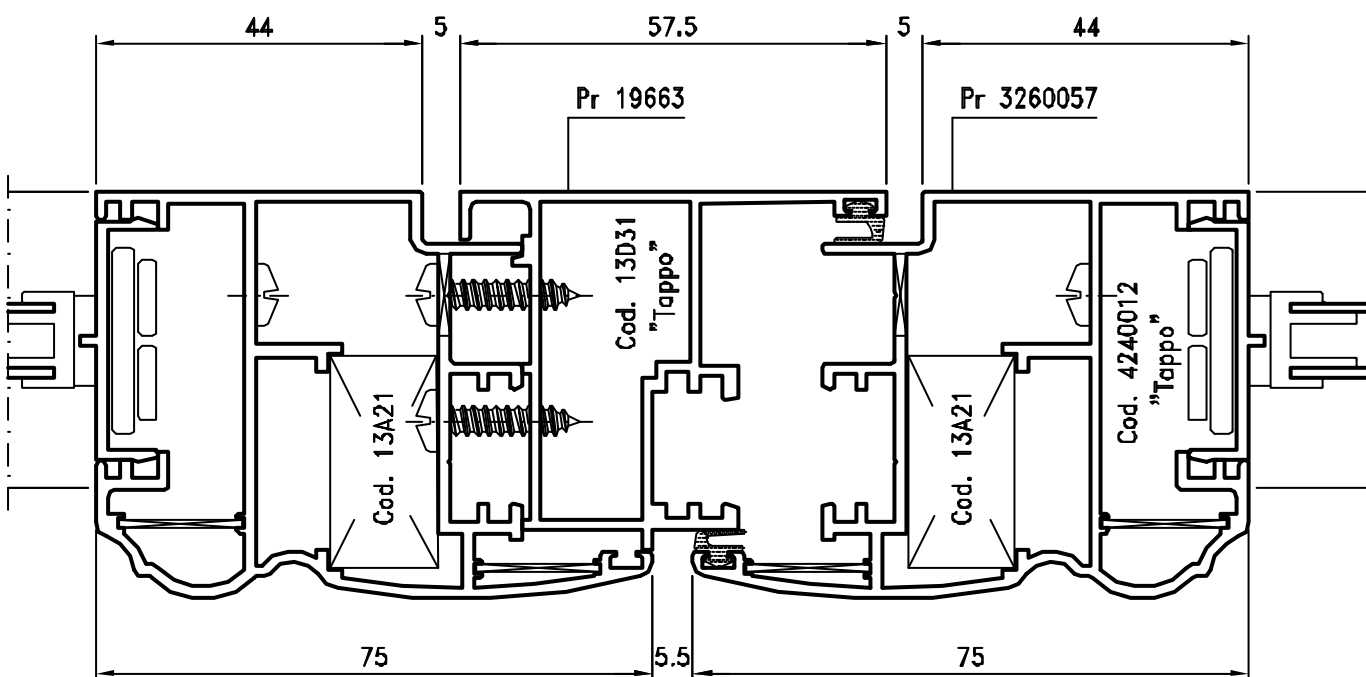
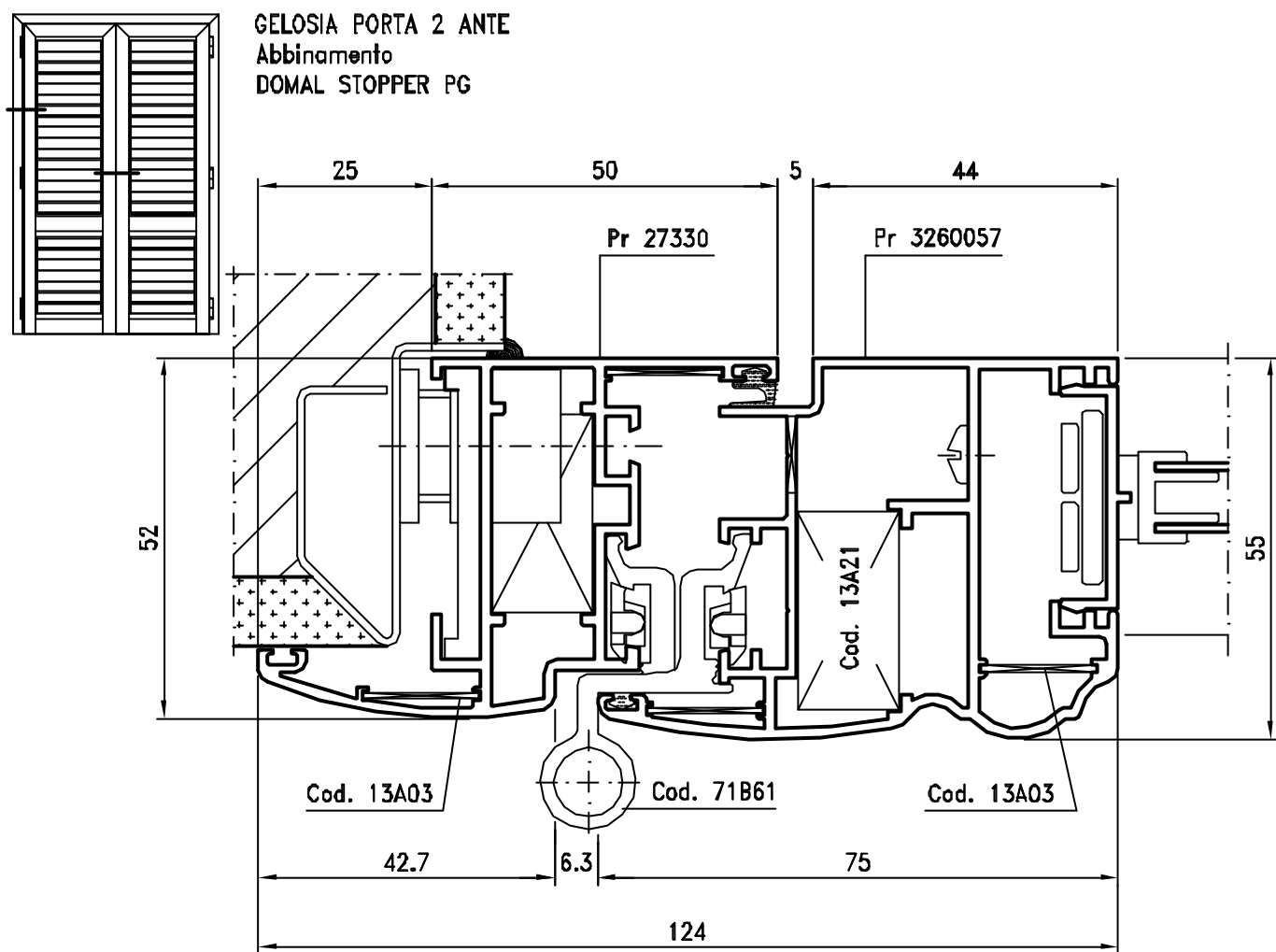

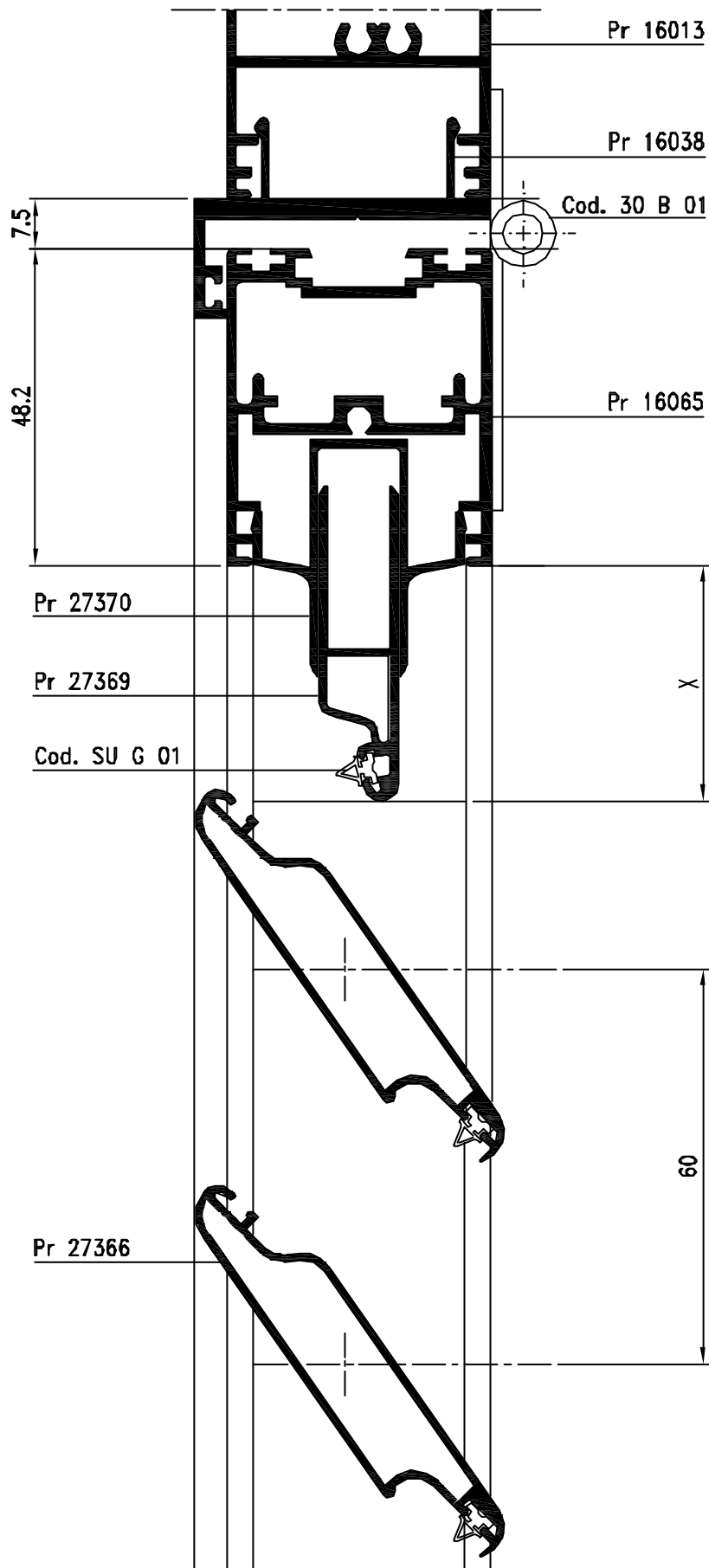
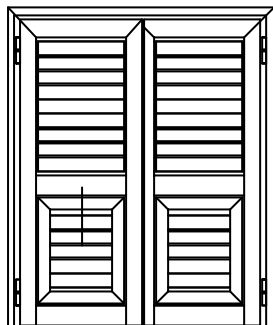

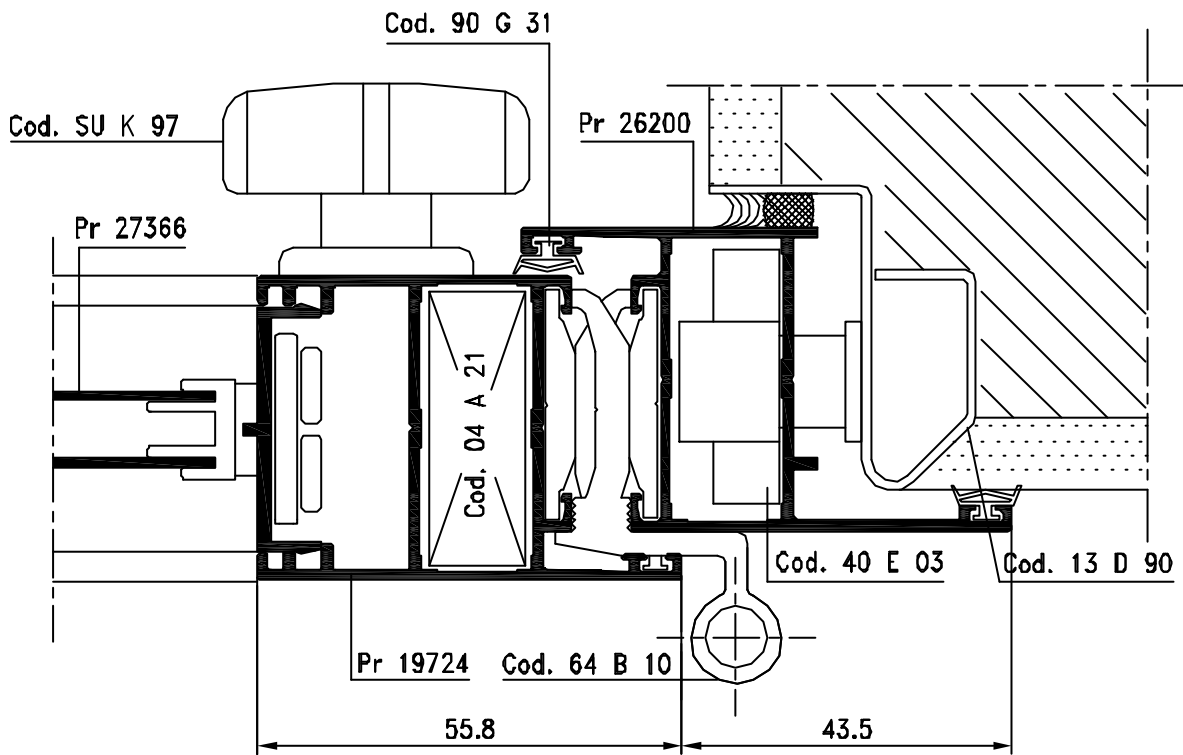
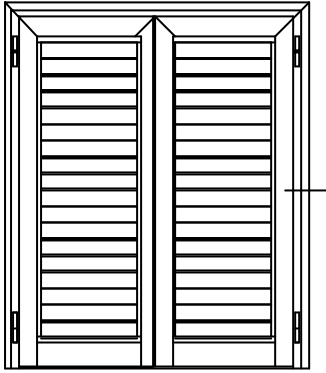

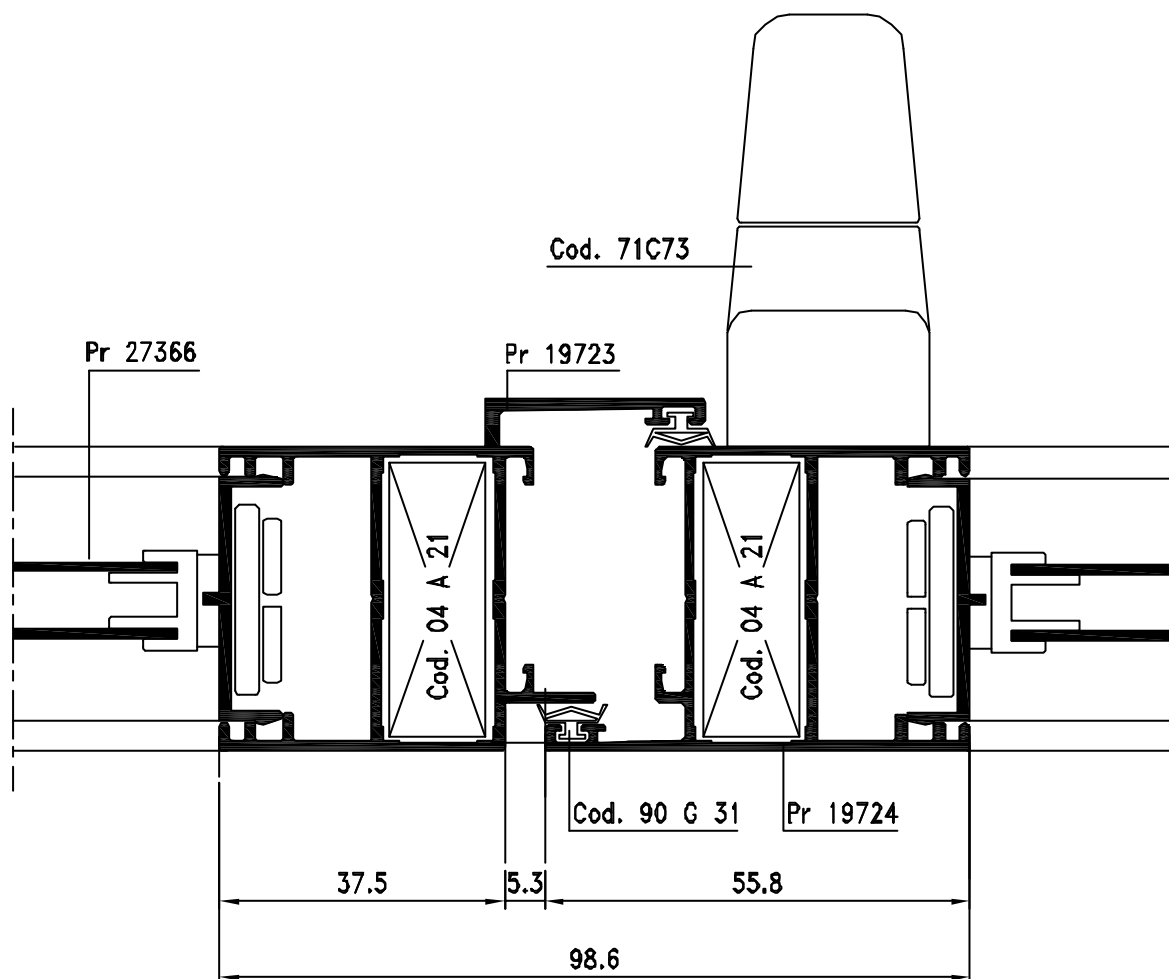
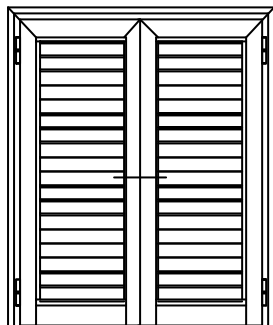

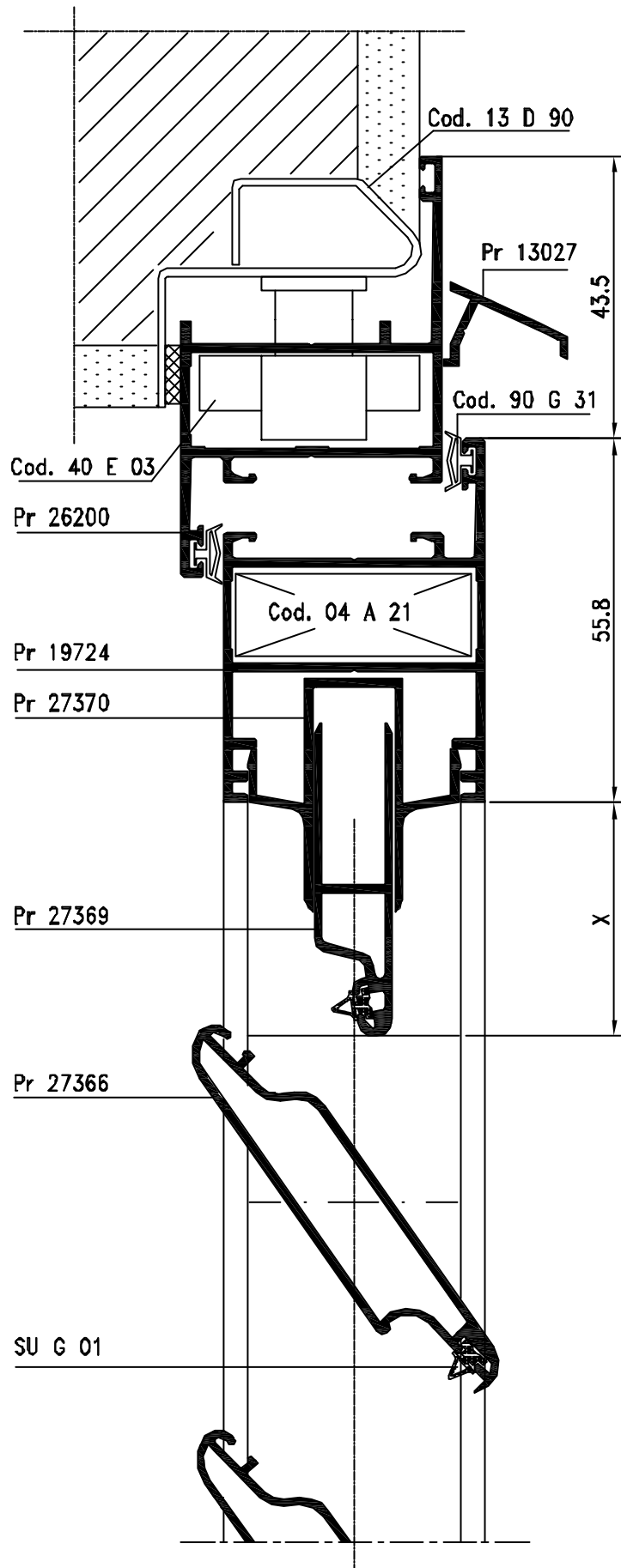
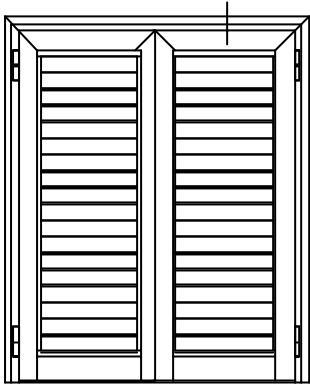

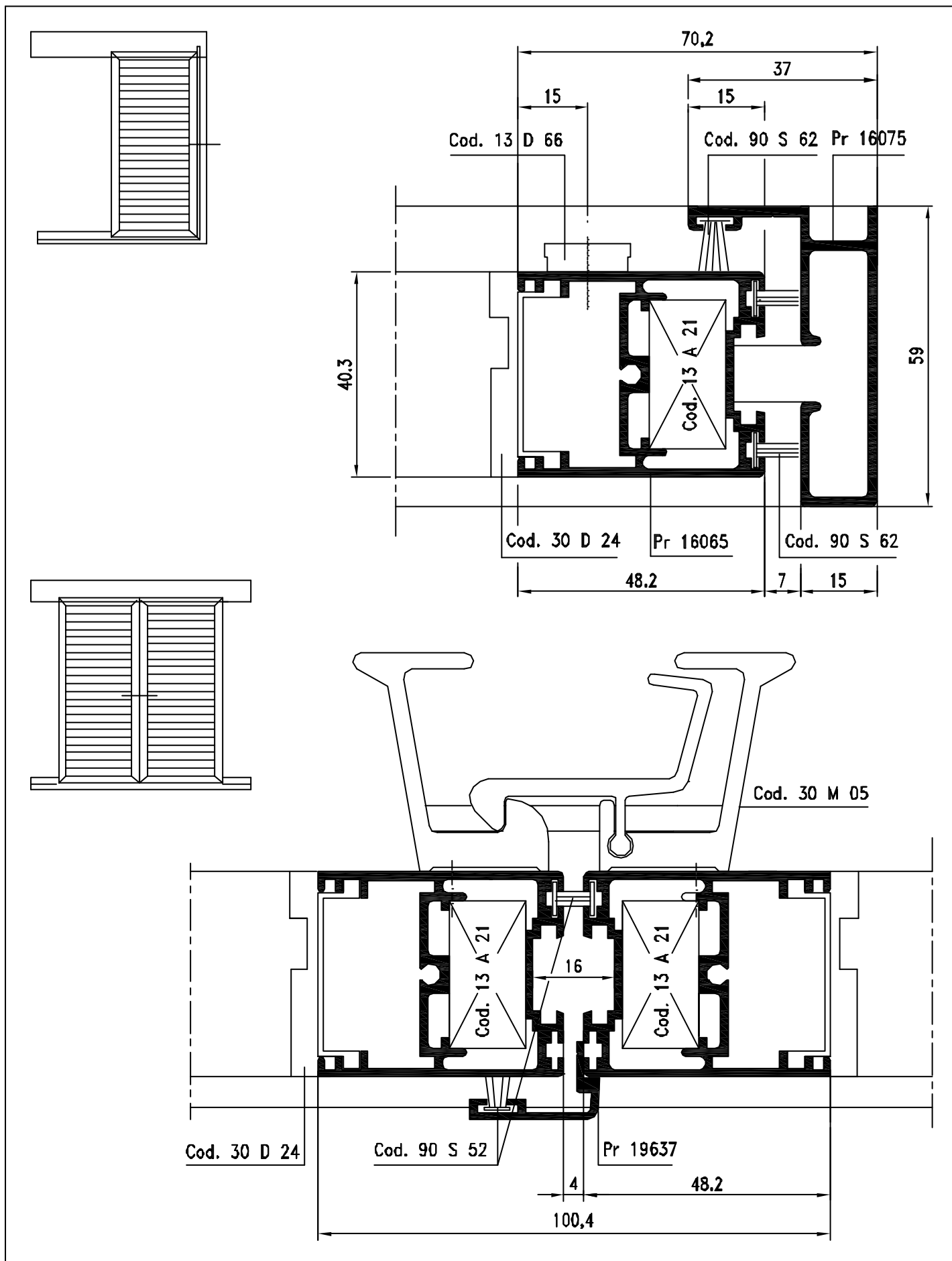

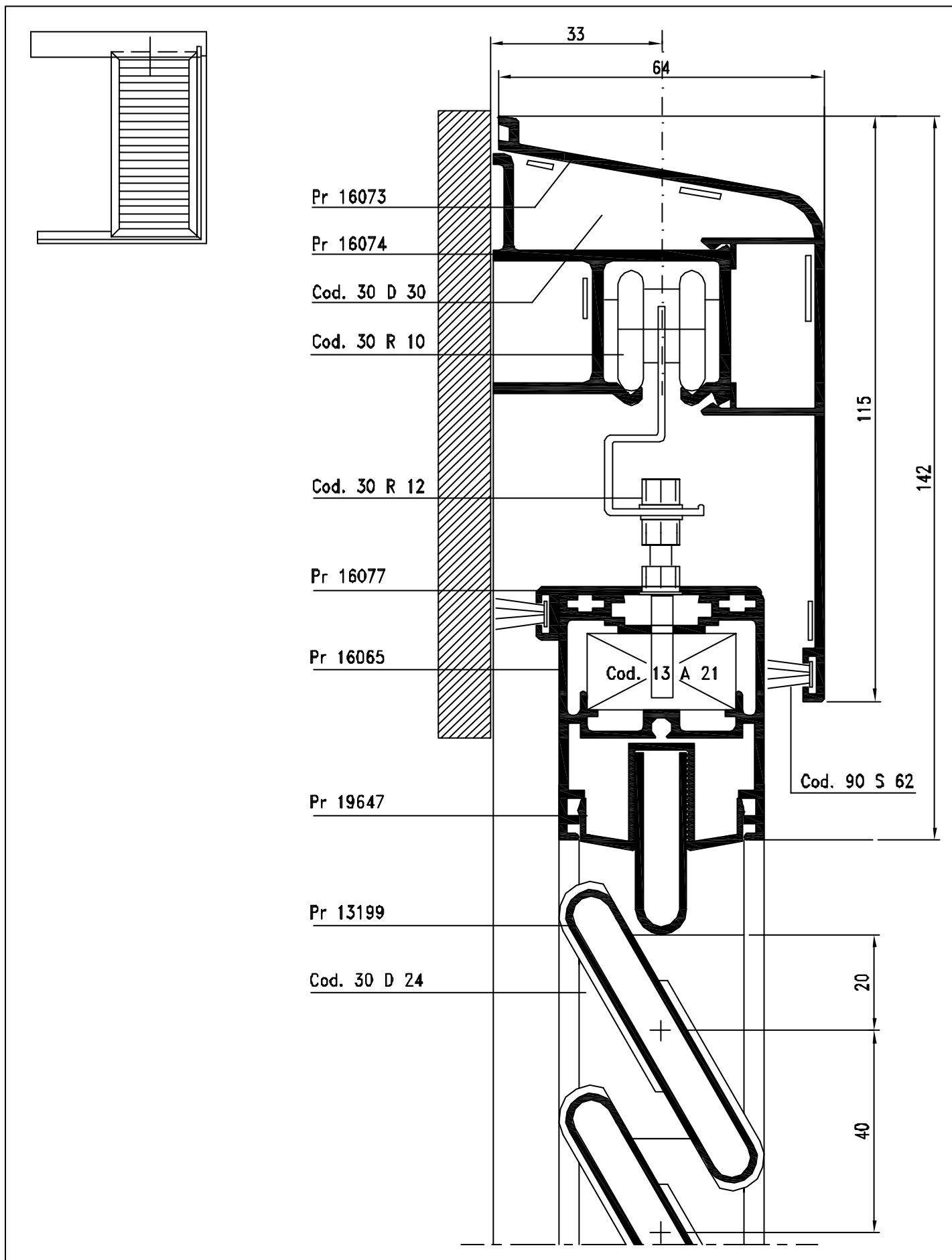

SCHEMA APPLICAZIONE LAMELLE FISSE APERTE

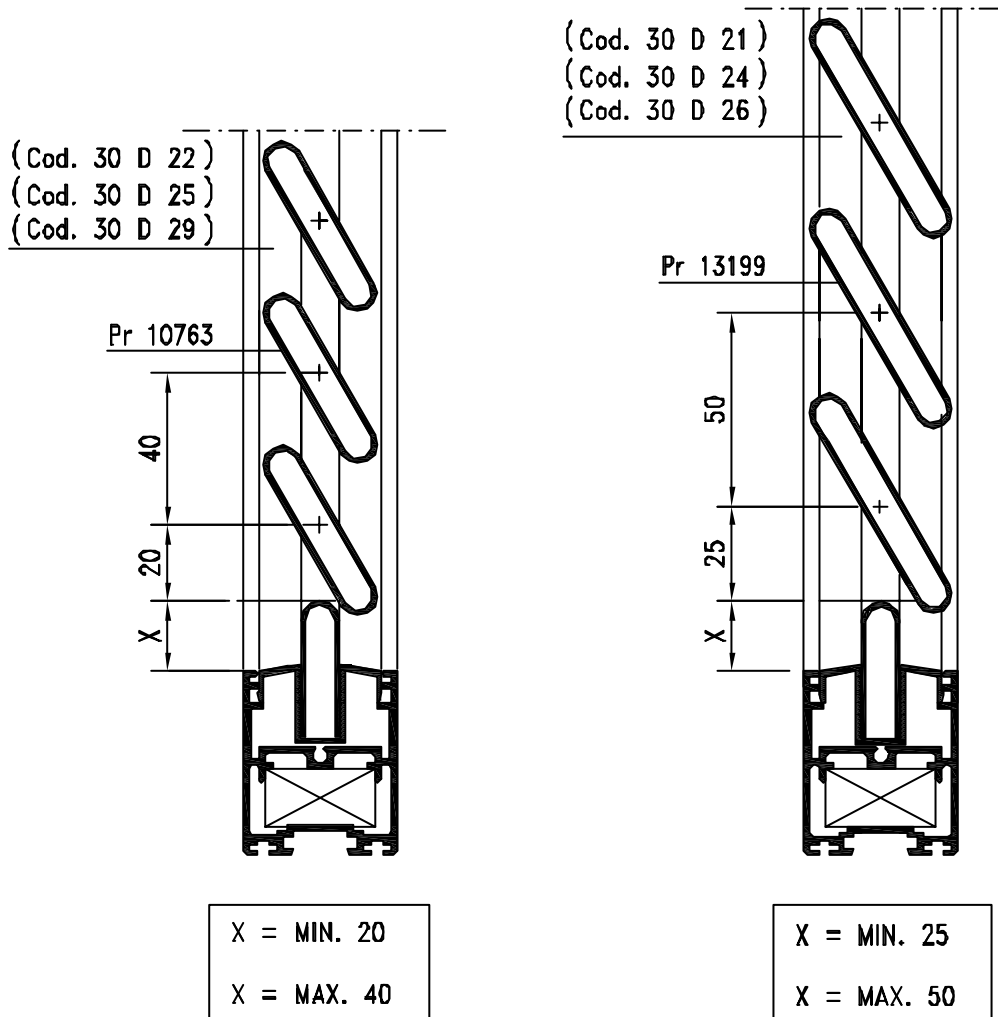
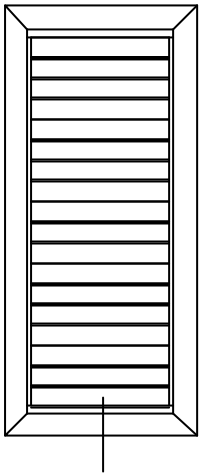

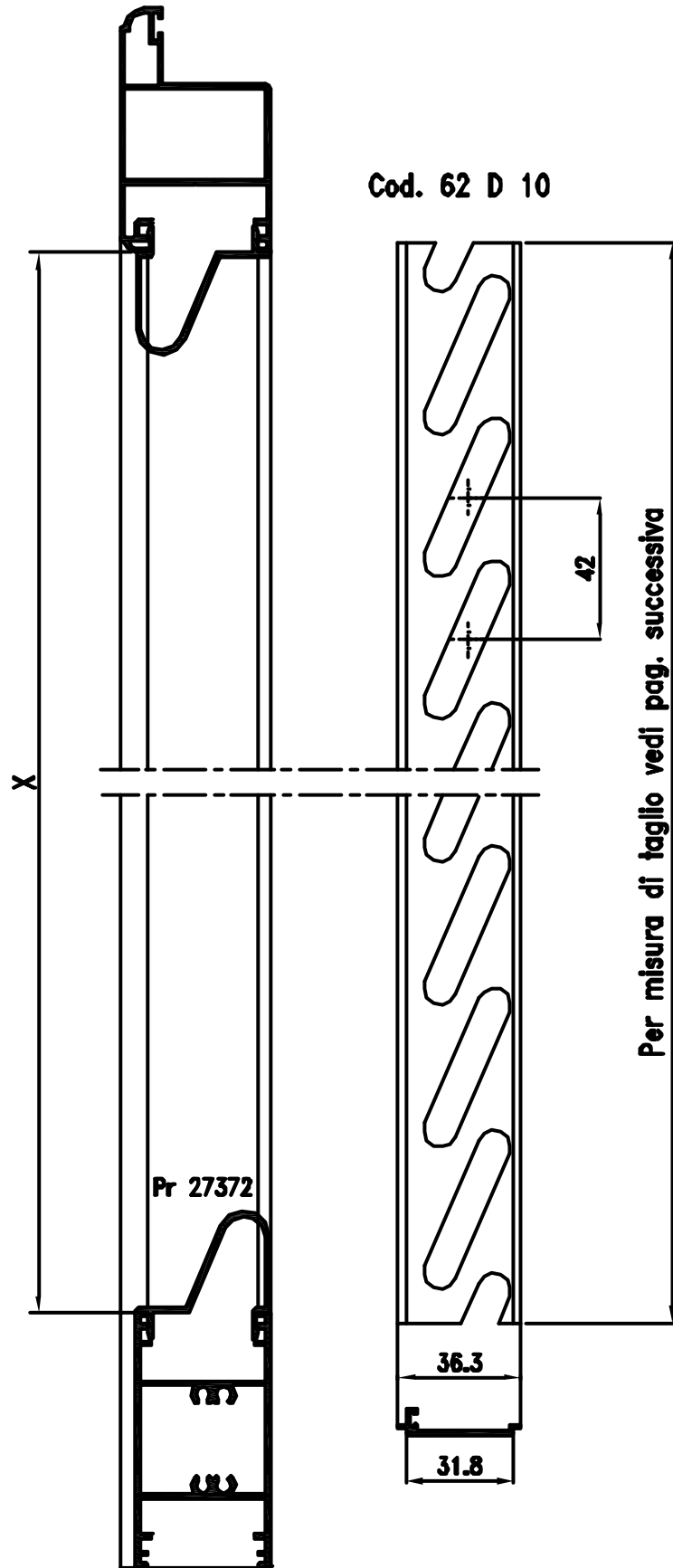

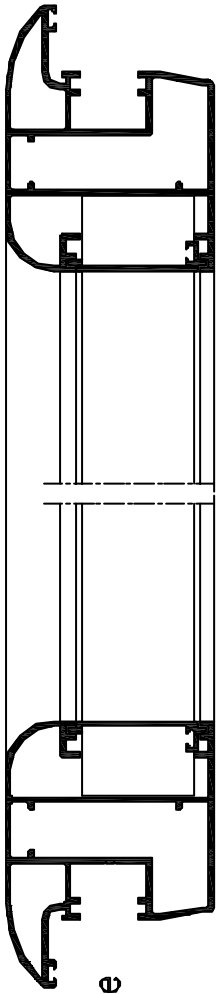

Sezione orizzontale

Sezioni verticali

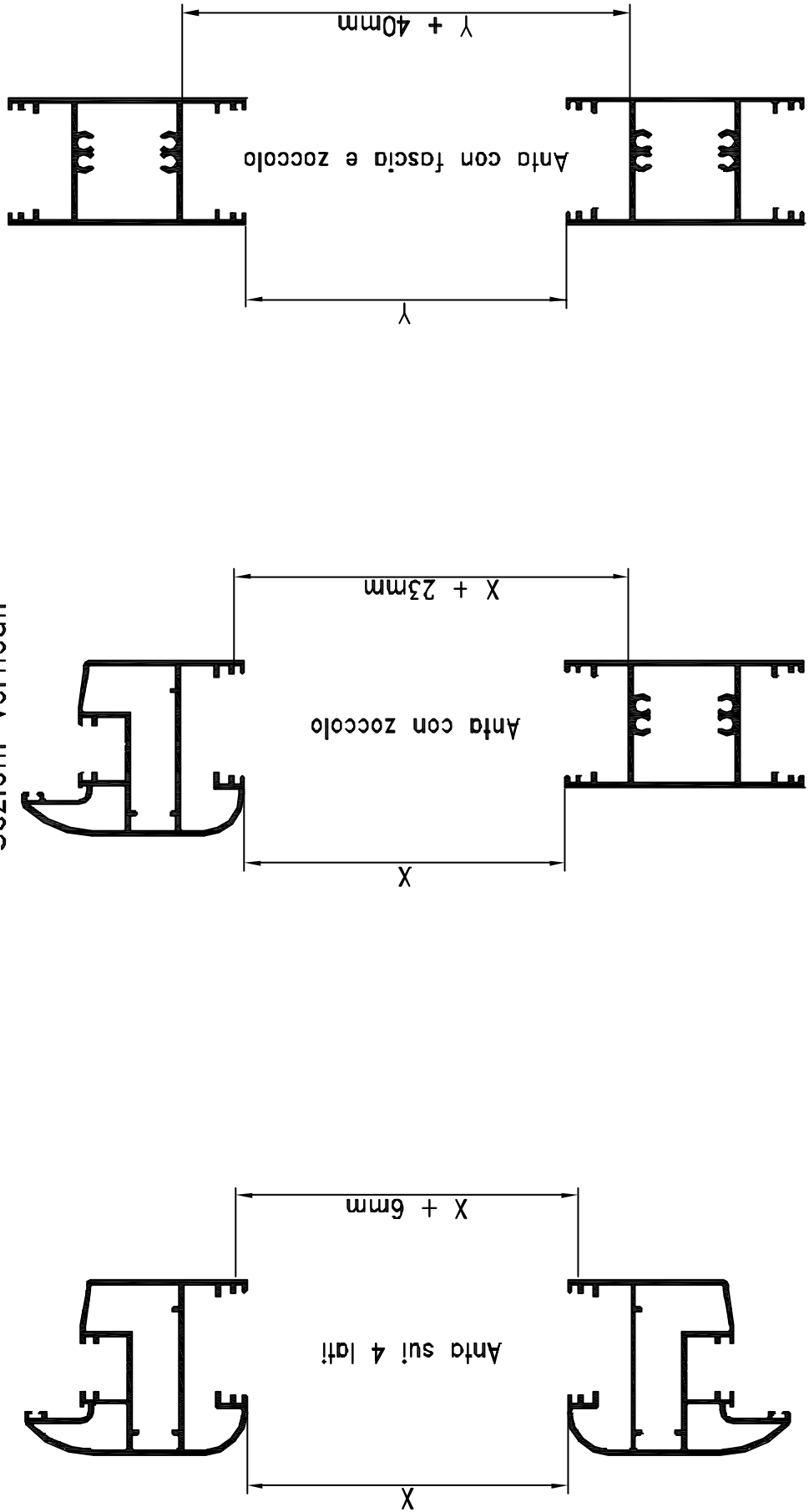

Taglio portalamelle pretranciata - Cod. 62 D 10

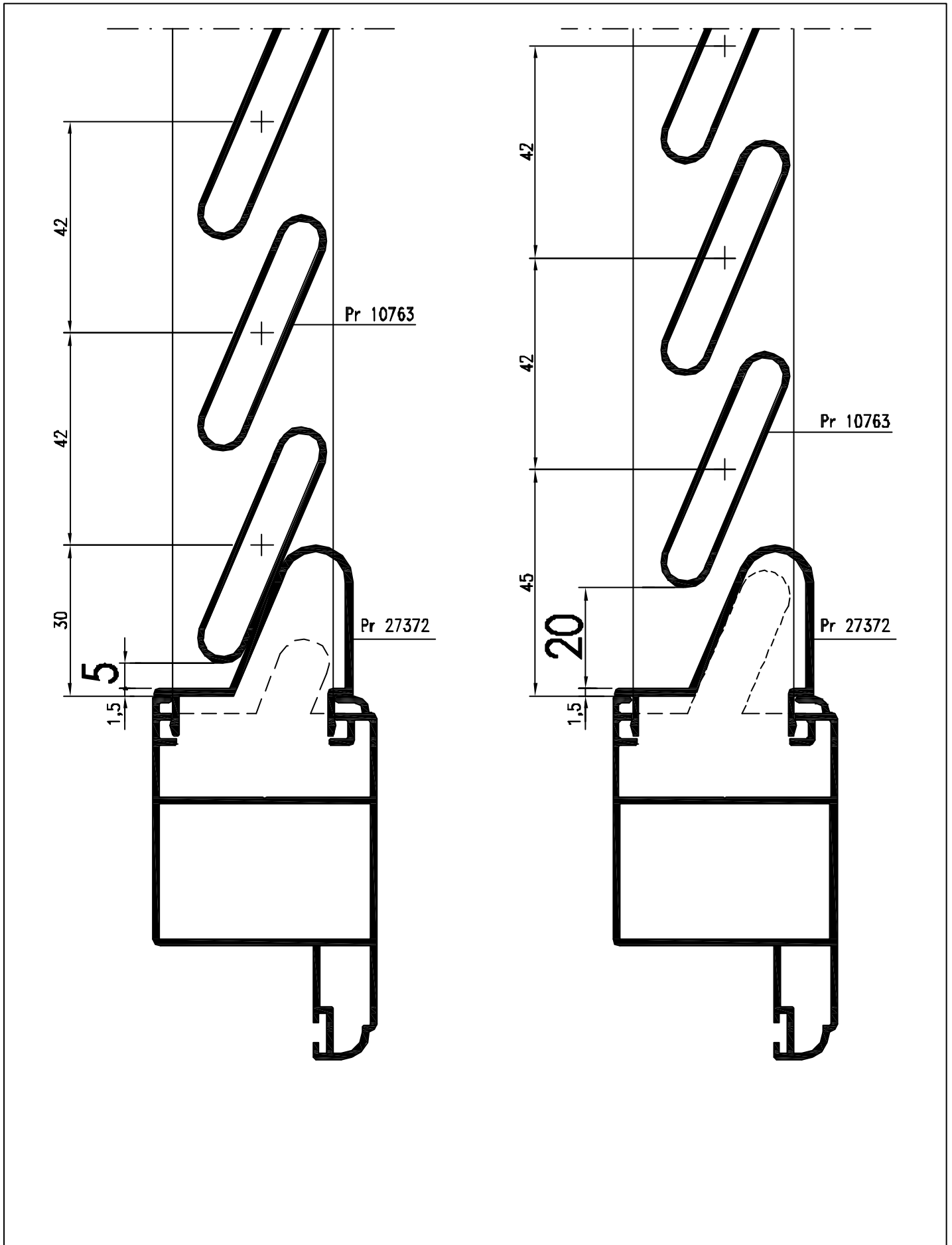

LAMELLE FISSE APERTE

per Pr 27366

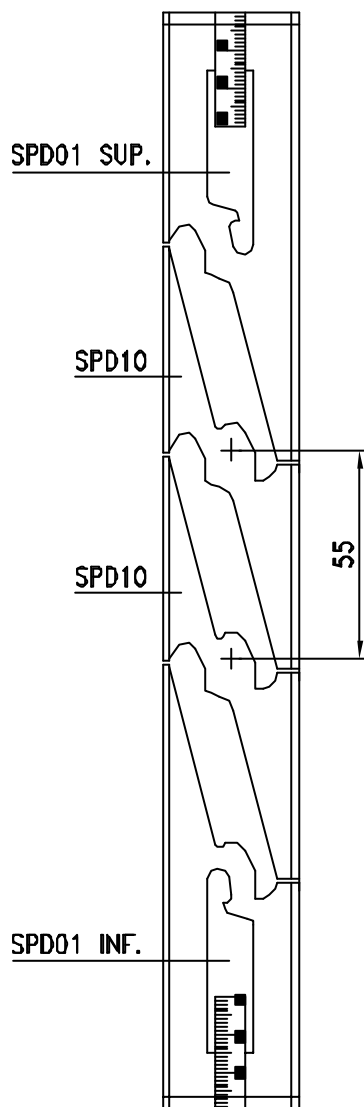

per Pr 27367
per Pr 27368

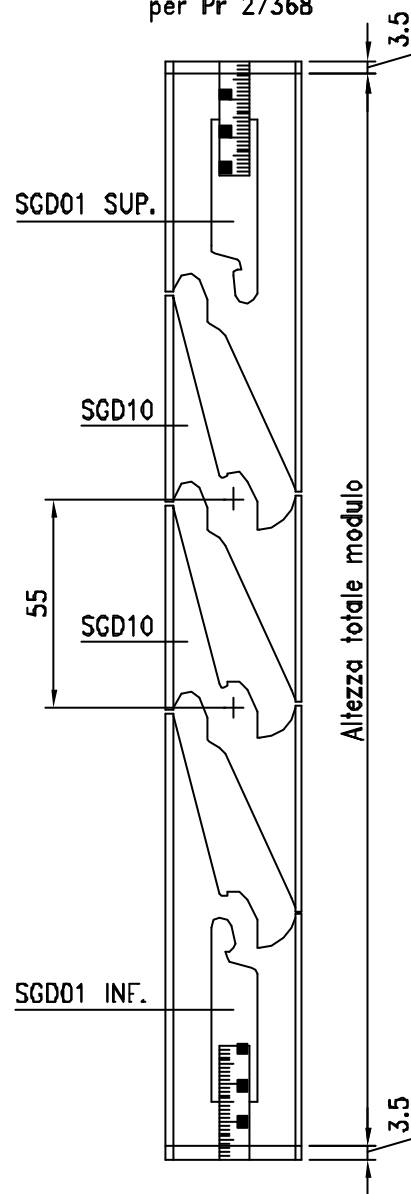

DOMAL SUNNY
Sistemi orientabili
Persiane lamelle fisse aperte

DESCRIZIONE	ALTEZZA TOTALE MODULO	N° LAMELLE
H modulo completo selle e compensatori	447	6
H modulo completo selle e compensatori	502	7
H modulo completo selle e compensatori	557	8
H modulo completo selle e compensatori	612	9
H modulo completo selle e compensatori	667	10
H modulo completo selle e compensatori	722	11
H modulo completo selle e compensatori	777	12
H modulo completo selle e compensatori	832	13
H modulo completo selle e compensatori	887	14
H modulo completo selle e compensatori	942	15
H modulo completo selle e compensatori	997	16
H modulo completo selle e compensatori	1052	17
H modulo completo selle e compensatori	1107	18
H modulo completo selle e compensatori	1162	19
H modulo completo selle e compensatori	1217	20
H modulo completo selle e compensatori	1272	21
H modulo completo selle e compensatori	1327	22
H modulo completo selle e compensatori	1382	23
H modulo completo selle e compensatori	1437	24
H modulo completo selle e compensatori	1492	25
H modulo completo selle e compensatori	1547	26
H modulo completo selle e compensatori	1602	27
H modulo completo selle e compensatori	1657	28
H modulo completo selle e compensatori	1712	29
H modulo completo selle e compensatori	1767	30

FORMULA PER IL TAGLIO DEI COMPENSATORI

Cod. SG D 01 - Cod. SP D 01

$$\frac{\text{Altezza totale modulo} - \text{luce anta}}{2} = \text{quota di taglio dei compensatori}$$

QUOTA DI TAGLIO DELLE LAMELLE

Luce anta + 16 mm.

Cod. SU K 97

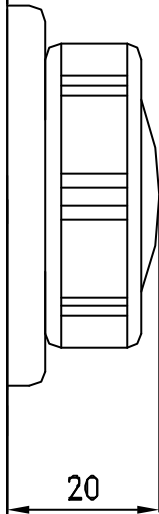
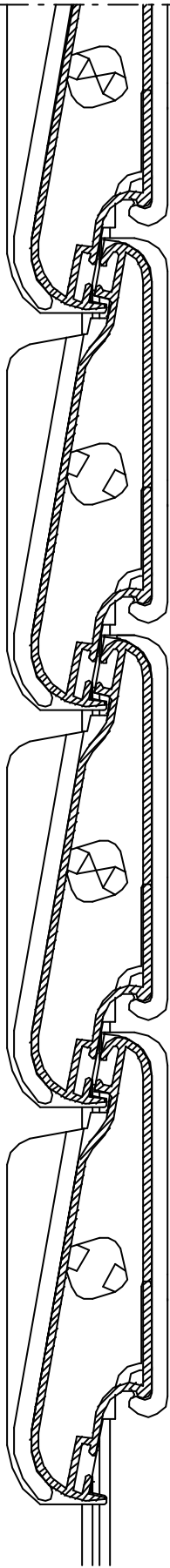

20

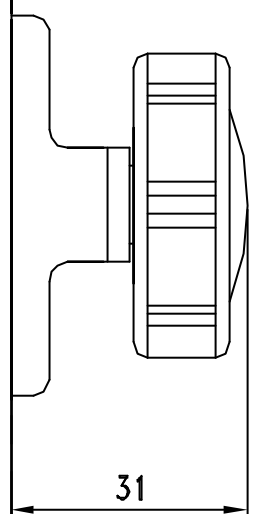
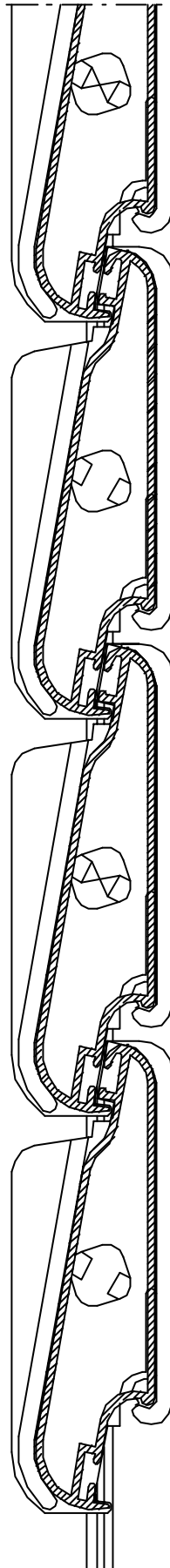

31

Nei caso di persiane con più di 20 lamelle, sono necessarie 2 maniglie "GRIP",
che possono essere applicate ad un unico KIT eseguendo la lavorazione indicata.

SU K 98 (Dx)
SU K 99 (Sx)

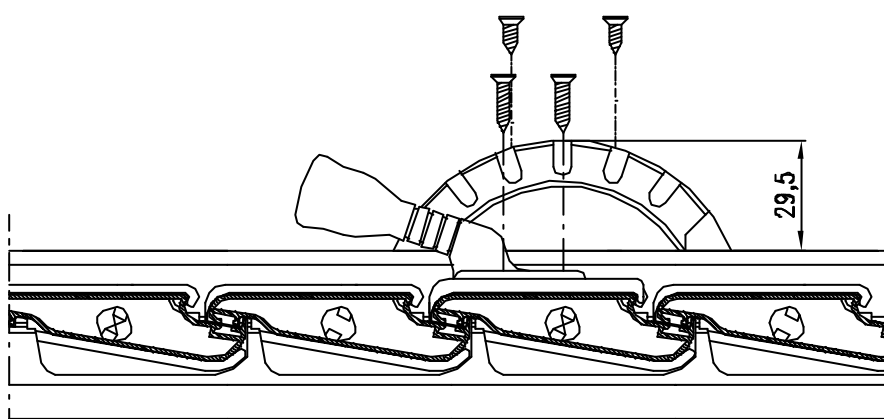
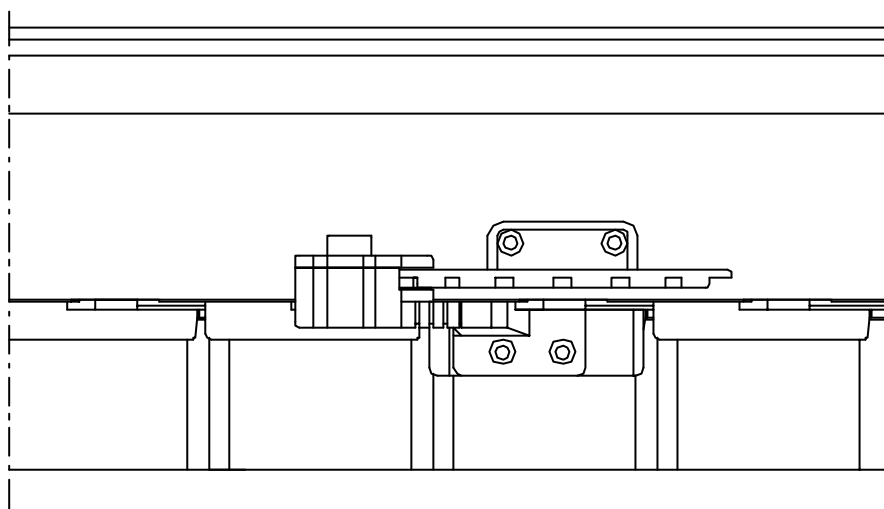
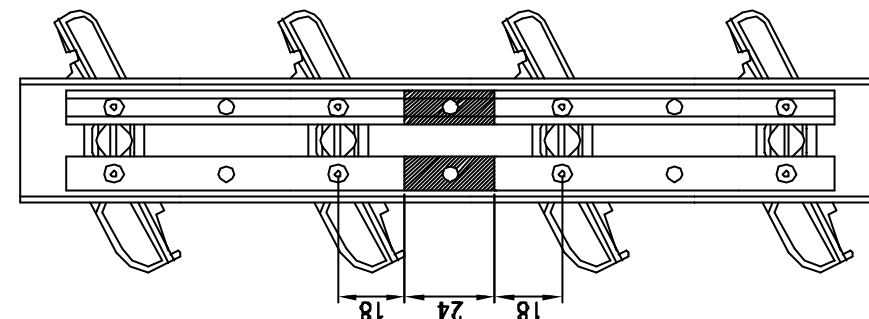

LAMELLE FISSE CHIUSE E LAMELLE ORIENTABILI

$$X = \mathbf{p} + 31$$

p = misura di posizionamento dei compensatori (SUD90)*

$$\mathbf{p} = \frac{\text{LUCE ANTA} - \text{Misura Kit}}{2} - 31$$

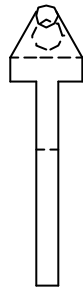

- Se la quota non risulterà intera, arrotondare alla misura finita.
ES. : X=24.5mm compensare nella parte inferiore a 25mm e nella parte superiore a 24mm.
- Il particolare illustrato qui a fianco dovrà essere aggiunto nel tappo compensatore quando $X > 17\text{mm}$, con funzione di oscuramento totale.

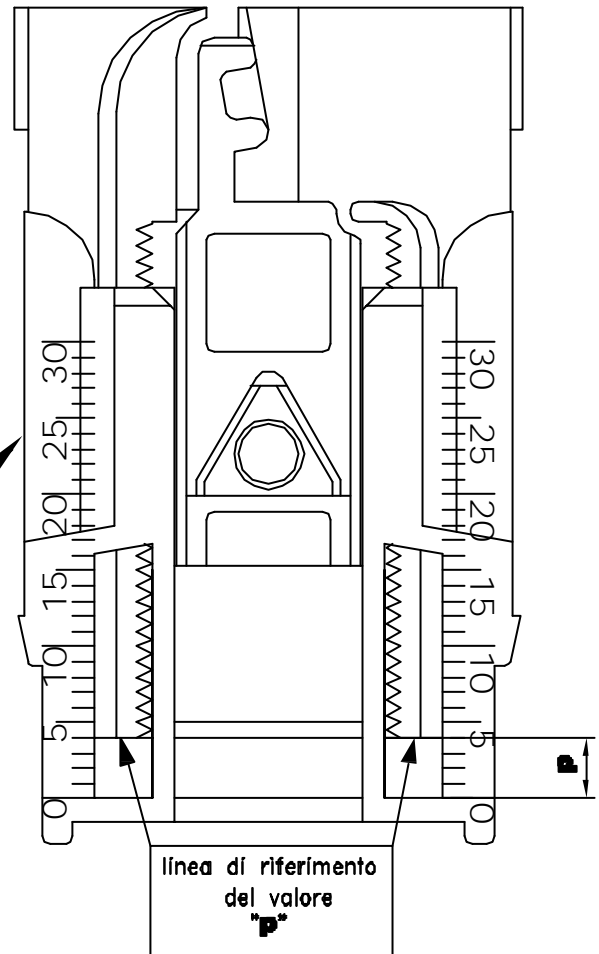
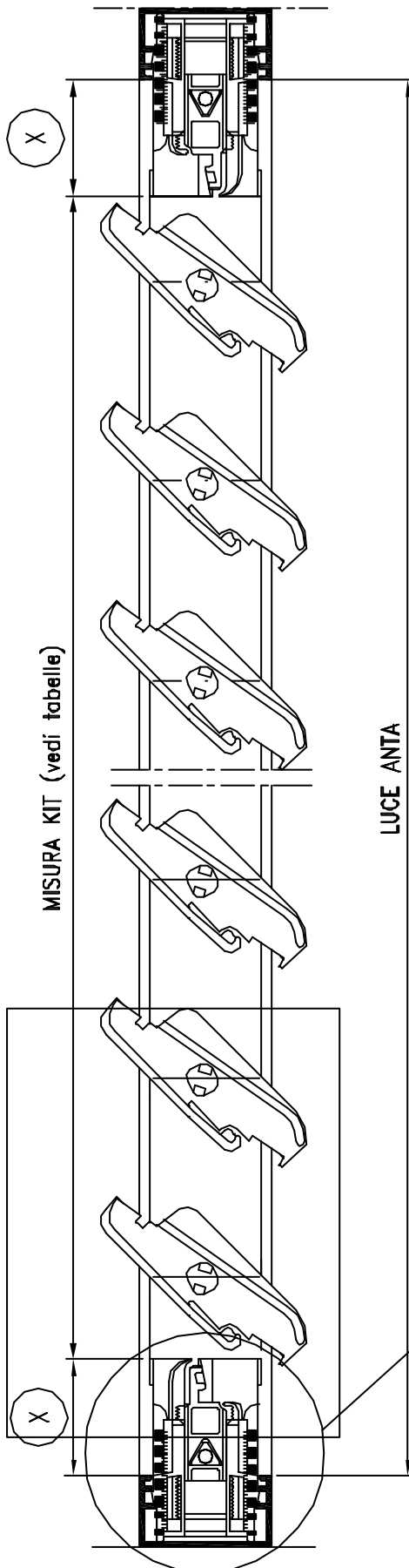

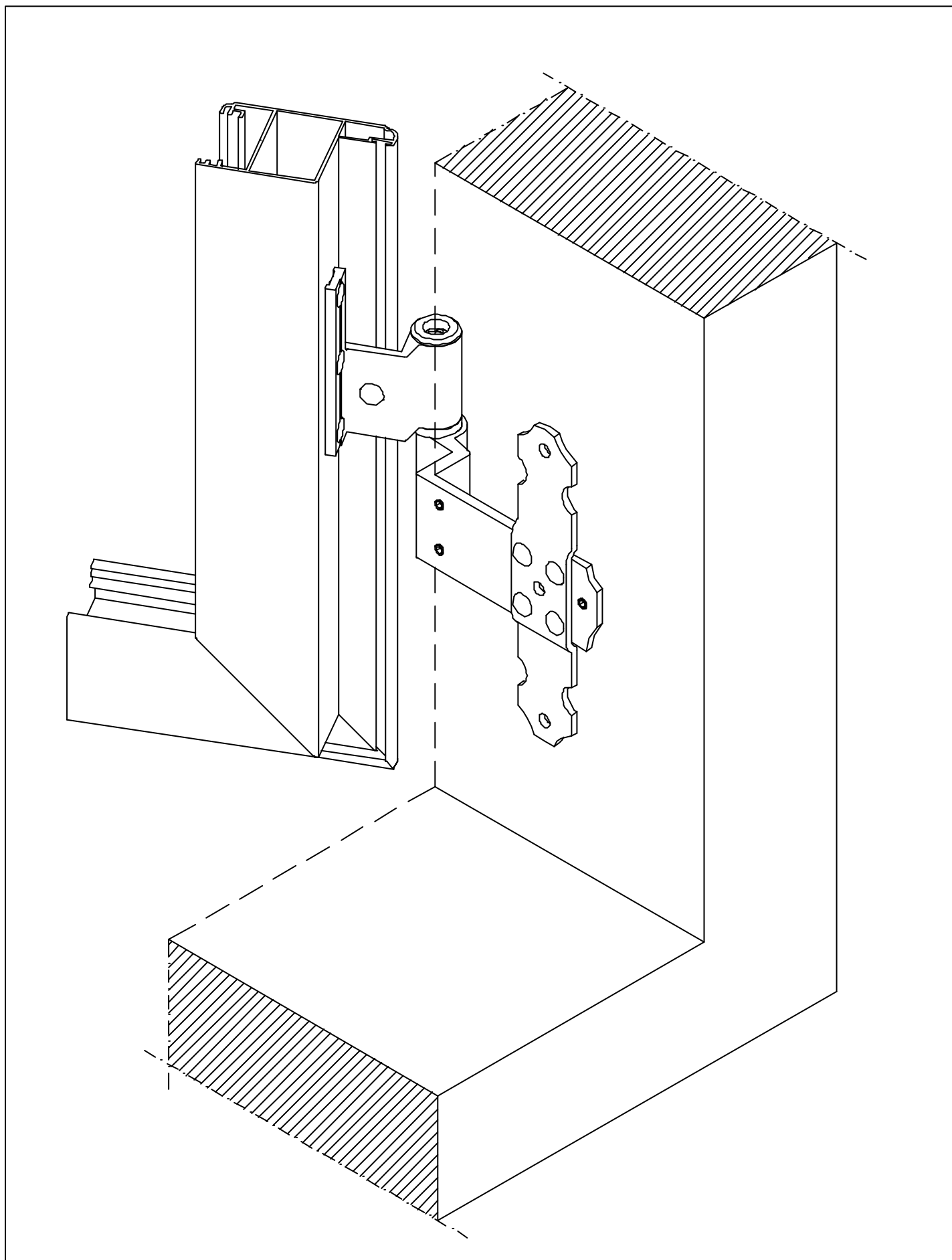

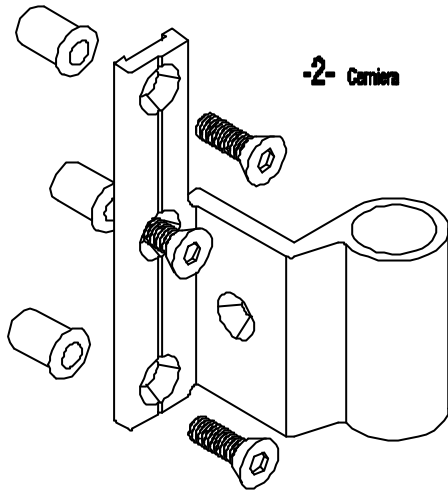

-2- Cerniera

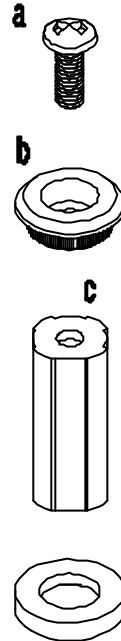

-4- COD. 308116

Kit "Take-Down" applicabile al perno eccentrico garantendo l'antifilamento dell'anta. Composto da:
 a) Vite TBBcr MSX14 Nerinox
 b) Tappo di sicurezza Ø20x7 in OTTONE ZINCATO NERO
 c) Buccola per perno cardine Ø18

-5- KIT FISSAGGIO ANTA COD. 308114

n° 20 inserti alluminio TP-C
 n° 20 Viti MSd4 Nerinox

-3- PERNO INOX ECCENTRICO

Regolazione verticale e orizzontale

-6- LASTRINA PER REGISTRAZIONE

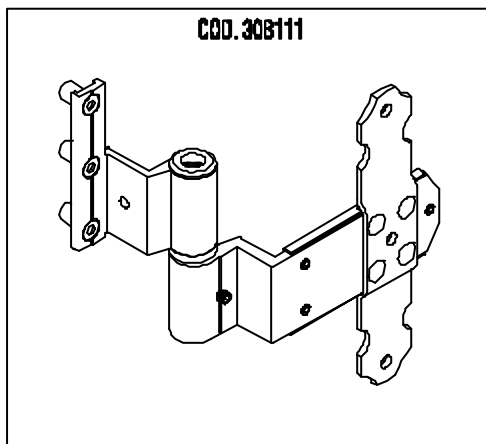

COD. 308111

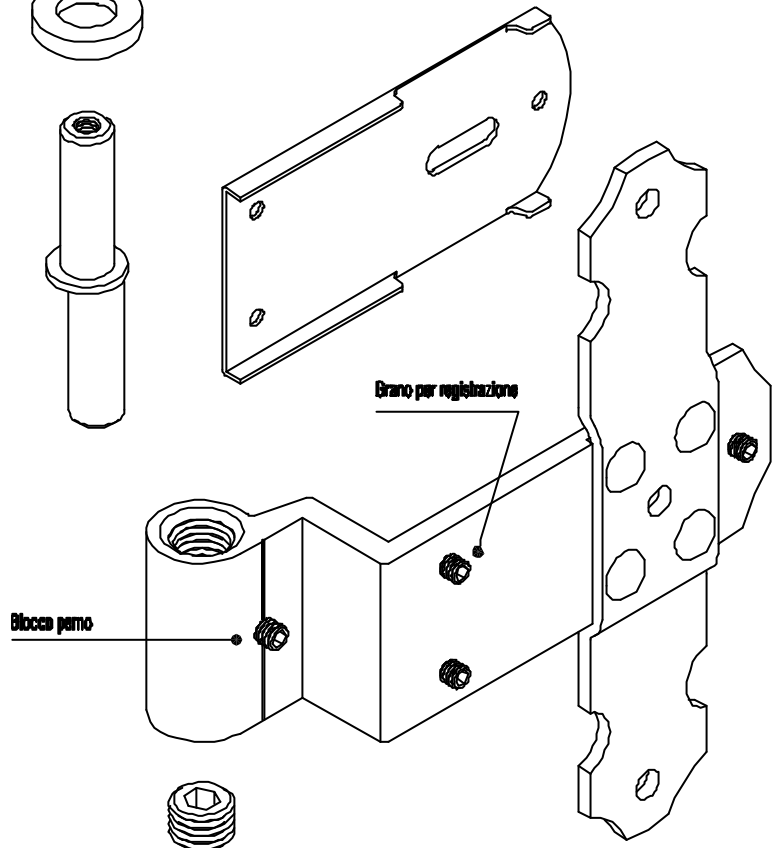

-1- Cardine da interno per pannello

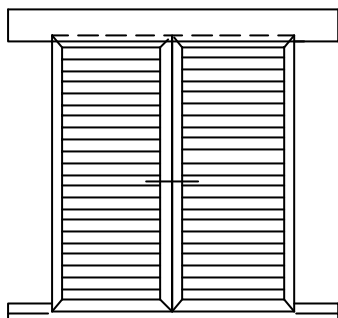

INTERASSE DI FORATURA
MANIGLIA CENTRALE SUNNY SCORREVOLE
Cod. 30 M 01

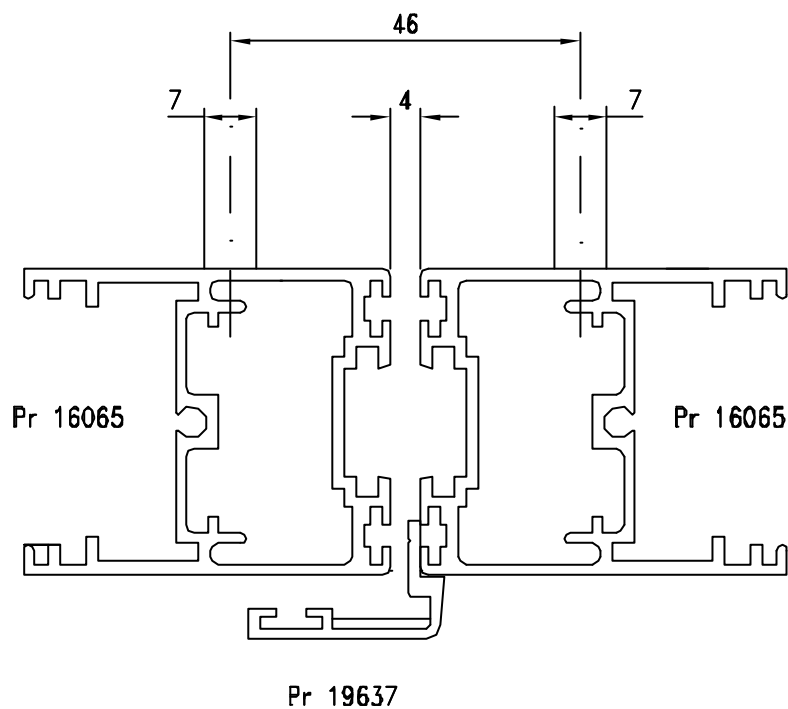

NB. Nelle confezioni sono inserite viti metriche di fissaggio con inserti filettati.
Possono essere sostituiti con viti autofilettanti adeguando i fori di fissaggio.

Massima distanza tra i profilati di sostegno:
Dilatazione = 0mm

NB: E' necessario fissare il tappo
Cod. 30D300 come descritto nel
disegno, per evitare sfilamento
dello stesso, dovuti a dilatazioni
dei materiali

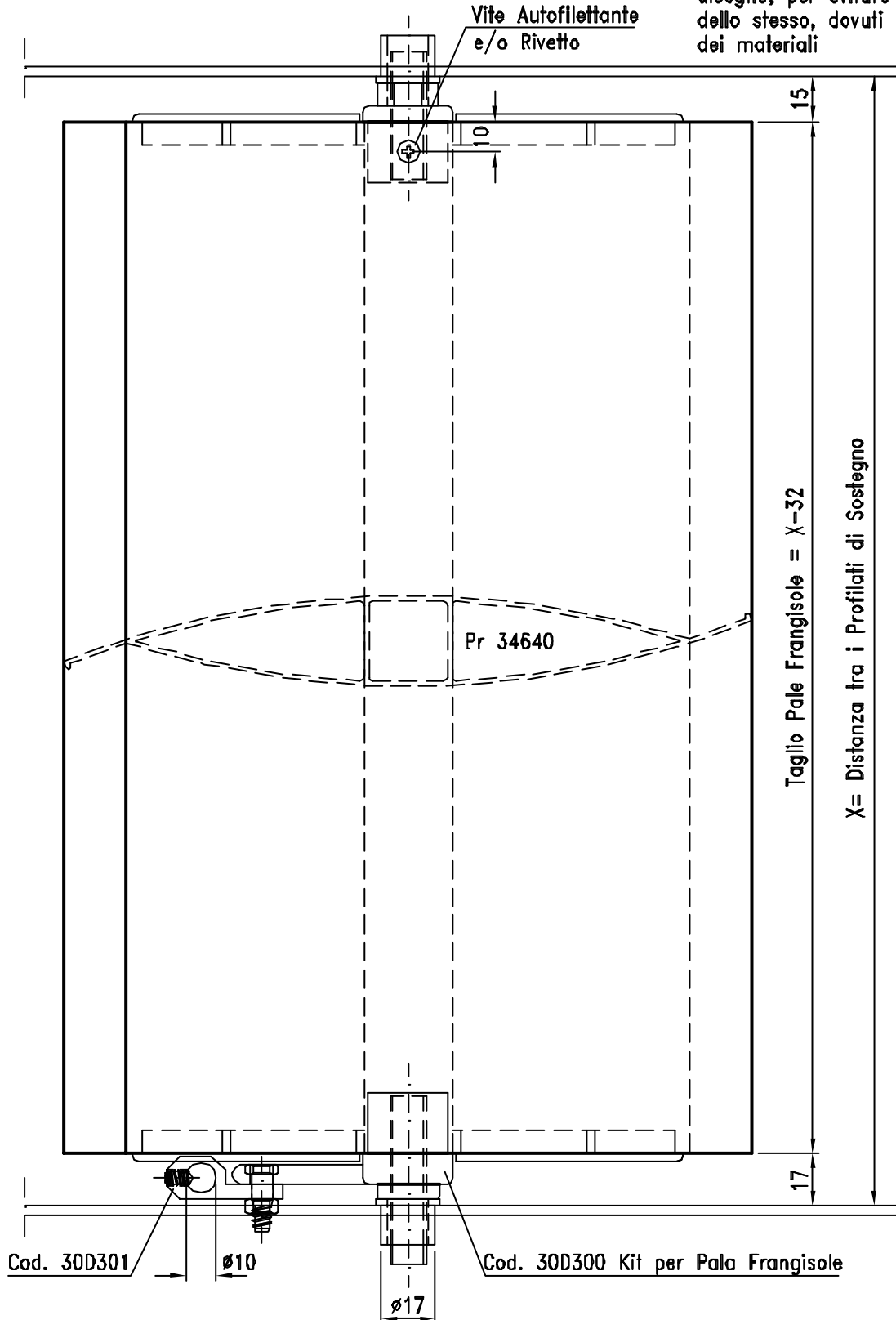

Massima distanza tra i profilati di sostegno:
Dilatazione = 4mm

NB: E' necessario fissare il tappo
Cod. 30D300 come descritto nel
disegno, per evitare sfilamento
dello stesso, dovuti a dilatazioni
dei materiali

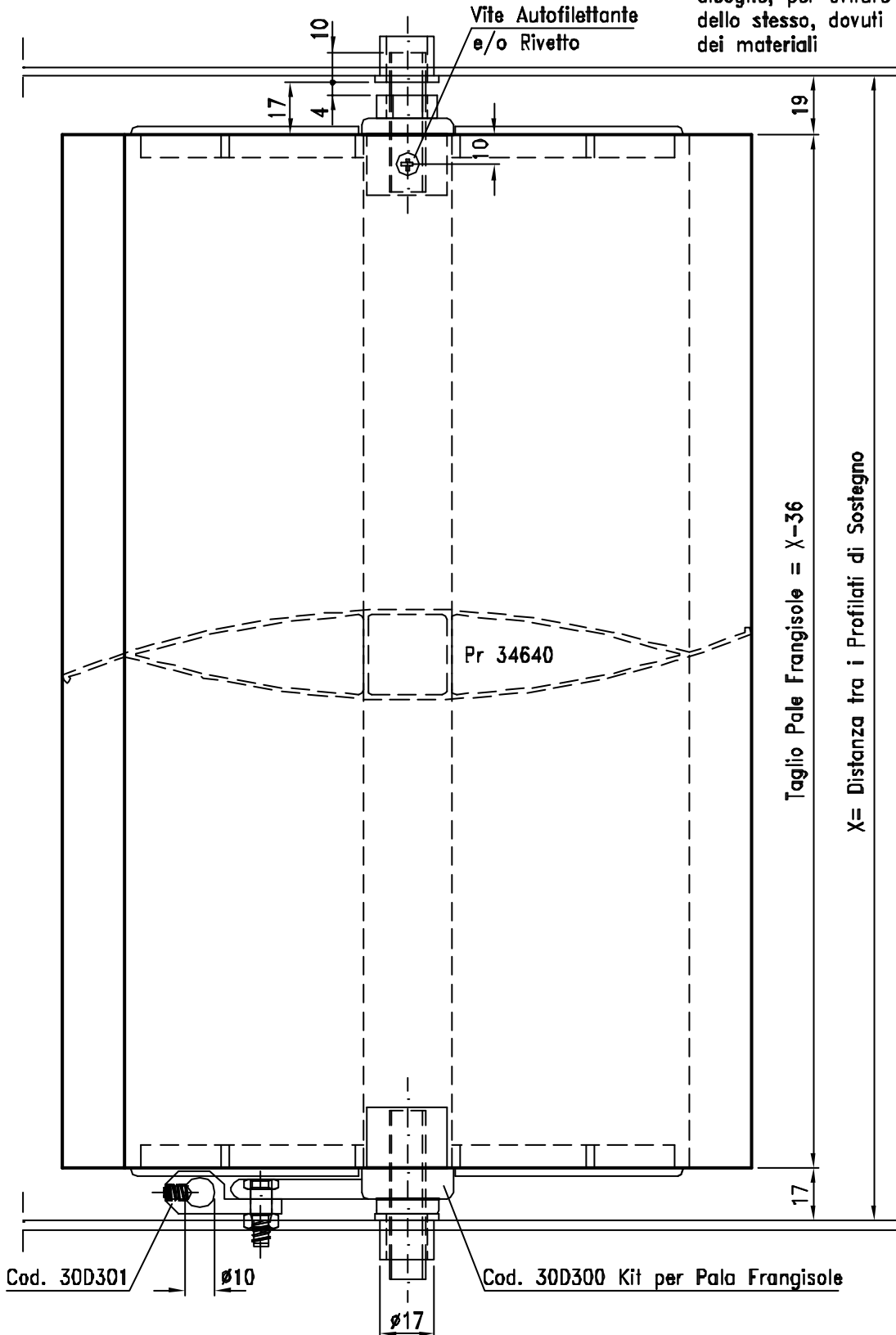

Massima distanza tra i profilati di sostegno:
Dilatazione = 8mm

NB: E' necessario fissare il tappo
Cod. 30D300 come descritto nel
disegno, per evitare sfilamento
dello stesso, dovuti a dilatazioni
dei materiali

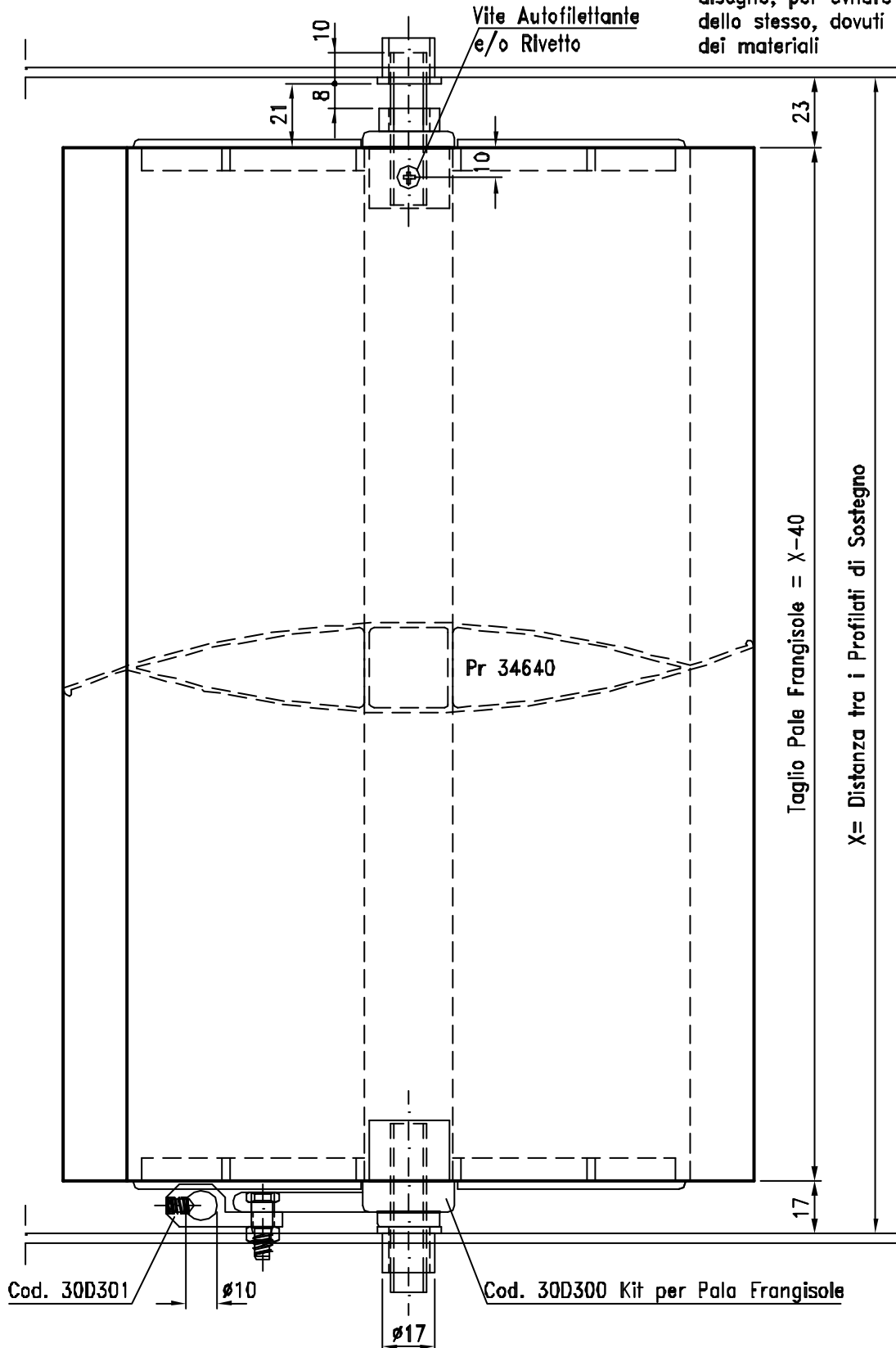

NB: È necessario fissare il tappo
Cod. 30D300 come descritto nel
disegno, per evitare sfilamento
dello stesso, dovuti a dilatazioni
dei materiali

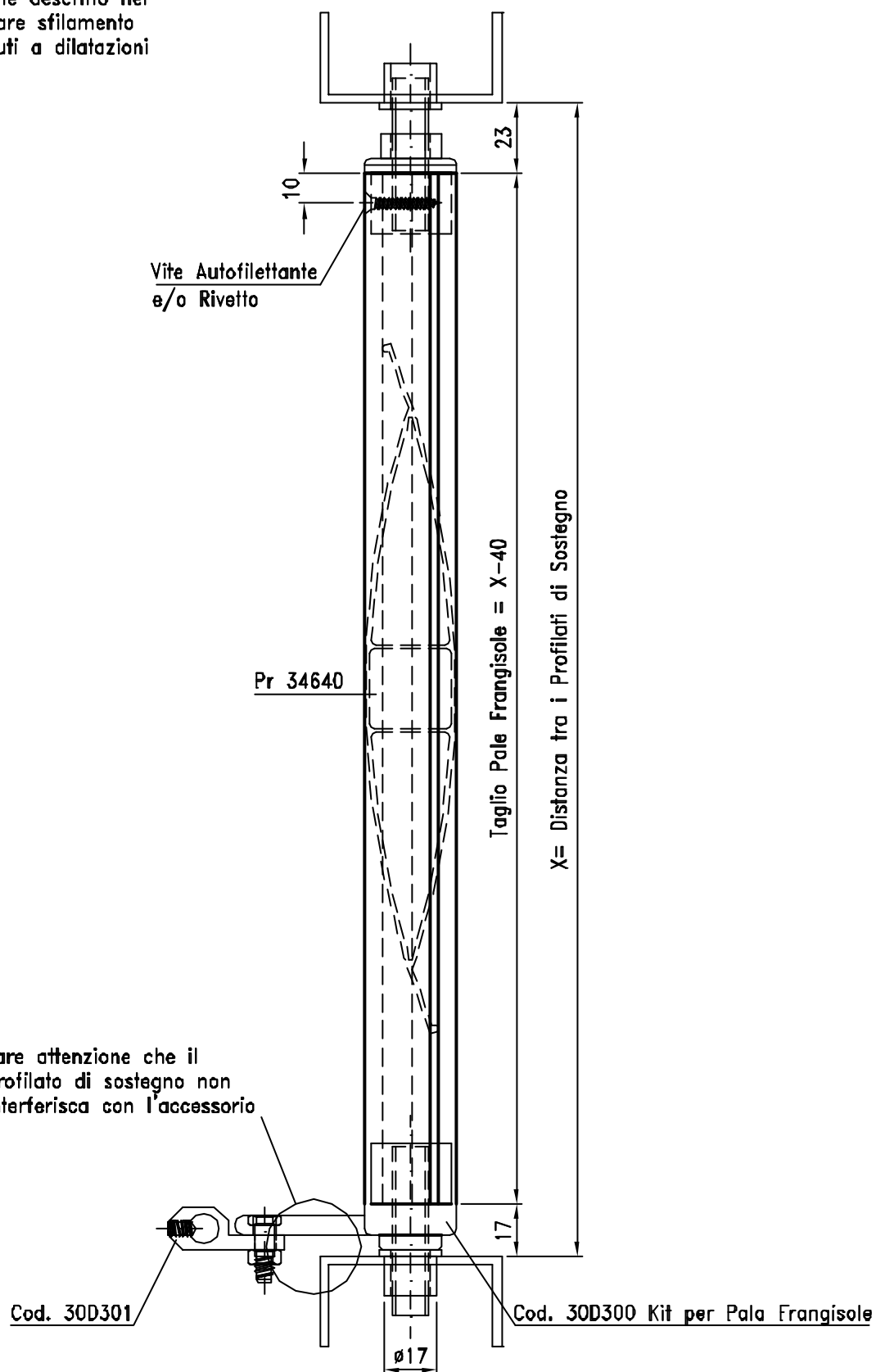

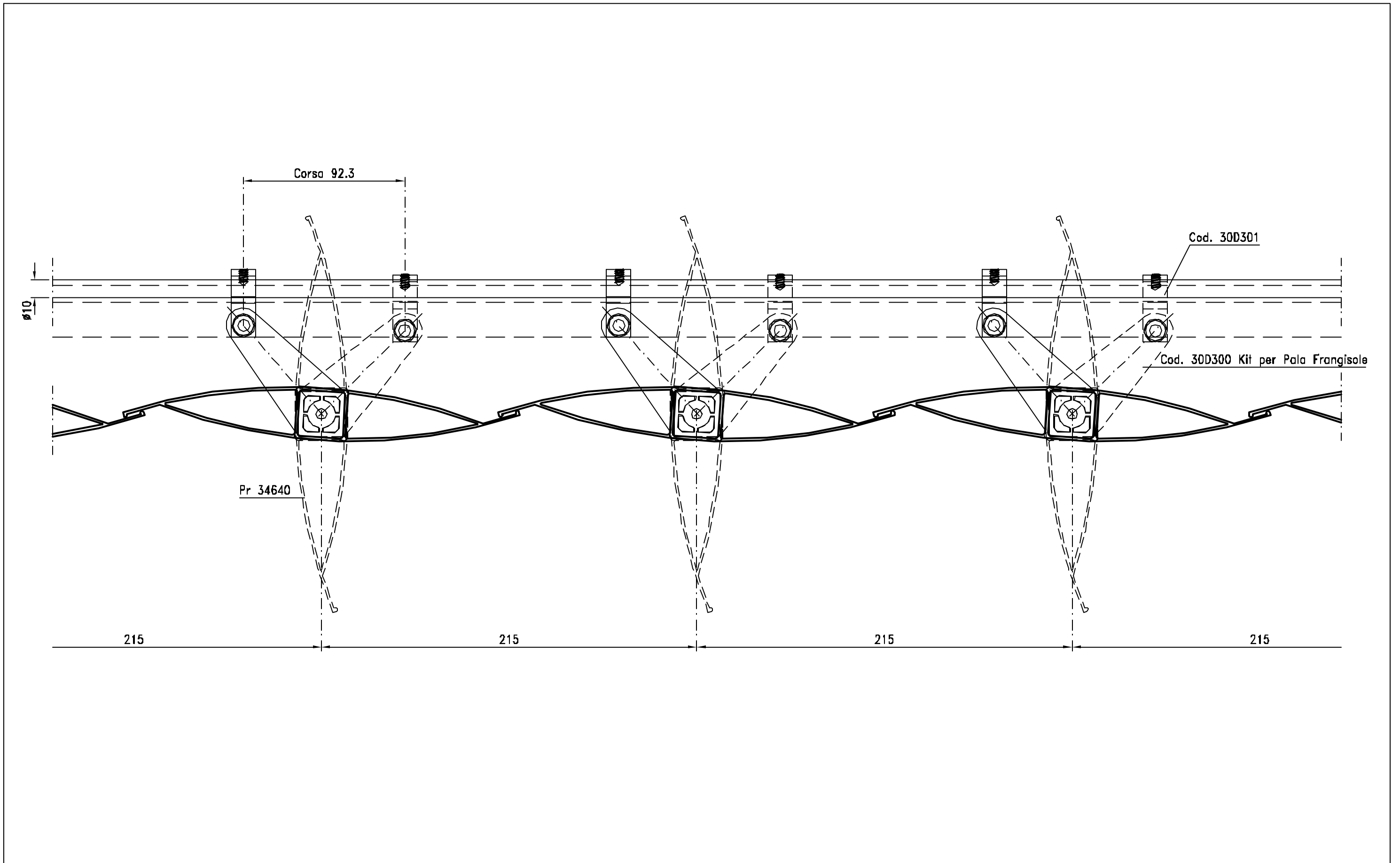





DOMAL SUNNY FIORENTINA

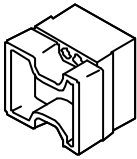
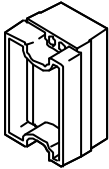

INDICE SUNNY FIORENTINA

DESCRIZIONE	da pag.	a pag.
INDICE		131
ACCESSORI	133	155
SAGOMARIO PROFILATI	157	159
PROFILATI 1:1	161	165
SCHEMI E DISTINTE	167	170
SEZIONI 1:1	171	174

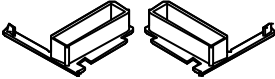
ACCESSORI	CODICE	COLORE	DESCRIZIONE	MATER.	CONFEZ.
	04 A 21	GREZZO	SQUADRETTA PRESSOFUSA A SCATTO	ALLUMINIO	PEZZI 250
	04 A 24	GREZZO	SQUADRETTA AD ANGOLAZIONE VARIABILE	ALLUMINIO	PEZZI 20
	10 H 38	GREZZO	SQUADRETTA DI ALLINEAMENTO	ALLUMINIO	PEZZI 200
	15 A 14	GREZZO	SQUADRETTA ESTERNA PER Pr 27538	ALLUMINIO	PEZZI 100
	15 A 29	GREZZO	SPINA CON MANICO PER Cod. 15 A 46	ALLUMINIO	PEZZI 1000
	15 A 46	GREZZO	SQUADRETTA PER Pr 27538	ALLUMINIO	PEZZI 200
	30 A 10	GREZZO	SQUADRETTA PER Pr 26238 - 26239	ALLUMINIO	PEZZI 250
	30 B 90	GREZZO VERDE GRINZ MARRONE GRINZ	CERNIERA PER Pr 26238 - 26239	ALLUMINIO	PEZZI 50

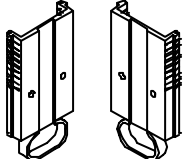
ACCESSORI	CODICE	COLORE	DESCRIZIONE	MATER.	CONFEZ.
	30 D 04	NERO	TAPPO PER Pr 16013	NYLON	PEZZI 50
	30 D 05	NERO	TAPPO PER Pr 16012	NYLON	PEZZI 50
	30 D 06	NERO RAL 1013 RAL 6005 RAL 7100 RAL 7200 RAL 7300 RAL 8001P RAL 8017 RAL 9010	TAPPO CHIUDI TUBOLARITA' PER PROFILATO ROMPITRATTA Pr.27374	NYLON	PEZZI 20
	30 D 17	NERO	TAPPI CHIUDI TUBOLARITA' PER Pr 21688	NYLON	PEZZI 50
	30 D 21	RAL6005 RAL9005	SELLA REVERSIBILE PER Pr 13199	NYLON	PEZZI 500
	30 D 22	RAL1013 RAL6005 RAL8017 RAL9005 RAL9010	SELLA REVERSIBILE PER Pr 10763-50013	NYLON	PEZZI 500
	30 D 23	NERO	COMPENSATORI PER Pr 13199 GELOSIA A LAMELLE Fisse 30	NYLON	PEZZI 100

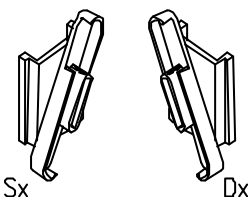
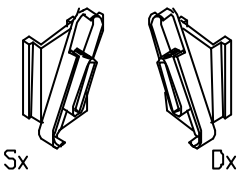
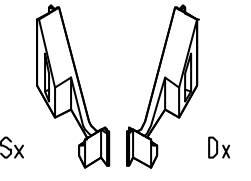
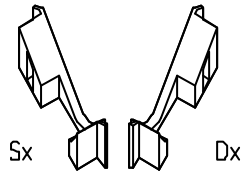
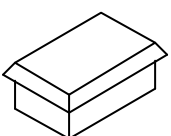
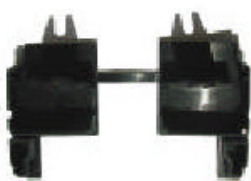
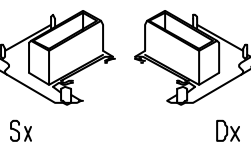
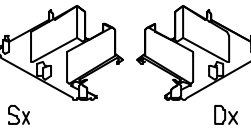
ACCESSORI	CODICE	COLORE	DESCRIZIONE	MATER.	CONFEZ.
	30 D 24	NERO	TAPPI DX E SX PER Pr 13199 GELOSIA A LAMELLE FISSE 30°	NYLON	COPPIE 50
	30 D 29	NERO	TAPPI PER Pr 10763 GELOSIA A LAMELLE FISSE 30°	NYLON	COPPIE 100
	30 D 41	NERO	MEZZE SELLE PER Cod. 30 D 21	NYLON	COPPIE 50
	30 D 42	NERO	MEZZE SELLE PER Cod. 30 D 22	NYLON	COPPIE 50
	30 D 72	NERO	TAPPO CHIUDI TUBOLARITA' INFERIORE PER STULP Pr 27357	NYLON	PEZZI 250
	30 D 73	NERO	TAPPO CHIUDI TUBOLARITA' INFERIORE PER ANTA Pr 27359	NYLON	PEZZI 50
	30 D 75	NERO	TAPPI CHIUDI TUBOLARITA' INFERIORE PER Pr. 26236-26240	NYLON	PEZZI 50
	30 D 76	NERO	TAPPI CHIUDI TUBOLARITA' INFERIORE PER Pr. 26235	NYLON	PEZZI 50

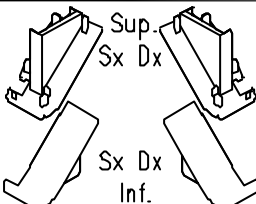
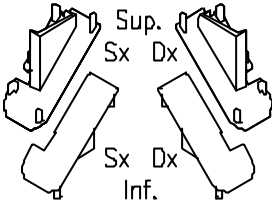
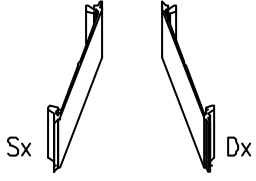
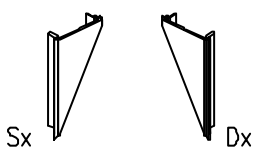
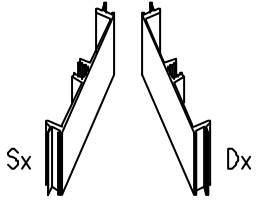
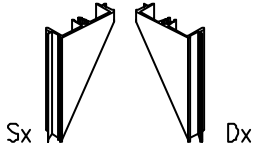
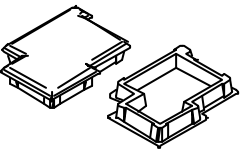
ACCESSORI	CODICE	COLORE	DESCRIZIONE	MATER.	CONFEZ.
	30 D 91	NERO	TAPPI SUPERIORI E INFERIORI PER Pr 26239	NYLON	COPPIE 25
	30 D 92	NERO	TAPPI SUPERIORI E INFERIORI PER Pr 26238	NYLON	COPPIE 25
	30 D A0	GREZZO ELETT. VERDE GRINZ MARRONE GRINZ	COPPIA SELLE PER Pr 26230	ALLUMINIO	COPPIE 100
	30 D B0	GREZZO ELETT. VERDE GRINZ MARRONE GRINZ	COPPIA COMPENSATORI PER Pr 26230	ALLUMINIO	COPPIE 50
	30 D C0	GREZZO ELETT. VERDE GRINZ MARRONE GRINZ	COPPIA SELLE PER Pr 27360	ALLUMINIO	COPPIE 100
	30 D D0	GREZZO ELETT. VERDE GRINZ MARRONE GRINZ	COPPIA COMPENSATORI PER Pr 27360	ALLUMINIO	COPPIE 50
	33 D 02	NERO	TAPPO CHIUDI TUBOLARITA' INFERIORE PER STULP Pr 24452	NYLON	PEZZI 100

ACCESSORI	CODICE	COLORE	DESCRIZIONE	MATER.	CONFEZ.
	30B110D 30B110S	GREZZO RAL9005 RAL8017 RAL6005	CARDINI DX-SX PER ANTA STORICA FISSAGGIO INTERNO	ALLUMINIO	PEZZI 20Dx PEZZI 20Sx
	30B111D 30B111S	GREZZO RAL9005 RAL8017 RAL6005	CARDINI DX-SX PER ANTA STORICA FISSAGGIO INTERNO CON PERNO REGOLABILE	ALLUMINIO	PEZZI 20Dx PEZZI 20Sx
	30B112	GREZZO RAL9005 RAL8017 RAL6005	CARDINE PER ANTA STORICA FISSAGGIO ESTERNO	ALLUMINIO	PEZZI 20
	30B113	GREZZO RAL9005 RAL8017 RAL6005	CARDINE PER ANTA STORICA FISSAGGIO ESTERNO CON PERNO REGOLABILE	ALLUMINIO	PEZZI 20
	30B114	GREZZO	KIT FISSAGGIO CARDINI	ALLUMINIO	KIT 20
	30B116	GREZZO	TAPPO DI SICUREZZA PER Cod. 30 B 110 Cod. 30 B 111 - 30 B 112 - 30 B 115	OTTONE- ACC.INOX	PEZZI 20
	30B120D 30B120S	GREZZO RAL9005 RAL8017 RAL6005	CARDINI DX-SX PER TERZA ANTA STORICA FISSAGGIO INTERNO	ALLUMINIO	PEZZI 20Dx PEZZI 20Sx
	30B121	GREZZO RAL9005 RAL8017 RAL6005	CARDINI DX-SX A SQUADRO PER ANTA STORICA FISSAGGIO INTERNO CON PERNO REGOLABILE	ALLUMINIO	COPIA 10

ACCESSORI	CODICE	COLORE	DESCRIZIONE	MATER.	CONFEZ.
	30 C 111	NERO	FERMO A MARMO	ZINCATO	PEZZI 200
	30 C 112	NERO	FERMO A VITE	ZINCATO	PEZZI 200

ACCESSORI	CODICE	COLORE	DESCRIZIONE	MATER.	CONFEZ.
	33B087	RAL9005	CARDINE REGOLABILE CON MENSOLA STRETTA SPALLA 62-70mm	ACCIAIO	PEZZI 20
	33B088	RAL9005	CARDINE REGOLABILE CON MENSOLA STRETTA SPALLA 67-125mm	ACCIAIO	PEZZI 20
	33B089	RAL9005	CARDINE REGOLABILE CON MENSOLA STRETTA SPALLA 97-190mm	ACCIAIO	PEZZI 20
	33B090	RAL9005	CARDINE REGOLABILE CON MENSOLA STRETTA SPALLA 145-225mm	ACCIAIO	PEZZI 20
	33B091	RAL9005	SUPPORTO CERNIERA PER Cod. 33B092	ZAMA	PEZZI 20
	33B092	RAL9005	CERNIERA REGOLABILE COLLO ALTO	ZAMA	PEZZI 20
	33B095	RAL9005	CARDINE 85mm REGOLABILE FISSAGGIO A TASSELLO	ACCIAIO	PEZZI 20
	33B096	RAL9005	CARDINE 125mm REGOLABILE FISSAGGIO A TASSELLO	ACCIAIO	PEZZI 20

ACCESSORI	CODICE	COLORE	DESCRIZIONE	MATER.	CONFEZ.
	33B097	RAL9005	CARDINE 145mm REGOLABILE FISSAGGIO A TASSELLO	ACCIAIO	PEZZI 20
	33B098	RAL9005	CARDINE 175mm REGOLABILE FISSAGGIO A TASSELLO	ACCIAIO	PEZZI 20
	33B099 D	RAL9005	CERNIERA REGOLABILE 45x8 DX COLLO 45x26mm	ZAMA	PEZZI 20
	33B099 S	RAL9005	CERNIERA REGOLABILE 45x8 SX COLLO 45x26	ZAMA	PEZZI 20
	33B100 D	RAL9005	CERNIERA REGOLABILE 19x8 DX COLLO 19x26mm	ZAMA	PEZZI 20
	33B100 S	RAL9005	CERNIERA REGOLABILE 19x8 SX COLLO 19x26mm	ZAMA	PEZZI 20
	33B101	RAL9005	BANDELLA VERTICALE PER CERNIERA	ACCIAIO	PEZZI 20
	33B102	RAL9005	SQUADRO PER CERNIERA SUPERIORE SX. - INFERIORE DX.	ACCIAIO	PEZZI 20

ACCESSORI	CODICE	COLORE	DESCRIZIONE	MATER.	CONFEZ.
	33B103	RAL9005	SQUADRO PER CERNIERA SUPERIORE DX. - INFERIORE SX.	ACCIAIO	PEZZI 20
	33B104	RAL9005	CERNIERA REGOLABILE COLLO 40mm	ZAMA	PEZZI 20
 <small>Barbata minima 15.0x11</small>	33B105	RAL9005	SUPPORTO CERNIERA PER Cod. 33B104 PER SQUADRI E BANDELLE	ZAMA	PEZZI 20
 <small>Barbata minima 15.0x11</small>	33B106	RAL9005	SUPPORTO A FILO PER Cod. 33B104 PER SQUADRI E BANDELLE	ZAMA	PEZZI 20
	33B107	RAL9005	CERNIERA REGOLABILE COLLO 25mm	ZAMA	PEZZI 20
	33B108	RAL9005	CARDINE 85mm FISSAGGIO A TASSELLO	ACCIAIO	PEZZI 20
	33B109	RAL9005	CARDINE 125mm FISSAGGIO A TASSELLO	ACCIAIO	PEZZI 20
	33B110	RAL9005	CARDINE 145mm FISSAGGIO A TASSELLO	ACCIAIO	PEZZI 20

ACCESSORI	CODICE	COLORE	DESCRIZIONE	MATER.	CONFEZ.
	33B111	RAL9005	CARDINE 175mm FISSAGGIO A TASSELLO	ACCIAIO	PEZZI 20
	33B112	RAL9005	CARDINE A MURARE	ACCIAIO	PEZZI 6
	33B113	RAL9005	CERNIERA COMPLANARE DISASSATA PER SQUADRI /BANELLE	ZAMA	PEZZI 20
	33B114	RAL9005	CERNIERA COMPLANARE SIMMETRICA PER SQUADRI/BANELLE	ZAMA	PEZZI 20
	33B115	RAL9005	SPESSORE PER CERNIERE Cod. 33B105 - 33B106	ALLUMINIO	PEZZI 20
	33B119	RAL9005	CARDINE FISSO CON PIASTRINA DA 24mm PER Cod. 33B116	ALLUMINIO	PEZZI 20
	33C099	RAL9005	CONFEZIONE BASE SPAGNOLETTA GRANDE 2 ANTE	ZAMA	PEZZI 20
	33C100	RAL9005	CONFEZIONE BASE SPAGNOLETTA PICCOLA 2 ANTE (CONSIGLIATA NELLA PERSIANA CON LAMELLE ORIENTABILI)	ZAMA	PEZZI 20

ACCESSORI	CODICE	COLORE	DESCRIZIONE	MATER.	CONFEZ.
 <p>Parte con finitura con verniciatura piccola e robusta il ferro mangia il calcio cod. 900001 00.02</p>	33C101	RAL9005	CONFEZIONE BASE SPAGNOLETTA PICCOLA 1 ANTA	ZAMA	PEZZI 20
	33C102	RAL9005	CONFEZIONE BASE SPAGNOLETTA A SCATTO	ZAMA	PEZZI 20
	33C103	RAL9005	PERNO DI CHIUSURA DIRITTO	ACCIAIO	PEZZI 50
	33C104	RAL9005	PIASTRA DI CHIUSURA AD ANGOLO	ACCIAIO	PEZZI 20
	33C105	RAL9005	GUIDA ASTE	ZAMA	PEZZI 50
	33C106	RAL9005	CHIUSURA VERTICALE AD ESPANSIONE DX. CONFEZIONE BASE	ZAMA/ACC.	PEZZI 20
	33C107	RAL9005	CHIUSURA VERTICALE AD ESPANSIONE SX. CONFEZIONE BASE	ZAMA/ACC.	PEZZI 20
	33C108	RAL9005	COMPENSATORE DI ROTAZIONE 180° DX. PER Cod. 33C106	ZAMA	PEZZI 50

ACCESSORI	CODICE	COLORE	DESCRIZIONE	MATER.	CONFEZ.
	33C109	RAL9005	COMPENSATORE DI ROTAZIONE 180° SX. PER Cod. 33C107	ZAMA	PEZZI 50
	33C110	RAL9005	POZZETTO PER SOGLIA	ZAMA	PEZZI 50
	33C111	RAL9005	LAMA DI AGGANCIAMENTO PER IMPOSTA	ACCIAIO	PEZZI 20
	33C112	RAL9005	FERMOIMPOSTA AUTOMATICO A MURO	ZAMA	PEZZI 20
	33C114	RAL9005	BUSSOLE FILETTATE PER Cod. 33C115	ZAMA	PEZZI 100
	33C115	GREZZO	VITE 50mm PER Cod. 33C114	INOX	PEZZI 100
	33C116	RAL9005	ASTA DI CHISURA 1800mm	ACCIAIO	PEZZI 10
	33C117	RAL9005	ASTA DI CHISURA 2400mm	ACCIAIO	PEZZI 10

ACCESSORI	CODICE	COLORE	DESCRIZIONE	MATER.	CONFEZ.
	33C118	RAL9005	ASTA DI CHIUSURA 3200mm	ACCIAIO	PEZZI 10
	33C130	RAL9005	PERNO DI CHIUSURA M8	ACCIAIO	PEZZI 50
	33C131	RAL9005	PERNO DI CHIUSURA Ø10 DA INCOLLARE	ACCIAIO	PEZZI 50
	33C132	RAL9005	PERNO DI CHIUSURA ECCENTRICO	ACC.-ABS	PEZZI 10
	33D100	RAL9005	ROSETTA COPRIFORO CARDINE	ABS	PEZZI 100
	33D101	GREZZO	TASSELLO 100mm	ABS	PEZZI 50
	33D102	GREZZO	TASSELLO 135mm	ABS	PEZZI 50
	33W100		KIT DIME PER IMPOSTE A MURERE	ACCIAIO	PEZZI 1

ACCESSORI	CODICE	COLORE	DESCRIZIONE	MATER.	CONFEZ.
	40 B 23	GREZZO OX.NAT. OX.BRZ. ELETTR. RAL1013 RAL6005 RAL8017 RAL9005 RAL9010	CERNIERA REVERSIBILE CON PIASTRINA DI AGGANCIO	ALLUMINIO	PEZZI 50
	40 C 02	GREZZO	KIT DI COLLEGAMENTO E FISSAGGIO CREMONESE APERTURE ESTERNE	NYLON ALLUMINIO	PEZZI 20
	40 C 03	GREZZO	PERNO DI COLLEGAMENTO CREMONESE APERTURE ESTERNE	ACCIAIO	PEZZI 200
	64 B 10	GREZZO OX.NAT. OX.BRZ. ELETT. RAL1013 RAL6005 RAL8017 RAL9005 RAL9010	CERNIERA REVERSIBILE CON PIASTRINA DI AGGANCIO	ALLUMINIO	PEZZI 50
	64 B 70	GREZZO OX.NAT. OX.BRZ. ELETT. RAL1013 RAL6005 RAL8017 RAL9005 RAL9010	CERNIERA PER TERZA ANTA CON COLLO LUNGO 19 mm	ALLUMINIO	PEZZI 50

ACCESSORI	CODICE	COLORE	DESCRIZIONE	MATER.	CONFEZ.
	64 D 2L	NERO	TERMINALE PER ASTE ESTERNE	NYLON	COPPIA 50
	64 D 3L	NERO	INCONTRO DOPPIO DI CHIUSURA	ZAMA	PEZZI 50
	64 D 4L	NERO	INCONTRO TERZA CHIUSURA	ZAMA	PEZZI 50
	64 D 6L	NERO	PALETTO PER SECONDA ANTA	NYLON	PEZZI 50
	71 C 73	VER.NAT. RAL1013 RAL6005 RAL8017 RAL9005 RAL9010	CREMONESE IN ALLUMINIO "MAXIMA" PER APERTURE ESTERNE	ZAMA	PEZZI 10
	80 D 17	GREZZO	BUSSOLA A PAVIMENTO PER RISCONTRO TERMINALE ASTE DI CHIUSURA	OTTONE	PEZZI 30
	80 D 35	NERO	TAPPO CHIUDIFORO DIAMETRO 11,5mm	PVC	PEZZI 1000

"PIANA" Pr. 27366

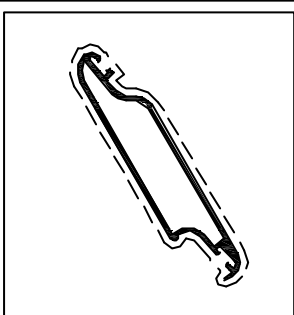

KIT Persiane Orientabili

GARANZIA DI 10 ANNI
per la movimentazione

Richiedi il certificato presso il tuo C.D.

CODICE	DESCRIZIONE	MISURA Kit	LUCE INTERNA ANTA	
			LUCE minima	LUCE massima
SP K 06	Meccanismo di movimentazione 6 lamelle	349	411	470
SP K 07	Meccanismo di movimentazione 7 lamelle	409	471	530
SP K 08	Meccanismo di movimentazione 8 lamelle	469	531	590
SP K 09	Meccanismo di movimentazione 9 lamelle	529	591	650
SP K 10	Meccanismo di movimentazione 10 lamelle	589	651	710
SP K 11	Meccanismo di movimentazione 11 lamelle	649	711	770
SP K 12	Meccanismo di movimentazione 12 lamelle	709	771	830
SP K 13	Meccanismo di movimentazione 13 lamelle	769	831	890
SP K 14	Meccanismo di movimentazione 14 lamelle	829	891	950
SP K 15	Meccanismo di movimentazione 15 lamelle	889	951	1010
SP K 16	Meccanismo di movimentazione 16 lamelle	949	1011	1070
SP K 17	Meccanismo di movimentazione 17 lamelle	1009	1071	1130
SP K 18	Meccanismo di movimentazione 18 lamelle	1069	1131	1190
SP K 19	Meccanismo di movimentazione 19 lamelle	1129	1191	1250
SP K 20	Meccanismo di movimentazione 20 lamelle	1189	1251	1310
SP K 21	Meccanismo di movimentazione 21 lamelle	1249	1311	1370
SP K 22	Meccanismo di movimentazione 22 lamelle	1309	1371	1430
SP K 23	Meccanismo di movimentazione 23 lamelle	1369	1431	1490
SP K 24	Meccanismo di movimentazione 24 lamelle	1429	1491	1550
SP K 25	Meccanismo di movimentazione 25 lamelle	1489	1551	1610
SP K 26	Meccanismo di movimentazione 26 lamelle	1549	1611	1670
SP K 27	Meccanismo di movimentazione 27 lamelle	1609	1671	1730
SP K 28	Meccanismo di movimentazione 28 lamelle	1669	1731	1790
SP K 29	Meccanismo di movimentazione 29 lamelle	1729	1791	1850
SP K 30	Meccanismo di movimentazione 30 lamelle	1789	1851	1910
SP K 54	Meccanismo di movimentazione 54 lamelle (da tagliare)			3350

"GOCCIA" Pr.27367

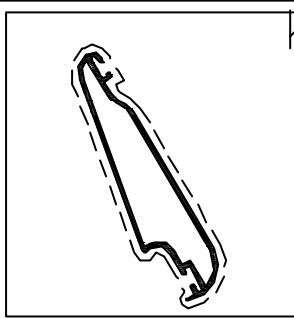

KIT Persiane Orientabili

GARANZIA DI 10 ANNI
per la movimentazione

Richiedi il certificato presso il tuo

"RUSTICA" Pr.27368

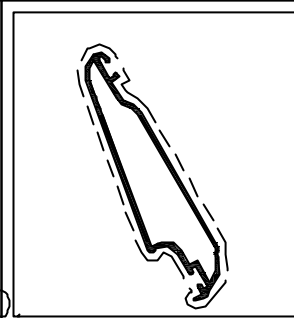

CODICE	DESCRIZIONE	MISURA Kit	LUCE INTERNA ANTA	
			LUCE minima	LUCE massima
SG K 06	Meccanismo di movimentazione 6 lamelle	349	411	470
SG K 07	Meccanismo di movimentazione 7 lamelle	409	471	530
SG K 08	Meccanismo di movimentazione 8 lamelle	469	531	590
SG K 09	Meccanismo di movimentazione 9 lamelle	529	591	650
SG K 10	Meccanismo di movimentazione 10 lamelle	589	651	710
SG K 11	Meccanismo di movimentazione 11 lamelle	649	711	770
SG K 12	Meccanismo di movimentazione 12 lamelle	709	771	830
SG K 13	Meccanismo di movimentazione 13 lamelle	769	831	890
SG K 14	Meccanismo di movimentazione 14 lamelle	829	891	950
SG K 15	Meccanismo di movimentazione 15 lamelle	889	951	1010
SG K 16	Meccanismo di movimentazione 16 lamelle	949	1011	1070
SG K 17	Meccanismo di movimentazione 17 lamelle	1009	1071	1130
SG K 18	Meccanismo di movimentazione 18 lamelle	1069	1131	1190
SG K 19	Meccanismo di movimentazione 19 lamelle	1129	1191	1250
SG K 20	Meccanismo di movimentazione 20 lamelle	1189	1251	1310
SG K 21	Meccanismo di movimentazione 21 lamelle	1249	1311	1370
SG K 22	Meccanismo di movimentazione 22 lamelle	1309	1371	1430
SG K 23	Meccanismo di movimentazione 23 lamelle	1369	1431	1490
SG K 24	Meccanismo di movimentazione 24 lamelle	1429	1491	1550
SG K 25	Meccanismo di movimentazione 25 lamelle	1489	1551	1610
SG K 26	Meccanismo di movimentazione 26 lamelle	1549	1611	1670
SG K 27	Meccanismo di movimentazione 27 lamelle	1609	1671	1730
SG K 28	Meccanismo di movimentazione 28 lamelle	1669	1731	1790
SG K 29	Meccanismo di movimentazione 29 lamelle	1729	1791	1850
SG K 30	Meccanismo di movimentazione 30 lamelle	1789	1851	1910
SG K 54	Meccanismo di movimentazione 54 lamelle (da tagliare)			3350

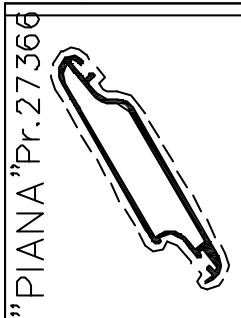

KIT Persiane Orientabili

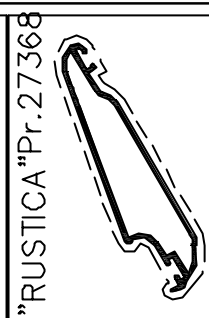
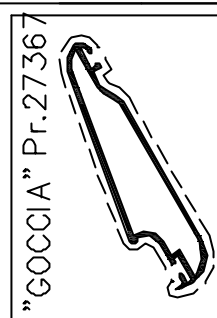

CODICE
SP K 06
SP K 07
SP K 08
SP K 09
SP K 10
SP K 11
SP K 12
SP K 13
SP K 14
SP K 15
SP K 16
SP K 17
SP K 18
SP K 19
SP K 20
SP K 21
SP K 22
SP K 23
SP K 24
SP K 25
SP K 26
SP K 27
SP K 28
SP K 29
SP K 30
SP K 54

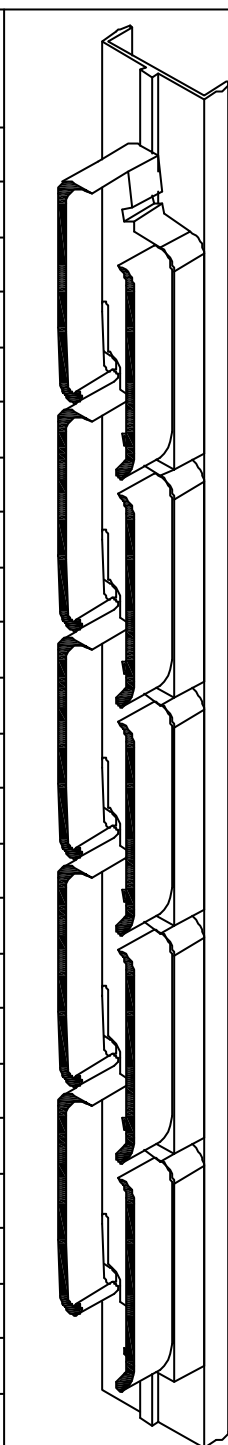





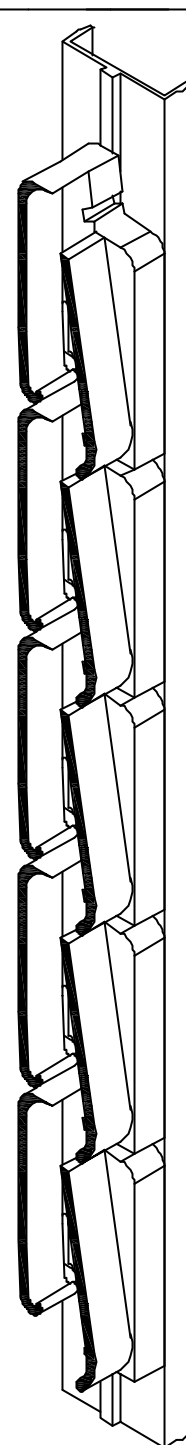



COLORE
NERO
RAL 1013
RAL 6005
RAL 7100
RAL 7200
*RAL 7300
RAL 8001P
RAL 8017
RAL 9010



*Non disponibile a stock.
Solo su ordinazione.





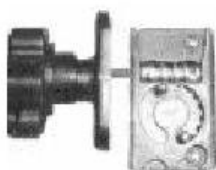

CODICE
SG K 06
SG K 07
SG K 08
SG K 09
SG K 10
SG K 11
SG K 12
SG K 13
SG K 14
SG K 15
SG K 16
SG K 17
SG K 18
SG K 19
SG K 20
SG K 21
SG K 22
SG K 23
SG K 24
SG K 25
SG K 26
SG K 27
SG K 28
SG K 29
SG K 30
SG K 54

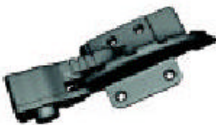





ACCESSORI	CODICE	COLORE	DESCRIZIONE	MATER.	CONFEZ.
	SG D 01	NERO RAL 1013 RAL 6005 RAL 7100 RAL 7200 RAL 7300 RAL 8001P RAL 8017 RAL 9010	COMPENSATORI PER LAMELLE A GOCCIA FISSE APERTE	NYLON	COPPIE 20
	SG D 10	NERO RAL 1013 RAL 6005 RAL 7100 RAL 7200 RAL 7300 RAL 8001P RAL 8017 RAL 9010	SELLE PER LAMELLE A GOCCIA FISSE APERTE	NYLON	PEZZI 100
	SG D 20	NERO RAL 1013 RAL 6005 RAL 7100 RAL 7200 RAL 7300 RAL 8001P RAL 8017 RAL 9010	TAPPI PER LAMELLE A GOCCIA FISSE CIECHE	NYLON	COPPIE 10
	SP D 01	NERO RAL 1013 RAL 6005 RAL 7100 RAL 7200 RAL 7300 RAL 8001P RAL 8017 RAL 9010	COMPENSATORI PER LAMELLE PIANE FISSE APERTE	NYLON	COPPIE 20
	SP D 10	NERO RAL 1013 RAL 6005 RAL 7100 RAL 7200 RAL 7300 RAL 8001P RAL 8017 RAL 9010	SELLE PER LAMELLE PIANE FISSE APERTE	NYLON	PEZZI 100





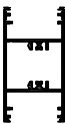

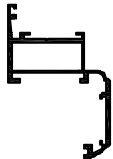

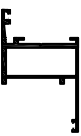
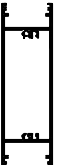
ACCESSORI	CODICE	COLORE	DESCRIZIONE	MATER.	CONFEZ.
	SP D 20	NERO RAL 1013 RAL 6005 RAL 7100 RAL 7200 RAL 7300 RAL 8001P RAL 8017 RAL 9010	TAPPI PER LAMELLE PIANE FISSE CIECHE	NYLON	COPPIE 10
	SU D 90	NERO RAL 1013 RAL 6005 RAL 7100 RAL 7200 RAL 7300 RAL 8001P RAL 8017 RAL 9010	COMPENSATORI PER LAMELLE FISSE CIECHE	NYLON	COPPIE 20
	SU G 01	NERO	GUARNIZIONE DI BATTUTA PER LAMELLE	EPDM	Mt. 500

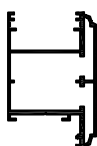



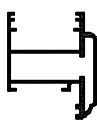

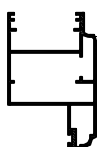

ACCESSORI	CODICE	COLORE	DESCRIZIONE	MATER.	CONFEZ.
	SU K 95	NERO RAL 1013 RAL 6005 RAL 7100 RAL 7200 RAL 7300 RAL 8001P RAL 8017 RAL 9010	MANIGLIA A ROTAZIONE AMBIDESTRA "MARGHERITA" CON POMELLO ESTRAIBILE * COMPRESI COMPENSATORI	ZAMA/OTT NYLON CARIC.F.V.	PEZZI 1
	SU K 96	NERO RAL 1013 RAL 6005 RAL 7100 RAL 7200 RAL 7300 RAL 8001P RAL 8017 RAL 9010	MANIGLIA A ROTAZIONE AMBIDESTRA "MARGHERITA" * COMPRESI COMPENSATORI	ZAMA/OTT NYLON CARIC.F.V.	PEZZI 1
	SU K 97	NERO RAL 1013 RAL 6005 RAL 7100 RAL 7200 RAL 7300 RAL 8001P RAL 8017 RAL 9010	MANIGLIA A ROTAZIONE AMBIDESTRA "GIRASOLE" CON TESTA RIBASSATA ESTRAIBILE (CONSIGLIATA PER PERSIANA ORIENTABILE SU DOMAL GARDEN) * COMPRESI COMPENSATORI	ZAMA/OTT NYLON CARIC.F.V.	PEZZI 1
	SU K 98	NERO RAL 1013 RAL 6005 RAL 7100 RAL 7200 RAL 7300 RAL 8001P RAL 8017 RAL 9010	MANIGLIA A LEVA "GRIP" CON BLOCCO DX NUMERO MAX LAMELLE MOVIMENTABILI = 20 * COMPRESI COMPENSATORI	NYLON CARIC.F.V.	PEZZI 1
	SU K 99	NERO RAL 1013 RAL 6005 RAL 7100 RAL 7200 RAL 7300 RAL 8001P RAL 8017 RAL 9010	MANIGLIA A LEVA "GRIP" CON BLOCCO SX NUMERO MAX LAMELLE MOVIMENTABILI = 20 * COMPRESI COMPENSATORI	NYLON CARIC.F.V.	PEZZI 1

SEZIONE	CODICE	DESCRIZIONE	BOBINE m	SCATOLA m
	90 G 31	GUARNIZIONE DI BATTUTA MATERIALE: EPDM COLORE: NERO	DOPPIA 400	DOPPIA 400
	90 G 91	GUARNIZIONE DI BATTUTA A BASE RIGIDA MATERIALE: EPDM-PVC COLORE: NERO	300	600
	90 G 97	GUARNIZIONE DI BATTUTA MATERIALE: EPDM COLORE: NERO	250	250

ATTREZZATURE	CODICE	DESCRIZIONE	CONFEZ.
	40 W 45	PUNZONATRICE PER SQUADRETTA 15 A 46	PEZZI 1

SEZIONE	CODICE	PESO Kg/m.	SUP. IN VISTA mm.	PAGINA	DESCRIZIONE
	Pr 10763	0,347	111	B 04	PROFILATO OVALINA mm. 50
	Pr 13199	0,448	141	B 04	PROFILATO OVALINA mm. 65
	Pr 16012	1,509	221	B 03	PROFILATO FASCIA mm. 100
	Pr 16013	1,207	165	B 03	PROFILATO ZOCCOLO mm. 75
	Pr 19730	0,165	23	B 02	PROFILATO ASTA DI CHIUSURA
	Pr 21688	0,662	74	B 02	PROFILATO BATTUTA DI RIPORTO (o STULP)
	Pr 23328	0,902	138	B 01	PROFILATO TELAIO
	Pr 23339	0,680	71	B 02	PROFILATO BATTUTA DI RIPORTO
	Pr 26200	0,684	96	B 01	PROFILATO TELAIO
	Pr 26210	1,785	272	B 03	PROFILATO FASCIA mm. 130

SEZIONE	CODICE	PESO Kg/m.	SUP. IN VISTA mm.	PAGINA	DESCRIZIONE
	Pr 26230	0,505	160	B 04	PROFILATO LAMELLA FIORENTINA mm. 70
	Pr 26235	1,188	148	B 02	PROFILATO ANTA MAGGIORATA
	Pr 26236	0,994	116	B 02	PROFILATO ANTA
	Pr 26237	0,208	42	B 02	PROFILATO DI FINITURA CHIUDI TUBOLARITA'
	Pr 26238	0,840	161	B 01	PROFILATO SPORTELLO mm. 60 (SOLO PER LAMELLE FISSE)
	Pr 26239	0,726	137	B 01	PROFILATO SPORTELLO mm. 47 (SOLO PER LAMELLE FISSE)
	Pr 26240	0,964	116	B 01	PROFILATO ANTA
	Pr 27357	0,538	45	B 02	PROFILATO DI RIPORTO A SCOMPARSA
	Pr 27359	1,110	210	B 01	PROFILATO ANTA MAGGIORATA
	Pr 27360	0,605	190	B 04	PROFILATO LAMELLA FIORENTINA mm. 80

SEZIONE	CODICE	PESO Kg/m.	SUP. IN VISTA mm.	PAGINA	DESCRIZIONE
	Pr 27361	0,354	45	B 02	PROFILATO PER SELLE
	Pr 27366	0,490	157	B 05	PROFILATO LAMELLA "PIANA" mm. 70
	Pr 27367	0,499	160	B 05	PROFILATO LAMELLA "GOCCIA" mm. 70
	PR 27368	0,494	158	B 05	PROFILATO LAMELLA "RUSTICA" mm. 70
	Pr 27369	0,375	105	B 05	PROFILATO COMPENSATORE
	Pr 27370	0,381	47	B 05	PROFILATO COMPENSATORE
	Pr 27374	1,492	293	B 05	PROFILATO ROMPIRATTA P60
	Pr 27538	0,748	139	B 01	PROFILATO SPORTELLO mm. 47 (ANCHE PER LAMELLE ORIENTABILI)
	Pr 50013	0,240	111	B 04	PROFILATO OVALINA mm. 50 (ALLEGGERITA)

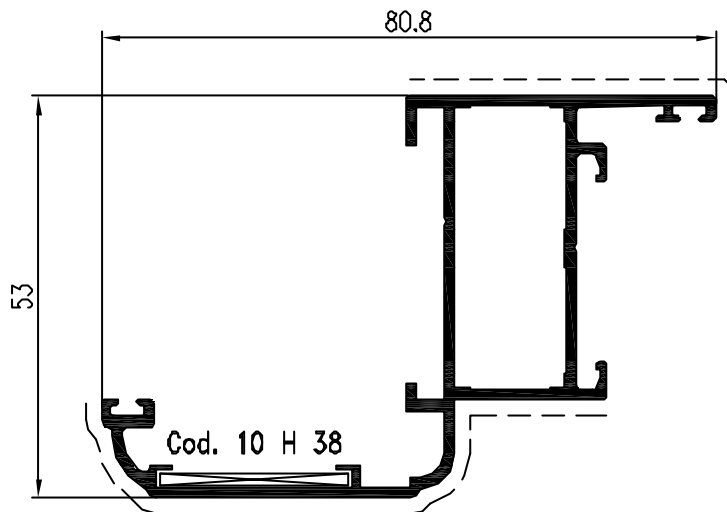

Pr. 23328 kg/m. 0.902
sup. in vista mm. 138

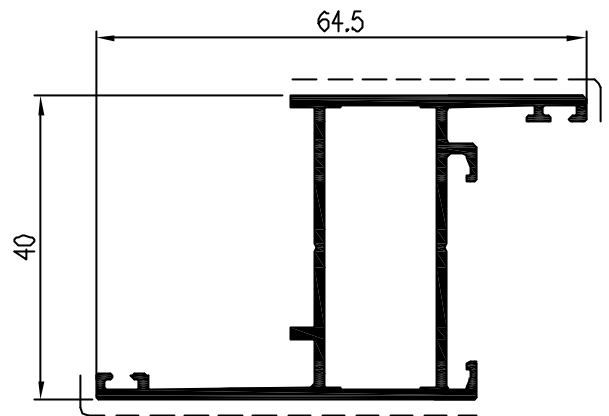

Pr. 26200 kg/m. 0.684
sup. in vista mm. 96

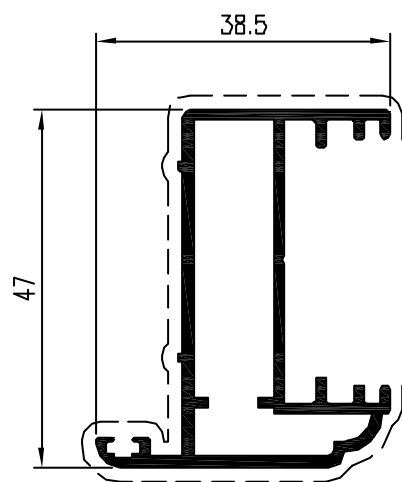

Pr. 26239 kg/m. 0.726
sup. in vista mm. 137

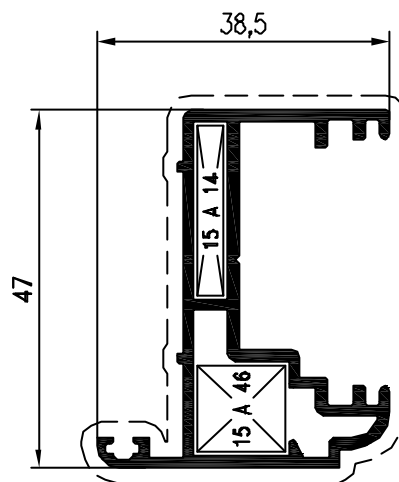

Pr. 27538 kg/m. 0.748
sup. in vista mm. 139

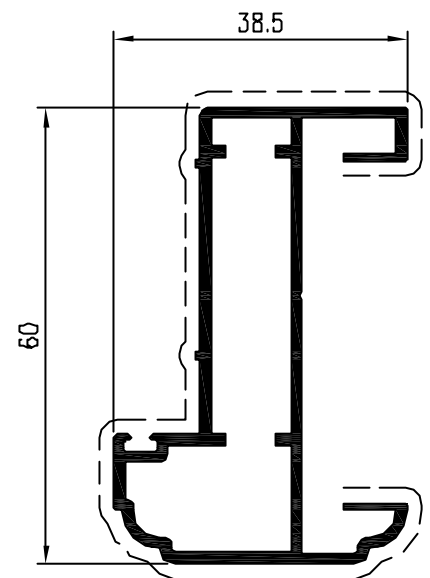

Pr. 26238 kg/m. 0.840
sup. in vista mm. 161

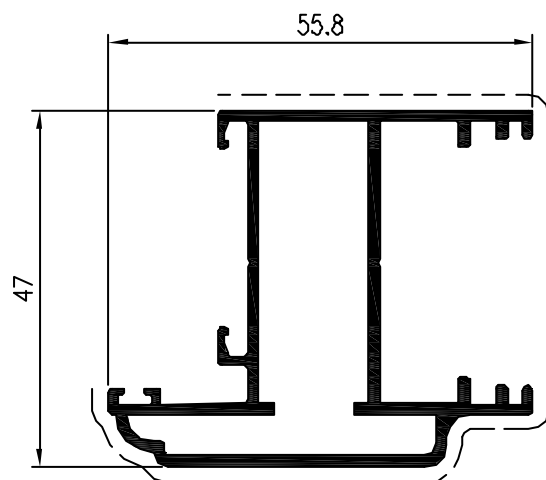

Pr. 26240 kg/m. 0.964
sup. in vista mm. 116

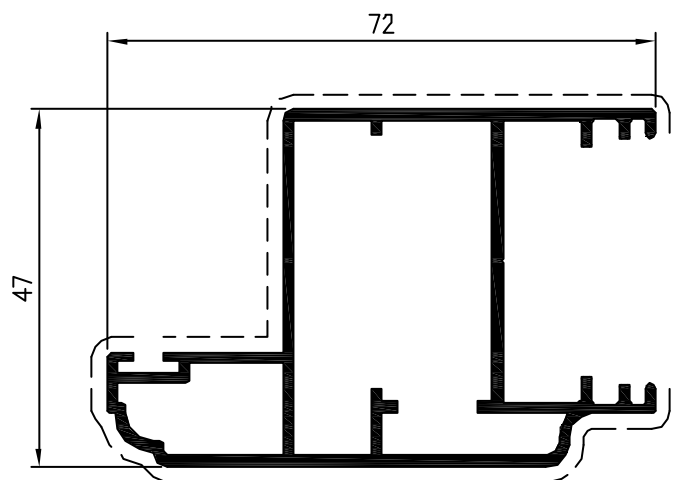

Pr. 27359 kg/m. 1.110
sup. in vista mm. 210

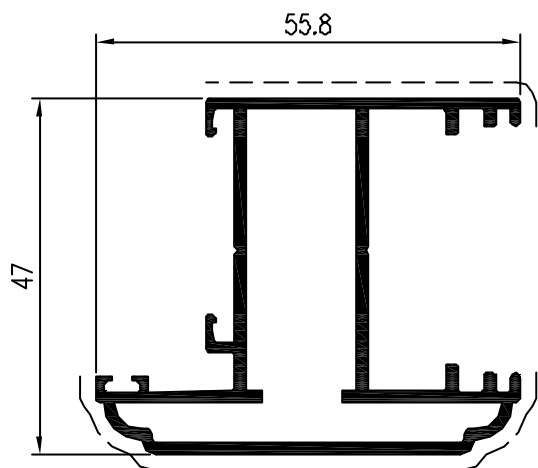

Pr. 26236 kg/m. 0.994
sup. in vista mm. 116

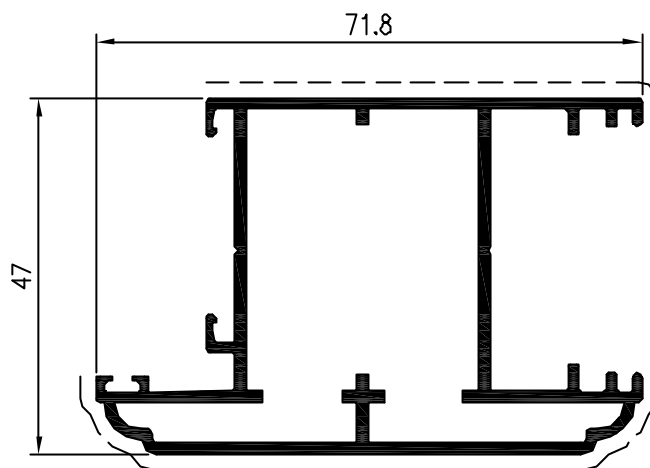

Pr. 26235 kg/m. 1.188
sup. in vista mm. 148

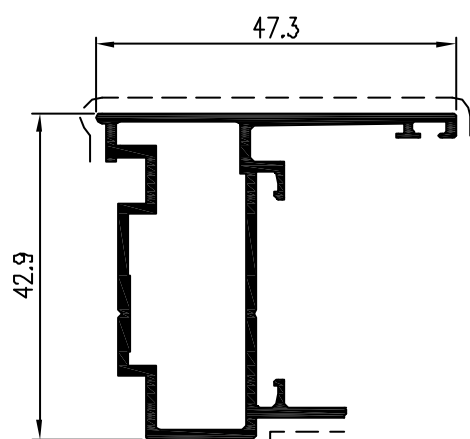

Pr. 21688 kg/m. 0.662
sup. in vista mm. 74

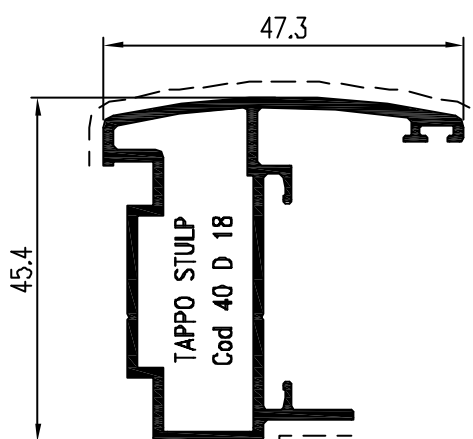

Pr. 23339 kg/m. 0.680
sup. in vista mm. 71

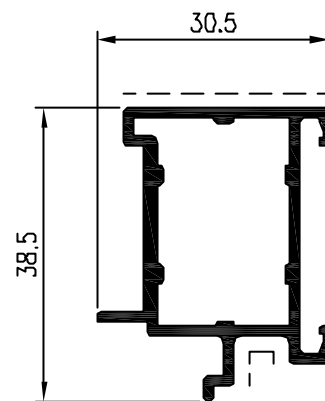

Pr. 27357 kg/mkg/m. 0.538
sup. in vista mm. 45

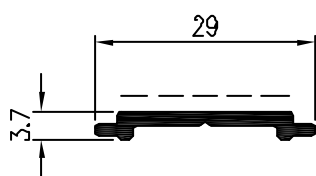

Pr. 19730 kg/m. 0.165
sup. in vista mm. 23

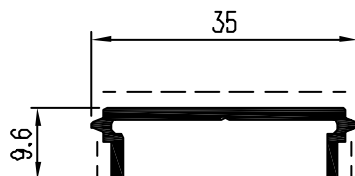

Pr. 26237 kg/m. 0.208
sup. in vista mm. 42

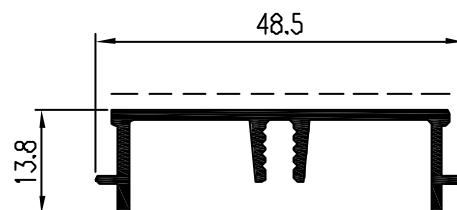

Pr. 27361 kg/m. 0.354
sup. in vista mm. 45

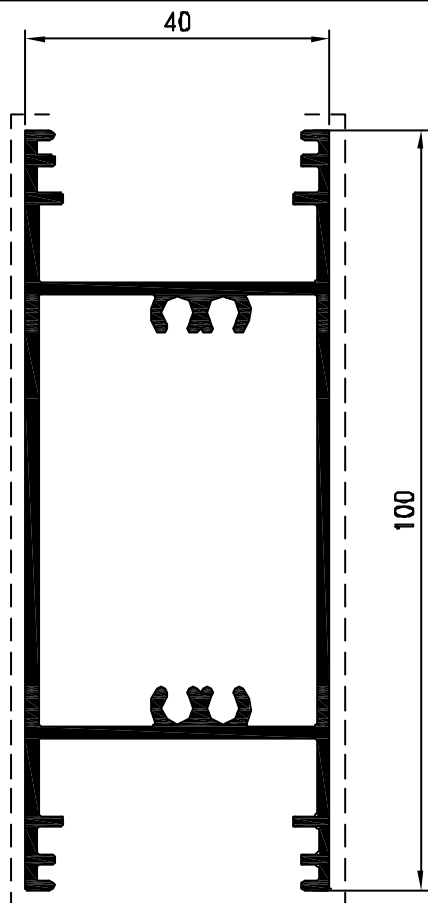

Pr. 16012 kg/m. 1.509
sup. in vista mm. 221

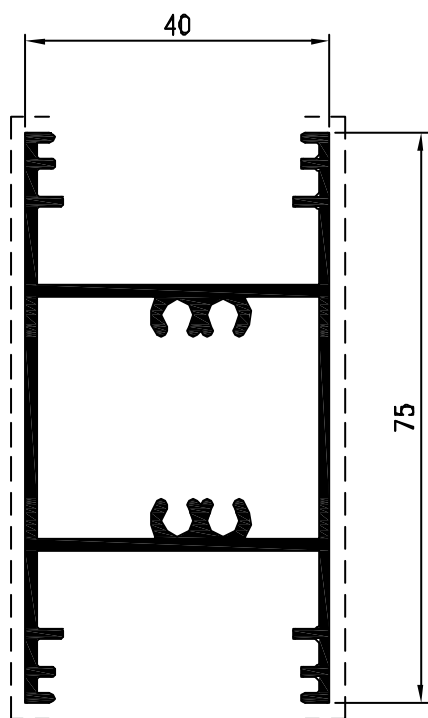

Pr. 16013 kg/m. 1.207
sup. in vista mm. 165

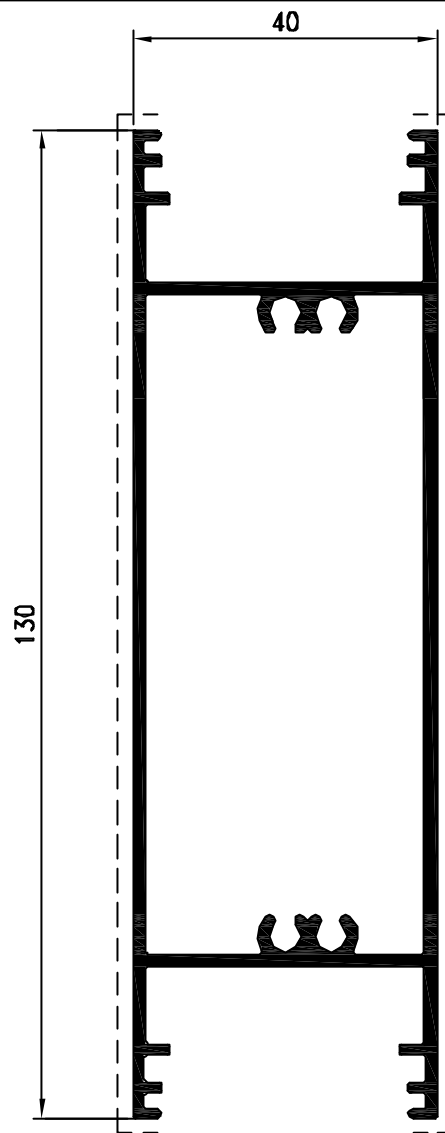

Pr. 26210 kg/m. 1.785
sup. in vista mm. 262

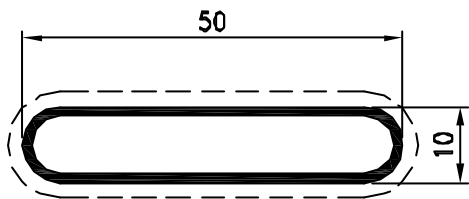

Pr. 10763 kg/m. 0.347
sup. in vista mm. 111

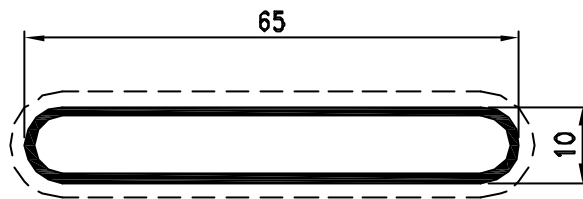

Pr. 13199 kg/m. 0.448
sup. in vista mm. 141

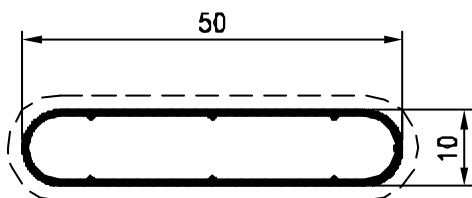

Pr. 50013 kg/m. 0.240
sup. in vista mm. 111

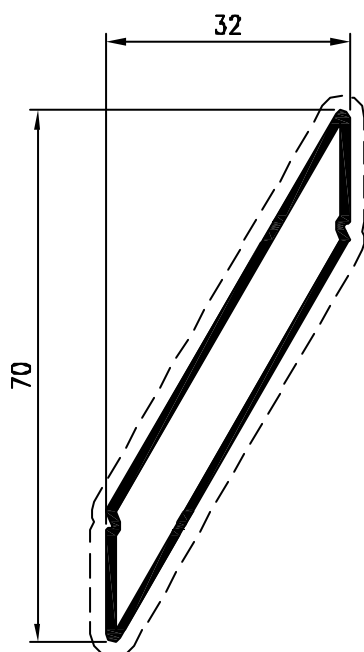

Pr. 26230 kg/m. 0.505
sup. in vista mm. 160

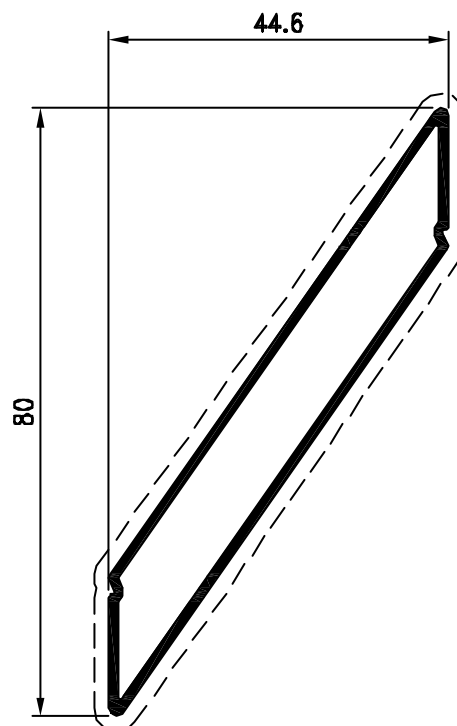

Pr. 27360 kg/m. 0.605
sup. in vista mm. 190

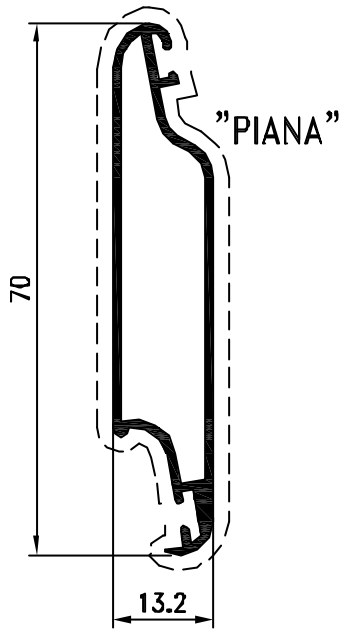

Pr. 27366 kg/m. 0.490
sup. in vista mm. 157

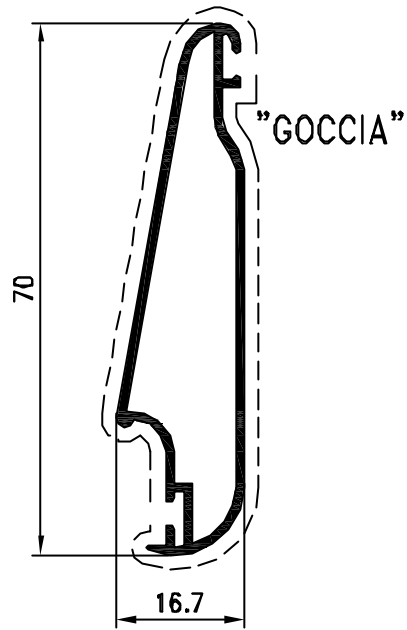

Pr. 27367 kg/m. 0.499
sup. in vista mm. 160

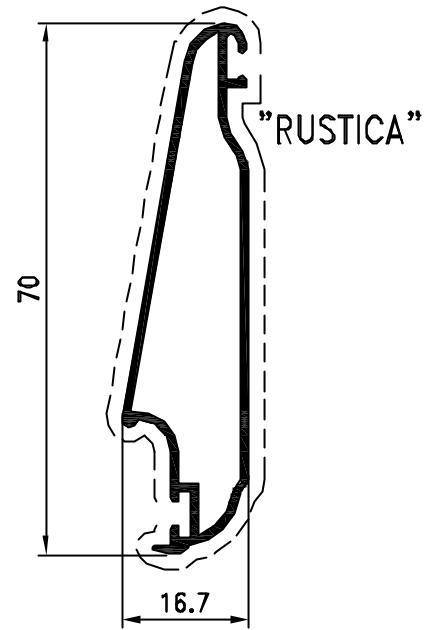

Pr. 27368 kg/m. 0.494
sup. in vista mm. 158

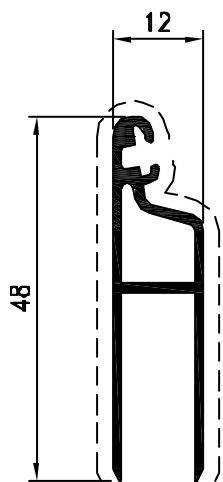

Pr. 27369 kg/m. 0.375
sup. in vista mm. 108

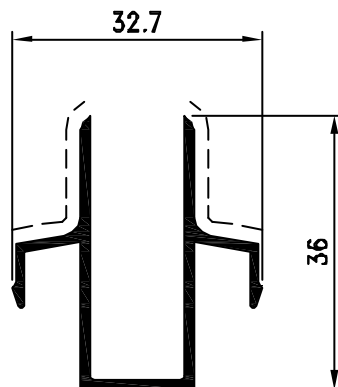

Pr. 27370 kg/m. 0.381
sup. in vista mm. 47

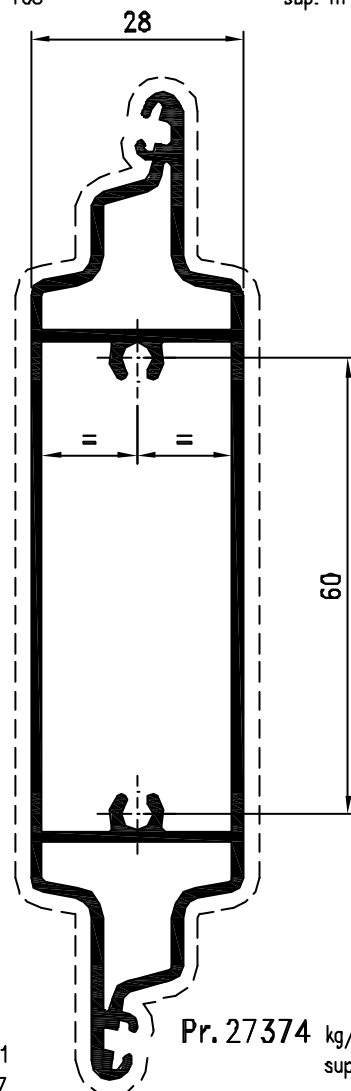

Pr. 27374 kg/m. 1.492
sup. in vista mm. 293

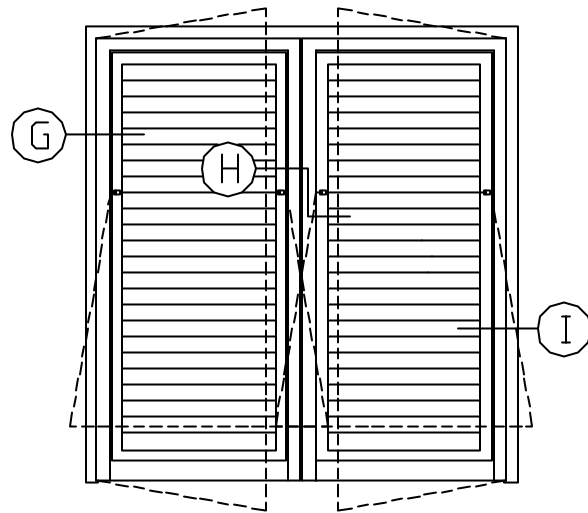

GELOSIA 2 ANTE

LA SEZIONE VERTICALE E' A PAGINA SEGUENTE

PROFILI GELOSIA 2 ANTE

Nr. Pezzi	Pr	Descrizione	Taglio
2	26200	Montante telaio	H+25.5
1	26200	Traverso telaio	L+51
4	26240	Montante anta	H-25
2	26240	Traverso anta	L/2-20.5
1	21688	Stulp	H-51
4	26239	Montante antina	H-143
4	26239	Traverso antina	L/2-119.5
4	26237	Traversi di finitura antine	L/2-196.5
4	26237	Montanti profilato distanziale	H-74.5
6	26237	Traversi sup.-inf. profilato distanziale	L/2-119.5
2	16013	Zoccolo	L/2-132
1	19730	Asta cremonese	

LAMELLE 70mm

$\frac{H-220}{55} \times 2$	26230	Lamella 70mm	L/2-180
-----------------------------	-------	--------------	---------

OVALINE 65mm

$\frac{H-220}{55} \times 2$	13199	Ovalina 65mm	L/2-168.5
-----------------------------	-------	--------------	-----------

OVALINE 50mm

$\frac{H-220}{40} \times 2$	10763	Ovalina 50mm	L/2-168.5
-----------------------------	-------	--------------	-----------

GUARNIZIONI

Codice	Descrizione	Taglio
90 G 31	Guarnizione per battuta	4L+10H

ACCESSORI

Nr. Pezzi	Codice	Descrizione
6	04 A 21	Squadretta in alluminio pressofuso
8	30 A 10	Squadretta in alluminio pressofuso
4	64 B 10	Cerniera ELETTROCOLORE
1	71 C 73	Cremonese ELETTROCOLORE
1	40 C 02	Kit di collegamento cremonese
2	40 C 03	Perni di collegamento asta
4	30 B 90	Cerniere per antine
2 coppie	30 D 91	Tappi taglio antine
4	30 D 04	Tappo traversi
2 coppie	30 D 75	Tappi chiudi tubolarita' inferiore
1	40 D 08	Tappo stulp superiore
1	30 D 17	Tappo stulp inferiore
2	64 D 2L	Terminali per aste esterne
1	64 D 3L	Incontro doppio di chiusura

LAMELLE DA 70mm

$\frac{H-220}{55} \times 2$ coppie	30 D A0	Selle
4 coppie	30 D B0	Compensatori

OVALINE 65mm

$\frac{H-220}{55} \times 4$	30 D 21	Selle reversibili
4 coppie	30 D 41	Mezze selle

OVALINE 50mm

$\frac{H-220}{40} \times 4$	30 D 22	Selle reversibili
4 coppie	30 D 42	Mezze selle

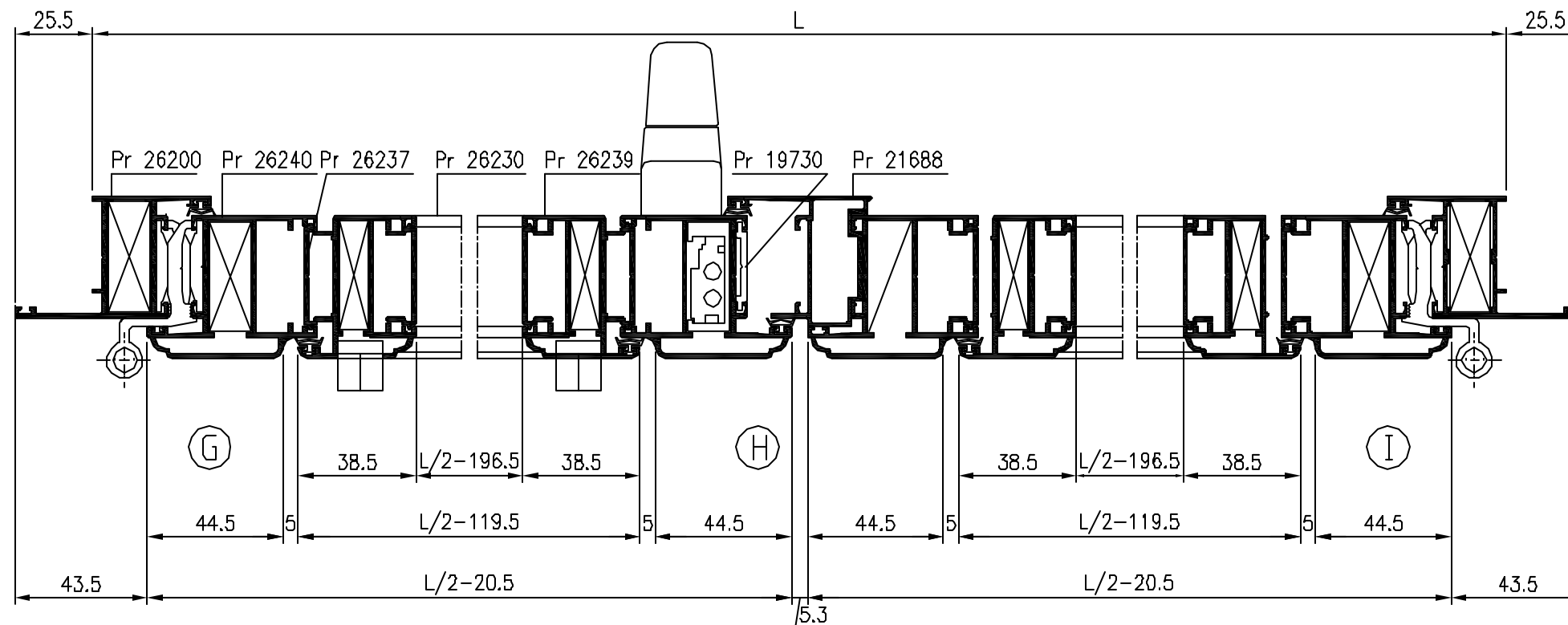

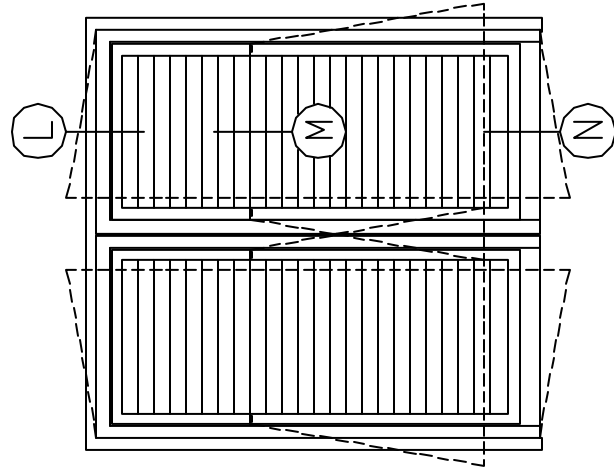

GELOSIA 2 ANTE

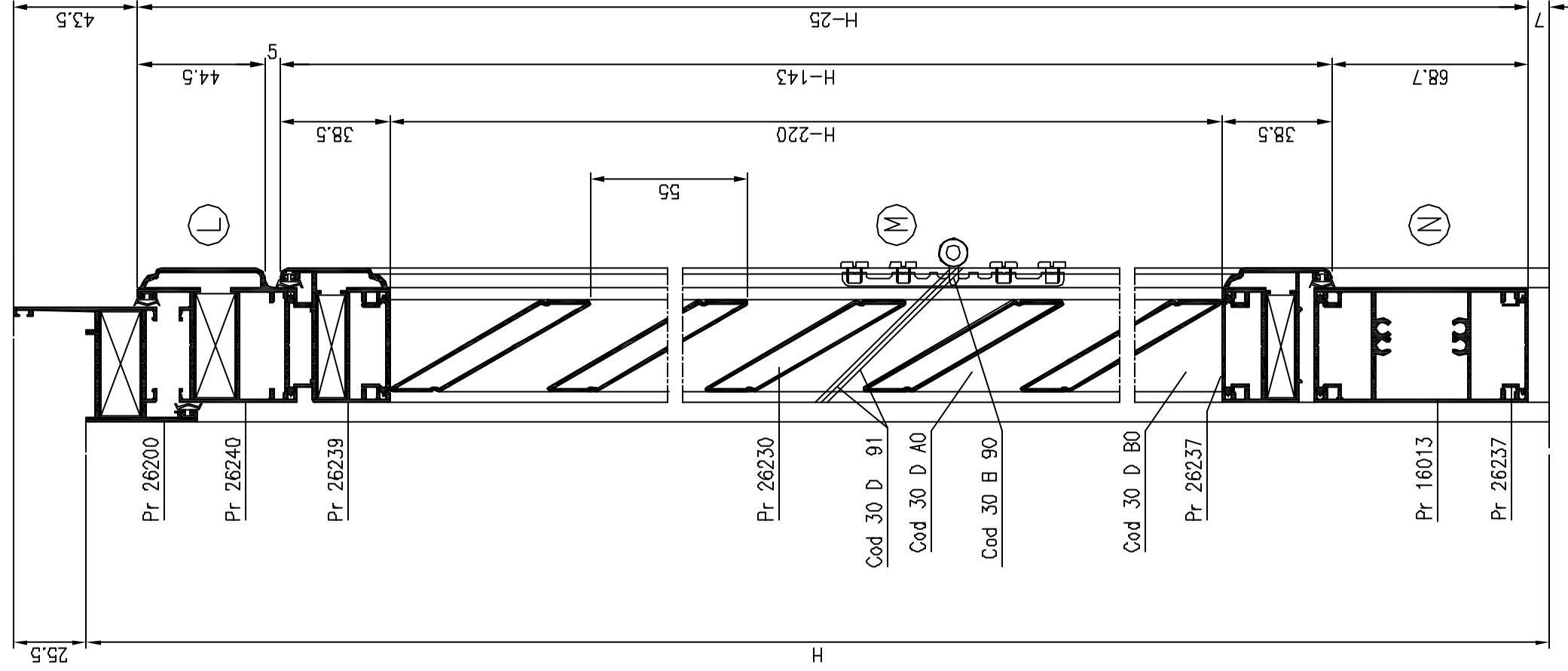

PROFILI GELOSIA 3 ANTE

Nr. Pezzi	Pr	Descrizione	Taglio
2	26200	Montante telaio	H+25.5
1	26200	Traverso telaio	L+51
6	26240	Montante anta	H-25
3	26240	Traverso anta	L/3-15.5
2	21688	Stulp	H-51
6	26239	Montante antina	H-143
6	26239	Traverso antina	L/3-114.5
6	26237	Traversi di finitura antine	L/3-191.5
6	26237	Montanti profilato distanziale	H-74.5
9	26237	Traversi sup.-inf. profilato distanziale	L/3-114.5
3	16013	Zoccolo	L/3-127
1	19730	Asta cremonese	

PROFILI GELOSIA 4 ANTE

Nr. Pezzi	Pr	Descrizione	Taglio
2	26200	Montante telaio	H+25.5
1	26200	Traverso telaio	L+51
8	26240	Montante anta	H-25
4	26240	Traverso anta	L/4-13
3	21688	Stulp	H-51
8	26239	Montante antina	H-143
8	26239	Traverso antina	L/4-112
8	26237	Traversi di finitura antine	L/4-189
8	26237	Montanti profilato distanziale	H-74.5
12	26237	Traversi sup.-inf. profilato distanziale	L/4-112
4	16013	Zoccolo	L/4-124.5
1	19730	Asta cremonese	

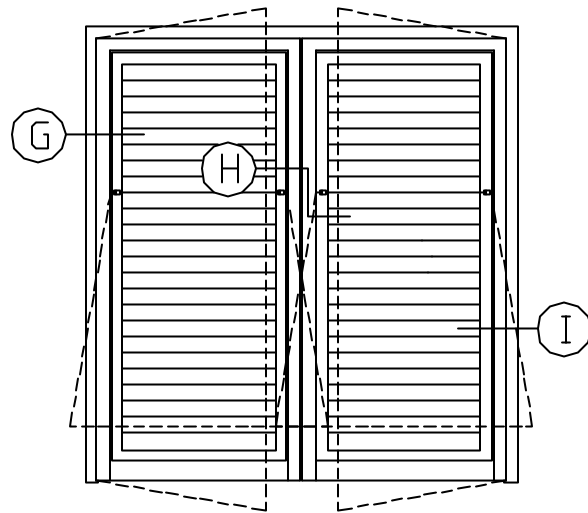

GELOSIA 2 ANTE

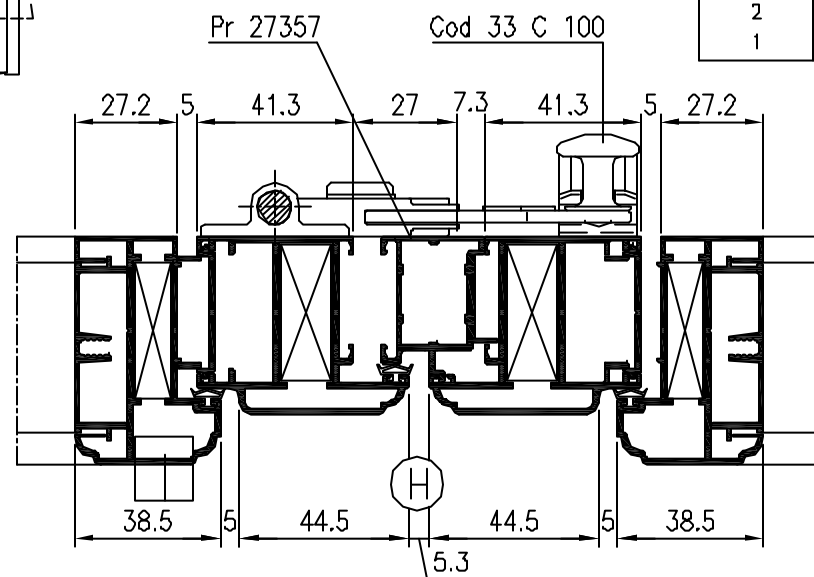

PROFILI GELOSIA 2 ANTE

Nr. Pezzi	Pr	Descrizione	Taglio
2	23328	Montante telaio	H+40
1	23328	Traverso telaio	L+80
4	26240	Montante anta	H-27
2	26240	Traverso anta	L/2-22.5
1	21688	Stulp	H-53
4	26238	Montante antina	H-145
4	26238	Traverso antina	L/2-121.5
4	27361	Traversi di finitura antine	L/2-198.5
4	26237	Montanti profilato distanziale	H-76
3	26237	Traversi sup.-inf. profilato distanziale	L/2-121.5
2	16013	Zoccolo	L/2-134
1	19730	Asta cremanese	

LAMELLE 80mm

H-222 65	x2 coppie	27360	Lamella 80mm	L/2-165.5
-------------	-----------	-------	--------------	-----------

GUARNIZIONI

Codice	Descrizione	Taglio
90 G 31	Guarnizione per battuta	4L+10H

ACCESSORI

Nr. Pezzi	Codice	Descrizione
6	04 A 21	Squadretta in alluminio pressofuso
8	30 A 10	Squadretta in alluminio pressofuso
2	10 H 38	Squadretta in alluminio per Pr 23328
4	40 B 23	Cerniera ELETTROCOLORE
1	71 C 73	Cremanese ELETTROCOLORE
1	40 C 02	Kit di collegamento cremanese
1	40 D 08	Tappi per Pr 21688
2	64 D 2L	Terminali per aste esterne
1	64 D 3L	Incontro doppio di chiusura
2	40 C 03	Perni di collegamento asta
4	30 B 90	Cerniere per antine
2 coppie	30 D 92	Tappi taglio antine
4	30 D 04	Tappo traversi
2 coppie	30 D 75	Tappi chiudi tubolarita' inferiore
1 coppia	30 D 17	Tappi stulp

LAMELLE 80mm

H-222 65	x2 coppie	30 D C0	Selle
4 coppie		30 D D0	Compensatori

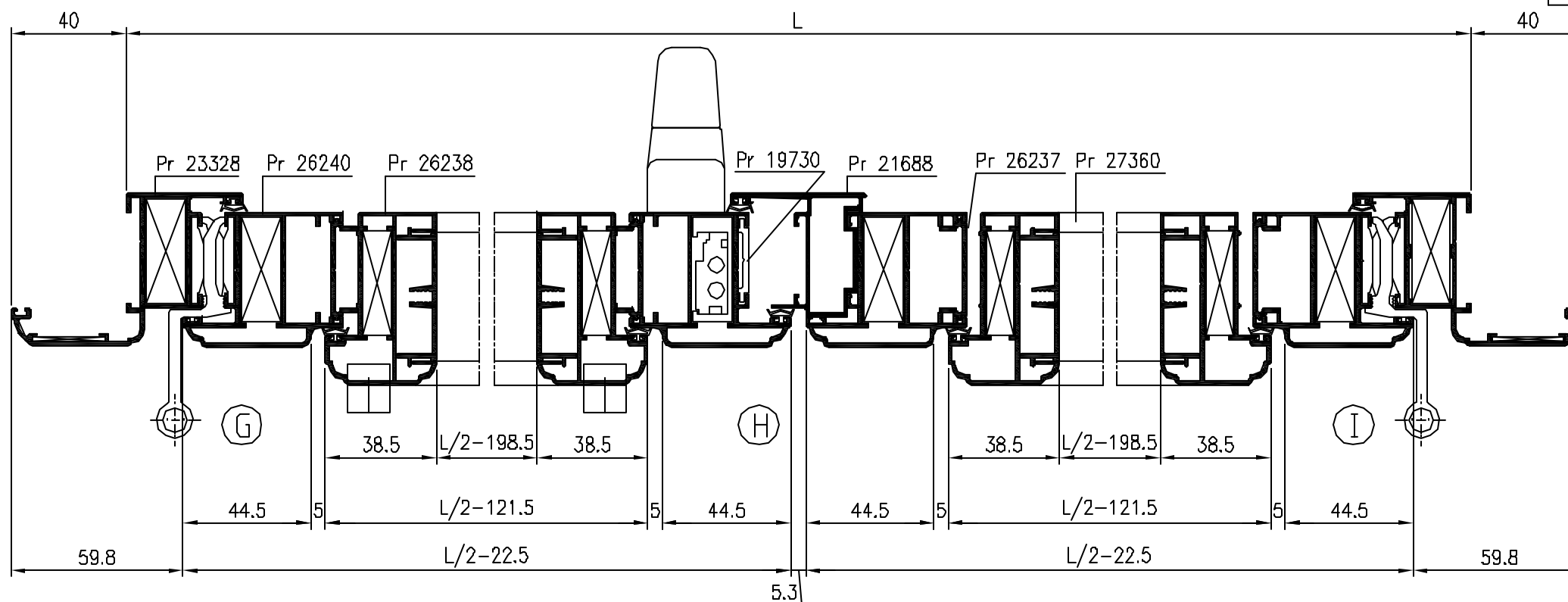

LA SEZIONE VERTICALE E' A PAGINA SEGUENTE

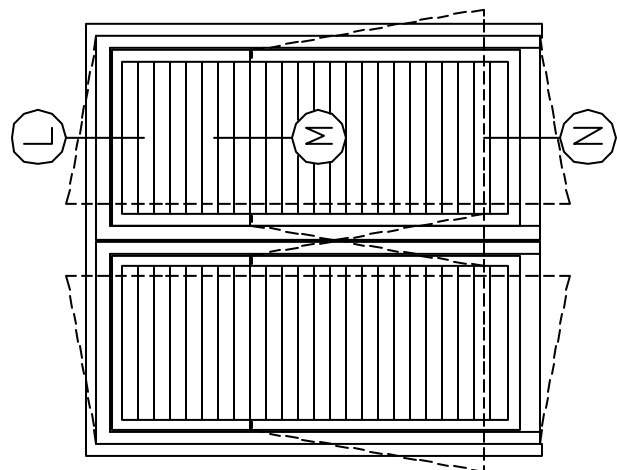
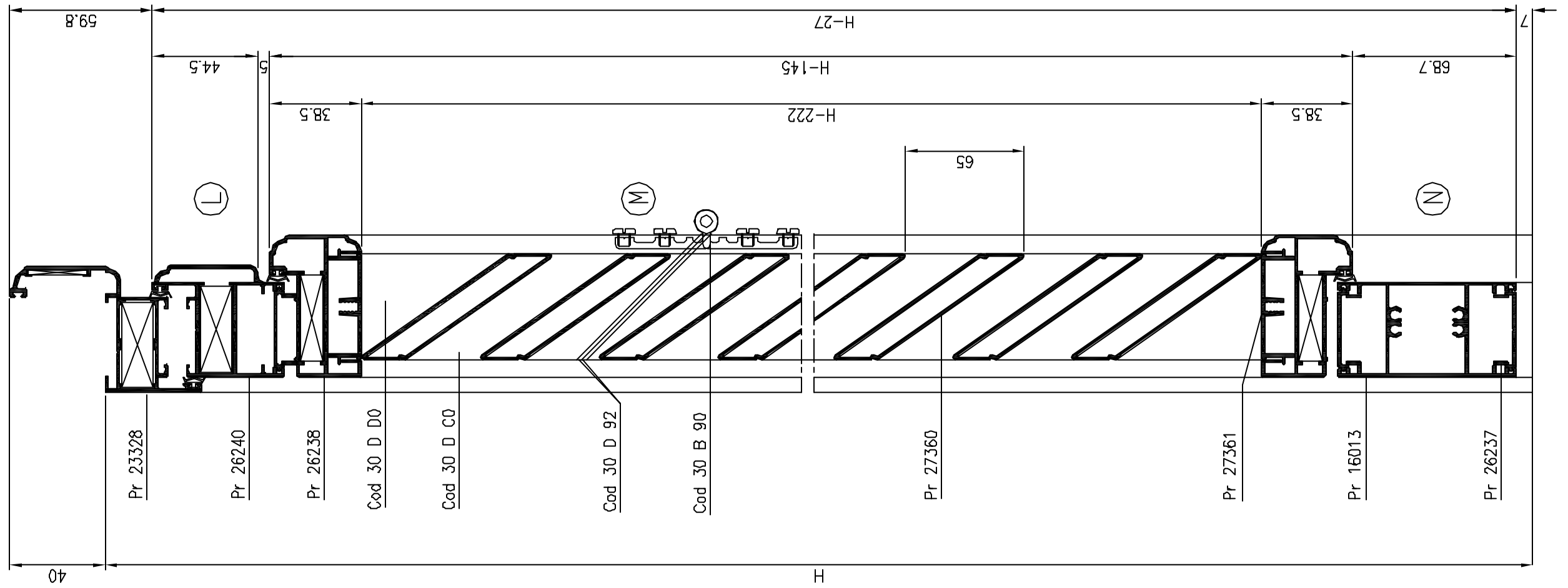

GELOSIA 2 ANTE

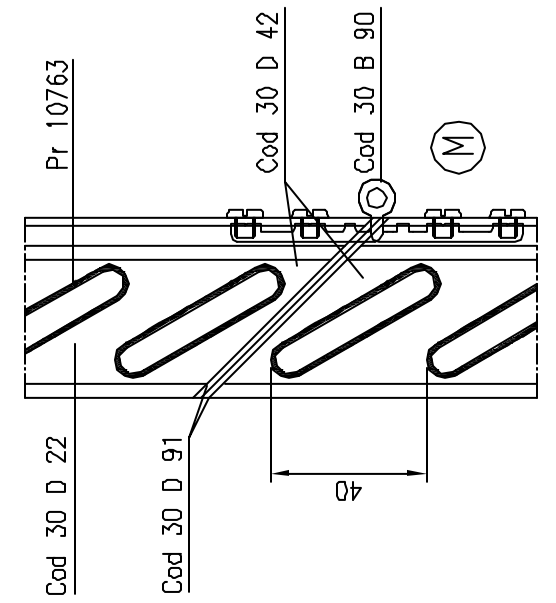
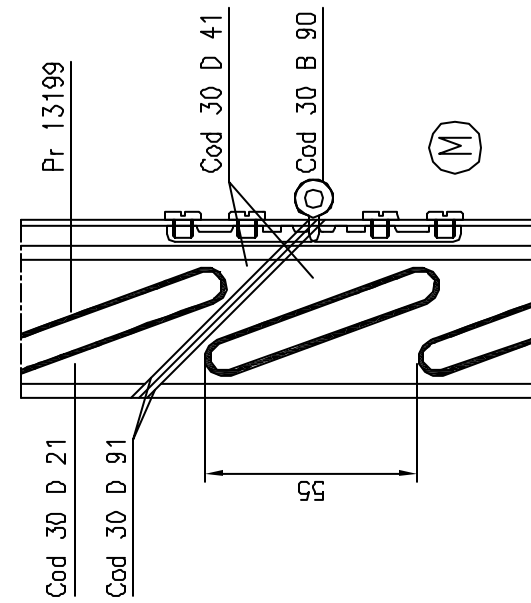

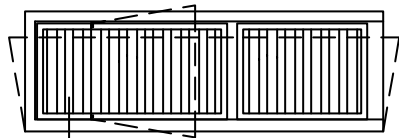

PORTA GELOSIA 1 ANTA

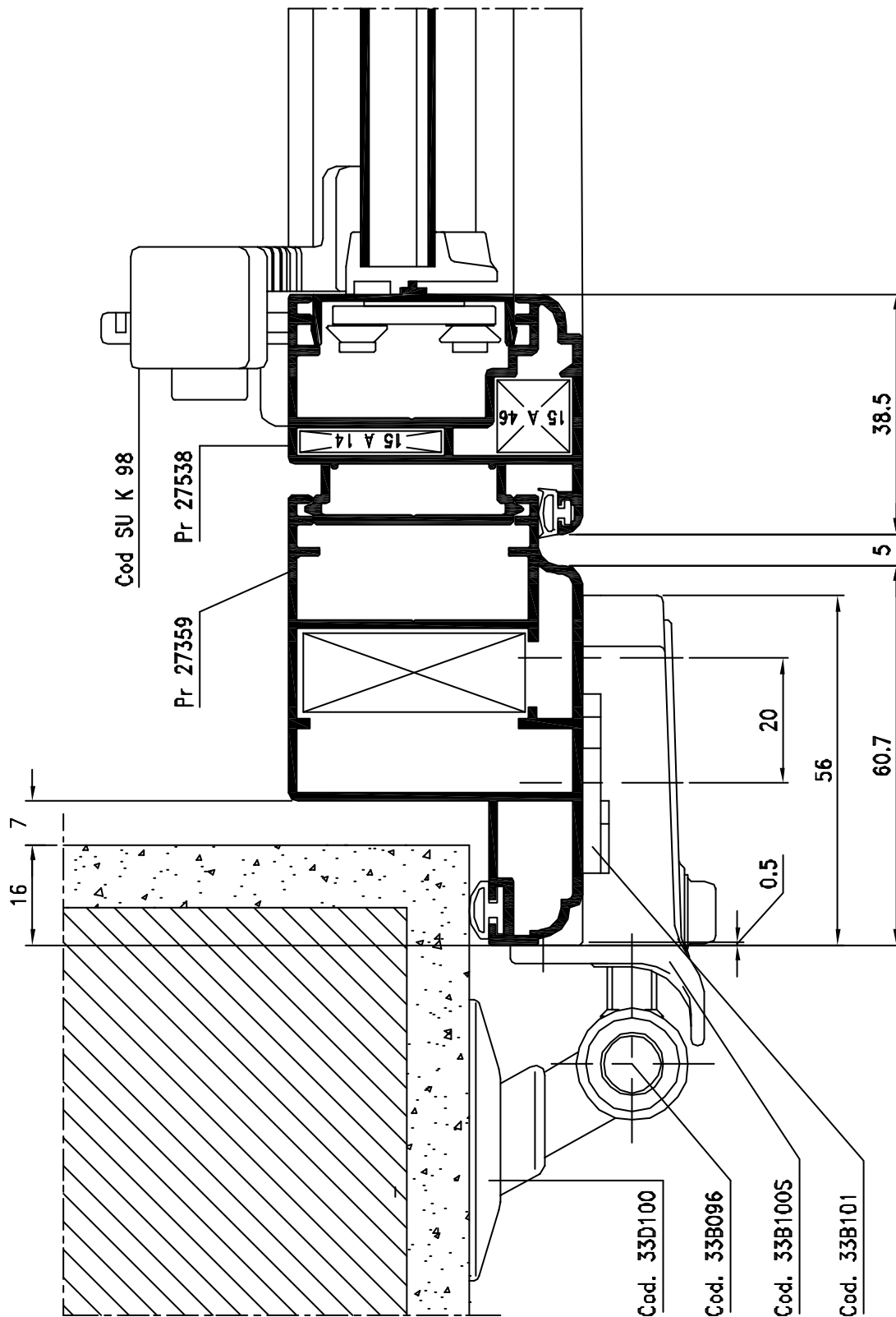

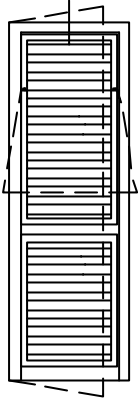

PORTA GELOSIA 1 ANTA

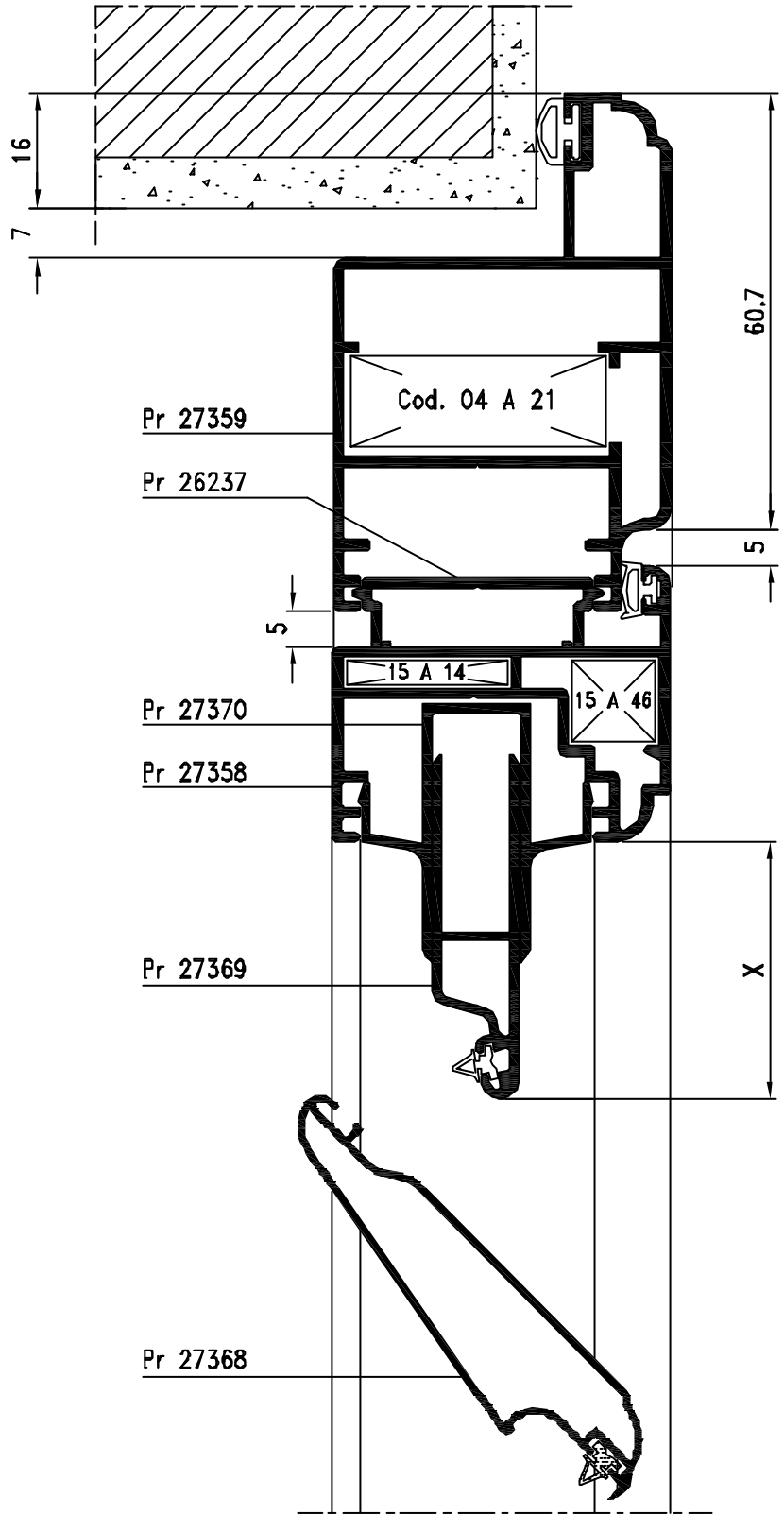

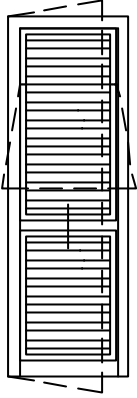

PORTA GELOSIA 1 ANTA

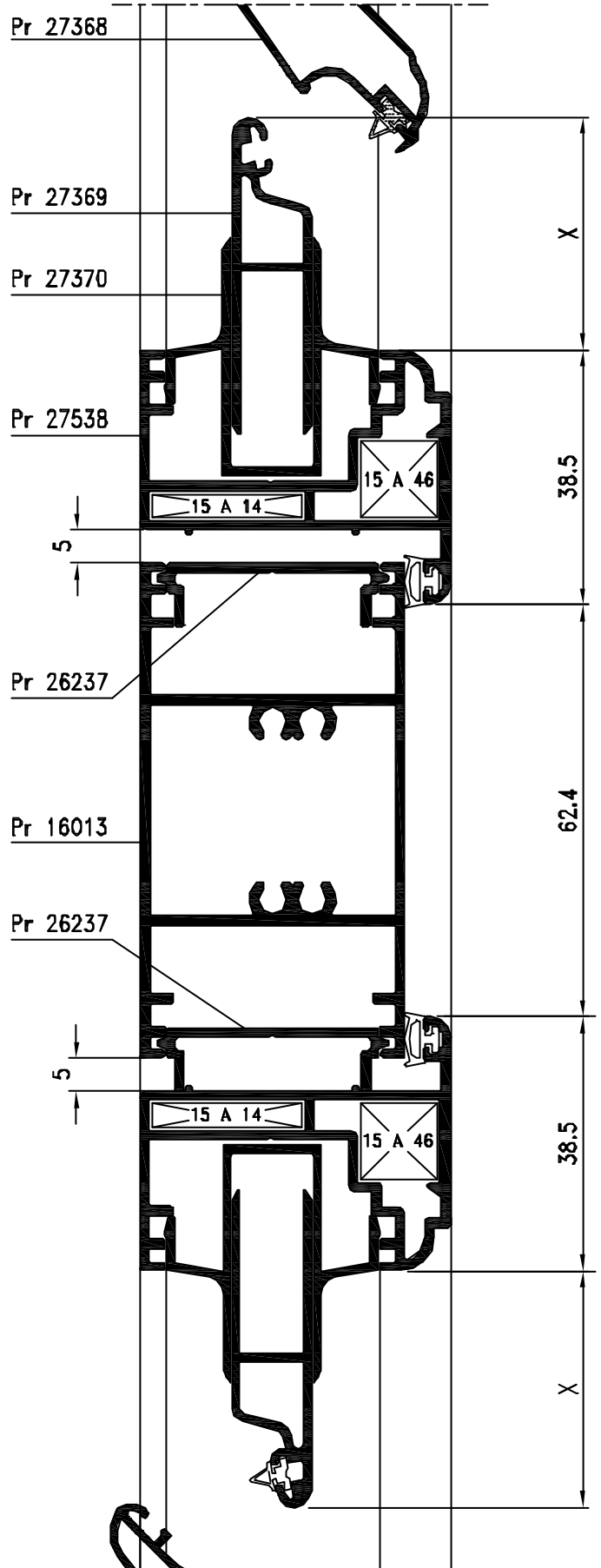

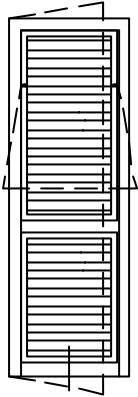

PORTA GELOSIA 1 ANTA

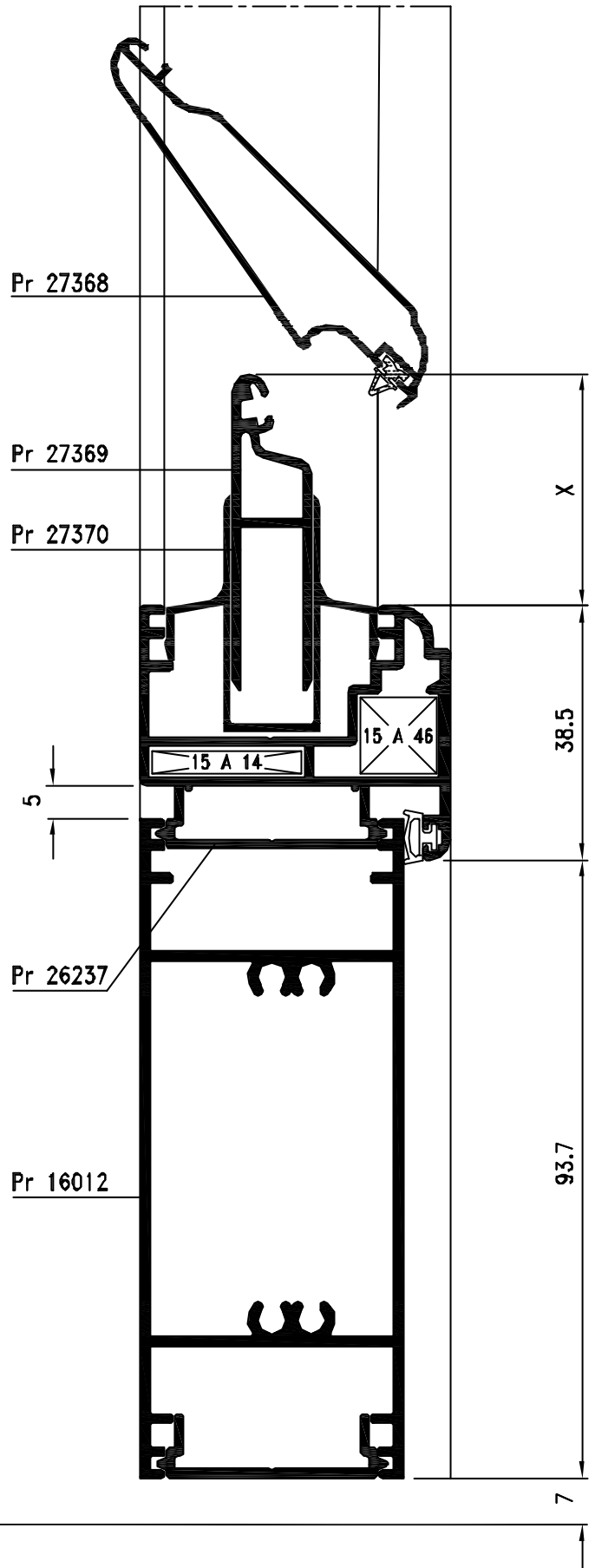

DOMAL SUNNY SCURONI



INDICE SUNNY SCURONI

DESCRIZIONE	da pag.	a pag.
INDICE		177
DESCRIZIONE TECNICA DEL SISTEMA		179
ACCESSORI	181	190
SAGOMARIO PROFILATI	191	192
PROFILATI 1:1	193	195
SCHEMI E DISTINTE	197	200
SEZIONI 1:1		201
LAVORAZIONI		202

DESCRIZIONE TECNICA DEL SISTEMA

PROFILATI ESTRUSI LEGA : EN AW-6060

STATO DI FORNITURA : T5

TOLLERANZE DIMENSIONALI E SPESSORI : EN 12020/2

TIPO DI OSCURAMENTO : DOGHE FISSE

DIMENSIONI DI BASE :

ANTA : PROFONDITA' 44.5 mm.

PROFONDITA' 52.5 mm.

DOGA : 90 x 16 mm.

120 x 9 mm.

70 x 20 mm.

80 x 20 mm.

90 x 20 mm.

FASCIA : 75 x 21.5 mm.

75 x 24.5 mm.

IMPIEGO : E' possibile realizzare SCURONI (finestre e porte)

a battente con 1, 2 o più ante

ACCESSORI	CODICE	COLORE	DESCRIZIONE	MATER.	CONFEZ.
	13 A 19	GREZZO	SQUADRETTA PRESSOFUSA A SCATTO per Pr 27351	ALLUMINIO	PEZZI 300
	13 A 26	GREZZO	SQUADRETTA DI ALLINEAMENTO per Pr 27351	ALLUMINIO	PEZZI 100
	15 A 21	GREZZO	SQUADRETTA PRESSOFUSA A SCATTO per Pr 26218 - 26221	ALLUMINIO	PEZZI 250
	30 D 89	NERO	COPPIA TAPPI per Pr 26219	NYLON	PEZZI 50
	30 D 90	NERO	COPPIA TAPPI per Pr 26225	NYLON	PEZZI 100

ACCESSORI	CODICE	COLORE	DESCRIZIONE	MATER.	CONFEZ.
	30B111D 30B111S	GREZZO RAL9005 RAL8017 RAL6005	CARDINI DX-SX REGISTRABILI PER ANTE SCURONI Pr 26221	ALLUMINIO	PEZZI 20Dx PEZZI 20Sx
	30B114	GREZZO	KIT FISSAGGIO CARDINI	ALLUMINIO	KIT 20
	30B116	GREZZO	TAPPO DI SICUREZZA PER Cod. 30 B 110 Cod. 30 B 111 - 30 B 112 - 30 B 115	OTTONE- ACC.INOX	PEZZI 20
	30B120D 30B120S	GREZZO RAL9005 RAL8017 RAL6005	CARDINI DX-SX PER TERZA ANTA STORICA FISSAGGIO ESTERNO	ALLUMINIO	PEZZI 20Dx PEZZI 20Sx
	30B121	GREZZO RAL9005 RAL8017 RAL6005	CARDINI DX-SX A SQUADRO PER ANTA STORICA FISSAGGIO ESTERNO CON PERNO REGOLABILE	ALLUMINIO	COPPIA 10

ACCESSORI	CODICE	COLORE	DESCRIZIONE	MATER.	CONFEZ.
	33B091	RAL9005	SUPPORTO CERNIERA PER Cod. 33B092	ZAMA	PEZZI 20
	33B092	RAL9005	CERNIERA REGOLABILE COLLO ALTO	ZAMA	PEZZI 20
	33B093 D	RAL9005	CERNIERA REGOLABILE 19x8 DX COLLO 19x35mm	ZAMA	PEZZI 20
	33B093 S	RAL9005	CERNIERA REGOLABILE 19x8 SX COLLO 19x35	ZAMA	PEZZI 20
	33B094 D	RAL9005	CERNIERA REGOLABILE 45x8 DX COLLO 45x35mm	ZAMA	PEZZI 20
	33B094 S	RAL9005	CERNIERA REGOLABILE 45x8 SX COLLO 45x35mm	ZAMA	PEZZI 20
	33B095	RAL9005	CARDINE 85mm REGOLABILE FISSAGGIO A TASSELLO	ACCIAIO	PEZZI 20
	33B096	RAL9005	CARDINE 125mm REGOLABILE FISSAGGIO A TASSELLO	ACCIAIO	PEZZI 20





ACCESSORI	CODICE	COLORE	DESCRIZIONE	MATER.	CONFEZ.
	33B097	RAL9005	CARDINE 145mm REGOLABILE FISSAGGIO A TASSELLO	ACCIAIO	PEZZI 20
	33B098	RAL9005	CARDINE 175mm REGOLABILE FISSAGGIO A TASSELLO	ACCIAIO	PEZZI 20
	33B099 D	RAL9005	CERNIERA REGOLABILE 45x8 DX COLLO 45x26mm	ZAMA	PEZZI 20
	33B099 S	RAL9005	CERNIERA REGOLABILE 45x8 SX COLLO 45x26	ZAMA	PEZZI 20
	33B100 D	RAL9005	CERNIERA REGOLABILE 19x8 DX COLLO 19x26mm	ZAMA	PEZZI 20
	33B100 S	RAL9005	CERNIERA REGOLABILE 19x8 SX COLLO 19x26mm	ZAMA	PEZZI 20
	33B101	RAL9005	BANDELLA VERTICALE PER CERNIERA	ACCIAIO	PEZZI 20
	33B102	RAL9005	SQUADRO PER CERNIERA SUPERIORE SX. - INFERIORE DX.	ACCIAIO	PEZZI 20



ACCESSORI	CODICE	COLORE	DESCRIZIONE	MATER.	CONFEZ.
	33B103	RAL9005	SQUADRO PER CERNIERA SUPERIORE DX. - INFERIORE SX.	ACCIAIO	PEZZI 20
	33B108	RAL9005	CARDINE 85mm FISSAGGIO A TASSELLO	ACCIAIO	PEZZI 20
	33B109	RAL9005	CARDINE 125mm FISSAGGIO A TASSELLO	ACCIAIO	PEZZI 20
	33B110	RAL9005	CARDINE 145mm FISSAGGIO A TASSELLO	ACCIAIO	PEZZI 20
	33B111	RAL9005	CARDINE 175mm FISSAGGIO A TASSELLO	ACCIAIO	PEZZI 20
	33B112	RAL9005	CARDINE A MURARE	ACCIAIO	PEZZI 6
	33C099	RAL9005	CONFEZIONE BASE SPAGNOLETTA GRANDE 2 ANTE	ZAMA	PEZZI 20
	33C100	RAL9005	CONFEZIONE BASE SPAGNOLETTA PICCOLA 2 ANTE	ZAMA	PEZZI 20











ACCESSORI	CODICE	COLORE	DESCRIZIONE	MATER.	CONFEZ.
	33C101	RAL9005	CONFEZIONE BASE SPAGNOLETTA PICCOLA 1 ANTA	ZAMA	PEZZI 20
	33C102	RAL9005	CONFEZIONE BASE SPAGNOLETTA A SCATTO	ZAMA	PEZZI 20
	33C103	RAL9005	PERNO DI CHIUSURA DIRITTO	ZAMA	PEZZI 50
	33C104	RAL9005	PIASTRA DI CHIUSURA AD ANGOLO	ACCIAIO	PEZZI 20
	33C105	RAL9005	GUIDA ASTE	ZAMA	PEZZI 50
	33C106	RAL9005	CHIUSURA VERTICALE AD ESPANSIONE DX. CONFEZIONE BASE	ZAMA/ACC.	PEZZI 20
	33C107	RAL9005	CHIUSURA VERTICALE AD ESPANSIONE SX. CONFEZIONE BASE	ZAMA/ACC.	PEZZI 20
	33C108	RAL9005	COMPENSATORE DI ROTAZIONE 180° DX. PER Cod. 33C106	ZAMA	PEZZI 50

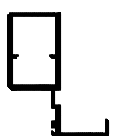

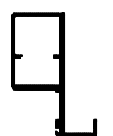

ACCESSORI	CODICE	COLORE	DESCRIZIONE	MATER.	CONFEZ.
	33C109	RAL9005	COMPENSATORE DI ROTAZIONE 180° SX. PER Cod. 33C107	ZAMA	PEZZI 50
	33C110	RAL9005	POZZETTO PER SOGLIA	ZAMA	PEZZI 50
	33C111	RAL9005	LAMA DI AGGANCIO PER IMPOSTA	ACCIAIO	PEZZI 20
	33C112	RAL9005	FERMOIMPOSTA AUTOMATICO A MURO	ZAMA	PEZZI 20
	33C116	RAL9005	ASTA DI CHIUSURA 1800mm	ACCIAIO	PEZZI 10
	33C117	RAL9005	ASTA DI CHIUSURA 2400mm	ACCIAIO	PEZZI 10
	33C118	RAL9005	ASTA DI CHIUSURA 3200mm	ACCIAIO	PEZZI 10
	33C130	RAL9005	PERNO DI CHIUSURA M8	ACCIAIO	PEZZI 50

ACCESSORI	CODICE	COLORE	DESCRIZIONE	MATER.	CONFEZ.
	33C131	RAL9005	PERNO DI CHIUSURA Ø10 DA INCOLLARE	ACCIAIO	PEZZI 50
	33C132	RAL9005	PERNO DI CHIUSURA ECCENTRICO	ACC.-ABS	PEZZI 10
	33D100	RAL9005	ROSETTA COPRIFORO CARDINE	ABS	PEZZI 100
	33D101	GREZZO	TASSELLO 100mm	ABS	PEZZI 50
	33D102	GREZZO	TASSELLO 135mm	ABS	PEZZI 50
	33W100		KIT DIME PER IMPOSTE A MURARE	ACCIAIO	PEZZI 1

SEZIONE	CODICE	DESCRIZIONE	BOBINE m	SCATOLA m
	90 G 22	GUARNIZIONE DI BATTUTA MATERIALE: EPDM COLORE: NERO rabbet gasket material: epdm colour: black	200	
	90 G 31	GUARNIZIONE DI BATTUTA MATERIALE: EPDM COLORE: NERO rabbet gasket material: epdm colour: black	DOPPIA 400	
	90 G 122	GUARNIZIONE DI BATTUTA H=10mm MATERIALE: ELAPRENE COLORE: NERO rabbet gasket material: elaprene colour: black	200	
	90 G 123	GUARNIZIONE DI BATTUTA H=6.7mm MATERIALE: ELAPRENE COLORE: NERO rabbet gasket material: elaprene colour: black	150	
	90 S 57	SPAZZOLINO DA 5 x 11 per PR 26219 MATERIALE: POLIPROPILENE COLORE: GRIGIO shutterpyle 5x11 for PR 26219 material: polypr. colour: grey	200	400

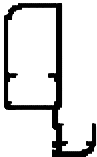
ATTREZZATURE	CODICE	DESCRIZIONE	CONFEZ.
	13 W 76	PUNZONATRICE per SQUADRETTA 13 A 19	PEZZI 1
	13 W 83	PUNZONATRICE per SQUADRETTA 15 A 21	PEZZI 1

SEZIONE	CODICE	PESO Kg/m.	SUP. IN VISTA mm.	PAGINA	DESCRIZIONE
	Pr 07220	1,084	187	B02	PROFILATO DOGA mm. 23,5
	Pr 23338	0,937	248	B02	PROFILATO DOGA mm. 120 x 9
	Pr 26218	0,791	105	B01	PROFILATO ANTA PER PANNELLATURA ISOLATA
	Pr 26219	0,375	50	B01	PROFILATO DI RIPORTO PER PORTE
	Pr 26221	0,756	94	B01	PROFILATO ANTA
	Pr 26224	0,712	182	B02	PROFILATO DOGA CENTRALE mm. 90 x 16
	Pr 26225	0,526	99	B01	PROFILATO DI RIPORTO CENTRALE (STULP)
	Pr 26226	0,876	192	B03	PROFILATO DOGA TERMINALE mm. 80 x 20
	Pr 26227	0,910	206	B03	PROFILATO DOGA CENTRALE mm. 80 x 20
	Pr 26231	0,991	216	B03	PROFILATO DOGA CENTRALE mm. 90 x 20

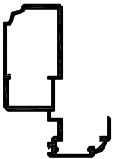
SEZIONE	CODICE	PESO Kg/m.	SUP. IN VISTA mm.	PAGINA	DESCRIZIONE
	Pr 27346	1,604	204	B02	PROFILATO DOGA A TAGLIO TERMICO mm. 110 x 24
	Pr 27348	0,972	120	B01	PROFILATO ANTA SAGOMATA PER DOGA Pr 26224
	Pr 27351	0,724	10	B03	PROFILATO FASCIA
	Pr 27352	0,527	113	B03	PROFILATO COPERTINA PER Pr 27351
	Pr 27353	0,143	28	B03	PROFILATO CHIUDI TUBOLARITA'
	Pr 27356	0,829	142	B03	PROFILATO DOGA CENTRALE mm. 70 x 20
	Pr 50051	0,988	149	B01	PROFILATO ANTA SAGOMATA PER DOGA Pr 27346

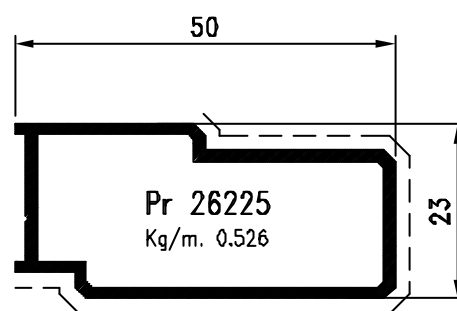
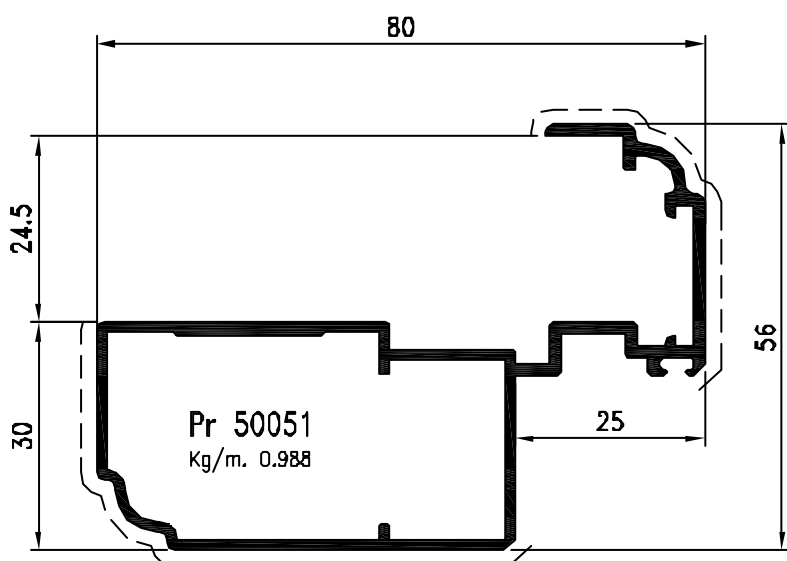
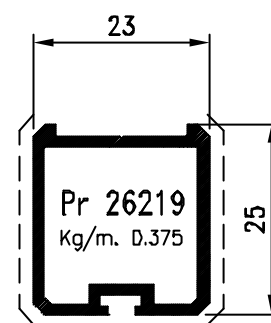
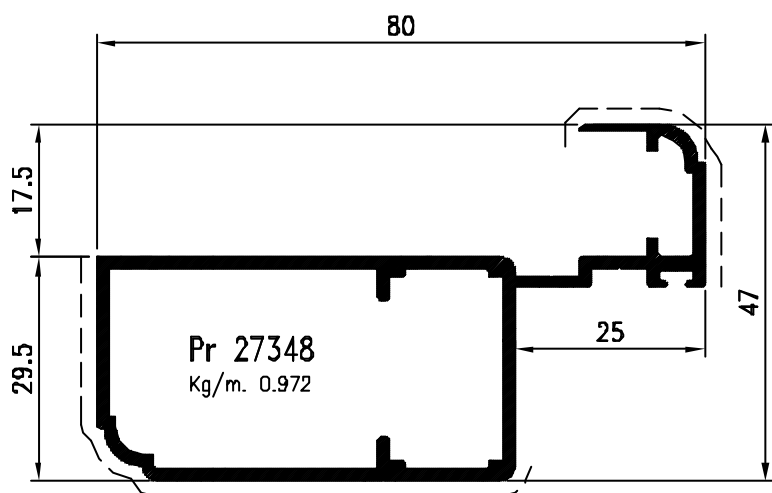
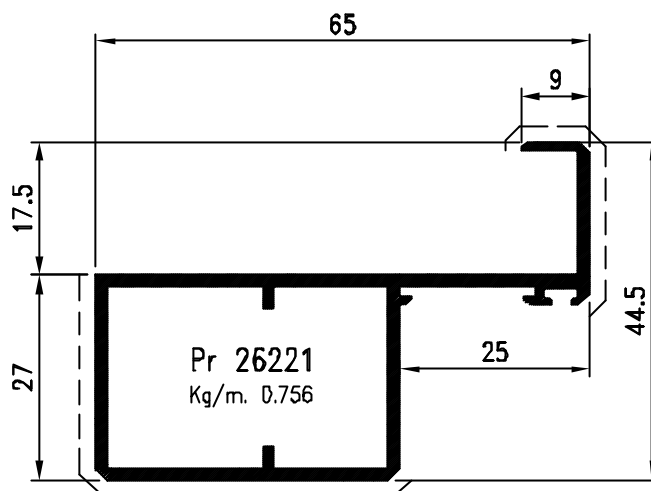
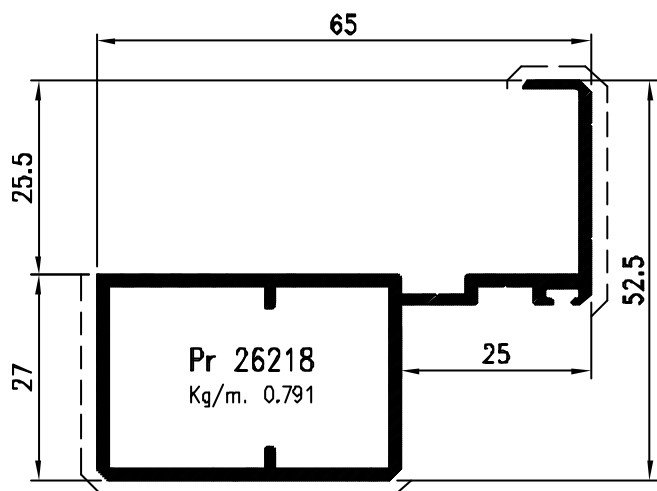

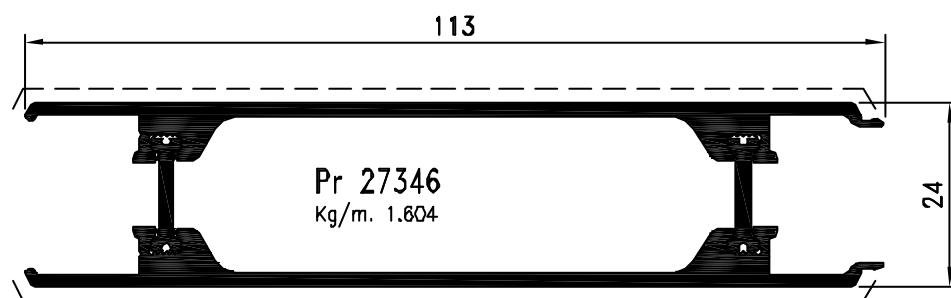
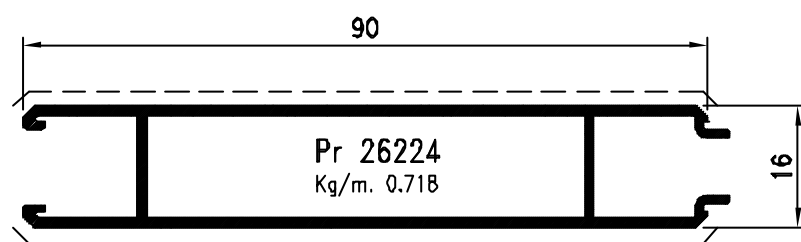
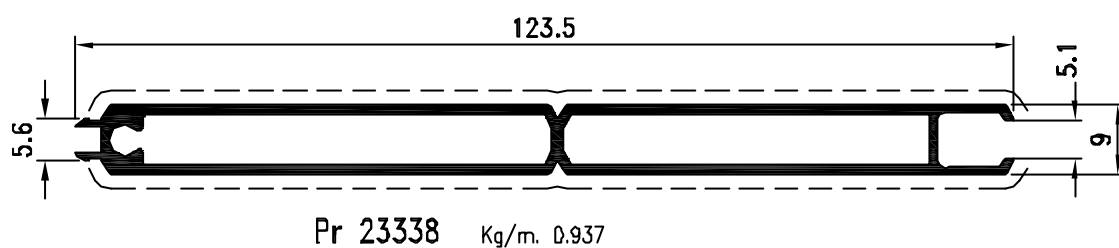
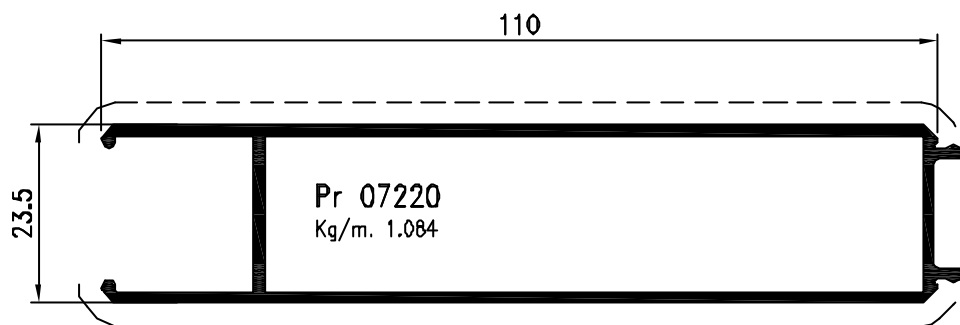

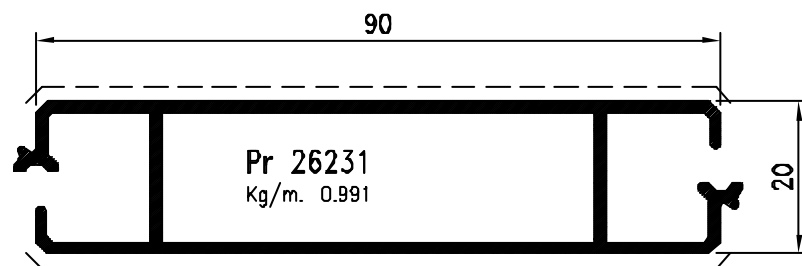
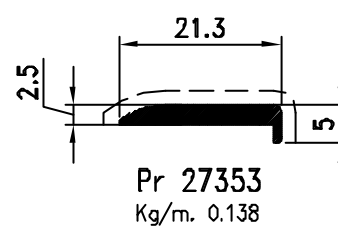
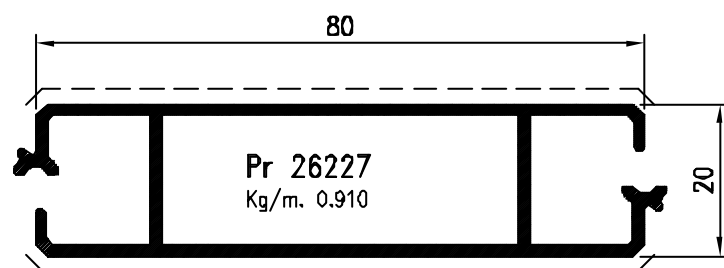
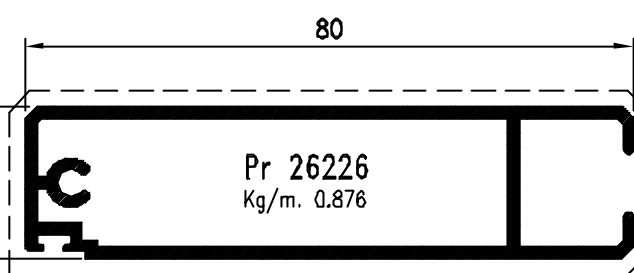
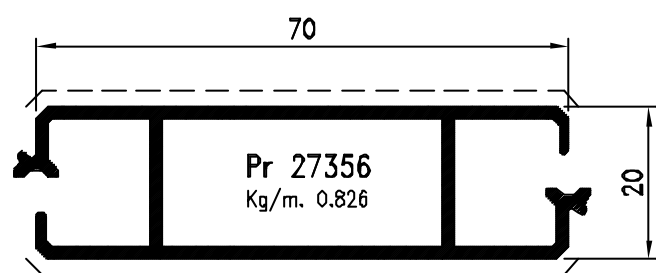
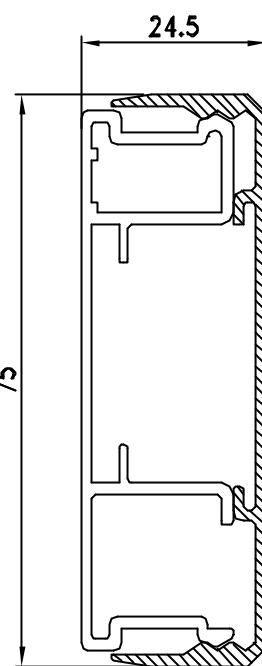
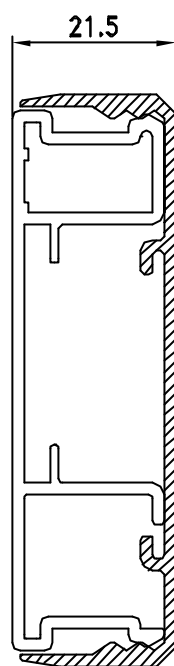
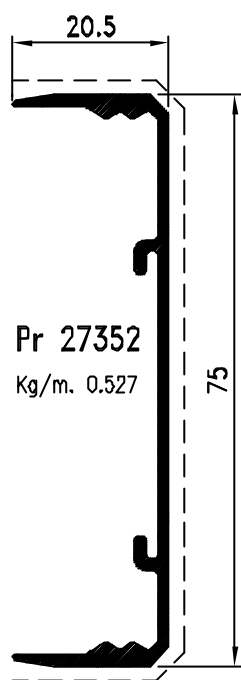
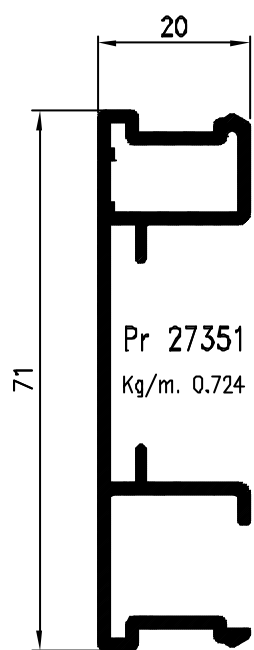

PROSPETTO ESTERNO

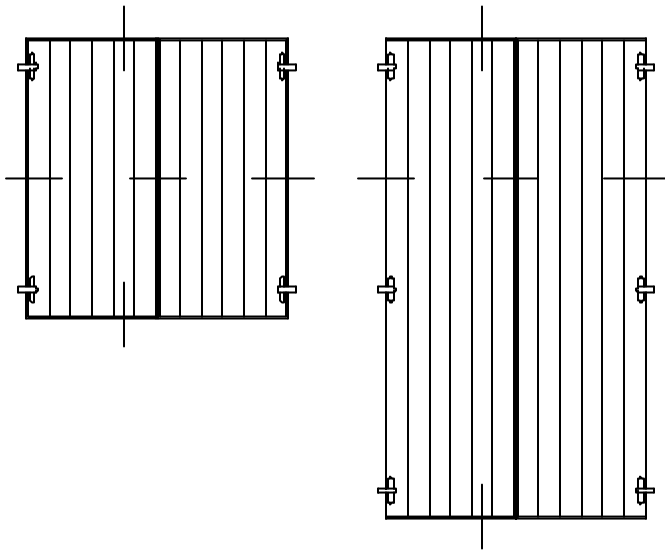

FINESTRA

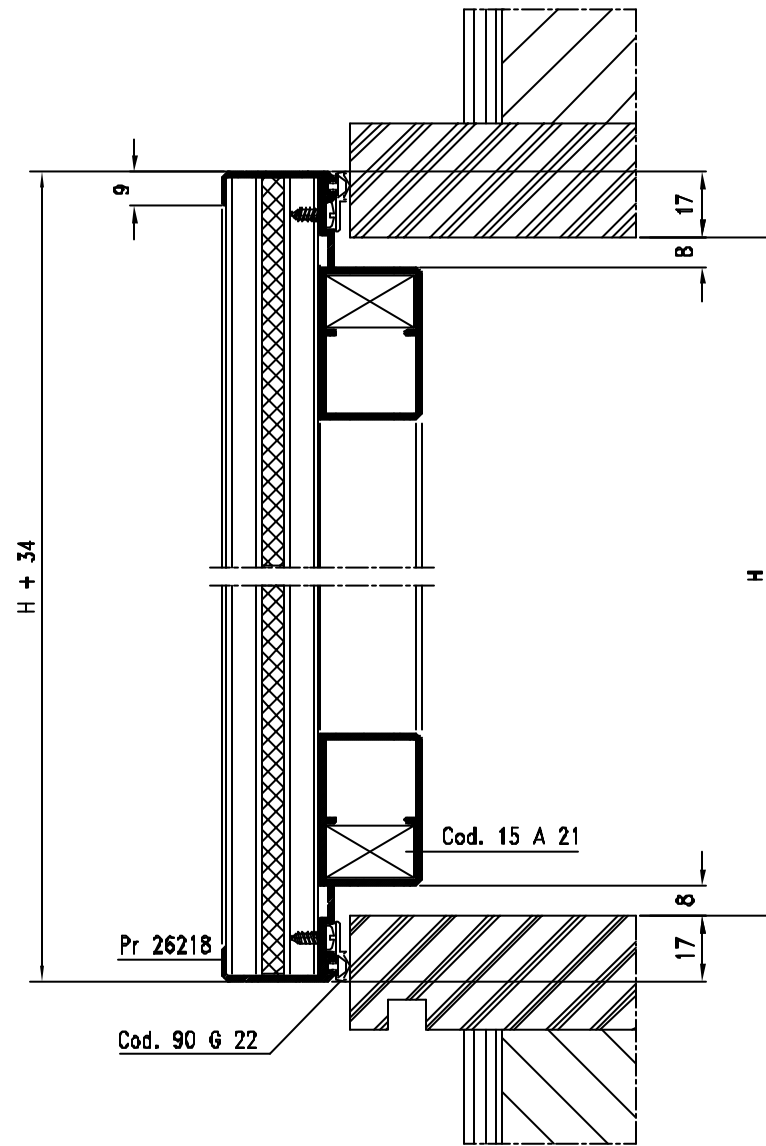

PORTA

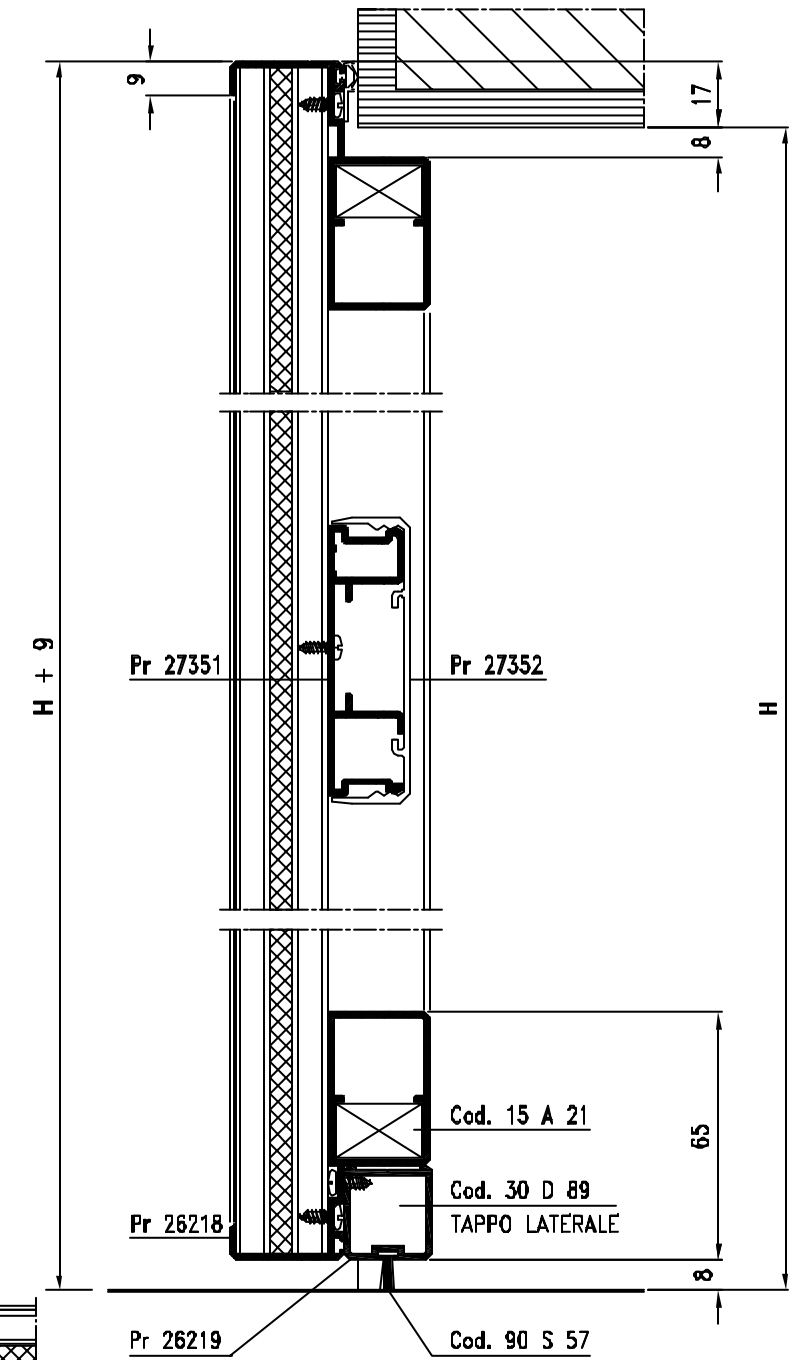

Cod. 33 B 094D

Cod. 33 B 101

$L/2 + 13.5$

ISOLANTE SPESS. 6 mm.

120

Pr 23338

TAPPO
Cod. 30 D 90

Cod. 15 A 21

Cod. 30 D 89
TAPPO LATERALE

17 8 40

$L/2 - 116.5$
Misura TRAVERSO

Cod. 33 C 099

Pr 26225

L

PROSPETTO ESTERNO

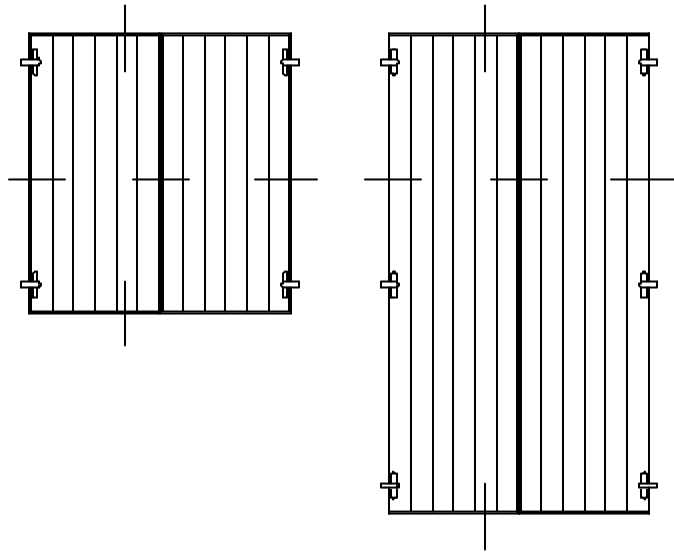

FINESTRA

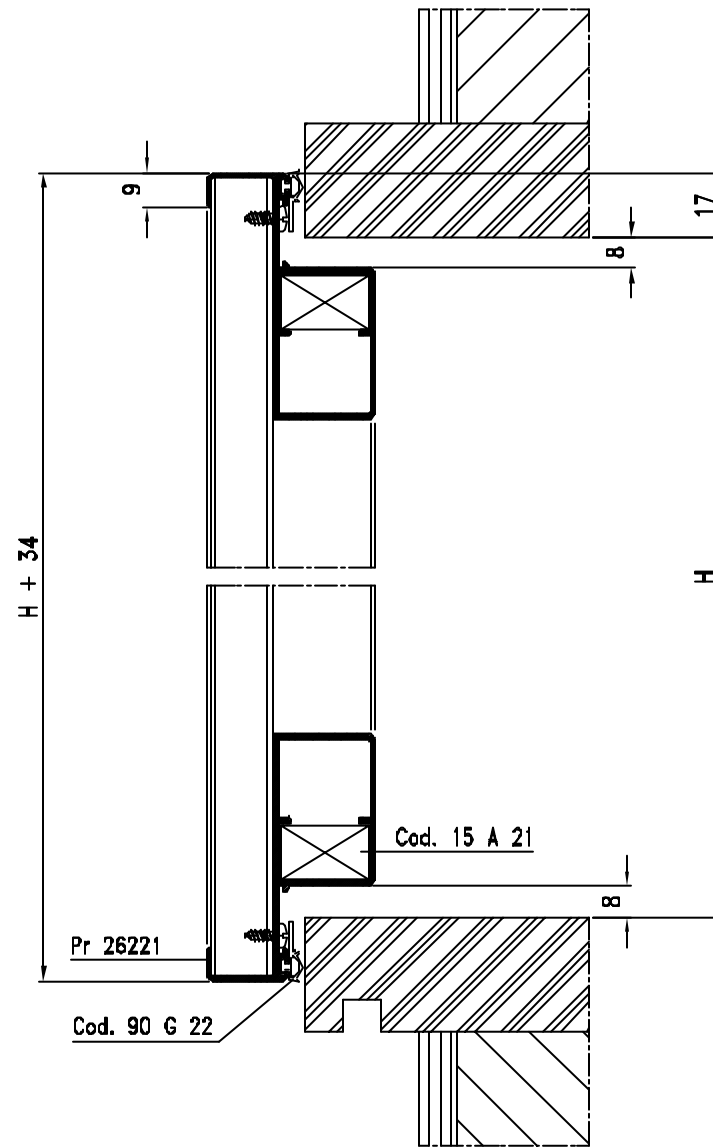

PORTA

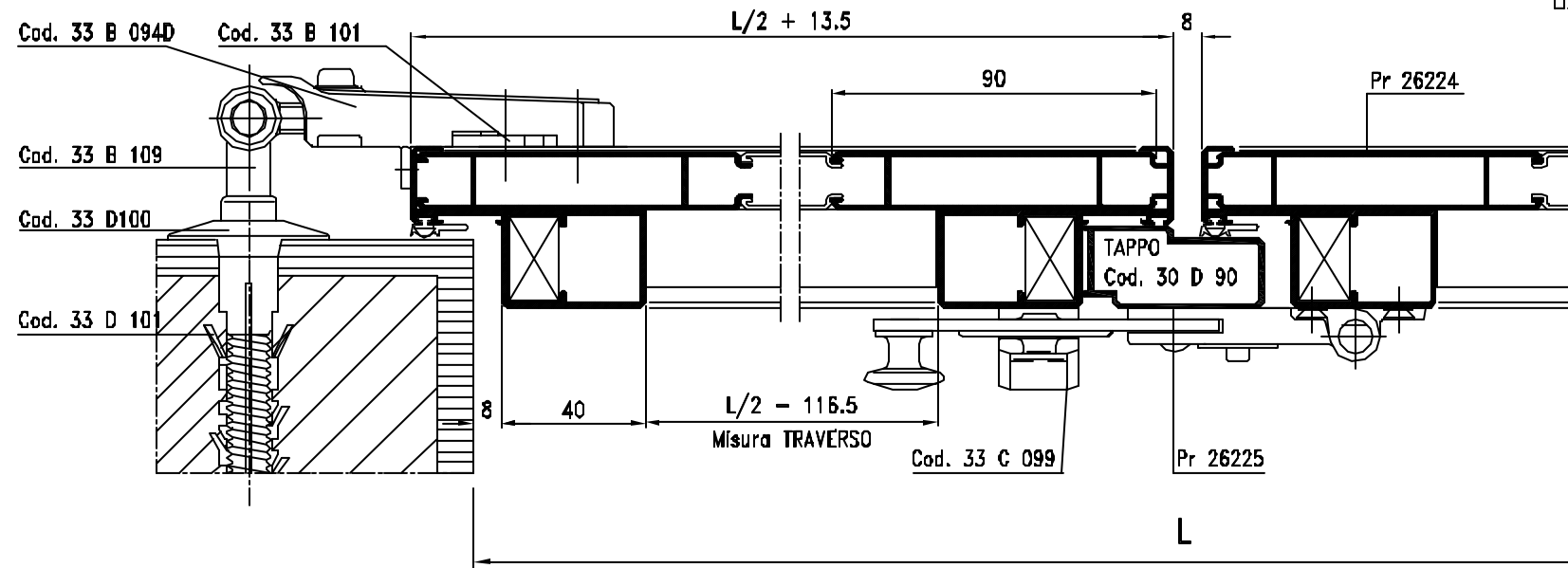
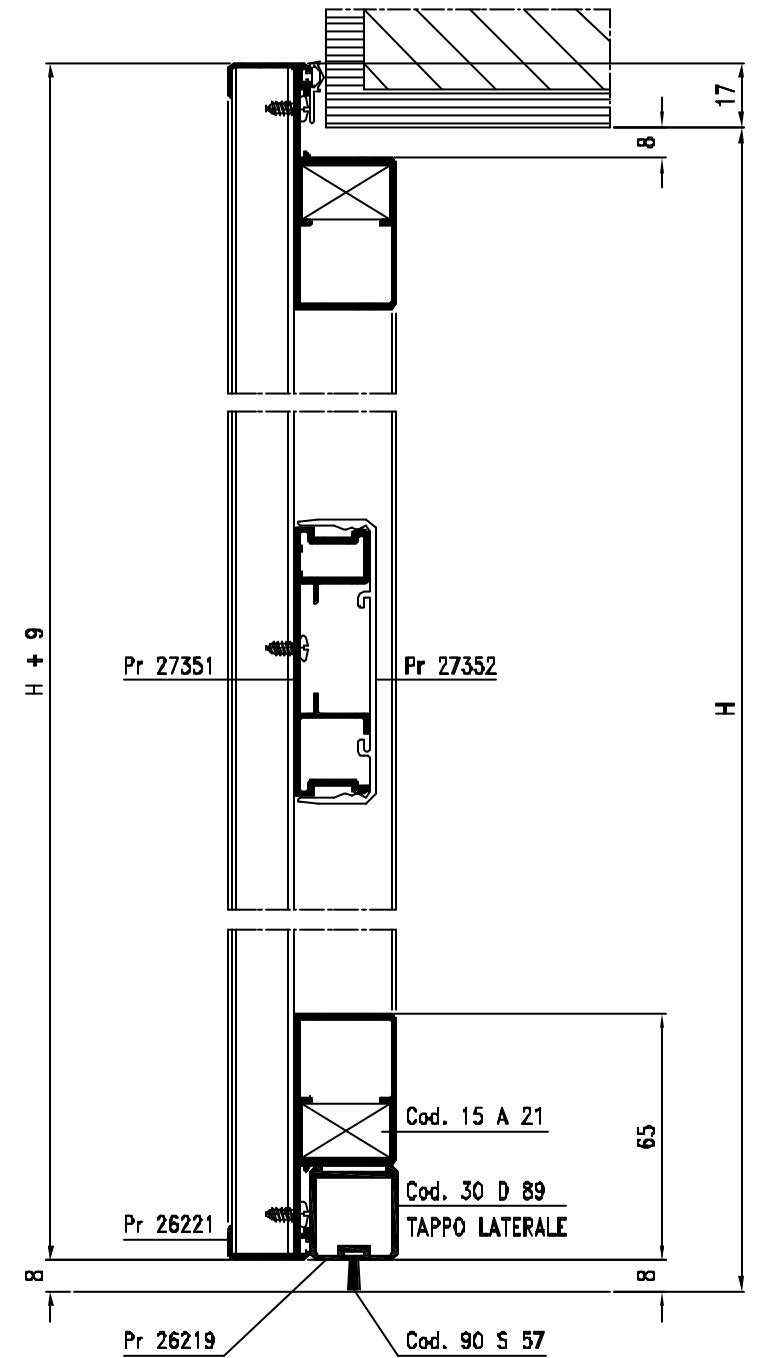

PROSPETTO ESTERNO

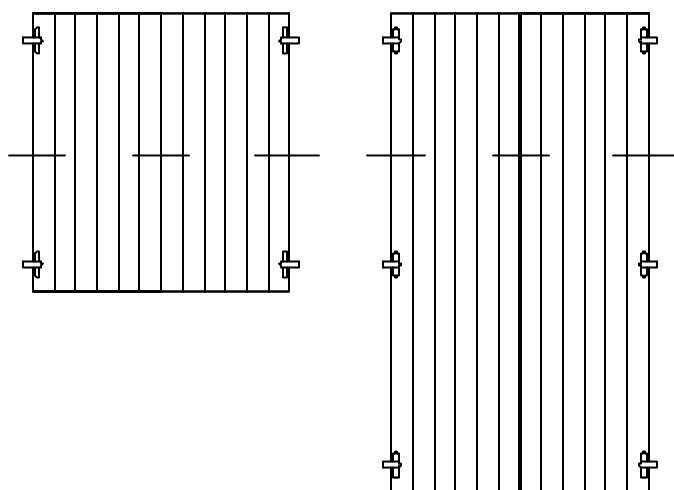

LE SEZIONI VERTICALI SONO A PAG. C 04

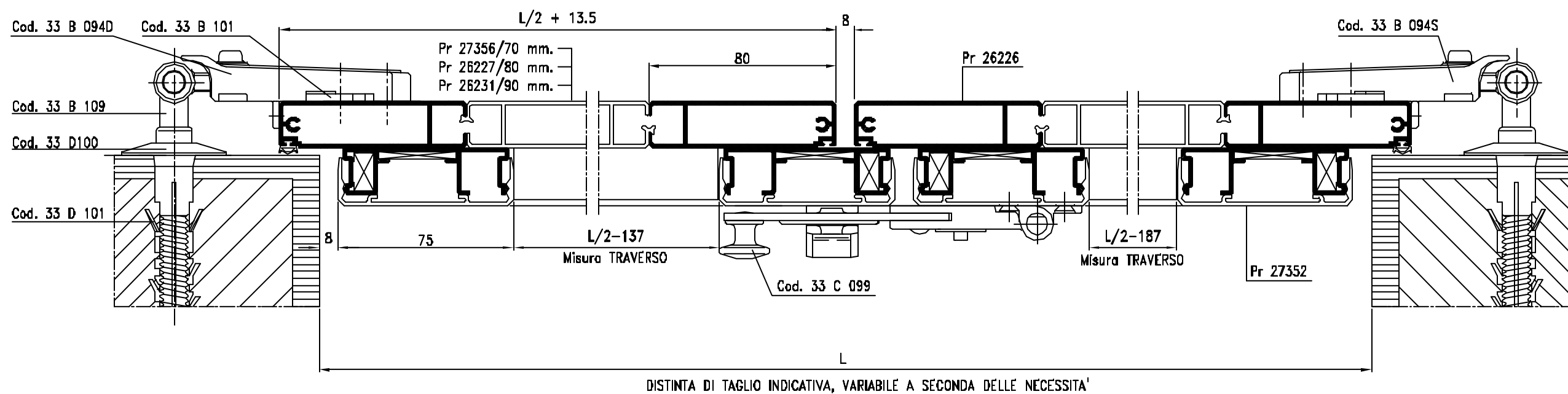

PROSPETTO ESTERNO
FINESTRA

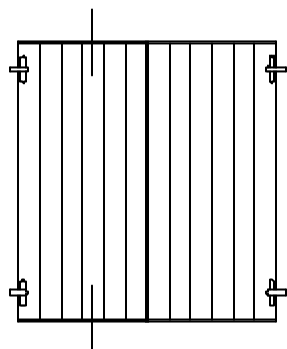

PROSPETTO ESTERNO
PORTA

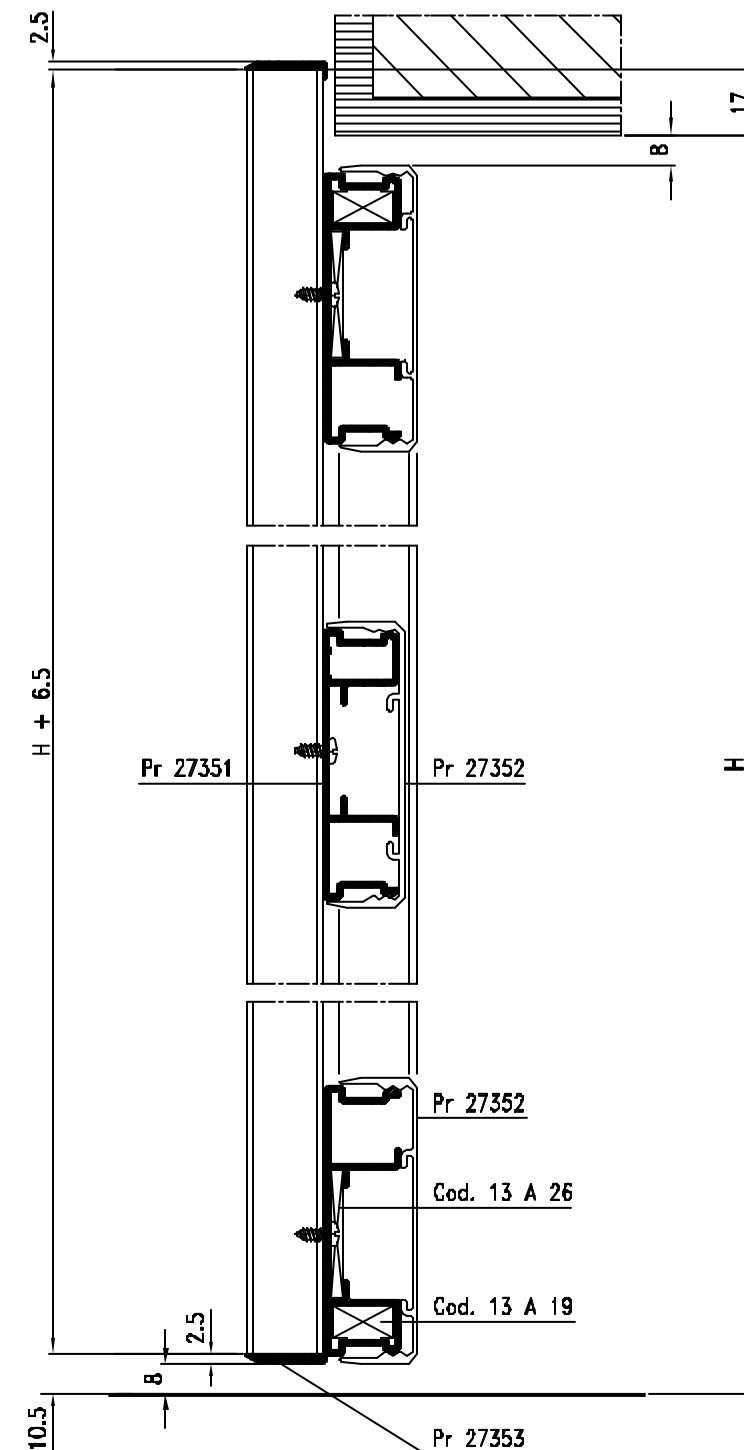
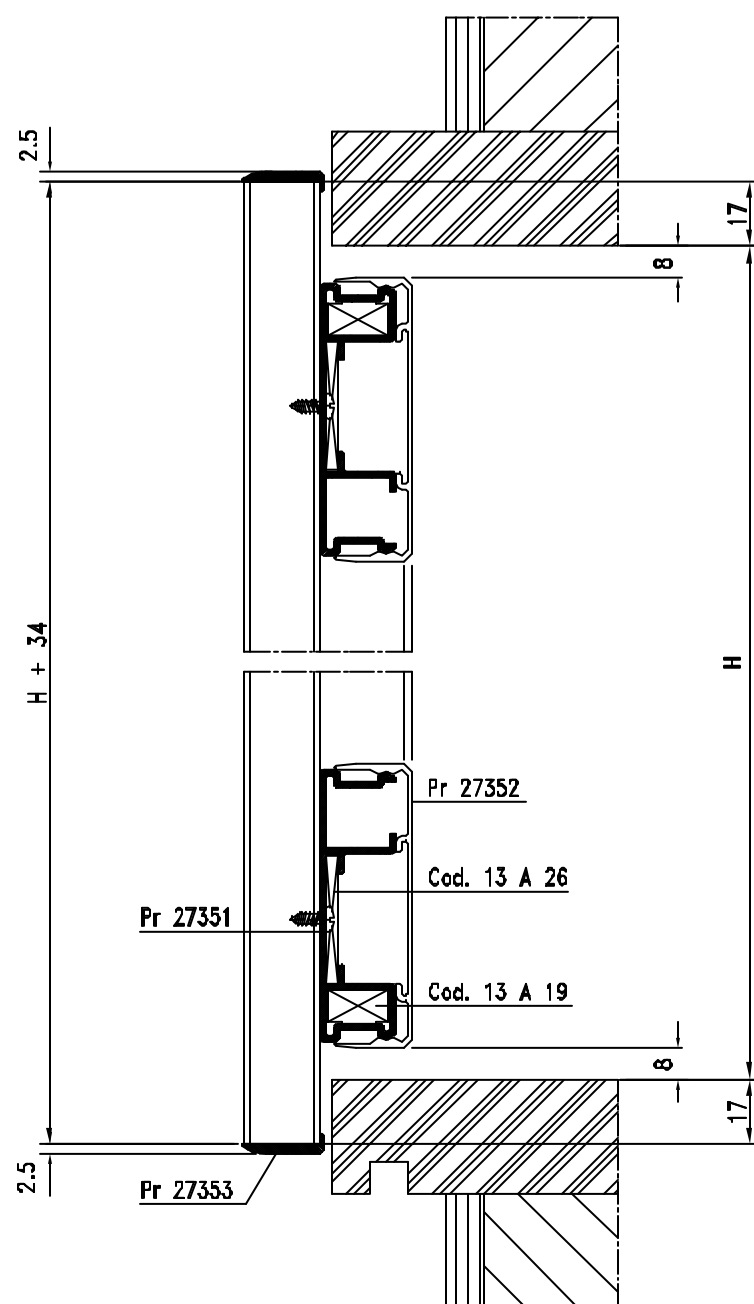
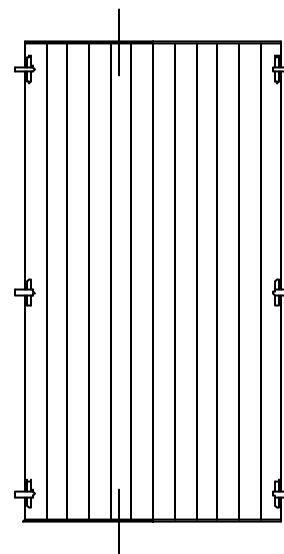

LA SEZIONE ORIZZONTALE E' A PAG. C 03

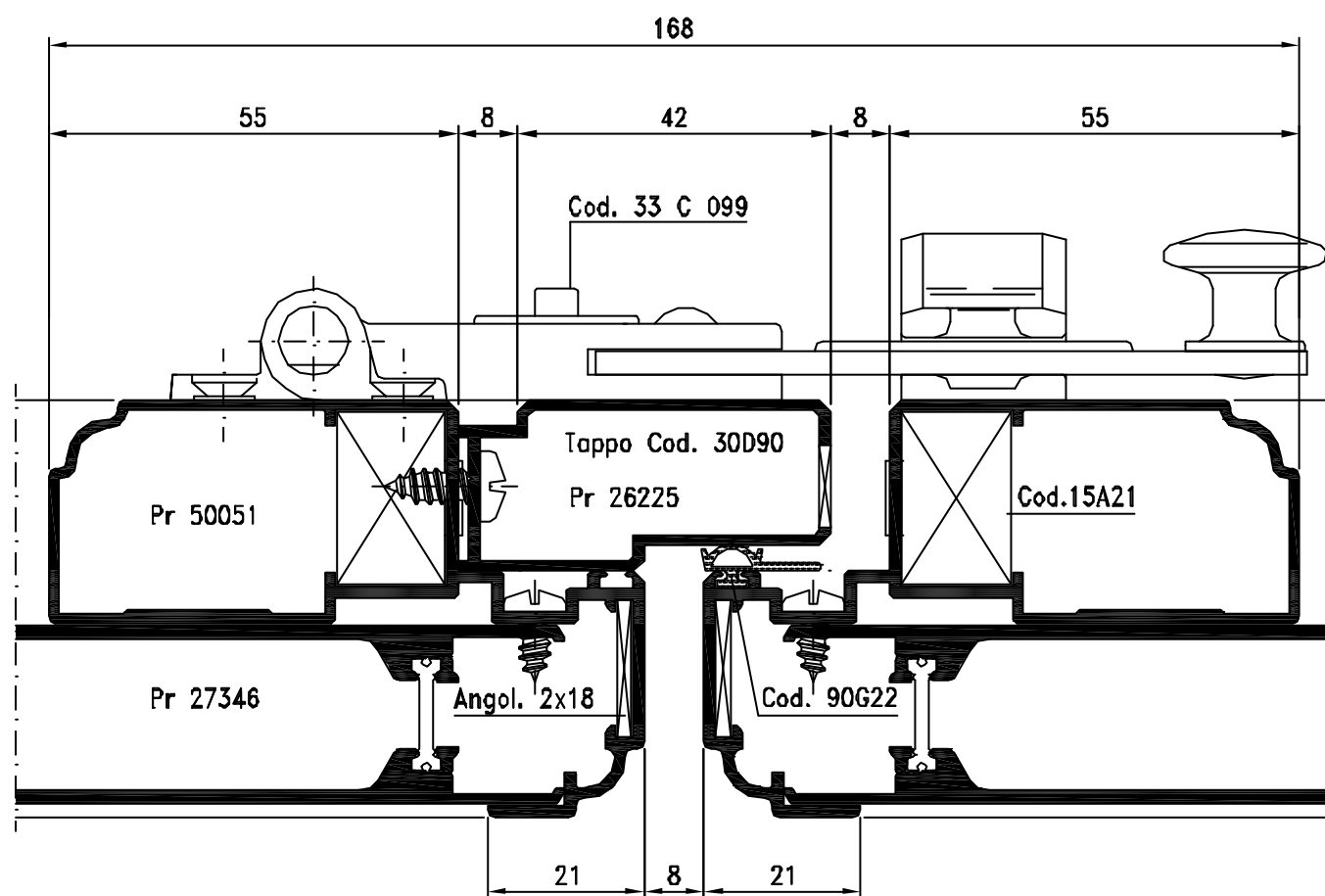
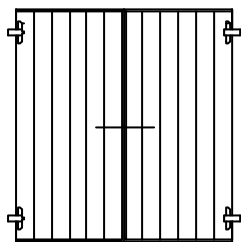

SOLUZIONE CON DOGHE AUTOPORTANTI DA 20 mm. COMPOSIZIONE DOGHE

Dim.ANTA mm.	Pr 26226 TERMINALE	Pr 27356 DOGA 70mm.	Pr 26227 DOGA 80mm.	Pr 26231 DOGA 90mm.	Dim.ANTA mm.	Pr 26226 TERMINALE	Pr 27356 DOGA 70mm.	Pr 26227 DOGA 80mm.	Pr 26231 DOGA 90mm.
230	2	1	—	—	570	2	—	4	1
240	2	—	1	—	580	2	—	3	2
250	2	—	—	1	590	2	—	2	3
260 *					600	2	—	1	4
270 *					610	2	—	—	5
280 *					620	2	2	4	—
290 *					630	2	2	3	1
300	2	2	—	—	640	2	—	6	—
310	2	1	1	—	650	2	—	5	1
320	2	—	2	—	660	2	—	4	2
330	2	—	1	1	670	2	—	3	3
340	2	—	—	2	680	2	—	2	4
350 *					690	2	—	1	5
360 *					700	2	—	—	6
370	2	3	—	—					
380	2	2	1	—					
390	2	2	—	1					
400	2	—	3	—					
410	2	—	2	1					
420	2	—	1	2					
430	2	—	—	3					
440	2	4	—	—					
450	2	3	1	—					
460	2	2	2	—					
470	2	2	1	1					
480	2	—	4	—					
490	2	—	3	1					
500	2	—	2	2					
510	2	—	1	3					
520	2	—	—	4					
530	2	3	2	—					
540	2	3	1	1					
550	2	3	—	2					
560	2	—	5	—					

N.B.:
RISPETTO A QUANTO INDICATO, ALCUNE
DIMENSIONI POTRANNO ESSERE COSTRUITE
CON UNA DIVERSA COMPOSIZIONE DI DOGHE

* DIMENSIONI NON REALIZZABILI

C A T A L O G O

DOMAL SUNNY VENETA

Hydro
Building
Systems



INDICE

DESCRIZIONE	da pag.	a pag.
INDICE		01
NOTE GENERALI		02
CONSIGLI PRATICI		03
DESCRIZIONE TECNICA DEL SISTEMA		04
ACCESSORI	A 01	A 06
GUARNIZIONI	A 07	
ATTREZZATURE		A 08
SAGOMARIO PROFILATI	A 09	A 11
PROFILATI 1:1	B 01	B 04
DISTINTE	C 01	C 07
LAVORAZIONI	E 01	E 02
APPLICAZIONI ACCESSORI (CERNIERE)		F 01
SCHEMI-COMPOSIZIONI PANNELLI E PESI TEORICI	G 01	G 04

CATALOGO GRATUITO NON DESTINATO ALLA VENDITA.

Note Generali

Peso profilati guarnizioni:

Il peso riportato sul catalogo per i profilati e le guarnizioni è quello teorico quindi potrà variare in funzione delle tolleranze dimensionali e di spessore regolamentate dalle norme EN.

(Norma EN 12020/2 per i profilati e norma UNI 9122 per le guarnizioni).

Leghe di estrusione:

I profilati sono estrusi in lega EN AW 6060 con stato di fornitura T5.

Lunghezza delle barre:

La lunghezza commerciale delle barre dei profilati è di mm6.500.

Per eventuali dimensioni differenti contattare i servizi commerciali.

Dimensione dei profilati:

Le dimensioni riportate per i profilati sono quelle teoriche quindi potranno variare, in modo più o meno evidente, a causa delle tolleranze di estrusione. (Norma EN 12020/2).

Detta variabilità può risultare più evidente nelle varie cavità previste per l'inserimento di accessori e guarnizioni.

Anche i vari accoppiamenti possono risentire di queste variazioni dimensionali.

Le cave piccole, in particolare quelle delle guarnizioni, possono essere sensibilmente ridotte, nel caso di profilati verniciati, dallo spessore della vernice stessa.

Dimensioni di taglio:

Nel presente catalogo sono riportate delle distinte di taglio e degli schemi di lavorazione.

Le dimensioni teoriche riportate sono esatte ma in pratica dovranno essere considerati quegli arrotondamenti che la tecnica e l'attrezzatura della propria officina consiglia.

Costruzione dei serramenti:

Si consiglia nei primi lavori o prima di iniziare lavori quantitativamente importanti, di realizzare un campione in dimensioni reali al fine di controllarne, gli assiamaggi, le prestazioni agli agenti atmosferici e le caratteristiche meccaniche degli accessori.

Riferimento quote:

Il riferimento delle quote L ed H del catalogo, corrisponde ai riferimenti che in genere sono riportati anche sulle troncatrici. In caso diverso apportare le opportune correzioni.

Schemi, sezioni e collegamenti al muro:

Gli schemi, le sezioni e gli attacchi a muro riportati sul catalogo non hanno valore limitativo ma solo di esemplificazione di alcune delle situazioni che più comunemente si trovano nella realtà e di soluzione consigliabile.

Tolleranza di posa in opera:

Trà l'interno del controtelaio in acciaio e l'esterna della parte tubolare del serramento è consigliabile lasciare uno spazio o tolleranza di posa di circa mm.7 per lato.

Considerata la sporgenza (mm.2/3) della piastrina circolare di appoggio degli espansori per il fissaggio a muro rimane uno spazio utile per le eventuali imperfezioni di verticalità e orizzontalità di mm.5/4 per lato che consente di sistemare bene a piombo ed a livello il serramento.

Dimensioni dei serramenti:

Nel determinare le dimensioni dei serramenti occorre valutare un certo numero di fattori quali: il momento d'inerzia dei profilati, le dimensioni ed il peso del vetro di tamponamento, le dimensioni delle ante mobili, la qualità e la portata degli accessori, il tipo ed il numero dei fissaggi a muro, la posa (altezza, esposizione, zone di vento ecc...). Questi dati sono valutabili sulla base della conoscenza pratica dell'arte dei vari cataloghi e manuali tecnici e delle prescrizioni UNCSAAL. I diagrammi riportati sono stati elaborati sulla base dei momenti d'inerzia frontali dei profilati.

Verniciatura:

Al fine di limitare il processo della corrosione filiforme si devono eseguire alcune importanti regole quali: Sigillare le parti tagliate, evitare ristagni di condensa all'interno del serramento, prestare la massima attenzione alla posa in opera.

I profilati a taglio termico se sottoposti a verniciatura, devono subire un trattamento termico di cottura a temperatura di 180° (-0°+20°) per circa 20-22 minuti.

Durante tutto il processo di verniciatura, i profilati devono essere opportunamente supportati in modo da mantenere la rettilineità iniziale e non subire deformazioni.

Tutti i dati riportati nel presente catalogo sono indicativi e non impegnano la HYDRO BUILDING SYSTEMS S.p.A.

La HYDRO BUILDING SYSTEMS S.p.A. si riserva la facoltà di apportare, in qualsiasi momento, le modifiche che riterrà opportune.

Profilati, accessori e guarnizioni riportati su questo catalogo sono brevettati.

Quanto riportato in questo catalogo è di esclusiva proprietà della HYDRO BUILDING SYSTEMS S.p.A. e a termini di legge, ne è vietata la riproduzione, anche parziale se non esplicitamente autorizzata.

Nella costruzione e nella posa in opera dei serramenti si consiglia di osservare e rispettare le normative, le prescrizioni e le raccomandazioni specifiche, pur non vincolanti, esistenti in Italia.

Per la realizzazione dei serramenti si invita ad attenersi alla tecnologia costruttiva ed applicativa riportata sul catalogo tecnico e di utilizzare le guarnizioni e gli accessori consigliati.

La responsabilità della HYDRO BUILDING SYSTEMS S.p.A. è in ogni caso limitata alla sola sostituzione di quei suoi prodotti che risultassero difettosi all'origine.

Consigli Pratici

-Lavorazione

-Protezione

-Pulizia

-Manutenzione dell'alluminio verniciato e ossidato

1-IMBALLAGGIO: impiegare la giusta protezione, evitando d'espore il profilato protetto direttamente ai raggi solari. In ogni caso il prodotto impiegato per eventuali rimballi dev'essere compatibile con la verniciatura o l'ossidazione ed occorre eseguire le istruzioni del fornitore.

2-LAVORAZIONE: Durante tutte le fasi di lavorazione manovrare i profilati con estrema delicatezza ed accertarsi che l'ambiente di lavoro sia sempre pulito. Usare la massima cura nella movimentazione dei pezzi, evitando il contatto con scorie o residui di limature provenienti da lavorazioni precedenti.

3-ATTREZZATURE: Accertarsi che i macchinari ed utensili siano sempre efficienti ed adatti al compito da svolgere, in particolare le lame e le troncatrici, per il raffreddamento degli utensili, evitare l'utilizzo di prodotti che possano intaccare la colorazione dei profilati e pregiudicarne la qualità.

4-SIGILLATURA: Sigillare accuratamente con prodotti idonei tutti i tagli e /o fari di lavorazione del serramento, bloccando perfettamente ogni zona soggetta ad infiltrazione.

Accertarsi sempre che ci sia un corretto drenaggio all'interno dello scatolato del serramento.

5-ACCESSORI: Utilizzare esclusivamente accessoristica di ottima qualità. La viteria dev'essere in materiale adatto e, possibilmente, isolato. Ricordare sempre che tutto ciò che non è alluminio, ma in contatto con quest'ultimo, può creare problemi di corrosione. Evitare l'uso delle squadrette in ferro non opportunamente trattate.

6-LUBRIFICANTI: Eseguire con particolare attenzione ad apposito olio la lubrificazione dell'accessoristica.

7-POSA IN OPERA: La buona norma richiede sempre d'installare per ultimo il serramento in alluminio, evitando in questo modo possibili inconvenienti dovuti al contatto con sostanze presenti in cantiere che possono danneggiare le superfici verniciate o anodizzate.

Il montaggio del serramento dev'essere eseguito ad opere murarie asciutte.

8-MANUTENZIONE E PULIZIA: Per mantenere il più possibile inalterate nel tempo le superfici anodizzate o verniciate, è necessario che le stesse siano opportunamente pulite con prodotti appositi.

LE CARATTERISTICHE DI TALI PRODOTTI, UNITAMENTE ALLA FREQUENZA DELLE OPERAZIONI DI PULIZIA DA ESEGUIRE SCRUPOLOSAMENTE, SONO DEFINITE NEI PROGETTI UNIMET E12.04.270.0 ED E12.04.277.0

IN OGNI CASO SI RACCOMANDA VIVAMENTE DI:

-Pulire le superfici **quando non sono esposte a fonti di calore diretto**, ad esempio raggi solari.

-Utilizzare per la pulizia una spugna o un panno morbido bagnato con apposito detergente.

-Il detergente dev'essere neutro, non abrasivo, non a base di ammoniaca, non a base di cloro (ad esempio candeggina).

Le parti meccaniche devono essere pulite ed oliate con spray al silicone oppure teflon e controllate anche a livello d'usura.

HYDRO BUILDING SYSTEMS S.p.A fornisce prodotti con finiture garantite dai marchi QUALANOD e QUALICOAT

DESCRIZIONE TECNICA DEL SISTEMA

Profilati estrusi lega: EN AW-6060

Stato di fornitura: T5

Tolleranze dimensionali e spessori: EN 12020/2

Tipo dei profilati:

- Doghe verticali con dimensioni da 60-70-80mm. e loro multipli



Dimensioni base:

- Telai: Da 40mm. + compensatore (totale 50mm.)
Da 46mm. (compreso compensatore)
- BATTENTI
Da 55mm. (compreso compensatore)
- Ante: Profondita' 30 mm.



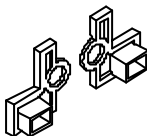

Impiego: E' possibile realizzare persiane (finestre o porte) con oscuramento totale (fisso cieco) nelle seguenti tipologie di apertura.

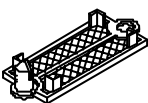
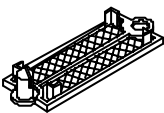
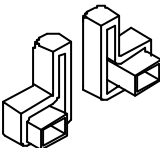
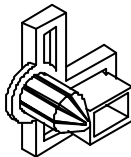

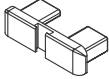
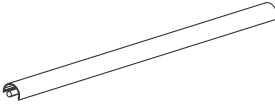
- Finestre - Porte ad 1-2 ante
 - SOLUZIONE PADOVANA
 - SOLUZIONE VICENTINA

ACCESSORI accessories	CODICE code	COLORE colour	DESCRIZIONE description	MATER. mater.	CONFEZ. pack.
	04 A 22	GREZZO millfinish	SQUADRETTA PER TELAIO Pr 27388-60155-27457 corner joint for Pr 27388-60155- 27457	ALLUMINIO aluminium	PEZZI 20 pieces 20
	30 B 80	RAL6005 RAL8017 RAL9005	CERNIERA A PETTINE hinge	ALLUMINIO aluminium	PEZZI 50 pieces 50
	30 C 110	RAL9005	FERMO SUPERIORE PER SPAGNOLETTA PER TELAIO Pr 27388-27457-60155 over block for closing for Pr 27388-27457 60155	ACCIAIO ZINCATO galv. steel	PEZZI 200 pieces 200
	30 C 111	NERO black	FERMO INFERIORE PER SPAGNOLETTA block for marble	ACCIAIO ZINCATO galv. steel	PEZZI 200 pieces 200
	30 C 112	NERO black	FERMO INFERIORE, AD AVVITARE, PER SPAGNOLETTA lower block	ACCIAIO ZINCATO galv. steel	PEZZI 200 pieces 200

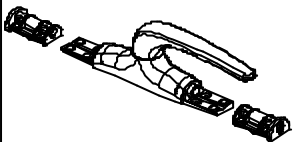
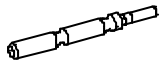
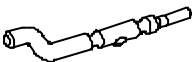

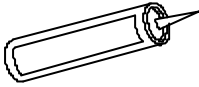

ACCESSORI accessories	CODICE code	COLORE colour	DESCRIZIONE description	MATER. mater.	CONFEZ. pack.
	30 D 100	RAL6005 RAL8017 RAL9005	TAPPO TERMINALE Pr 27384 final plugs for Pr 27384	NYLON nylon	PEZZI 100 pieces 100
	30 D 101	RAL6005 RAL8017 RAL9005	TAPPO CENTRALE Dx-Sx Pr 27385-27393 -60156 central plugs L-R for Pr 27385-27393 -60156	NYLON ALLUMINIO nylon aluminium	PEZZI 50 pieces 50
	30 D 102	RAL6005 RAL8017 RAL9005	TAPPO DOGA 60mm Pr 27381 plugs for Pr 27381	ALLUMINIO aluminium	PEZZI 50 pieces 50
	30 D 103	NERO MARRONE VERDE black brown green	TAPPO DOGA 70mm Pr 27382 plugs for Pr 27382	NYLON nylon	PEZZI 50 pieces 50
	30 D 104	NERO MARRONE VERDE black brown green	TAPPO DOGA 80mm Pr 27383 plug for Pr 27388	NYLON nylon	PEZZI 50 pieces 50
	30 D 106	NERO MARRONE VERDE black brown green	TAPPO PER Pr 27385-27393-60156 SOLUZIONE CON Pr 27390 plug for Pr 27385-27393-60156 for solutions whit Pr 27390	NYLON nylon	COPPIE 50 pairs 50
	30 D 107	NERO MARRONE VERDE black brown green	TAPPO CENTRALE Dx-Sx PER Pr 27385-27393 CON FIOLO central plugs L-R for Pr 27385-27393 whit rung	ACCIAIO ZINCATO galv. steel	PEZZI 200 pieces 200

ACCESSORI accessories	CODICE code	COLORE colour	DESCRIZIONE description	MATER. mater.	CONFEZ. pack.
	4240005	GREZZO millfinish	TAPPO CHIUDI TUBOLARITA' Pr 27459 plugs for Pr 27459	NYLON nylon	PEZZI 50 pieces 50
	62 D 0L	RAL9005 RAL9010	ASTE L 1400mm PER CREMONESE FAP1872 aughtion L 1400mm for cremone FAP1872	ALLUMINIO aluminium	PEZZI 10 pieces 10







ACCESSORI accessories	CODICE code	COLORE colour	DESCRIZIONE description	MATER. mater.	CONFEZ. pack.
	91 E 01	GREZZO millfinish	ESPANSORE CON GRANO M12 L= 20mm expansor with bolt M12 L=20mm.	ZAMA mazak	PEZZI 100 pieces 100
	91 E 02	GREZZO millfinish	ESPANSORE CON GRANO M12 L= 30mm expansor with bolt M12 L=30mm.	ZAMA mazak	PEZZI 100 pieces 100
	FAP1872	RAL9005 RAL9010	CREMONESE MANICO BASSO low handle cremone	ALLUMINIO aluminium	PEZZI 10 pieces 10
	FAP1892AX	GREZZO millfinish	TERMINALE DIRITTO INFERIORE stright terminal	ACCIAIO INOX inox steel	PEZZI 50 pieces 50
	FAP1892BX	GREZZO millfinish	TERMINALE PIEGATO SUPERIORE fold terminal	ACCIAIO INOX inox steel	PEZZI 50 pieces 50
	FAP1893A	RAL9005 RAL9010	INCONTRO SUPERIORE striker	ZAMA mazak	PEZZI 10 pieces 10
	FAP1895	GREZZO millfinish	BUSSOLA PER SOGLIA INFERIORE compass for threshold	OTTONE brass	PEZZI 50 pieces 50

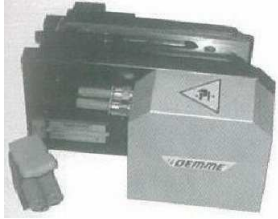



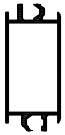
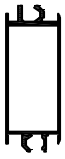
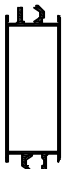

ACCESSORI accessories	CODICE code	COLORE colour	DESCRIZIONE description	MATER. mater.	CONFEZ. pack.
	91 Y 01M	NEUTRO neutral	COLLANTE MONOCOMPONENTE PER METALLI (consigliato per l'unione degli angoli) glue for metal		PEZZI 25 pieces 25
	91 Y 03		ALUGLIT PER PULIZIA SUPERFICI VERNICIATE (FLACONI 250ml.) painting surface cleaner		PEZZI 24 pieces 24
	91 Y 04		ALUGLIT PER PULIZIA SUPERFICI OSSIDATE (FLACONI 250ml.) anodizing surface cleaner		PEZZI 24 pieces 24



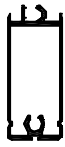

ACCESSORI accessories	CODICE code	COLORE colour	DESCRIZIONE description	MATER. mater.	CONFEZ. pack.
	30 V 00	GREZZO millfinish	VITE M6 TESTA A CROCE PER TASSELLO FISSAGGIO DOGHE screw M6 for dowel fixing	ACCIAIO INOX inox steel	PEZZI 200 pieces 200
	30 V 01	GREZZO millfinish	TASSELLO FISSAGGIO DOGHE dowel for fixing	OTTONE brass	PEZZI 200 pieces 200
	30 V 05	GREZZO millfinish	GRANO M6 x 25 grub screw M6 x 25	ACCIAIO INOX inox steel	PEZZI 200 pieces 200

ACCESSORI accessories	CODICE code	DESCRIZIONE description	BOBINE reels m	SCATOLA box
	90 G 26	<p>GUARNIZIONE PER BATTUTA INTERNA</p> <p>MATERIALE: ELAPRENE material: elaprene COLORE: NERO colour: black</p> <p>gasket for inside rabbet</p>	400	
	90 G 27	<p>GUARNIZIONE PER BATTUTA INTERNA</p> <p>MATERIALE: EPDM material: epdm COLORE: NERO colour: black</p> <p>gasket for inside rabbet</p>	<p>DOPPIA 200</p> <p>double 200</p>	
	90 G 31	<p>GUARNIZIONE DI BATTUTA</p> <p>MATERIALE: EPDM material: epdm COLORE: NERO colour: black</p> <p>gasket for inside rabbet</p>	400	
	90 G 91	<p>GUARNIZIONE DI BATTUTA A BASE RIGIDA</p> <p>MATERIALE: PVC material: pvc COLORE: NERO colour: black</p> <p>gasket for inside rabbet whit hard base</p>	300	
	90 S 65	<p>SPAZZOLINO DI TENUTA PERIMETRALE 4,8x9mm</p> <p>MATERIALE: POLIPROPILENE material: polypropil. COLORE: NERO colour: black</p> <p>shutterpile for perimetral</p>	225	

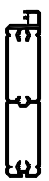
CODICE code	DESCRIZIONE description	CONFEZ. pack.	
40 W 06	PUNZONATRICE PER SQUADRETTA Cod. 04 A 22 pneumatic punching machine for Cod. 04 A 22	PEZZI 1 pieces 1	

SEZIONE	CODICE Jx cm ⁴ Wx cm ³	PESO kg/m.	SUP. IN VISTA mm.	PERIM. EST. mm.	PERIM. TOT. mm.	DESCRIZIONE
	Pr 01060	0,383	30	146	146	PROFILATO mm. 45x15x2
	Pr 01081	0,464	40	176	176	PROFILATO mm. 50x20x2
	Pr 27381	0,864	120	268	420	PROFILATO DOGA mm. 60
	Pr 27382	0,940	140	288	460	PROFILATO DOGA mm. 70
	Pr 27383	1,015	160	308	500	PROFILATO DOGA mm. 80
	Pr 27384	0,343	42	138	138	PROFILATO TERMINALE
	Pr 27385	0,548	62	166	205	PROFILATO TERMINALE DOGA PER NODO LATERALE E CENTRALE PIANO
	Pr 27388	0,618	74	146	272	PROFILATO TELAIO

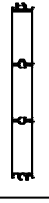
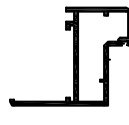
SEZIONE	CODICE Jx cm ⁴ Wx cm ³	PESO kg/m.	SUP. IN VISTA mm.	PERIM. EST. mm.	PERIM. TOT. mm.	DESCRIZIONE
	Pr 27390	0,567	42	98	98	PROFILATO CHIUDI TUBOLARITA'
	Pr 27391	0,497	90	199	199	PROFILATO TELAIO (SOLUZIONE CON BANDELLE)
	Pr 27392	0,537	85	153	223	PROFILATO TELAIO (SOLUZIONE CON BANDELLE)
	Pr 27393	0,556	62	169	208	PROFILATO TERMINALE DOGA NODO CENT. PIANO
	Pr 27457	1,015	135	254	420	PROFILATO TELAIO
	Pr 27458	0,972	164	249	466	PROFILATO DOGA DI PARTENZA DA mm. 68,5
	Pr 27459	0,292	42	121	121	PROFILATO CHIUDI TUBOLARITA'
	Pr 27460	2,014	348	382	902	PROFILATO DOGA DI PARTENZA CON BATTUTA DA mm. 147

SEZIONE	CODICE Jx cm ⁴ Wx cm ³	PESO kg/m.	SUP. IN VISTA mm.	PERIM. EST. mm.	PERIM. TOT. mm.	DESCRIZIONE
	Pr 60152	2,017	367	450	941	PROFILATO DOGA DI PARTENZA DA mm. 168,5
	Pr 60153	1,904	320	469	894	PROFILATO DOGA INTERMEDIA DA mm. 160
	Pr 60154	2,884	480	630	1289	PROFILATO DOGA INTERMEDIA DA mm. 240
	Pr 60155	1,040	140	274	436	PROFILATO TELAIO CON BATTUTA A MURO
	Pr 60156	0,618	71	201	241	PROFILATO TERMINALE CON BATTUTA

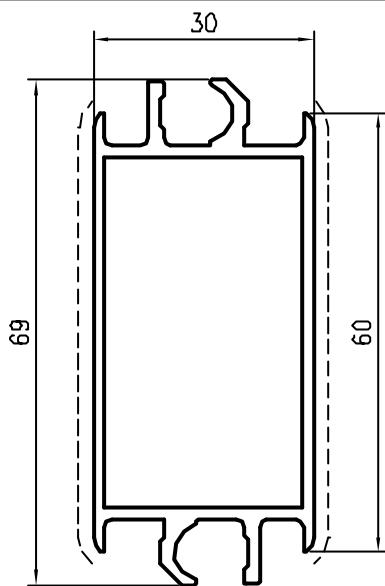

Pr 27381 kg/m. 0,864
sup.in vista mm. 120

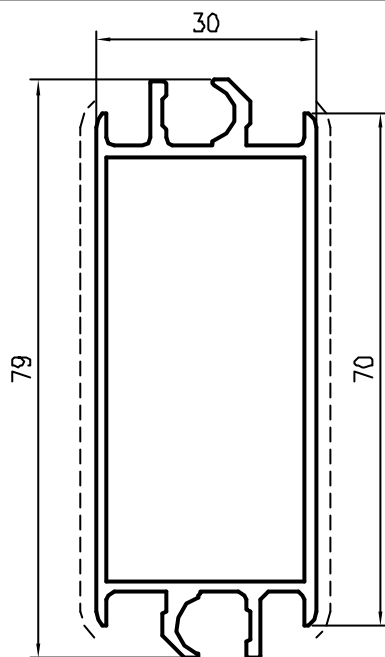

Pr 27382 kg/m. 0,940
sup.in vista mm. 140

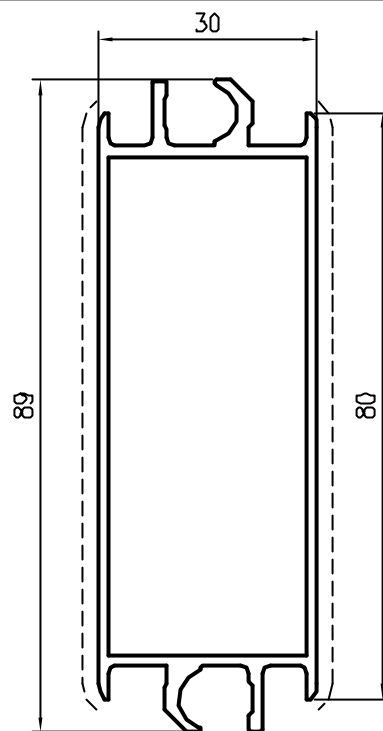

Pr 27383 kg/m. 1,015
sup.in vista mm. 160

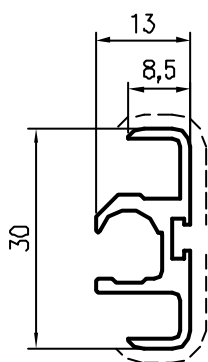

Pr 27384 kg/m. 0,343
sup.in vista mm. 42

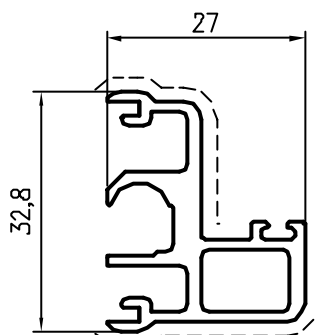

Pr 60156 kg/m. 0,618
sup.in vista mm. 71

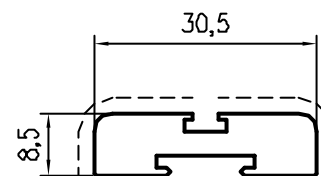

Pr 27390 kg/m. 0,567
sup.in vista mm. 42

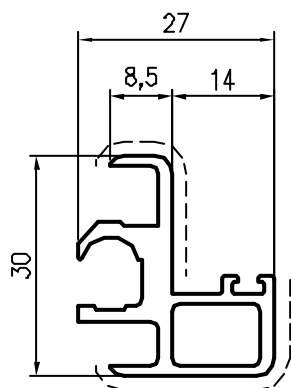

Pr 27385 kg/m. 0,548
sup.in vista mm. 62

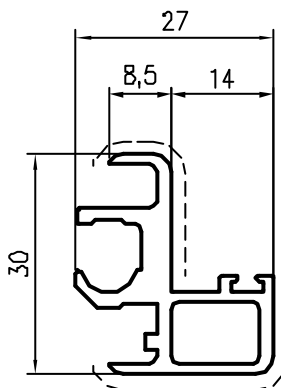

Pr 27393 kg/m. 0,556
sup.in vista mm. 62

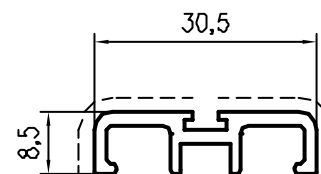

Pr 27459 kg/m. 0,292
sup.in vista mm. 42

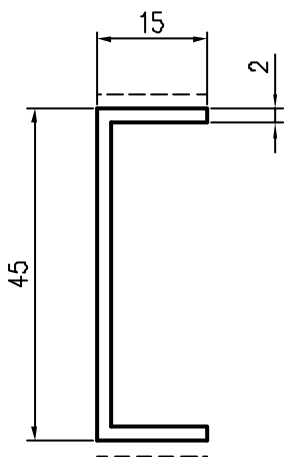

Pr 01060 kg/m. 0,383
sup.in vista mm. 30

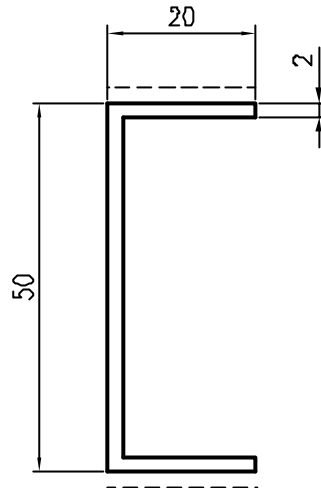

Pr 01081 kg/m. 0,464
sup.in vista mm. 40

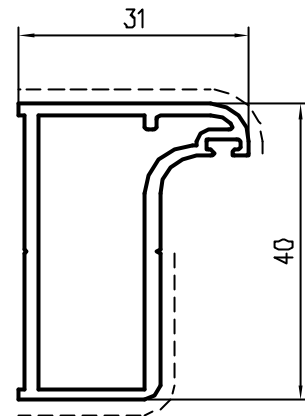

Pr 27388 kg/m. 0,618
sup.in vista mm. 74

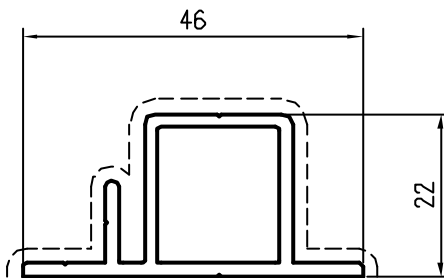

Pr 27392 kg/m. 0,537
sup.in vista mm. 85

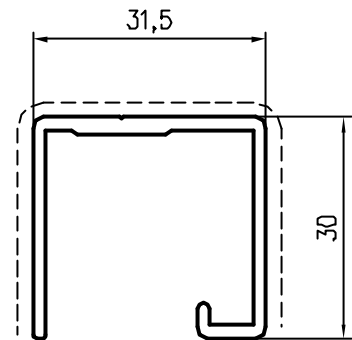

Pr 27391 kg/m. 0,497
sup.in vista mm. 90

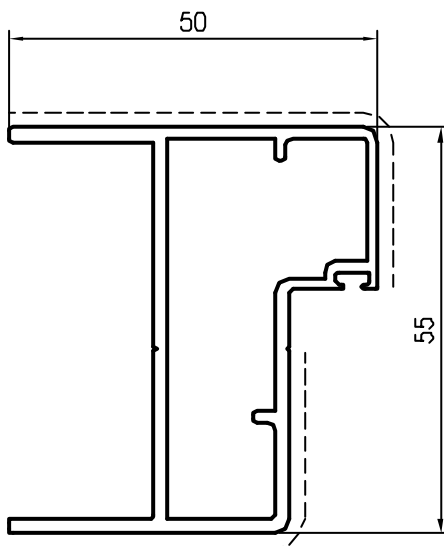

Pr 27457 kg/m. 1,015
sup.in vista mm. 135

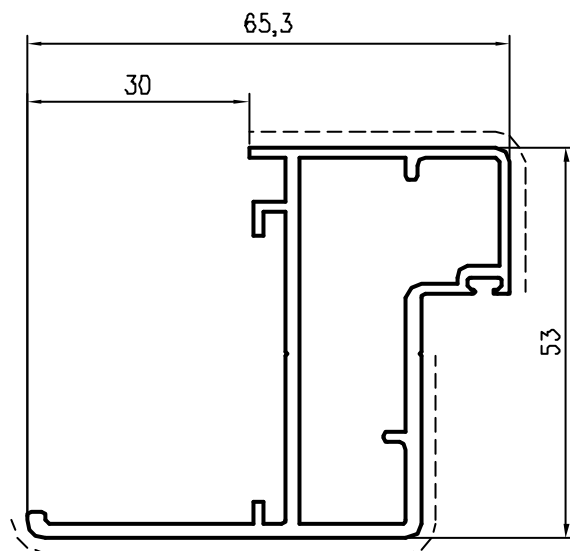

Pr 60155 kg/m. 1,040
sup.in vista mm. 140

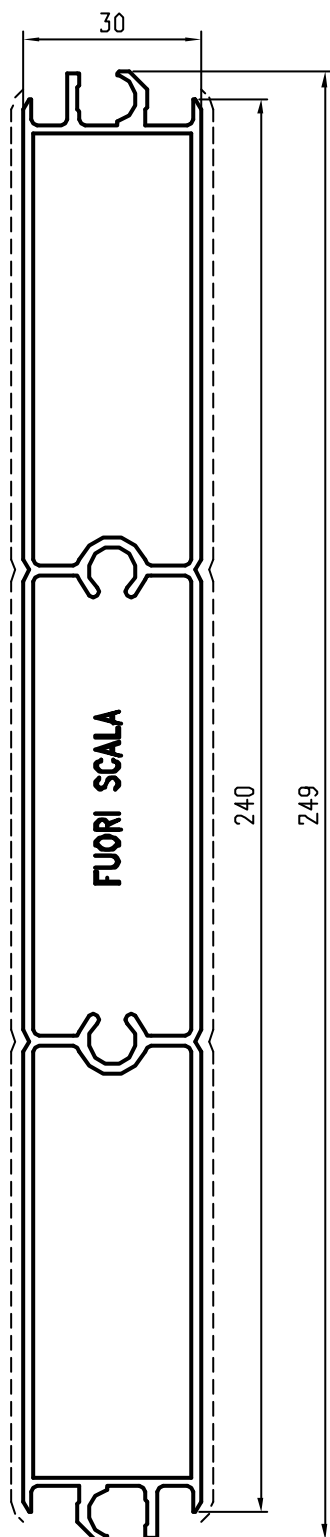

Pr 60154 kg/m. 2,884
sup.in vista mm. 480

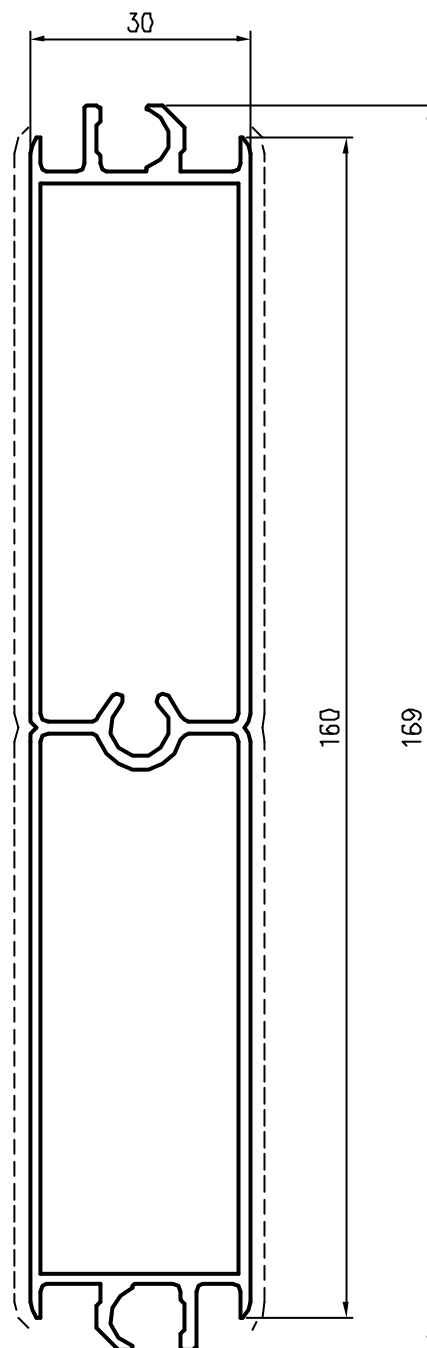

Pr 60153 kg/m. 1,904
sup.in vista mm. 320

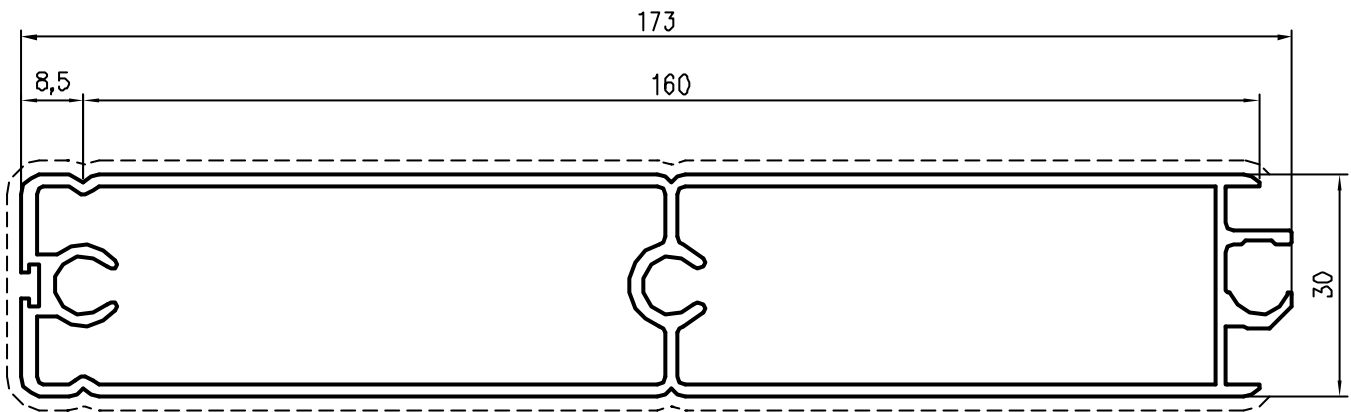

Pr 60152 kg/m. 2,017
sup.in vista mm. 367

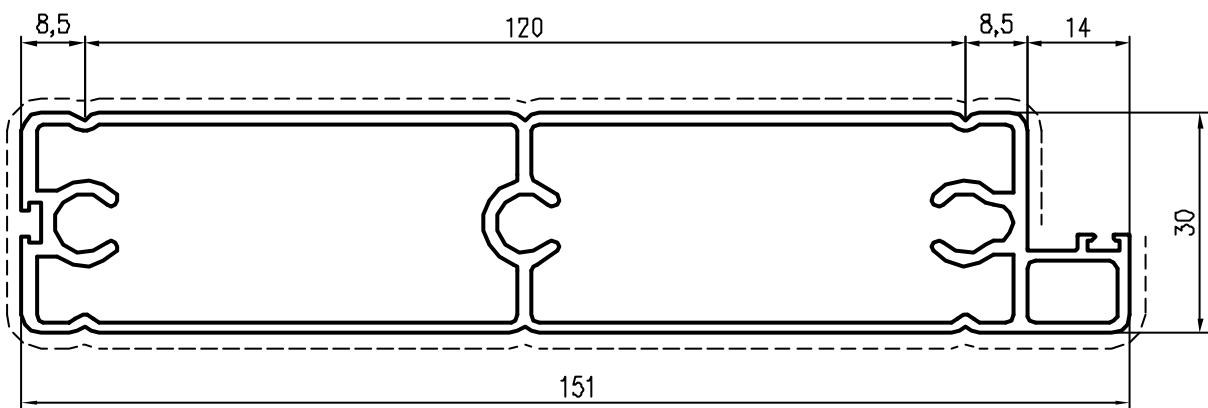

Pr 27460 kg/m. 2,014
sup.in vista mm. 348

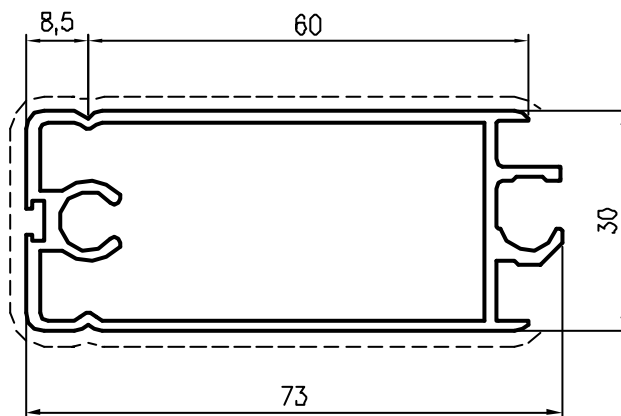

Pr 27458 kg/m. 0,972
sup.in vista mm. 164

PROSPETTO ESTERNO

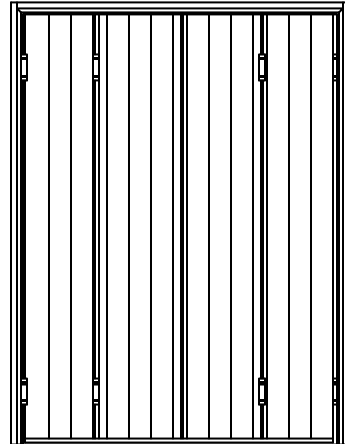

PROFILATI

Nr. Pezzi	Pr	Descrizione	Taglio
1Dx=15x	27388	Montante telaio	H
1	27388	Traverse telaio	L-14
2	01060	Montante compensatore	H
* 10	27381	Montante telo anta	H-50
2	27458	Montante laterale anta	H-50
5	27385	Montante battuta anta	H-50
1	27393	Montante battuta anta	H-50
4	27459	Profilato chiudi tubolarità anta laterale	L/4 - 44,75
4	27459	Profilato chiudi tubolarità anta centrale	L/4 - 49,25

* VARIABILE

ACCESSORI

Nr. Pezzi	Codici	Descrizione
2	04 A 22	Squadretta
* B	30 B 80	Cerniera
1	30 C 110	Fermo superiore per spagnoletta
1	30 C 111	Fermo inferiore a marmo
6 Copple	30 D 106	Tappo terminale Pr 27385 e 27393
2 Copple	4240005	Tappo terminale Pr 27459 in partenza
6	91 E 01	Espansore
32	30 V 01	Tassello fissaggio daghe
32	30 V 00	Vite per tassello

* VARIABILE

GUARNIZIONI

Codici	Descrizione	Taglio
90 G 31	Guarnizione di battuta	5 H + 1L
90 S 65	Spazzolino di tenuta perimetrale	2 H + 2L

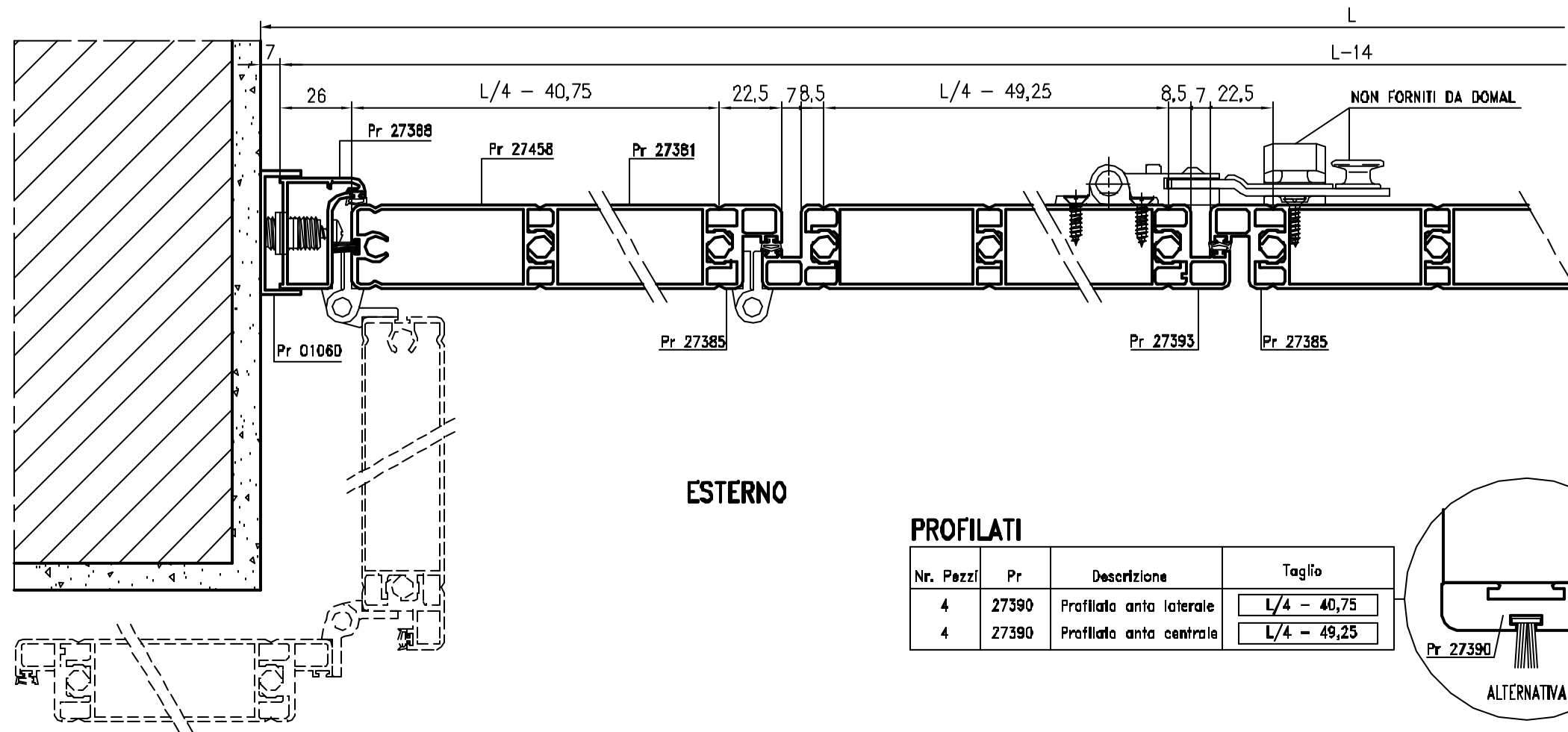

ESTERNO

PROFILATI

Nr. Pezzi	Pr	Descrizione	Taglio
4	27390	Profilato anta laterale	L/4 - 40,75
4	27390	Profilato anta centrale	L/4 - 49,25

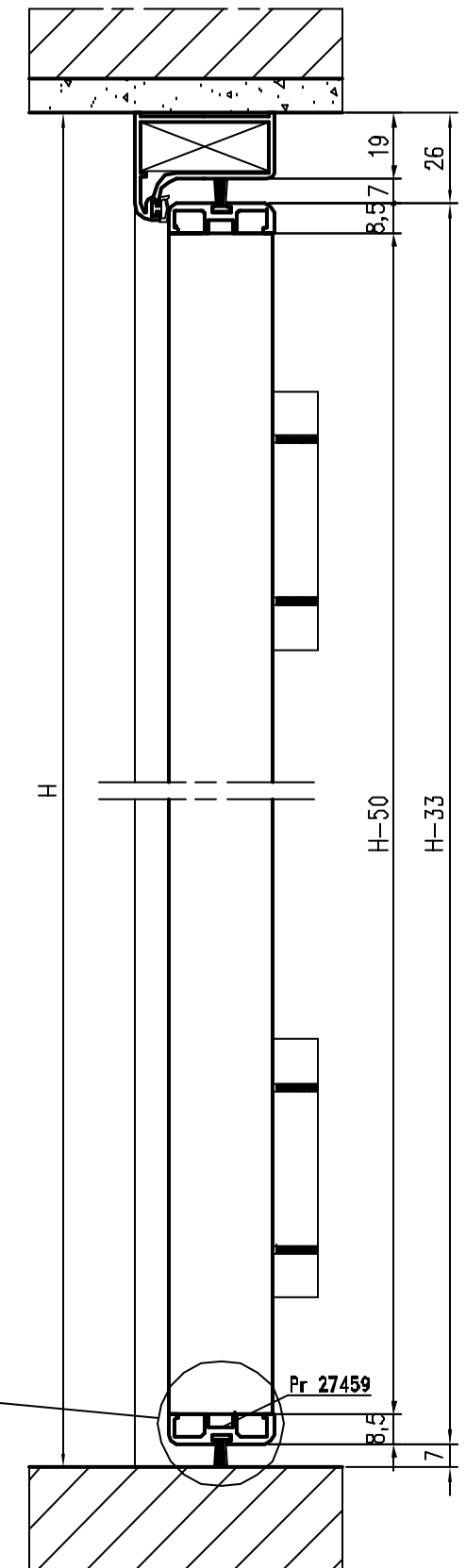
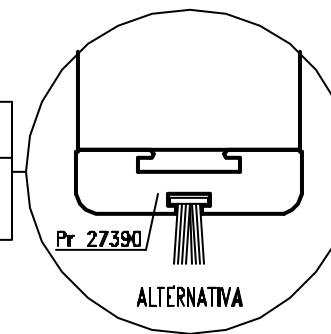

PROSPETTO ESTERNO

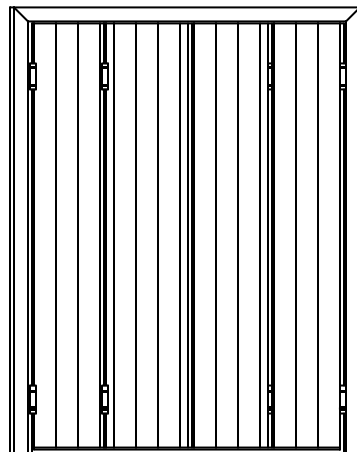

PROFILATI

Nr. Pezzi	Pr	Descrizione	Taglio
1Dx-15x	27457	Montante telaio	H
1	27457	Traverso telaio	L-14
2	01081	Montante compensatore	H
* 10	27381	Montante telo anta	H-69
2	27458	Montante laterale anta	H-69
5	27385	Montante battuta anta	H-69
1	27393	Montante battuta anta	H-69
4	27459	Profilato chiudi tubolarità anta laterale	L/4 - 54,25
4	27459	Profilato chiudi tubolarità anta centrale	L/4 - 58,75

* VARIABILE

ACCESSORI

Nr. Pezzi	Codici	Descrizione
2	04 A 22	Squadretta
* 8	30 B 80	Cerniera
1	30 C 110	Fermo superiore per spagnoletta
1	30 C 111	Fermo inferiore a marmo
6 Coppie	30 D 106	Tappo terminale Pr 27385 e 27393
2 Coppie	4240005	Tappo terminale Pr 27459 in partenza
6	91 E 02	Espansore
32	30 V D1	Tassello fissaggio doghe
32	30 V D0	Vite per tassello

* VARIABILE

GUARNIZIONI

Codici	Descrizione	Taglio
90 G 31	Guarnizione di battuta	5 H + 1L
90 S 65	Spazzolino di tenuta perimetrale	2 H + 2L

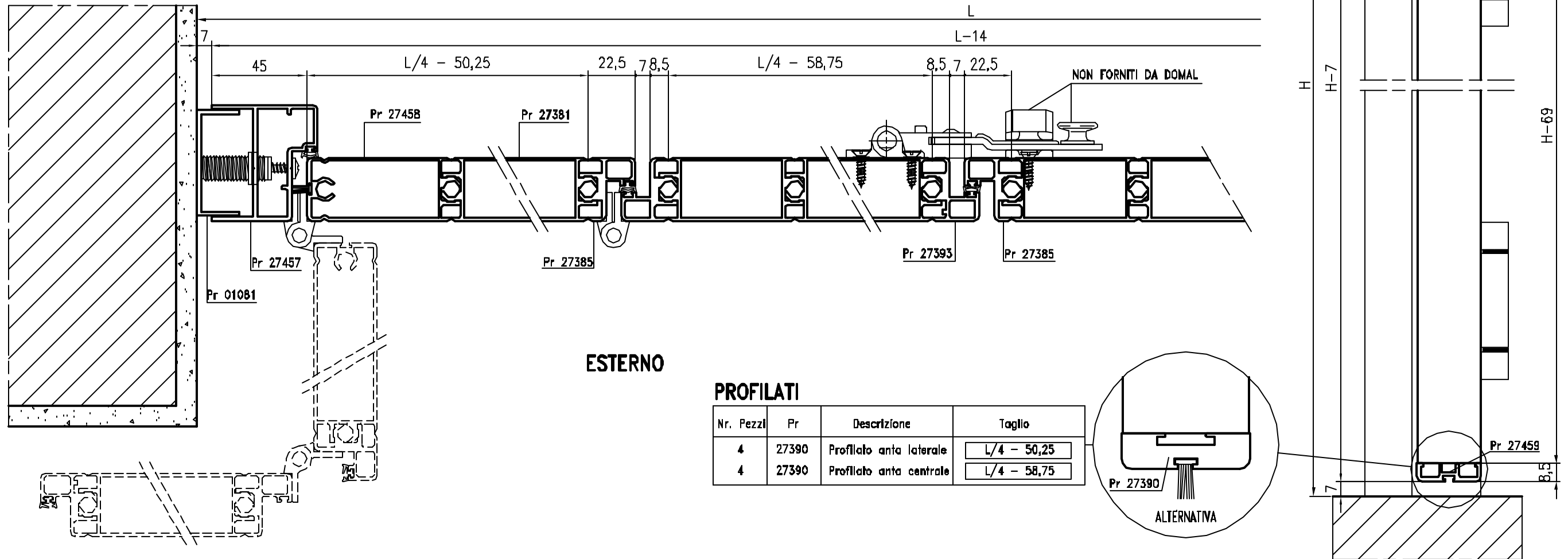

ESTERNO

PROFILATI

Nr. Pezzi	Pr	Descrizione	Taglio
4	27390	Profilato anta laterale	L/4 - 50,25
4	27390	Profilato anta centrale	L/4 - 58,75

PROSPETTO ESTERNO

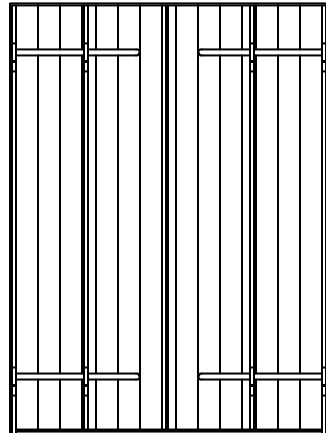

PROFILATI

Nr. Pezzi	Pr	Descrizione	Taglio
* 10	27381	Montante tela anta	H-31
2	27458	Montante laterale anta	H-31
5	27385	Montante battuta anta	H-31
1	27393	Montante battuta anta	H-31
4	27459	Profilato chiudi tubolarità anta laterale	L/4 - 31,75
4	27459	Profilato chiudi tubolarità anta centrale	L/4 - 36,25

* VARIABILE

ACCESSORI

Nr. Pezzi	Codici	Descrizione
1	30 C 111	Fermo inferiore a marmo
1	30 C 112	Fermo superiore per spagnoletta
6 Coppie	30 D 106	Tappo terminale Pr 27385 e 27393
2 Coppie	4240005	Tappo terminale solo per Pr 27459 in partenza
32	30 V 01	Tassello fissaggio deghe
32	30 V 00	Vite per tassello

* VARIABILE

GUARNIZIONI

Codici	Descrizione	Taglio
90 G 31	Guarnizione di battuta	3 H + 1L
90 S 65	Spazzolino di tenuta perimetrale	2 H + 2L

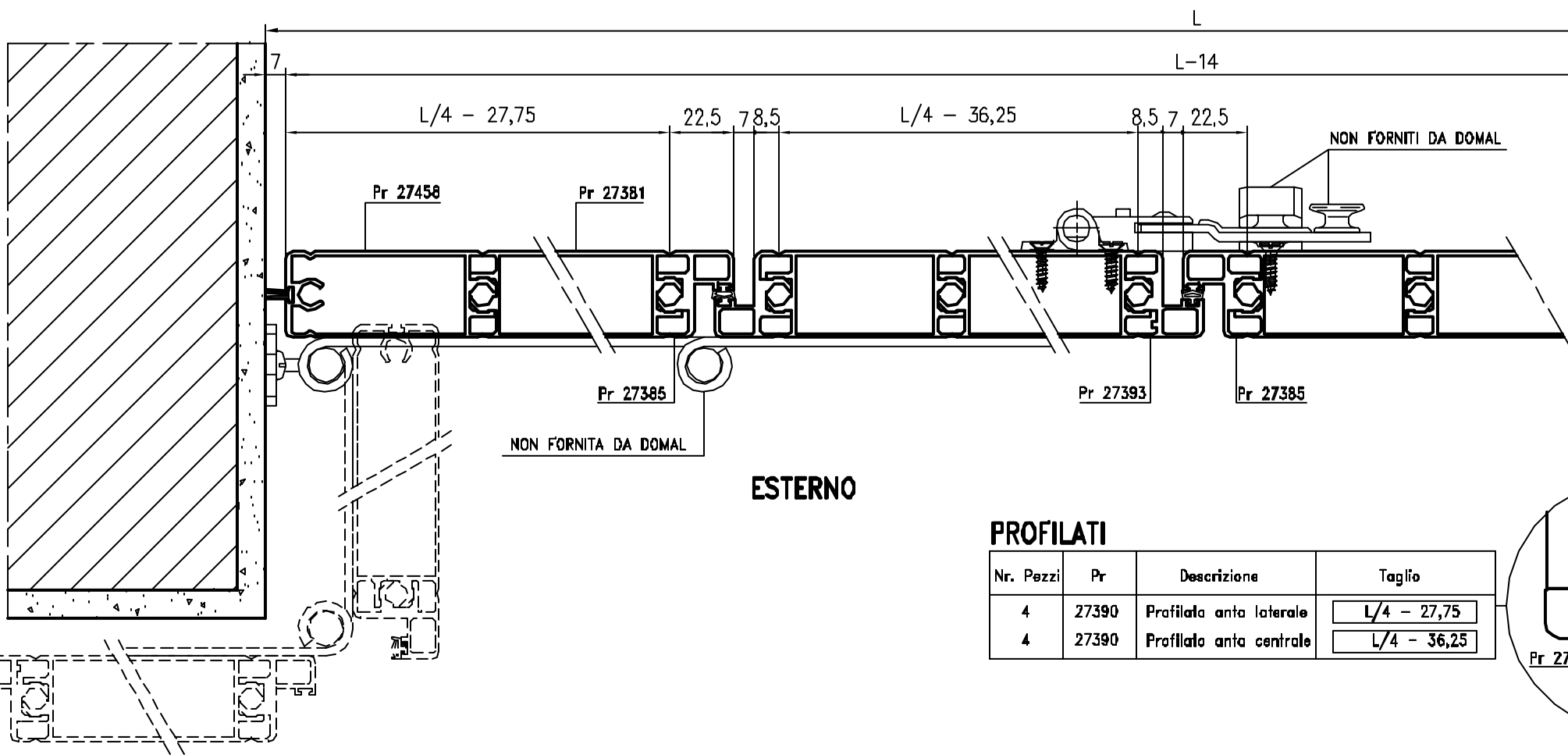

PROFILATI

Nr. Pezzi	Pr	Descrizione	Taglio
4	27390	Profilato anta laterale	L/4 - 27,75
4	27390	Profilato anta centrale	L/4 - 36,25

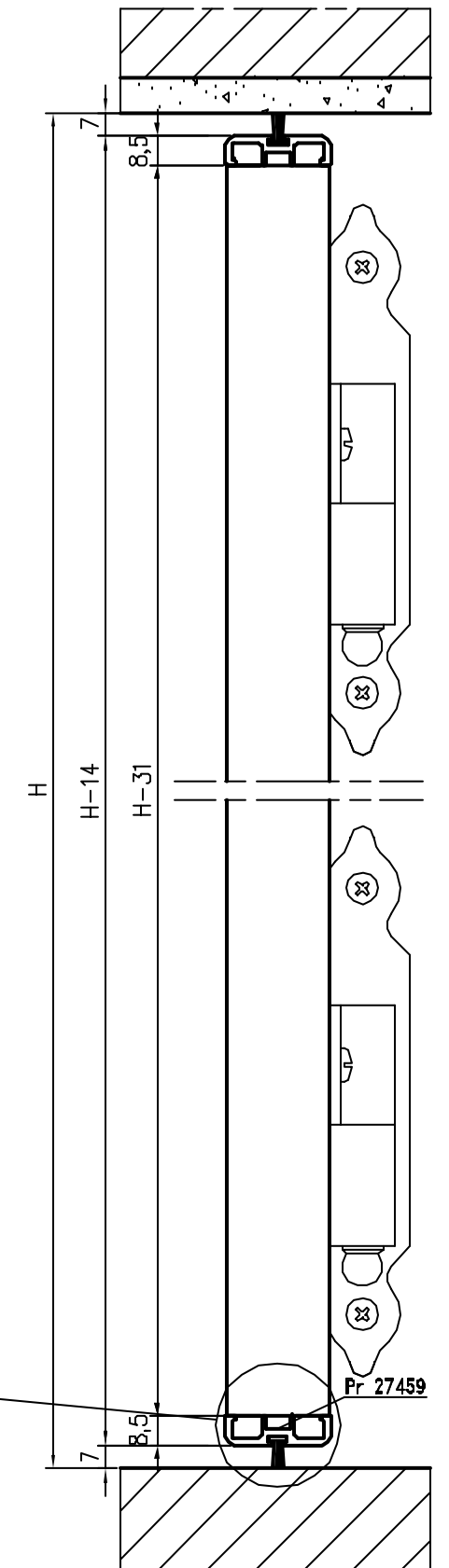
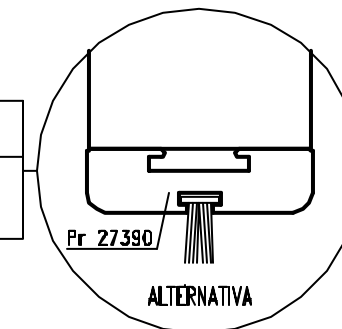

PROSPETTO ESTERNO

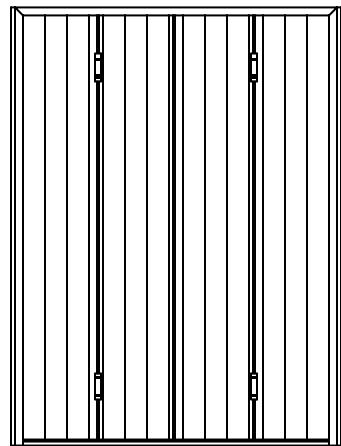

PROFILATI

Nr. Pezzi	Pr	Descrizione	Taglio
10x-15x	27388	Montante telaio	H-7
1	27388	Traverso telaio	L-14
2	01060	Montante compensatore	H
* 10	27381	Montante telo anta	H-35
2	27458	Montante laterale anta	H-35
5	27385	Montante battuta anta	H-35
1	27393	Montante battuta anta	H-35

* VARIABILE

ACCESSORI

Nr. Pezzi	Codici	Descrizione
2	04 A 22	Squadretta
* 8	30 B 80	Cerniera
2 Coppie	30 D 100	Tappo terminale Pr 27458
* 6 Coppie	30 D 101	Tappo terminale Pr 27385 - 27393
* 24 Pezzi	30 D 102	Tappo doge Pr 27381 - 27458
1 Coppie	30 D 107	Tappo terminale Pr 27393 (con piolo)
6	91 E 01	Espansore
2	FAP1872	Cremonese manico basso
2	FAP1892AX	Terminale inox diritto inferiore
2	FAP1892BX	Terminale inox piegato superiore
2	FAP1893A	Incontro in zama superiore
2	FAP1895	Bussola per soglia
32	30 V 01	Tassello fissaggio doghe
32	30 V 00	Vite per tassello

* VARIABILE

GUARNIZIONI

Codici	Descrizione	Taglio
90 G 31	Guarnizione di battuta	5 H + 1L
90 S 65	Spazzolino di tenuta perimetrale	2 H + 2L

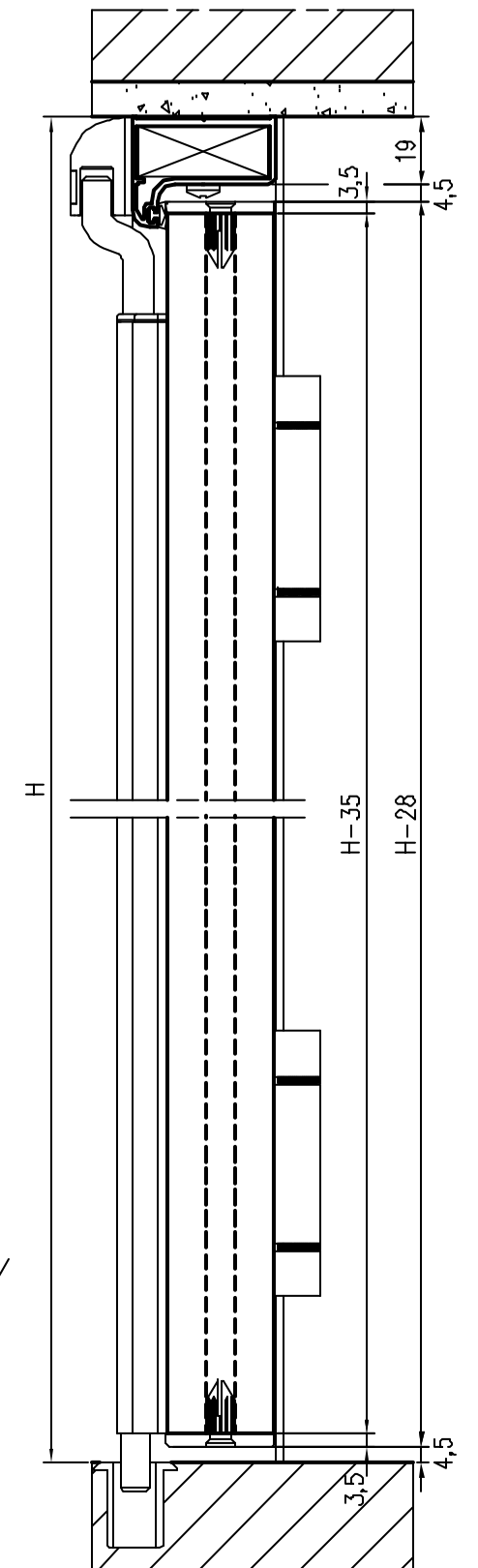
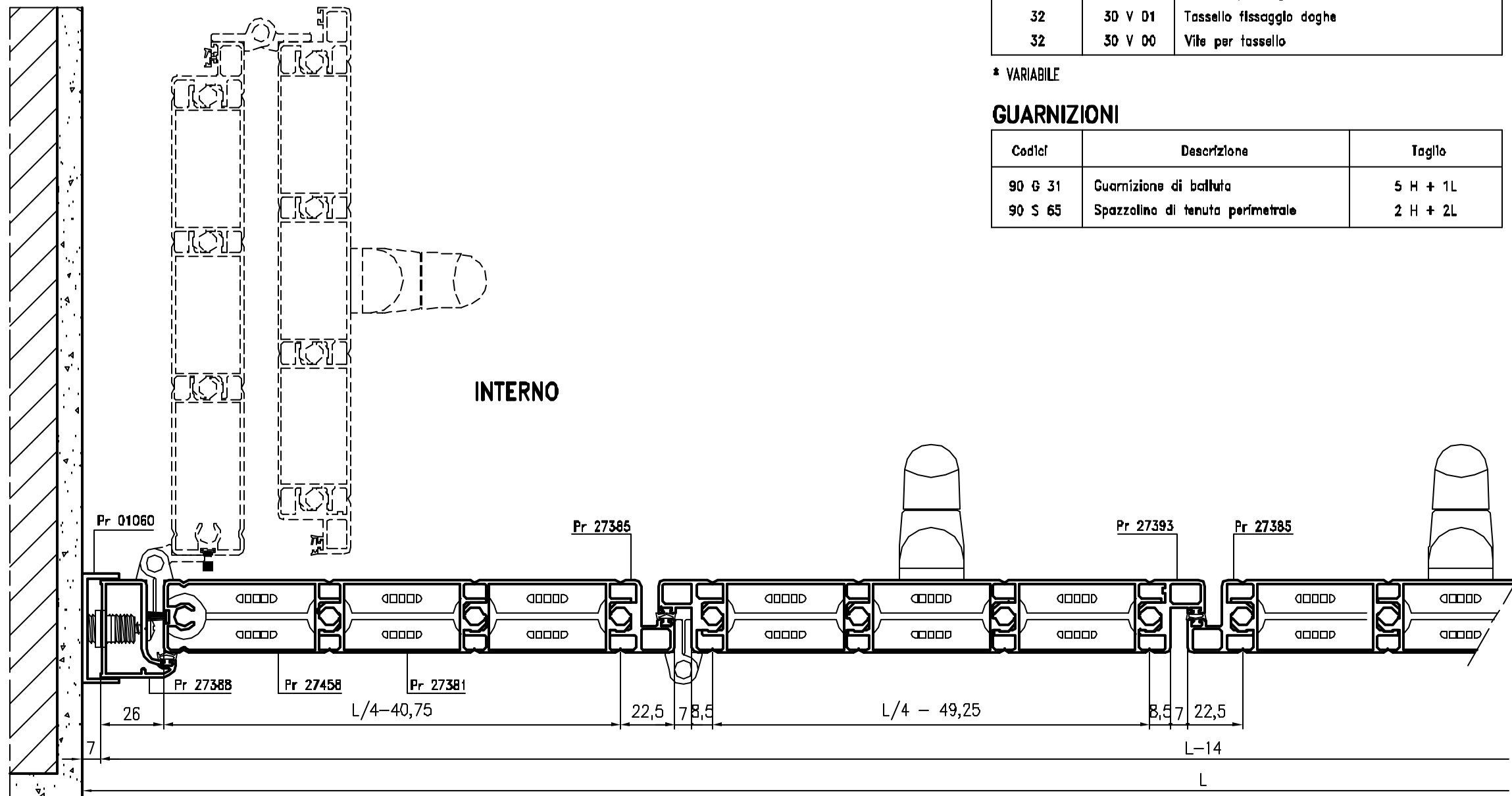

PROSPETTO ESTERNO

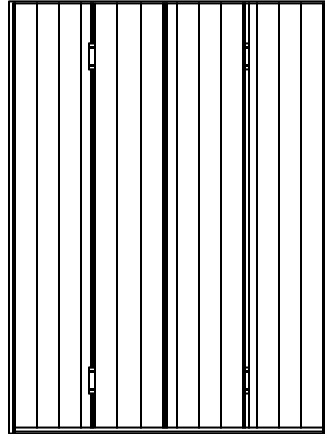

PROFILATI

Nr. Pezzi	Pr	Descrizione	Taglio
* 10	27381	Montante telo anta	H-31
2	27458	Montante laterale anta	H-31
5	27385	Montante battuta anta	H-31
1	27393	Montante battuta anta	H-31
4	27459	Profilato chiudi tubolarità anta laterale	L/4 - 31,75
4	27459	Profilato chiudi tubolarità anta centrale	L/4 - 36,25

* VARIABILE

ACCESSORI

Nr. Pezzi	Codici	Descrizione
* 4	30 B 80	Cerniera
1	30 C 111	Fermo inferiore a marmo
1	30 C 112	Fermo superiore per spagnoletta
6 Copple	30 D 106	Tappo terminale Pr 27385 e 27393
2 Copple	4240005	Tappe terminale Pr 27459 in partenza
2	FAP1872	Cremonese manico basso
2	FAP1892AX	Terminale inox dritto inferiore
2	FAP1892BX	Terminale inox piegato superiore
2	FAP1893A	Incontro in zama superiore
2	FAP1895	Bussola per soglia
32	30 V D1	Tassello fissaggio doghe
32	30 V D0	Vite per tassello

* VARIABILE

GUARNIZIONI

Codici	Descrizione	Taglio
90 G 31	Guarnizione di battuta	3 H + 1L
90 S 65	Spazzolino di tenuta perimetrale	2 H + 2L

PROFILATI

Nr. Pezzi	Pr	Descrizione	Taglio
4	27390	Profilato anta laterale	L/4 - 27,75
4	27390	Profilato anta centrale	L/4 - 36,25

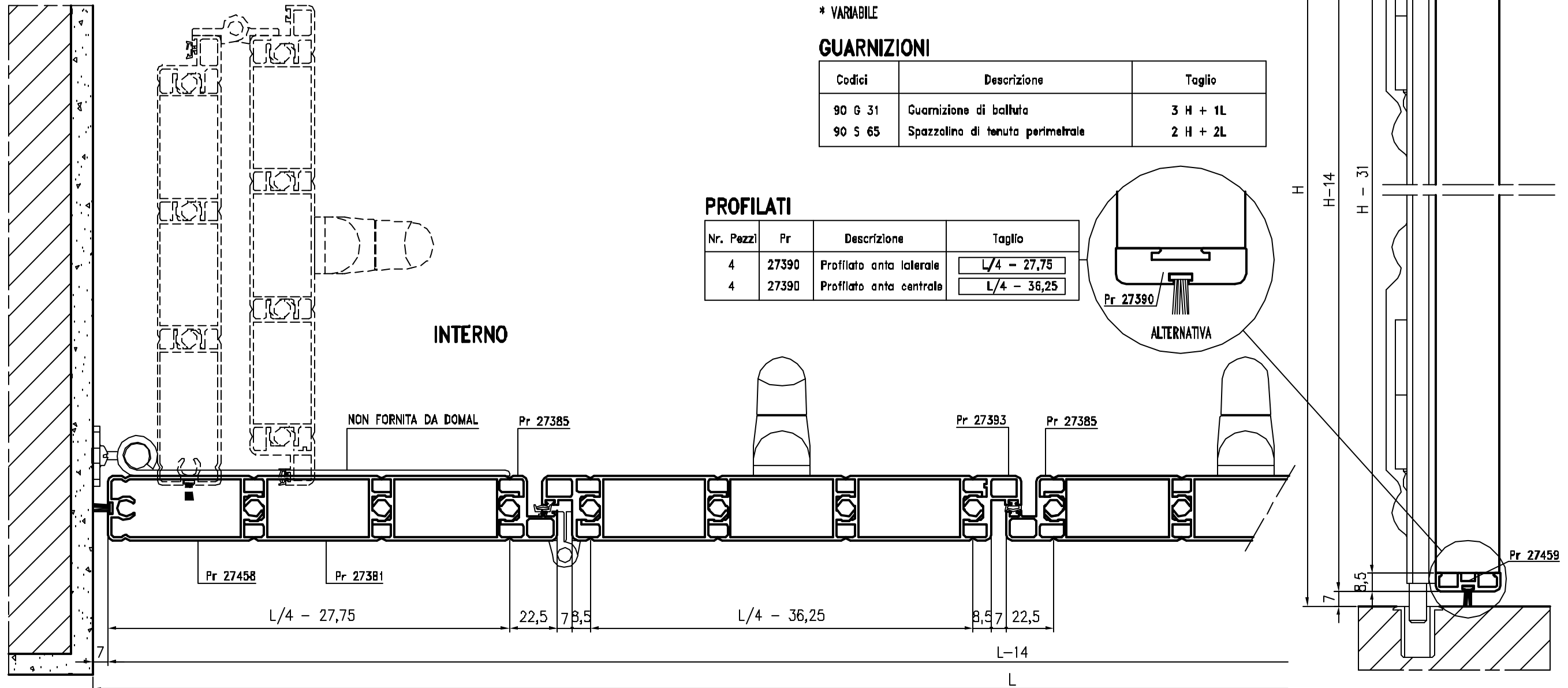
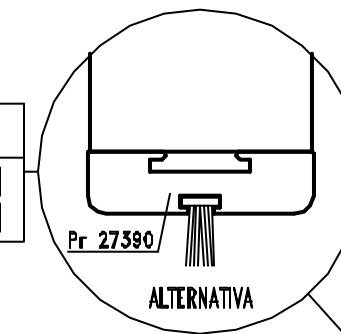

PROSPETTO ESTERNO

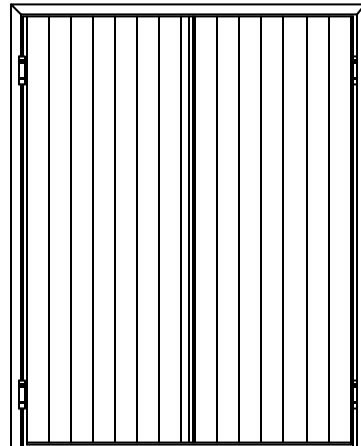

PROFILATI

Nr. Pezzi	Pr	Descrizione	Taglio
1Dx-1Sx	60115	Montante telaio	H
1	60115	Traverso telaio	L
* 12	27381	Montante tela anta	H-67,3
2	27458	Montante laterale anta	H-67,3
2	27393	Montante battuta anta	H-67,3
4	27459	Profilato chiodi tubolarità anta	L/2-83,3

* VARIABILE

ACCESSORI

Nr. Pezzi	Codici	Descrizione
2	04 A 22	Squadrella
* 4	30 B 80	Cerniera
1	30 C 110	Fermo superiore per spagnoletta
1	30 C 111	Fermo inferiore a marmo
2 Coppie	30 D 106	Tappo terminale Pr 27393
2 Coppie	4240005	Tappo terminale Pr 27459 in partenza
8	91 E 01	Espansore
32	30 V 01	Tassello fissaggio doghe
32	30 V 00	Vite per tassello

* VARIABILE

GUARNIZIONI

Codici	Descrizione	Taglio
90 G 31	Guarnizione di battuta	3 H + 1L
90 S 65	Spazzolino di tenuta perimetrale	2 H + 2L

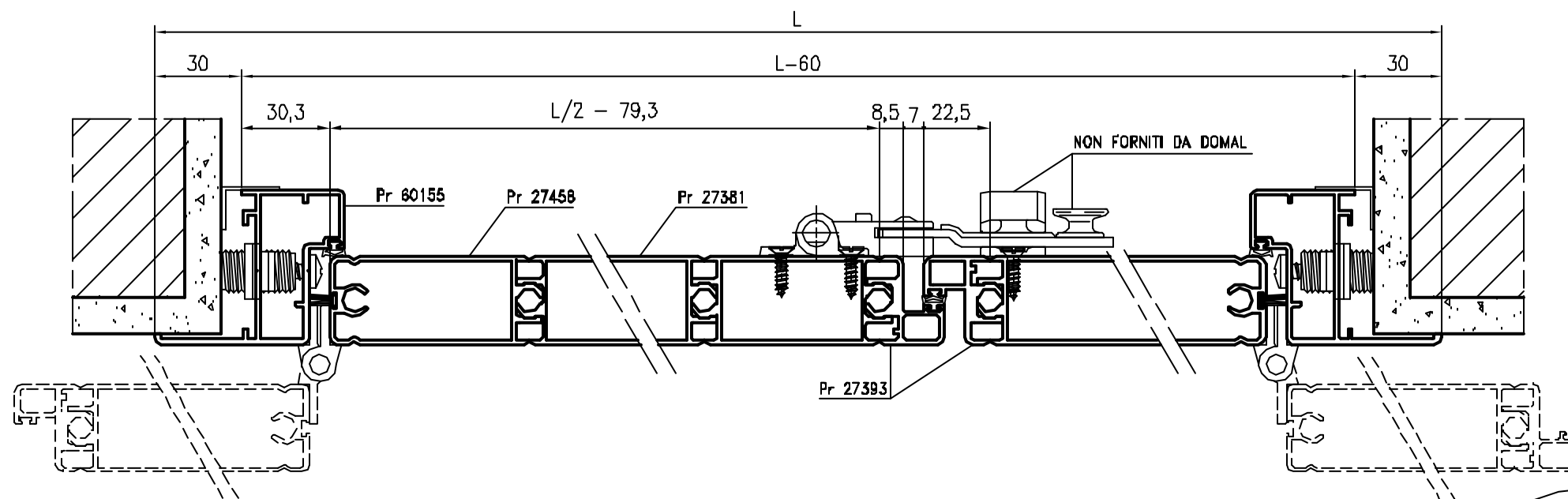

ESTERNO

PROFILATI

Nr. Pezzi	Pr	Descrizione	Taglio
4	27390	Profilato anta	L/2-79,3

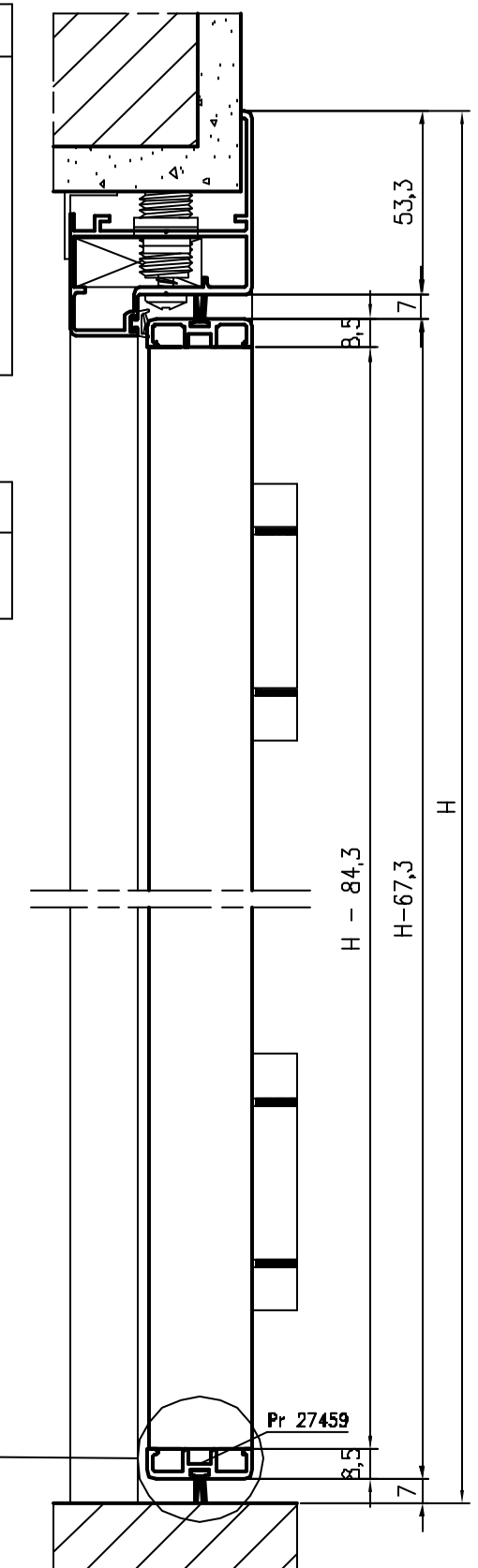
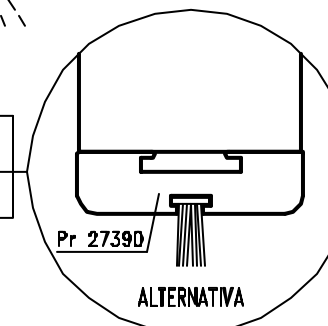

PROSPETTO ESTERNO

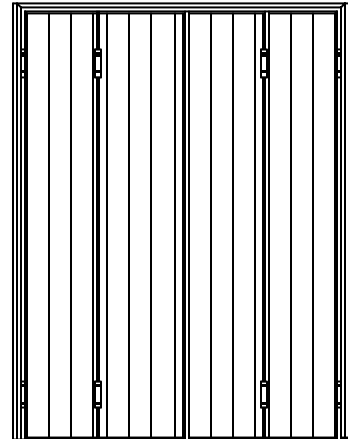

PROFILATI

Nr. Pezzi	Pr	Descrizione	Taglio
1Dx-1Sx	27388	Montante telaio	H
1	27388	Traverso telaio	L-14
2	01060	Montante compensatore	H
* 12	27381	Montante telo anta	H-50
2	27384	Montante laterale anta	H-33
5	27385	Montante battuta anta	H-50
1	27393	Montante battuta anta	H-50
2Dx - 2Sx	27459	Profilato chiudi tubolarità anta laterale	L/4 - 40,75
4	27459	Profilato chiudi tubolarità anta centrale	L/4 - 49,25

* VARIABILE

ACCESSORI

Nr. Pezzi	Codici	Descrizione
2	04 A 22	Squadretta
* 8	30 B 80	Cerniera
1	30 C 110	Fermo superiore per spagnoletta
1	30 C 111	Fermo inferiore a marmo
6 Coppie	30 D 106	Tappo terminale Pr 27385 e 27393
6	91 E 01	Espansore
32	30 V 01	Tassello fissaggio doghe
32	30 V 00	Vite per tassello

* VARIABILE

GUARNIZIONI

Codici	Descrizione	Taglio
90 G 31	Guarnizione di battuta	5 H + 1L
90 S 65	Spazzolino di tenuta perimetrale	2 H + 2L

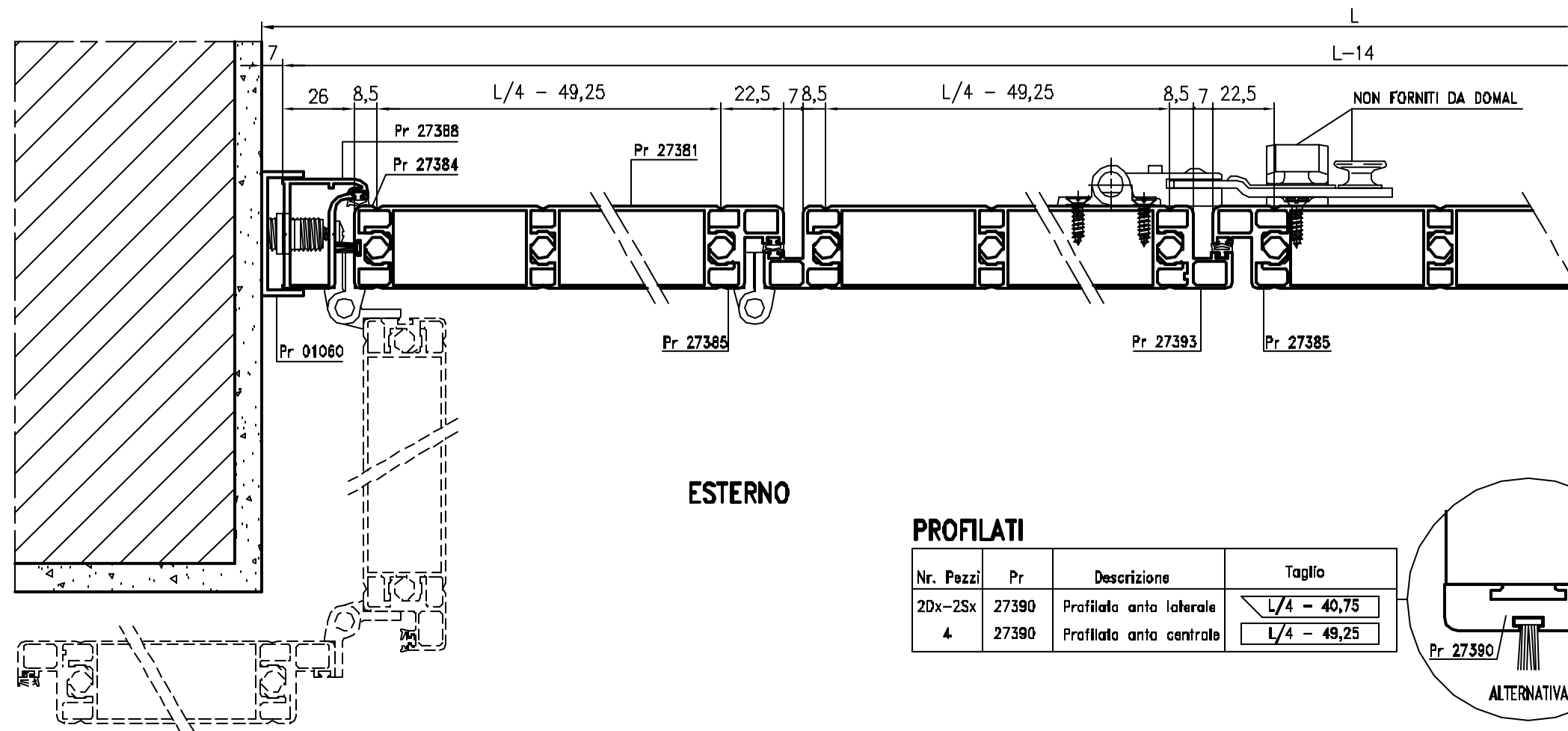

PROFILATI

Nr. Pezzi	Pr	Descrizione	Taglio
2Dx-2Sx	27390	Profilato anta laterale	L/4 - 40,75
4	27390	Profilato anta centrale	L/4 - 49,25

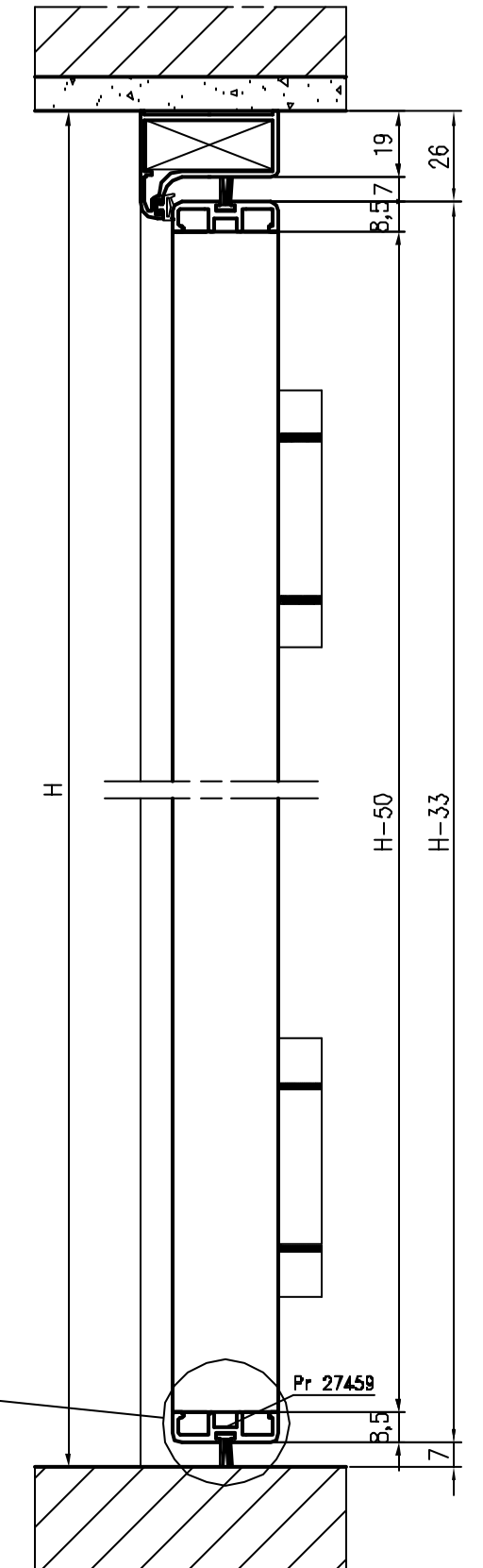
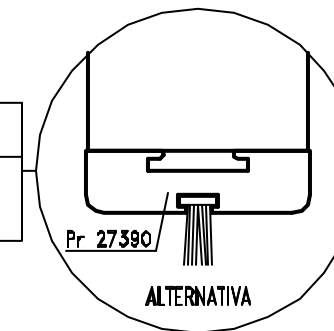

INDICAZIONE PER CERNIERE Cod. 30 B 80

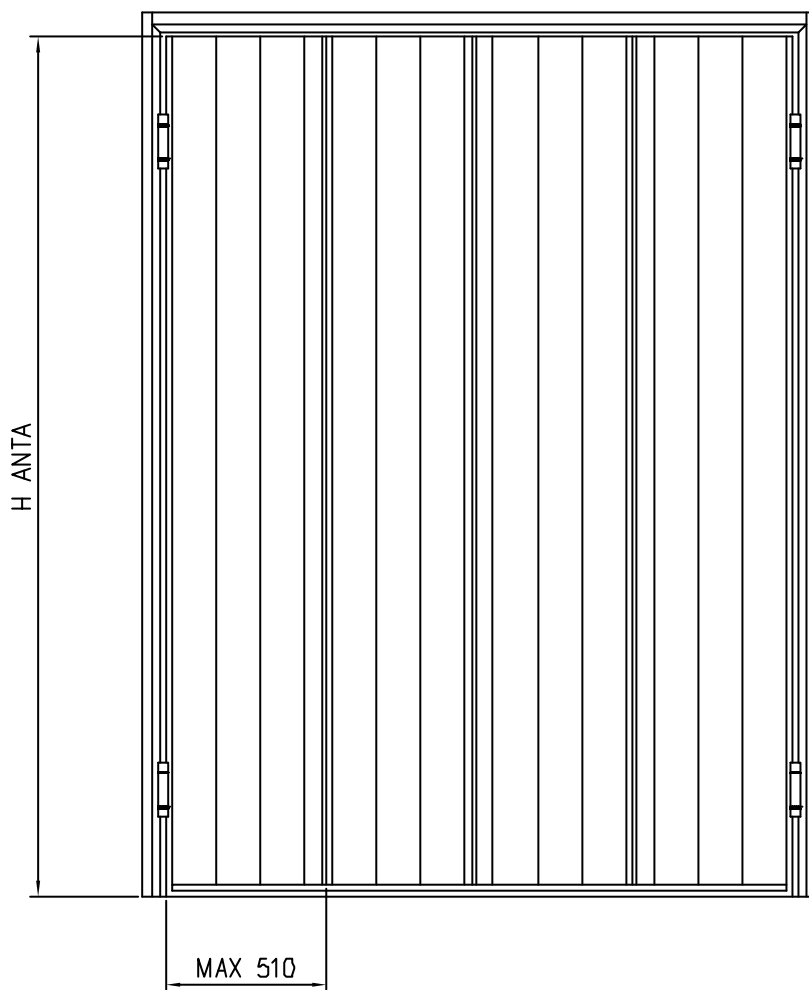

H ANTA mm.	Nr. CERNIERE
FINO A 1300	2
DA 1301 A 2300	3
DA 2301 A 3000	4

DIMENSIONE MAX TELO CONSIGLIATA 510 mm

LAVORAZIONE PER VENTILAZIONE CON PANTOGRAFO

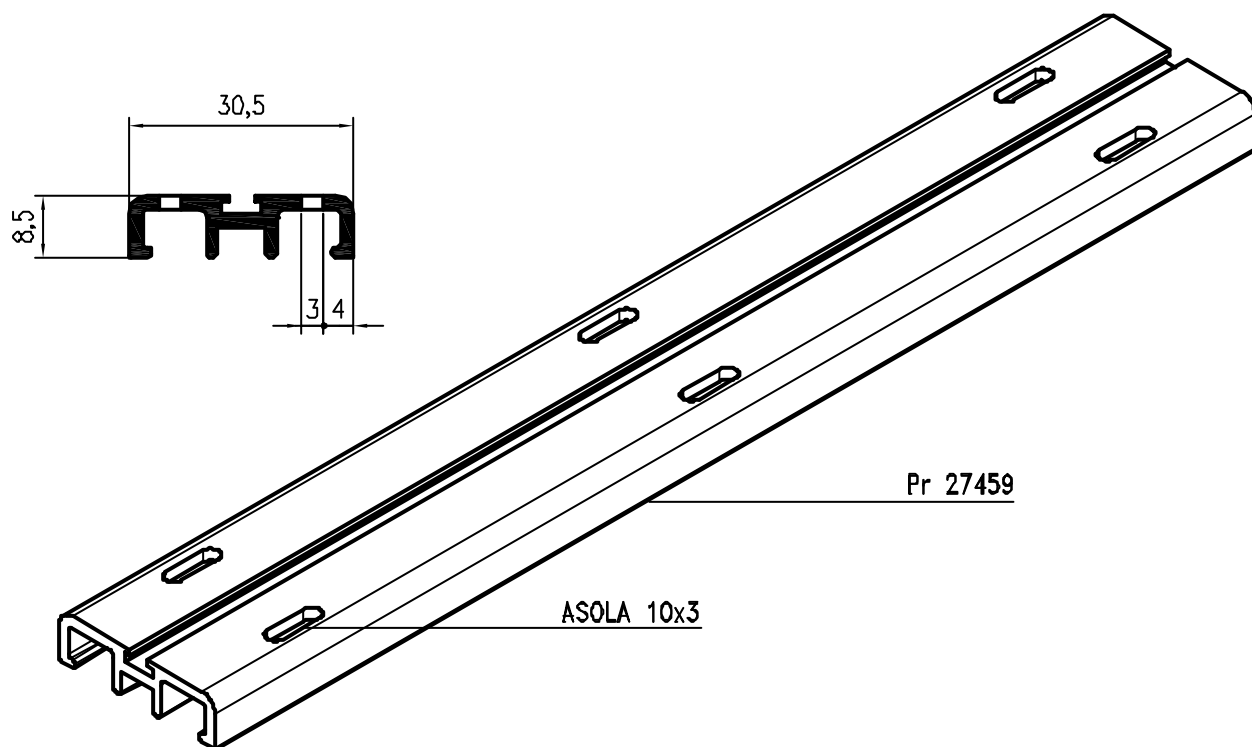
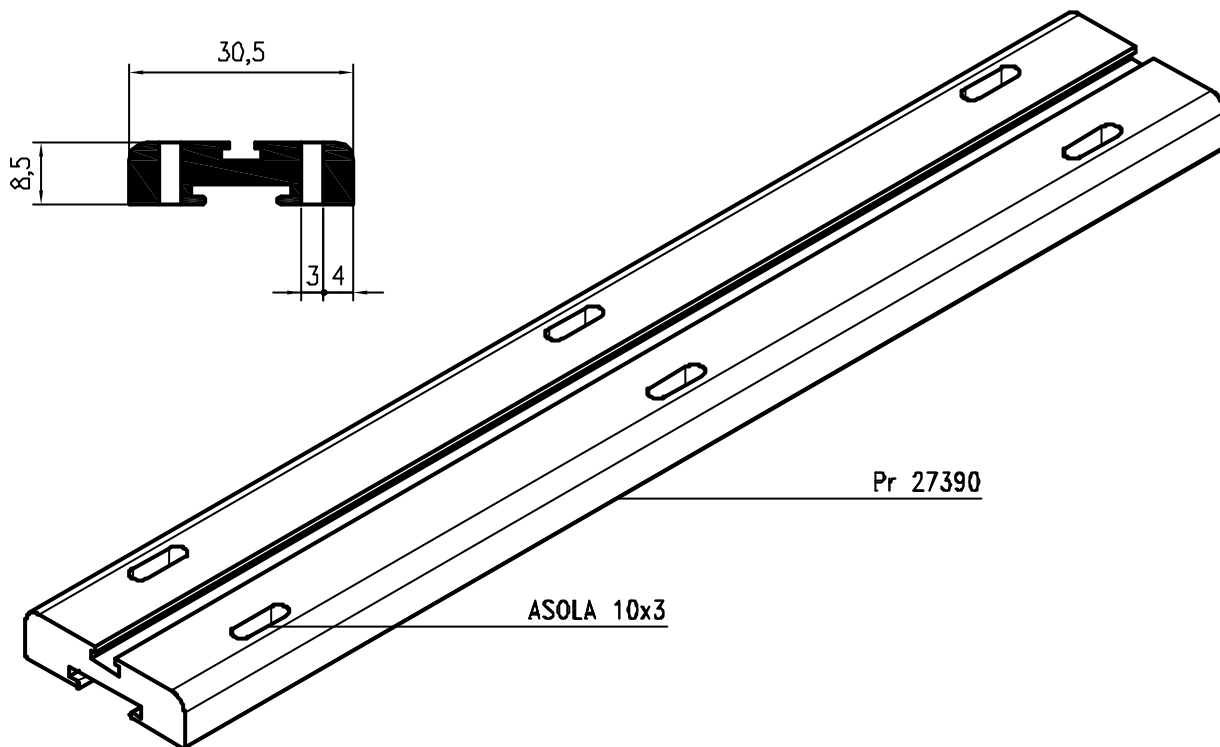

LAVORAZIONE PER TRAVERSI INF. e SUP.



Pr 27390

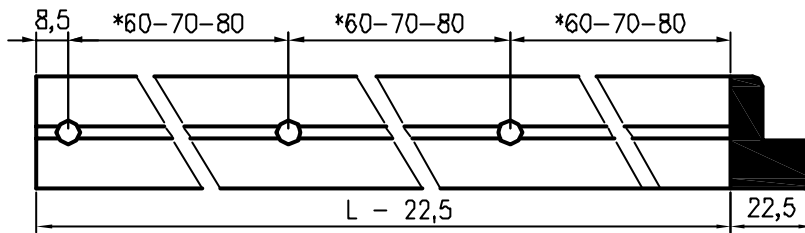

Cod 30 D 106

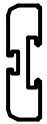
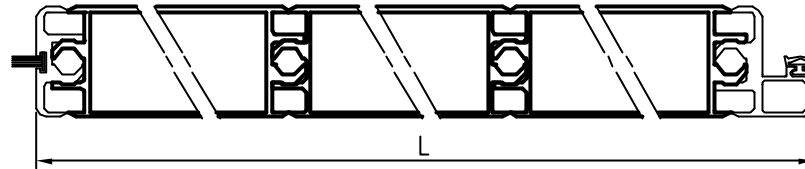

Pr 27390

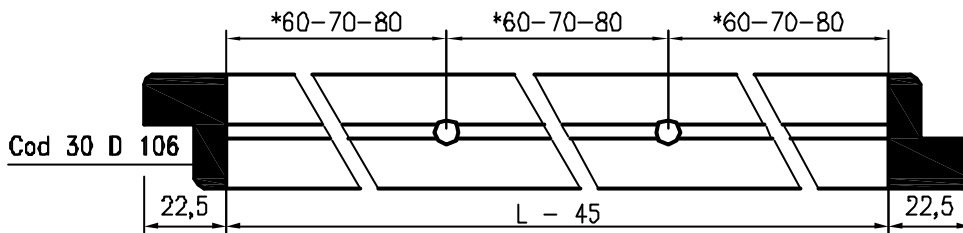

Cod 30 D 106

Cod 30 D 106

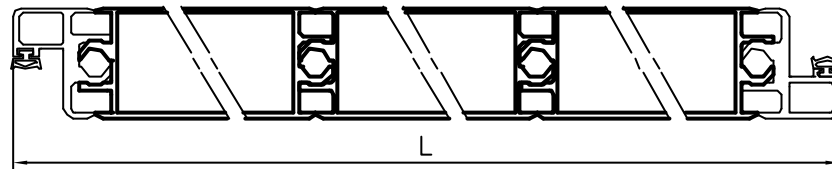

Pr 27459

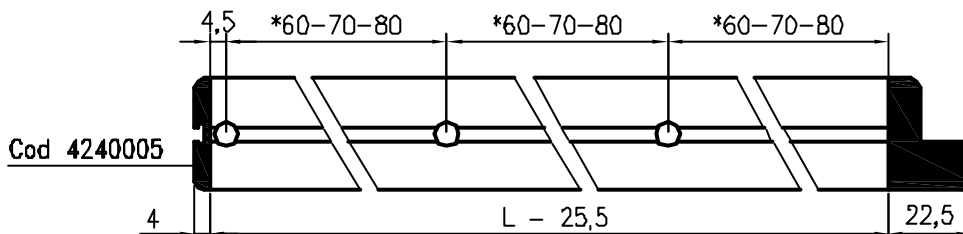

Cod 4240005

Cod 30 D 106

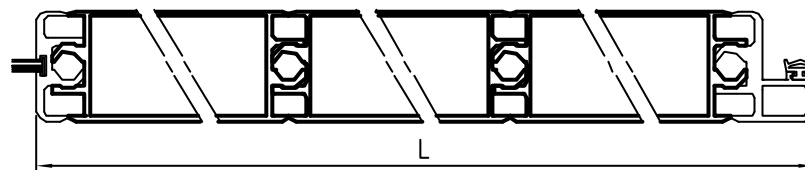

Pr 27459

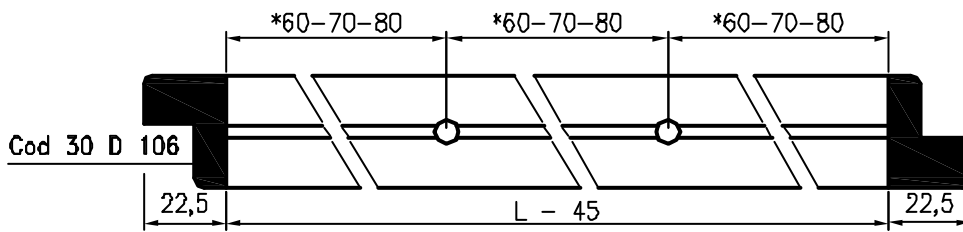

Cod 30 D 106

Cod 30 D 106

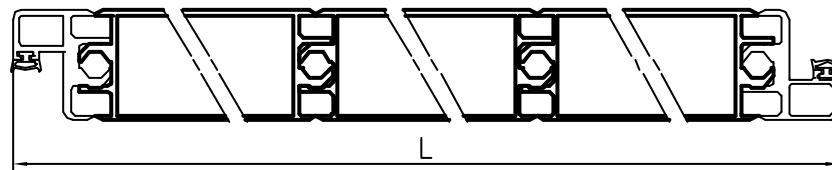

* VARIABILE A SECONDO DELLE DOGHE IMPIEGATE

SCHEMI DI RAPIDA CONSULTAZIONE

TELAIO Pr 27388

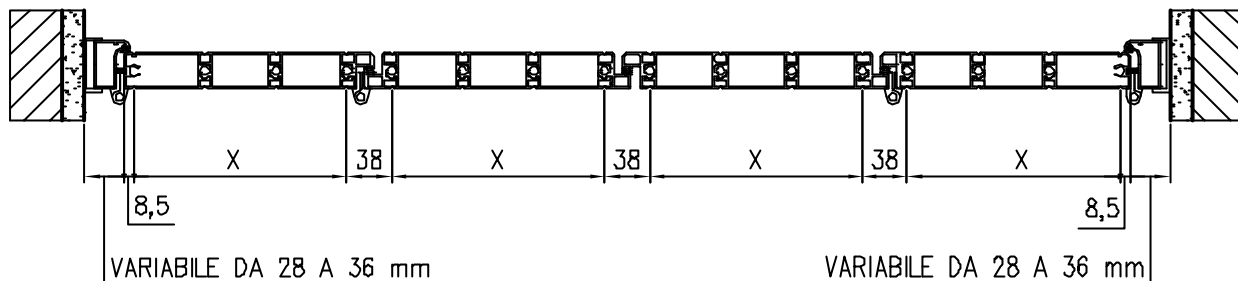

TELAIO Pr 27457

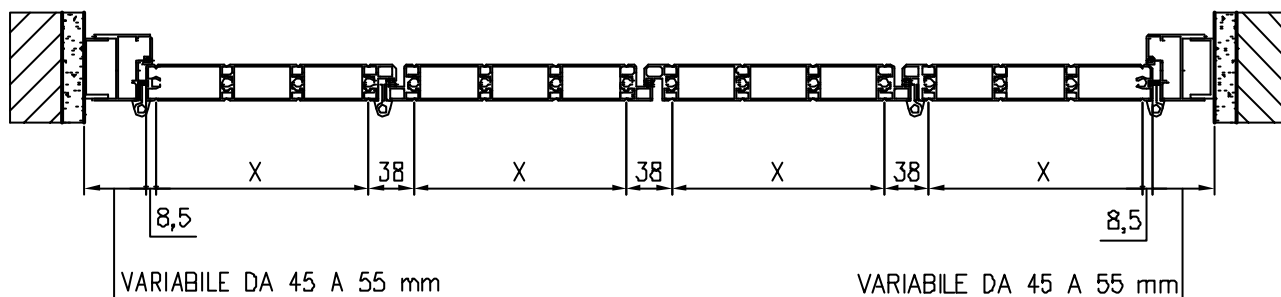

SENZA TELAI

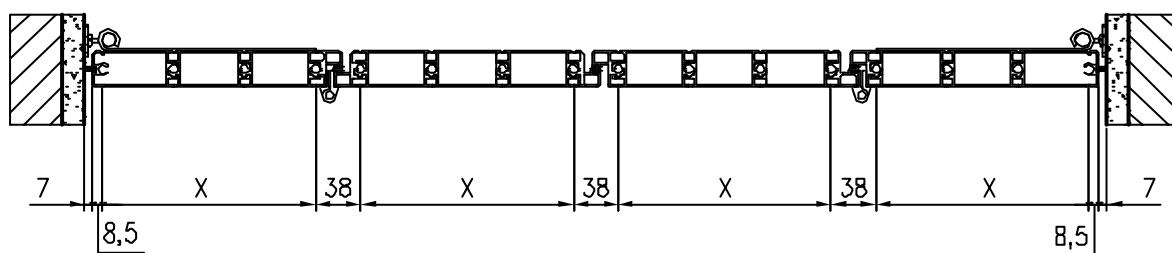

TELAIO Pr 60155

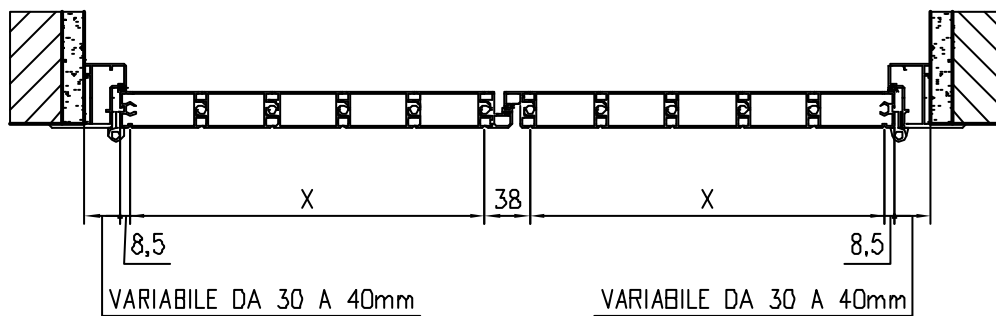

COMPOSIZIONE PANNELLI CON DOGHE SENZA TERMINALI

DIM. DOGHE	60	70	80	160	240	DIM. DOGHE	60	70	80	160	240	DIM. DOGHE	60	70	80	160	240	DIM. DOGHE	60	70	80	160	240		
60	1					330	2	3				420	2	2		1		470		1	2		1		
70		1					3	1	1					3		1	1						1	3	1
80			1			1	4						3		3							1	5		
120	2					3		2				3				1					1		1	1	
130	1	1				3			1			7								1					
140		2				1	3	1					6							1	6				
150		1	1			2	1	2				1	3	2						2	4	1			
160			2			2	1		1			2	1	1	1					3	2	2			
180	3					1	2	2				2	1	1	1					8					
190	2	1				1	2		1			2	1	3							1	1	1		
200	1	2				2		1	1			2	1			1					2	2			
210	1	1	1			2				1		2	1								3		1		
		3				6						6	1								4	1			
220	1		2			1	1	3				1	2	1	1								2		
	1			1		1	1	1	1			1	2			1					1	5	1		
		2	1			1	1			1		2		2	1						2	3	2		
230		1	2			5	1			1		2		4							2	3	1		
		1		1			3		1			2			2						3	1	1		
240	4					3	2					5	2								3	1	3		
			1	1								6	1								3	1			
			3										4	2							7	1	1		
					1								4		1						7				
250	3	1				1		1		1		1	1	1		1					1	4			
						1		4				1	1	2	1							1	4	2	
260	2	2				5		1				1	1	4								2	2	1	
	3		1					2	1	1		1	1		2							2	2	3	
270	1	3						2			1	4	3									2	2		
												2										1	1	1	
280	2			1		3	3					3	3									3	1	1	
	2			2			1	1		1			3	1	1							3	2	1	
		4					1	2	1				3	3								3	4		
290	1	1		1			1	4					3			1						3		2	
	1	1	2				1		2													7	1		
		3	1																			6	2		
300	1		3			2	4					1		2	1							6	1		
	1				1	4		2				1		5											
		2	2						1	2		1			1	1						1	3	1	
		2		1					2		1	3	4									1	3	3	
	5								3	1		4	2	1								1	3		
310	4	1							5				2	1		1						2	1	1	
		1	1	1							1		2	2	1							2	1	1	
		1	3								1		2	4								2	1	4	
		1			1								2		2							2	1	2	
320	3	2		1	1		1	5					2	5								5	3		
							2	3	1				3	3	1							5	2		
							3	1	2				4	1	2										
							3	1		1			4	1		1									
					2		1	4	1				1	1	2										
							2	2	2																

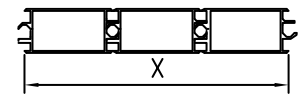

PROSPETTO ESTERNO

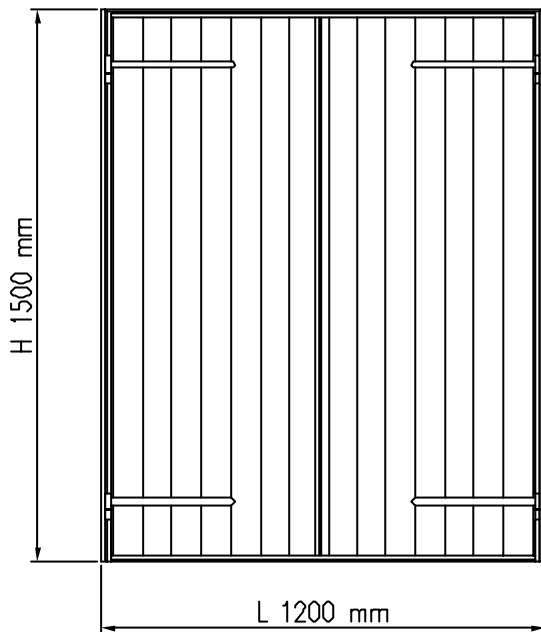

PESO TEORICO			
DIMENSIONI mm 1200x1500			
Sagoma	N° Pezzi	Profilati utilizzati	Peso Kg
[2	Pr 01060	1,15
⌋	2	Pr 27388	1,85
⌋	1	Pr 27388	0,74
⌋	2	Pr 27381	2,59
⌋	2	Pr 27385	1,64
⌋	2	Pr 27459	0,70
⌋	2	Pr 60152	6,05
⌋	4	Pr 60153	11,42
Peso totale			26,14

PROSPETTO ESTERNO

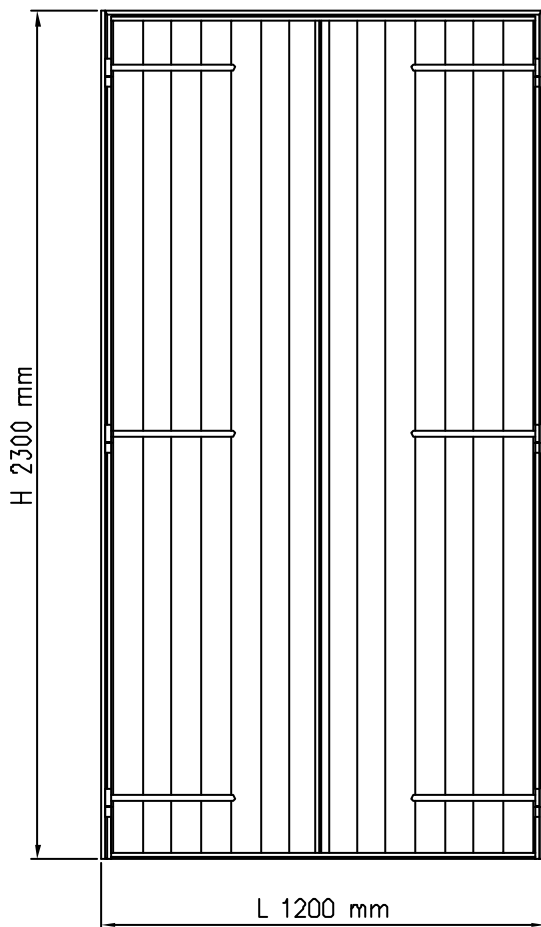

PESO TEORICO			
DIMENSIONI mm 1200x2300			
Sagoma	N° Pezzi	Profilati utilizzati	Peso Kg
[2	Pr 01060	1,76
⌋	2	Pr 27388	2,84
⌋	1	Pr 27388	0,74
⌋	2	Pr 27381	3,97
⌋	2	Pr 27385	2,52
⌋	2	Pr 27459	0,70
⌋	2	Pr 60152	9,28
⌋	4	Pr 60153	17,52
Peso totale			39,33

PROSPETTO ESTERNO

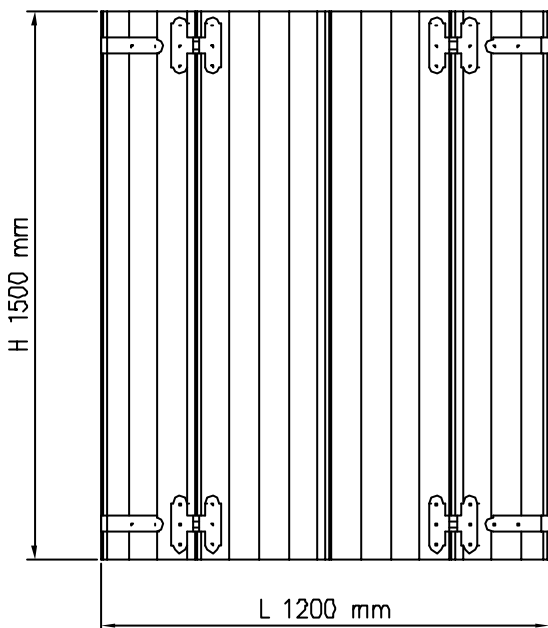

PESO TEORICO			
DIMENSIONI mm 1200x1500			
Sagoma	N° Pezzi	Profilati utilizzati	Peso Kg
	2	Pr 27381	2,59
	5	Pr 27385	4,11
	1	Pr 27393	0,83
	2	Pr 27459	0,70
	2	Pr 60152	6,05
	4	Pr 60153	11,42
Peso totale			25,70

PROSPETTO ESTERNO

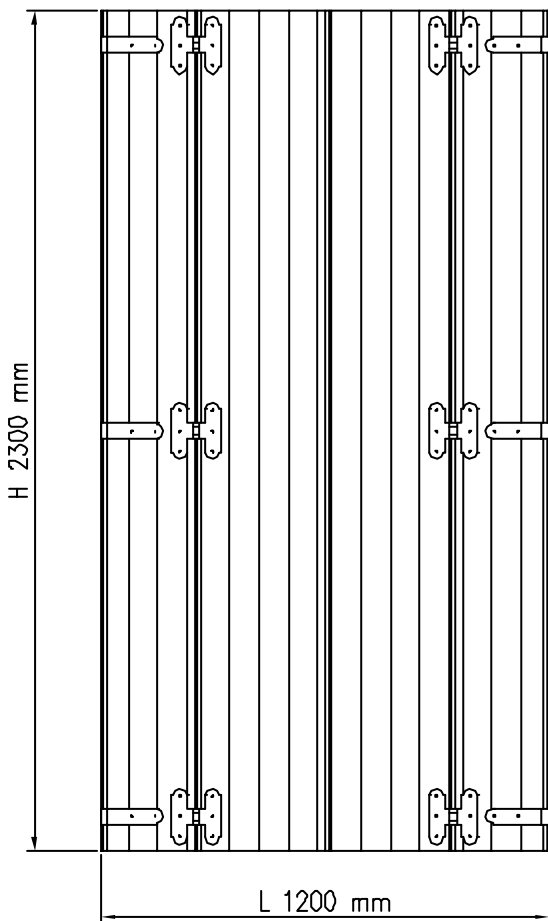

PESO TEORICO			
DIMENSIONI mm 1200x2300			
Sagoma	N° Pezzi	Profilati utilizzati	Peso Kg
	2	Pr 27381	3,97
	5	Pr 27385	6,30
	1	Pr 27393	1,28
	2	Pr 27459	0,70
	2	Pr 60152	9,28
	4	Pr 60153	17,52
Peso totale			39,05









DOMAL SUNNY GENOVESE









Hydro
Building
Systems

INDICE SUNNY GENOVESE

DESCRIZIONE	da pag.	a pag.
INDICE		235
ACCESSORI	237	248
SAGOMARIO PROFILATI	249	252
PROFILATI 1:1	253	258
SCHEMI E DISTINTE	259	265
SEZIONI 1:1		266

ACCESSORI	CODICE	COLORE	DESCRIZIONE	MATER.	CONFEZ.
	AW 050	GREZZO RAL1004K RAL6005K RAL7001K RAL8014 RAL9005 RAL9010	BRACCETTO PER SPORTELLO ALLA GENOVESE	ALLUMINIO	PEZZI 200
	AW 070	GREZZO RAL1004K RAL6005K RAL7001K RAL8014 RAL9005 RAL9010	CARDINE A MURARE	ACCIAIO	PEZZI 50
	AW 100	GREZZO RAL1004K RAL6005K RAL7001K RAL8014 RAL9005 RAL9010	CANTONALE CON OCCHIELLO PIANO	ALLUMINIO	PEZZI 50
	AW 101	GREZZO RAL1004K RAL6005K RAL7001K RAL8014 RAL9005 RAL9010	SELLA REVERSIBILE PER OVALINA 50 mm. Pr 50013	NYLON	PEZZI 750
	AW 102	GREZZO RAL1004K RAL6005K RAL7001K RAL8014 RAL9005 RAL9010	SELLA REVERSIBILE PER OVALINA 65 mm. Pr 50012	NYLON	COPPIA 250
	AW 106	RAL6005K RAL8017 RAL9005	SELLA REVERSIBILE PER OVALINA 80 mm. Pr 50016	NYLON	PEZZI 300
	AW 112	GREZZO RAL1004K RAL6005K RAL7001K RAL8014 RAL9005 RAL9010	CERNIERA REVERSIBILE CON PIASTRINA A INFILARE PER PERSIANA A 2-3 ANTE TELAI Pr 50001-50002 ANTA Pr 50028	ALLUMINIO	PEZZI 50
	AW 160	GREZZO RAL1004K RAL6005K RAL7001K RAL8014 RAL9005 RAL9010	CERNIERA IN LAMIERA PER SPORTELLO GENOVESE	ALLUMINIO	PEZZI 100

ACCESSORI	CODICE	COLORE	DESCRIZIONE	MATER.	CONFEZ.
	AW 190	GREZZO RAL1004K RAL6005K RAL7001K RAL8014 RAL9005 RAL9010	BATTENTE A "Z"	ALLUMINIO	PEZZI 100
	AW 203	GREZZO	SQUADRETTA PER TUBOLARE 45x20 mm.	ALLUMINIO	PEZZI 200
	AW 204	GREZZO	SQUADRETTA PER TUBOLARE 45x30 mm.	ALLUMINIO	PEZZI 150
	AW 301	RAL6005K RAL9005 RAL9010	SELLA REVERSIBILE CON SPESSORE PER OVALINA DA 50 mm. Pr 50013	NYLON	PEZZI 1000
	AW 302	NERO	GIUNTO PER FASCE Pr 50032-50033-50036 (FOX) PER SPORTELLO	NYLON	PEZZI 300
	AW 303	NERO	GIUNTO PER FASCE ABBINAMENTO TRAVERSI Pr 50017 - 50034	NYLON	PEZZI 300
	AW 304	NERO	TAPPO ACCOPPIAMENTO Pr 50028 - 50031	NYLON	PEZZI 200

ACCESSORI	CODICE	COLORE	DESCRIZIONE	MATER.	CONFEZ.
	AW 379	GREZZO	KIT DI COLLEGAMENTO E FISSAGGIO, GUIDATO PER TUBOLARITA' DA 27mm.	ALLUMINIO	PEZZI 30
	AW 400	NERO	ESPANSORE PERSIANA (OK RED)	NYLON	PEZZI 200
	AW 401	NERO	GIUNTO PER FASCE Pr 50032-50033-50036 (FOX) PER PARTI FISSE	NYLON	PEZZI 300
	AW 402	NERO	TAPPO CHIUDI TUBOLARITA' PER Pr 50026-50030	NYLON	PEZZI 200
	AW 403	NERO	TAPPO CHIUDI TUBOLARITA' PER Pr 50028-50031	NYLON	PEZZI 200
	AW 404	RAL6005K RAL9005	SELLA DOPPIA PER FRANCESINA Pr 50038 USARE CON OVALINA Pr 50013	NYLON	PEZZI 1000
	AW 410	NERO	BATTUTA A CILINDRO IN NYLON	NYLON	PEZZI 100
	AW 411	GREZZO	CAVALLOTTO PER Pr 50035	ACCIAIO	PEZZI 100

ACCESSORI	CODICE	COLORE	DESCRIZIONE	MATER.	CONFEZ.
	AW 421	NERO	TAPPO PER T/Z INCONTRO CENTRALE ANTE PER Pr 50026	NYLON	COPPIE 120
	AW 425	NERO	INCONTRO PER ASTA E TERZA CHIUSURA PER Pr 50025 - 50027	NYLON ACCIAIO	PEZZI 100
	AW 450	NERO	TAPPO DX/SX CHIUDI TUBOLARITA' PER Pr 50044	NYLON	COPPIE 100
	AW 518	NERO	CHIOCCIOLA PER SPORTELLO ALLA GENOVESE	NYLON	PEZZI 2
	AW 600	NERO	BLOCCETTO PER LAVORAZIONE FRANCESINA Pr 50035	NYLON	PEZZI 100 (200 VITI)
	13 C 15	GREZZO	KIT DI COLLEGAMENTO PER APERTURE ESTERNE mm 45 mm 52	ALLUMINIO	PEZZI 20
	30 B 50	GREZZO RAL6005 RAL8014 RAL8017 RAL9005 RAL9010 VPV	CERNIERA REVERSIBILE CON PIASTRINA DI AGGANCIO PER PERSIANA A 2-3 ANTE TELAI Pr 50025-50027 ANTA Pr 50026	ALLUMINIO	PEZZI 50





ACCESSORI	CODICE	COLORE	DESCRIZIONE	MATER.	CONFEZ.
	30 D 44	NERO	FERMO IMPOSTA AUTOMATICO GRILLO	NYLON	PEZZI 10
	30 D 48	NERO	FERMO IMPOSTA AUTOMATICO GRILLO TOP, CON AMMORTIZZATORE	NYLON	PEZZI 10
	30 S 20	GREZZO	INCONTRO PER SERRATURE DA MONTANTE	NYLON	PEZZI 10
	30 S 21	GREZZO	INCONTRO PER DEVIATORI SUPPLEMENTARI	NYLON	PEZZI 10
	33 D 02	NERO	TAPPO CHIUDI TUBOLARITA' Pr 24452	POLIPRO- PILENE	PEZZI 100
	40 C 02	GREZZO	KIT DI COLLEGAMENTO E FISSAGGIO, GUIDATO, PER TUBOLARITA' DA 10,5mm.	ALLUMINIO	PEZZI 20
	40 C 03	GREZZO	PERNO DI COLLEGAMENTO TRA KIT + ASTINA + CREMONESE PER APERTURE ESTERNE PER Cod. 40 C 02	ACCIAIO	PEZZI 200

ACCESSORI	CODICE	COLORE	DESCRIZIONE	MATER.	CONFEZ.
	33B101	RAL9005	BANDELLA VERTICALE PER CERNIERA	ACCIAIO	PEZZI 20
	33C100	RAL9005	CONFEZIONE BASE SPAGNOLETTA PICCOLA 2 ANTE	ZAMA	PEZZI 20
	33C101	RAL9005	CONFEZIONE BASE SPAGNOLETTA PICCOLA 1 ANTA	ZAMA	PEZZI 20
	33C102	RAL9005	CONFEZIONE BASE SPAGNOLETTA A SCATTO	ZAMA	PEZZI 20
	33C103	RAL9005	PERNO DI CHIUSURA DIRITTO	ACCIAIO	PEZZI 50
	33C104	RAL9005	PIASTRA DI CHIUSURA AD ANGOLO	ACCIAIO	PEZZI 20
	33C105	RAL9005	GUIDA ASTE	ZAMA	PEZZI 50
	33C106	RAL9005	CHIUSURA VERTICALE AD ESPANSIONE DX. CONFEZIONE BASE	ZAMA/ACC.	PEZZI 20







ACCESSORI	CODICE	COLORE	DESCRIZIONE	MATER.	CONFEZ.
	33C107	RAL9005	CHIUSURA VERTICALE AD ESPANSIONE SX. CONFEZIONE BASE	ZAMA/ACC.	PEZZI 20
	33C108	RAL9005	COMPENSATORE DI ROTAZIONE 180° DX. PER Cod. 33C106	ZAMA	PEZZI 50
	33C109	RAL9005	COMPENSATORE DI ROTAZIONE 180° SX. PER Cod. 33C107	ZAMA	PEZZI 50
	33C110	RAL9005	POZZETTO PER SOGLIA	ZAMA	PEZZI 50
	33C114	RAL9005	BUSSOLE FILETTATE PER Cod. 33C115	ZAMA	PEZZI 100
	33C115	GREZZO	VITE 50mm PER Cod. 33C114	INOX	PEZZI 100
	33C116	RAL9005	ASTA DI CHISURA 1800mm	ACCIAIO	PEZZI 10
	33C117	RAL9005	ASTA DI CHISURA 2400mm	ACCIAIO	PEZZI 10





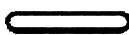

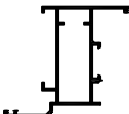
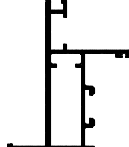
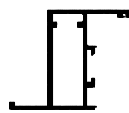
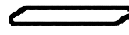
ACCESSORI	CODICE	COLORE	DESCRIZIONE	MATER.	CONFEZ.
	33C118	RAL9005	ASTA DI CHIUSURA 3200mm	ACCIAIO	PEZZI 10
	33C130	RAL9005	PERNO DI CHIUSURA M8	ACCIAIO	PEZZI 50
	33C131	RAL9005	PERNO DI CHIUSURA Ø10 DA INCOLLARE	ACCIAIO	PEZZI 50
	33C132	RAL9005	PERNO DI CHIUSURA ECCENTRICO	ACC.-ABS	PEZZI 10
	33D100	RAL9005	ROSETTA COPRIFORO CARDINE	ABS	PEZZI 100
	33D101	GREZZO	TASSELLO 100mm	ABS	PEZZI 50
	33D102	GREZZO	TASSELLO 135mm	ABS	PEZZI 50





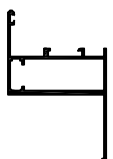
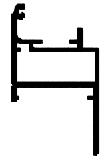
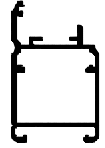
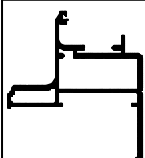
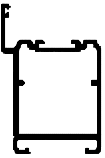

ACCESSORI	CODICE	COLORE	DESCRIZIONE	MATER.	CONFEZ.
	60 C 50	RAL1013 RAL6005 RAL8017 RAL9005 RAL9010	CREMONESE "MANON" CON CHIAVE PER APERTURE ESTERNE	PRESSO- FUSO	PEZZI 10
	71 C 73	VER.NAT. RAL1013 RAL6005 RAL8017 RAL9005 RAL9010	CREMONESE IN ALLUMINIO "MAXIMA" PER APERTURE ESTERNE	ZAMA	PEZZI 10
	71 D 20	NERO	INCONTRO ASTA ESTERNA CON PUNTALE IN ACCIAIO PER Pr 5001 - 5002	NYLON	PEZZI 250
	71 D 21	NERO	TERMINALE ASTA CON PUNTALE IN ACCIAIO	NYLON ACCIAIO	PEZZI 50
	71 D 22	NERO	COPIA CATENACCI PER SCANALATURA ESTERNA	ALLUMINIO	COPIA 25
	80 D 35	NERO	TAPPO CHIUDIFORO DIAMETRO 11,5mm	PVC	PEZZI 1000

SEZIONE	CODICE	DESCRIZIONE	BOBINE m	SCATOLA m
	90 G 26	GUARNIZIONE PER BATTUTA MATERIALE: ELAPRENE COLORE: NERO	400	800
	90 G 29	GUARNIZIONE PER BATTUTA	300	300
	ST G 29	GUARNIZIONE PER DOPPIA BATTUTA MATERIALE: EPDM COLORE: NERO	400	400
	90 G 69	GUARNIZIONE COPRIFILO A MURO PER Pr 50001	100	400
	90 G 82	GUARNIZIONE DI FINITURA PER Pr 50001	50	50

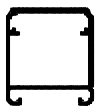
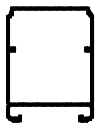
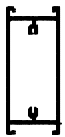
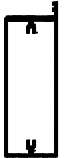
ATTREZZATURE	CODICE	DESCRIZIONE	CONFEZ.
	30 W 85	PUNZONATRICE PER SQUADRETTE AW 203-AW 204	PEZZI 1

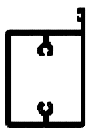
SEZIONE	CODICE Jx cm ⁴ Jy cm ⁴	PESO Kg/m.	SUP. IN VISTA mm.	PAGINA	DESCRIZIONE
	Pr 10763	0,347	111	B06	PROFILATO OVALINA mm. 50
	Pr 11048	0,144	14	B06	PROFILATO ASTA DI CHIUSURA
	Pr 13199	0,448	141	B06	PROFILATO OVALINA mm. 65
	Pr 24452	0,578	101	B05	PROFILATO DI RIPORTO PER ANTA STORICA (Pr 50044)
	Pr 26214	0,923	112	B01	PROFILATO TELAIO
	Pr 50001	1,026	100	B01	PROFILATO TELAIO CON FISSAGGIO A MURO
	Pr 50002	0,845	95	B01	PROFILATO TELAIO
	Pr 50012	0,435	138	B06	PROFILATO OVALINA SAGOMATA mm. 65
	Pr 50013	0,240	111	B06	PROFILATO OVALINA mm. 50 (ALLEGGERITA)
	Pr 50014	0,545	60	B03	PROFILATO CORNICE CENTRO STORICO

SEZIONE	CODICE Jx cm ⁴ Jy cm ⁴	PESO Kg/m.	SUP. IN VISTA mm.	PAGINA	DESCRIZIONE
	Pr 50016	0,554	168	B06	PROFILATO OVALINA mm. 80
	Pr 50017	0,432	49	B03	PROFILATO CORNICE CENTRO STORICO PER Pr 50016
	Pr 50018	1,148	166	B04	PROFILATO DOGA PER SCURI
	Pr 50019	0,505	54	B03	PROFILATO PER MECCANISMI ORIENTABILI
	Pr 50023	0,907	110	B02	PROFILATO TELAIO
	Pr 50025	0,905	134	B02	PROFILATO TELAIO PER Pr 50025
	Pr 50026	0,986	138	B03	PROFILATO ANTA COMPLANARE
	Pr 50027	1,121	151	B01	PROFILATO TELAIO CON FISSAGGIO A MURO
	Pr 50028	0,993	151	B03	PROFILATO ANTA MAGGIORATA A SORMONTO
	Pr 50029	0,656	128	B03	PROFILATO SPORTELLO

SEZIONE	CODICE Jx cm ⁴ Jy cm ⁴	PESO Kg/m.	SUP. IN VISTA mm.	PAGINA	DESCRIZIONE
	Pr 50030	0,764	152	B05	PROFILATO ANTA ABBINAMENTO Pr 50026
	Pr 50031	0,805	169	B05	PROFILATO ANTA SORMONTO ABBINAMENTO Pr 50028
	Pr 50032	1,420	219	B04	PROFILATO FASCIA H 100 mm
	Pr 50033	1,188	315	B02	PROFILATO ZOCCOLO H 122 mm
	Pr 50034	0,497	94	B03	PROFILATO DI CHIUSURA Pr 50017
	Pr 50035	0,597	92	B04	PROFILATO FRANCESINA H 36 mm
	Pr 50036	0,891	210	B02	PROFILATO ZOCCOLO H 62 mm
	Pr 50037	0,213	61	B06	PROFILATO BATTUTA RIPORTATA PER SPORTELLO
	Pr 50038	0,117	40	B06	PROFILATO FRANCESINA A SCATTO
	Pr 50040	0,365	37	B06	PROFILATO DI RIPORTO PER INSERIMENTO PANNELLI

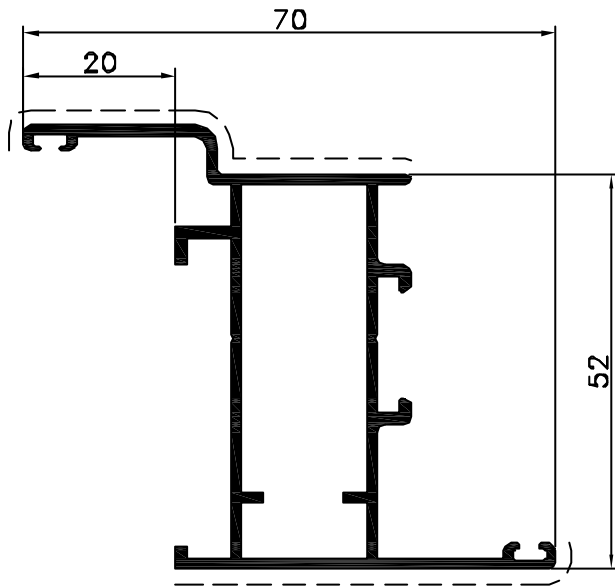

Pr. 26214 kg/m. 0.923
sup. in vista mm. 112

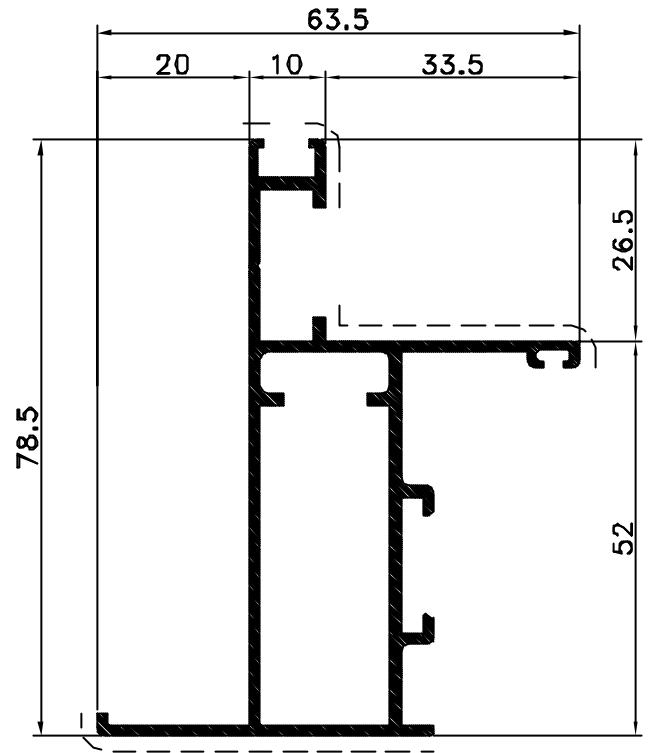

Pr. 50001 kg/m. 1.026
sup. in vista mm. 100

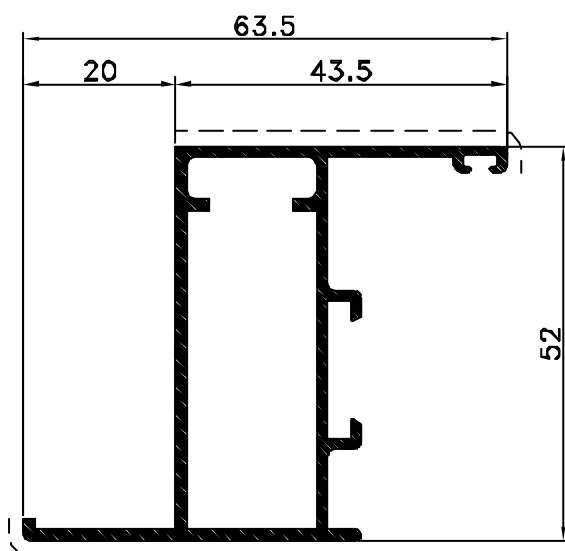

Pr. 50002 kg/m. 0.845
sup. in vista mm. 95

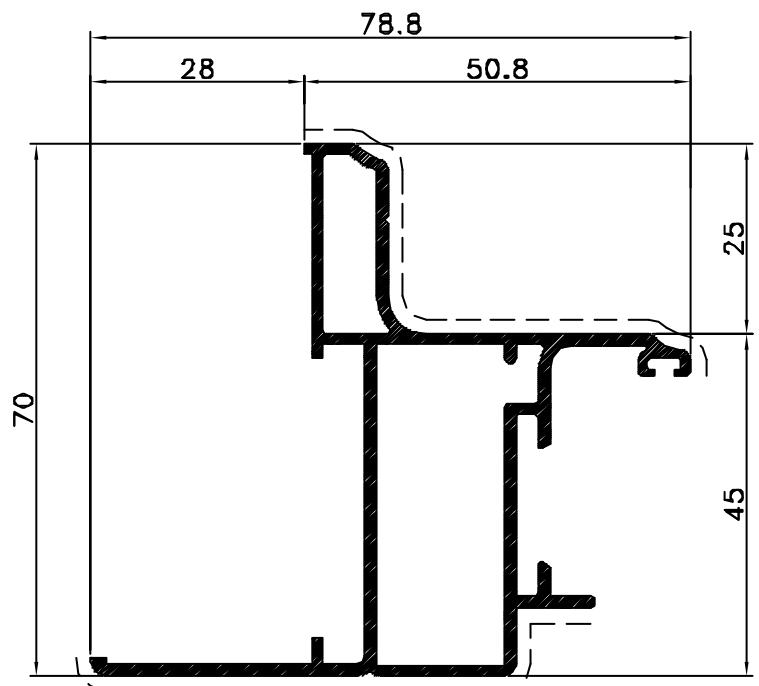

Pr. 50027 kg/m. 1.121
sup. in vista mm. 151

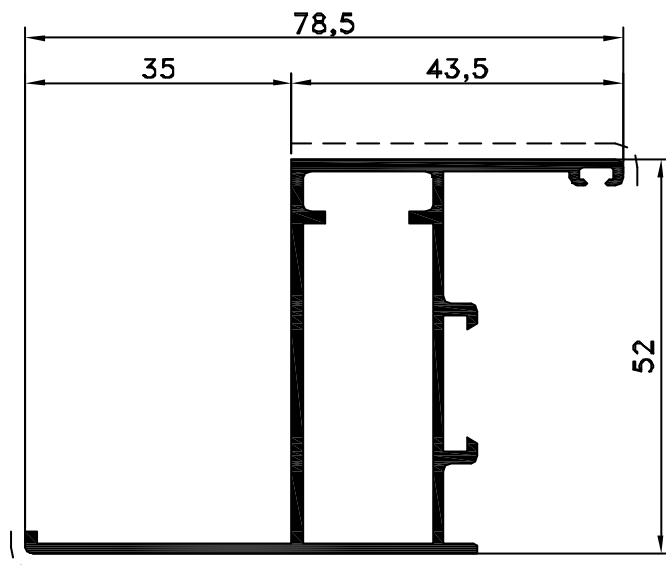

Pr. 50023 kg/m. 0.907
sup. in vista mm. 110

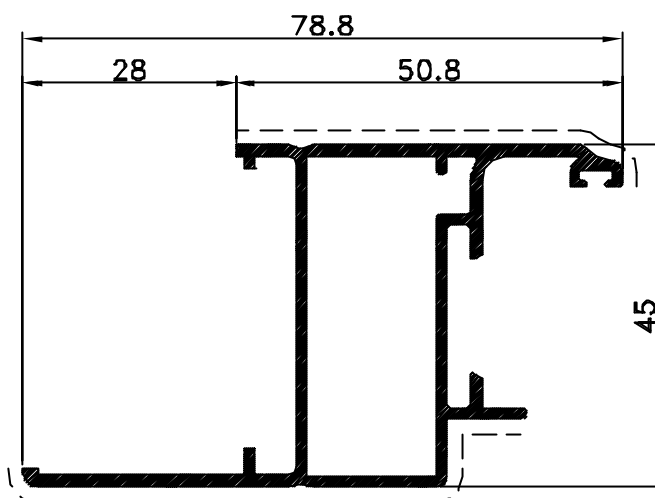

Pr. 50025 kg/m. 0.905
sup. in vista mm. 134

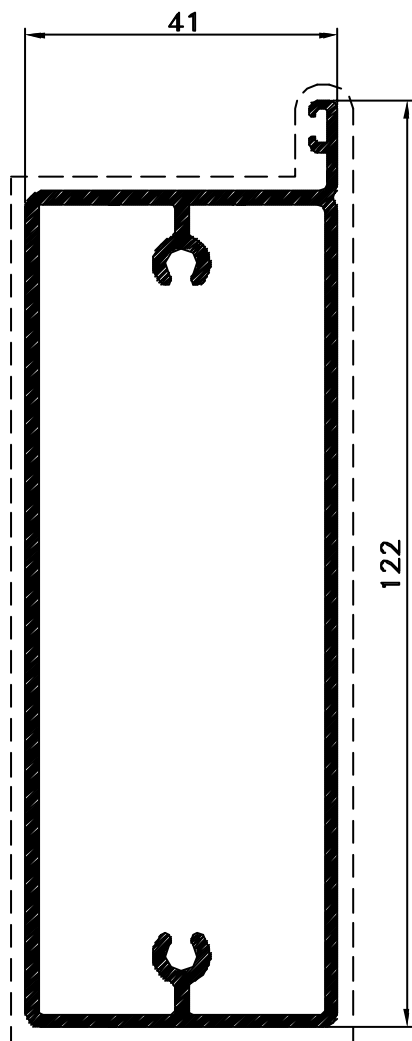

Pr. 50033 kg/m. 1.588
sup. in vista mm. 315

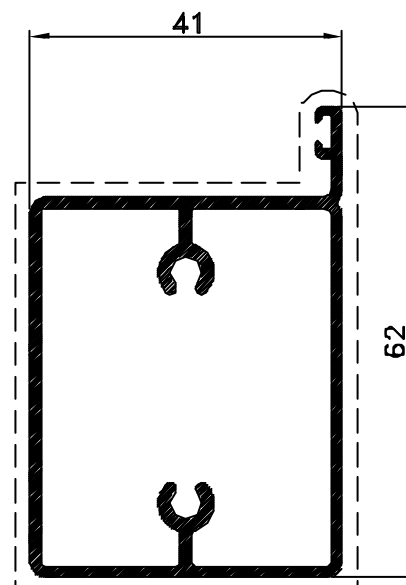

Pr. 50036 kg/m. 0.891
sup. in vista mm. 210

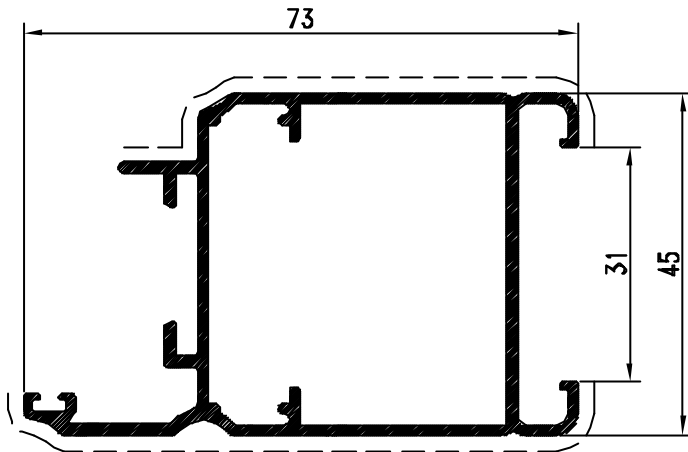

Pr. 50026 kg/m. 0.986
sup. in vista mm. 138

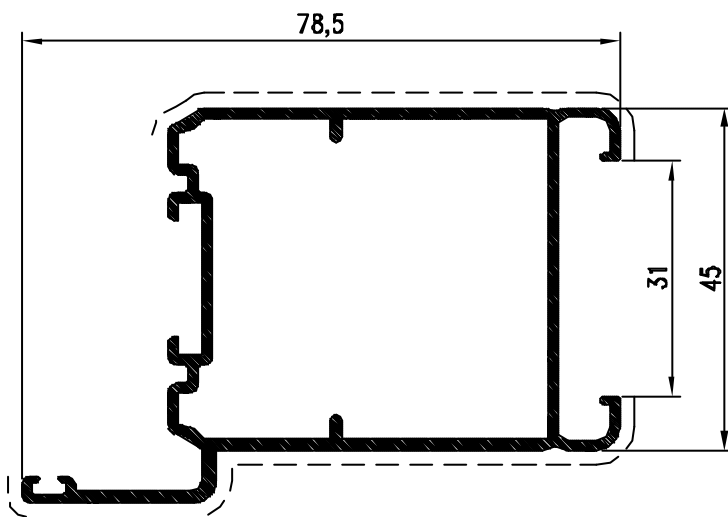

Pr. 50028 kg/m. 0.993
sup. in vista mm. 151

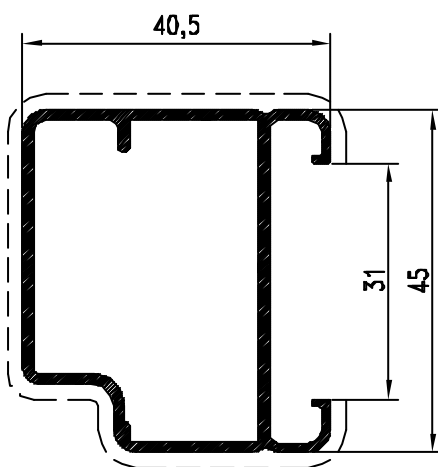

Pr. 50029 kg/m. 0.656
sup. in vista mm. 128

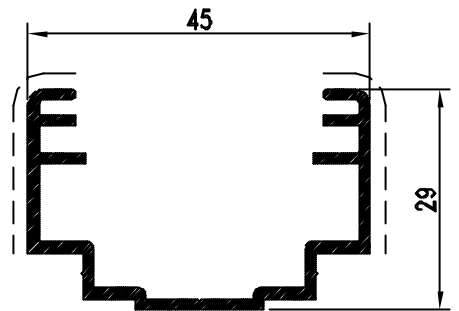

Pr. 50019 kg/m. 0.505
sup. in vista mm. 54

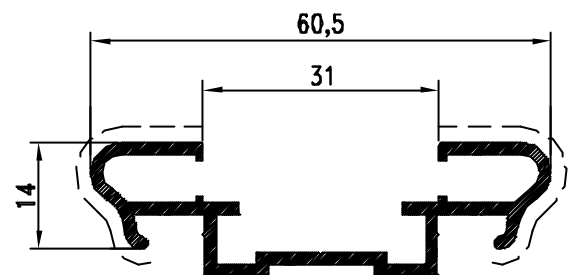

Pr. 50014 kg/m. 0.545
sup. in vista mm. 60

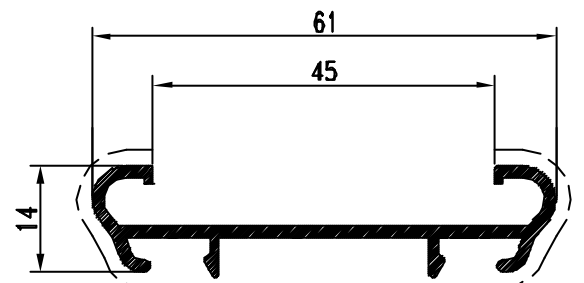

Pr. 50017 kg/m. 0.432
sup. in vista mm. 49

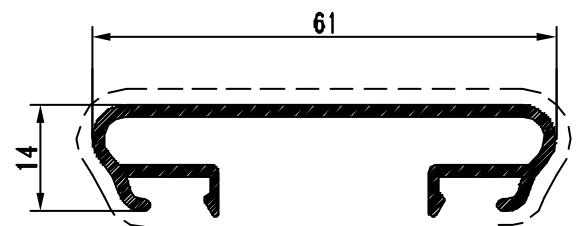

Pr. 50034 kg/m. 0.497
sup. in vista mm. 94

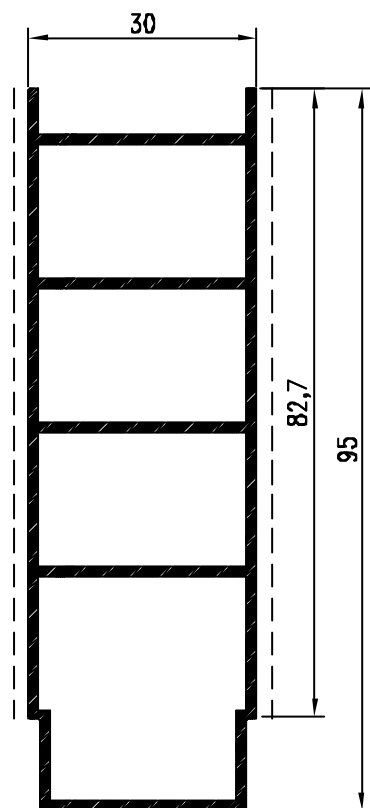

Pr. 50018 kg/m. 1.148
sup. in vista mm. 166

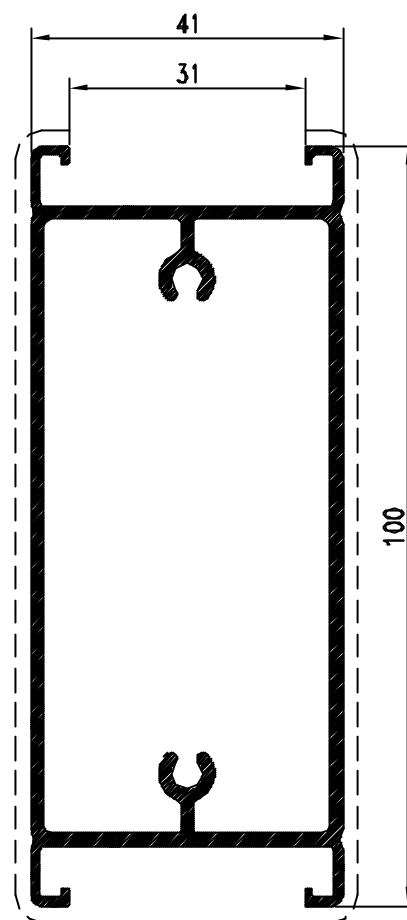

Pr. 50032 kg/m. 1.420
sup. in vista mm. 219

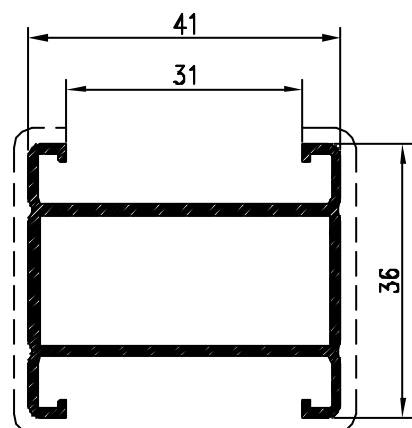

Pr. 50035 kg/m. 0.597
sup. in vista mm. 92

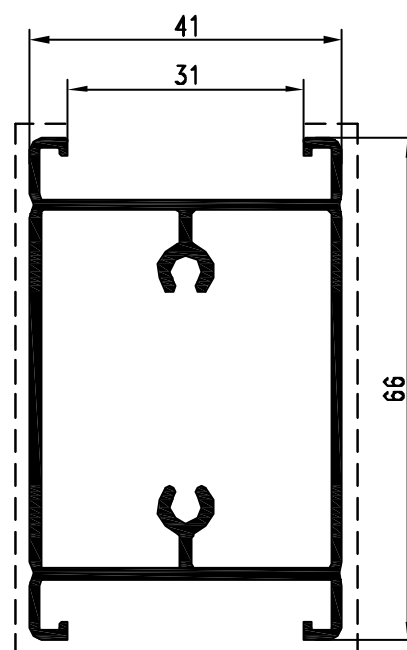

Pr. 50043 kg/m. 0.988
sup. in vista mm. 151

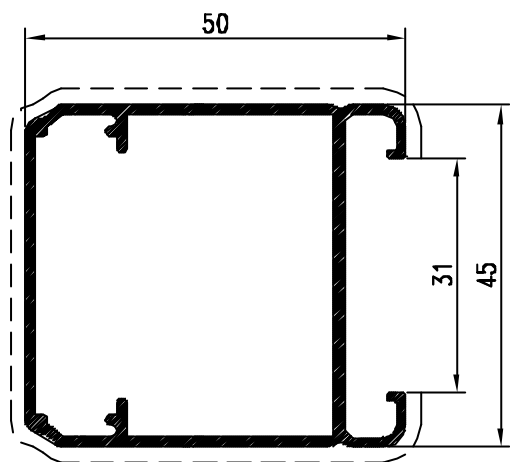

Pr. 50030 kg/m. 0.764
sup. in vista mm. 152

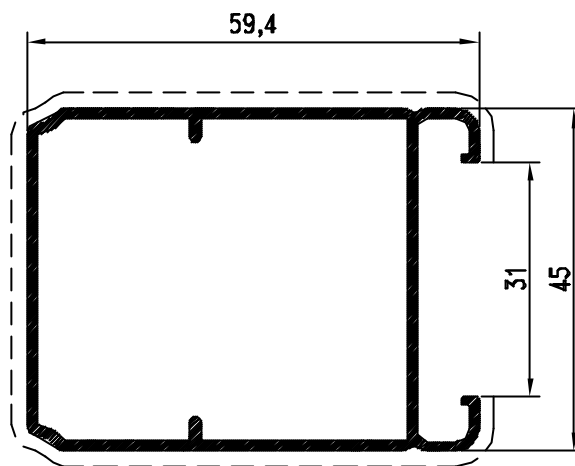

Pr. 50031 kg/m. 0.805
sup. in vista mm. 169

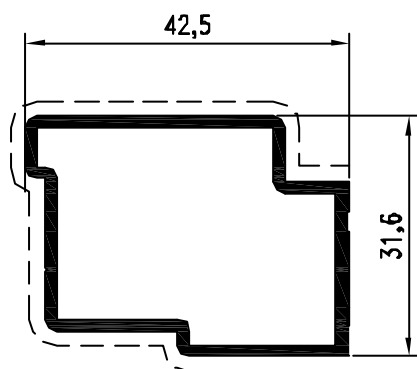

Pr. 24452 kg/m. 0.578
sup. in vista mm. 101

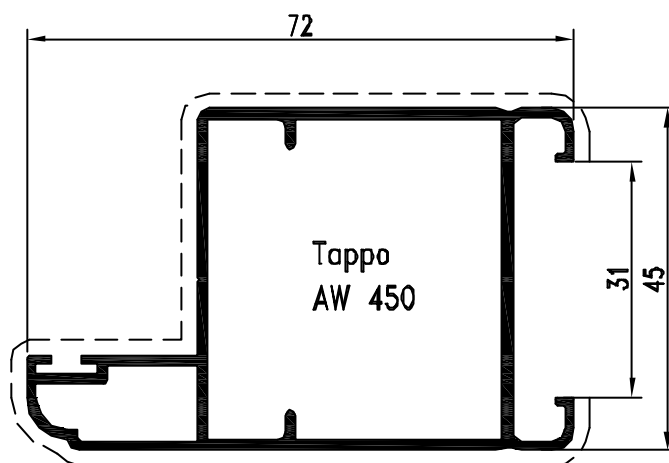

Pr. 50044 kg/m. 0.948
sup. in vista mm. 193

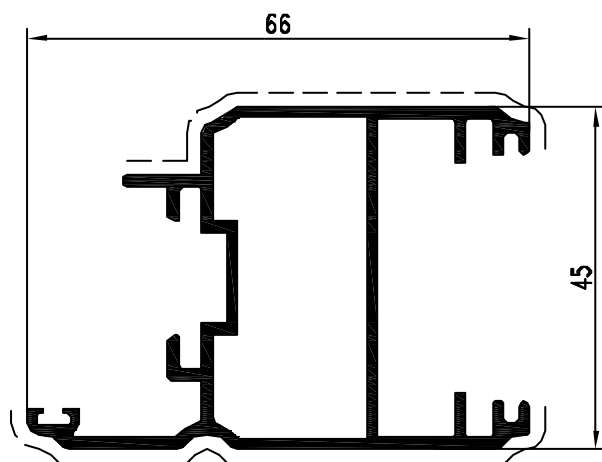

Pr. 50050 kg/m. 0.999
sup. in vista mm. 139

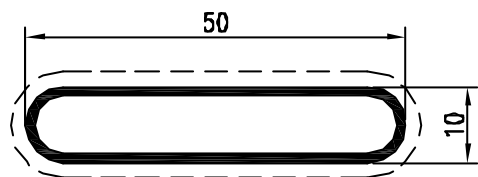

Pr. 10763 kg/m. 0.347
sup. in vista mm. 111

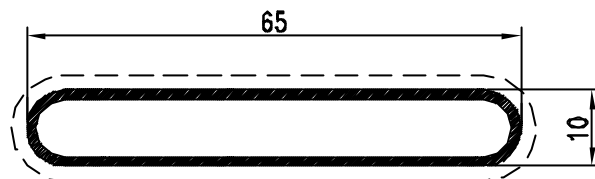

Pr. 13199 kg/m. 0.448
sup. in vista mm. 141

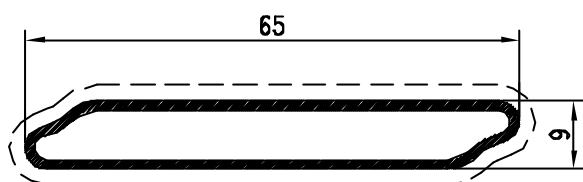

Pr. 50012 kg/m. 0.435
sup. in vista mm. 138

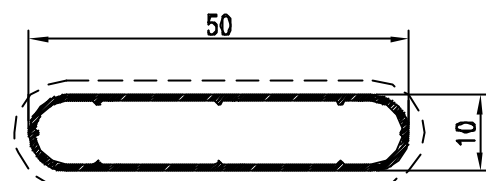

Pr. 50013 kg/m. 0.240
sup. in vista mm. 111

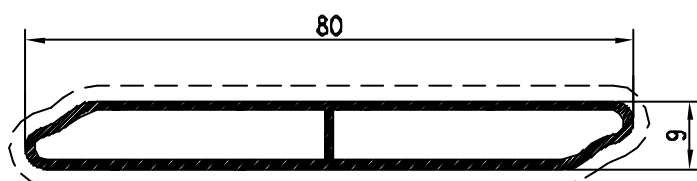

Pr. 50016 kg/m. 0.554
sup. in vista mm. 168

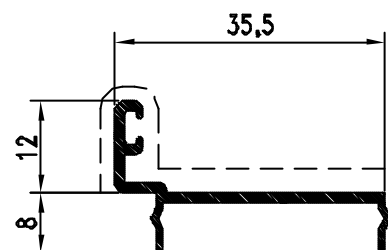

Pr. 50037 kg/m. 0.213
sup. in vista mm. 61

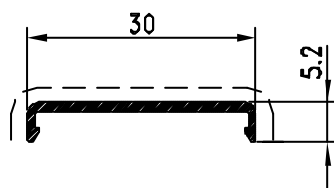

Pr. 50038 kg/m. 0.117
sup. in vista mm. 40

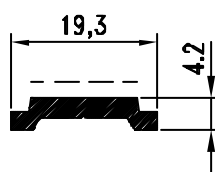

Pr. 11048 kg/m. 0.144
sup. in vista mm. 14

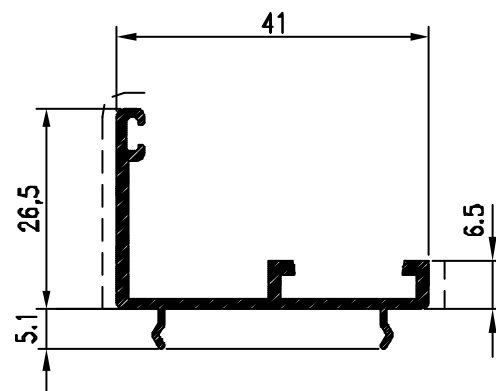

Pr. 50040 kg/m. 0.365
sup. in vista mm. 37

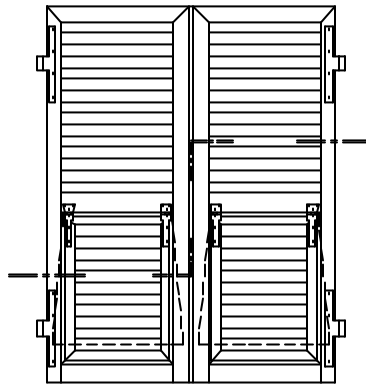

PERSIANA FINESTRA
A 2 ANTE

PROFILI

Nr. Pezzi	Pr	Descrizione	Taglio
2	50030	Montante anta a nuro	H-12
2	50030	Traverso anta a nuro superiore	L/2-18,7
2	50026	Montante centrale anta	H+1
4	50036	Traverso intermedio e inferiore	L/2-118,7
4	50029	Montante sportello	Hs-9
4	50029	Traverso sportello	L/2-127,7
4	50037	Battuta verticale sportello	Hs
1	11048	Astina	H

OVALINE

Nr. Pezzi	Pr	Descrizione	Taglio
$\frac{HF}{40} \times 2$	50013	Ovalina da 50mm per sportello	L/2-192,7
$\frac{Hs-90}{40} \times 2$	50013	Ovalina da 50mm per fisso superiore	L/2-102,7

GUARNIZIONI

Codici	Descrizione	Taglio
90 G 26	Guarnizione di kottuta	2 H
90 G 26	Guarnizione di kottuta per sportello	4 Hs + 2L

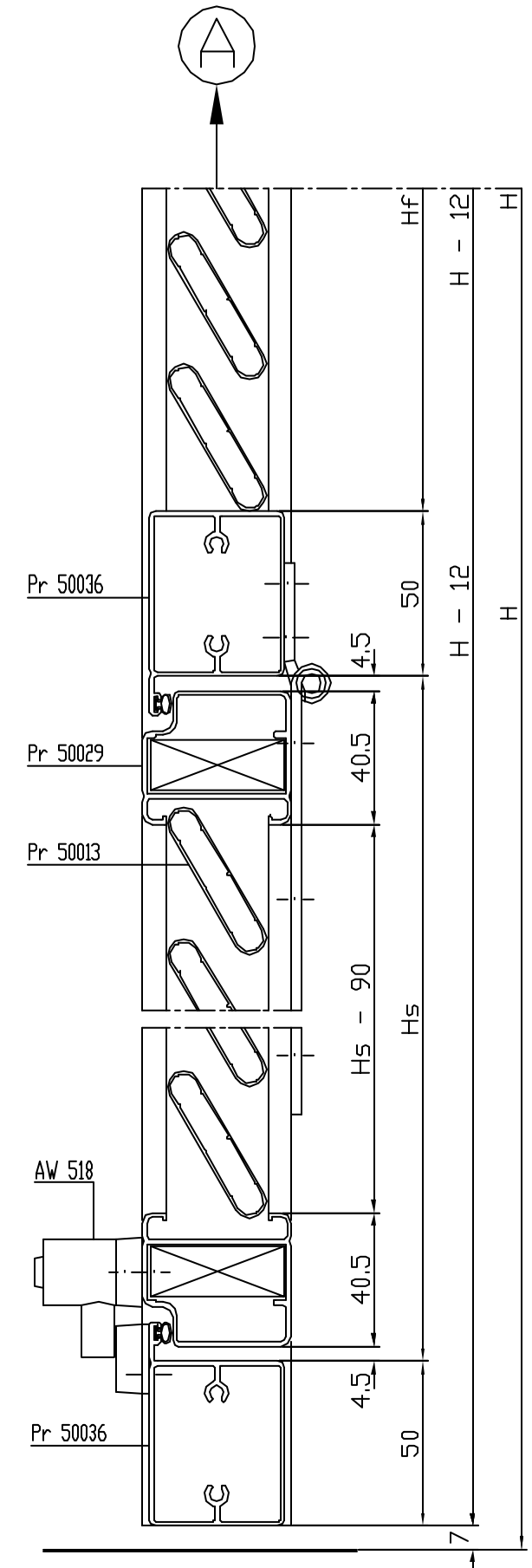
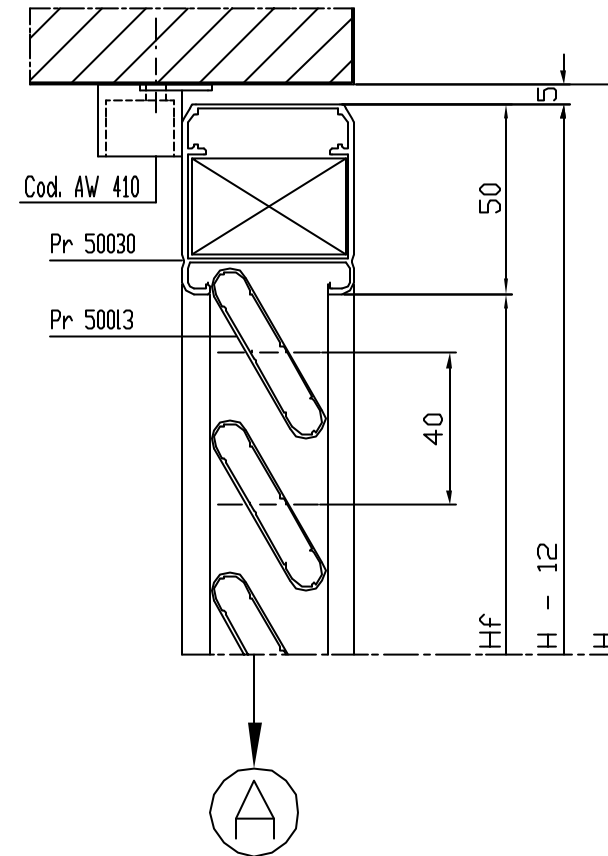

PER LA VERSIONE A TRE ANTE VEDI PAG. C 05

ACCESSORI

Nr. Pezzi	Codici	Descrizione
4	AW 204	Squadretta per Pr 50030
8	AW 203	Squadretta per Pr 50029
4	AW 070	Caroline a murare
4	AW 100	Cantonale con occhio piano
1	7L C 73	Crenonese per aperture esterne
2	7L D 21	Terminale per asta di chiusura
1	40 C 02	Kit di collegamento
2	40 C 03	Perno di collegamento
4	AW 160	Cerniera in lamiera per sportello
2	AW 518	Chiocciolo per sportello
2	AW 050	Braccetto per sportello
8	AW 302	Giunta per fasce (FOX)
1 Coppia	AW 421	Tappo per incontro centrale
4	AW 402	Tappo chiudi tubolarita' Pr 50030-50026
1	AW 410	Battuta a cilindro in nylon

ACCESSORI OVALINE

Nr. Pezzi	Codici	Descrizione
$\frac{HF}{40} \times 4$	AW 101	Sella reversibile parte fissa
$\frac{Hs-90}{40} \times 4$	AW 101	Sella reversibile sportello
16	AW 301	Sella reversibile con spessore

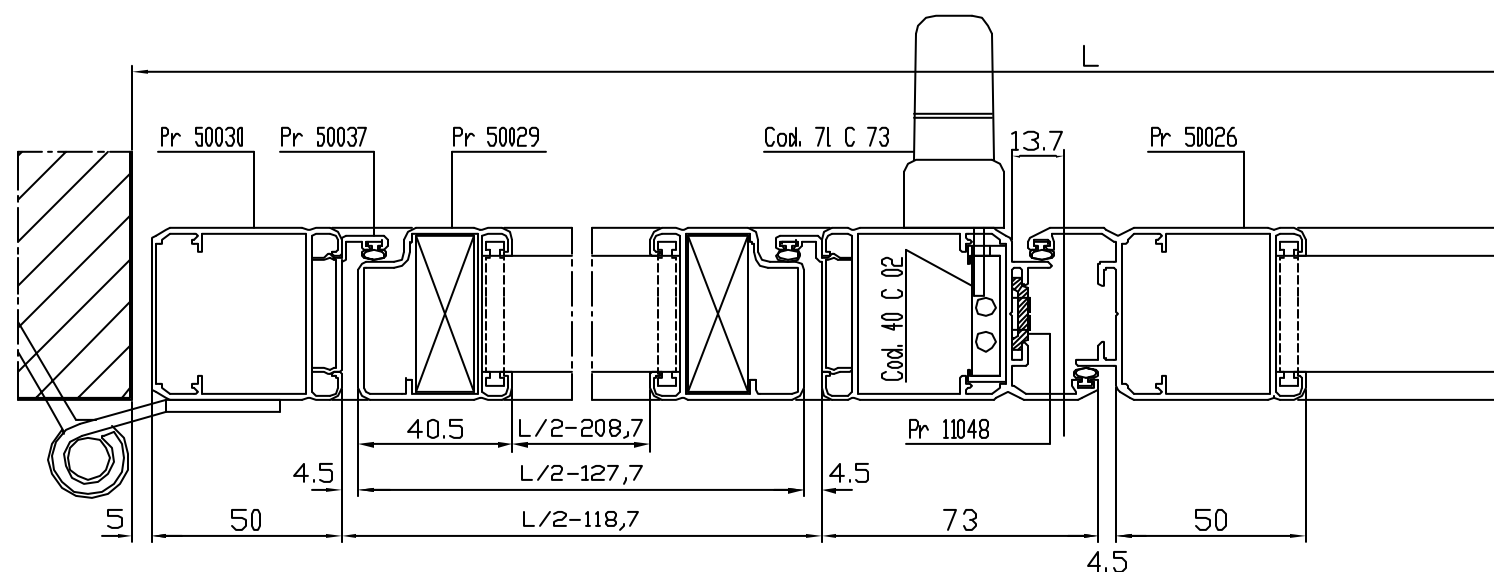

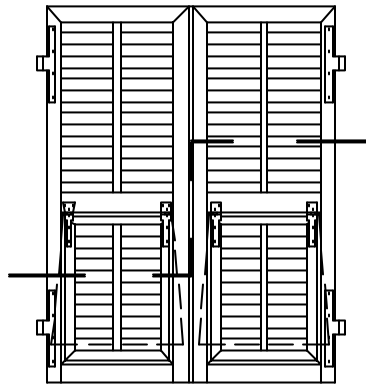

PERSIANA FINESTRA
A 2 ANTE

PROFILI

Nr. Pezzi	Pr	Descrizione	Taglio
2	50031	Montante a muro	H-12
2	50031	Traverso a muro superiore	L/2-114
2	50028	Montante centrale	H+7
2	50036	Traverso internedio	L/2-130,2
2	50033	Zoccolo	L/2-130,2
4	50029	Montante sportello	Hs-9
4	50029	Traverso sportello	L/2-139,2
4	50037	Battuta verticale sportello	Hs
4	50038	Francesina parte fissa	Hf
4	50038	Francesina per sportello	Hs-90
1	11048	Astina	H

OVALINE

Nr. Pezzi	Pr	Descrizione	Taglio
$\frac{Hf}{40} \times 2$	50013	Ovalina da 50mm per sportello	L/2-204,2
$\frac{Hs-90}{40} \times 2$	50013	Ovalina da 50mm per fissa superiore	L/2-114,2

GUARNIZIONI

Codici	Descrizione	Taglio
90 G 26	Guarnizione di battuta	2 H
90 G 26	Guarnizione di battuta per sportello	4 Hs + 2L

ACCESSORI

Nr. Pezzi	Codici	Descrizione
4	AW 204	Squadretta per Pr 50031
8	AW 203	Squadretta per Pr 50029
4	AW 070	Caroline a murare
4	AW 100	Cantonale con occhiello piano
2	40 C 03	Perno di collegamento
1	71 C 73	Cremonese per aperture esterne
2	71 D 21	Terminale per asta di chiusura
1	AW 379	Kit di collegamento
4	AW 160	Derriera in laniera per sportello
2	AW 518	Chiacchiera per sportello
2	AW 050	Braccetta per sportello
8	AW 302	Giunta per fasce (FOX)
4	AW 403	Tappo chiudi tubolarita' Pr 50031-50028
1	AW 410	Battuta a cilindro in nylon

ACCESSORI OVALINE

Nr. Pezzi	Codici	Descrizione
$\frac{Hf}{40} \times 4$	AW 101	Sella reversibile parte fissa
$\frac{Hs-90}{40} \times 4$	AW 101	Sella reversibile sportello
$\frac{Hf}{40} \times 2$	AW 404	Doppia sella francesina per parte fissa
$\frac{Hs-90}{40} \times 2$	AW 404	Doppia sella francesina per sportello
16	AW 301	Sella reversibile con spessore

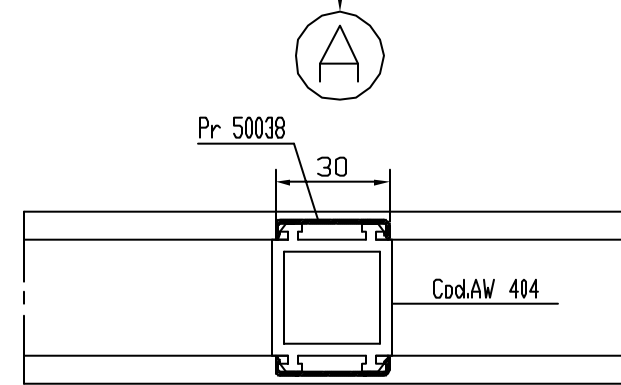
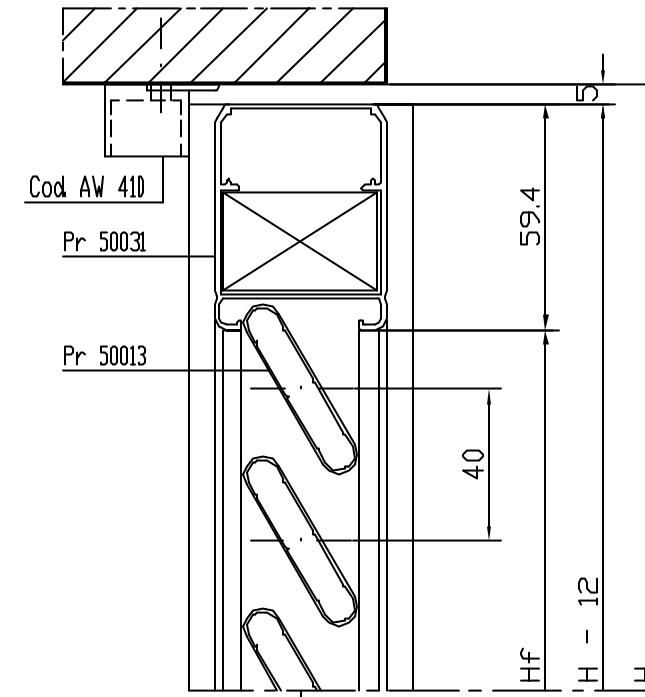

PARTICOLARE FRANCESINA

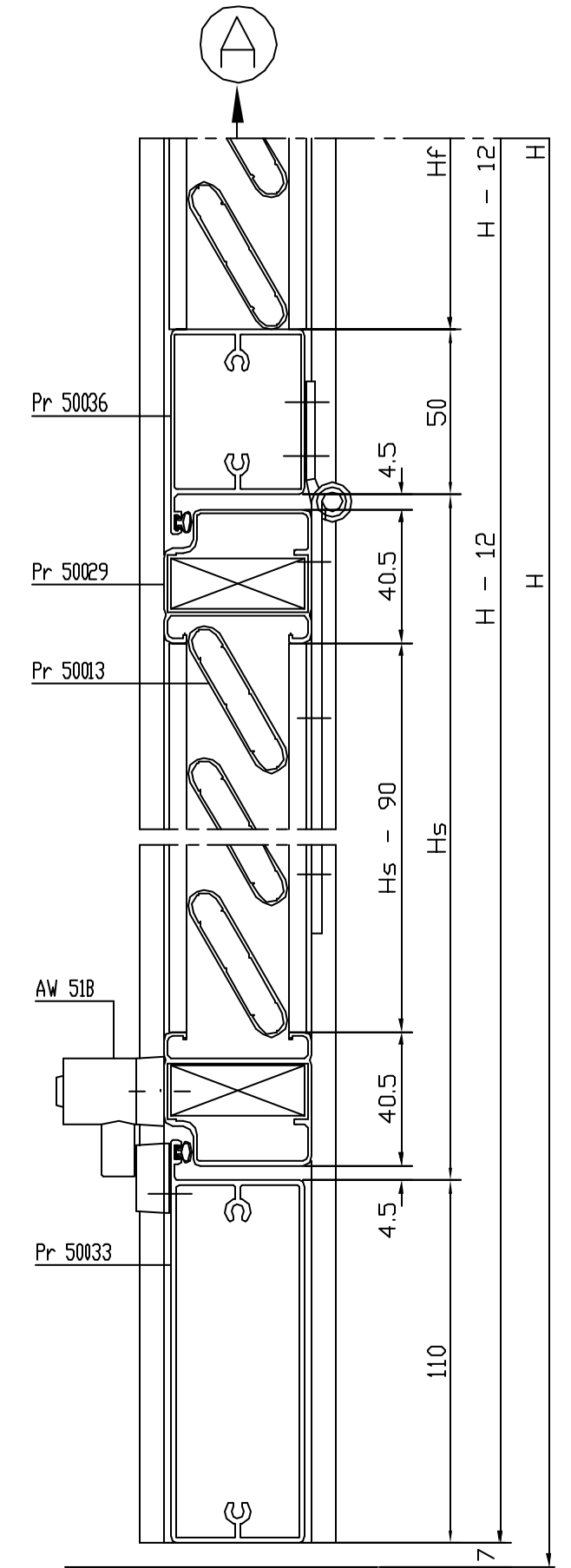
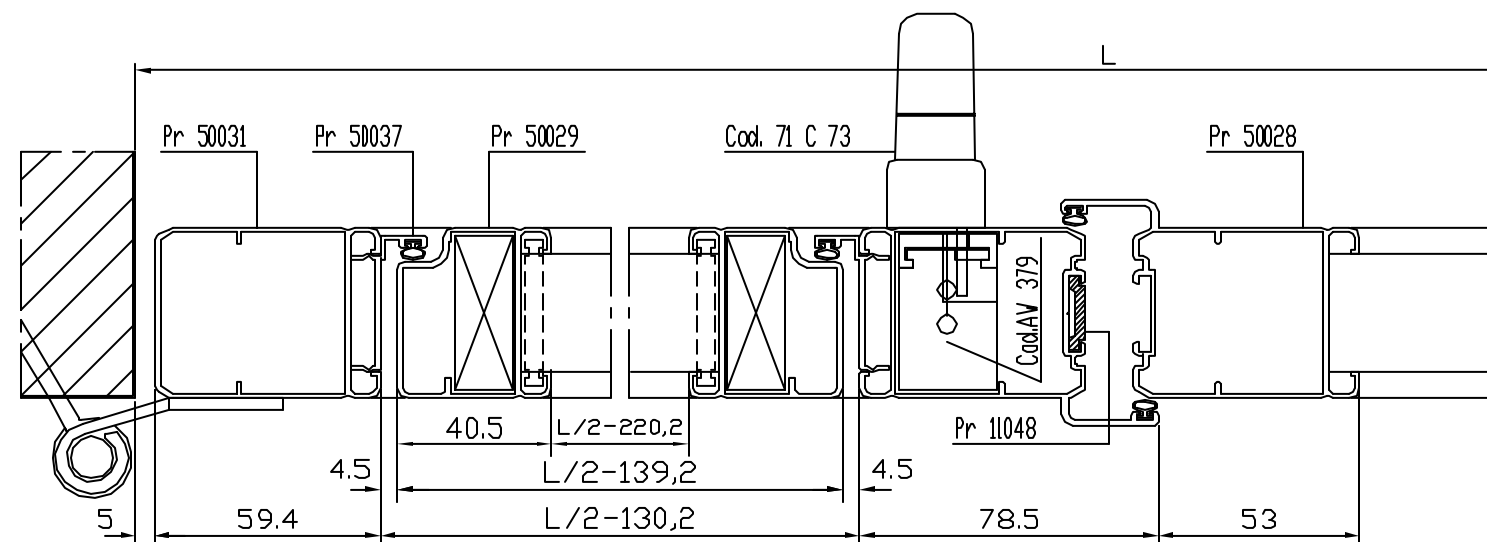

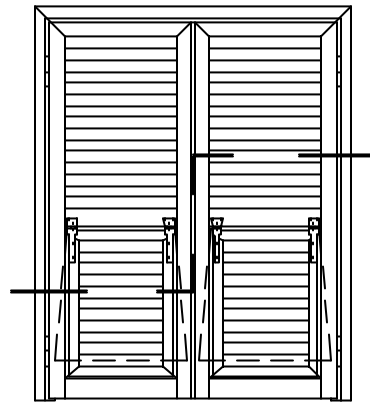

PERSIANA FINESTRA A 2 ANTE

PROFILI PERSIANA FINESTRA A 2 ANTE

Nr. Pezzi	Pr	Descrizione	Taglio
2	50025	Montante telaio	H+28
1	50025	Traverso telaio	L+56
4	50026	Montante anta	H-39,3
2	50026	Traverso superiore anta	L/2-23
4	50036	Traverso	L/2-169
4	50029	Montante sportello	Hs-9
4	50029	Traverso sportello	L/2-178
4	50037	Battuta verticale sportello	Hs
1	11048	Astina	H

OVALINE

Nr. Pezzi	Pr	Descrizione	Taglio
$\frac{Hf}{40} \times 2$	50013	Ovalino da 50mm. per sportello	L/2-243
$\frac{Hs-90}{40} \times 2$	50013	Ovalino da 50mm. per fisso superiore	L/2-153

GUARNIZIONI

Codici	Descrizione	Taglio
90 G 26	Guarnizione di battuta	6 H + 2L
90 G 26	Guarnizione di battuta per sportello	4 Hs + 2L

ACCESSORI

Nr. Pezzi	Codici	Descrizione
4	AW 204	Squadretta per Pr 50026
10	AW 203	Squadretta per Pr 50025-50029
4	30 B 50	Cerniera reversibile
1	40 C 02	Kit di collegamento
2	40 C 03	Perno di collegamento
1	71 C 73	Cremonese per aperture esterne
2	71 II 21	Terminale per asta di chiusura
4	AW 160	Cerniera in laniera per sportello
2	AW 518	Chiacciolo per sportello
2	AW 050	Braccetta per sportello
8	AW 302	Giunta per fasce (FOX)
1 Coppia	AW 421	Tappo per incontro centrale
4	AW 403	Tappo chiavi tubalarita' Pr 50026
1	AW 410	Battuta a cilindro in nylon

ACCESSORI OVALINE

Nr. Pezzi	Codici	Descrizione
$\frac{Hf}{40} \times 4$	AW 101	Sella reversibile parte fissa
$\frac{Hs-90}{40} \times 4$	AW 101	Sella reversibile sportello
16	AW 301	Sella reversibile con spessore

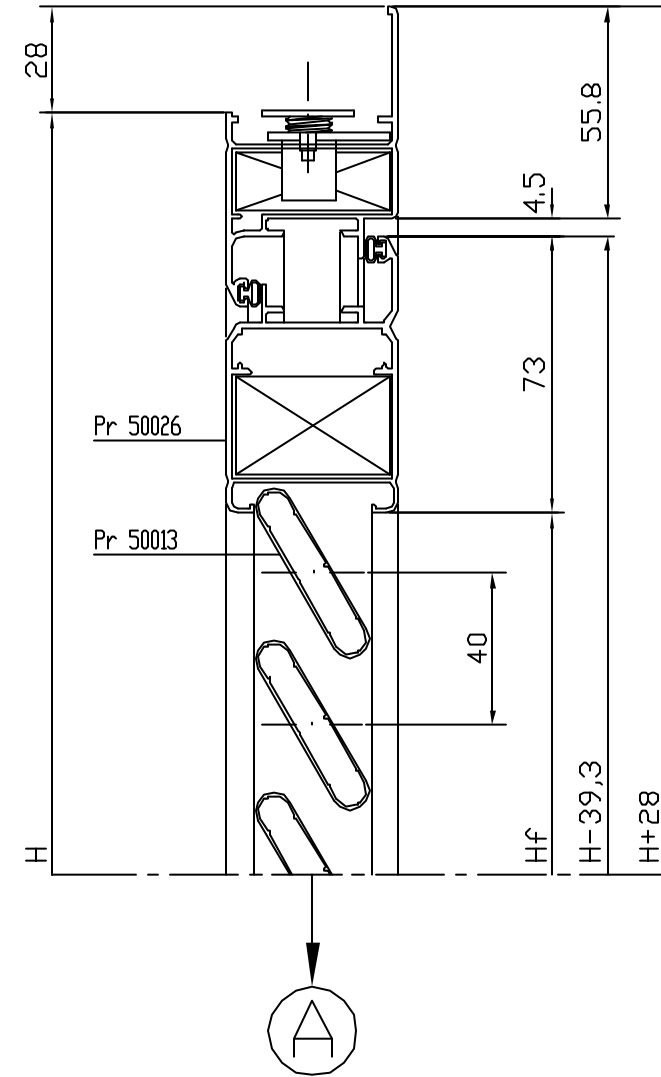

PER LA VERSIONE A TRE ANTE VEDI PAG. C 07

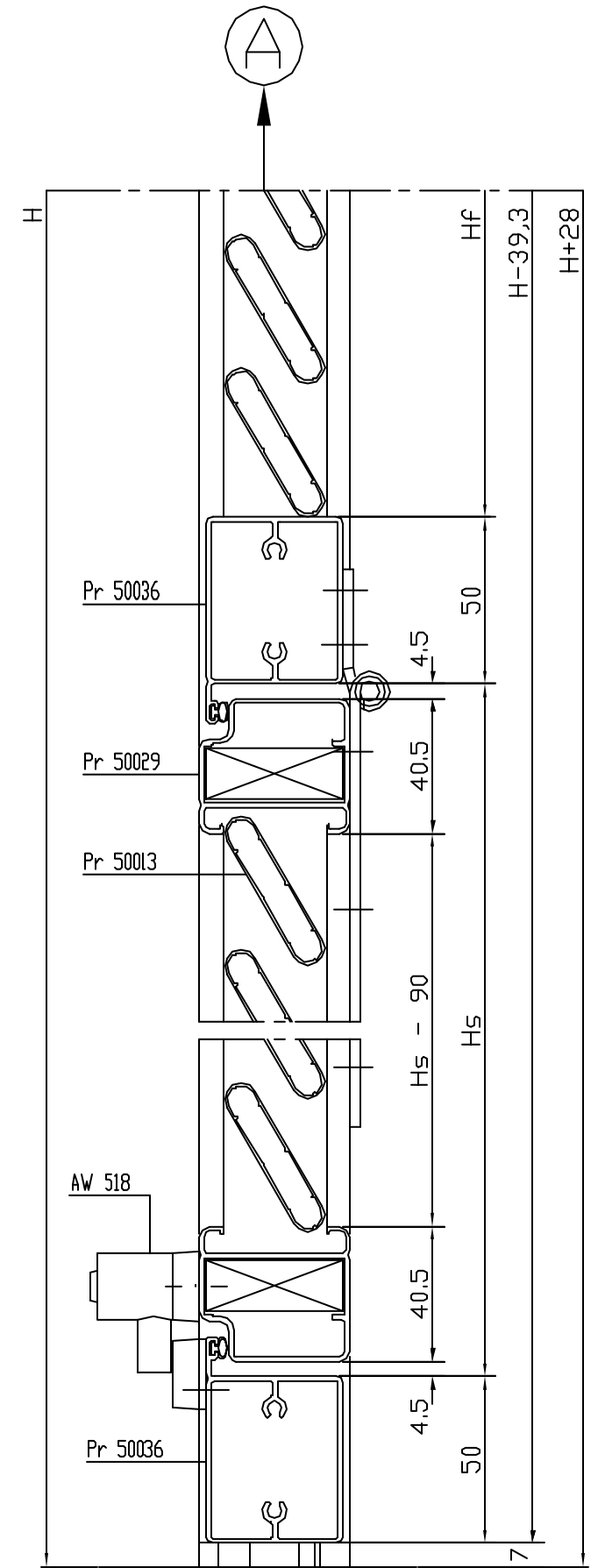
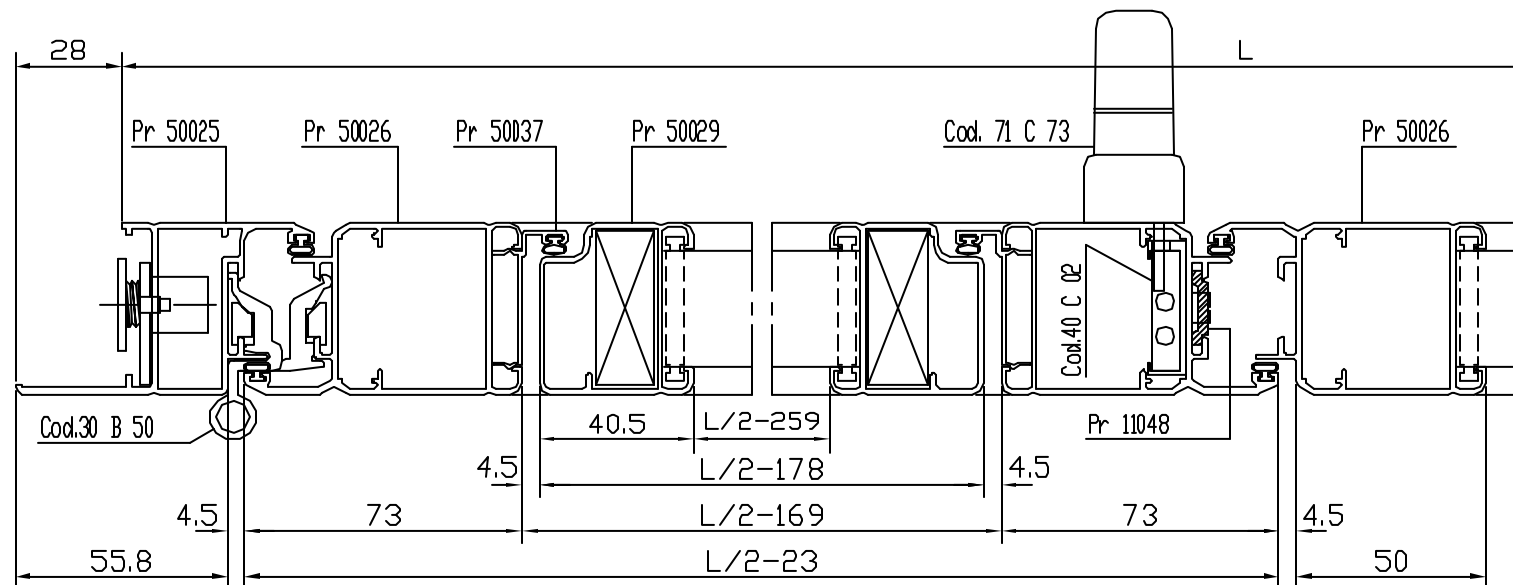

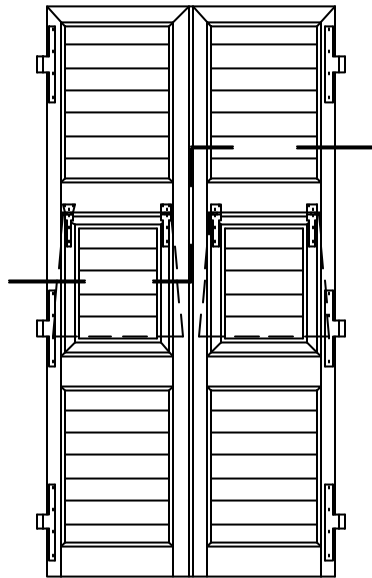

PERSIANA PORTA
A 2 ANTE

PROFILI

Nr. Pezzi	Pr	Descrizione	Taglia
2	50031	Montante a muro	H-12
2	50031	Traverso a muro superiore	L/2-11,4
2	50028	Montante centrale anta	H+7
6	50032	Traverso intermedio e Zoccolo	L/2-130,2
4	50029	Montante sportello	Hs-9
4	50029	Traverso sportello	L/2-139,2
4	50037	Battuta verticale sportello	Hs+16
4	50037	Battuta orizzontale sportello	L/2-114,2
4	50017	Montante porta selle fisso sup.	Hfs+29,4
4	50017	Montante porta selle fisso inf.	Hfi+29,4
8	50034	Traverso terminale a scatto	L/2-119,8
4	50017	Montante porta selle sportello	Hs-79,6
4	50034	Traverso termina scatto sportello	L/2-209,8
1	11048	Astina	H

OVALINE

Nr. Pezzi	Pr	Descrizione	Taglia
$\frac{Hf}{54} \times 2$	50016	Ovalina da 50mm. per sportello	L/2-223,2
$\frac{Hs-90}{54} \times 2$	50016	Ovalina da 50mm. per fisso supe inf.	L/2-133,2

GUARNIZIONI

Codici	Descrizione	Taglia
90 G 26	Guarnizione di battuta	2 H
90 G 26	Guarnizione di battuta per sportello	4 Hs + 2L

ACCESSORI OVALINE

Nr. Pezzi	Codici	Descrizione
$\frac{Hs-109}{54} \times 2$	AV 106	Sella reversibile sportello
$\frac{Hfs+Hfi}{54} \times 2$	AV 106	Sella reversibile parte fissa

ACCESSORI

Nr. Pezzi	Codici	Descrizione
4	AW 204	Squadretta per Pr 50031
8	AW 203	Squadretta per Pr 50029
6	AW 070	Cardine a murare
6	AW 100	Cantonale con occhiello piano
1	71 C 73	Cremone per aperture esterne
1	AW 379	Kit di collegamento
4	AW 160	Cerniera in lamiera per sportello
2	AW 518	CNacciola per sportello
2	AV 050	Braccetta per sportello
24	AW 401	Giunto per traverso Pr 50032
4	AW 403	Tappo chiavi tubolarita' Pr 50031-50028
1	AW 190	Battente a 'z'

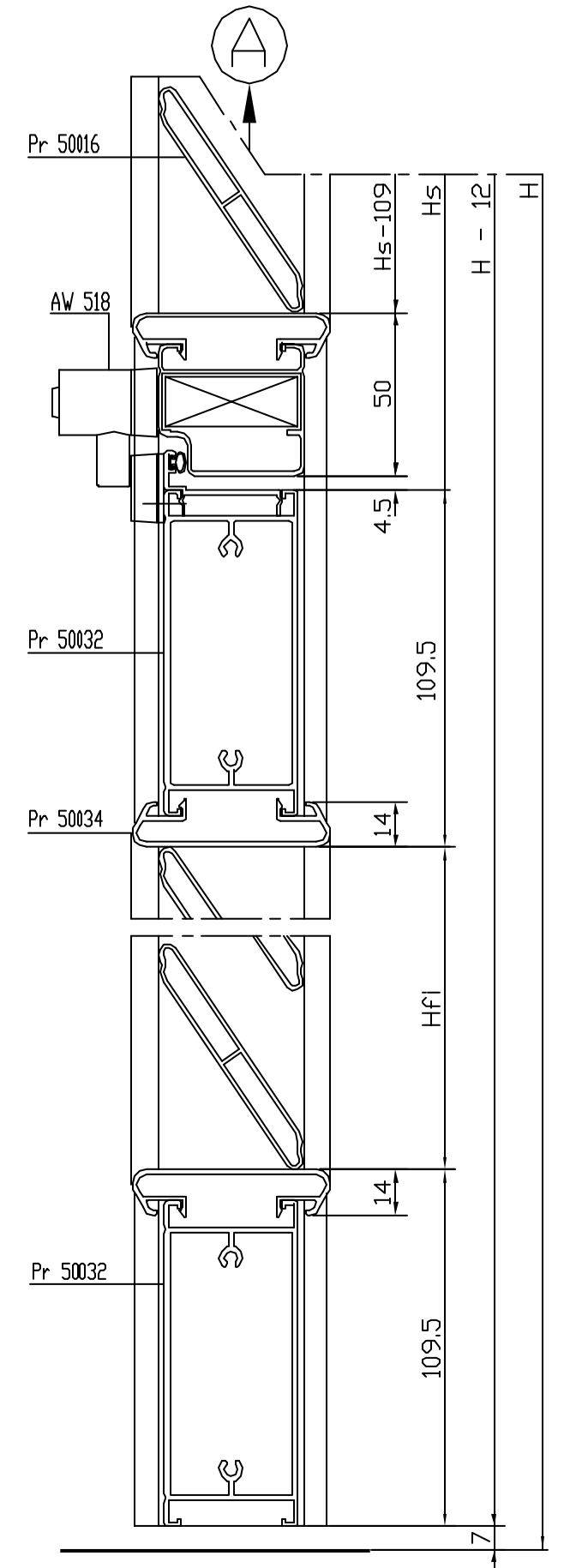
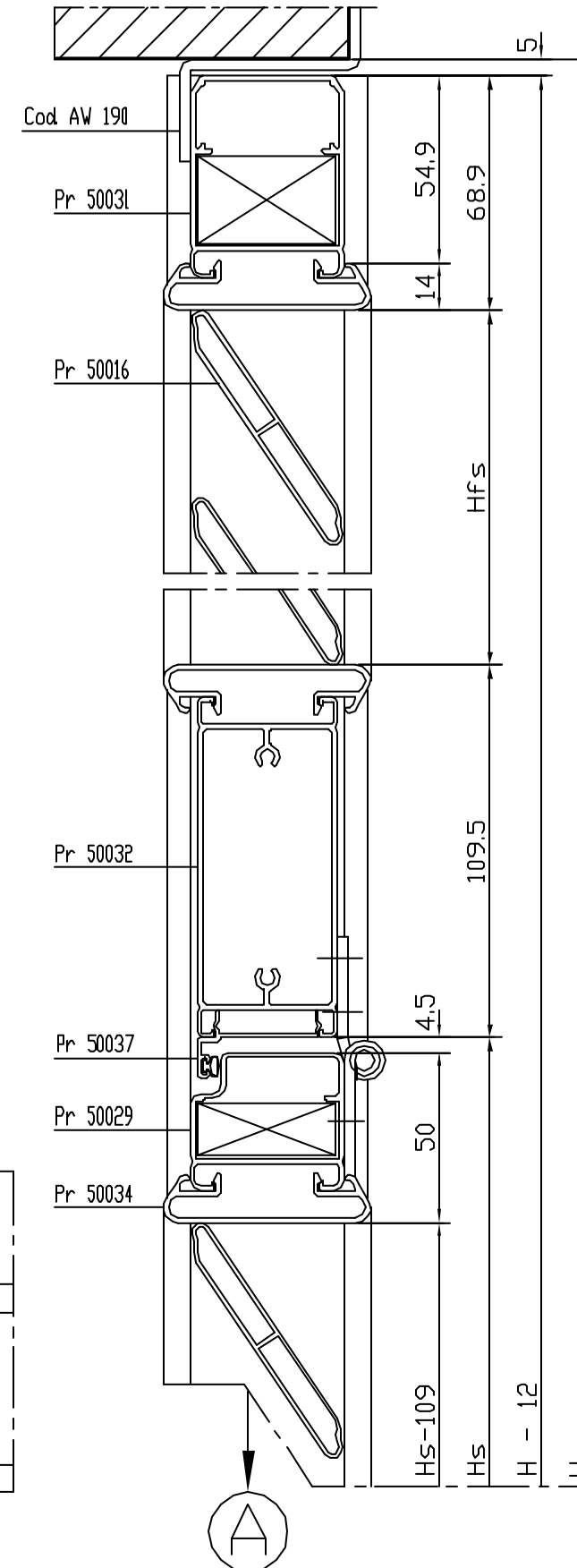
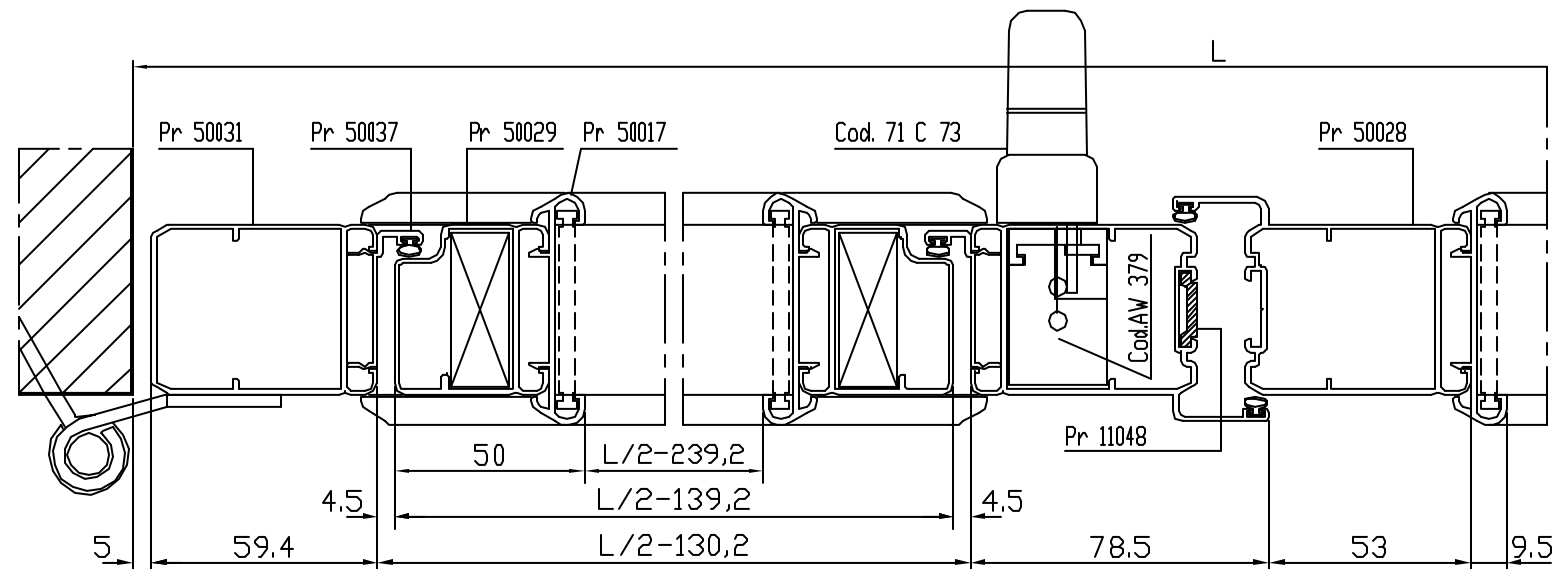

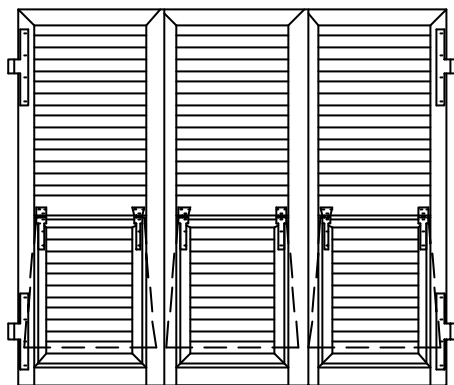

PERSIANA A 3 ANTE

PROFILI

Nr. Pezzi	Pr	Descrizione	Taglio
2	50030	Montante a muro	H-12
3	50030	Traverso a muro superiore	L/3-21,7
4	50026	Montante centrale	H+11
6	50036	Traverso intermedio e inferiore	L/3-121,7
6	50029	Montante sportello	H5-9
6	50029	Traverso sportello	L/3-130,7
6	50037	Battuta verticale sportello	H5
1	1104B	Astina	H

OVALINE

Nr. Pezzi	Pr	Descrizione	Taglio
$\frac{Hf}{40} \times 3$	50013	Ovalina da 50mm. per sportello	L/3-195,7
$\frac{Hs-90}{40} \times 3$	50013	Ovalina da 50mm. per fisso superiore	L/3-105,7

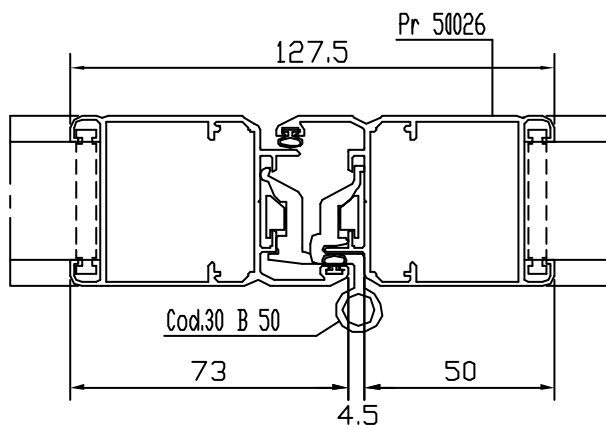

NODO PERSIANA A 3 ANTE

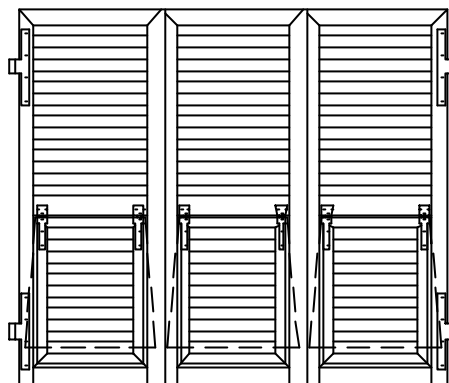

PERSIANA A 3 ANTE

PROFILI

Nr. Pezzi	Pr	Descrizione	Taglio
2	50031	Mantante a muro	H-12
3	50031	Traverso a muro superiore	L/3-11,8
4	50028	Mantante centrale	H+11
3	50036	Traverso	L/3-130,6
3	50033	Zaccolo	L/3-130,6
6	50029	Mantante sportello	Hs-9
6	50029	Traverso sportello	L/3-139,6
6	50037	Battuta verticale sportello	Hs
1	11048	Astina	H

OVALINE

Nr. Pezzi	Pr	Descrizione	Taglio
$\frac{Hf}{40} \times 3$	50013	Ovalina da 50mm. per sportello	L/3-204,6
$\frac{Hs-90}{40} \times 3$	50013	Ovalina da 50mm. per fisso superiore	L/3-114,6

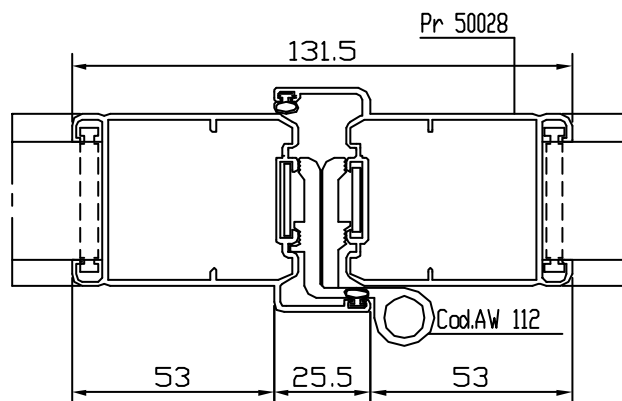

NODO PERSIANA A 3 ANTE

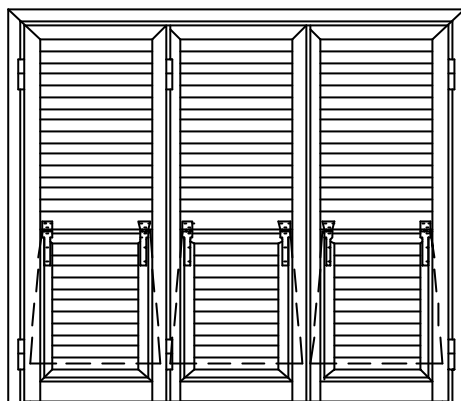

PERSIANA A 3 ANTE

PROFILI

Nr. Pezzi	Pr	Descrizione	Taglio
2	50025	Montante telaio	H+28
1	50025	Traverso telaio	L+56
6	50026	Montante anta	H-39,3
3	50026	Traverso superiore anta	L/3-9,2
6	50036	Traverso	L/3-155,2
6	50029	Montante sportello	Hs-9
6	50029	Traverso sportello	L/3-164,2
6	50037	Battuta verticale sportello	Hs
1	11048	Astina	H

DVALINE

Nr. Pezzi	Pr	Descrizione	Taglio
$\frac{Hf}{40} \times 3$	50013	Dvalino da 50mm. per sportello	L/2-229,2
$\frac{Hs-90}{40} \times 3$	50013	Dvalino da 50mm. per fisso superiore	L/2-139,2

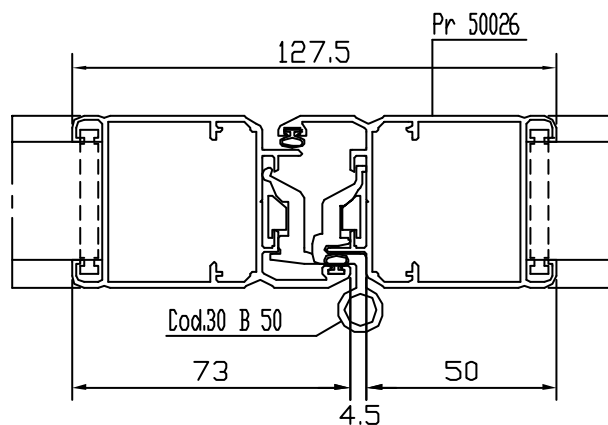

NODO PERSIANA A 3 ANTE

Nodo Laterale

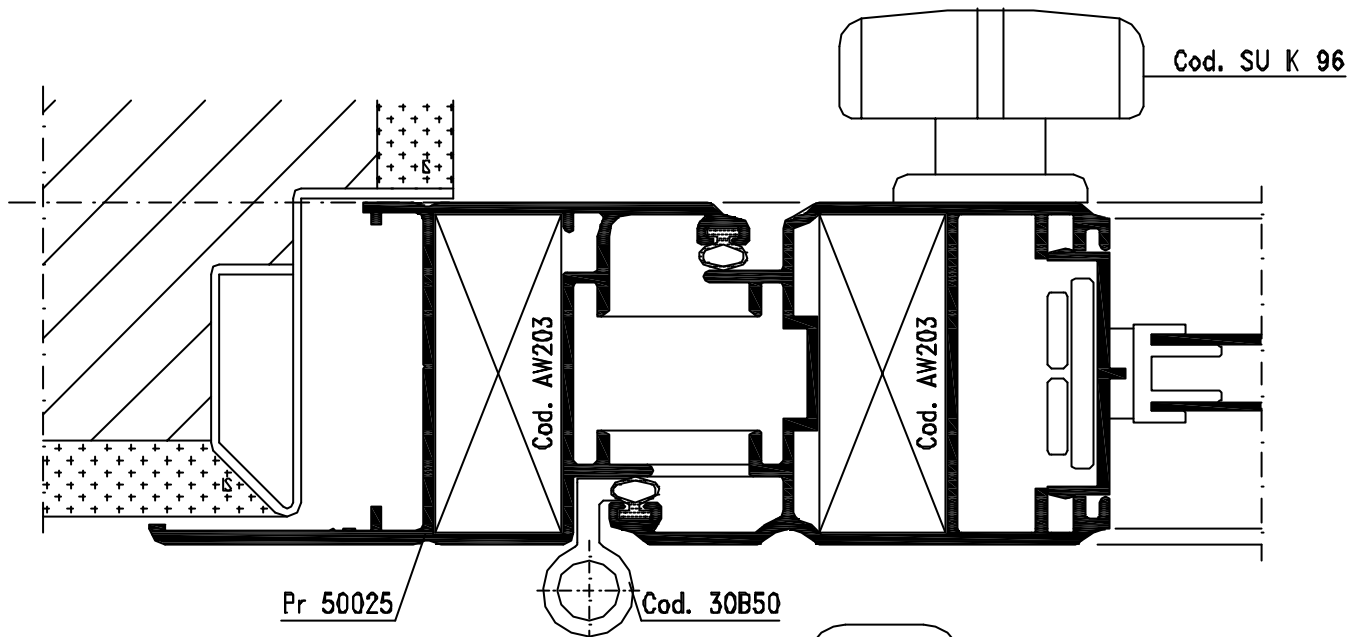

Nodo Centrale

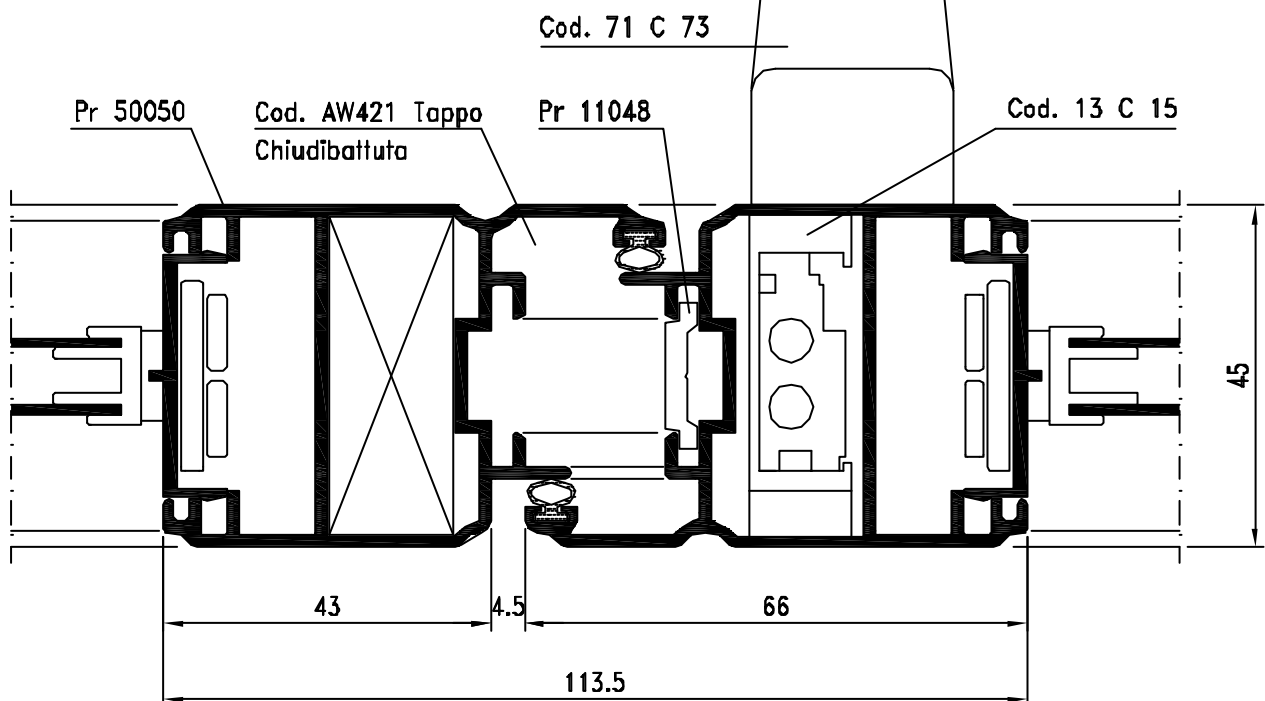

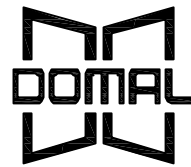

N.B.: Per Kit orientabili consultare Sunny P60.

DOMAL SUNNY XXXMIGLIA



INDICE SUNNY XXMIGLIA

DESCRIZIONE	da pag.	a pag.
INDICE		269
ACCESSORI	271	279
SAGOMARIO PROFILATI	281	282
PROFILATI 1:1	283	285
SCHEMI E DISTINTE	287	292
SEZIONI 1:1		293
LAVORAZIONI	294	296

ACCESSORI	CODICE	COLORE	DESCRIZIONE	MATER.	CONFEZ.
	AW 050	GREZZO RAL1004K RAL6005K RAL7001K RAL8014 RAL9005 RAL9010	BRACCETTO PER SPORTELLO ALLA GENOVESE	ALLUMINIO	PEZZI 200
	AW 070	GREZZO RAL1004K RAL6005K RAL7001K RAL8014 RAL9005 RAL9010	CARDINE A MURARE	ACCIAIO	PEZZI 50
	AW 100	GREZZO RAL1004K RAL6005K RAL7001K RAL8014 RAL9005 RAL9010	CANTONALE CON OCCHIELLO PIANO	ALLUMINIO	PEZZI 50
	AW 160	GREZZO RAL1004K RAL6005K RAL7001K RAL8014 RAL9005 RAL9010	CERNIERA IN LAMIERA PER SPORTELLO GENOVESE	ALLUMINIO	PEZZI 100
	AW 400	NERO	ESPANSORE PERSIANA (CON RED) Pr 50100 E Pr 50101	NYLON	PEZZI 200
	AW 410	NERO	BATTUTA CILINDRO IN NYLON	NYLON	PEZZI 100
	AW 425	NERO	INCONTRO PER ASTA E TERZA CHIUSURA	NYLON ACCIAIO	PEZZI 50
	AW 501	GREZZO	SQUADRETTA PER TELAIO	ALLUMINIO	PEZZI 250

ACCESSORI	CODICE	COLORE	DESCRIZIONE	MATER.	CONFEZ.
	AW 502	GREZZO	SQUADRETTA PER ANTE	ALLUMINIO	PEZZI 250
	AW 503	GREZZO	SQUADRETTA PER SPORTELLO Pr 50104	ALLUMINIO	PEZZI 250
	AW 504	NERO	TAPPO CHIUDI TUBOLARITA' PER Pr 50102 E Pr 50103	NYLON	PEZZI 200
	AW 505	GREZZO	KIT DI COLLEGAMENTO E FISSAGGIO CREMONESE	NYLON ALLUMINIO	PEZZI 22
	AW 506	RAL1013 RAL6005K RAL8014 RAL9005 RAL9010	SELLA REVERSIBILE PER OVALINA Pr 50013	NYLON	PEZZI 1000
	AW 507	NERO	FOX PER Pr 50106 E Pr 50107	NYLON	PEZZI 200
	AW 508	NERO	TAPPO DI COLLEGAMENTO PER PROFILO FRANCESINA Pr 50105	NYLON	PEZZI 100
	AW 509	GREZZO	CERNIERA TELAIO - ANTA BATTENTE	ALLUMINIO	PEZZI 50



ACCESSORI	CODICE	COLORE	DESCRIZIONE	MATER.	CONFEZ.
	AW 510	GREZZO RAL6005 RAL8014 RAL8017 RAL9005 RAL9010	CERNIERA PER SOLUZIONE A LIBRO	ALLUMINIO	PEZZI 50
	AW 515	NERO	GIUNTO LAV. SPORTELO Pr 50106 E Pr 50107	NYLON	PEZZI 200
	AW 518	NERO	CHIOCCIOLA PER SPORTELO ALLA GENOVESE	NYLON	PEZZI 2
	AW 530	GREZZO RAL1004K RAL6005K RAL7001K RAL8014 RAL9005 RAL9010	BATTENTE A "Z" PER Pr 50103	ALLUMINIO	PEZZI 100
	AW 580	GREZZO RAL1004K RAL6005K RAL7001K RAL8014 RAL9005 RAL9010	STECCA PRETRANCIATA PER OVALINA 40x8x1	ALLUMINIO	PEZZI 50
	AW 650	GREZZO RAL1004K RAL6005K RAL7001K RAL8014 RAL9005 RAL9010	CERNIERA/CARDINE REGOLABILE	ALLUMINIO	PEZZI 50
	AW 651	GREZZO RAL1004K RAL6005K RAL7001K RAL8014 RAL9005 RAL9010	CANTONALE \varnothing 12 mm	ALLUMINIO	PEZZI 50
	AW 652	GREZZO RAL1004K RAL6005K RAL7001K RAL8014 RAL9005 RAL9010	CANTONALE \varnothing 14 mm	ALLUMINIO	COPPIA 50

ACCESSORI	CODICE	COLORE	DESCRIZIONE	MATER.	CONFEZ.
	AW 653	GREZZO RAL1004K RAL6005K RAL7001K RAL8014 RAL9005 RAL9010	CANTONALE \varnothing 16 mm	ALLUMINIO	COPPIA 50
	30 D 44	NERO	FERMO IMPOSTA AUTOMATICO GRILLO	NYLON	PEZZI 10
	30 D 48	NERO	FERMO IMPOSTA AUTOMATICO GRILLO TOP, CON AMMORTIZZATORE	NYLON	PEZZI 10
	40 C 03	GREZZO	PERNO DI COLLEGAMENTO TRA KIT + ASTINA + CREMONESE PER APERTURE ESTERNE	ACCIAIO	PEZZI 200
	60 C 50	RAL1013 RAL6005 RAL8017 RAL9005 RAL9010	CREMONESE "MANON" CON CHIAVE PER APERTURE ESTERNE	PRESSO- FUSO	PEZZI 10
	71 C 73	VER.NAT. RAL1013 RAL6005 RAL8017 RAL9005 RAL9010	CREMONESE IN ALLUMINIO "MAXIMA" PER APERTURE ESTERNE	ZAMA	PEZZI 10











ACCESSORI	CODICE	COLORE	DESCRIZIONE	MATER.	CONFEZ.
	33B095	RAL9005	CARDINE 85mm REGOLABILE FISSAGGIO A TASSELLO	ACCIAIO	PEZZI 20
	33B096	RAL9005	CARDINE 125mm REGOLABILE FISSAGGIO A TASSELLO	ACCIAIO	PEZZI 20
	33B097	RAL9005	CARDINE 145mm REGOLABILE FISSAGGIO A TASSELLO	ACCIAIO	PEZZI 20
	33B098	RAL9005	CARDINE 175mm REGOLABILE FISSAGGIO A TASSELLO	ACCIAIO	PEZZI 20
	33C100	RAL9005	CONFEZIONE BASE SPAGNOLETTA PICCOLA 2 ANTE	ZAMA	PEZZI 20
	33C101	RAL9005	CONFEZIONE BASE SPAGNOLETTA PICCOLA 1 ANTA	ZAMA	PEZZI 20
	33C102	RAL9005	CONFEZIONE BASE SPAGNOLETTA A SCATTO	ZAMA	PEZZI 20
	33C103	RAL9005	PERNO DI CHIUSURA DIRITTO	ZAMA	PEZZI 50





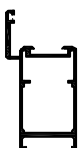

ACCESSORI	CODICE	COLORE	DESCRIZIONE	MATER.	CONFEZ.
	33C104	RAL9005	PIASTRA DI CHIUSURA AD ANGOLO	ACCIAIO	PEZZI 20
	33C105	RAL9005	GUIDA ASTE	ZAMA	PEZZI 50
	33C106	RAL9005	CHIUSURA VERTICALE AD ESPANSIONE DX. CONFEZIONE BASE	ZAMA/ACC.	PEZZI 20
	33C107	RAL9005	CHIUSURA VERTICALE AD ESPANSIONE SX. CONFEZIONE BASE	ZAMA/ACC.	PEZZI 20
	33C108	RAL9005	COMPENSATORE DI ROTAZIONE 180° DX. PER Cod. 33C106	ZAMA	PEZZI 50
	33C109	RAL9005	COMPENSATORE DI ROTAZIONE 180° SX. PER Cod. 33C107	ZAMA	PEZZI 50
	33C110	RAL9005	POZZETTO PER SOGLIA	ZAMA	PEZZI 50
	33C116	RAL9005	ASTA DI CHIUSURA 1800mm	ACCIAIO	PEZZI 10

ACCESSORI	CODICE	COLORE	DESCRIZIONE	MATER.	CONFEZ.
	33C117	RAL9005	ASTA DI CHIUSURA 2400mm	ACCIAIO	PEZZI 10
	33C118	RAL9005	ASTA DI CHIUSURA 3200mm	ACCIAIO	PEZZI 10
	33C130	RAL9005	PERNO DI CHIUSURA M8	ACCIAIO	PEZZI 50
	33C131	RAL9005	PERNO DI CHIUSURA Ø10 DA INCOLLARE	ACCIAIO	PEZZI 50
	33C132	RAL9005	PERNO DI CHIUSURA ECCENTRICO	ACC.-ABS	PEZZI 10
	33D100	RAL9005	ROSETTA COPRIFORO CARDINE	ABS	PEZZI 100
	33D101	GREZZO	TASSELLO 100mm	ABS	PEZZI 50
	33D102	GREZZO	TASSELLO 135mm	ABS	PEZZI 50

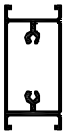
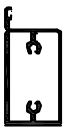
SEZIONE	CODICE	DESCRIZIONE	BOBINE m	SCATOLA m
	90 G 26	GUARNIZIONE PER BATTUTA INTERNA MATERIALE: ELAPRENE COLORE: NERO	400	800
	STG 35	GUARNIZIONE DI FINITURA SCURETTO MATERIALE: EPDM COLORE: NERO	150	150

ATTREZZATURE	CODICE	DESCRIZIONE	CONFEZ.
	30 W 70	PUNZONATRICE PER SQUADRETTE AW 501 - AW 502 AW 503	PEZZI 1

SEZIONE	CODICE	PESO Kg/m.	SUP. IN VISTA mm.	PAGINA	DESCRIZIONE
	Pr 07220	1,084	187	B03	PROFILATO DOGA mm. 23,5
	Pr 11048	0,144	14	B01	PROFILATO ASTA DI CHIUSURA
	Pr 23338	0,937	248	B03	PROFILATO DOGA
	Pr 50013	0,240	111	B02	PROFILATO OVALINA mm. 50 (ALLEGGERITA)
	Pr 50100	0,664	83	B01	PROFILATO TELAIO
	Pr 50101	0,778	110	B01	PROFILATO TELAIO
	Pr 50102	0,853	146	B01	PROFILATO ANTA SORMONTO
	Pr 50103	0,716	119	B01	PROFILATO ANTA
	Pr 50104	0,564	115	B01	PROFILATO SPORTELLO
	Pr 50105	0,481	84	B01	PROFILATO FRANCESINA H 36 mm.

SEZIONE	CODICE	PESO Kg/m.	SUP. IN VISTA mm.	PAGINA	DESCRIZIONE
	Pr 50106	0,875	144	B02	PROFILATO FASCIA H 66 mm.
	Pr 50107	0,797	140	B02	PROFILATO ZOCCOLO H 62 mm.
	Pr 50108	0,354	36	B02	PROFILATO PORTA DOGA Pr 23338
	Pr 50109	0,170	45	B02	PROFILATO BATTUTA RIPORTATA PER SPORTELLO
	Pr 50110	0,292	71	B02	PROFILATO BATTUTA RIPORTATA PER ANTA Pr 50103
	Pr 50114	0,232	89	B02	PROFILATO OVALINA mm. 40 x 8
	Pr 50115	0,267	65	B02	PROFILATO COMPENSATORE PER AW 580

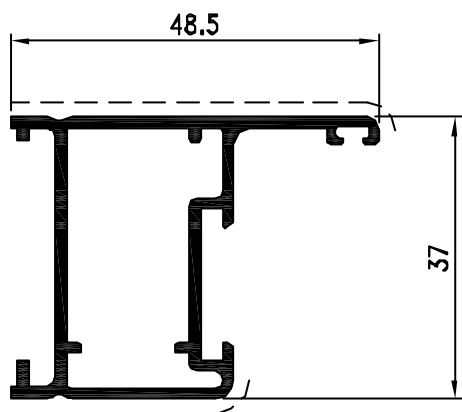

Pr. 50100 kg/m. 0.664

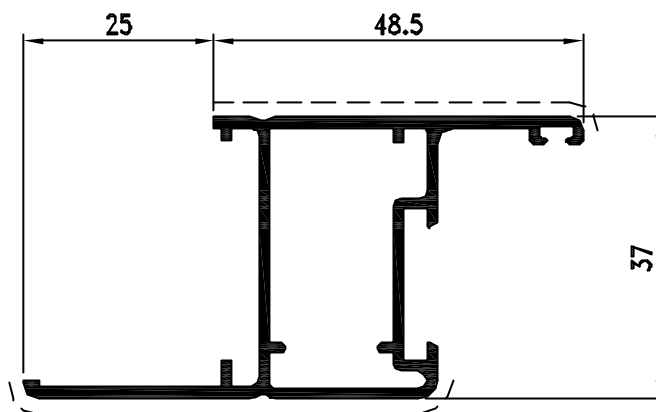

Pr. 50101 kg/m. 0.778

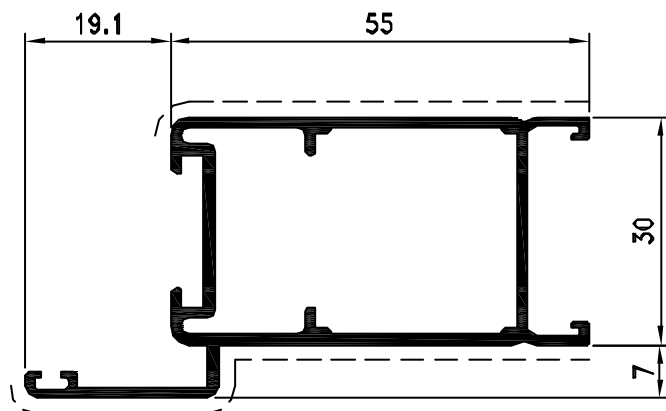

Pr. 50102 kg/m. 0.853

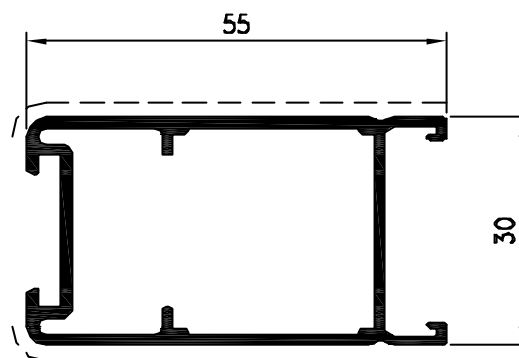

Pr. 50103 kg/m. 0.716

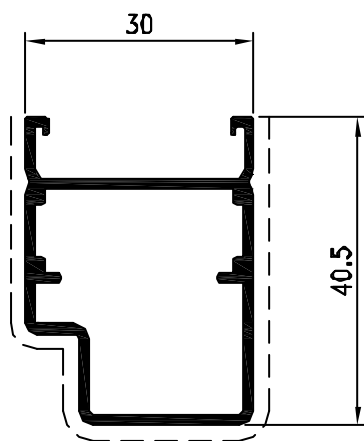

Pr. 50104 kg/m. 0.564

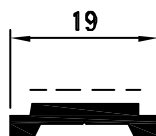

Pr. 11048 kg/m. 0.144

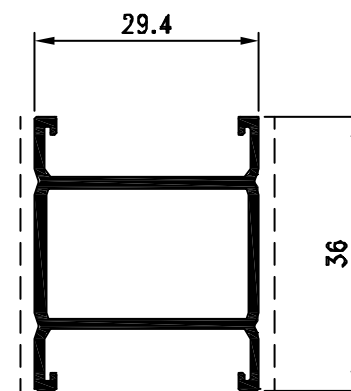

Pr. 50105 kg/m. 0.481

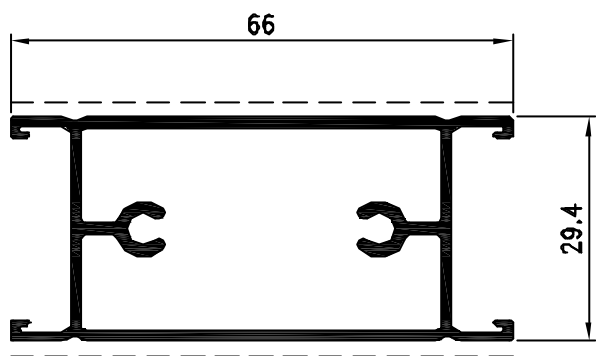

Pr. 50106 kg/m. 0.875

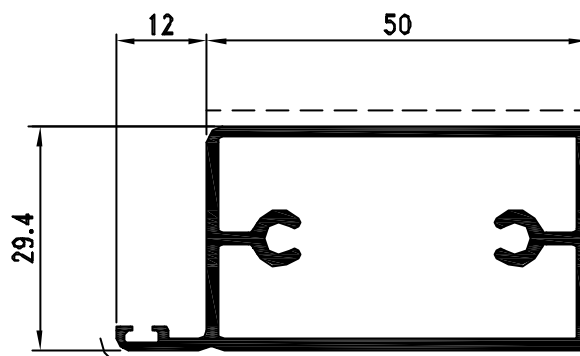

Pr. 50107 kg/m. 0.797

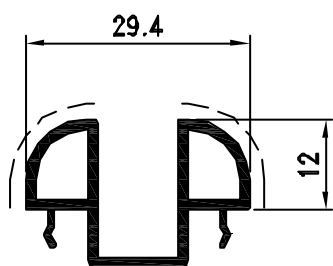

Pr. 50108 kg/m. 0.354

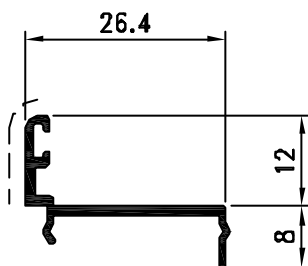

Pr. 50109 kg/m. 0.170

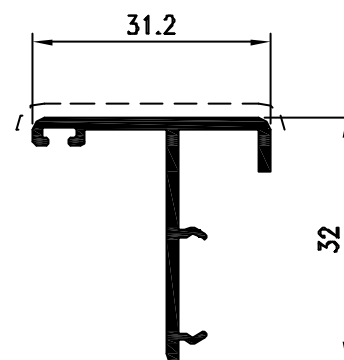

Pr. 50110 kg/m. 0.292

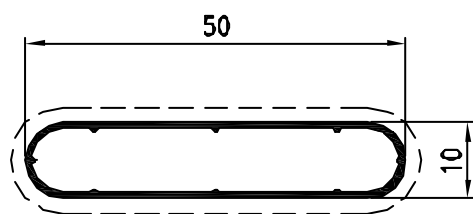

Pr. 50013 kg/m. 0.240

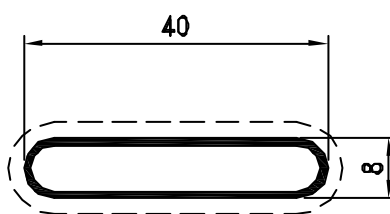

Pr. 50114 kg/m. 0.232

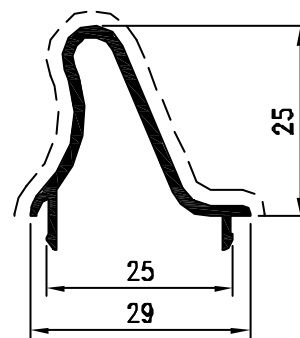

Pr. 50115 kg/m. 0.267

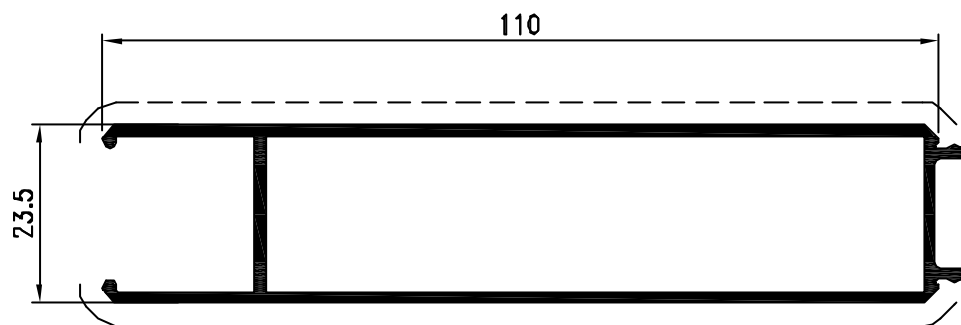

Pr. 07220 kg/m. 1.084

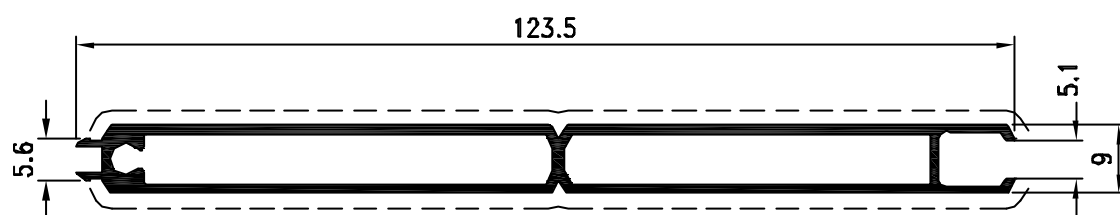

Pr. 23338 kg/m. 0.937

SCURO A 2 ANTE

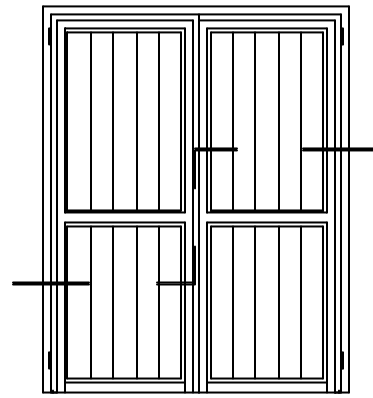

SCURO A 2 ANTE

PROFILATI

Nr. Pezzi	Pr	Descrizione	Taglio
2	50101	Mantante telaio	H+25
1	50101	Traverso telaio	L+50
4	50102	Mantante anta	H-30
2	50102	Traverso anta superiore	L/2-10,25
2	50103	Zaccato anta	L/2-158,45
2	50106	Fascia anta	L/2-158,45
4	50108	Compensatore anta verticale sup.	
4	50108	Compensatore anta verticale inf.	
8	50108	Compensatore anta orizzontale inf.	

DOGHE

Nr. Pezzi	Pr	Descrizione	Taglio
$\frac{L/2-167,15}{120} \times 2$	21658	Profilata doga per fisso superiore	(H-H inf.)-135
$\frac{L/2-167,15}{120} \times 2$	21658	Profilata doga per fisso inferiore	H inf.-117

GUARNIZIONI

Codici	Descrizione	Taglia
90 G 26	Guarnizione di battuta	6H+2L

ACCESSORI

Nr. Pezzi	Codici	Descrizione
8	AV 400	Esansore di regolazione e fissaggio
2	AV 501	Squadretta per telaio Pr 50101
4	AV 502	Squadretta per anta Pr 50102
4	AV 504	Tappa chiusi tubolarità Pr 50102
4	AV 507	Giunto per fascia (Fax) Pr 50106
1	71 C 73	Cremanese Maxima per aperture esterne
1	AV 505	Kit di collegamento
2	40 C 03	Penna di collegamento
4	AV 509	Cerniera reversibile estrusa
	STG 35	Guarnizione di finitura scuretta

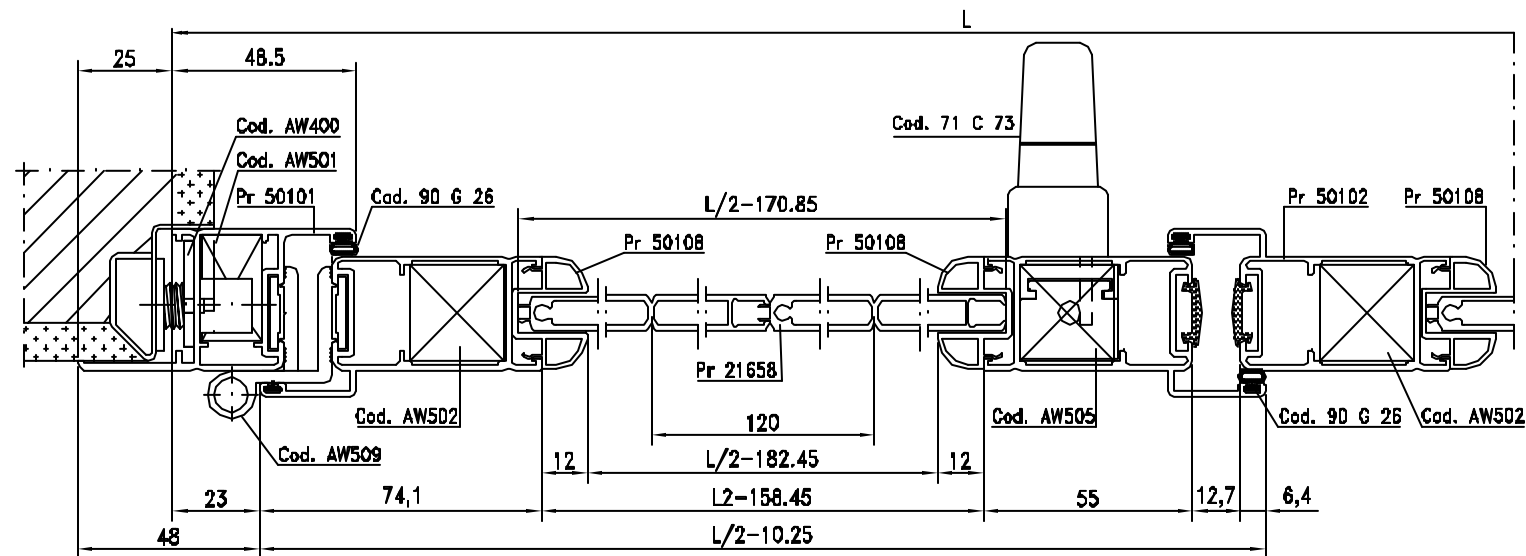
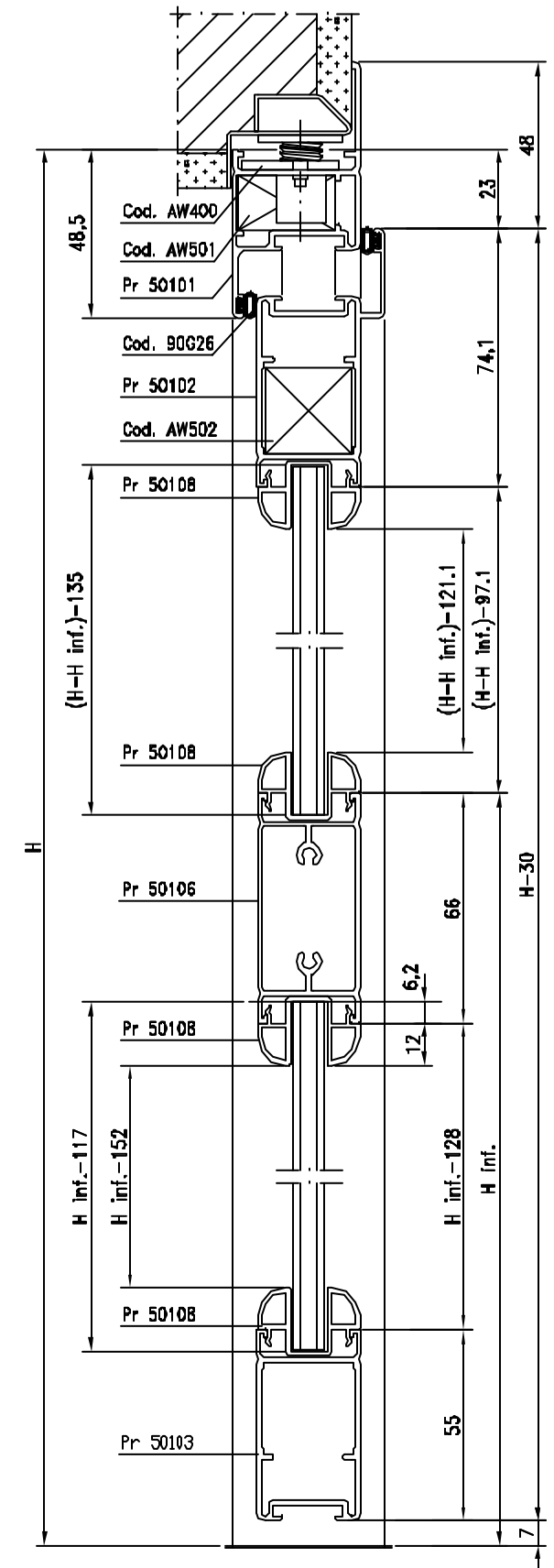

PERSIANA FINESTRA A LIBRO 4 ANTE

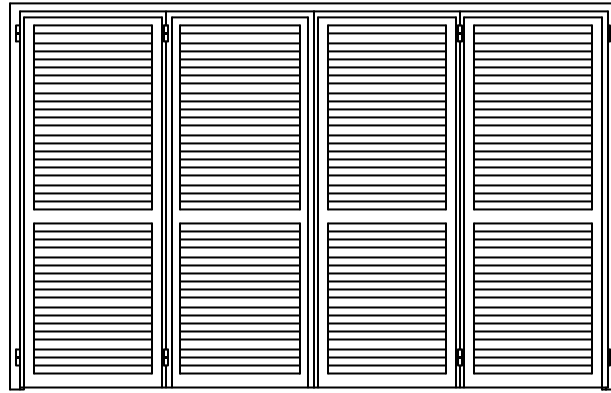

PERSIANA FINESTRA A LIBRO 4 ANTE

PROFILATI

Nr. Pezzi	Pr	Descrizione	Taglio
2	50101	Montante telaio	H+25
1	50101	Traverso telaio	L+50
8	50103	Montante anta	H-41,4
4	50103	Traverso anta superiore	L/4-23,45
4	50106	Fascia anta	L/4-133,45
4	50107	Zoccolo anta	L/4-133,45
3	50110	Battuta riportata anta	H-41,4

OVALINE

Nr. Pezzi	Pr	Descrizione	Taglio
$\frac{H \text{ inf} - 123}{44} \times 4$	50013	Ovalina da 50mm per fissa superiore	L/4-118
$\frac{H - H \text{ inf} - 89,4}{44} \times 4$	50013	Ovalina da 50mm per fissa inferiore	L/2-118

GUARNIZIONI

Codici	Descrizione	Taglio
90 G 26	Guarnizione di battuta	5H+L

ACCESSORI

Nr. Pezzi	Codici	Descrizione
8	AV 400	Espansore di regolazione e fissaggio
2	AV 501	Squadretta per telaio Pr 50101
4	AV 502	Squadretta per anta Pr 50103
4	AV 504	Tappo chiavi tubolarità Pr 50103
4	AV 507	Giunto per fascia (Fox) Pr 50106 - Pr 50107
1	71 C 73	Cremonese Maxho per aperture esterne
1	AV 505	Kit di collegamento
2	40 C 03	Perno di collegamento
8	AV 510	Cerniera reversibile estrusa

ACCESSORI OVALINE

Nr. Pezzi	Codici	Descrizione
$\frac{H \text{ inf} - 123}{44} \times 4$	AW 506	Sella distanziatore parte superiore
$\frac{H - H \text{ inf} - 89,4}{44} \times 4$	AW 506	Sella distanziatore parte inferiore

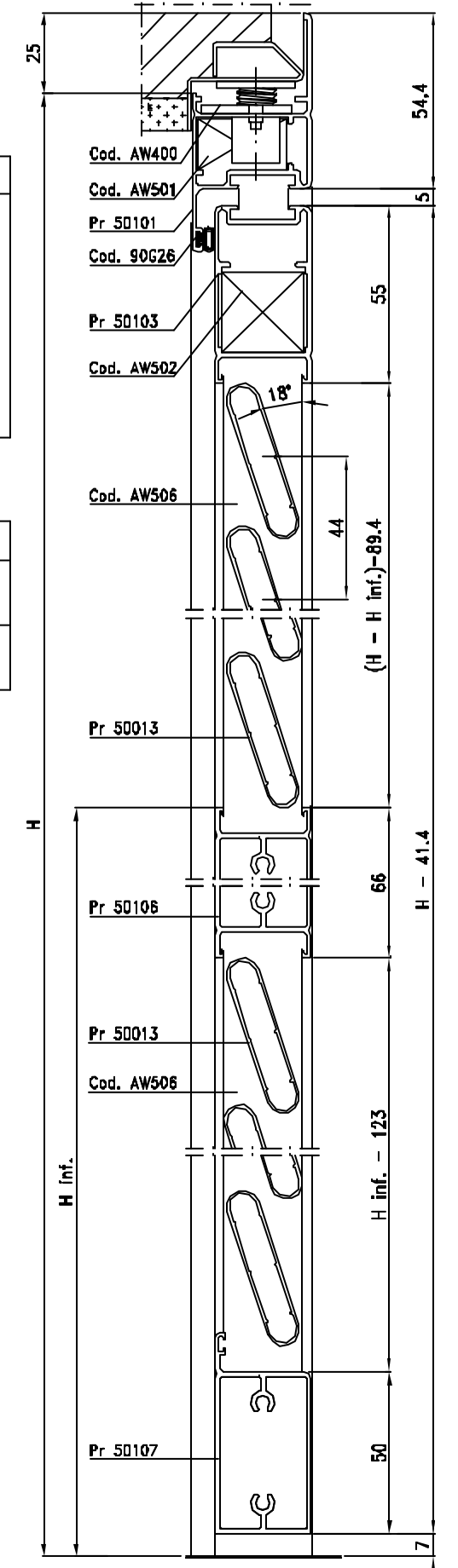
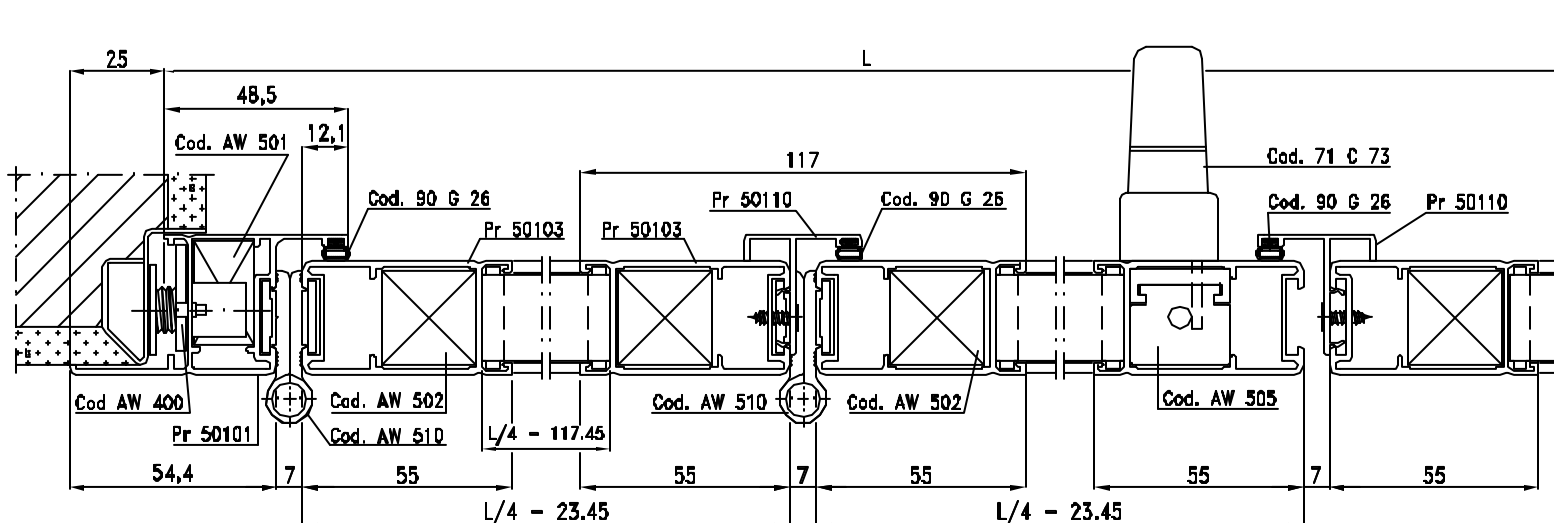

PERSIANA FINESTRA FRANCESINA A 2 ANTE

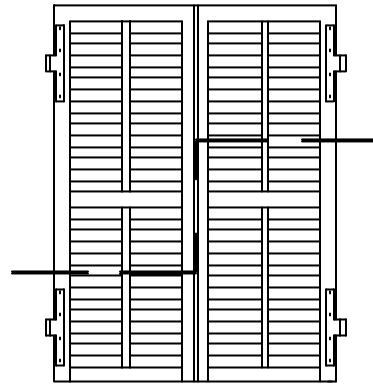

PERSIANA FINESTRA
FRANCESINA A 2 ANTE

PROFILATI

Nr. Pezzi	Pr	Descrizione	Taglio
2	50102	Mantante anta	H-12
2	50103	Mantante anta	H-12
2	50103	Traverso anta superiore	L/2-11.35
2	50105	Mantante francesina superiore	(H-Hinf.)-60
2	50105	Mantante francesina inferiore	Hnf-123
2	50106	Fascia anta	L/2-121.35
2	50107	Zaccolo anta	L/2-121.35

DVALINE

Nr. Pezzi	Pr	Descrizione	Taglio
$\frac{H \text{ inf}-123}{44} \times 2$	50013	Dvalino da 50mm. per fisso superiore	L/2-138
$\frac{(H-Hnf.)-60}{44} \times 2$	50013	Dvalino da 50mm. per fisso inferiore	L/2-138
$\frac{H \text{ inf}-123}{44} \times 4$	50013	Dvalino da 50mm. per francesina superiore	L/2-43
$\frac{(H-Hnf.)-60}{44} \times 4$	50013	Dvalino da 50mm. per francesina inferiore	L/2-43

GUARNIZIONI

Codici	Descrizione	Taglio
90 G 26	Guarnizione di battuto	2H

ACCESSORI

Nr. Pezzi	Codici	Descrizione
4	AW 070	Cordine a murare
4	AW 100	Cantonale con occhio piano
4	AW 502	Squadretta per anta Pr 50102
4	AW 504	Toppo chiusi tubolarità Pr 50102
4	AW 507	Giunto per fascia (Fox) Pr 50106 - Pr 50107
1	71 C 73	Grenonese Maxima per aperture esterne
1	AV 505	Kit di collegamento
2	40 C 03	Perno di collegamento
8	AV 508	Toppo per Pr 50105 (francesina)
	STG 35	Guarnizione di finitura scuretto

ACCESSORI DVALINE

Nr. Pezzi	Codici	Descrizione
$\frac{H \text{ inf}-123}{44} \times 2$	AW 506	Sella distanziatore parte superiore
$\frac{(H-Hnf.)-60}{44} \times 2$	AW 506	Sella distanziatore parte inferiore

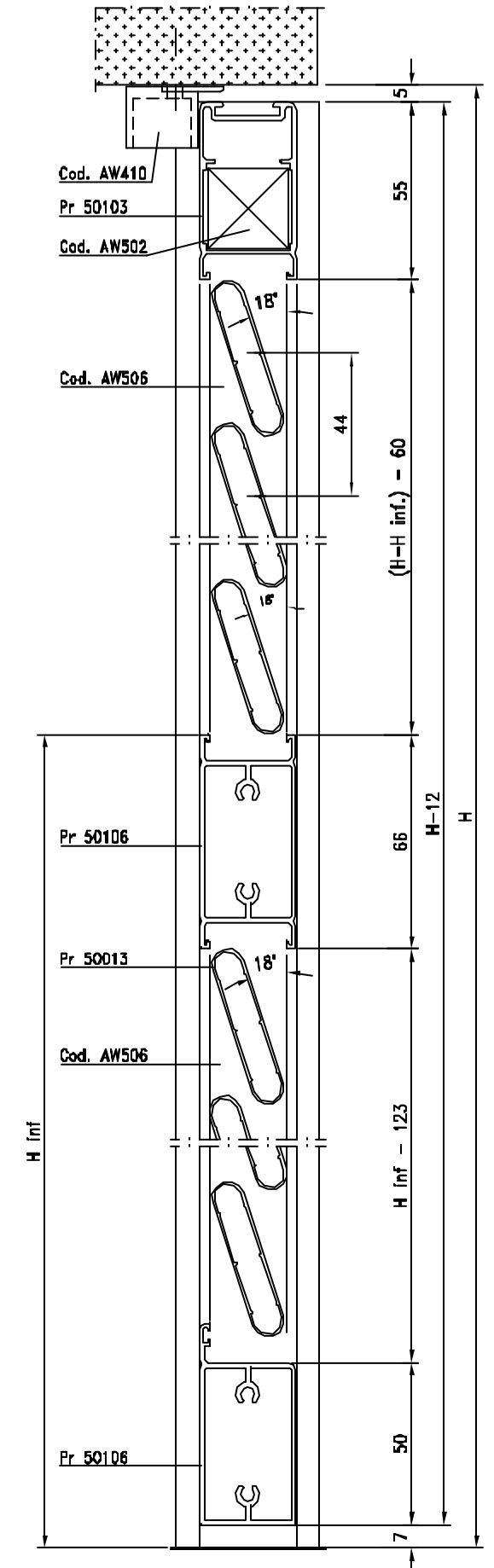
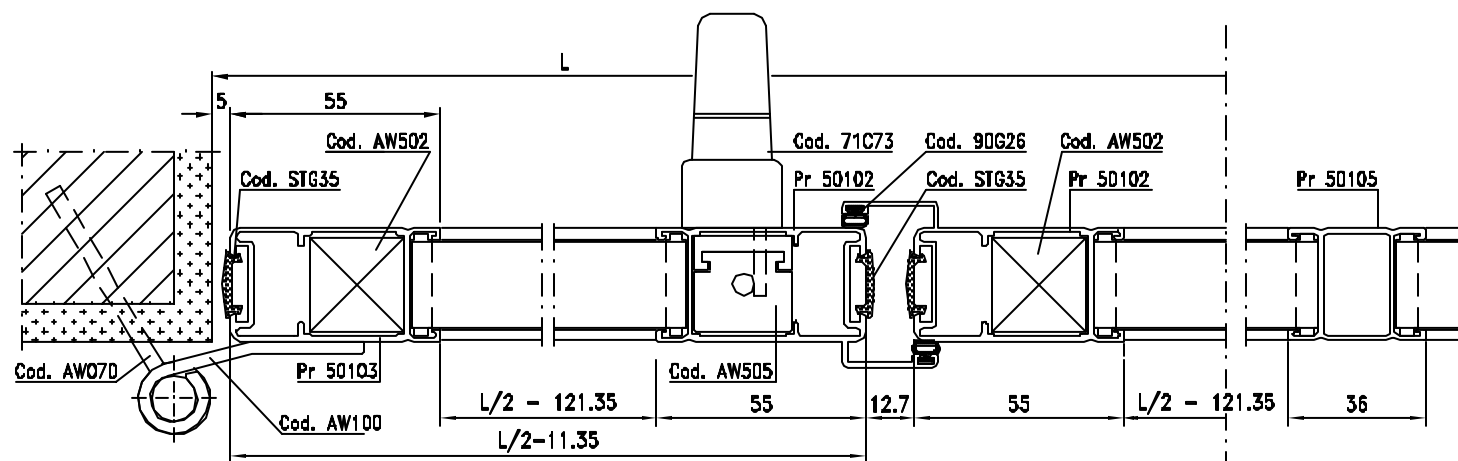

PERSIANA FINESTRA FRANCESINA A 3 ANTE

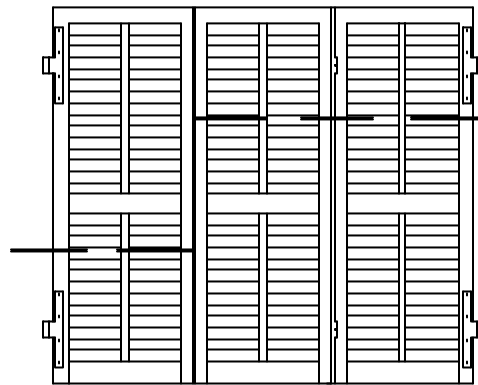

PERSIANA FINESTRA
FRANCESINA A 3 ANTE

PROFILATI

Nr. Pezzi	Pr	Descrizione	Taglia
4	50102	Montante anta	H-12
2	50103	Montante anta	H-12
3	50103	Traversa anta superiore	L/3-11.8
3	50105	Montante francesina superiore	(H-Hinf.)-60
3	50105	Montante francesina inferiore	Hinf.-123
3	50106	Fascia anta	L/3-121.8
3	50107	Zoccolo anta	L/3-121.8

OVALINE

Nr. Pezzi	Pr	Descrizione	Taglia
$\frac{H \text{ inf}-123}{44} \times 6$	50013	Ovalina da 50mm. per fisso inferiore	L/3-44
$\frac{H+Hinf.-60}{44} \times 6$	50013	Ovalina da 50mm. per fisso superiore	L/3-44

GUARNIZIONI

Codici	Descrizione	Taglio
90 G 26	Guarnizione di battuta	4H

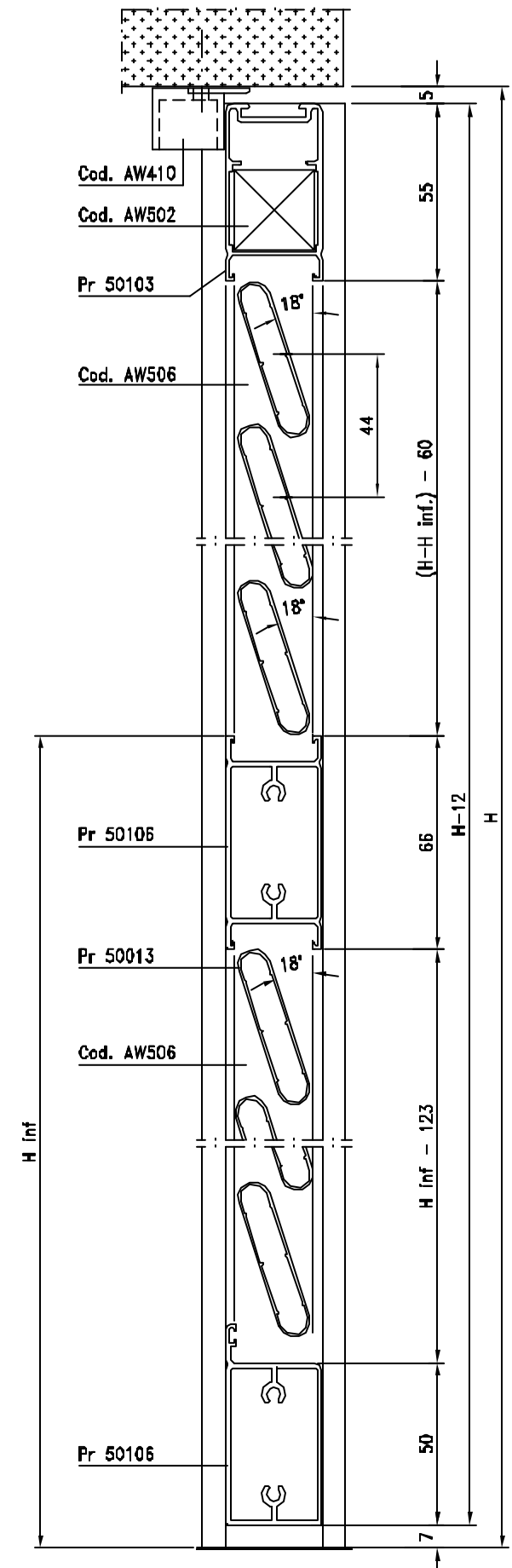
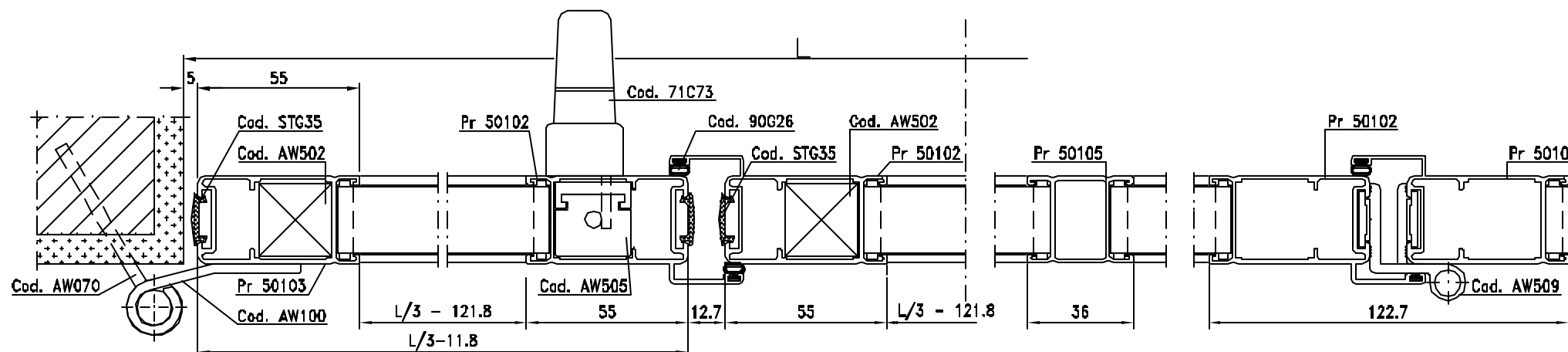

PROFILATO COMPENSATORE

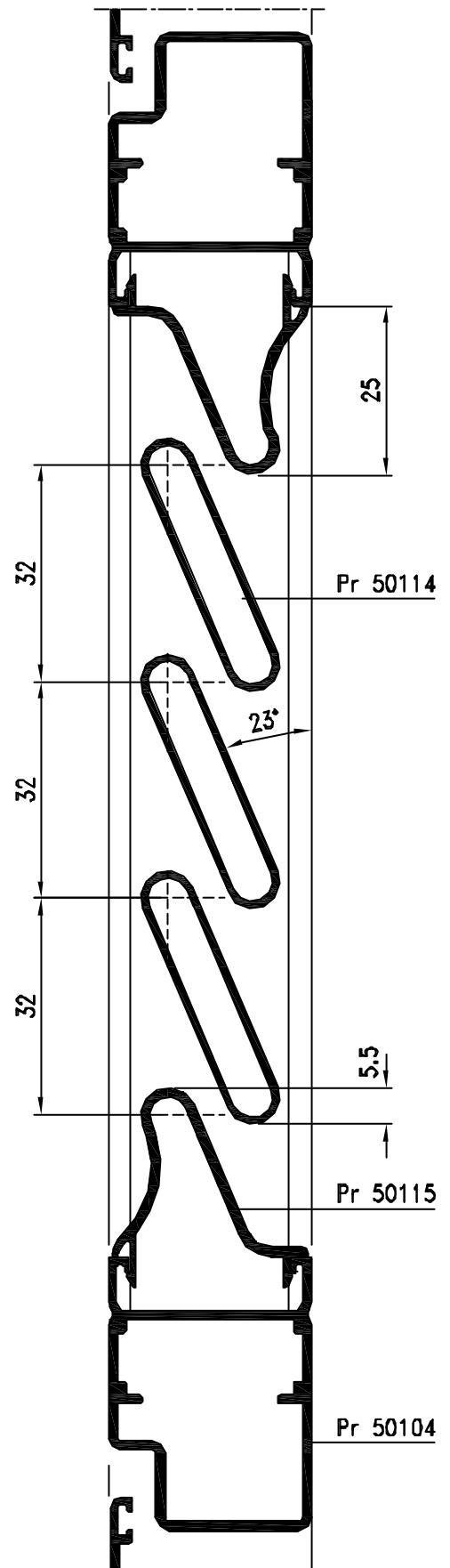

LAVORAZIONE CREMONESE Cod. 71C73

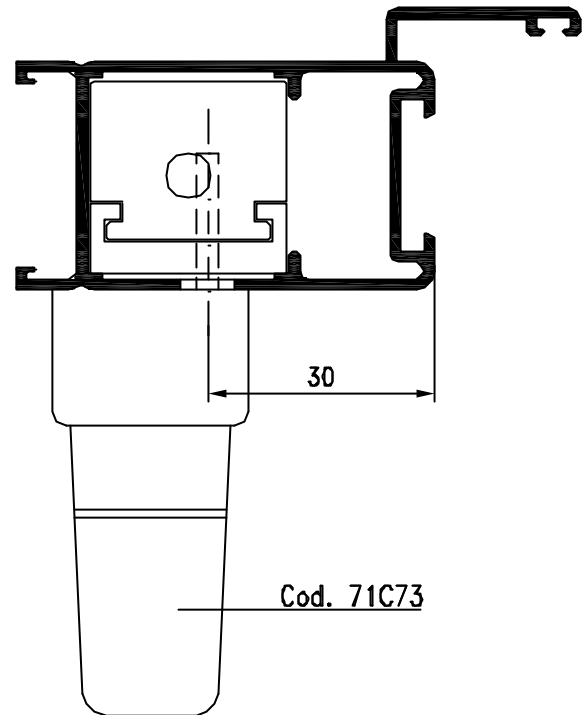
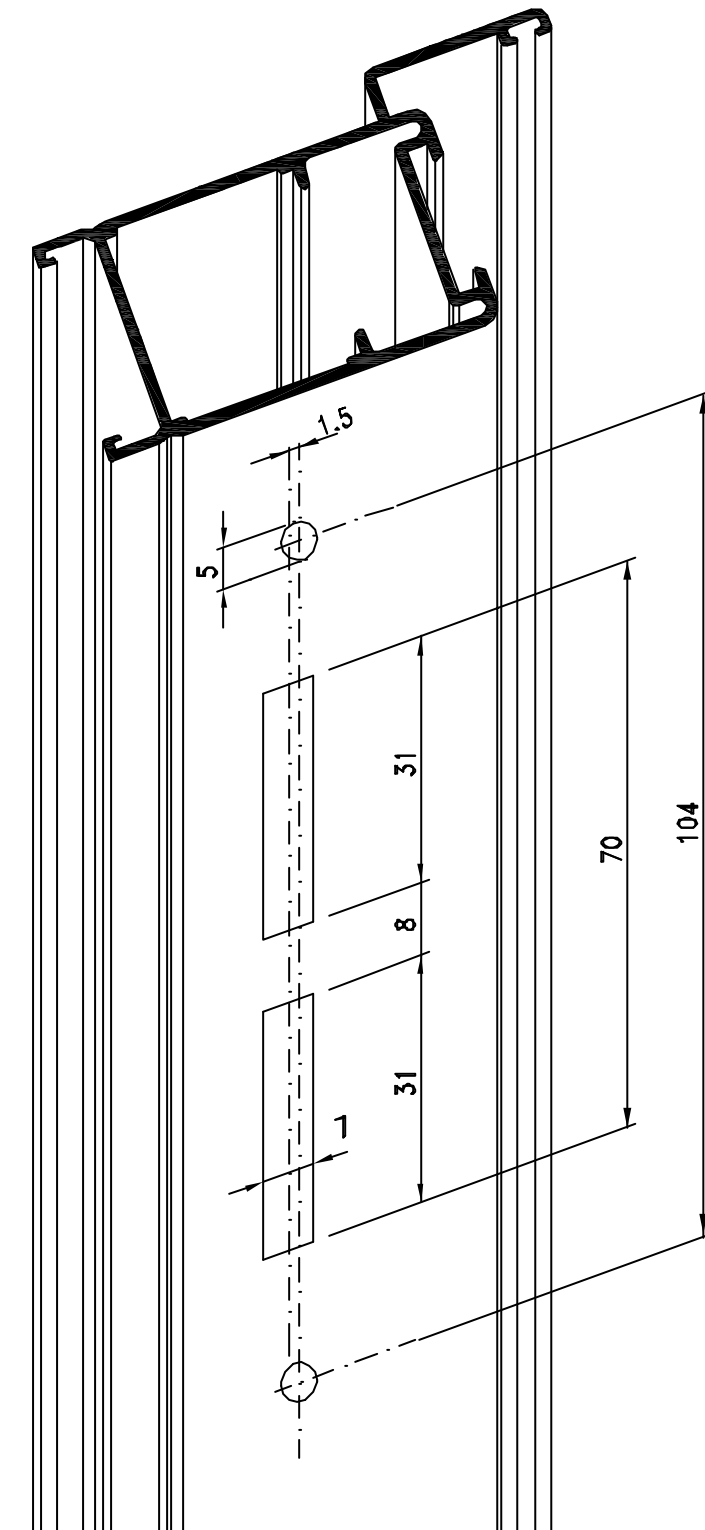

LAVORAZIONE SQUADRETTE

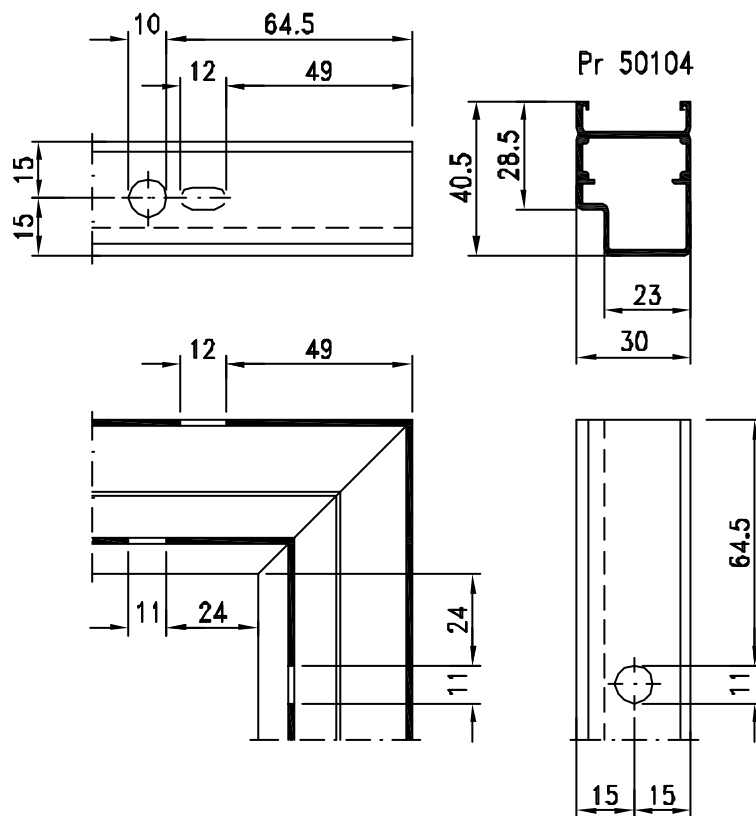
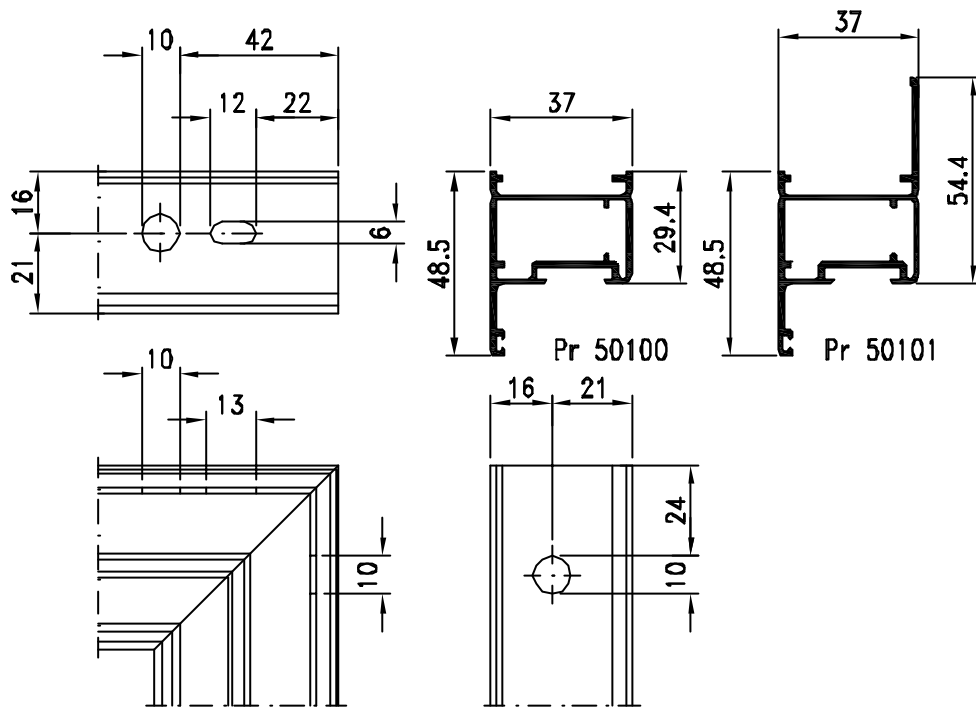

LAVORAZIONE SQUADRETTE

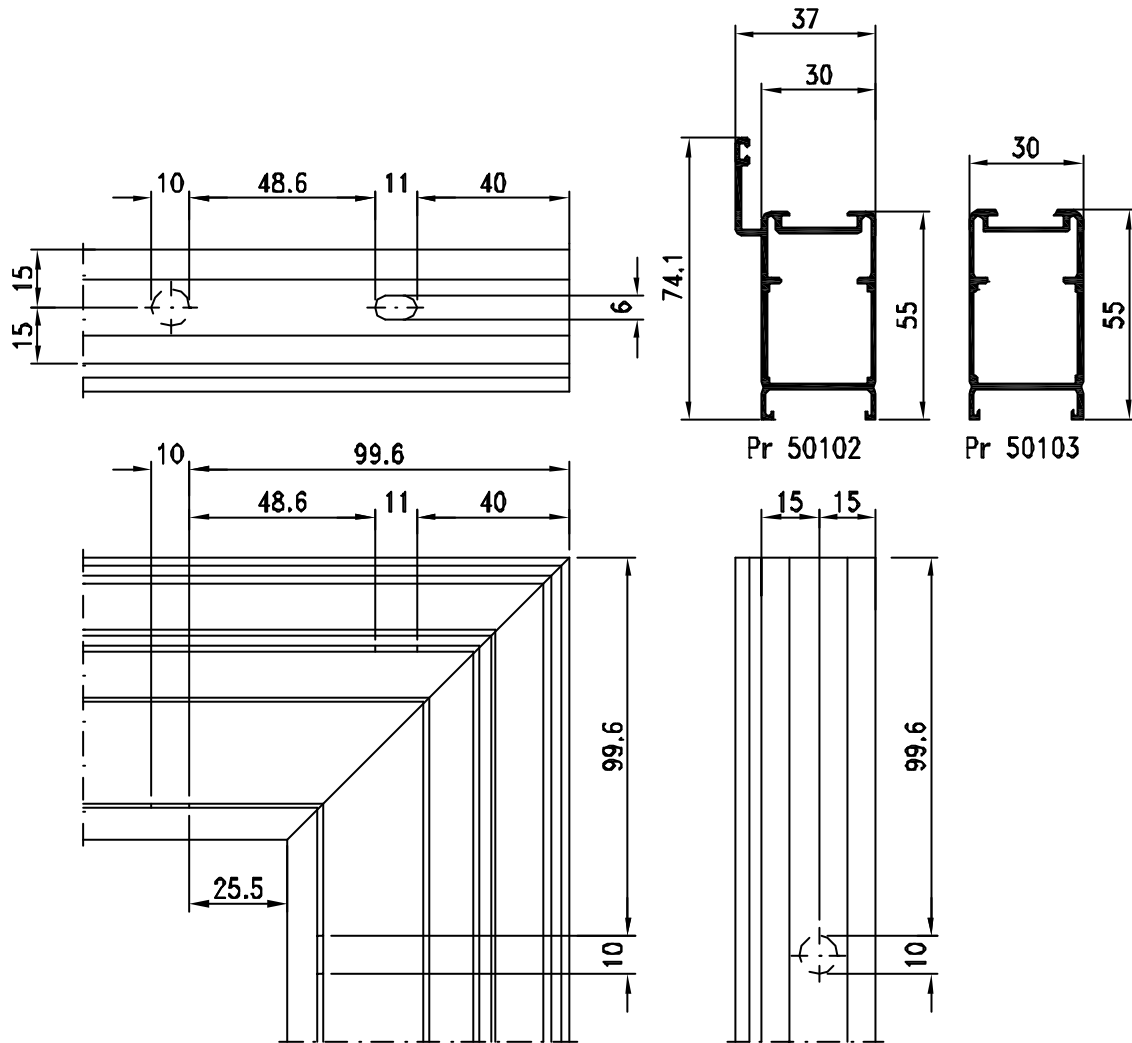







IDEALGELOSIA







INDICE IDEALGELOSIA

DESCRIZIONE	da pag.	a pag.
INDICE		299
ACCESSORI	301	307
SAGOMARIO PROFILATI	309	312
PROFILATI 1:1	313	317
SCHEMI E DISTINTE	319	322

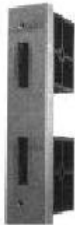

ACCESSORI	CODICE	COLORE	DESCRIZIONE	MATER.	CONFEZ.
	AW 042	NERO	TAPPO TERMINALE PER Pr 50003-50004	NYLON	PEZZI 200
	AW 043	NERO	TAPPO TERMINALE PER Pr 50008-50009	NYLON	PEZZI 200
	AW 050	GREZZO RAL1004K RAL7001K RAL9005 RAL6005K RAL8014 RAL9010	BRACCETTO PER SPORTELLO ALLA GENOVESE	ALLUMINIO	PEZZI 200
	AW 070	GREZZO RAL1004K RAL7001K RAL9005 RAL6005K RAL8014 RAL9010	CARDINE A MURARE	ACCIAIO	PEZZI 50
	AW 100	GREZZO RAL1004K RAL7001K RAL9005 RAL6005K RAL8014 RAL9010	CANTONALE CON OCCHIELLO PIANO	ALLUMINIO	PEZZI 50
	AW 101	RAL1004K RAL7001K RAL9005 RAL6005K RAL8014 RAL9010	SELLA REVERSIBILE PER OVALINA DA 50mm, Pr 50013	NYLON	PEZZI 750

ACCESSORI	CODICE	COLORE	DESCRIZIONE	MATER.	CONFEZ.
	AW 102	RAL1004K RAL7001K RAL9005 RAL6005K RAL8014 RAL9010	SELLA (DX. SX.) PER OVALINA DA 65mm, Pr 50012	NYLON	COPPIE 250
	AW 106	RAL9005 RAL6005K	SELLA REVERSIBILE PER OVALINA DA 80mm. Pr 50016	NYLON	PEZZI 300
	AW 112	GREZZO RAL1004K RAL7001K RAL9005 RAL6005K RAL8014 RAL9010	CERNIERA REVERSIBILE	ALLUMINIO	PEZZI 50
	AW 160	GREZZO RAL1004K RAL7001K RAL9005 RAL6005K RAL8014 RAL9010	CERNIERA IN LAMIERA PER SPORTELLO ALLA GENOVESE	ALLUMINIO	PEZZI 100
	AW 190	GREZZO RAL1004K RAL7001K RAL9005 RAL6005K RAL8014 RAL9010	BATTENTE A "Z"	NYLON	PEZZI 100
	AW 203	GREZZO	SQUADRETTA PER TUBOLARE 45x20mm	ALLUMINIO	PEZZI 200





ACCESSORI	CODICE	COLORE	DESCRIZIONE	MATER.	CONFEZ.
	AW 204	GREZZO	SQUADRETTA PER TUBOLARE 45x30mm	ALLUMINIO	PEZZI 150
	AW 301	RAL 6005K RAL 9005 RAL 9010	SELLA REVERSIBILE CON SPESSORE PER OVALINA DA 50 mm. Pr 50013	NYLON	PEZZI 1000
	AW 379	GREZZO	KIT DI COLLEGAMENTO E FISSAGGIO GUIDATO PER TUBOLARITA' DA 27mm	ALLUMINIO	PEZZI 30
	AW 400	NERO	ESPANSORE PER PERSIANA "OK RED" ALLA GENOVESE	NYLON	PEZZI 200
	AW 404	RAL 6005K RAL 9005	SELLA DOPPIA PER FRANCESINA Pr 50038 USARE CON OVALINA Pr 50013	NYLON	PEZZI 1000





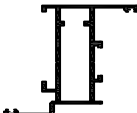
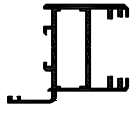
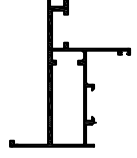
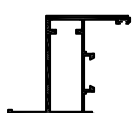
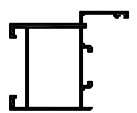

ACCESSORI	CODICE	COLORE	DESCRIZIONE	MATER.	CONFEZ.
	AW 410	NERO	BATTUTA A CILINDRO	NYLON	PEZZI 100
	AW 518	NERO	CHIOCCIOLA PER SPORTELLO ALLA GENOVESE	NYLON	PEZZI 2
	30 D 44	NERO	FERMO IMPOSTA AUTOMATICO GRILLO	NYLON	PEZZI 10
	30 D 48	NERO	FERMO IMPOSTA CON AMORTIZZATORE GRILLO TOP	NYLON	PEZZI 10
	40 C 03	GREZZO	PERNO DI COLLEGAMENTO ASTA PER Cod. 45 C A6 - AW 379	ACCIAIO	PEZZI 200
	45 C A6	GREZZO	KIT DI COLLEGAMENTO CREMONESE	ALLUMINIO	PEZZI 20



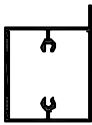
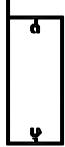
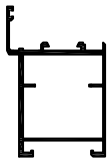
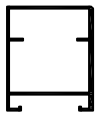



ACCESSORI	CODICE	COLORE	DESCRIZIONE	MATER.	CONFEZ.
	71 C 73	GREZZO RAL1013 RAL6005 RAL8014 RAL9005 RAL9010	CREMONESE MAXIMA PER APERTURE INTERNE/ESTERNE (DX)	ZAMA	PEZZI 10
	71 D 20	NERO	INCONTRO ASTA ESTERNA CON PUNTALE IN ACCIAIO	NYLON	PEZZI 250
	71 D 21	NERO	TERMINALE ASTA CON PUNTALE IN ACCIAIO	NYLON ACCIAIO	PEZZI 50
	80 D 35	NERO	TAPPO CHIUDIFORO DIAMETRO 11.5mm	PVC	PEZZI 1000
	96 V 88	NERO	BLOCCO INTESTATURA FOX 1		PEZZI 200
	96 V 89	NERO	BLOCCO INTESTATURA FOX 2		PEZZI 200

SEZIONE	CODICE	DESCRIZIONE	BOBINE m	SCATOLA m
	90 G 26	GUARNIZIONE PER BATTUTA MATERIALE: ELAPRENE COLORE: NERO	400	800
	90 G 69	GUARNIZIONE COPRIFILO A MURO PER Pr 50001 MATERIALE: EPDM COLORE: NERO	100	400
	90 G 82	GUARNIZIONE COPRIVITE DI FISSAGGIO Pr 50001 MATERIALE: EPDM COLORE: NERO	50	50

ATTREZZATURE	CODICE	DESCRIZIONE	CONFEZ.
	30 W 85	PUNZONATRICE PER SQUADRETTA AW 203 - AW 204	PEZZI 1

SEZIONE	CODICE	PESO Kg/m.	SUP. IN VISTA mm.	PAGINA	DESCRIZIONE
	Pr 11048	0,144	14	B02	PROFILATO ASTA DI CHIUSURA
	Pr 10763	0,347	111	B04	PROFILATO OVALINA mm. 50
	Pr 13199	0,448	141	B04	PROFILATO OVALINA mm. 65
	Pr 26214	0,923	112	B01	PROFILATO TELAIO
	Pr 26215	0,975	126	B02	PROFILATO ANTA PER MECCANISMO OEIENTABILE
	Pr 50001	1,026	100	B01	PROFILATO TELAIO CON FISSAGGIO A MURO
	Pr 50002	0,845	95	B01	PROFILATO TELAIO
	Pr 50003	0,867	128	B02	PROFILATO ANTA
	Pr 50004	0,653	135	B03	PROFILATO ANTA/SPORTELLO
	Pr 50005	0,653	98	B03	PROFILATO FRANCESINA H 30 mm.

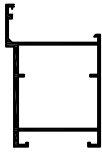
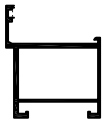
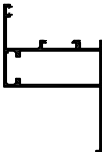
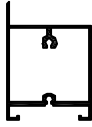
SEZIONE	CODICE	PESO Kg/m.	SUP. IN VISTA mm.	PAGINA	DESCRIZIONE
	Pr 50006	0,918	212	B03	PROFILATO ZOCCOLO H 62 mm.
	Pr 50007	1,550	318	B05	PROFILATO ZOCCOLO H 114 mm.
	Pr 50008	1,048	162	B02	PROFILATO ANTA MAGGIORATA
	Pr 50009	0,832	169	B03	PROFILATO ANTA ABBINAMENTO 50008
	Pr 50010	0,267	70	B05	PROFILATO BATTUTA RIPORTATA PER SPORTELLO
	Pr 50011	0,132	41	B03	PROFILATO FRANCESINA A SCATTO
	Pr 50012	0,435	138	B04	PROFILATO OVALINA SAGOMATA mm. 65
	Pr 50013	0,240	111	B04	PROFILATO OVALINA mm. 50 (ALLEGGERITA)
	Pr 50014	0,545	60	B04	PROFILATO CORNICE CENTRO STORICO
	Pr 50015	0,675	132	B03	PROFILATO SPORTELLO

SEZIONE	CODICE	PESO Kg/m.	SUP. IN VISTA mm.	PAGINA	DESCRIZIONE
	Pr 50016	0,554	168	B04	PROFILATO OVALINA mm. 80
	Pr 50017	0,432	49	B04	PROFILATO CORNICE CENTRO STORICO PER Pr 50016
	Pr 50018	1,126	186	B05	PROFILATO DOGA PER SCURI
	Pr 50019	0,505	54	B04	PROFILATO PER MECCANISMI ORIENTABILI
	Pr 50020	0,969	158	B02	PROFILATO ANTA MAGGIORATA FB12
	Pr 50021	0,813	124	B02	PROFILATO ANTA FB 12
	Pr 50023	0,907	110	B01	PROFILATO TELAIO
	Pr 50024	0,918	187	B03	PROFILATO ZOCCOLO H 62 mm.
	Pr 50034	0,497	94	B04	PROFILATO DI CHIUSURA Pr 50017
	Pr 50039	1,431	216	B05	PROFILATO FASCIA H 95 mm.

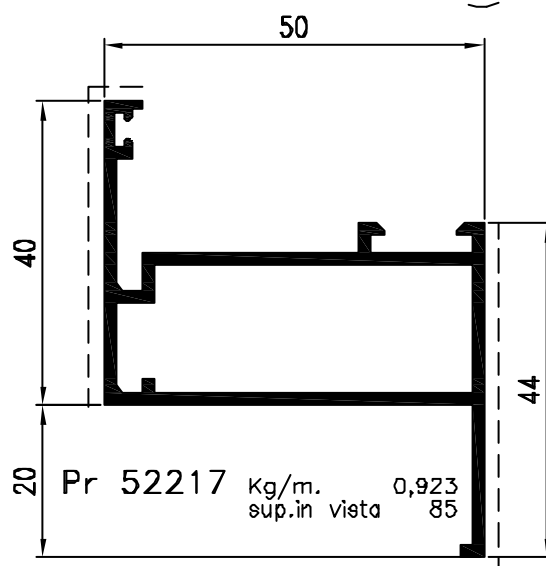
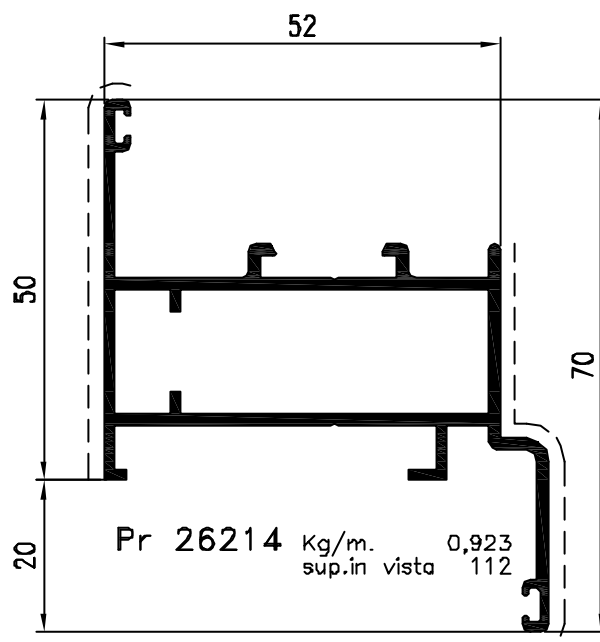
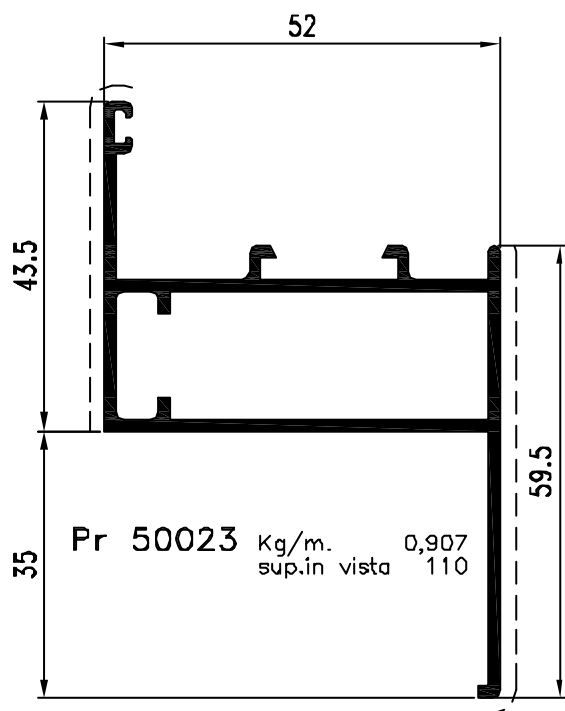
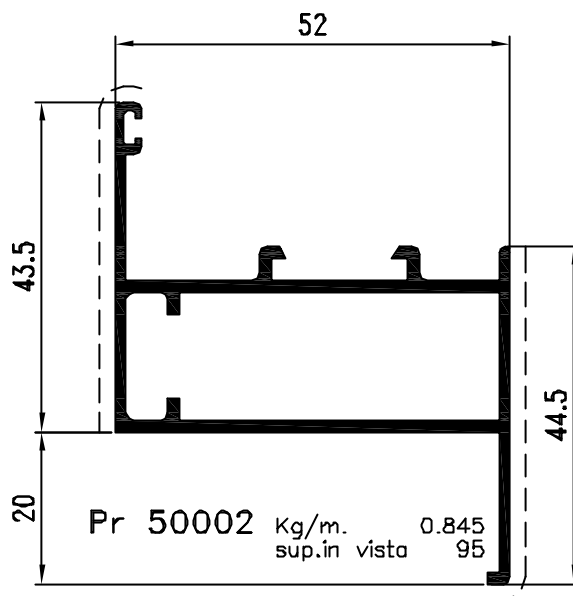
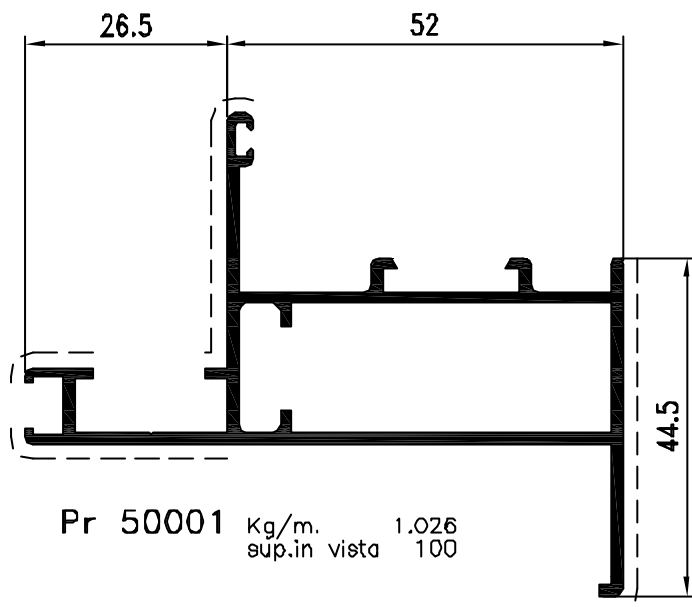

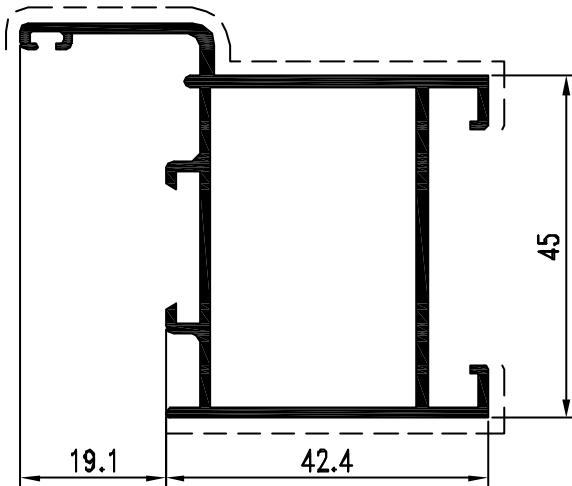

Pr. 50003 kg/m. 0.867
sup. in vista mm. 128

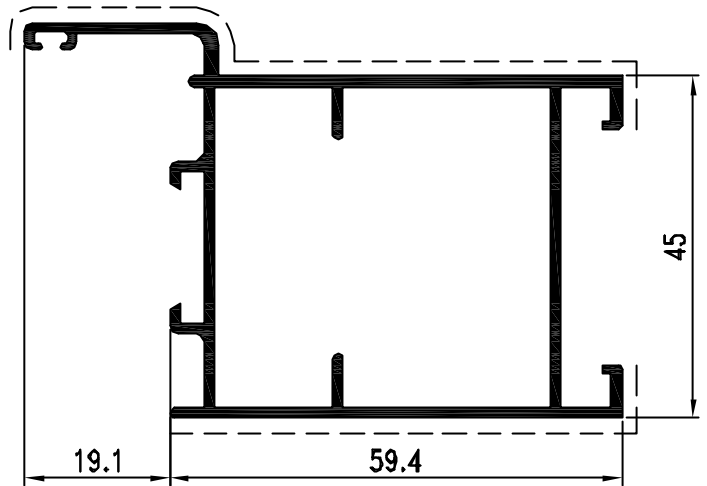

Pr. 50008 kg/m. 1.048
sup. in vista mm. 162

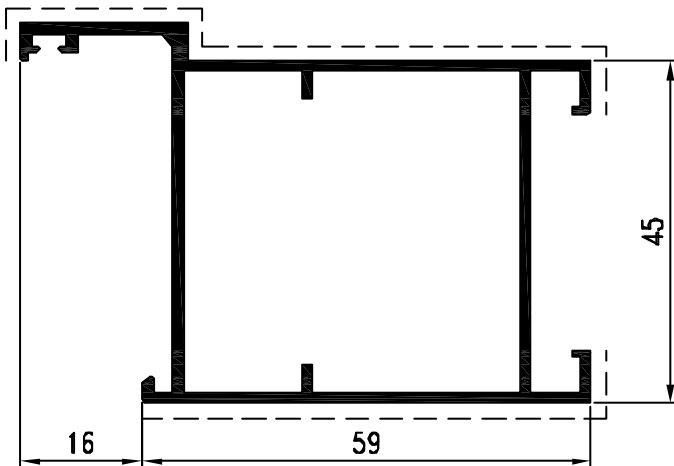

Pr. 50020 kg/m. 0.969
sup. in vista mm. 158

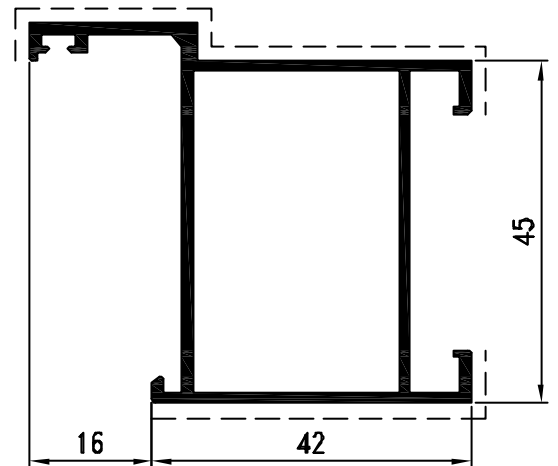

Pr. 50021 kg/m. 0.813
sup. in vista mm. 124

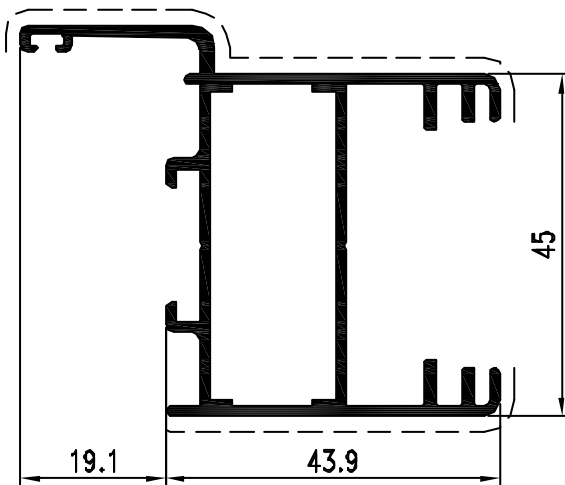

Pr. 26215 kg/m. 0.975
sup. in vista mm. 126

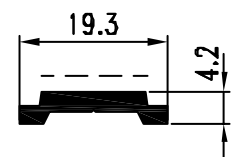

Pr. 11048 kg/m. 0.144
sup. in vista mm. 14

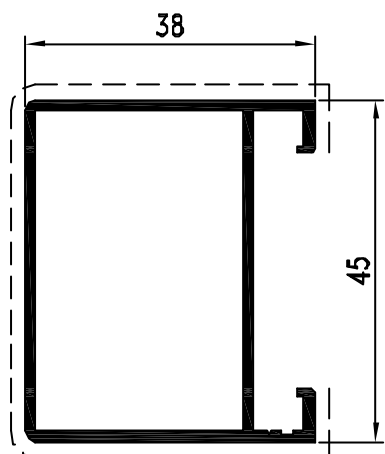

Pr. 50004 kg/m. 0.653
sup. in vista mm. 135

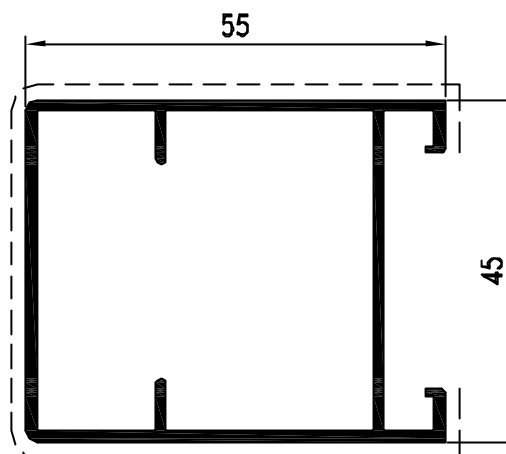

Pr. 50009 kg/m. 0.832
sup. in vista mm. 169

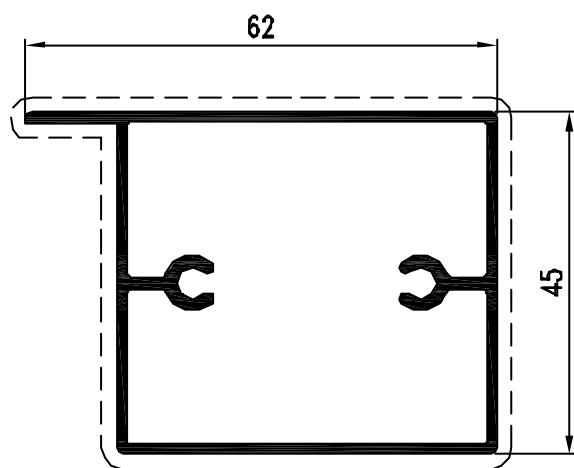

Pr. 50006 kg/m. 0.918
sup. in vista mm. 212

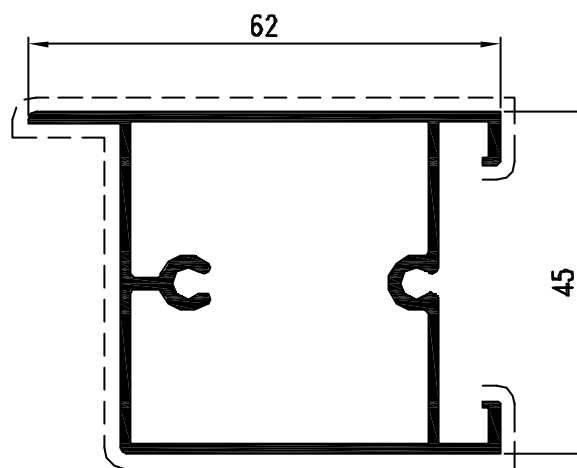

Pr. 50024 kg/m. 0.918
sup. in vista mm. 187

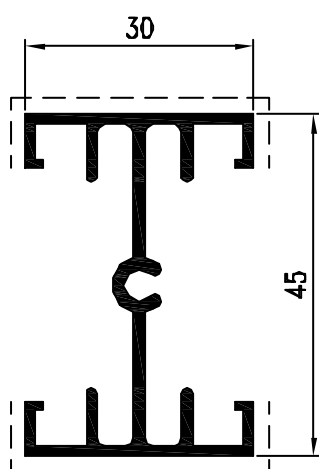

Pr. 50005 kg/m. 0.653
sup. in vista mm. 98

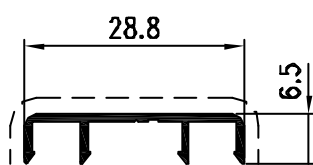

Pr. 50011 kg/m. 0.132
sup. in vista mm. 41

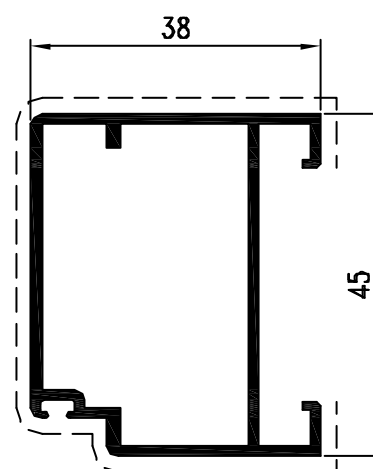

Pr. 50015 kg/m. 0.675
sup. in vista mm. 132

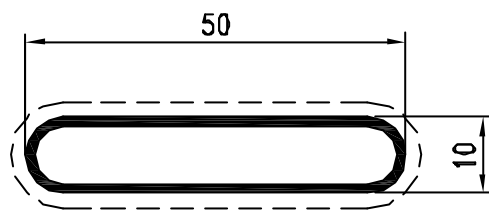

Pr. 10763 kg/m. 0.347
sup. in vista mm. 111

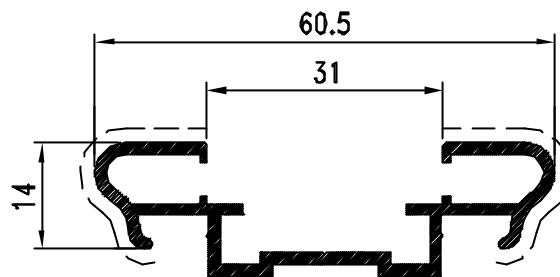

Pr. 50014 kg/m. 0.545
sup. in vista mm. 60

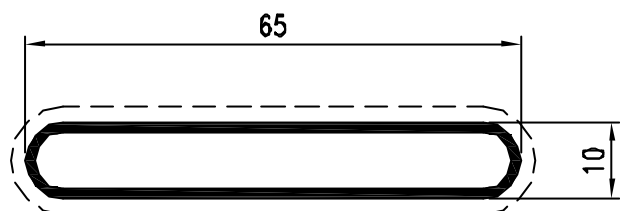

Pr. 13199 kg/m. 0.448
sup. in vista mm. 141

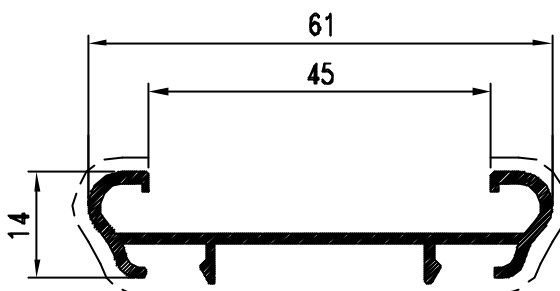

Pr. 50017 kg/m. 0.432
sup. in vista mm. 49

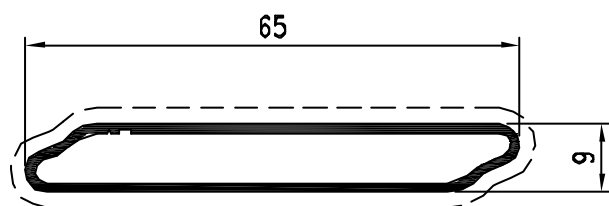

Pr. 50012 kg/m. 0.435
sup. in vista mm. 138

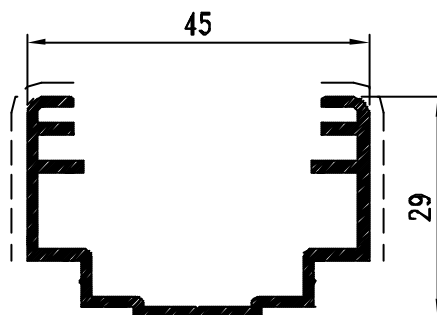

Pr. 50019 kg/m. 0.505
sup. in vista mm. 54

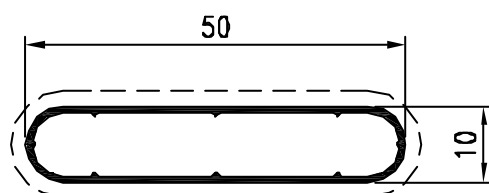

Pr. 50013 kg/m. 0.240
sup. in vista mm. 111

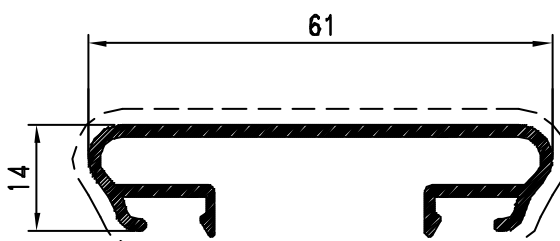

Pr. 50034 kg/m. 0.497
sup. in vista mm. 94

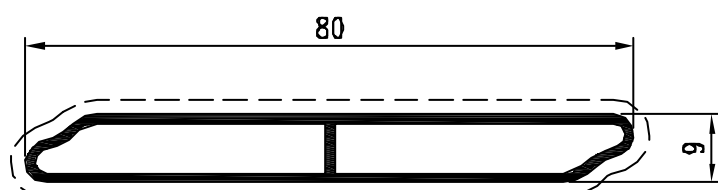

Pr. 50016 kg/m. 0.554
sup. in vista mm. 168

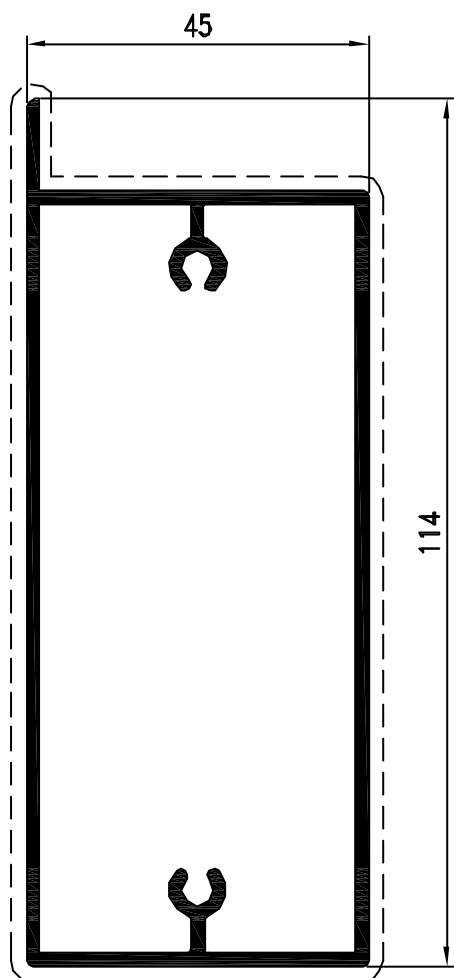

Pr. 50007 kg/m. 1.550
sup. in vista mm. 318

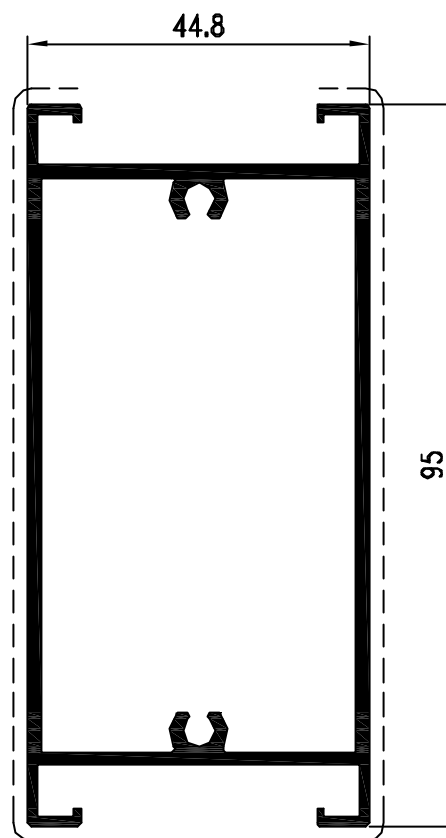

Pr. 50039 kg/m. 1.431
sup. in vista mm. 216

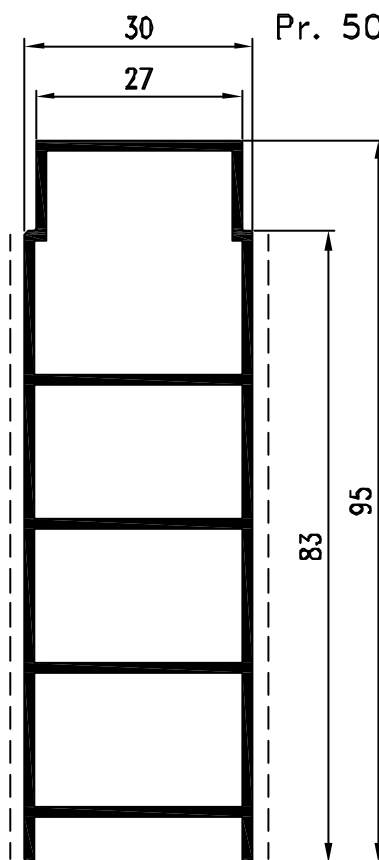

Pr. 50018 kg/m. 1.126
sup. in vista mm. 186

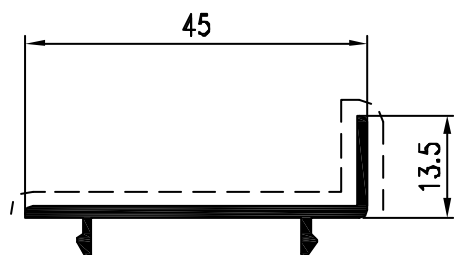

Pr. 50010 kg/m. 0.267
sup. in vista mm. 70

PROSPETTO ESTERNO

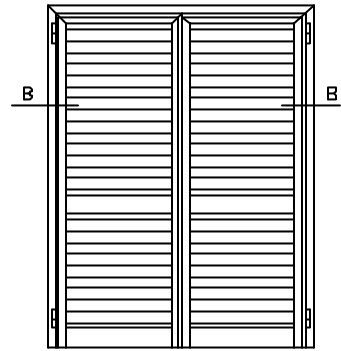

PROFILI

N° Pezzi	Pr	Descrizione	Taglio
2	50001	Montante telaio	H+20
1	50001	Traversa superiore telaio	L+40
4	50003	Mantante anta	H-28
2	50003	Traversa superiore	L:2-5
4	50006	Traversa inf. anta e traverso cent.	L:2-113
$\frac{H-185}{36.5} \times 2$	50013	Ovalina da 50mm.	L:2-113

LA SEZIONE VERTICALE E' A PAGINA C 02

Sez. B-B

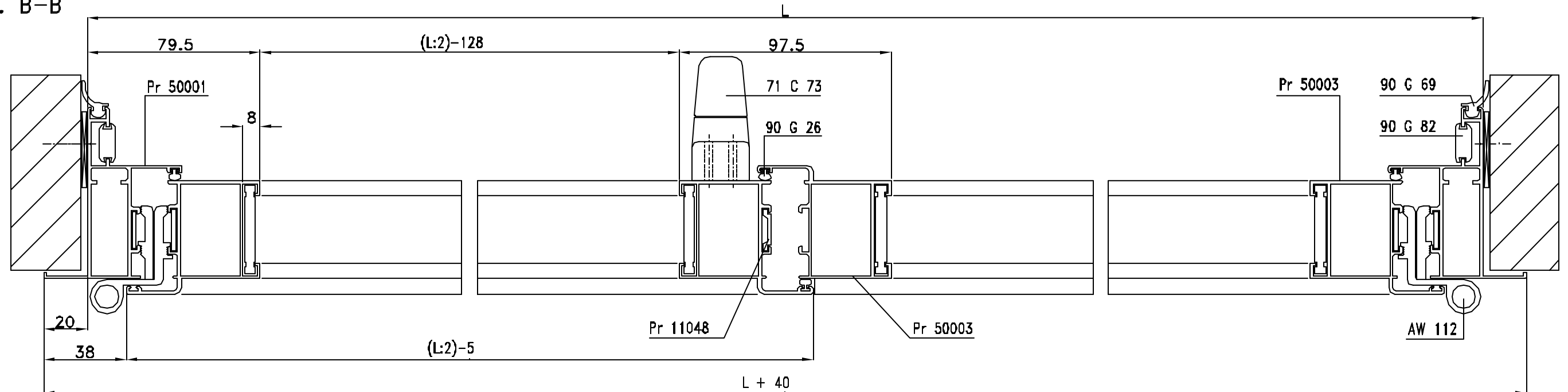

PROSPETTO ESTERNO

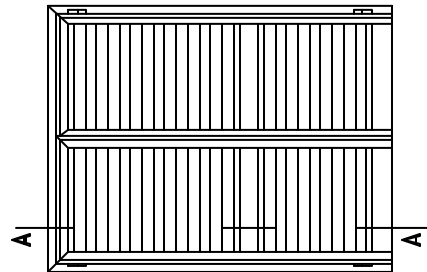

Sez. A-A

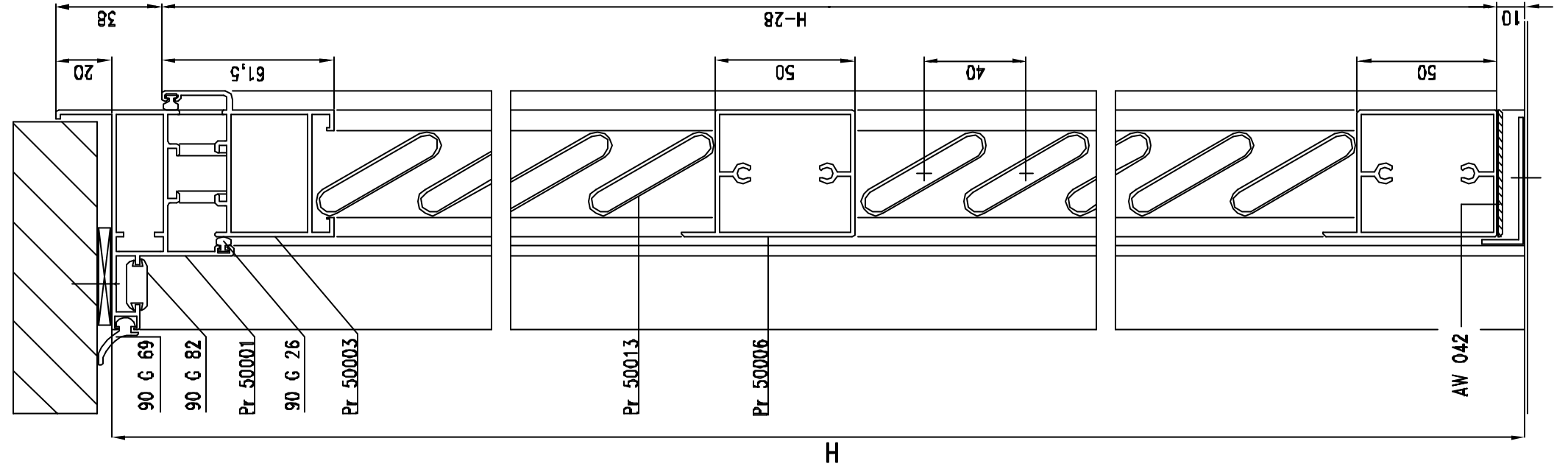

LA SEZIONE ORIZZONTALE E' A PAGINA C 01

PROSPETTO ESTERNO

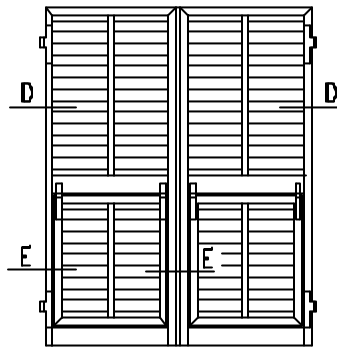

PROFILI

N° Pezzi	Pr	Descrizione	Taglio
2	50004	Mantante laterale anta	H-15
2	50003	Mantante centrale anta	H+13.5
2	50004	Traversa superiore anta	L:2-13
4	50006	Traversa inf. anta e traverso cent.	L:2-72
2	50005	Mantante sportello francesina	H1+15
2	50005	Mantante francesina(parte sup. fissa)	H-230.5-H1
4	50004	Mantante sportello	H1+77.5
4	50004	Traversa sportello	L:2-103
4	50010	Mantante riporto per sportello	H1+5
2	50010	Traversa riporto per sportello	L:2-77
H-230 36.5 x 2	50013	Ovalina da 50mm.(parte sup. fissa)	L:4-43
	50013	Ovalina da 50mm.(sportello)	L:4-89

LA SEZIONE VERTICALE E' A PAGINA C 04

Sez. D-D

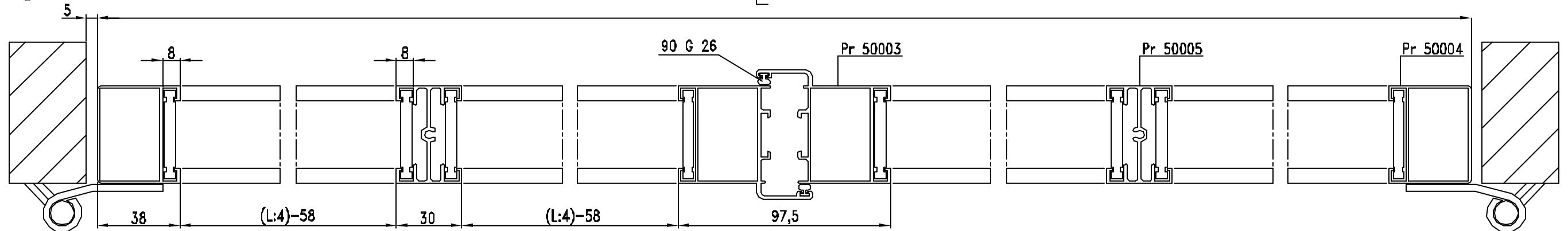

Sez. E-E

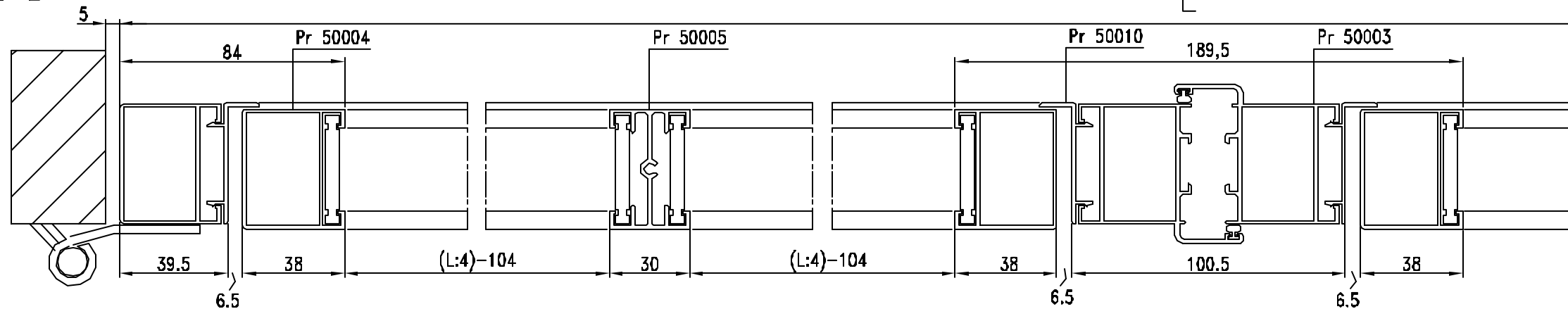

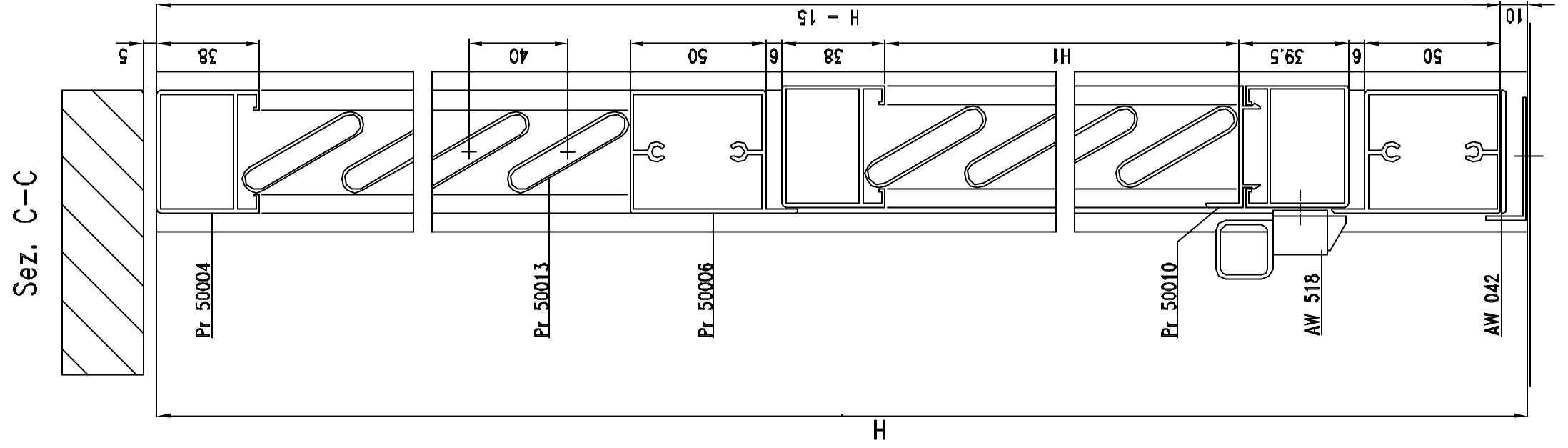

LA SEZIONE ORIZZONTALE E' A PAGINA C 03

PROSPETTO ESTERNO

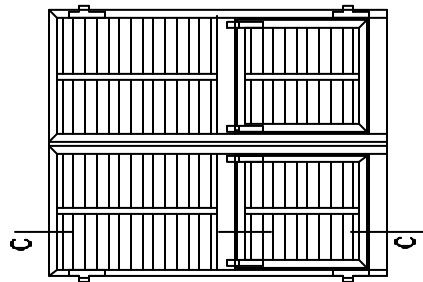

DOMAL SUDNY PIACENTINA









Hydro
Building
Systems

INDICE SUNNY PIACENTINA

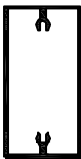
DESCRIZIONE	da pag.	a pag.
INDICE		325
ACCESSORI	327	328
SAGOMARIO PROFILATI		329
PROFILATI 1:1	331	332
SCHEMI E DISTINTE	333	334
SEZIONI 1:1		335

ACCESSORI	CODICE	COLORE	DESCRIZIONE	MATER.	CONFEZ.
	04 A 21	GREZZO	SQUADRETTA PRESSOFUSA A SCATTO PER Pr 24451 - Pr24455 D. 40 E PIACENTINA	ALLUMINIO	PEZZI 250
	30B110D 30B110S	GREZZO RAL9005 RAL8017 RAL6005	CARDINE PER ANTA STORICA FISSAGGIO INTERNO	ALLUMINIO	PEZZI 20Dx PEZZI 20Sx
	30B111D 30B111S	GREZZO RAL9005 RAL8017 RAL6005	CARDINE PER ANTA STORICA FISSAGGIO INTERNO CON PERNO REGOLABILE	ALLUMINIO	PEZZI 20Dx PEZZI 20Sx
	30B114	GREZZO	KIT FISSAGGIO CARDINI	ALLUMINIO	KIT 20
	30B116	GREZZO	TAPPO DI SICUREZZA PER Cod. 30 B 110 Cod. 30 B 111 - 30 B 112 - 30 B 115	OTTONE- ACC.INOX	PEZZI 20
	30B120D 30B120S	GREZZO RAL9005 RAL8017 RAL6005	CARDINI DX-SX PER TERZA ANTA STORICA FISSAGGIO ESTERNO	ALLUMINIO	PEZZI 20Dx PEZZI 20Sx
	30B121	GREZZO RAL9005 RAL8017 RAL6005	CARDINI DX-SX A SQUADRO PER ANTA STORICA FISSAGGIO ESTERNO CON PERNO REGOLABILE	ALLUMINIO	COPPIE 10
	30 D 25	NERO	TAPPO DX E SX PER Pr 10763 GELOSIA A LAMELLE FISSE A 30°	NYLON	COPPIE 100

ACCESSORI	CODICE	COLORE	DESCRIZIONE	MATER.	CONFEZ.
	30 D 26	NERO	TAPPO DX E SX PER Pr 13199 GELOSIA A LAMELLE FISSE A 30°	NYLON	COPPIE 100
	30 D 84	NERO	TAPPI PER OVALINA Pr 10763 FISSA CHIUSA	NYLON	COPPIE 200
	30 D 90	NERO	COPPIA TAPPI per Pr 26225	NYLON	PEZZI 100
	30 D 150	RAL 9005	TAPPO CHIUDI TUBOLARITA' per Pr 31926	NYLON	COPPIE 100
<div style="border: 1px solid black; border-radius: 15px; padding: 5px; display: inline-block;"> PER GLI ACCESSORI "AGB" FARE RIFERIMENTO ALLA SUNNY P60 STORICA </div>					

SEZIONE	CODICE	PESO Kg/m.	SUP. IN VISTA mm.	PAGINA	DESCRIZIONE
	Pr 03361	1,277	240	B01	PROFILATO FASCIA/ZOCCOLO mm. 80
	Pr 10763	0,347	111	B02	PROFILATO OVALINA mm. 50
	Pr 13199	0,448	141	B02	PROFILATO OVALINA mm. 65
	Pr 26225	0,526	99	B01	PROFILATO DI RIPORTO CENTRALE (STULP)
	Pr 31926	1,007	183	B01	PROFILATO ANTA
	Pr 31927	2,168	400	B01	PROFILATO ZOCCOLO mm. 160
	Pr 50013	0,240	111	B02	PROFILATO OVALINA mm. 50 (ALLEGGERITA)

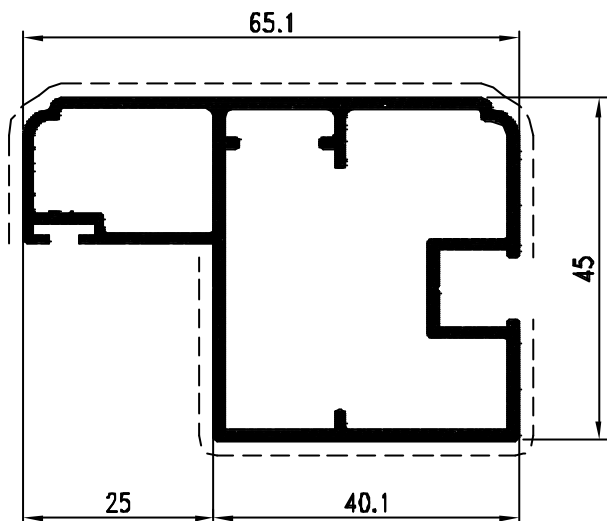

Pr. 31926 kg/m. 1.007
sup. in vista mm. 183

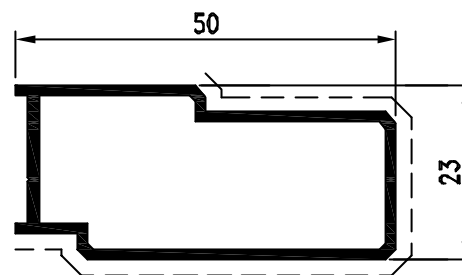

Pr. 26225 kg/m. 0.526
sup. in vista mm. 99

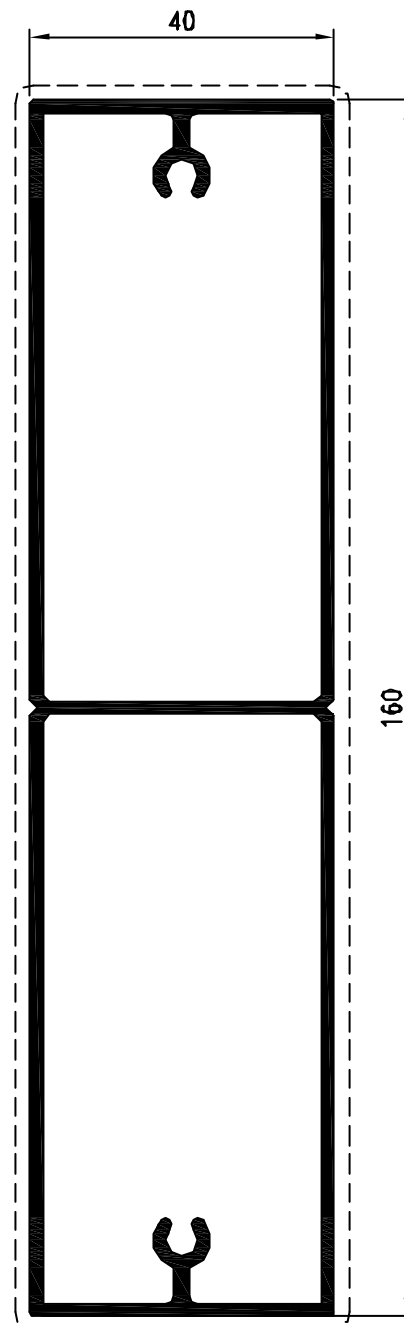

Pr. 31927 kg/m. 2.168
sup. in vista mm. 400

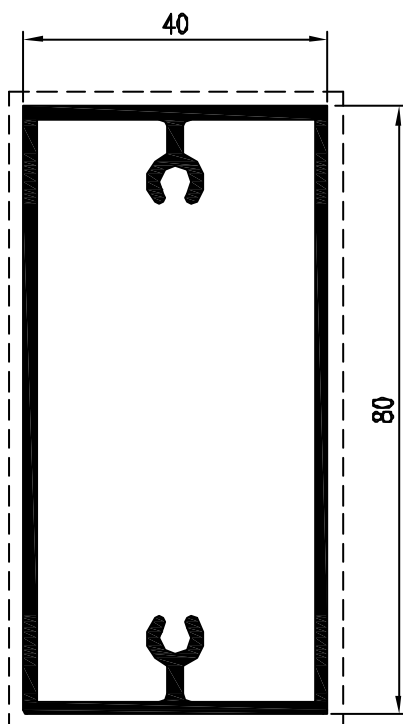

Pr. 03361 kg/m. 1.277
sup. in vista mm. 240

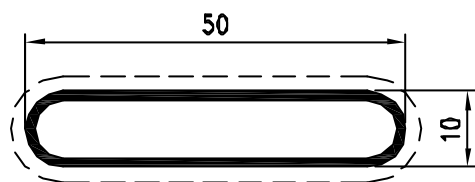

Pr. 10763 kg/m. 0.347
sup. in vista mm. 111

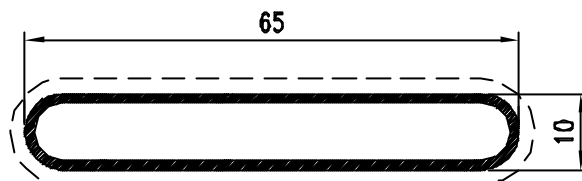

Pr. 13199 kg/m. 0.448
sup. in vista mm. 141

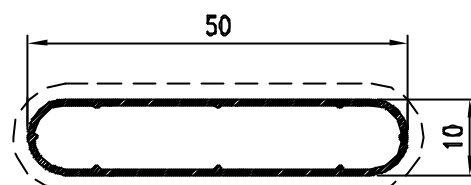

Pr. 50013 kg/m. 0.240
sup. in vista mm. 111

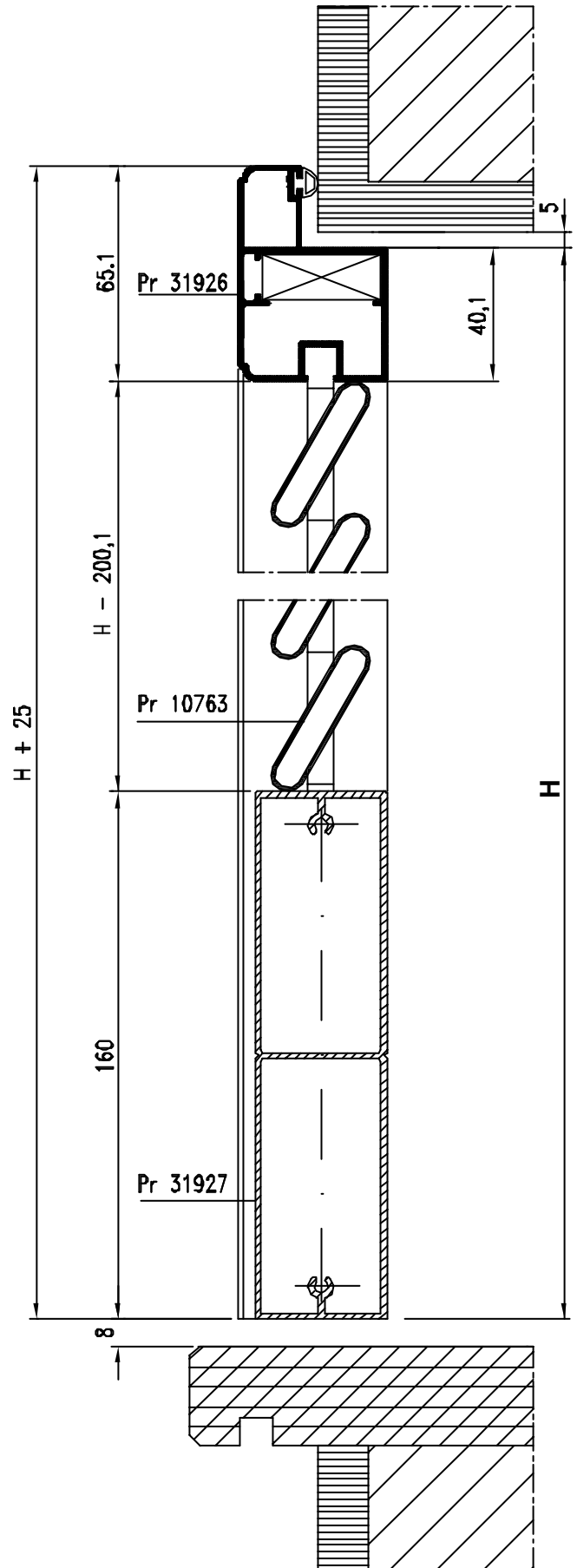
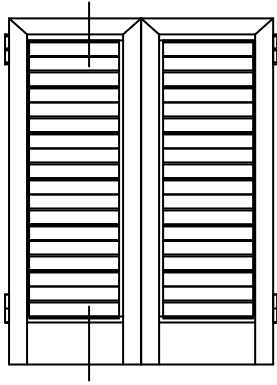

SEZIONI ORIZZONTALI

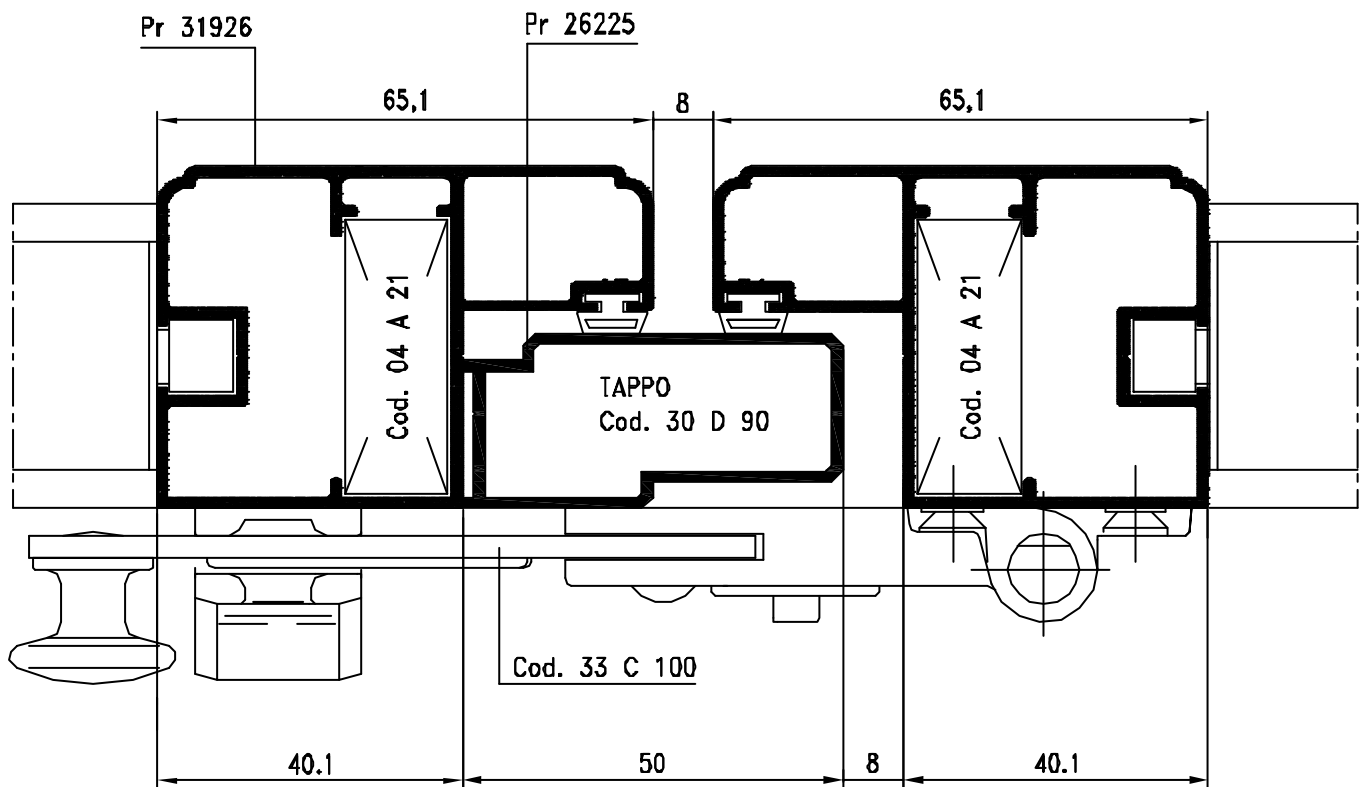
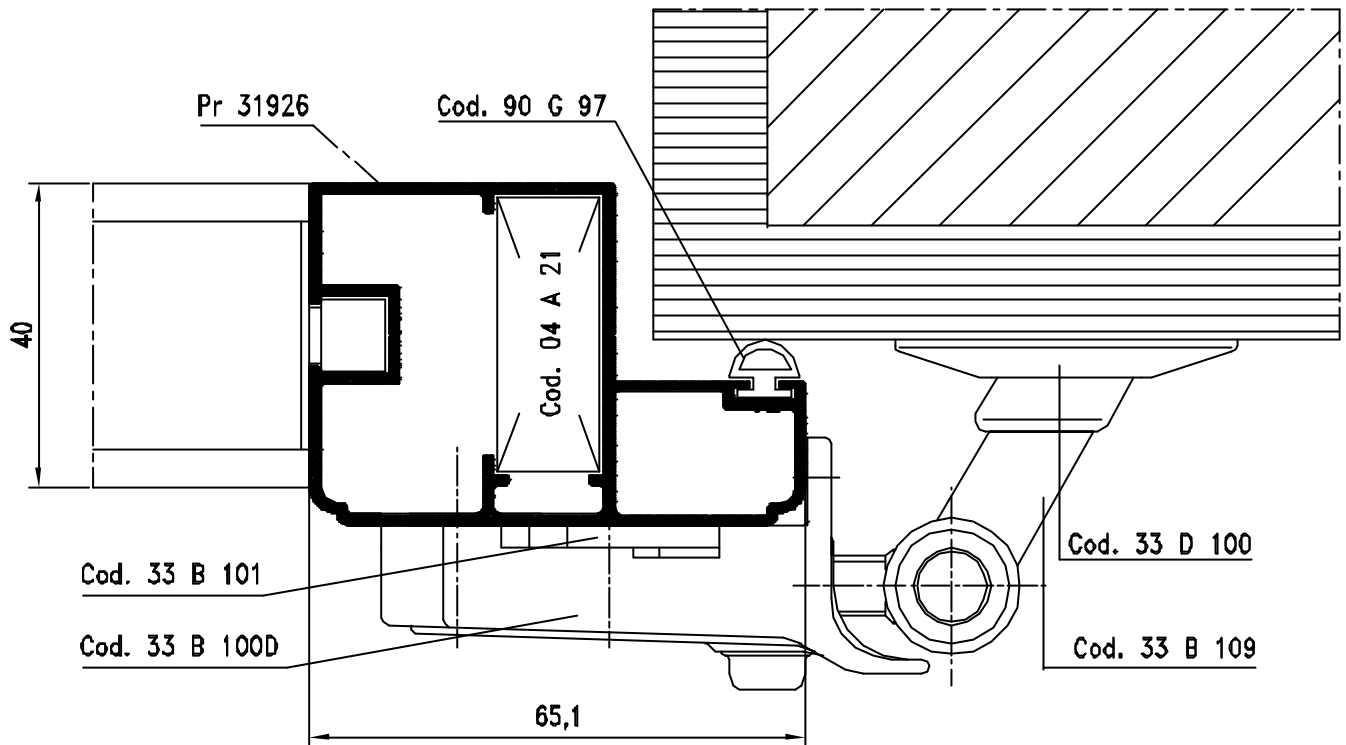



L'ALLUMINIO È DI CASA.

Hydro Building Systems S.p.A

20060 ORNAGO (MI)-Via Meucci, 5
Tel. 039 60281 (10 linee)-Telefax 039 6028222