

**Domal Slide C160 MT**  
**Scorrevoli**







## CONSIGLI PRATICI PER:

- LAVORAZIONE
- PROTEZIONE
- PULIZIA
- MANUTENZIONE

## DELL' ALLUMINIO VERNICIATO ED OSSIDATO

1. **IMBALLAGGIO.** Impiegare la giusta protezione, evitando di esporre il profilo protetto direttamente ai raggi solari. In ogni caso il prodotto impiegato per eventuali reimpballi deve essere compatibile con la verniciatura o con l'ossidazione ed occorre seguire le istruzioni del fornitore.
2. **LAVORAZIONE.** Durante tutte le fasi di lavorazione manovrare i profilati con estrema delicatezza ed accertarsi che l'ambiente di lavoro sia pulito. Usare la massima cura nella movimentazione dei pezzi. Evitare il contatto con scorie o residui di limature delle lavorazioni precedenti.
3. **ATTREZZATURE.** Accertarsi che i macchinari e gli utensili siano sempre efficienti ed adatti al compito da svolgere, in particolare le lame e le troncatrici. Per il raffreddamento degli utensili evitare prodotti che possono intaccare la colorazione dei profilati e pregiudicarne la qualità.
4. **SIGILLATURA.** Sigillare accuratamente con prodotti idonei tutti i tagli e/o fori di lavorazione del serramento, bloccando ogni zona soggetta ad infiltrazione. Accertarsi sempre che ci sia un corretto drenaggio all'interno dello scatolato del serramento.
5. **ACCESSORI.** Utilizzare esclusivamente accessoristica di ottima qualità. La viteria deve sempre essere in materiale adatto e, possibilmente, isolato. Ricordare sempre che tutto ciò che non è alluminio, ma è in contatto con quest'ultimo, può creare problemi di corrosione. Evitare l'uso delle squadrette in ferro non opportunamente trattate.
6. **LUBRIFICANTI.** Eseguire con particolare attenzione ed appositi olii la lubrificazione dell'accessoristica.
7. **POSA IN OPERA.** La buona norma richiede sempre di installare per ultimo il serramento in alluminio, evitando in questo modo possibili inconvenienti dovuti al contatto con sostanze presenti in cantiere che possono danneggiare le superfici verniciate o anodizzate.
8. **MANUTENZIONE E PULIZIA.** Per mantenere il più possibile inalterate nel tempo le superfici anodizzate o verniciate, è necessario che le stesse vengano opportunamente pulite con prodotti appositi.

### In ogni caso si raccomanda vivamente di:

- Pulire le superfici quando non sono esposte a fonti di calore diretto, ad esempio i raggi solari.
- Usare per la pulizia una spugna o un panno bagnato con l'apposito detergente.
- Il detergente deve essere: neutro, non abrasivo, non a base di ammoniaca, non a base di cloro (ad esempio candeggina).
- Le parti meccaniche debbono essere: pulite ed oliate tramite spray al silicone oppure al teflon e controllate anche a livello di usura.

**La Sapa Building Systems S.P.A. fornisce prodotti con finiture garantite dai marchi QUALANOD e QUALICOAT**



## CONTENUTO

Prima pagina.....	0
Contenuto.....	1
Indice.....	5

### A INFORMAZIONI SISTEMA

2-binari.....	A.1.1
3-binari.....	A.2.1
Tagli 90°.....	A.3.1
1-binario.....	A.4.1
1-binario - Soglia ribassata.....	A.5.1
Opzioni termiche.....	A.6.1
Direttive generali.....	A.7.1
Risultati dei test.....	A.8.1

### B PROFILATI SISTEMA

Lista dei simboli.....	B.0.1
Lista profilati.....	B.1.1
Telaio.....	B.2.1
Anta.....	B.3.1
Rinforzo.....	B.4.1
Profilati cartelline.....	B.5.1
Profilati gocciolatoi.....	B.6.1
Profilati guida.....	B.7.1
Profilati complementari.....	B.8.1
Momento di inerzia.....	B.9.1

### C PROFILATI VARI

Finestre - Profilati di finitura.....	C.1.1
---------------------------------------	-------

### D VETRATURA

Tabella vetratura.....	D.1.1
Vetratura con RU0004.....	D.1.1
Vetratura con RU0002.....	D.1.2
Fermavetro.....	D.2.1
Accessori.....	D.2.2

### E ACCESSORI

Squadrette - Squadrette con spine coniche.....	E.1.1
Squadrette - Squadrette con eccentrico.....	E.1.2
Squadrette - Accessori per squadrette.....	E.2.1
Squadrette - Squadrette di allineamento.....	E.2.2
Guarnizioni - Finestre.....	E.3.1
Guarnizioni - Varie.....	E.3.3
Guarnizioni - Guarnizioni di sistema.....	E.3.4
Accessori - Finestre.....	E.4.1
Accessori - Varie.....	E.4.3
Accessori - Accessori di sistema.....	E.4.4
Viti.....	E.5.1

### F SELEZIONE FERRAMENTA

Panoramica.....	F.1.1
Alzante-scorrevole.....	F.1.2
Maniglie standard.....	F.1.2
Maniglie S-Line (Harmony).....	F.1.3
Hv = 1303 - 1903.....	F.1.4
Hv = 1904 - 2803.....	F.1.5
Hv = 2804 - 3403.....	F.1.6
Angolo galleggiante.....	F.1.7
Alzante-scorrevole - Schema 4 ante.....	F.1.8
Pezzi supplementari.....	F.1.8
Lista articoli ferramenta.....	F.2.1

### G ATTREZZATURE

Lavorazione - D5110000.....	G.1.1
Dime lavorazioni - Panoramica.....	G.2.1
Dime lavorazioni - TG4116.....	G.2.2

### H NODI

Nodi - Panoramica.....	H.0.1
Nodi.....	H.1.1
Alzante-scorrevole C9V001-C9K020 - Superiore destro.....	H.1.1
Alzante-scorrevole C9V001-C9K020 - Inferiore destro.....	H.1.1
Alzante-scorrevole C9V001-C9K020 - Sinistro.....	H.1.2
Alzante-scorrevole C9V001-C9K020 - Destro.....	H.1.3
Alzante-scorrevole C9V001-C9K020 - Centrale.....	H.1.4
Alzante-scorrevole C9V001-C9K120/C9K121 - Superiore destro.....	H.1.6
Alzante-scorrevole C9V001-C9K120/C9K121 - Inferiore destro.....	H.1.6
Alzante-scorrevole C9V001-C9K120/C9K121 - Sinistro.....	H.1.7
Alzante-scorrevole C9V001-C9K120/C9K121 - Destro.....	H.1.8
Alzante-scorrevole C9V001-C9K120/C9K121 - Inferiore destro.....	H.1.9
Alzante-scorrevole C9V001-C9K030 - Superiore destro.....	H.1.10
Alzante-scorrevole C9V001-C9K030 - Sinistro.....	H.1.11
Alzante-scorrevole C9V001-C9K030 - Destro.....	H.1.12
Alzante-scorrevole C9V001-C9K030 - Centrale.....	H.1.13
Alzante-scorrevole-anta fissa C9V001-C9K020 - Superiore sinistro.....	H.1.15
Alzante-scorrevole-anta fissa C9V001-C9K020 - Inferiore Superiore.....	H.1.15
Alzante-scorrevole-anta fissa C9V001-C9K020 - Superiore destro.....	H.1.16
Alzante-scorrevole-anta fissa C9V001-C9K020 - Inferiore destro.....	H.1.16
Alzante-scorrevole-anta fissa C9V001-C9K020 - Sinistro.....	H.1.17
Alzante-scorrevole-anta fissa C9V001-C9K020 - Destro.....	H.1.18
Fisso-alzante-scorrevole-fisso C9V001-C9K020 - Superiore.....	H.1.19
Fisso-alzante-scorrevole-fisso C9V001-C9K020 - Centrale.....	H.1.20
Rinforzo interno - 1 anta.....	H.1.21
Rinforzo interno - 2 ante.....	H.1.22

### I DISTINTE DI TAGLIO

### J FERRAMENTA & DISEGNI

## ASSEMBLAGGIO

<b>Direttive generali</b> .....	J.1.1		
Assemblaggio generale - e specifiche di montaggio in officina ...			
J.1.1			
Drenaggio "lato bagnato".....	J.1.1		
<b>2-binari telaio tagli 45°</b> .....	J.2.1		
Panoramica assemblaggio.....	J.2.2		
Contenuto.....	J.2.3		
Operazioni C9K020 + KU2028 e assemblaggio BT6006.....	J.2.4		
Lavorazione squadrette per C9K020.....	J.2.5		
Operazioni C9K020 per cappetta di drenaggio.....	J.2.6		
C9K020 + KU2028 panoramica drenaggi.....	J.2.7		
C9K020 lavorazione drenaggio - J (optional 1/2).....	J.2.8		
C9K020 lavorazione drenaggio - J (optional 2/2).....	J.2.9		
C9K020 lavorazione drenaggio - H.....	J.2.10		
C9K020 lavorazione drenaggio - B.....	J.2.11		
C9K020 lavorazione drenaggio - A.....	J.2.12		
C9K020 lavorazione drenaggio - G.....	J.2.13		
C9K020 lavorazione drenaggio - M.....	J.2.14		
KU2028 lavorazione drenaggio - K1.....	J.2.15		
KU2028 lavorazione drenaggio - K2.....	J.2.16		
Assemblaggio VS0107 e KU2028 su C9K020 profilato inferiore C9K020.....	J.2.17		
J.2.18			
Sigillatura profilato inferiore C9K020 con VS9950 e VS9951.....			
J.2.20			
Assemblaggio tappo centrale CO1111 profilato superiore C9K020			
J.2.21			
Assemblaggio punti di chiusura - ZB0034/ZB0035/ZB0036.....	J.2.22		
Assemblaggio profilati telai con squadrette.....	J.2.23		
Assemblaggio cappetta di drenaggio C9A003.....	J.2.26		
Operazioni C9A004 + VS2404.....	J.2.27		
Assemblaggio C9A004 + VS2404.....	J.2.28		
Assemblaggio C9A004 + VS2404 - optional.....	J.2.29		
Assemblaggio CO1103.....	J.2.30		
Assemblaggio CO1103 con 1 anta funzionale.....	J.2.31		
Assemblaggio CO1103 e ZB0038 per schema 4 ante.....	J.2.32		
Assemblaggio punti di chiusura.....	J.2.33		
Assemblaggio guarnizione di finitura RU9704.....	J.2.34		
Assemblaggio tappo centrale CO1105/CO1104 profilato inferiore C9K020.....	J.2.35		
<b>2-binari telaio tagli 90°</b> .....	J.3.1		
Panoramica assemblaggio.....	J.3.2		
Contenuto.....	J.3.3		
Operazioni C9K121 e assemblaggio BT6019.....	J.3.4		
Operazioni C9K121 per assemblaggio telaio.....	J.3.5		
Operazioni C9K120 + KU2028 e assemblaggio BT6006.....	J.3.6		
Operazioni C9K120 per cappetta di drenaggio.....	J.3.7		
C9K120 e KU2028 panoramica drenaggi.....	J.3.8		
C9K120 lavorazione drenaggio - J (optional 1/2).....	J.3.9		
C9K120 lavorazione drenaggio - H.....	J.3.11		
C9K120 lavorazione drenaggio - B.....	J.3.12		
C9K120 lavorazione drenaggio - A.....	J.3.13		
C9K120 lavorazione drenaggio - G.....	J.3.14		
C9K120 lavorazione drenaggio - M.....	J.3.15		
KU2028 lavorazione drenaggio - K1.....	J.3.16		
KU2028 lavorazione drenaggio - K2.....	J.3.17		
Assemblaggio VS0107 e KU2028 su C9K020 profilato inferiore C9K120.....	J.3.18		
J.3.19			
Assemblaggio tappo centrale CO1105 profilato inferiore C9K120			
J.3.21			
Assemblaggio cappetta di drenaggio C9A003.....	J.3.22		
Operazioni C9A004.....	J.3.23		
Assemblaggio C9A004.....	J.3.24		
Assemblaggio CO0132 e VS9957 su C9K121.....	J.3.25		
Assemblaggio VS9999 su C9K121 e assemblaggio telaio.....	J.3.26		
Sigillatura C9A004.....	J.3.27		
Assemblaggio punti di chiusura (ZB0034/ZB0035/ZB0036).....	J.3.28		
Assemblaggio RU9704.....	J.3.29		
Assemblaggio C9A100.....	J.3.30		
Assemblaggio KU2035.....	J.3.31		
J.1.4 Assemblaggio CO1103.....	J.3.32		
Assemblaggio CO1103 con 1 anta funzionale.....	J.3.33		
Assemblaggio CO1103 e ZB0038 per schema 4 ante.....	J.3.34		
Assemblaggio punti di chiusura.....	J.3.35		
Assemblaggio guarnizione di finitura RU9704.....	J.3.36		
Assemblaggio tappo centrale CO1105/CO1104 profilato inferiore C9K120.....	J.3.37		
<b>3-binari telaio tagli 45°</b> .....	J.4.1		
Panoramica assemblaggio.....	J.4.2		
Contenuto.....	J.4.3		
Operazioni C9K030 + KU2028 e assemblaggio BT6006.....	J.4.4		
Operazioni squadrette per C9K030.....	J.4.5		
Operazioni C9K030 per cappetta di drenaggio C9A003.....	J.4.7		
C9K030 panoramica drenaggi.....	J.4.8		
KU2028 panoramica drenaggi.....	J.4.9		
C9K030 lavorazione drenaggio - J.....	J.4.10		
C9K030 lavorazione drenaggio - H1, H2.....	J.4.11		
C9K030 lavorazione drenaggio - B, D.....	J.4.12		
C9K030 lavorazione drenaggio - A, C.....	J.4.13		
C9K030 lavorazione drenaggio - G.....	J.4.14		
C9K030 lavorazione drenaggio - M.....	J.4.15		
KU2028 lavorazione drenaggio - K1, K2.....	J.4.16		
KU2028 lavorazione drenaggio - K3.....	J.4.17		
KU2028 lavorazione drenaggio - K4.....	J.4.18		
KU2028 lavorazione drenaggio - K5.....	J.4.19		
Assemblaggio VS0107 e KU2028 su C9K020 profilato inferiore J.4.20			
Assemblaggio tappo centrale CO1105 profilato inferiore C9K030			
J.4.21			
Assemblaggio tappo centrale CO1105/CO1104 profilato inferiore C9K030.....	J.4.22		
Sigillatura profilato inferiore C9K030 con VS9950/VS9951/VS9964 e VS9965.....	J.4.23		
Assemblaggio tappo centrale CO1111 profilato superiore C9K030			
J.4.24			
Assemblaggio profilati telai con squadrette.....	J.4.27		
Assemblaggio cappetta di drenaggio C9A003.....	J.4.30		
Operazioni C9A004 + VS2404.....	J.4.31		
Assemblaggio C9A004 + VS2404.....	J.4.32		
Assemblaggio C9A004 + VS2404 - optional.....	J.4.33		
Assemblaggio CO1103.....	J.4.34		
Assemblaggio CO1103 per fisso-scorrevole-fisso.....	J.4.35		
Assemblaggio CO1103 e ZB0038 per schema 4 ante.....	J.4.36		
Assemblaggio punti di chiusura.....	J.4.37		
Assemblaggio guarnizione di finitura RU9704.....	J.4.38		
Assemblaggio tappo centrale CO1105/CO1104 profilato inferiore C9K030.....	J.4.39		
<b>2-binari fisso-alzante-scorrevole-fisso tagli 45°</b> .....	J.5.1		
Panoramica assemblaggio.....	J.5.2		
Contenuto.....	J.5.3		
Operazioni C9K020 + KU2028 e assemblaggio BT6006.....	J.5.4		
Lavorazione squadrette per C9K020.....	J.5.5		
Operazioni cappetta di drenaggio.....	J.5.6		
C9K020 + KU2028 panoramica drenaggi.....	J.5.7		
C9K020 lavorazione drenaggio - J (optional 1/2).....	J.5.8		
C9K020 lavorazione drenaggio - J (optional 2/2).....	J.5.9		
C9K020 lavorazione drenaggio - H.....	J.5.10		
C9K020 lavorazione drenaggio - B.....	J.5.11		
C9K020 lavorazione drenaggio - A.....	J.5.12		
C9K020 lavorazione drenaggio - G.....	J.5.13		
C9K020 lavorazione drenaggio - M.....	J.5.14		
KU2028 lavorazione drenaggio - K1.....	J.5.15		
KU2028 lavorazione drenaggio - K2.....	J.5.16		
KU2028 lavorazione drenaggio - K3.....	J.5.17		

## CONTENUTO

Assemblaggio VS0107 e KU2028 su C9K020 profilato inferiore	J.5.18	Contenuto	J.8.1
Assemblaggio tappo centrale CO1105 profilato inferiore	J.5.19	Ferramenta alzante-scorrevole panoramica	J.8.2
Sigillatura profilato inferiore C9K020 con VS9950 e VS9951	J.5.21	Assemblaggio CO2206	J.8.3
Assemblaggio tappo centrale CO1111 profilato superiore C9K020	J.5.22	Preparazione ZB0033/ZB0034/ZB0035/ZB0036	J.8.4
Assemblaggio profilati telai con squadrette	J.5.23	Preparazione chiusura meccanismo alzante-scorrevole	J.8.5
Assemblaggio cappetta di drenaggio C9A003	J.5.26	Installazione ZB0033/ZB0034/ZB0035/ZB0036 - no maniglia esterna opzioni	J.8.6
Preparazione C9A004 + VS2404	J.5.27	Assemblaggio ZB0053/ZB0054 - optional	J.8.7
Assemblaggio C9A004 + VS2404	J.5.28	Preparazione ZB0046	J.8.8
Assemblaggio C9A004 + VS2404 cover - optional	J.5.29	Assemblaggio ZB0035/ZB0036 con ZB0046	J.8.9
Assemblaggio CO11103 e ZB0038	J.5.30	Assemblaggio ZB0035/ZB0036/ZB0046 con ZB0048 e ZB0049/ZB0050	J.8.10
Assemblaggio guarnizione di finitura RU9704	J.5.31	Assemblaggio ZB0048 con ZB0049/ZB0050	J.8.11
Assemblaggio tappo centrale CO1105 profilato inferiore	J.5.32	Assemblaggio ZB0035/ZB0036/ZB0046 con ZB0048	J.8.12
<b>Preparazione ante</b>	<b>J.6.1</b>	Installazione chiusura meccanismo alzante-scorrevole	J.8.13
Panoramica assemblaggio	J.6.1	Installazione chiusura meccanismo alzante-scorrevole - anta passiva schema 4 ante	J.8.15
Contenuto	J.6.2	<b>Rinforzo anta - optional</b>	<b>J.9.1</b>
Taglio profilati anta e installazione BT6000	J.6.3	Contenuto	J.9.1
Lavorazione squadrette profilati ante	J.6.4	Installazione blocco supporto VS5132 e RU9094	J.9.2
Lavorazione del C9V051 profilato anta effetto 'bi-metal'	J.6.6	Installazione C9C001	J.9.3
Lavorazione drenaggio profilata anta	J.6.7	Lato ferramenta alzante-scorrevole - Installazione RU9094	J.9.4
Panoramica lavorazione paracolpi su profilato anta	J.6.8	Lato ferramenta alzante-scorrevole - preparazione C9C001	J.9.5
Lavorazione paracolpi su profilato anta	J.6.9	Lato ferramenta alzante-scorrevole - Installazione C9C001	J.9.6
Lavorazione profilato anta per tappo 1/2	J.6.10	<b>Assemblaggio accessori anta</b>	<b>J.10.1</b>
Lavorazione profilato anta per ferramenta alzante-scorrevole - panoramica	J.6.11	Contenuto	J.10.1
Lavorazione profilato anta per ferramenta alzante-scorrevole - panoramica	J.6.14	Assemblaggio distanziale VS5131	J.10.2
Lavorazione profilato anta per ferramenta alzante-scorrevole	J.6.16	Lavorazione profilato anta inserimento tappo terminali	J.10.3
Installazione guranizione RU0099 per alzante-scorrevole	J.6.20	Anta standard - installazione VS9149 e RU9094	J.10.4
Installazione guranizione RU0099 per alzante-scorrevole - 3-binari	J.6.21	Anta standard - preparazione labirinto	J.10.5
Assemblaggio profilato anta con squadrette	J.6.23	Anta standard - assemblaggio labirinto	J.10.6
<b>Assemblaggio ferramenta anta</b>	<b>J.7.1</b>	Anta standard - installazione BT6013 e C9A001/C9A002	J.10.7
Contenuto	J.7.1	3-binari alzante-scorrevole lato ferramenta - assemblaggio VS9149 e RU9094	J.10.8
Ferramenta alzante-scorrevole - panoramica	J.7.2	3-binari alzante-scorrevole lato ferramenta - preparazione labirinto	J.10.9
Preparazione carrelli alzante-scorrevole	J.7.3	3-binari alzante-scorrevole lato ferramenta - assemblaggio labirinto	J.10.10
Preparazione carrelli alzante-scorrevole (300 - 400 kg)	J.7.5	3-binari alzante-scorrevole lato ferramenta - assemblaggio C9A001/C9A002	J.10.11
Preparazione ZB0033/ZB0034/ZB0035/ZB0036	J.7.12	Fisso-alzante-scorrevole-fissoi lato ferramenta - VS9211 e RU9094	J.10.12
Preparazione ZB0033/ZB0034/ZB0035/ZB0036 - maniglia interna	J.7.13	Fisso-alzante-scorrevole-fissoi lato ferramenta - labirinto	J.10.13
Assemblaggio ZB0053/ZB0054 - sollevamento servo assistito	J.7.14	Fisso-alzante-scorrevole-fissoi lato ferramenta - assemblaggio labirinto	J.10.14
Preparazione ZB0046	J.7.15	Fisso-alzante-scorrevole-fissoi lato ferramenta - assemblaggio C9A007	J.10.15
Assemblaggio ZB0035/ZB0036 con ZB0046	J.7.16	Fisso-alzante-scorrevole-fissoi lato ferramenta - assemblaggio RU9009	J.10.16
Assemblaggio meccanismo chiusura alzante-scorrevole	J.7.17	Fisso-alzante-scorrevole-fissoi lato ferramenta	J.10.17
Assemblaggio meccanismo chiusura alzante-scorrevole - anta passiva schema 4 ante	J.7.18	Anta passiva schema 4 ante - preparazione RU0099	J.10.22
Installazione maniglia interna standard alzante-scorrevole	J.7.19	Anta passiva schema 4 ante - preparazione C9C002	J.10.23
Installazione maniglia interna standard e vaschetta esterna alzante-scorrevole	J.7.20	Anta passiva schema 4 ante - installazione tappo sigillatura inferiore	J.10.26
Installazione maniglia interna standard con mezzo cilindro alzante-scorrevole	J.7.21	Anta passiva schema 4 ante - Installazione punti di chiusura	J.10.27
Maniglia interna standard con mezzo cilindro e vaschetta alzante-scorrevole	J.7.22	Anta passiva schema 4 ante - installazione tappo sigillatura superiore	J.10.28
Installazione maniglia standard su due lati con cilindro alzante-scorrevole	J.7.23	<b>Installazione ante su telai</b>	<b>J.11.1</b>
Installazione maniglia interna S-line Harmony alzante-scorrevole	J.7.24	Contenuto	J.11.1
Maniglia interna S-line Harmony e vaschetta esterna alzante-scorrevole	J.7.25	2-binari	J.11.2
Installazione maniglia interna S-line Harmony con mezzo cilindro alzante-scorrevole	J.7.26	3-binari	J.11.3
Maniglia interna S-line Harmony con mezzo cilindro e vaschetta alzante-scorrevole	J.7.27	Uso standard	J.11.6
Installazione maniglia S-Line Harmony su due lati con cilindro alzante-scorrevole	J.7.28	Aggiustamenti	J.11.6
<b>Assemblaggio ferramenta anta - RC2</b>	<b>J.8.1</b>	Anta fissa scorrevole-fisso - VS5128/VS5129	J.11.6
		Anta fissa scorrevole-fisso - assemblaggio VS5128 e BT6015	J.11.7
		Anta fissa scorrevole-fisso - fori per guide	J.11.8
		Scorrevole-fisso - VS5129 e BT6026	J.11.9
		Scorrevole-fisso - assemblaggio anta fissa su telai	J.11.10

Scorrevole-fisso - rimozione profilato cartellina.....	J.11.11
Scorrevole-fisso - assemblaggio BT6026 e VS5129 superiore ...	
J.11.12	
Scorrevole-fisso - fissaggio con SCZ617.....	J.11.13
Scorrevole-fisso - fissaggio con SCZ617.....	J.11.14
Scorrevole-fisso - base tappo di tenuta e cartellina anta J.11.15	
Scorrevole-fisso - posizionamento anta apribile sul telaio J.11.16	
Assemblaggio tappo di tenuta superiore- 2-binari telai....	J.11.17
Assemblaggio tappo di tenuta superiore- 3-binari telai....	J.11.18
Assemblaggio SV9002.....	J.11.19
<b>Operazioni finitura ante.....</b>	<b>J.12.1</b>
Contenuto.....	J.12.1
Anta passiva schema 4 ante - tappo di tenuta.....	J.12.2
Anta passiva schema 4 ante - fissaggio tappo di tenuta...	J.12.3
Anta passiva schema 4 ante - posizionamento incontri di chiusura	
J.12.4	
Anta passiva schema 4 ante - installazione guarnizione di finitura	
RU9704.....	J.12.5
Inserimento finale tappo di tenuta ante alzante-scorrevole J.12.6	
Inserimento finale tappo di tenuta ante alzante-scorrevole - Spe-	
ciale 3-binari.....	J.12.7
Inserimento finale tappo di tenuta ante alzante-scorrevole - Spe-	
ciale.....	J.12.8
<b>Vetratura ante.....</b>	<b>J.13.1</b>
Installazione supporto vetri VS5126 sull'anta.....	J.13.1
Lavorazione fermavetri per uso con VS5126.....	J.13.2
Vetratura versione SHI con RU0002/RU0004.....	J.13.3
Angolo galleggiante.....	J.14.1
Panoramica - Interno.....	J.14.1
2-binari - Operazioni telaio.....	J.14.2
2-binari - Assemblaggio telaio.....	J.14.3
Operazioni C9C003.....	J.14.8
Operazioni RB0086.....	J.14.10
Operazioni C9V001.....	J.14.11
Assemblaggio C9C003 + CO1102 + RU4033.....	J.14.13
Assemblaggio C9C003 + SF212x.....	J.14.14
Assemblaggio C9C003 + RB0086 + SF36x.....	J.14.15
Operazioni - Interno.....	J.14.16
Rallentatore Chiusura.....	J.14.16A
<b>Pagine di riferimento rapido.....</b>	<b>J.15.1</b>
Ferramenta alzante-scorrevole.....	J.15.1
2-binari drenaggio.....	J.15.5
3-binari drenaggio.....	J.15.6

## K ALLEGATI

Limiti di impiego - alzante-scorrevole.....	K.1.1
2 ante con C9V001.....	K.1.1
2 ante con C9V051.....	K.1.2
4 ante.....	K.1.3
Valore Uf di finestre e porte.....	K.2.1

210-003	E.3.1	KU2028	E.4.5
213-006	E.3.2	KU2029	E.4.5
39R506	E.3.1	KU5001	E.4.1
39R507	E.3.1	KU6004	E.3.4
39R508	E.3.1	RU0002	E.3.1
52A28	B.6.1	RU0004	E.3.1
71C011	E.2.1	RU0099	E.3.4
71P003	E.4.3	RU4033	E.3.5
71R200	E.3.3	RU9022	E.3.3
778-500	E.2.1	RU9079	E.3.4
82L538	F.1.8	RU9094	E.3.5
BT6000	E.4.1	RU9095	E.3.2
BT6006	E.4.2	RU9136	E.3.5
BT6013	E.4.5	RU9703	E.3.4
BT6015	E.4.5	RU9704	E.3.4
BT6019	E.4.2	SCG641	E.4.11
BT6026	E.4.6	SCZ003	E.2.1
BT6027	E.4.6	SCZ810	E.2.1
C9A001	B.5.1	SF2127	F.2.5
C9A002	B.5.1	SF2129	F.2.5
C9A003	B.6.2	SF3066	F.2.6
C9A004	B.6.1	SF3068	F.2.6
C9A100	B.8.2	SF3925	F.2.1
C9C001	B.4.1	SF8018	F.2.1
C9C002	B.7.1	SV0032	F.2.4
C9C003	B.7.2	SV9002	F.2.2
C9K020	B.2.1	TG4116	G.2.2
C9K030	B.2.3	VS0107	E.4.6
C9K120	B.2.2	VS1132	E.4.11
C9K121	B.2.2	VS2404	E.4.9
C9V001	B.3.1	VS5126	E.4.1
C9V051	B.3.2	VS5128	E.4.4
CO0132	E.4.9	VS5129	E.4.4
CO1103	E.4.6	VS5131	E.4.4
CO1105	E.4.6	VS5132	E.4.4
CO1107	E.4.7	VS5135	E.4.11
CO1110	E.4.7	VS5142	E.4.1
CO1111	E.4.7	VS8001	E.4.11
CO1118	E.4.10	VS8002	E.4.11
CO1125	E.4.10	VS9148	E.4.9
CO1127	E.4.6	VS9149	E.4.9
CO1214	E.4.7	VS9163	E.4.10
CO2181	B.8.1	VS9211	E.4.10
CO2206	B.8.1	VS9950	E.4.7
CO2211	E.4.10	VS9951	E.4.8
CO2251	E.4.11	VS9956	E.4.8
CO2279	E.4.3	VS9957	E.4.9
CYL102	F.2.1	VS9964	E.4.8
CYL318	F.2.1	VS9965	E.4.8
D4074009	E.4.5	VS9999	E.4.8
DHA020	F.2.4	Z9A016	C.1.1
GC0303	D.2.1	Z9C005	C.1.1
GC0307	D.2.1	Z9C030	C.1.1
GC2310	D.2.1	ZB0024	F.2.2
GC2312	D.2.1	ZB0025	F.2.2
GC2315	D.2.1	ZB0027	F.2.3
GC2317	D.2.1	ZB0028	F.2.3
GC2320	D.2.1	ZB0029	F.2.4
GC2322	D.2.1	ZB0030	F.2.4
GC2325	D.2.1	ZB0031	F.2.4
GC2327	D.2.1	ZB0032	F.2.4
GC2330	D.2.1	ZB0033	F.2.4
HLH301	F.2.3	ZB0034	F.2.4
HLH302	F.2.3	ZB0035	F.2.5
HLH304	F.2.3	ZB0036	F.2.5
HV0G03	E.1.2	ZB0038	F.1.8
HV2W11	E.1.1	ZB0038	F.2.2
HV3H26	E.1.2	ZB0040	F.2.2
HV4K00	E.2.2	ZB0045	F.2.1
HV4K01	E.2.2	ZB0046	F.2.5
KU2027	E.4.4		





**Informazioni sistema**



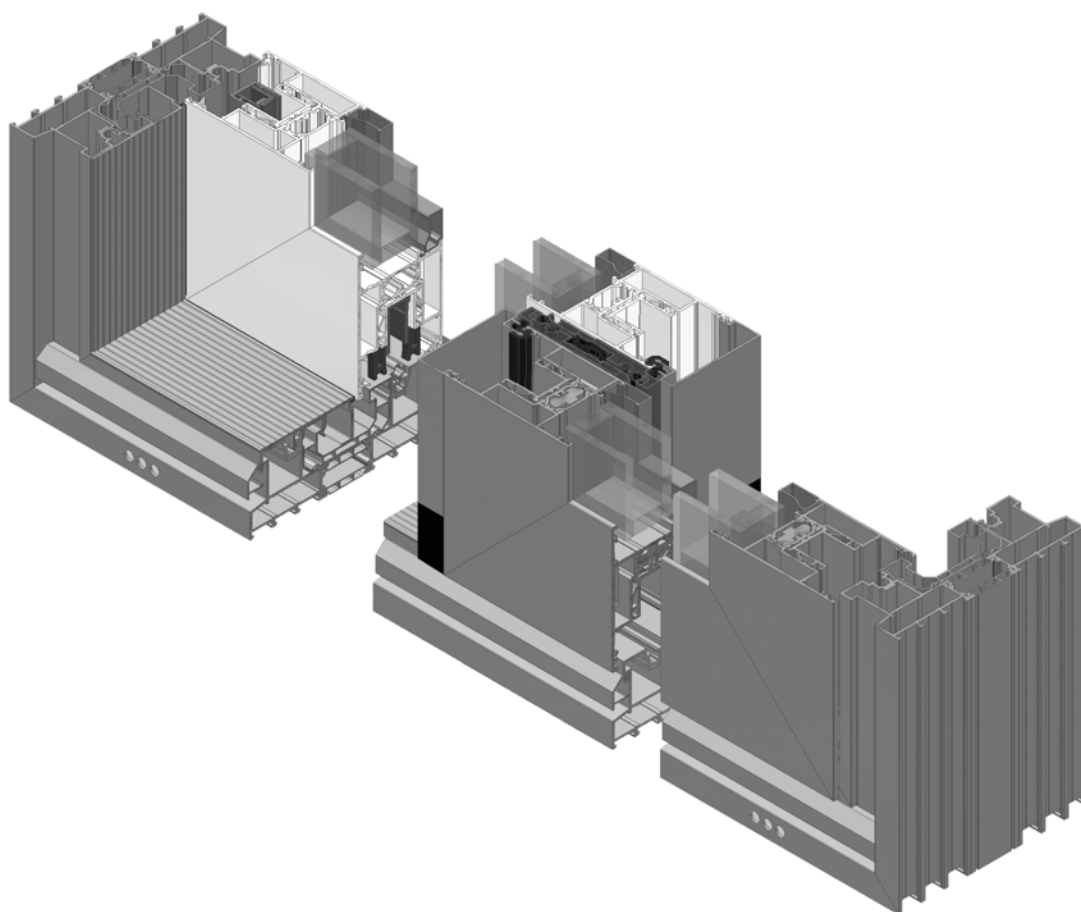

<b>Prodotto:</b>	Sistema termicamente isolato per finestre e porte
<b>Applicazioni / uso:</b>	Parti trasparenti e opache della facciata esterna per le esigenze più elevate.
<b>Possibilità:</b>	Adatto per ambienti riscaldati e per tutti i tipi di edifici. Secondo la norma di prodotto EN 14351-1-.
<b>Funzioni:</b>	Protezione dal calore, protezione climatica, protezione acustica, ventilazione.
<b>Dimensioni telaio:</b>	160 mm
<b>Dimensioni ante:</b>	70 mm
<b>Altezza nodi:</b>	Telaio + anta: 149-159 mm, centrale: 126 mm.
<b>Riempimenti:</b>	Tutti i tipi di riempimenti trasparenti e opachi da 5 fino a 53 mm.
<b>Tipi di apertura:</b>	

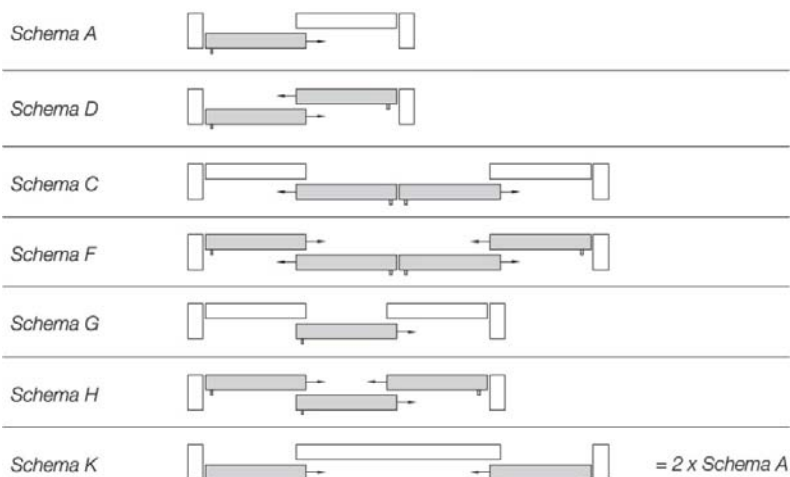

<b>Superfici:</b>	Verniciate a polvere o anodizzate.
<b>Drenaggio:</b>	Cappetta di drenaggio sulla parte bassa del telaio o drenaggio nascosto.
<b>Ulteriori possibilità:</b>	Resistenza all'effrazione RC2

**2-BINARI**





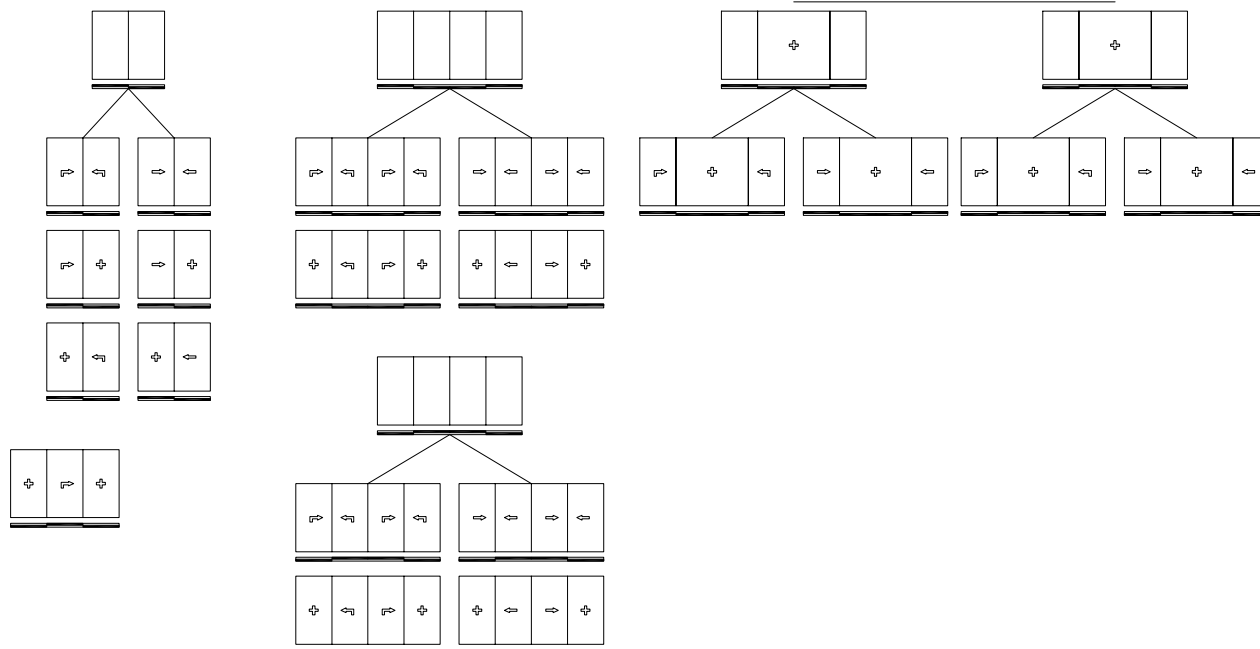

**Opzioni:** Sistema modulare per miglioramento termico secondo le necessità.  
 Profilati di finitura.  
 Profilati di rinforzo.

**Opzioni ferramenta:** Scelta di diverse maniglie. Vedi capitolo ferramenta.

**Varianti configurazioni:**



**Performance:**

Test	Risultati		Norme
 Isolamento termico	sagoma omega PA 6.6 GF25 di 35 mm		
	ATG 11/H772 - ATG 11/H730		
	I: $U_f = 2.8 - 3.4 \text{ W/m}^2\text{K}$		EN ISO 10077-1
	SI: $U_f = 2.6 - 3.2 \text{ W/m}^2\text{K}$		EN ISO 10077-1
	SHI: $U_f = 2.09 - 3.1 \text{ W/m}^2\text{K}$		EN ISO 10077-1
 Permeabilità aria	4	600 Pa	EN 12207
 Tenuta acqua	E1200	1200 Pa	EN 12208
 Resistenza vento	C4	1600 Pa	EN12210
 Test acustici	$R_w(C;Ctr) = 42(-1;-4) \text{ dB}$ con vetro $R_w(C;Ctr) = 50(-2;-5) \text{ dB}$		EN ISO 717/1
 Resistenza all'effrazione	Classe 2		ENV 1627 - 1630
 Sforzo apertura	Classe 1		EN 13115

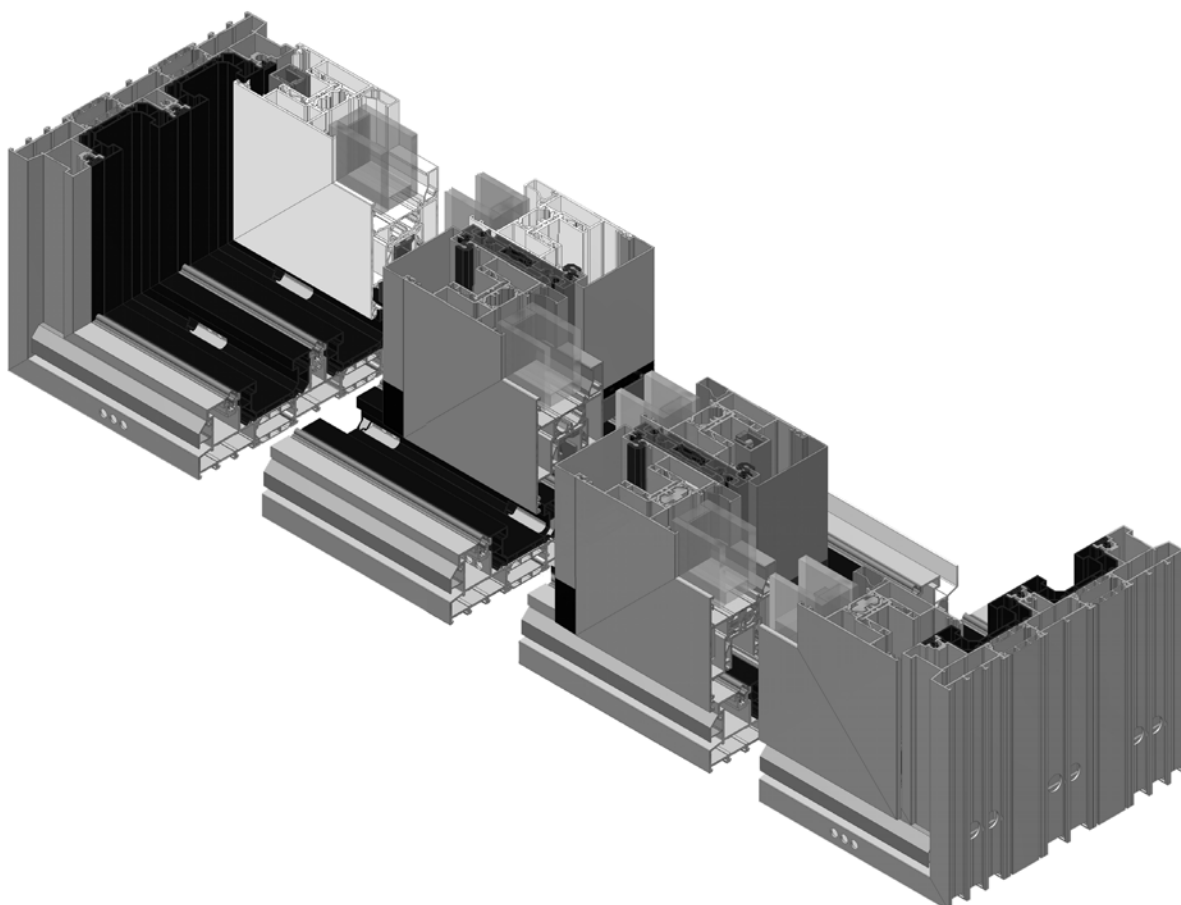

<b>Prodotto:</b>	Sistema termicamente isolato per finestre e porte
<b>Applicazioni / uso:</b>	Parti trasparenti e opache della facciata esterna per le esigenze più elevate.
<b>Possibilità:</b>	Adatto per ambienti riscaldati e per tutti i tipi di edifici. Secondo la norma di prodotto EN 14351-1-.
<b>Funzioni:</b>	Protezione dal calore, protezione climatica, protezione acustica, ventilazione.
<b>Dimensioni telaio:</b>	250 mm
<b>Dimensioni anta:</b>	70 mm
<b>Altezza nodi:</b>	Telaio + anta: 149-159 mm, centrale: 126 mm.
<b>Riempimenti:</b>	Tutti i tipi di riempimenti trasparenti e opachi da 5 fino a 53 mm.
<b>Tipi di apertura:</b>	

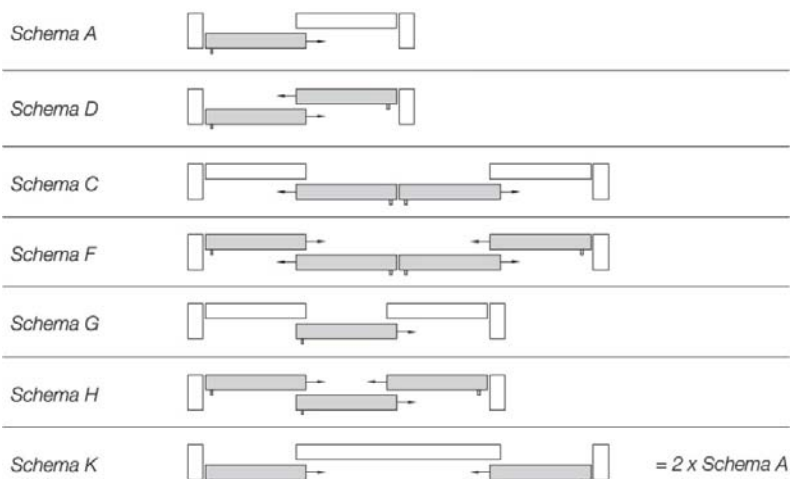

<b>Superfici:</b>	Verniciate o anodizzate.
<b>Drenaggio:</b>	Cappetta di drenaggio sulla parte bassa del telaio o drenaggio nascosto.
<b>Ulteriori possibilità:</b>	Resistenza all'effrazione RC2





**Opzioni:** Sistema modulare per miglioramento termico secondo le necessità.  
 Profilati di finitura.  
 Profilati di rinforzo.

**Opzioni ferramenta:** Scelta di diverse maniglie. Vedi capitolo ferramenta.

**Varianti configurazioni:**



**Performance:**

Test	Risultati		Norme	
	sagoma omega PA 6.6 GF25 di 35 mm			
	ATG 11/H772 - ATG 11/H730			
	Isolamento termico	I: $U_f = 2.8 - 3.4 \text{ W/m}^2\text{K}$		EN ISO 10077-1
		SI: $U_f = 2.6 - 3.2 \text{ W/m}^2\text{K}$		EN ISO 10077-1
		SHI: $U_f = 2.09 - 3.1 \text{ W/m}^2\text{K}$		EN ISO 10077-1
	Permeabilità aria	4	600 Pa	EN 12207
	Tenuta acqua	E900	900 Pa	EN 12208
	Resistenza vento	C4	1600 Pa	EN12210

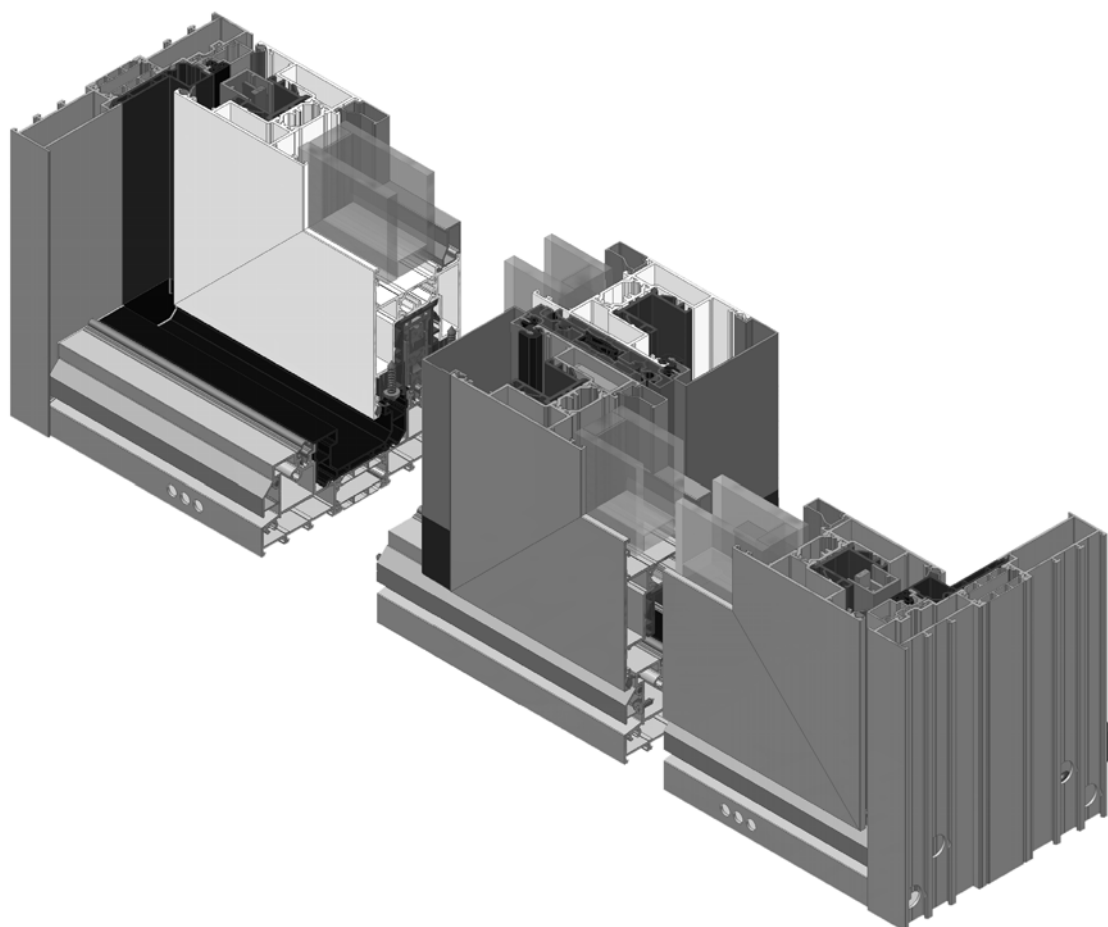

<b>Prodotto:</b>	Sistema termicamente isolato per finestre e porte
<b>Applicazioni / uso:</b>	Parti trasparenti e opache della facciata esterna per le esigenze più elevate.
<b>Possibilità:</b>	Adatto per ambienti riscaldati e per tutti i tipi di edifici. Secondo la norma di prodotto EN 14351-1-.
<b>Funzioni:</b>	Protezione dal calore, protezione climatica, protezione acustica, ventilazione.
<b>Dimensione telaio:</b>	160 mm
<b>Dimensione anta:</b>	70 mm
<b>Altezza nodi:</b>	Telaio + anta: 138-143 mm, centrale: 126 mm.
<b>Riempimenti:</b>	Tutti i tipi di riempimenti trasparenti e opachi da 5 fino a 53 mm.
<b>Tipi di apertura:</b>	

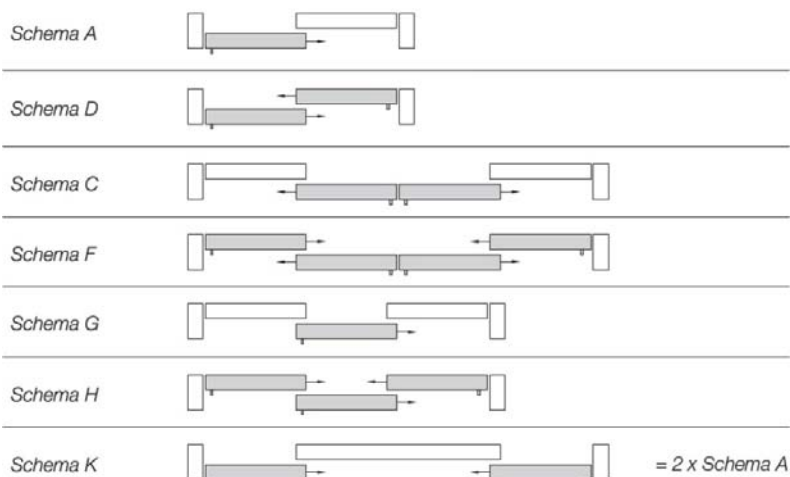

<b>Superfici:</b>	Verniciate a polvere o anodizzate.
<b>Drenaggio:</b>	Cappetta di drenaggio sulla parte bassa del telaio o drenaggio nascosto.
<b>Ulteriori possibilità:</b>	Resistenza all'effrazione RC2



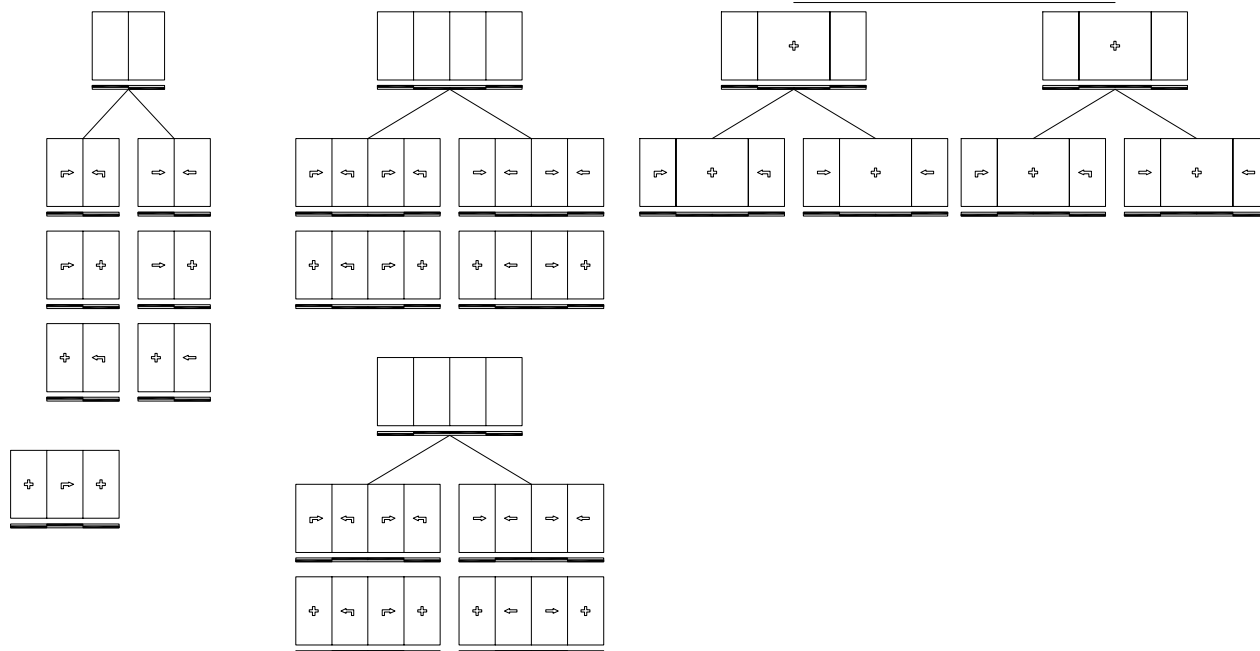

**Opzioni:** Sistema modulare per miglioramento termico secondo le necessità.  
 Profili di finitura.  
 Profili di rinforzo.

**Opzioni ferramenta:** Scelta di diverse maniglie. Vedi capitolo ferramenta.

**Varianti configurazioni:**



**Performance:**

Test	Risultati		Norme
 Isolamento termico	sagoma omega PA 6.6 GF25 di 35 mm		
	ATG 11/H772 - ATG 11/H730		
	I: $U_f = 2.8 - 3.4 \text{ W/m}^2\text{K}$		EN ISO 10077-1
	SI: $U_f = 2.6 - 3.2 \text{ W/m}^2\text{K}$		EN ISO 10077-1
	SHI: $U_f = 2.09 - 3.1 \text{ W/m}^2\text{K}$		EN ISO 10077-1
 Permeabilità aria	4	600 Pa	EN 12207
 Tenuta acqua	E1350	1350 Pa	EN 12208
 Resistenza vento	C4	1600 Pa	EN12210
 Sforzo apertura	Classe 1		EN 13115



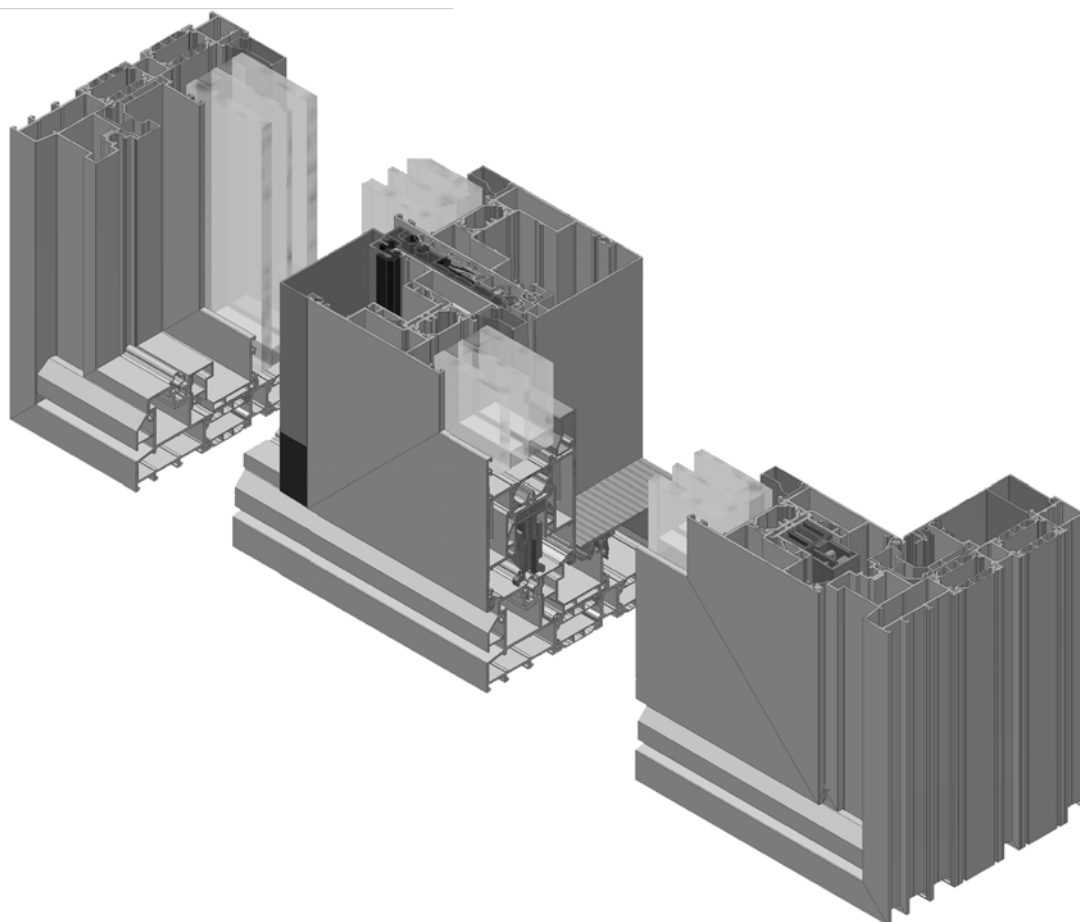

<b>Prodotto:</b>	Sistema termicamente isolato per finestre e porte
<b>Applicazioni / uso:</b>	Parti trasparenti e opache della facciata esterna per le esigenze più elevate.
<b>Possibilità:</b>	Adatto per ambienti riscaldati e per tutti i tipi di edifici. Secondo la norma di prodotto EN 14351-1-.
<b>Funzioni:</b>	Protezione dal calore, protezione climatica, protezione acustica, ventilazione.
<b>Dimensioni telaio:</b>	160 mm
<b>Dimensioni ante:</b>	70 mm
<b>altezza nodi:</b>	Fisso: 53-60, telaio + anta: 143-159 mm, centrale: 126 mm.
<b>Riempimenti:</b>	Tutti i tipi di riempimenti trasparenti e opachi da 5 fino a 53 mm.
<b>Tipi di apertura:</b>	

Schema A

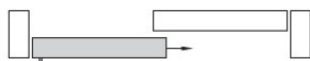

Schema C



Schema G



Schema K







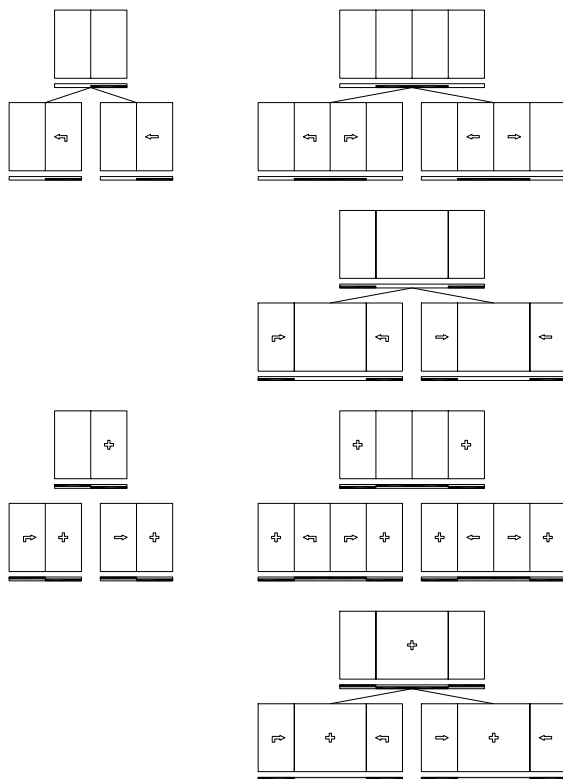

<b>Superfici:</b>	Verniciate a polvere o anodizzate.
<b>Drenaggio:</b>	Cappetta di drenaggio sulla parte bassa del telaio o drenaggio nascosto.
<b>Ulteriori possibilità:</b>	Resistenza all'effrazione RC2
<b>Opzioni:</b>	Sistema modulare per miglioramento termico secondo le necessità. Profilati di finitura. Profilati di rinforzo.
<b>Opzioni ferramenta:</b>	Scelta di diverse maniglie. Vedi capitolo ferramenta.

Varianti configurazioni:



Performance:

Test	Risultati		Norme	
	Isolamento termico	sagoma omega PA 6.6 GF25 di 35 mm		
		ATG 11/H772 - ATG 11/H730		
		I: $U_f = 2.8 - 3.4 \text{ W/m}^2\text{K}$		EN ISO 10077-1
		SI: $U_f = 2.6 - 3.2 \text{ W/m}^2\text{K}$		EN ISO 10077-1
		SHI: $U_f = 2.09 - 3.1 \text{ W/m}^2\text{K}$		EN ISO 10077-1
	Permeabilità aria	4	600 Pa	EN 12207
	Tenuta acqua	9A	600 Pa	EN 12208
	Resistenza vento	C4	1600 Pa	EN12210
	Test acustici	$R_w(C;Ctr) = 43(-1;-4) \text{ dB}$ con vetro $R_w(C;Ctr) = 50(-2;-5) \text{ dB}$		EN ISO 717/1
	Resistenza all'effrazione	Classe 2		ENV 1627 - 1630
	Sforzo apertura	Classe 1		EN 13115

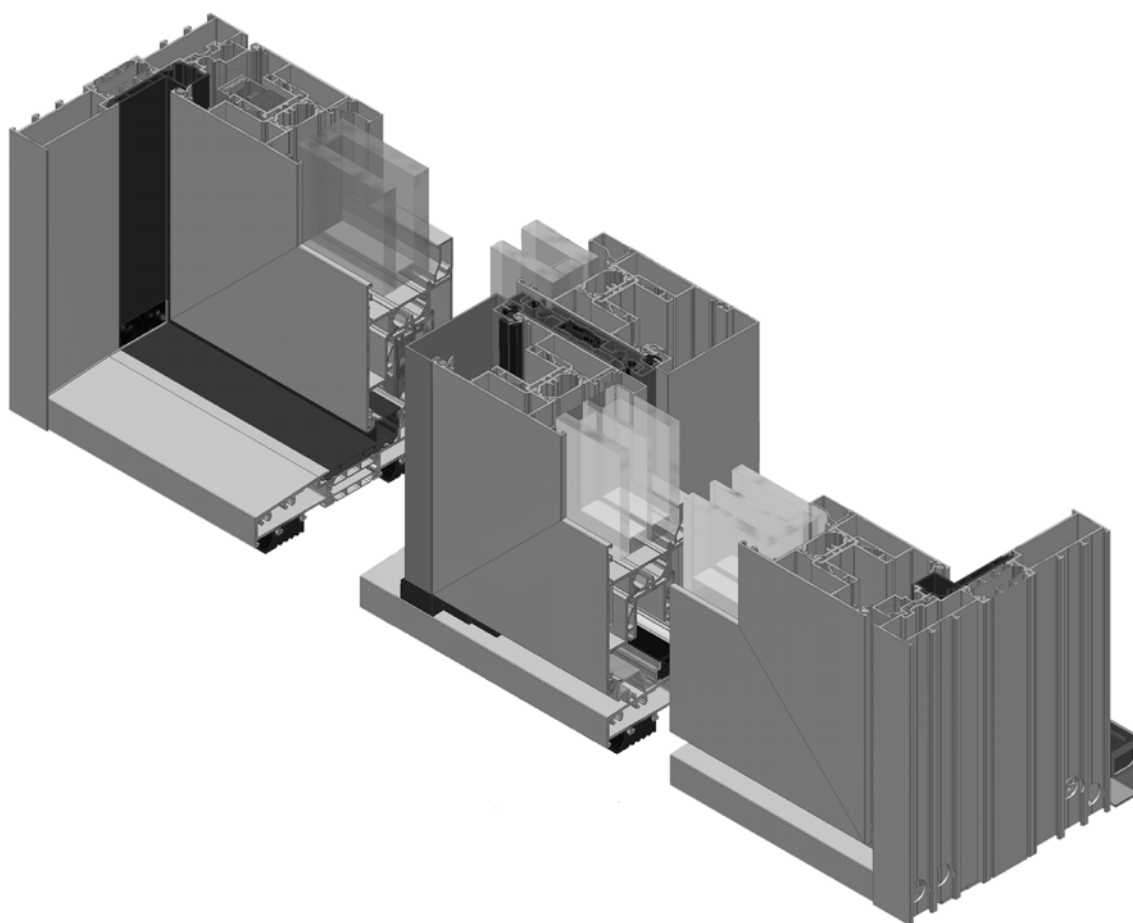

<b>Prodotto:</b>	Sistema termicamente isolato per finestre e porte
<b>Applicazioni / uso:</b>	Parti trasparenti e opache della facciata esterna per le esigenze più elevate.
<b>Possibilità:</b>	Adatto per ambienti riscaldati e per tutti i tipi di edifici. Secondo la norma di prodotto EN 14351-1-.
<b>Funzioni:</b>	Protezione dal calore, protezione climatica, protezione acustica, ventilazione.
<b>Dimensioni telaio:</b>	160 mm
<b>Dimensioni ante:</b>	70 mm
<b>Altezza nodi:</b>	Telaio + anta: 143-149 mm, centrale: 126 mm, soglia: 136-141 mm.
<b>Riempimenti:</b>	Tutti i tipi di riempimenti trasparenti e opachi da 5 fino a 53 mm.
<b>Tipi di apertura:</b>	

Schema A

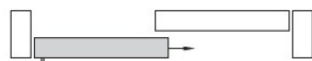

Schema C



Schema G



Schema K





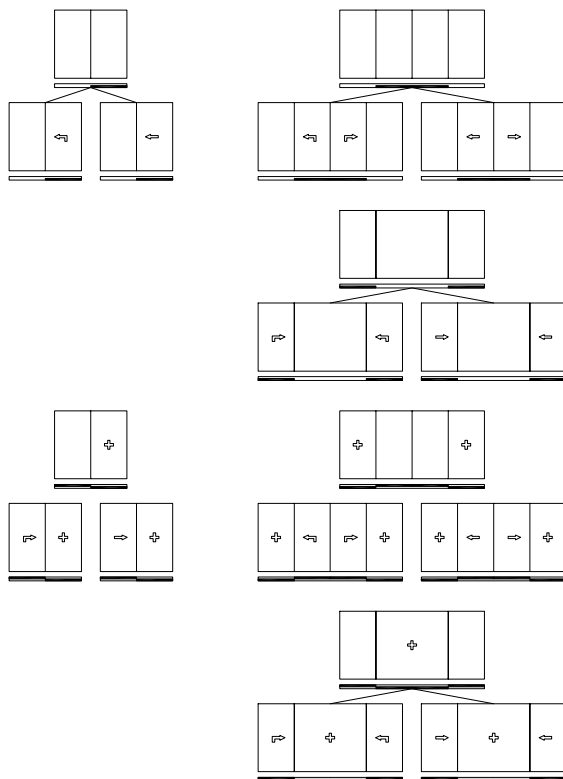

<b>Superfici:</b>	Verniciate a polvere o anodizzate.
<b>Drenaggio:</b>	Cappetta di drenaggio sulla parte bassa del telaio o drenaggio nascosto.
<b>Ulteriori possibilità:</b>	Resistenza all'effrazione RC2
<b>Opzioni:</b>	Sistema modulare per miglioramento termico secondo le necessità. Profilati di finitura. Profilati di rinforzo.
<b>Opzioni ferramenta:</b>	Scelta di diverse maniglie. Vedi capitolo ferramenta.

Varianti configurazioni:



Performance:

Test	Risultati		Norme	
	Isolamento termico	sagoma omega PA 6.6 GF25 di 35 mm		
		ATG 11/H772 - ATG 11/H730		
		I: $U_f = 2.8 - 3.4 \text{ W/m}^2\text{K}$		EN ISO 10077-1
		SI: $U_f = 2.6 - 3.2 \text{ W/m}^2\text{K}$		EN ISO 10077-1
		SHI: $U_f = 2.09 - 3.1 \text{ W/m}^2\text{K}$		EN ISO 10077-1
	Permeabilità aria	600 Pa	600 Pa	EN 12207
	Tenuta acqua	250 Pa	250 Pa	EN 12208
	Resistenza vento	1600 Pa	1600 Pa	EN12210



## OPZIONI TERMICHE

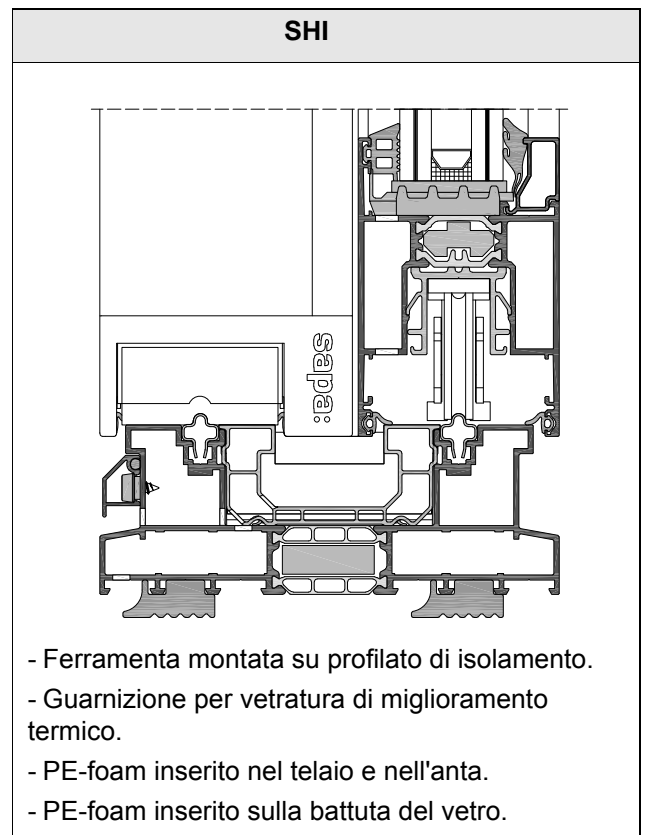
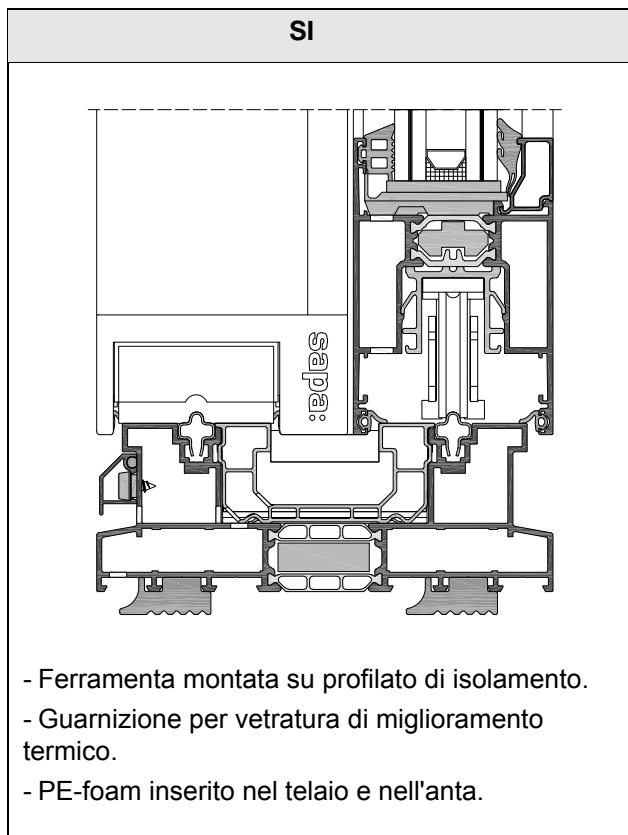
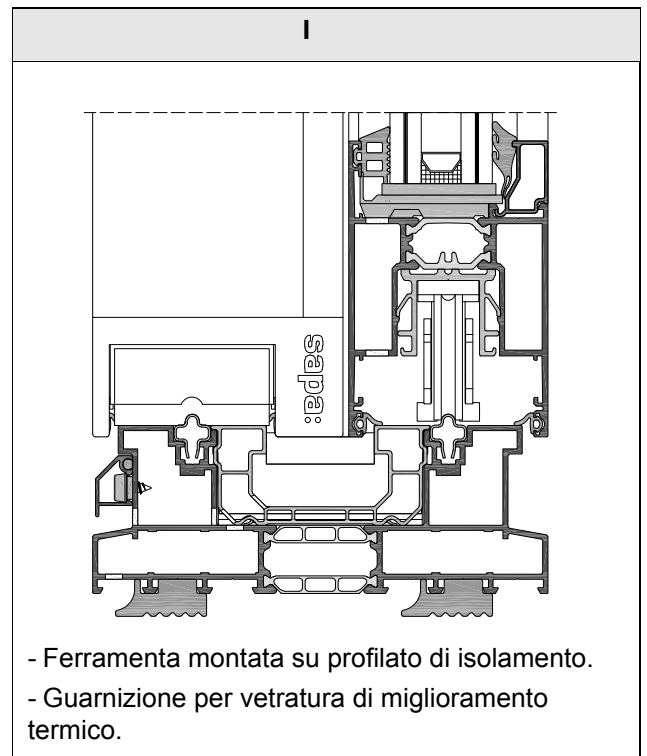





## DIRETTIVE GENERALI

1. All'esterno significa sempre sotto l'orizzontale e sinistra della sezione verticale

Interno

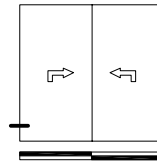
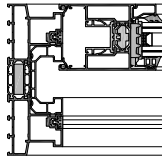

Esterno

Esterno

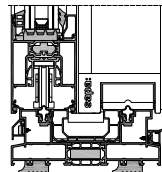

Interno

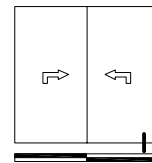

2. Le ante presenti nel catalogo rappresentano la parte di 'sinistra' secondo la norma EN 12519: 2004.

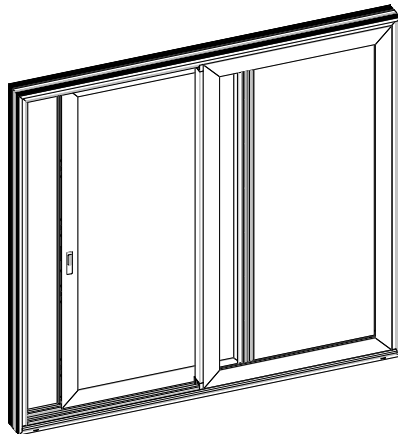

Sinistra in accordo alla EN 12519:2004.  
Default per catalogo.

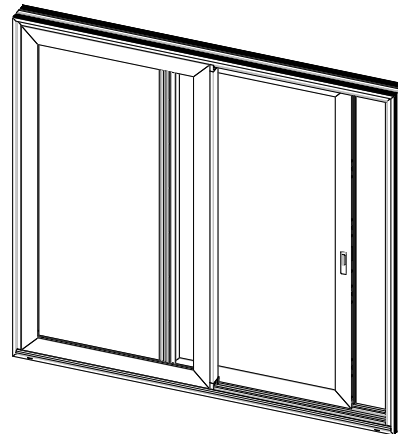

Destro in accordo alla EN 12519:2004.

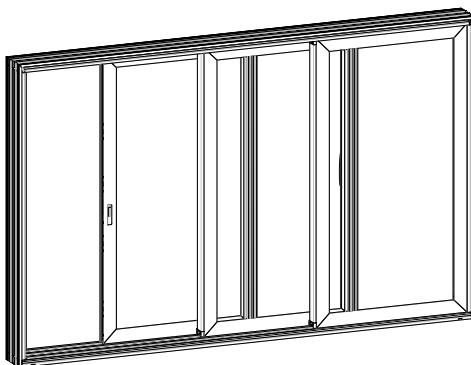

Sinistra in accordo alla EN 12519:2004.  
Default per catalogo.

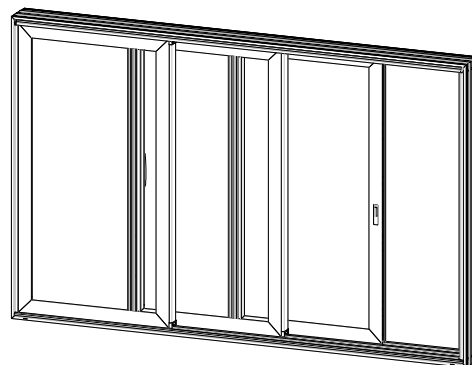

Destro in accordo alla EN 12519:2004.

3. Applicazioni

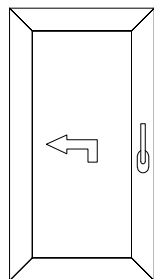

Anta alzante-scorrevole

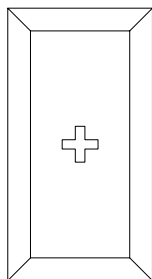

Anta fissa

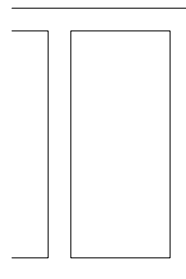







Vetro fisso





## RISULTATI DEI TEST

DOCUMENTO	PAESE	NUMERO
Approvazione tecnica	Belgio	ATG 12/2872



	TIPO DI FINESTRA	DIMENSIONI W x H (MM)	RISULTATI	TEST ISTITUTO NUMERO DOCUMENTO
<b>TEST FUNZIONALI</b>				
	2-binari alzante-scorrevole C9K020	2800 x 2400	4C, E1200A, 4 (EN12210, EN12208, EN12207)	WTCB NB 1136 CAR 10026
	2-binari 4 ante alzante- scorrevole C9K020	5150 x 2400	3C, 9A, 4 (EN12210, EN12208, EN12207)	WTCB NB 1136 CAR 10202
	1-binario alzante-scorrevole C9K010	2766 x 2388	4C, 8A, 4 (EN12210, EN12208, EN12207)	WTCB NB 1136 CAR 10178
	2-binari alzante-scorrevole finestra tagli 90 C9K120	2778 x 2400	4C, E1350A, 4 (EN12210, EN12208, EN12207)	WTCB NB 1136 CAR 11033
	3-binari alzante-scorrevole C9K030	4104 x 2400	4C, E900A, 4 (EN12210, EN12208, EN12207)	WTCB NB 1136 CAR 11032
	2-binari fisso-alzante-scorrevole- fisso	4200 x 2700	4C, 8A, 3 (EN12210, EN12208, EN12207)	LK24-1844-12-R12NK
	2-binari soglia ribassata fisso-alzante-scorrevole C9K100	2768 x 2382	4C, 6A, 4 (EN12210, EN12208, EN12207)	WTCB NB 1136 CAR 13368
	1-binario fisso-alzante-scorrevole C9K012	2800 x 2400	4C, 9A, 4 (EN12210, EN12208, EN12207)	WTCB NB 1136 CAR 14057
<b>TEST MECCANICI</b>				
	1-binario alzante-scorrevole finestra	2766 x 2388	Forza di funzionamento: 1 (EN 13115) Resistenza meccanica: 4 (EN 13115)	WTCB NB 1136 CAR 10178
	2-binari alzante-scorrevole finestra	2788x 2400	Forza di funzionamento: 1 (EN 13115) Resistenza meccanica: 4 (EN 13115)	WTCB NB 1136 CAR 11033
	2-binari doppia finestra alzante-scorrevole	2800x 2400	Forza di funzionamento: 1 (EN 13115) Resistenza meccanica: 4 (EN 13115)	WTCB NB 1136 CAR 10026
	2-binari fisso-alzante-scorrevole- fisso	4200 x 2700	Forza di funzionamento: 1 (EN 13115)	LK24-1844-12-R12NK

**RISULTATI DEI TEST**



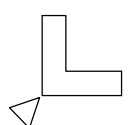
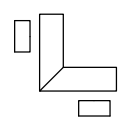
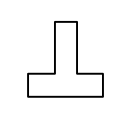
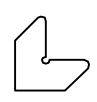
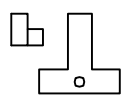
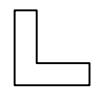
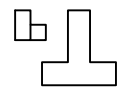

TEST ACUSTICI				
	C160 SHI - alzante-scorrevole	4100 x 2416	Rw(C;Ctr) = 37(-1;-2)dB con vetro 66.2/20/44.2 (Rw(C;Ctr)=43(-1;-5)dB)	CSTB NB 0679 AC11-26034308
	C160 SI - alzante-scorrevole	4100 x 2416	Rw(C;Ctr) = 36(-1;-2)dB con vetro 66.2/20/44.2 (Rw(C;Ctr)=43(-1;-5)dB)	CSTB NB 0679 AC11-26034308
	C160 Basic - alzante-scorrevole	4100 x 2416	Rw(C;Ctr) = 36(-1;-3)dB con vetro 66.2/20/44.2 (Rw(C;Ctr)=43(-1;-5)dB)	CSTB NB 0679 AC11-26034308
	C160 SHI - alzante-scorrevole doppia fisso alzante-scorrevole	3950 x 2400	Rw(C;Ctr) = 42(-1;-4)dB con vetro 66.2A/20/44.2A (Rw(C;Ctr)=50(-2;-5)dB)	WTCB NB 1136 AC5581 Bis
	C160 SHI - alzante-scorrevole Doppia 2-ante	3950 x 2400	Rw(C;Ctr) = 39(-1;-3)dB con vetro 66.2A/20/44.2A (Rw(C;Ctr)=50(-2;-5)dB)	WTCB NB 1136 AC5580 Bis
	C160 SHI - alzante-scorrevole Mono	3950 x 2400	Rw(C;Ctr) = 43(-1;-4)dB con vetro 66.2A/20/44.2A (Rw(C;Ctr)=50(-2;-5)dB)	WTCB NB 1136 AC5579 Bis
	C160 SHI - alzante-scorrevole Mono	3950 x 2400	Rw(C;Ctr) = 40(-1;-3)dB con vetro 10/12/44.2A (Rw(C;Ctr)=43(-2;-5)dB)	WTCB NB 1136 AC5578 Bis
TEST ANTIEFFRAZIONE				
	2 ante fisso-alzante-scorrevole due C9K020	2800 x 2400	Resistenza classe 2	SKG NB 0960 10.1036
	4 ante fisso-alzante-scorrevole-alzante-scorrevole-fisso due C9K020	5150 x 2400	Resistenza classe 2	SKG NB 0960 10.1110
			Dichiarazione di conformità Resistenza classe 2	SKG NB 0960 10.0925
TEST TERMICI				
			Vedi valori Uw di finestre nel capitolo K	
TEST ADDIZIONALI				
	Fissaggio viti			WTCB NB 1136 CAR 10145
	KOMO certificato		Resistenza classe 2	SKG NB 0960 SKG.0876.0313.04.NL

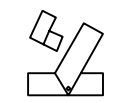
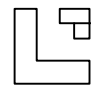
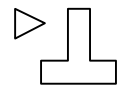
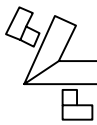
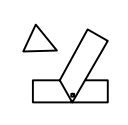
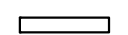



**Profilati sistema**

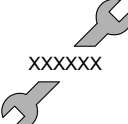

<b>A</b>	Canali squadrette allineamento		Squadrette meccaniche
<b>B</b>	Tubolarità esterna per squadrette		Squadrette meccaniche fissaggio con viti
<b>C</b>	Tubolarità interna per squadrette		Supporti per alette
	Squadrette allineamento		Cavallotto con eccentrico tipo 1
	Squadrette a cianfrinare		Cavallotto con eccentrico tipo 2
	Squadrette a spinare		Cavallotto angolo variabile con eccentrico
	Squadrette con eccentrico		Cavallotto a spinare
	Squadretta angolo variabile con eccentrico		Cavallotto angolo variabile a spinare
			Piatto blindatura

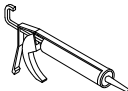

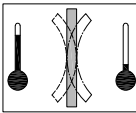

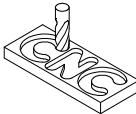
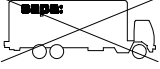
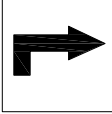









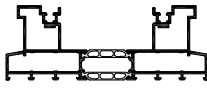

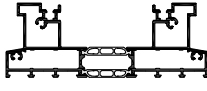

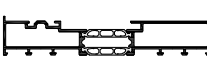
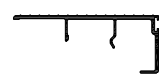
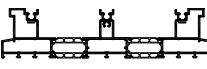

LISTA DEI SIMBOLI

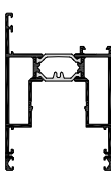
	Numero pagina
	Posizione del profilato
	Lunghezza del profilato (m)
<b>Ixx</b> <b>Iyy</b>	Momento di inerzia secondo assi XX/YY (cm <sup>4</sup> )
	Superficie anodizzata o verniciata (dm <sup>2</sup> /m)
	Superficie di pulizia (dm <sup>2</sup> /m)
 xxxxxx	Codice attrezzo
	Collegamento a vite
 X.X.X	Vedi disegno
 xxxxxx	Numero confezione
 xxxxxx	Pezzi nella confezione

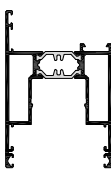



	Silicone, colla
	Rompere o tagliare
	Unità di misura confezione
	Effetto bi-metallo
	Resistenza all'effrazione, classe Europea 2
	CNC centro di lavoro
	Non fornito da Domal
	Soluzione alzante-scorrevole

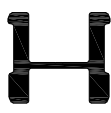
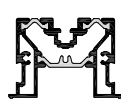
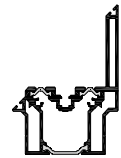









## LISTA PROFILATI









TELAIO			PROFILATI CARTELLINE		
	CODICE			CODICE	
	<b>C9K020</b>	B.2.1		<b>C9A001</b>	B.5.1
	<b>C9K120</b>	B.2.2		<b>C9A002</b>	B.5.1
	<b>C9K121</b>	B.2.2		<b>C9A020</b>	B.5.2
	<b>C9K030</b>	B.2.3			
ANTA			PROFILATI GOCCIOLATOI		
	CODICE			CODICE	
	<b>C9V001</b>	B.3.1		<b>52A28</b>	B.6.1
	<b>C9V051</b>	B.3.2		<b>C9A004</b>	B.6.1
				<b>C9A003</b>	B.6.2
RINFORZO			PROFILATI GUIDA		
	CODICE			CODICE	
	<b>C9C001</b>	B.4.1		<b>C9C002</b>	B.7.1
				<b>C9C003</b>	B.7.2



**LISTA PROFILATI**

PROFILATI COMPLEMENTARI		
	CODICE	
	<b>CO2206</b>	B.8.1
	<b>CO2181</b>	B.8.1
	<b>C9A100</b>	B.8.2

FERMAVETRO - STANDARD - 22 MM		
	CODICE	
	<b>GC0303</b>	D.2.1
	<b>GC0307</b>	D.2.1





FERMAVETRO - TUBOLARI - 22 MM		
	CODICE	
	<b>GC2310</b>	D.2.1
	<b>GC2312</b>	D.2.1

FERMAVETRO - TUBOLARI - 22 MM		
	CODICE	
	<b>GC2315</b>	D.2.1
	<b>GC2317</b>	D.2.1
	<b>GC2320</b>	D.2.1
	<b>GC2322</b>	D.2.1
	<b>GC2325</b>	D.2.1
	<b>GC2327</b>	D.2.1
	<b>GC2330</b>	D.2.1

FINESTRE - PROFILATI DI FINITURA		
	CODICE	
	<b>Z9A016</b>	C.1.1









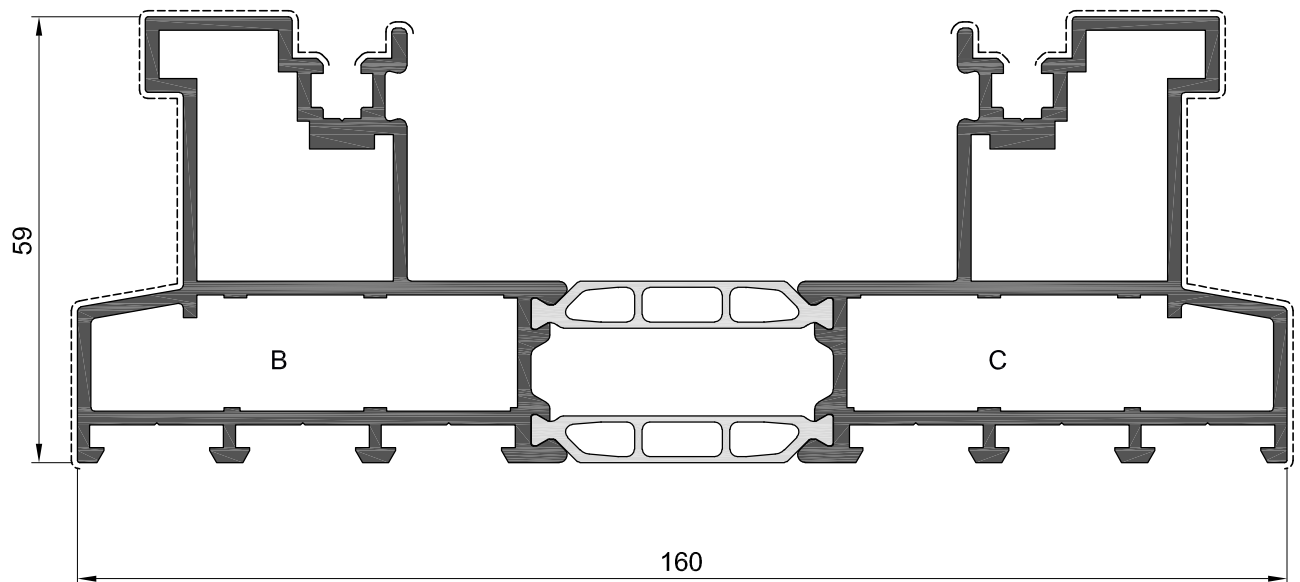

## LISTA PROFILATI

FINESTRE - PROFILATI DI FINITURA		
	CODICE	
	<b>Z9C005</b>	C.1.1
	<b>Z9C030</b>	C.1.1









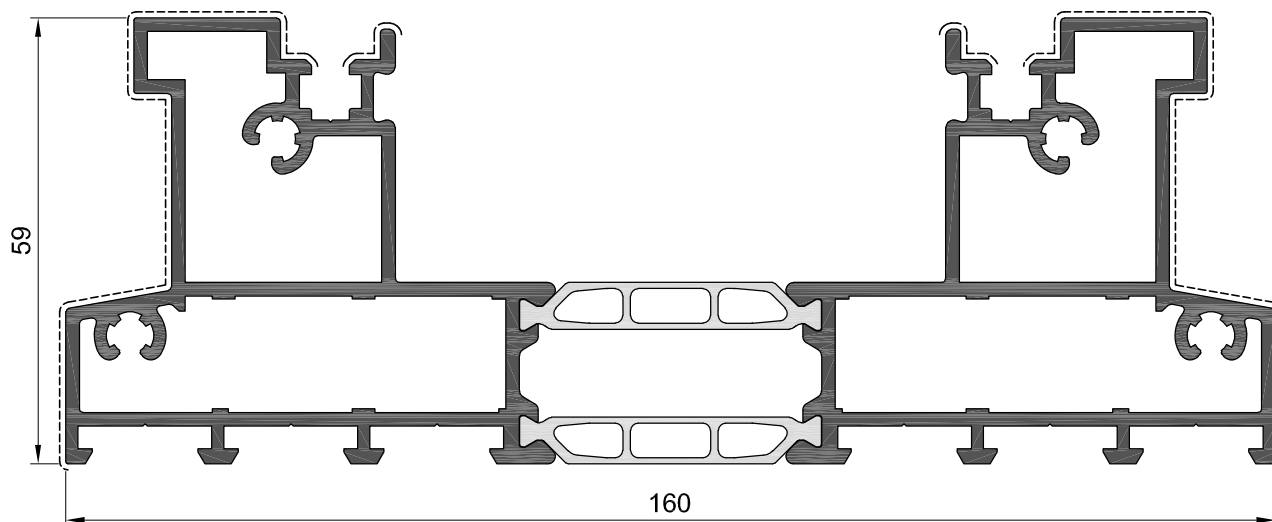







 dm <sup>2</sup> /m	64.49	<b>B</b>		HV0G03	<b>C</b>		HV2W11	-	-		J.2.1	
 dm <sup>2</sup> /m	23.01	<b>B</b>		HV2W11	-	-	-	-	-		H.1.15	
$\gamma_{\frac{1}{2}} \gamma_{\frac{1}{2}}$ I <sub>yy</sub> cm <sup>4</sup>	41.89	<b>C</b>		HV0G03	-	-	-	-	-	 m	7.0	
mm	<b>800</b>	<b>1000</b>	<b>1200</b>	<b>1400</b>	<b>1600</b>	<b>1800</b>	<b>2000</b>	<b>2200</b>	<b>2400</b>	<b>2600</b>	<b>2800</b>	<b>3000</b>
$\gamma_{\frac{1}{2}} \gamma_{\frac{1}{2}}$ I <sub>xx</sub> cm <sup>4</sup>	75.82	92.55	110.22	127.97	145.17	161.41	176.47	190.24	202.72	213.95	224.04	233.06







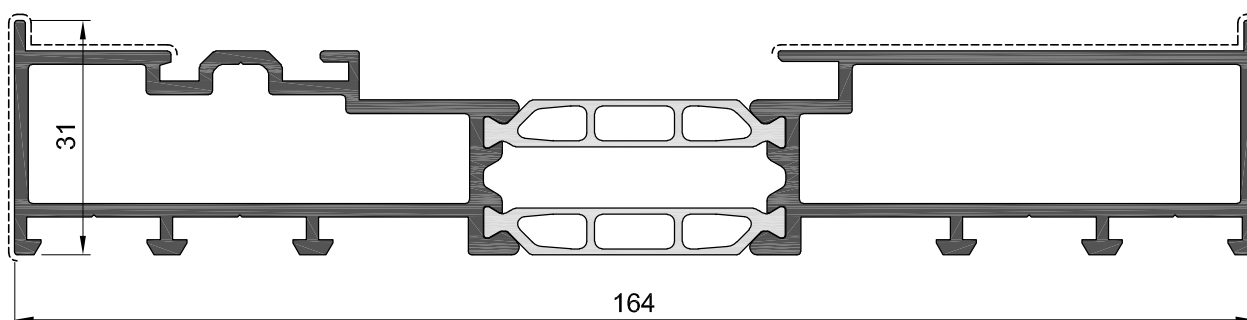

**C9K120**



 dm <sup>2</sup> /m	64.49	<b>B</b>		HV0G03	<b>C</b>		HV2W11	-	-		J.3.6	
 dm <sup>2</sup> /m	23.01	<b>B</b>		HV2W11	-	-	-	-	-		H.1.6	
 lyy cm <sup>4</sup>	43.08	<b>C</b>		HV0G03	-	-	-	-	-	 m	7.0	
 mm	<b>800</b>	<b>1000</b>	<b>1200</b>	<b>1400</b>	<b>1600</b>	<b>1800</b>	<b>2000</b>	<b>2200</b>	<b>2400</b>	<b>2600</b>	<b>2800</b>	<b>3000</b>
 lxx cm <sup>4</sup>	61.85	72.00	83.52	96.00	109.09	122.46	135.83	148.97	161.73	173.97	185.62	196.64

**C9K121**



 dm <sup>2</sup> /m	49.79	-	-	-	-	-	-	-	-	-		J.3.4
 dm <sup>2</sup> /m	15.40	-	-	-	-	-	-	-	-	-		-
 lyy cm <sup>4</sup>	6.97	-	-	-	-	-	-	-	-	-	 m	7.0
 mm	<b>800</b>	<b>1000</b>	<b>1200</b>	<b>1400</b>	<b>1600</b>	<b>1800</b>	<b>2000</b>	<b>2200</b>	<b>2400</b>	<b>2600</b>	<b>2800</b>	<b>3000</b>
 lxx cm <sup>4</sup>	55.89	64.77	74.45	84.49	94.55	104.35	113.72	122.54	130.74	138.30	145.23	151.56

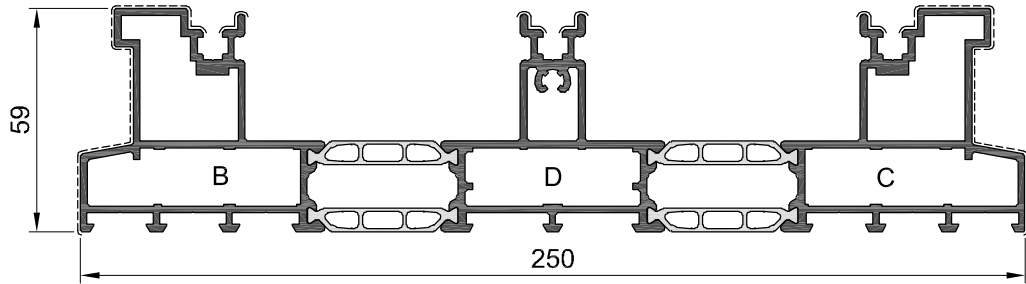







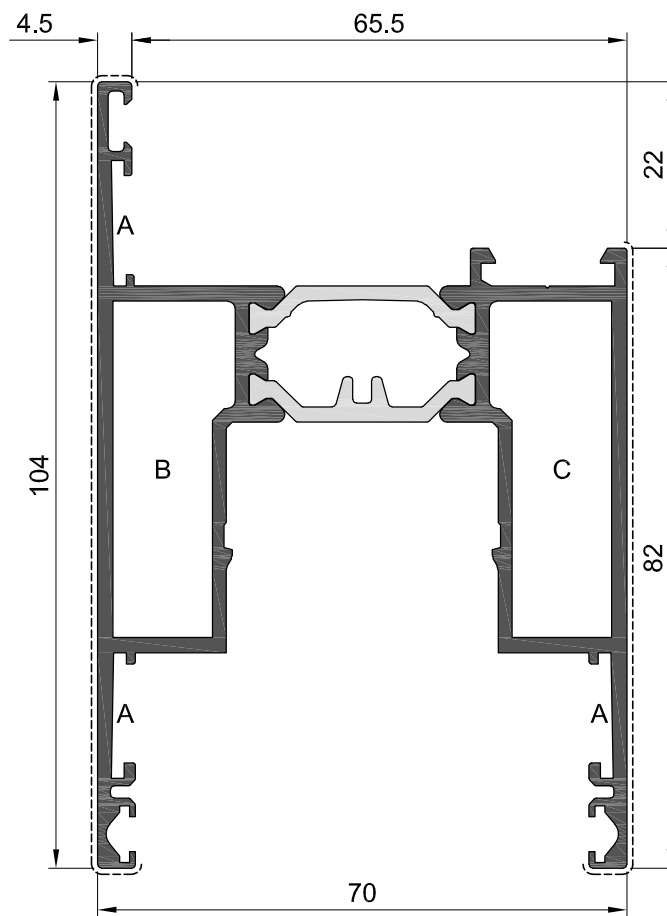



**C9K030**

	dm <sup>2</sup> /m	56.13	<b>C</b>		HV0G03				-	-		J.4.4	
	dm <sup>2</sup> /m	13.64	<b>B</b>		HV0G03				-	-		H.1.9	
	lyy cm <sup>4</sup>	41.76	<b>D</b>		HV0G03	-	-	-	-	-		m 7.0	
	mm	<b>800</b>	<b>1000</b>	<b>1200</b>	<b>1400</b>	<b>1600</b>	<b>1800</b>	<b>2000</b>	<b>2200</b>	<b>2400</b>	<b>2600</b>	<b>2800</b>	<b>3000</b>
	lxx cm <sup>4</sup>	75.80	92.65	110.44	238.33	145.66	162.03	177.21	191.10	203.68	215.02	225.19	234.30





**C9V001**

 dm <sup>2</sup> /m	55.07	<b>A</b> 	HV4K01		<b>C</b> 	HV2W10		-	-		J.6.1	
 dm <sup>2</sup> /m	20.09	<b>B</b> 	HV2W10		<b>C</b> 	HV3H26		-	-		-	
$\gamma_{\frac{1}{2}}$ lyy cm <sup>4</sup>	48.12	<b>B</b> 	HV3H26		-	-		-	-	 m	7.0	
mm	<b>800</b>	<b>1000</b>	<b>1200</b>	<b>1400</b>	<b>1600</b>	<b>1800</b>	<b>2000</b>	<b>2200</b>	<b>2400</b>	<b>2600</b>	<b>2800</b>	<b>3000</b>
$\gamma_{\frac{1}{2}}$ lxx cm <sup>4</sup>	15.23	19.51	23.77	27.79	31.48	34.78	37.7	40.25	42.48	44.42	46.1	47.57





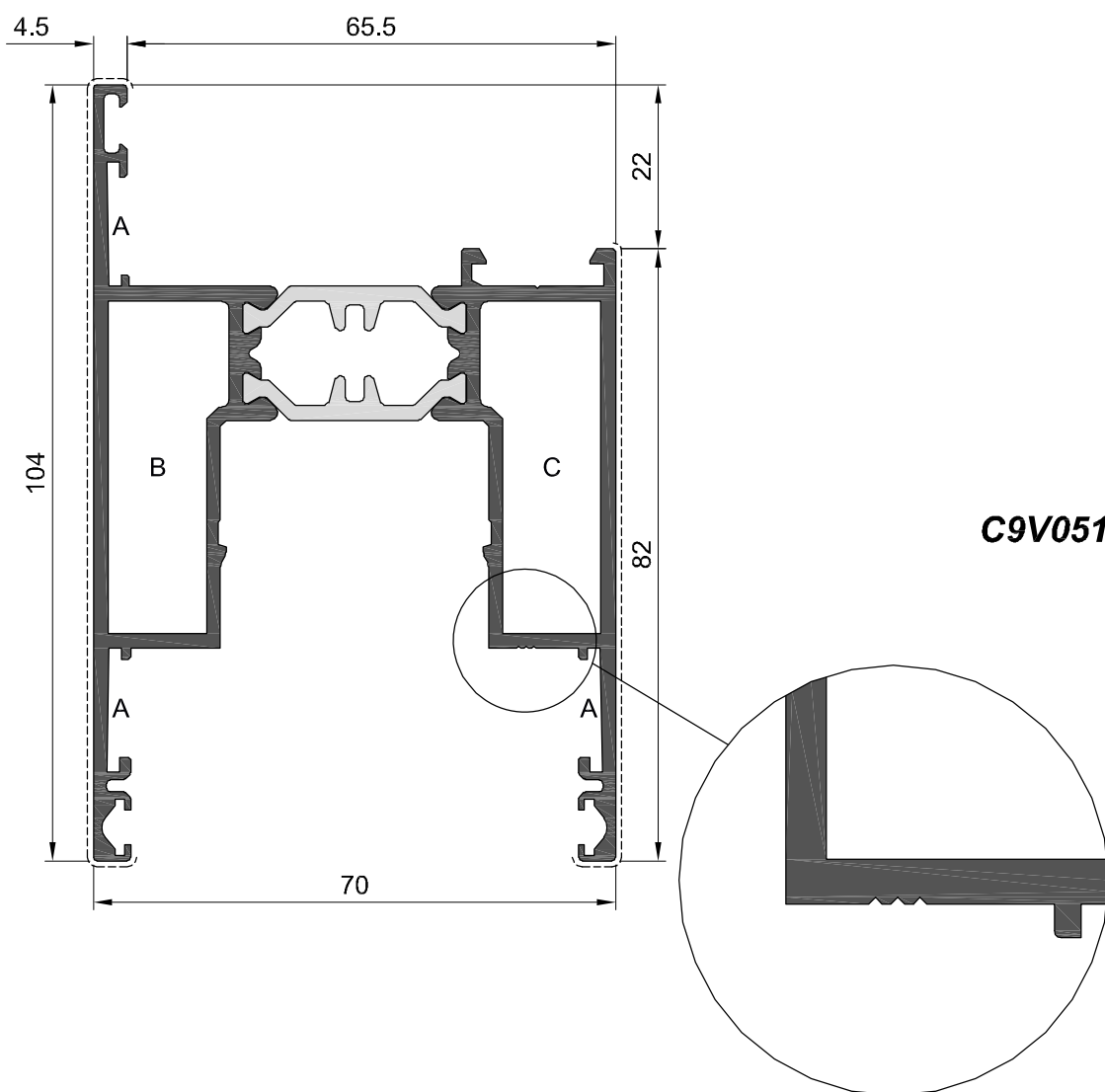



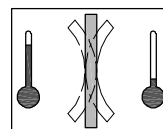





Bi-metal profile



**C9V051**







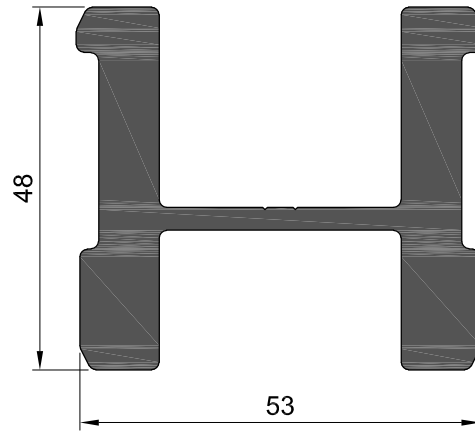



 dm <sup>2</sup> /m	55.07	<b>A</b> 	HV4K01	<b>C</b> 	HV2W10	-	-		J.6.1			
 dm <sup>2</sup> /m	20.09	<b>B</b> 	HV2W10	<b>C</b> 	HV3H26	-	-		-			
 lyy cm <sup>4</sup>	4.97	<b>B</b> 	HV3H26	-	-	-	-	 m	7.0			
mm	<b>800</b>	<b>1000</b>	<b>1200</b>	<b>1400</b>	<b>1600</b>	<b>1800</b>	<b>2000</b>	<b>2200</b>	<b>2400</b>	<b>2600</b>	<b>2800</b>	<b>3000</b>
 lxx cm <sup>4</sup>	4.97	4.97	4.97	4.97	4.97	4.97	4.97	4.97	4.97	4.97	4.97	4.97











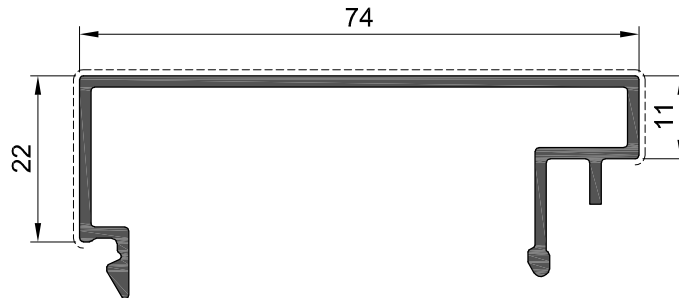

**C9C001**

 dm <sup>2</sup> /m	29.25	-	-	-	-	-	-	-	-	-		J.10.7
 dm <sup>2</sup> /m	0.00	-	-	-	-	-	-	-	-	-		H.1.21
 I <sub>yy</sub> cm <sup>4</sup>	18.10	-	-	-	-	-	-	-	-	-	 m	7.0
 mm	<b>800</b>	<b>1000</b>	<b>1200</b>	<b>1400</b>	<b>1600</b>	<b>1800</b>	<b>2000</b>	<b>2200</b>	<b>2400</b>	<b>2600</b>	<b>2800</b>	<b>3000</b>
 I <sub>xx</sub> cm <sup>4</sup>	-	38.75	-	-	-	-	-	-	-	-	-	-









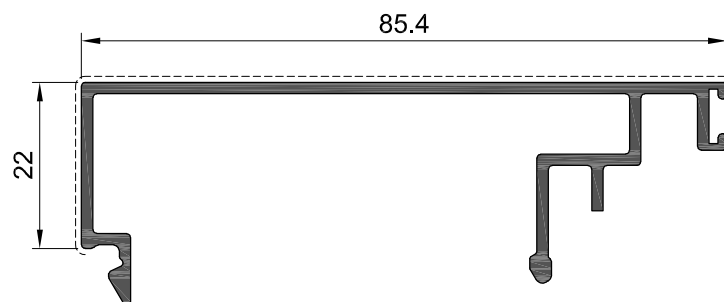



**C9A001**

 dm <sup>2</sup> /m	30.22	-	-	-	-	-	-	-	-	-		J.10.7
 dm <sup>2</sup> /m	10.71	-	-	-	-	-	-	-	-	-		-
 lyy cm <sup>4</sup>	1.78	-	-	-	-	-	-	-	-	-	 m	6.0
 mm	<b>800</b>	<b>1000</b>	<b>1200</b>	<b>1400</b>	<b>1600</b>	<b>1800</b>	<b>2000</b>	<b>2200</b>	<b>2400</b>	<b>2600</b>	<b>2800</b>	<b>3000</b>
 lxx cm <sup>4</sup>	-	17.28	-	-	-	-	-	-	-	-	-	-







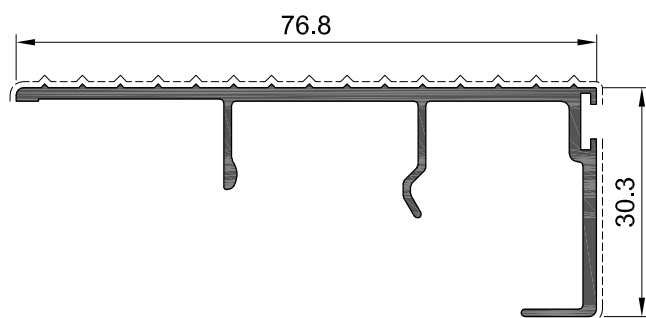



**C9A002**

 dm <sup>2</sup> /m	34.99	-	-	-	-	-	-	-	-	-		J.10.7
 dm <sup>2</sup> /m	11.01	-	-	-	-	-	-	-	-	-		-
 lyy cm <sup>4</sup>	1.88	-	-	-	-	-	-	-	-	-	 m	6.0
 mm	<b>800</b>	<b>1000</b>	<b>1200</b>	<b>1400</b>	<b>1600</b>	<b>1800</b>	<b>2000</b>	<b>2200</b>	<b>2400</b>	<b>2600</b>	<b>2800</b>	<b>3000</b>
 lxx cm <sup>4</sup>	-	22.92	-	-	-	-	-	-	-	-	-	-







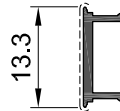



**C9A020**

 dm <sup>2</sup> /m	29.81	-	-	-	-	-	-	-	-	-		J.1.93
 dm <sup>2</sup> /m	11.07	-	-	-	-	-	-	-	-	-		H.1.89
 l <sub>yy</sub> cm <sup>4</sup>	1.74	-	-	-	-	-	-	-	-	-	 m	7
 mm	<b>800</b>	<b>1000</b>	<b>1200</b>	<b>1400</b>	<b>1600</b>	<b>1800</b>	<b>2000</b>	<b>2200</b>	<b>2400</b>	<b>2600</b>	<b>2800</b>	<b>3000</b>
 l <sub>xx</sub> cm <sup>4</sup>	-	12.32	-	-	-	-	-	-	-	-	-	-







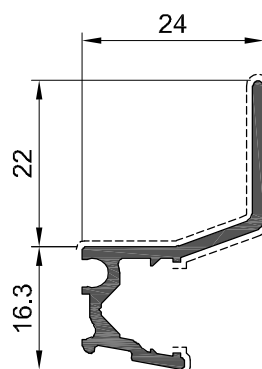



**52A28**

 dm <sup>2</sup> /m	4.52	-	-	-	-	-	-	-	-	-		-
 dm <sup>2</sup> /m	1.38	-	-	-	-	-	-	-	-	-		H.1.16
 l <sub>yy</sub> cm <sup>4</sup>	0.04	-	-	-	-	-	-	-	-	-	 m	7.0
 mm	<b>800</b>	<b>1000</b>	<b>1200</b>	<b>1400</b>	<b>1600</b>	<b>1800</b>	<b>2000</b>	<b>2200</b>	<b>2400</b>	<b>2600</b>	<b>2800</b>	<b>3000</b>
 l <sub>xx</sub> cm <sup>4</sup>	-	0.00	-	-	-	-	-	-	-	-	-	-







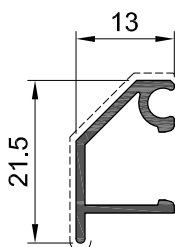



**C9A004**

 dm <sup>2</sup> /m	14.64	-	-	-	-	-	-	-	-	-		J.5.27
 dm <sup>2</sup> /m	7.87	-	-	-	-	-	-	-	-	-		H.1.16
 l <sub>yy</sub> cm <sup>4</sup>	1.08	-	-	-	-	-	-	-	-	-	 m	7.0
 mm	<b>800</b>	<b>1000</b>	<b>1200</b>	<b>1400</b>	<b>1600</b>	<b>1800</b>	<b>2000</b>	<b>2200</b>	<b>2400</b>	<b>2600</b>	<b>2800</b>	<b>3000</b>
 l <sub>xx</sub> cm <sup>4</sup>	-	0.80	-	-	-	-	-	-	-	-	-	-







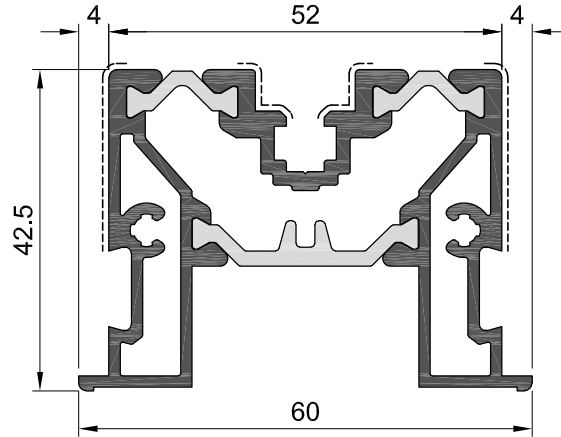



**C9A003**

 dm <sup>2</sup> /m	9.83	-	-	-	-	-	-	-	-	-		J.5.26
 dm <sup>2</sup> /m	4.58	-	-	-	-	-	-	-	-	-		H.1.9
 lyy cm <sup>4</sup>	0.25	-	-	-	-	-	-	-	-	-	 m	7.0
 mm	<b>800</b>	<b>1000</b>	<b>1200</b>	<b>1400</b>	<b>1600</b>	<b>1800</b>	<b>2000</b>	<b>2200</b>	<b>2400</b>	<b>2600</b>	<b>2800</b>	<b>3000</b>
 lxx cm <sup>4</sup>	-	0.11	-	-	-	-	-	-	-	-	-	-







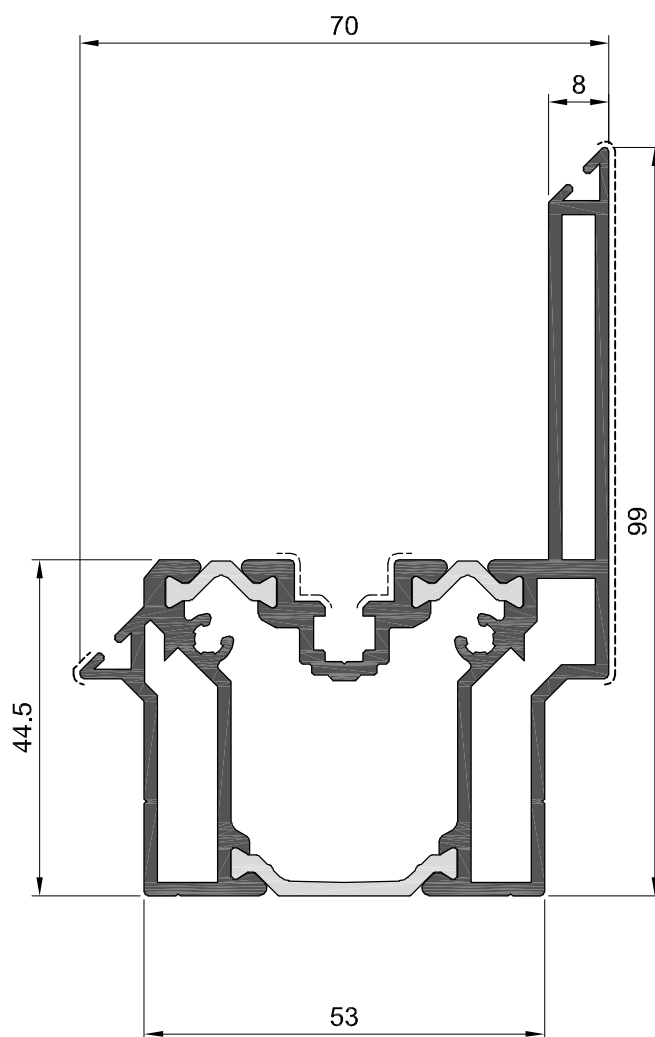

C9C002

 dm <sup>2</sup> /m	15.02	-	-	-	-	-	-	-	-	-		J.10.23
 dm <sup>2</sup> /m	6.26	-	-	-	-	-	-	-	-	-		H.1.5
 I <sub>yy</sub> cm <sup>4</sup>	6.07	-	-	-	-	-	-	-	-	-	 m	7.0
 mm	<b>800</b>	<b>1000</b>	<b>1200</b>	<b>1400</b>	<b>1600</b>	<b>1800</b>	<b>2000</b>	<b>2200</b>	<b>2400</b>	<b>2600</b>	<b>2800</b>	<b>3000</b>
 I <sub>xx</sub> cm <sup>4</sup>	3.75	5.03	6.23	7.54	8.66	9.68	10.58	11.37	12.06	12.66	13.19	13.65



**C9C003**

 dm <sup>2</sup> /m	58.61	-	-	-	-	-	-	-	-	-		-
 dm <sup>2</sup> /m	11.11	-	-	-	-	-	-	-	-	-		-
 lyy cm <sup>4</sup>	6.07	-	-	-	-	-	-	-	-	-	 m	7.0
mm	<b>800</b>	<b>1000</b>	<b>1200</b>	<b>1400</b>	<b>1600</b>	<b>1800</b>	<b>2000</b>	<b>2200</b>	<b>2400</b>	<b>2600</b>	<b>2800</b>	<b>3000</b>
 lxx cm <sup>4</sup>	6.91	8.91	11.05	13.21	15.31	17.32	19.19	20.91	22.47	23.89	25.17	26.32



# PROFILATI SISTEMA domal

## PROFILATI COMPLEMENTARI

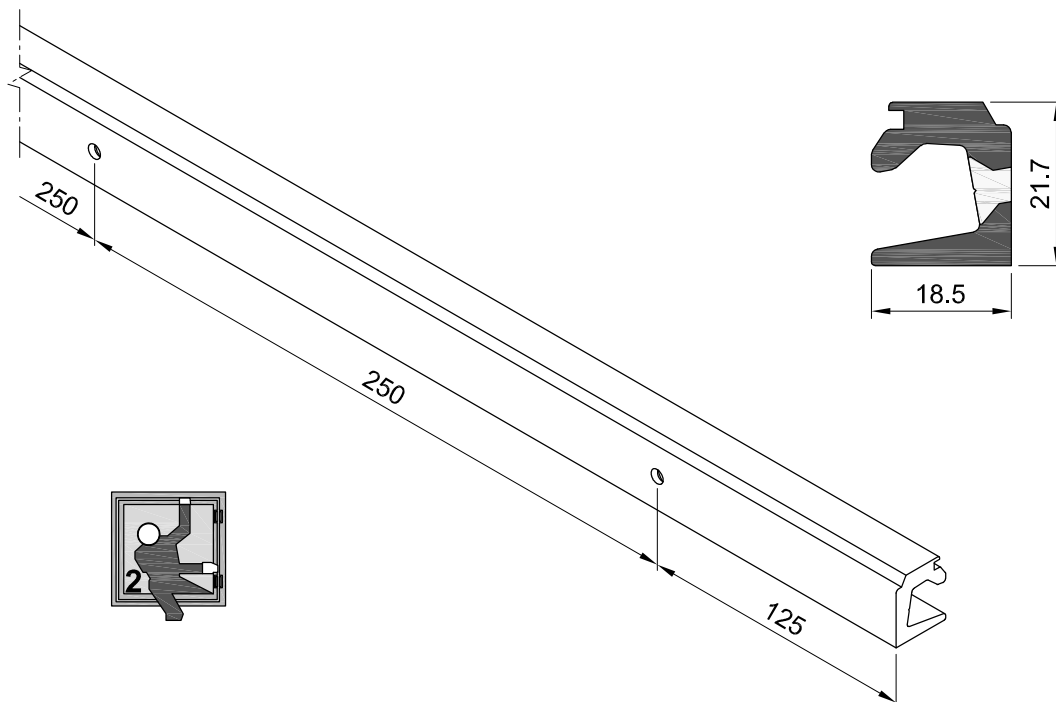

**CO2206**

	dm <sup>2</sup> /m	10.92	-	-	-	-	-	-	-	-		J.8.3	
	dm <sup>2</sup> /m	6.49	-	-	-	-	-	-	-	-		-	
	lyy cm <sup>4</sup>	0.60	-	-	-	-	-	-	-	-		m 7.0	
	mm	<b>800</b>	<b>1000</b>	<b>1200</b>	<b>1400</b>	<b>1600</b>	<b>1800</b>	<b>2000</b>	<b>2200</b>	<b>2400</b>	<b>2600</b>	<b>2800</b>	<b>3000</b>
	lxx cm <sup>4</sup>	-	1.12	-	-	-	-	-	-	-	-	-	-

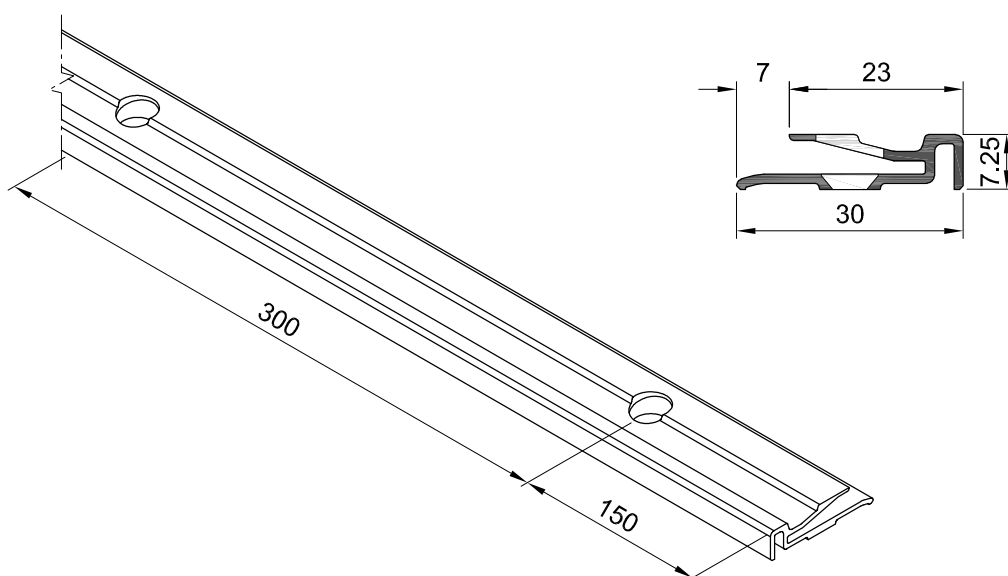





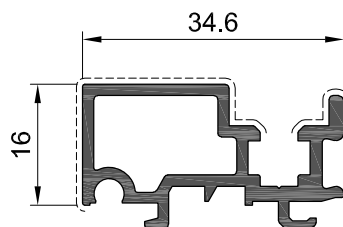



**CO2181**

	dm <sup>2</sup> /m	11.95	-	-	-	-	-	-	-	-		-	
	dm <sup>2</sup> /m	3.86	-	-	-	-	-	-	-	-		-	
	lyy cm <sup>4</sup>	0.04	-	-	-	-	-	-	-	-		m 3.0	
	mm	<b>800</b>	<b>1000</b>	<b>1200</b>	<b>1400</b>	<b>1600</b>	<b>1800</b>	<b>2000</b>	<b>2200</b>	<b>2400</b>	<b>2600</b>	<b>2800</b>	<b>3000</b>
	lxx cm <sup>4</sup>	-	0.50	-	-	-	-	-	-	-	-	-	-



**C9A100**

 dm <sup>2</sup> /m	17.11	-	-	-	-	-	-	-	-	-		J.3.30
 dm <sup>2</sup> /m	5.59	-	-	-	-	-	-	-	-	-		-
 lyy cm <sup>4</sup>	0.59	-	-	-	-	-	-	-	-	-	 m	7.0
 mm	<b>800</b>	<b>1000</b>	<b>1200</b>	<b>1400</b>	<b>1600</b>	<b>1800</b>	<b>2000</b>	<b>2200</b>	<b>2400</b>	<b>2600</b>	<b>2800</b>	<b>3000</b>
 lxx cm <sup>4</sup>	-	2.25	-	-	-	-	-	-	-	-	-	-



**MOMENTO DI INERZIA**

	I <sub>xx</sub> (CM <sup>4</sup> )											
	LUNGHEZZA [MM]											
	800	1000	1200	1400	1600	1800	2000	2200	2400	2600	2800	3000
<b>C9C002</b>	3.75	5.03	6.23	7.54	8.66	9.68	10.58	11.37	12.06	12.66	13.19	13.65
<b>C9C003</b>	6.91	8.91	11.05	13.21	15.31	17.32	19.19	20.91	22.47	23.89	25.17	26.32
<b>C9K020</b>	75.82	92.55	110.22	127.97	145.17	161.41	176.47	190.24	202.72	213.95	224.04	233.06
<b>C9K030</b>	75.80	92.65	110.44	238.33	145.66	162.03	177.21	191.10	203.68	215.02	225.19	234.30
<b>C9K120</b>	61.85	72.00	83.52	96.00	109.09	122.46	135.83	148.97	161.73	173.97	185.62	196.64
<b>C9K121</b>	55.89	64.77	74.45	84.49	94.55	104.35	113.72	122.54	130.74	138.30	145.23	151.56
<b>C9V001</b>	15.23	19.51	23.77	27.79	31.48	34.78	37.7	40.25	42.48	44.42	46.1	47.57
<b>C9V051</b>	4.97	4.97	4.97	4.97	4.97	4.97	4.97	4.97	4.97	4.97	4.97	4.97





**Profilati vari**



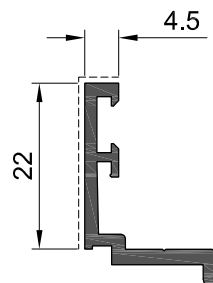
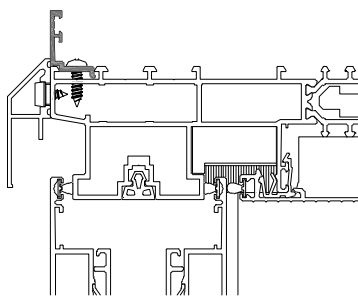

**Z9A016**

(dm <sup>2</sup> /m)	10.9
(dm <sup>2</sup> /m)	2.65
$\gamma \frac{x}{2} \gamma$ Ixx (cm <sup>4</sup> )	0.27
$\gamma \frac{x}{2} \gamma$ Iyy (cm <sup>4</sup> )	0.59
-	m 6.0

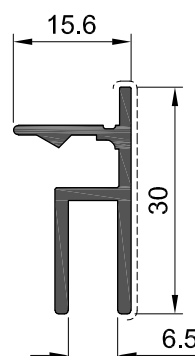
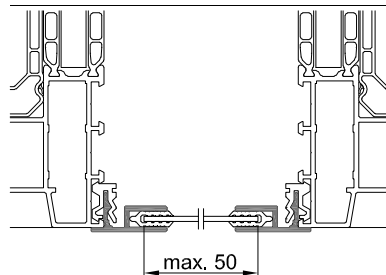

**Z9C005**

(dm <sup>2</sup> /m)	13.86
(dm <sup>2</sup> /m)	3.35
$\gamma \frac{x}{2} \gamma$ Ixx (cm <sup>4</sup> )	0.21
$\gamma \frac{x}{2} \gamma$ Iyy (cm <sup>4</sup> )	0.78
-	m 6.0

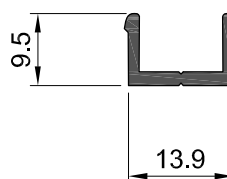
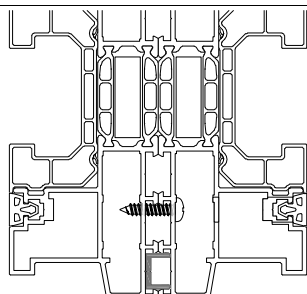

**Z9C030**

(dm <sup>2</sup> /m)	6.24
(dm <sup>2</sup> /m)	0
$\gamma \frac{x}{2} \gamma$ Ixx (cm <sup>4</sup> )	0.13
$\gamma \frac{x}{2} \gamma$ Iyy (cm <sup>4</sup> )	0.04
-	m 6.0







**Vetratura**



#### SCELTA FERMAVETRI E GUARNIZIONI

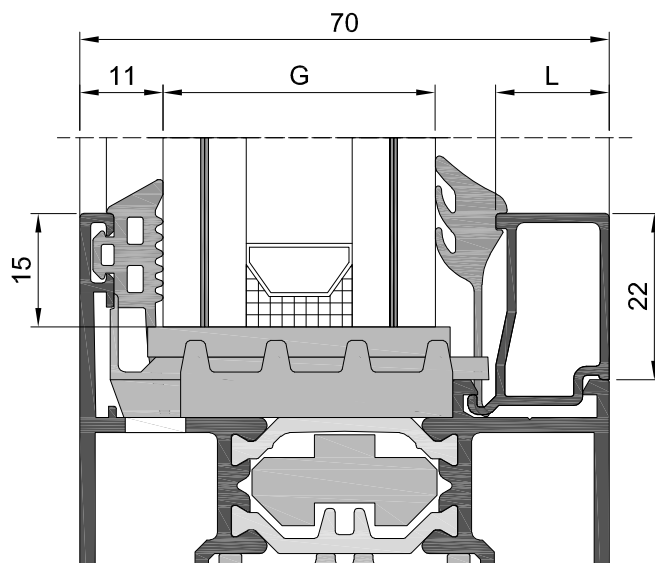

- Lo spessore del vetro dipende da:
  - \* pressione dinamica base del vento
  - \* caratteristiche della vetratura, sue dimensioni e applicazioni
  - \* applicazione
  - \* posizione
- Il vetro e la sua installazione devono essere conformi alle direttive vigenti e le specifiche del produttore autorizzato (vetro isolante deve avere una licenza tecnica)
- Prima della installazione del vetro verificarne lo spessore, le dimensioni e la geometria dei volumi con le direttive e specifiche.

## TABELLA VETRATURA

### VETRATURA CON RU0004





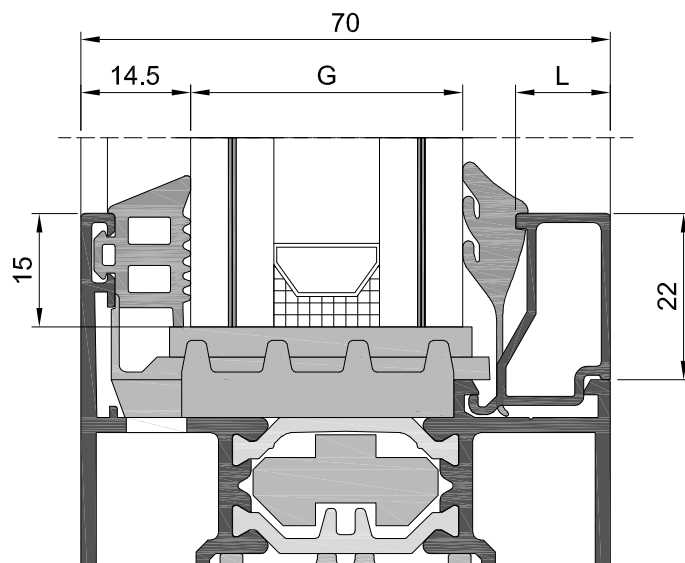

G (MM)				L (MM)	 TUBOLARE
	39R506	39R507	39R508		
	4 - 6 MM	6 - 7.5 MM	7.5 - 9 MM		
23		•		30	GC2330
24			•	27.5	GC2327
25		•		27.5	GC2327
26	•			27.5	GC2327
27		•		25	GC2325
28		•		25	GC2325
29			•	22.5	GC2322
30		•		22.5	GC2322
31	•			22.5	GC2322
32		•		20	GC2320
33		•		20	GC2320
34			•	17.5	GC2317
35		•		17.5	GC2317
36	•			17.5	GC2317
37		•		15	GC2315
38		•		15	GC2315
39			•	12.5	GC2312
40		•		12.5	GC2312
41	•			12.5	GC2312
42		•		10	GC2310
43		•		10	GC2310

G (MM)				L (MM)	 STANDARD
	39R506	39R507	39R508		
	4 - 6 MM	6 - 7.5 MM	7.5 - 9 MM		
44			•	7.5	GC0307
45		•		7.5	GC0307
46	•			7.5	GC0307
49		•		3	GC0303
50		•		3	GC0303

VETRATURA CON RU0002



G (MM)				L (MM)	
	39R506	39R507	39R508		
	4 - 6 MM	6 - 7.5 MM	7.5 - 9 MM		CLASSIC
23			•	25	GC2325
24		•		25	GC2325
25	•			25	GC2325
26		•		22.5	GC2322
27		•		22.5	GC2322
28			•	20	GC2320
29		•		20	GC2320
30	•			20	GC2320
31		•		17.5	GC2317
32		•		17.5	GC2317
33			•	15	GC2315
34		•		15	GC2315
35	•			15	GC2315
36		•		12.5	GC2312
37		•		12.5	GC2312
38			•	10	GC2310
39		•		10	GC2310
40	•			10	GC2310

G (MM)				L (MM)	
	39R506	39R507	39R508		
	4 - 6 MM	6 - 7.5 MM	7.5 - 9 MM		
41		•		7.5	GC0307
42		•		7.5	GC0307
45			•	3	GC0303
46		•		3	GC0303
47	•			3	GC0303

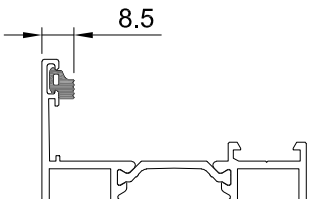
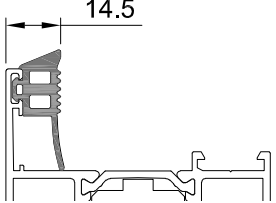
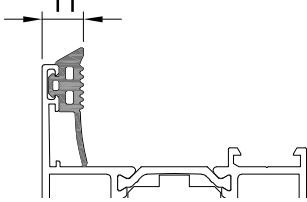

TUBOLARE						
L [mm]	CLASSICO	[dm <sup>2</sup> / m]	[dm <sup>2</sup> / m]			
3	<b>GC0303</b>	9.11	2.51			
7.5	<b>GC0307</b>	11.40	2.96			
10	<b>GC2310</b>	8.99	3.21			
12.5	<b>GC2312</b>	9.13	3.47			
15	<b>GC2315</b>	9.29	3.72			
17.5	<b>GC2317</b>	9.53	3.97			
20	<b>GC2320</b>	9.86	4.22			
22.5	<b>GC2322</b>	10.26	4.46			
25	<b>GC2325</b>	10.68	4.72			
27.5	<b>GC2327</b>	11.16	4.96			
30	<b>GC2330</b>	11.53	5.21			

	<p><b>210-003</b></p>
	<p><b>RU0002</b></p>
	<p><b>RU0004</b></p>

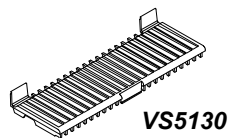



**Accessori**







**SQUADRETTE - SQUADRETTE CON SPINE CONICHE**

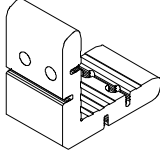

DISEGNO	CODICE	 H x B (MM)	PROFILATO	Da ordinare a parte
	<b>HV2W11</b>	14 x 42.1	C9K020 - - - - C9K030 - - - - C9K120 -	4 x 71C011

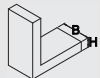
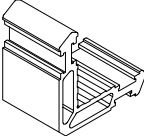
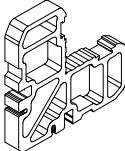
**SQUADRETTE - SQUADRETTE CON ECCENTRICO**



DISEGNO	CODICE	 H x B (MM)	PROFILATO	Da ordinare a parte
	<b>HV0G03</b>	14.5 x 42	C9K020 - - - - C9K030 - - - - C9K120 - - - - - - - - - - - - - - - -	4 x 778-500
	<b>HV3H26</b>	44.5 x 13.2	C9V001 - - - - C9V051 -	2 x 778-500 2 x 71C011

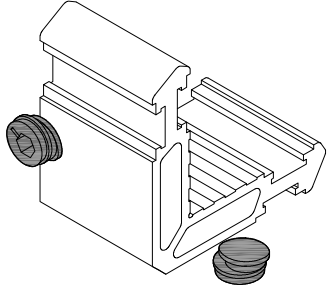
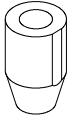
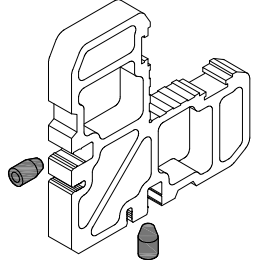

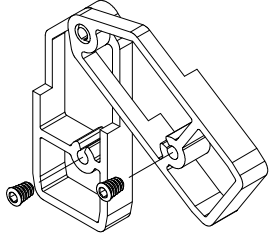
## SQUADRETTE - ACCESSORI PER SQUADRETTE



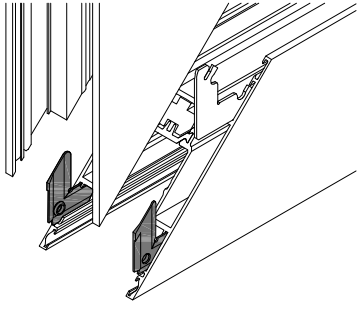

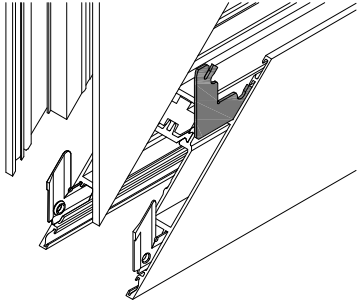

DISEGNO	CODICE	(MM)	DESCRIZIONE	APPLICAZIONE
	<b>778-500</b>		Eccentrico in zama	
	<b>71C011</b>		Spina conica in zama Ø8 x 13.5 mm	
	<b>SCZ810</b>		Vite in acciaio inossidabile	

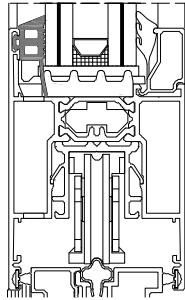

**SQUADRETTE - SQUADRETTE DI ALLINEAMENTO**

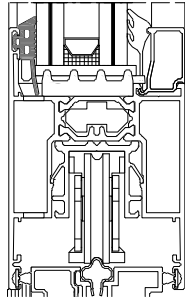
DISEGNO	CODICE	(MM)	DESCRIZIONE	APPLICAZIONE
	<b>HV4K00</b>		Squadretta allineamento in acciaio inossidabile	
	<b>HV4K01</b>		Squadretta allineamento in acciaio inossidabile	

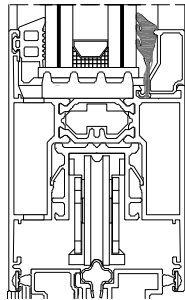

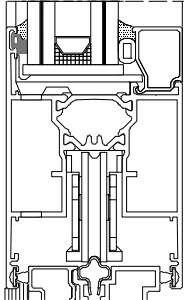
**GUARNIZIONI - FINESTRE**

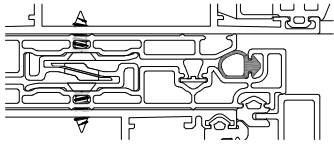

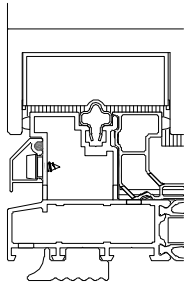

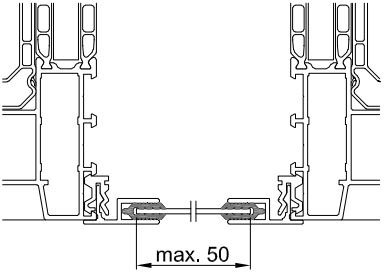
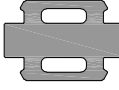
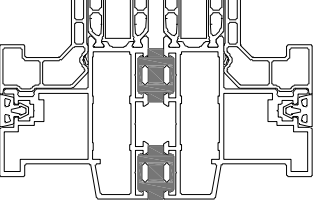

DISEGNO	CODICE	(MM)	DESCRIZIONE	APPLICAZIONE
	<b>RU0002</b>		Guarnizione esterna per vetratura in EPDM nero, spessore 10 mm	
	<b>RU0004</b>		Guarnizione esterna per vetratura in EPDM nero, spessore 6.5 mm	
	<b>39R506</b>	4 - 6 Marcatura blu	Guarnizione interna per vetratura in EPDM nero	
	<b>39R507</b>	6 - 7.5 Marcatura verde		
	<b>39R508</b>	7.5 - 9 Marcatura bianca		
	<b>210-003</b>		Guarnizione esterna per vetratura in EPDM nero	

DISEGNO	CODICE	(MM)	DESCRIZIONE	APPLICAZIONE
	<b>RU9095</b>		Guarnizione tenuta labirinto in EPDM nero	
	<b>213-006</b>		Guarnizione di sigillatura in EPDM nero, Ø4 mm	

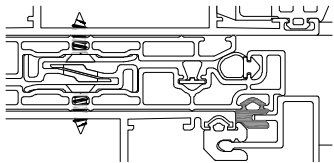

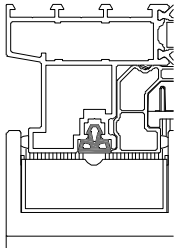
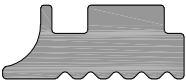
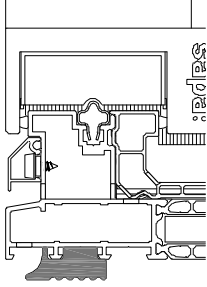
## GUARNIZIONI - VARIE

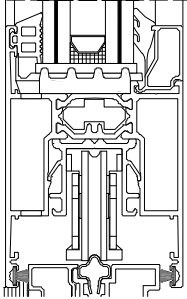
DISEGNO	CODICE	(MM)	DESCRIZIONE	APPLICAZIONE
	<b>71R200</b>		Guarnizione in EPDM giunti dilatazione disponibile in nero	
	<b>RU9022</b>		Guarnizione in EPDM accoppiamento telai disponibile in nero	

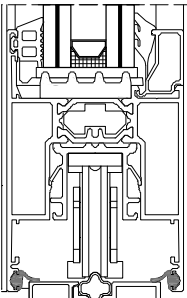
DISEGNO	CODICE	(MM)	DESCRIZIONE	APPLICAZIONE
	<b>RU9703</b>		Guarnizione di posizionamento su labirinto in EPDM nero	
	<b>RU9704</b>		Guarnizione copri-canale in EPDM nero	
	<b>RU9079</b>		Guarnizione soglia in EPDM nero	
	<b>KU6004</b>		Guarnizione tenuta ante in Q-lon nero	
	<b>RU0099</b>		Guarnizione di battuta in EPDM nero	





## GUARNIZIONI - GUARNIZIONI DI SISTEMA



DISEGNO	CODICE	(MM)	DESCRIZIONE	APPLICAZIONE
	<b>RU9094</b>		Guarnizione tenuta ante in EPDM nero	
	<b>RU4033</b>		Guarnizione di battuta in EPDM nero	





## ACCESSORI - FINESTRE

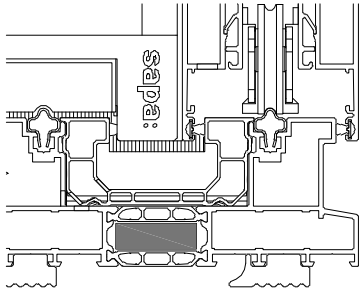

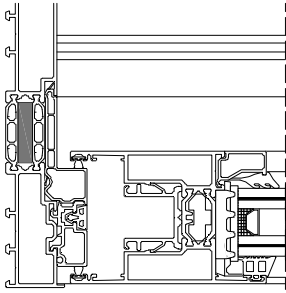

DISEGNO	CODICE	(MM)	DESCRIZIONE	APPLICAZIONE
	<b>VS51' \$</b>		Supporto vetratura, nero	
	<b>KU5001</b>		Profilo PE foam con striscia adesiva per profilato anta	
	<b>BT6000</b>		Isolatore termico in PE foam, in nero	

DISEGNO	CODICE	(MM)	DESCRIZIONE	APPLICAZIONE
	<b>BT6006</b>		Isolatore termico in PE foam, in nero	
	<b>BT6019</b>		Isolatore termico in PE foam, in nero	

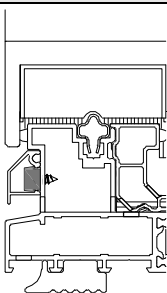
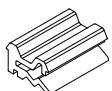
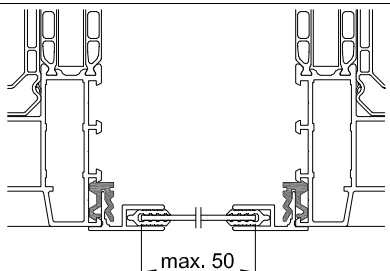

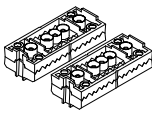
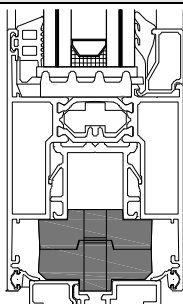
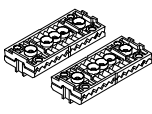
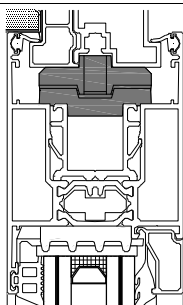
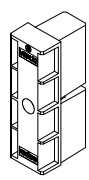
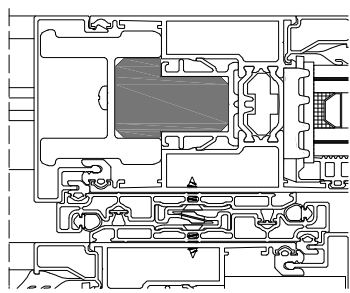

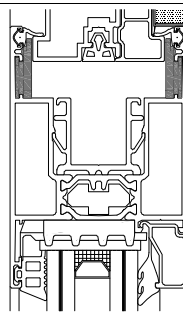

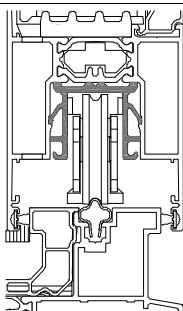
## ACCESSORI - VARIE

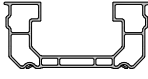
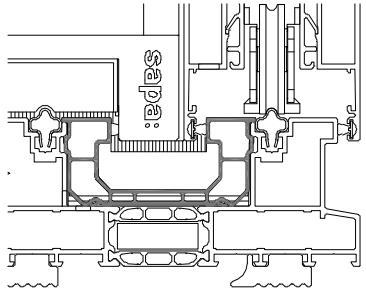

DISEGNO	CODICE	(MM)	DESCRIZIONE	APPLICAZIONE
	<b>CO2279</b>		Clips in alluminio per profilati di finitura	
	<b>71P003</b>		Clips in nylon per profilati di finitura disponibile in nero	

DISEGNO	CODICE	(MM)	DESCRIZIONE	APPLICAZIONE
	<b>VS5128</b>		Supporto inferiore per rendere fissa l'anta alzante-scorrevole	
	<b>VS5129</b>		Supporto superiore per rendere fissa l'anta alzante-scorrevole	
	<b>VS5132</b>		Supporto rinforzo	
	<b>VS5131</b>		Guida anti scarrucolamento	
	<b>KU2027</b>		Profilo di isolamento ferramenta	

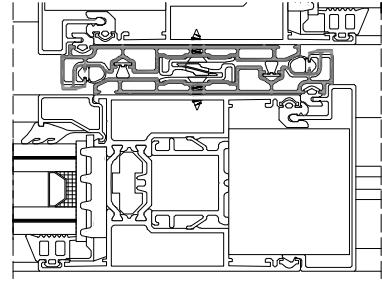

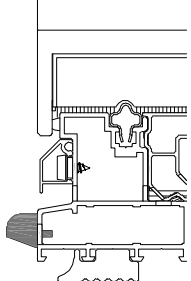
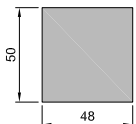
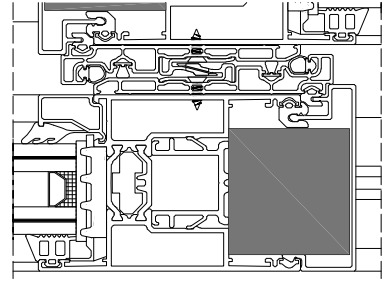
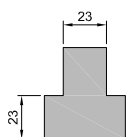
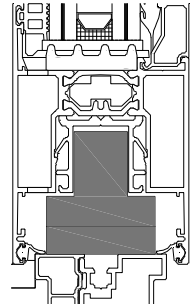
## ACCESSORI - ACCESSORI DI SISTEMA

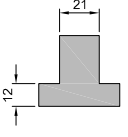
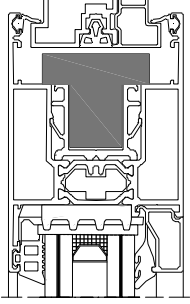

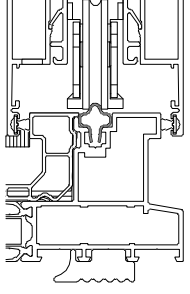
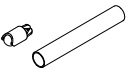
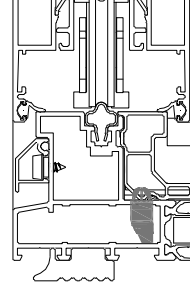
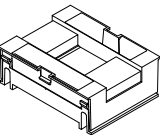
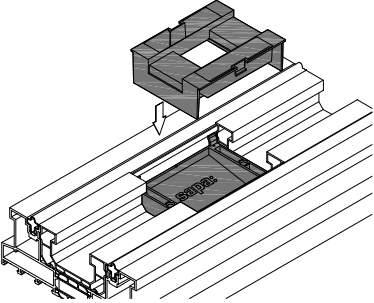
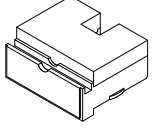
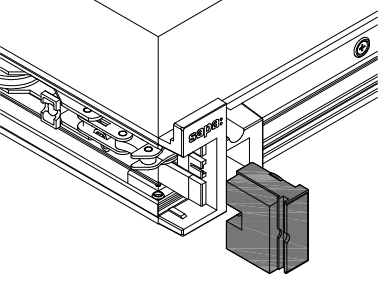

DISEGNO	CODICE	(MM)	DESCRIZIONE	APPLICAZIONE
	<b>KU2028</b>		Profilo di isolamento	
	<b>KU2029</b>		Labirinto centrale isolato	
	<b>D4074009</b>		Cappetta di drenaggio	
	<b>BT6013</b>		Isolante termico in PE foam	
	<b>BT6015</b>		Isolante termico in PE foam	



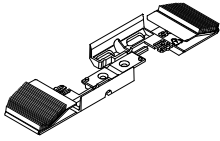
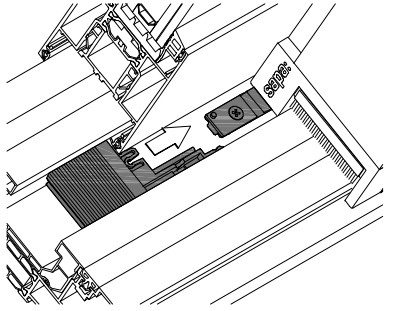
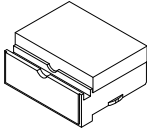
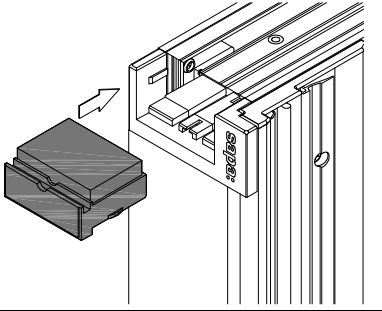
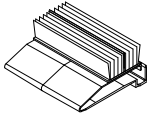
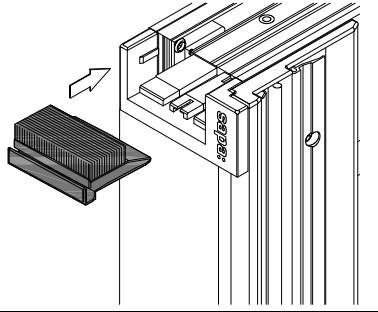

DISEGNO	CODICE	(MM)	DESCRIZIONE	APPLICAZIONE
	<b>BT6026</b>		Isolante termico in PE foam	
	<b>CO1103</b>		Guida in acciaio	
	<b>VS0107</b>		Cappetta di drenaggio con pallina	
	<b>CO1105</b>		Tappo tenuta centrale inferiore	
	<b>CO1127</b>		Tappo tenuta centrale inferiore anta centrale 3 binari (con VS9163)	

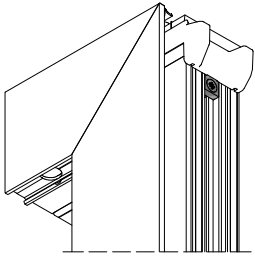

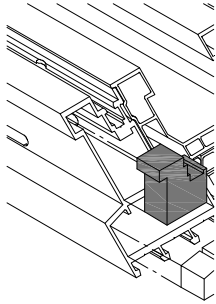

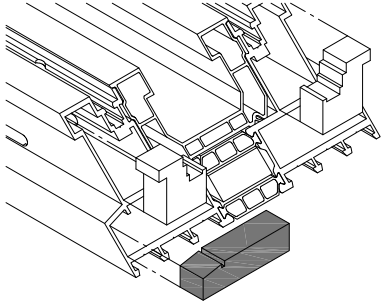
## ACCESSORI - ACCESSORI DI SISTEMA

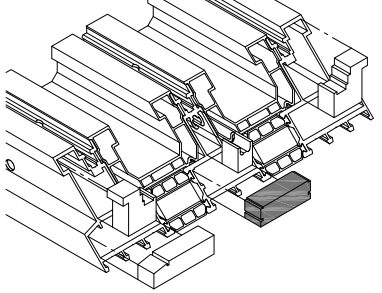

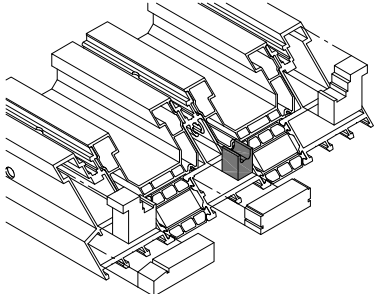
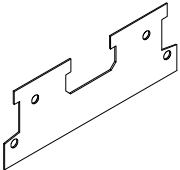
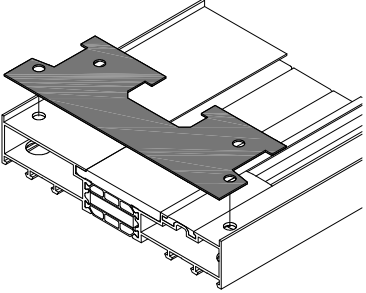
DISEGNO	CODICE	(MM)	DESCRIZIONE	APPLICAZIONE
	<b>CO1111</b>		Tappo di tenuta centrale superiore telaio esterno - alzante-scorrevole	
	<b>CO1107</b>		Tappo tenuta centrale inferiore	
	<b>CO1110</b>		Tappo tenuta centrale profilo labirinto centrale alzante-scorrevole	
	<b>CO1214</b>		Clip per tappo di tenuta	
	<b>VS9950</b>		Tappo di tenuta	

DISEGNO	CODICE	(MM)	DESCRIZIONE	APPLICAZIONE
	<b>VS9951</b>		Tappo di tenuta	
	<b>VS9964</b>		Tappo di tenuta	
	<b>VS9965</b>		Tappo di tenuta	
	<b>VS9956</b>		Tappo di sigillatura sagomato tagli a 90° soglia	

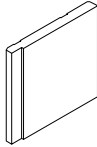
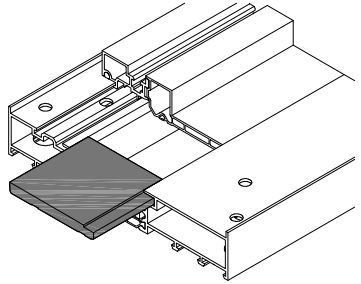
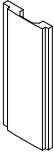
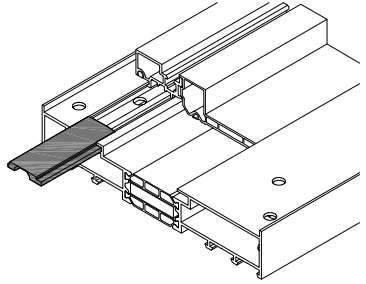
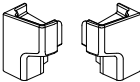
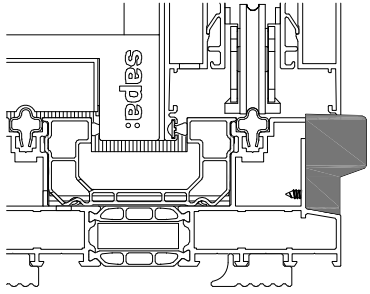
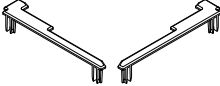
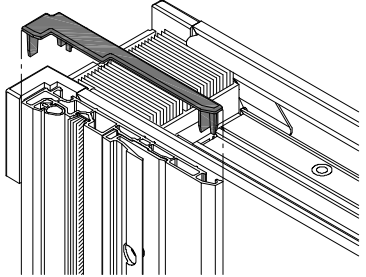
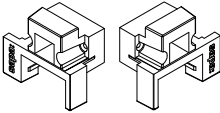
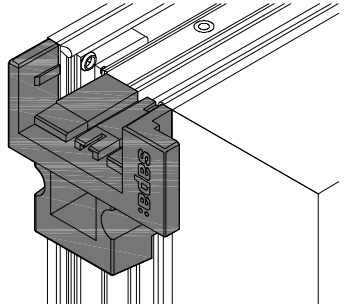

## ACCESSORI - ACCESSORI DI SISTEMA

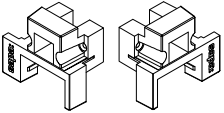
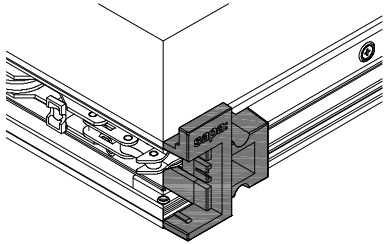
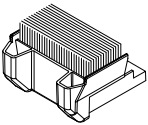
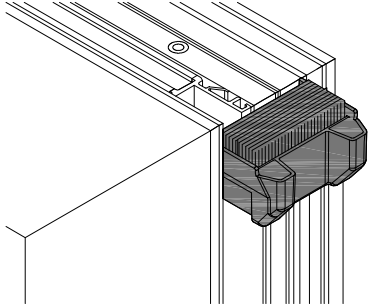
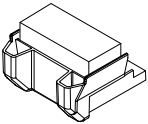
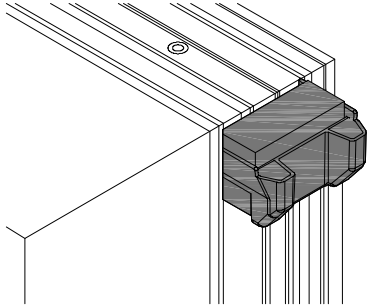
DISEGNO	CODICE	(MM)	DESCRIZIONE	APPLICAZIONE
	<b>VS9957</b>		Tappo di tenuta per tagli a 90°	
	<b>CO0132</b>		Tappo riempimento tagli a 90°	
	<b>VS2404</b>		Tappo terminale per C9A004	
	<b>VS9148</b>		Tappo terminale	
	<b>VS9149</b>		Tappo terminale	

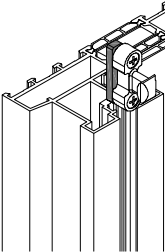
DISEGNO	CODICE	(MM)	DESCRIZIONE	APPLICAZIONE
	<b>VS9163</b>		Tappo terminale (con CO1127)	
	<b>CO1118</b>		Tappo terminale per C9C002	
	<b>CO1125</b>		Tappo di tenuta per C9C002 - Alzante-scorrevole - inferiore	
	<b>CO2211</b>		Spessore	

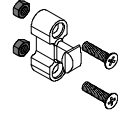
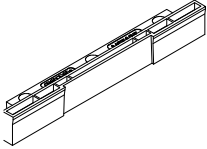
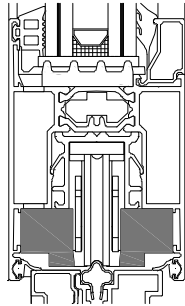
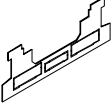
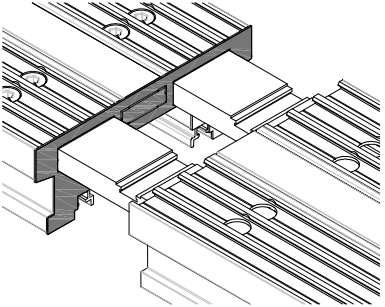
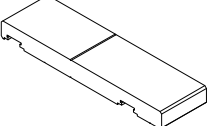
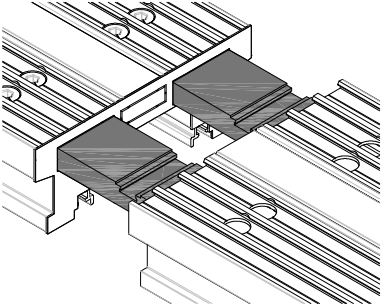

## ACCESSORI - ACCESSORI DI SISTEMA

DISEGNO	CODICE	(MM)	DESCRIZIONE	APPLICAZIONE
	<b>SCG641</b>		Dado - M5 DIN 934	
	<b>VS5135</b>		Blocco centrale alzante-scorrevole	
	<b>VS8002</b>	161.5	Tappo di tenuta per C9K020 / C9K120	
	<b>VS8001</b>	251	Tappo di tenuta per C9K030	
	<b>CO2251</b>		connessione per C9K020 / C9K120 / C9K030	





DIN 916 - ST.ST. - A2	
<b>702-939</b>	M5x5

DIN 7981C - ST.ST. - A2	
<b>787-570</b>	Ø6,3x32

DIN 965 - ST.ST. - A2	
<b>80H520</b>	M5x20

DIN 7982C - ST.ST. - A2	
<b>82L416</b>	Ø4,2x16











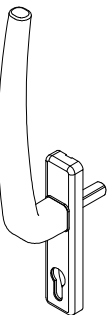

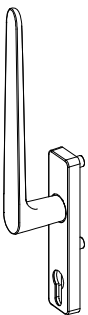

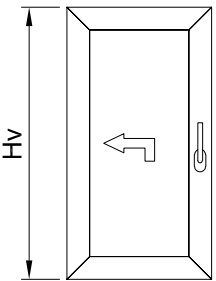
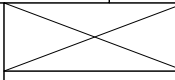
**Selezione ferramenta**

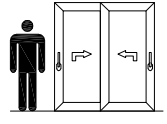
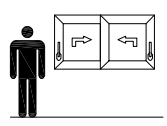
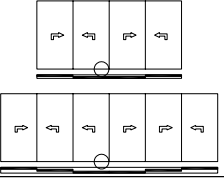
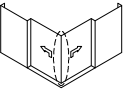



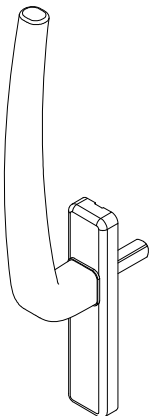
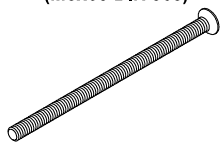

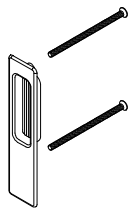
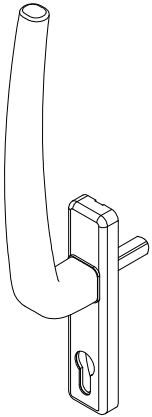
  <b>F.1.2</b>		  <b>F.1.3</b>	
 <b>Hv</b>		<b>Hv</b>	
		1904 - 2803	F.1.5
		2804 - 3403	F.1.6
		1303 - 1903	F.1.4
<b>+</b> 		F.1.8	
<b>+</b> 		F.1.7	

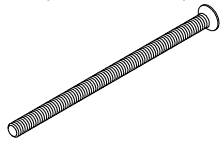
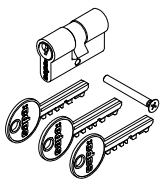
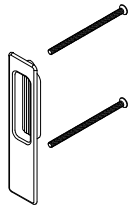
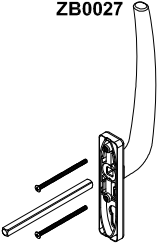
**MANIGLIE STANDARD**

MANIGLIA INTERNA	CILINDRO	MANIGLIA ESTERNA	CHIUSURA SUPPL.
<p>ZB0024</p> 	<p>-</p>	<p>SCE565 x2 (M5x65 DIN 965)</p> 	<p>(Ø5x60)</p> 
		<p>or</p> <p>ZB0028</p> 	
or			
<p>ZB0025</p> 	<p>CYL102</p> 	<p>SCE565 x2 (M5x65 DIN 965)</p> 	<p>-</p>
	<p>CYL318</p> 	<p>or</p> <p>ZB0028</p> 	
or			
		<p>ZB0027</p> 	

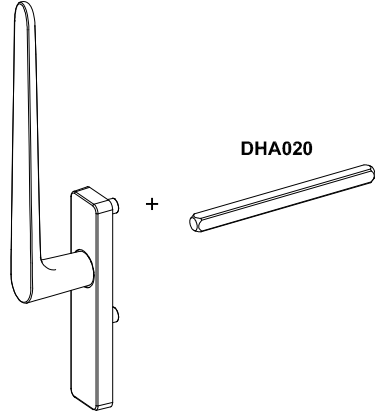
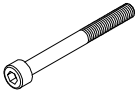
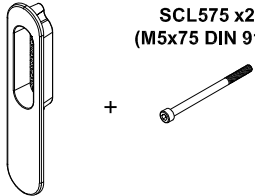
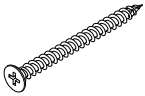
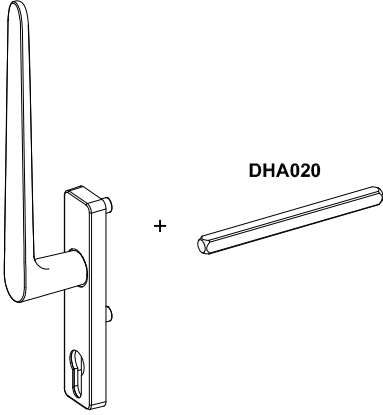
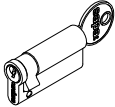
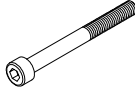
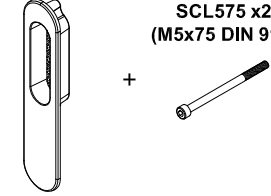
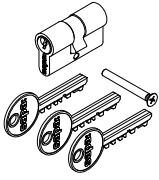
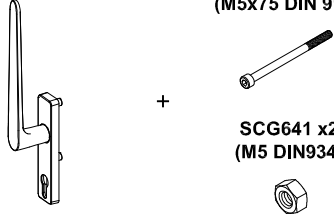
### MANIGLIE S-LINE (HARMONY)

MANIGLIA INTERNA	CILINDRO	MANIGLIA ESTERNA	CHIUSURA SUPPL.
<p>HLH301</p> 	-	<p>SCL550 x2 (M5x50 DIN 912)</p>  <p>or</p> <p>HLH304</p>  <p>SCL575 x2 (M5x75 DIN 912)</p>	<p>(Ø5x60)</p> 
or			
<p>HLH302</p> 	<p>CYL102</p> 	<p>SCL550 x2 (M5x50 DIN 912)</p>  <p>or</p> <p>HLH304</p>  <p>SCL575 x2 (M5x75 DIN 912)</p>	-
	<p>CYL318</p> 	<p>HLH302</p>  <p>SCL575 x2 (M5x75 DIN 912)</p> <p>SCG641 x2 (M5 DIN934)</p> 	

**ALZANTE-SCORREVOLE**

Hv = 1303 - 1903

	<p><b>ZB0048</b></p> <div style="border: 1px solid black; padding: 2px; width: fit-content;">             Hv + Lv ≤ 5258 <b>ZB0049</b> </div> <div style="border: 1px solid black; padding: 2px; width: fit-content;">             Hv + Lv &gt; 5258 <b>ZB0050</b> </div>																				
+																					
<p><b>ZB0033</b></p>	<div style="border: 1px solid black; padding: 2px; width: fit-content;">  = 101 - 200 kg <b>ZB0053</b> </div> <div style="border: 1px solid black; padding: 2px; width: fit-content;">  = 201 - 400 kg <b>ZB0054</b> </div>	<table border="1"> <tr> <td data-bbox="853 694 1125 616"> </td> <td data-bbox="1125 694 1252 616"></td> <td data-bbox="1252 694 1396 616" style="text-align: center;"><b>x5</b></td> </tr> <tr> <td data-bbox="853 616 1125 817"> </td> <td data-bbox="1125 616 1252 817" style="text-align: center;"><b>x5</b></td> <td data-bbox="1252 616 1396 817" style="text-align: center;"><b>x6</b></td> </tr> <tr> <td data-bbox="853 817 1125 952"> <p><b>80H520</b> (M5x20 DIN965)</p> </td> <td data-bbox="1125 817 1252 952" style="text-align: center;"><b>x4</b></td> <td data-bbox="1252 817 1396 952" style="text-align: center;"><b>x6</b></td> </tr> <tr> <td data-bbox="853 952 1125 1041"> <p><b>SCG641</b> (M5 DIN934)</p> </td> <td data-bbox="1125 952 1252 1041" style="text-align: center;"><b>x4</b></td> <td data-bbox="1252 952 1396 1041"></td> </tr> <tr> <td data-bbox="853 1041 1125 1232"> <p><b>CO2211</b></p> </td> <td data-bbox="1125 1041 1252 1232"></td> <td data-bbox="1252 1041 1396 1232" style="text-align: center;"><b>x3</b></td> </tr> <tr> <td data-bbox="853 1232 1125 1433"> <p><b>SF3925</b></p> </td> <td data-bbox="1125 1232 1252 1433"></td> <td data-bbox="1252 1232 1396 1433" style="text-align: center;"><b>x1</b></td> </tr> </table>				<b>x5</b>		<b>x5</b>	<b>x6</b>	<p><b>80H520</b> (M5x20 DIN965)</p>	<b>x4</b>	<b>x6</b>	<p><b>SCG641</b> (M5 DIN934)</p>	<b>x4</b>		<p><b>CO2211</b></p>		<b>x3</b>	<p><b>SF3925</b></p>		<b>x1</b>
		<b>x5</b>																			
	<b>x5</b>	<b>x6</b>																			
<p><b>80H520</b> (M5x20 DIN965)</p>	<b>x4</b>	<b>x6</b>																			
<p><b>SCG641</b> (M5 DIN934)</p>	<b>x4</b>																				
<p><b>CO2211</b></p>		<b>x3</b>																			
<p><b>SF3925</b></p>		<b>x1</b>																			
+																					
+																					
	<p><b>ZB0040</b></p> <p><b>(Ø4.2x45) x2</b> (DIN7982C-H)</p> <p><b>VS5135 x4</b></p> <p><b>(Ø4.8x22) x12</b> (DIN7504N-Z)</p> <p><b>(Ø5x40) x5</b></p>	<div style="border: 1px solid black; padding: 5px;"> <p>Lv = 720 - 1500 <b>ZB0029</b></p> <p>Lv = 1501 - 2000 <b>ZB0030</b></p> <p>Lv = 2001 - 2500 <b>ZB0031</b></p> <p>Lv = 2501 - 3250 <b>ZB0032</b></p> </div> <div style="border: 1px solid black; padding: 2px; width: fit-content; margin-top: 10px;">  ≤ 300 kg         </div> <div style="border: 1px solid black; padding: 2px; width: fit-content; margin-top: 10px;">  = 301 - 400 kg         </div>																			
+																					
<p><b>SV0032</b></p>	<div style="border: 1px solid black; padding: 2px; width: fit-content;">  = 301 - 400 kg         </div> <p><b>VS5135 x4</b></p> <p><b>(Ø4.8x22) x12</b> (DIN7504N-Z)</p> <p><b>(Ø5x40) x4</b></p>	<div style="border: 1px solid black; padding: 2px; width: fit-content;">  = 301 - 400 kg         </div> <div style="border: 1px solid black; padding: 2px; width: fit-content; margin-top: 10px;">             Lv = 1316 - 2096 <b>ZB0029</b>              Lv = 2097 - 2596 <b>ZB0030</b>              Lv = 2597 - 3096 <b>ZB0031</b>              Lv = 3097 - 3846 <b>ZB0032</b> </div>																			

## ALZANTE-SCORREVOLE





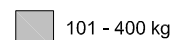
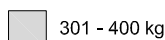





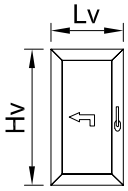
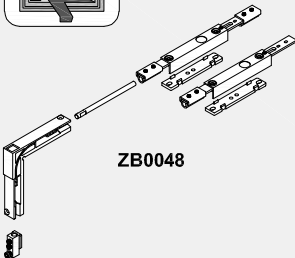



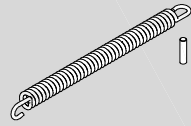

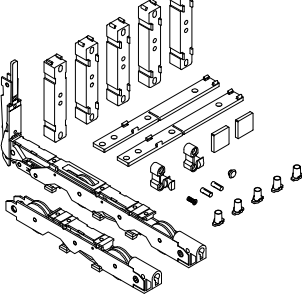
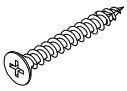
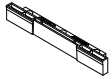

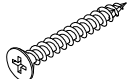
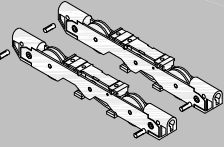
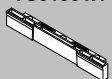

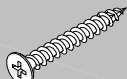

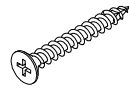

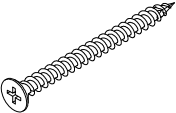

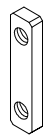
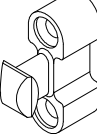

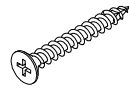
Hv = 1904 - 2803

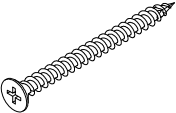
	<p>ZB0048</p> <div style="border: 1px solid black; padding: 2px; width: fit-content;">             Hv + Lv ≤ 5258  <b>ZB0049</b> </div> <div style="border: 1px solid black; padding: 2px; width: fit-content;">             Hv + Lv &gt; 5258  <b>ZB0050</b> </div>		
+		<p>(Ø5x40)</p> <p style="text-align: right;"><b>x5</b></p>	
<div style="border: 1px solid black; padding: 2px; width: fit-content;">             Hv = 1904 - 2203  <b>ZB0034</b> </div> <div style="border: 1px solid black; padding: 2px; width: fit-content;">             Hv = 2204 - 2503  <b>ZB0035</b> </div> <div style="border: 1px solid black; padding: 2px; width: fit-content;">             Hv = 2504 - 2803  <b>ZB0036</b> </div>	<div style="border: 1px solid black; padding: 2px; width: fit-content;">             = 101 - 200 kg  <b>ZB0053</b> </div> <div style="border: 1px solid black; padding: 2px; width: fit-content;">             = 201 - 400 kg  <b>ZB0054</b> </div>	<p>(Ø5x60)</p> <p style="text-align: center;"><b>x8</b></p> <p style="text-align: right;"><b>x9</b></p>	
+		<p><b>80H520</b> (M5x20 DIN965)</p> <p style="text-align: center;"><b>x4</b></p> <p style="text-align: right;"><b>x8</b></p>	
+		<p><b>SCG641 (M5 DIN934)</b></p> <p style="text-align: center;"><b>x4</b></p>	/
+		<p><b>CO2211</b></p> <p style="text-align: right;"><b>x4</b></p>	/
+		+	
<p><b>ZB0040</b></p> <p>(Ø4.2x45) x2 (DIN7982C-H)</p> <p><b>VS5135 x4</b></p> <p>(Ø4.8x22) x12 (DIN7504N-Z)</p> <p>(Ø5x40) x5</p>		+	<div style="border: 1px solid black; padding: 2px; width: fit-content;">             Lv = 720 - 1500  <b>ZB0029</b> </div> <div style="border: 1px solid black; padding: 2px; width: fit-content;">             Lv = 1501 - 2000  <b>ZB0030</b> </div> <div style="border: 1px solid black; padding: 2px; width: fit-content;">             Lv = 2001 - 2500  <b>ZB0031</b> </div> <div style="border: 1px solid black; padding: 2px; width: fit-content;">             Lv = 2501 - 3250  <b>ZB0032</b> </div>
+		<div style="border: 1px solid black; padding: 2px; width: fit-content;">             = 301 - 400 kg         </div> <p><b>SV0032</b></p> <p><b>VS5135 x4</b></p> <p>(Ø4.8x22) x12 (DIN7504N-Z)</p> <p>(Ø5x40) x4</p> <div style="border: 1px solid black; padding: 2px; width: fit-content; margin-top: 10px;">             Lv = 1316 - 2096  <b>ZB0029</b> </div> <div style="border: 1px solid black; padding: 2px; width: fit-content; margin-top: 2px;">             Lv = 2097 - 2596  <b>ZB0030</b> </div> <div style="border: 1px solid black; padding: 2px; width: fit-content; margin-top: 2px;">             Lv = 2597 - 3096  <b>ZB0031</b> </div> <div style="border: 1px solid black; padding: 2px; width: fit-content; margin-top: 2px;">             Lv = 3097 - 3846  <b>ZB0032</b> </div>	

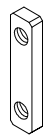
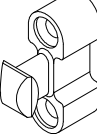

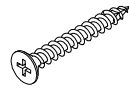
ALZANTE-SCORREVOLE

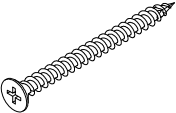

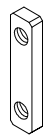
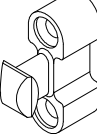
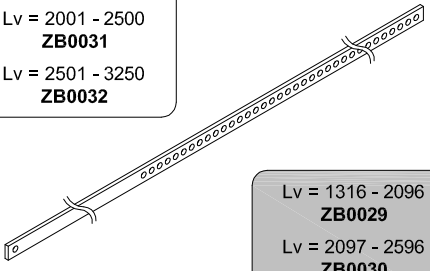
Hv = 2804 - 3403

	 <p>ZB0048</p> <div style="border: 1px solid black; padding: 5px; width: fit-content;"> <p>Hv + Lv ≤ 5258 ZB0049</p> <p>Hv + Lv &gt; 5258 ZB0050</p> </div>																			
+																				
<p>Hv = 2804 - 3103 ZB0035</p> <p>Hv = 3104 - 3403 ZB0036</p>	<p>ZB0046</p>  <p>ZB0045</p> 	<div style="border: 1px solid black; padding: 5px; width: fit-content;"> <p>≤ 101 - 200 kg ZB0053</p> <p>≤ 201 - 400 kg ZB0054</p> </div>  																		
+																				
	<p>ZB0040</p>  <p>(Ø4.2x45) x2 (DIN7982C-H)</p>  <p>VS5135 x4</p>  <p>(Ø4.8x22) x12 (DIN7504N-Z)</p>  <p>(Ø5x40) x5</p> 																			
+																				
<p>SV0032</p>  <div style="border: 1px solid black; padding: 5px; width: fit-content;"> <p>≤ 301 - 400 kg</p> </div> <p>VS5135 x4</p>  <p>(Ø4.8x22) x12 (DIN7504N-Z)</p>  <p>(Ø5x40) x4</p> 																				
+																				
		<table border="1"> <tr> <td data-bbox="901 302 1125 616">  <p>(Ø5x40)</p>  </td> <td data-bbox="1125 302 1252 616" style="text-align: center;">/</td> <td data-bbox="1252 302 1388 616">  <p>x5</p> </td> </tr> <tr> <td data-bbox="901 616 1125 817"> <p>(Ø5x60)</p>  </td> <td data-bbox="1125 616 1252 817" style="text-align: center;">x11</td> <td data-bbox="1252 616 1388 817" style="text-align: center;">x12</td> </tr> <tr> <td data-bbox="901 817 1125 952"> <p>80H520 (M5x20 DIN965)</p>  </td> <td data-bbox="1125 817 1252 952" style="text-align: center;">x6</td> <td data-bbox="1252 817 1388 952" style="text-align: center;">x10</td> </tr> <tr> <td data-bbox="901 952 1125 1041"> <p>SCG641 (M5 DIN934)</p>  </td> <td data-bbox="1125 952 1252 1041" style="text-align: center;">x6</td> <td data-bbox="1252 952 1388 1041" style="text-align: center;">/</td> </tr> <tr> <td data-bbox="901 1041 1125 1232"> <p>CO2211</p>  </td> <td data-bbox="1125 1041 1252 1232" style="text-align: center;">/</td> <td data-bbox="1252 1041 1388 1232" style="text-align: center;">x5</td> </tr> <tr> <td data-bbox="901 1232 1125 1433"> <p>SF3925</p>  </td> <td data-bbox="1125 1232 1252 1433" style="text-align: center;">x1</td> <td data-bbox="1252 1232 1388 1433" style="text-align: center;">x3</td> </tr> </table>	 <p>(Ø5x40)</p> 	/	 <p>x5</p>	<p>(Ø5x60)</p> 	x11	x12	<p>80H520 (M5x20 DIN965)</p> 	x6	x10	<p>SCG641 (M5 DIN934)</p> 	x6	/	<p>CO2211</p> 	/	x5	<p>SF3925</p> 	x1	x3
 <p>(Ø5x40)</p> 	/	 <p>x5</p>																		
<p>(Ø5x60)</p> 	x11	x12																		
<p>80H520 (M5x20 DIN965)</p> 	x6	x10																		
<p>SCG641 (M5 DIN934)</p> 	x6	/																		
<p>CO2211</p> 	/	x5																		
<p>SF3925</p> 	x1	x3																		
		<p>Lv = 720 - 1500 ZB0029</p> <p>Lv = 1501 - 2000 ZB0030</p> <p>Lv = 2001 - 2500 ZB0031</p> <p>Lv = 2501 - 3250 ZB0032</p> <div style="border: 1px solid black; padding: 5px; width: fit-content;"> <p>≤ 300 kg</p> </div>  <div style="border: 1px solid black; padding: 5px; width: fit-content;"> <p>≤ 301 - 400 kg</p> </div> <p>Lv = 1316 - 2096 ZB0029</p> <p>Lv = 2097 - 2596 ZB0030</p> <p>Lv = 2597 - 3096 ZB0031</p> <p>Lv = 3097 - 3846 ZB0032</p>																		



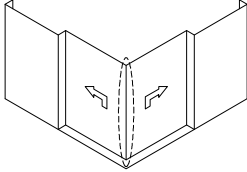
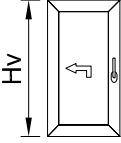

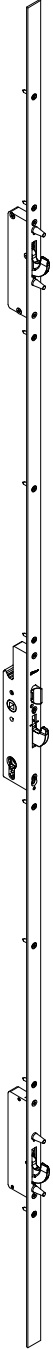
### ANGOLO GALLEGGIANTE

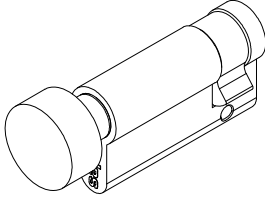
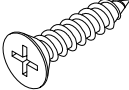
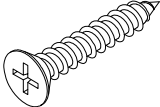
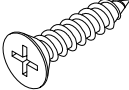
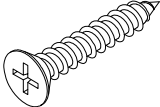
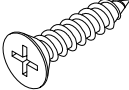
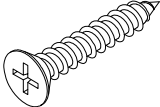
<p>Hv = 2400 - 2550 <b>SF2127</b></p> <p>Hv = 2551 - 2700 <b>SF2129</b></p> 	<p>Hv = 2400 - 2550 <b>SF3066</b></p> <p>Hv = 2551 - 2700 <b>SF3068</b></p> 	<p style="text-align: center;"><b>SF8018</b></p>  <p style="text-align: center;">+</p> <table border="1" style="width: 100%; border-collapse: collapse; margin-top: 20px;"> <thead> <tr> <th rowspan="2"></th> <th colspan="2" style="text-align: center;">Hv</th> </tr> <tr> <th style="text-align: center;">2400 - 2550</th> <th style="text-align: center;">2551 - 2700</th> </tr> </thead> <tbody> <tr> <td style="text-align: center;"> <p><b>82L416</b> (4.2x16) (DIN7982C)</p>  </td> <td style="text-align: center; vertical-align: middle;">x11</td> <td style="text-align: center; vertical-align: middle;">x13</td> </tr> <tr> <td style="text-align: center;"> <p><b>(4.2x16)</b> (DIN7982C)</p>  </td> <td style="text-align: center; vertical-align: middle;">x9</td> <td style="text-align: center; vertical-align: middle;">x10</td> </tr> </tbody> </table>		Hv		2400 - 2550	2551 - 2700	<p><b>82L416</b> (4.2x16) (DIN7982C)</p> 	x11	x13	<p><b>(4.2x16)</b> (DIN7982C)</p> 	x9	x10
	Hv												
	2400 - 2550	2551 - 2700											
<p><b>82L416</b> (4.2x16) (DIN7982C)</p> 	x11	x13											
<p><b>(4.2x16)</b> (DIN7982C)</p> 	x9	x10											

**PEZZI SUPPLEMENTARI**

DISEGNO	CODICE	DESCRIZIONE
	<p><b>ZB0038</b></p>	<p>Punto di chiusura centrale nel caso di ante schema 4 ante, connessione a ZB0040</p>
	<p><b>82L538</b></p>	<p>Viti autofilettanti                      Ø4.8x38 mm                      DIN 7982CHI</p>





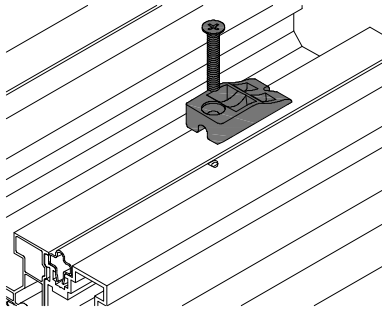
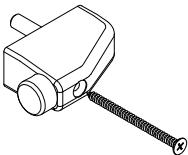
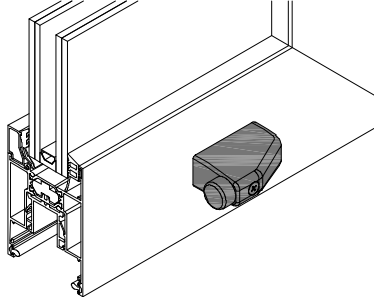
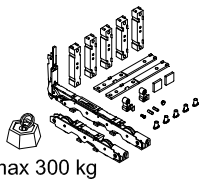
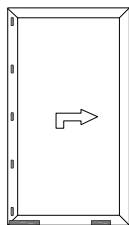
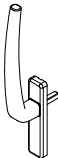
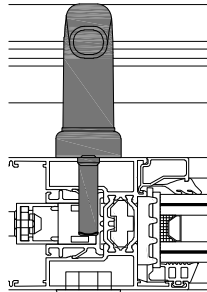
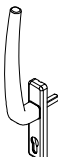
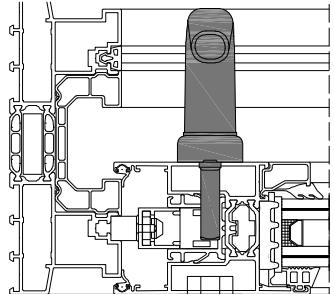

## LISTA ARTICOLI FERRAMENTA

DISEGNO	CODICE	(MM)	DESCRIZIONE	APPLICAZIONE
	<b>ZB0045</b>		Blocchetto supporto ferramenta	
	<b>CYL102</b>		Mezzo cilindro alzante- scorrevole 60/50/10	
	<b>CYL318</b>		Cilindro alzante-scorrevole 100/50/50	
	<b>SF8018</b>		Cilindro angolo galleggiante 35/10	
	<b>SF3925</b>		Parte di bloccaggio alzante- scorrevole	

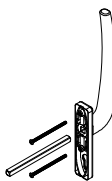
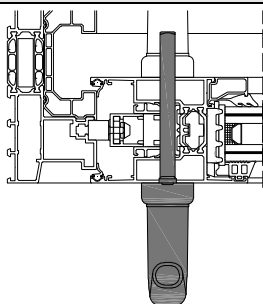
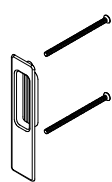
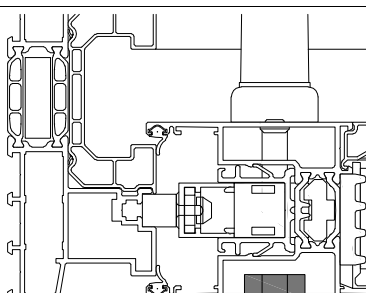

DISEGNO	CODICE	(MM)	DESCRIZIONE	APPLICAZIONE
	<b>ZB0038</b>		Set di bloccaggio	
	<b>SV9002</b>		Paracolpi	
 max 300 kg	<b>ZB0040</b>		Set base alzante-scorrevole	
	<b>ZB0024</b>		Maniglia interna alzante-scorrevole	
	<b>ZB0025</b>		Maniglia interna alzante-scorrevole per cilindro di chiusura	

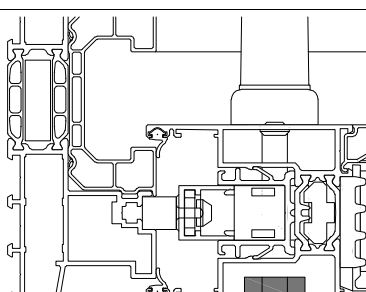

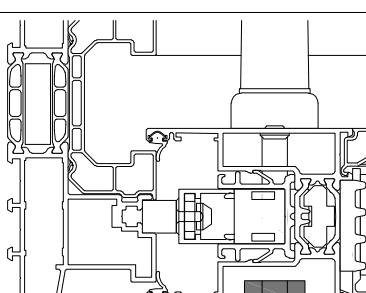
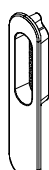
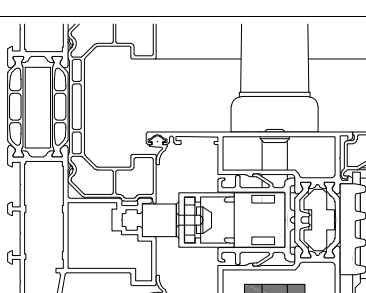



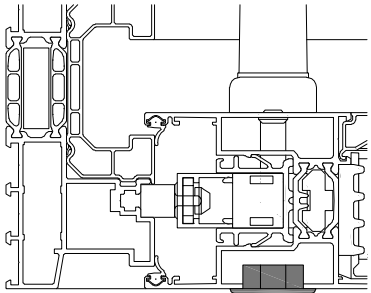
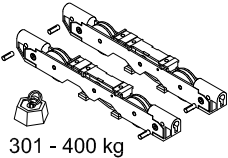
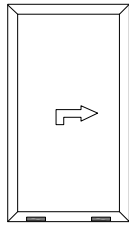
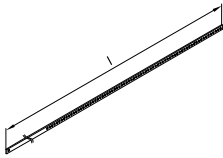
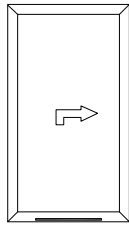
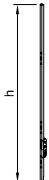
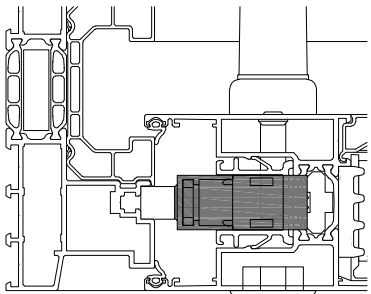

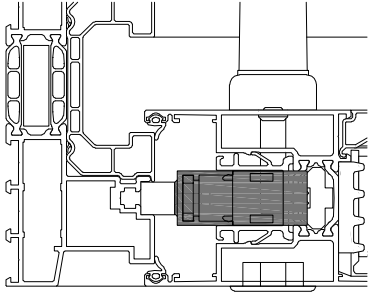
## LISTA ARTICOLI FERRAMENTA

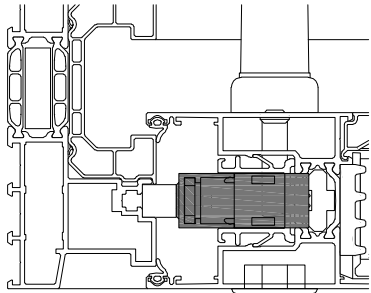

DISEGNO	CODICE	(MM)	DESCRIZIONE	APPLICAZIONE
	<b>ZB0027</b>		Maniglia esterna alzante-scorrevole per cilindro di chiusura	
	<b>ZB0028</b>		Maniglia integrata alzante-scorrevole	
	<b>HLH301</b>		Maniglia interna S-Line alzante-scorrevole design: Harmony	
	<b>HLH302</b>		Maniglia interna/esterna S-Line alzante-scorrevole design: Harmony	
	<b>HLH304</b>		Maniglia integrata S-Line alzante-scorrevole design: Harmony	

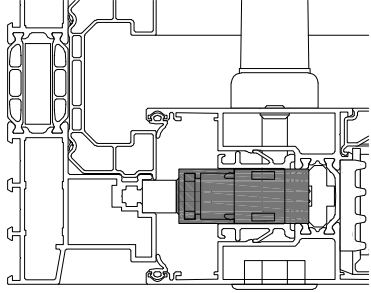
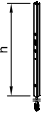
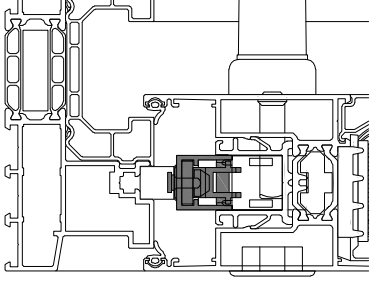
LISTA ARTICOLI FERRAMENTA

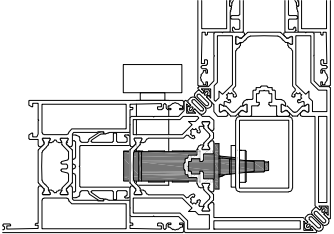
DISEGNO	CODICE	(MM)	DESCRIZIONE	APPLICAZIONE
	<b>DHA020</b>		Maniglia S-Line alzante-scorrevole asta di connessione	
	<b>SV0032</b>		Carrello inferiore supplementare alzante-scorrevole 301-400 kg	
	<b>ZB0029</b>	860	Asta di connessione carrelli alzante-scorrevole	
	<b>ZB0030</b>	1360		
	<b>ZB0031</b>	1860		
	<b>ZB0032</b>	2600		
	<b>ZB0033</b>	1800	Serratura alzante-scorrevole	
	<b>ZB0034</b>	2100	Serratura alzante-scorrevole	

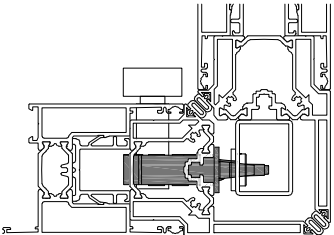
## LISTA ARTICOLI FERRAMENTA

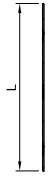
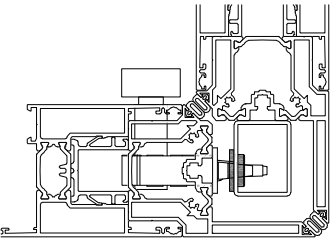
DISEGNO	CODICE	(MM)	DESCRIZIONE	APPLICAZIONE
	<b>ZB0035</b>	2400	Serratura alzante-scorrevole	
	<b>ZB0036</b>	2700	Serratura alzante-scorrevole	
	<b>ZB0046</b>	600	Estensione serratura alzante-scorrevole	
	<b>SF2127</b>	2170	Serratura angolo galleggiante	
	<b>SF2129</b>	2470	Serratura angolo galleggiante	

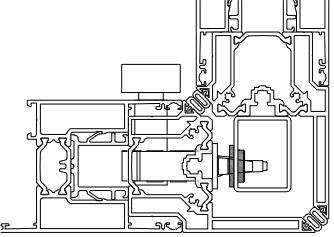
DISEGNO	CODICE	(MM)	DESCRIZIONE	APPLICAZIONE
	<b>SF3066</b>	2170	Chiusura angolo galleggiante	
	<b>SF3068</b>	2470	Chiusura angolo galleggiante	





**Attrezzature**



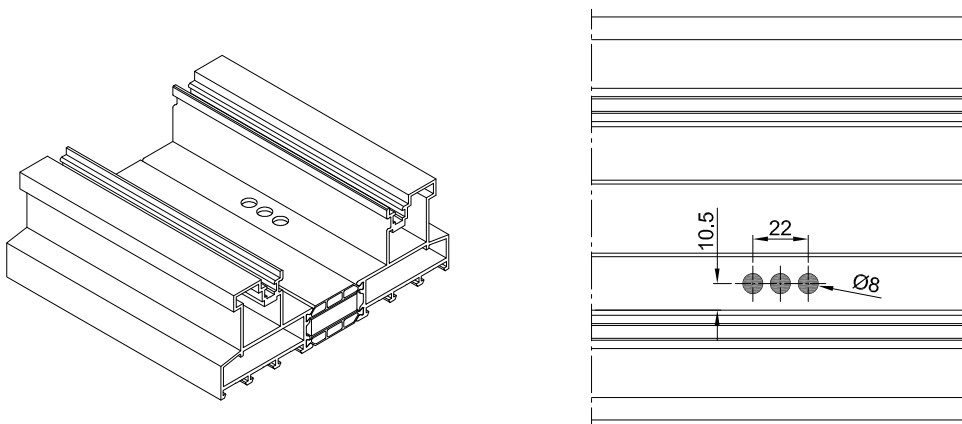
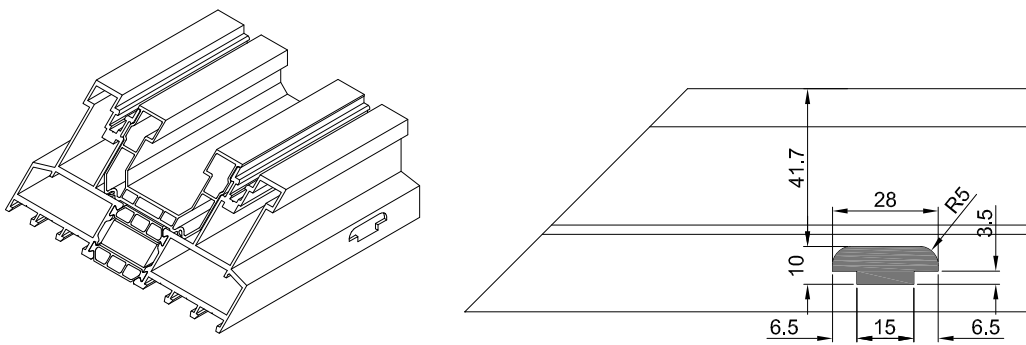
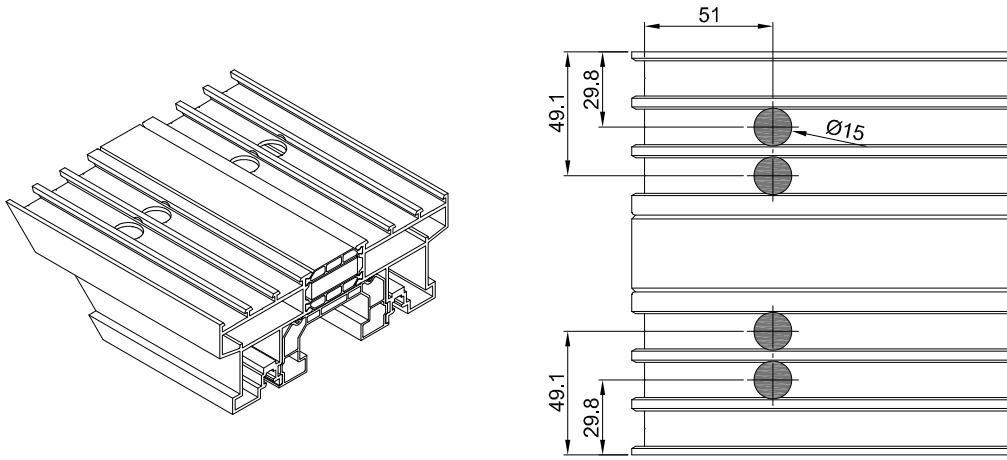

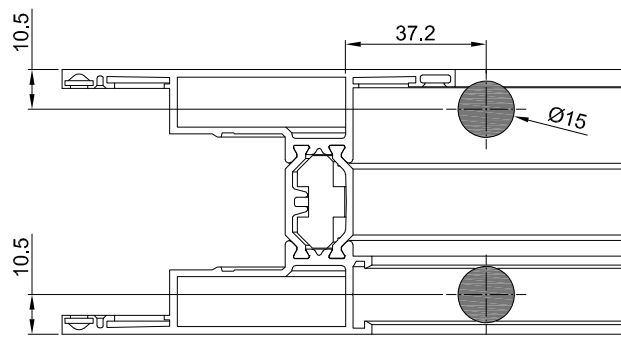
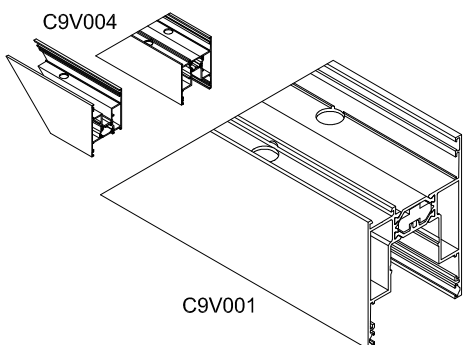
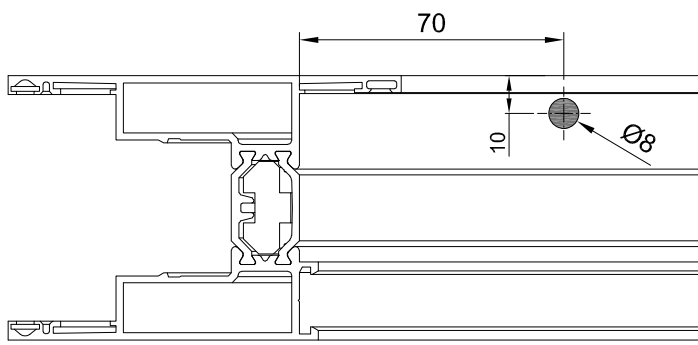
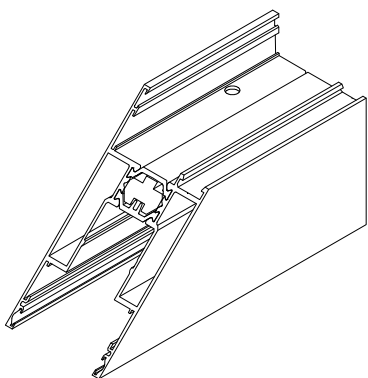
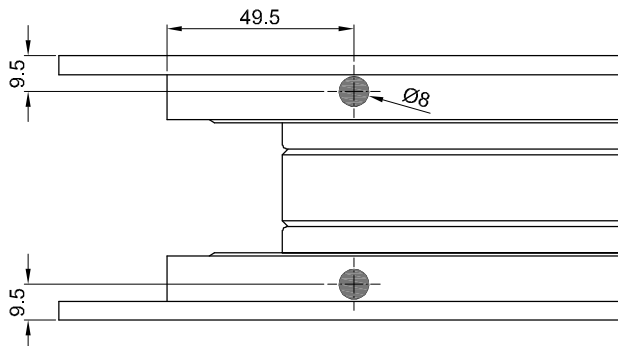
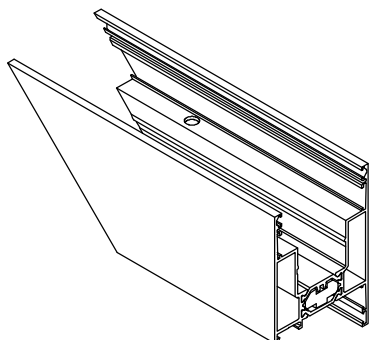

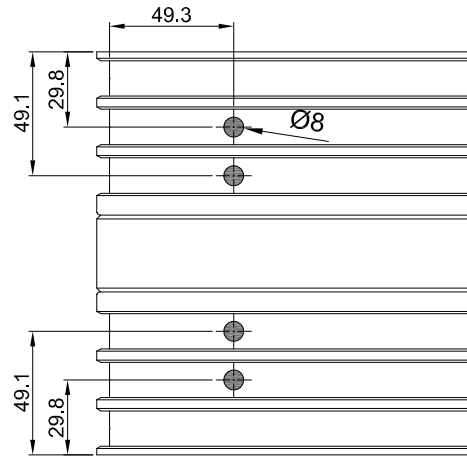
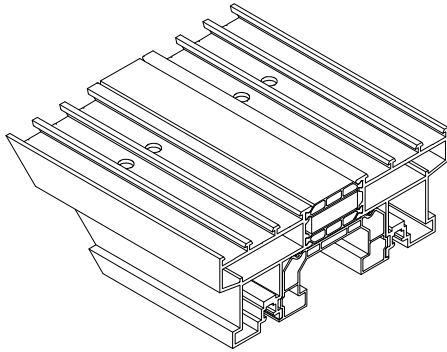





**DIME LAVORAZIONI - PANORAMICA**

TG4116  G.2.2						
		G.2.3			G.2.4	
		G.2.3			G.2.4	
		G.2.3				G.2.5

TG4119  G.2.6	
	G.2.6

Nota: tutte le lavorazioni indicate con le sottoelencate dime sono eseguibili con la punzonatrice D5110000.

**TG4118 - TG4121 - TG4122**

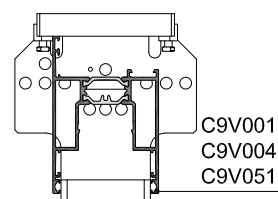
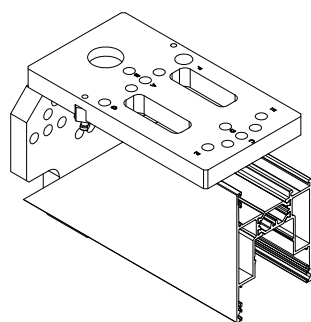
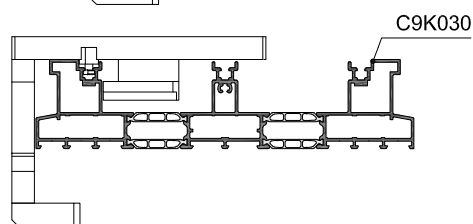
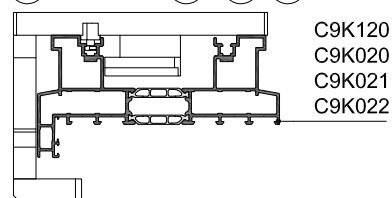
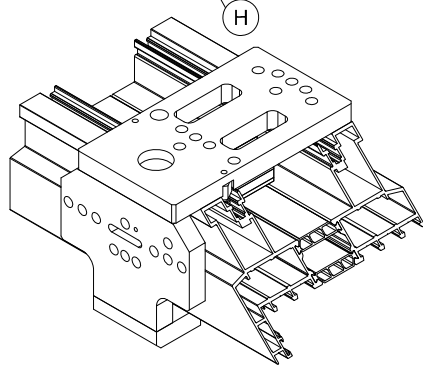
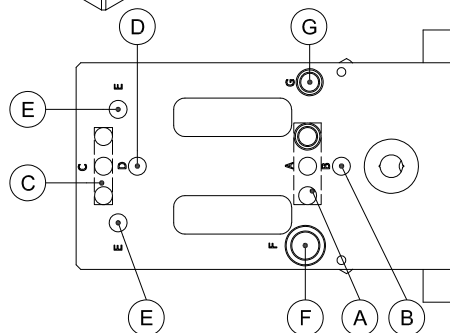
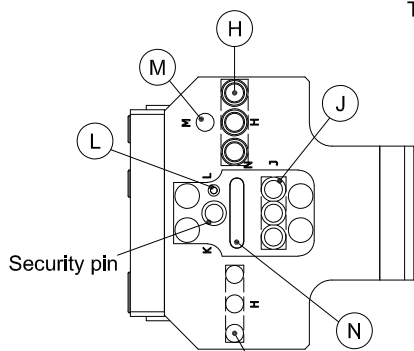
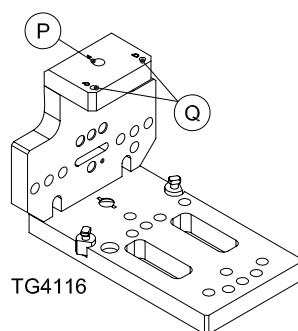

- A drenaggio scarico acqua centrale
- B drenaggio binario
- C drenaggio 3-binari tappo di tenuta centrale
- D drenaggio binario 2 o 3-binari
- E drenaggio anta
- F drenaggio valvola 12 mm
- G drenaggio valvola 9 mm
- H drenaggio binario - Ø8 mm
- J drenaggio binario camera interna
- L clip-vite C9A003
- M drenaggio C9A004
- N drenaggio binario camera interna Ø8 mm
- Q perforazione viti per VS9149 / VS9163 / VS9211 Ø4.2 mm (anta)





**DIME LAVORAZIONI - TG4116**

**C9K020  
A**

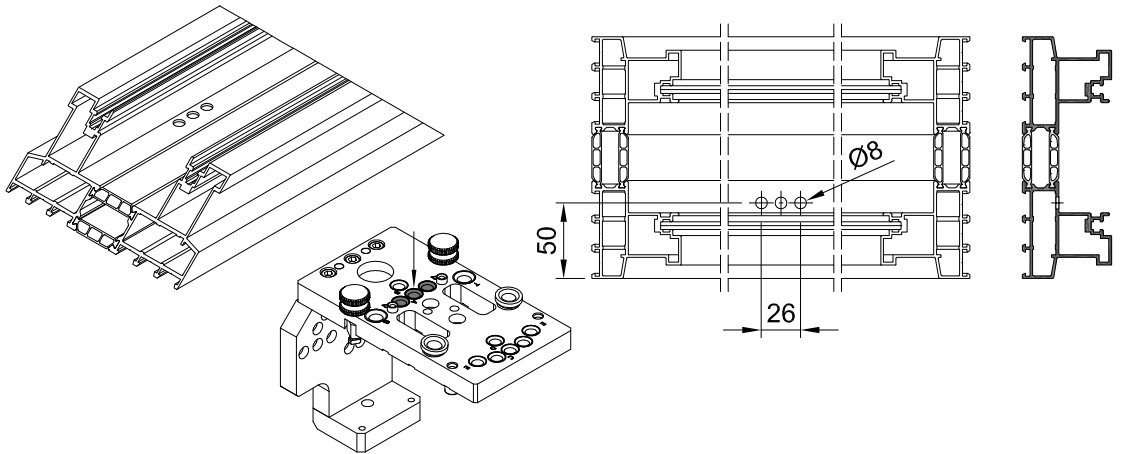

**C9K020  
B**

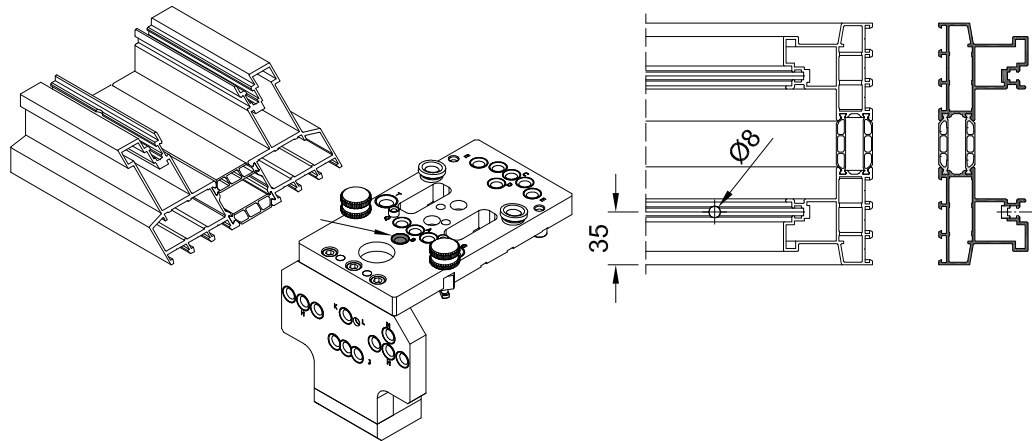

**C9K030  
C**

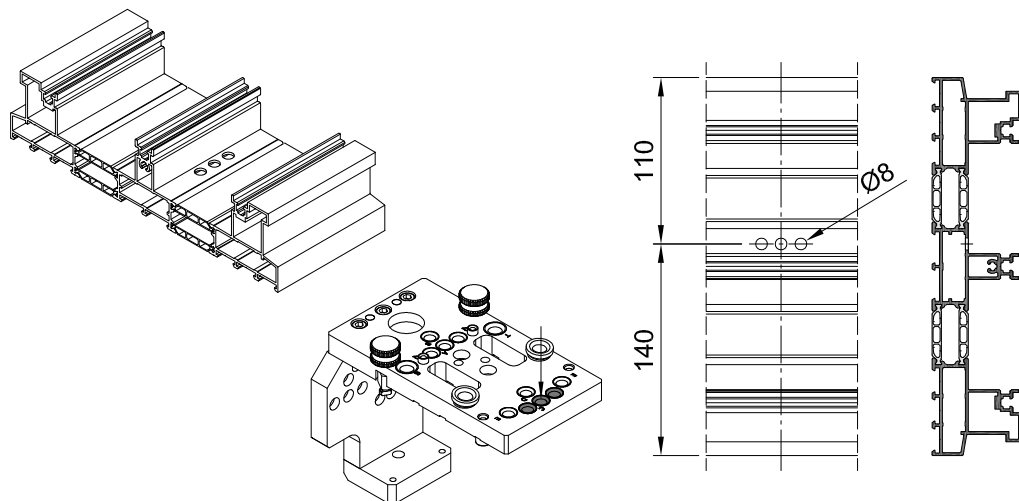

**C9K030  
D**

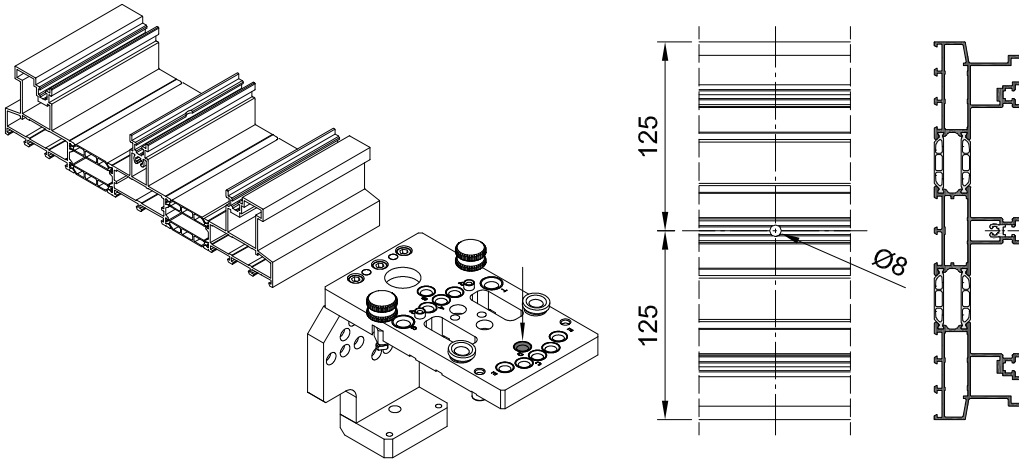

**C9K020  
G**

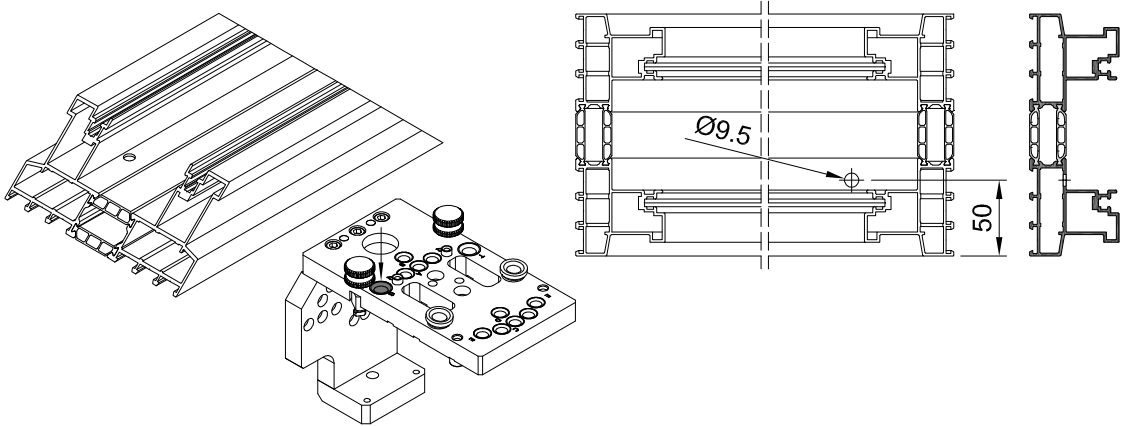

Con VS0107

**C9K020  
H**

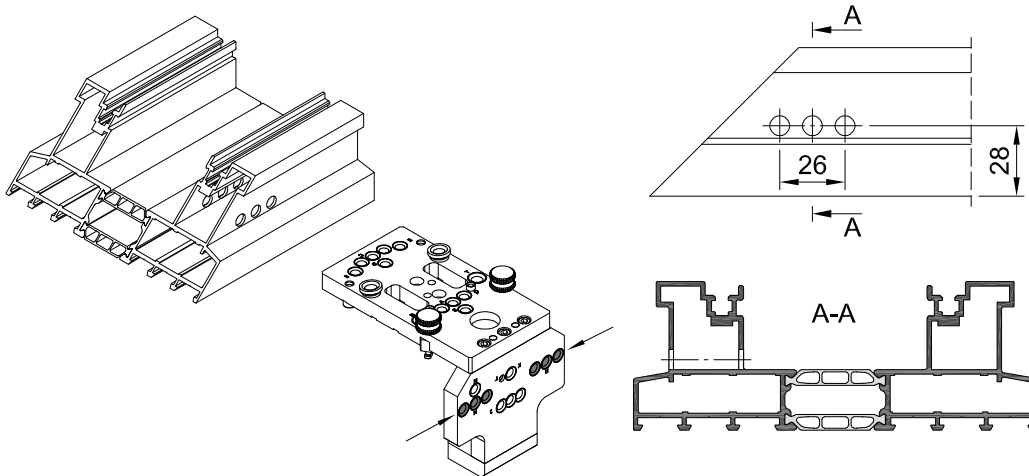



DIME LAVORAZIONI - TG4116

C9K020  
J

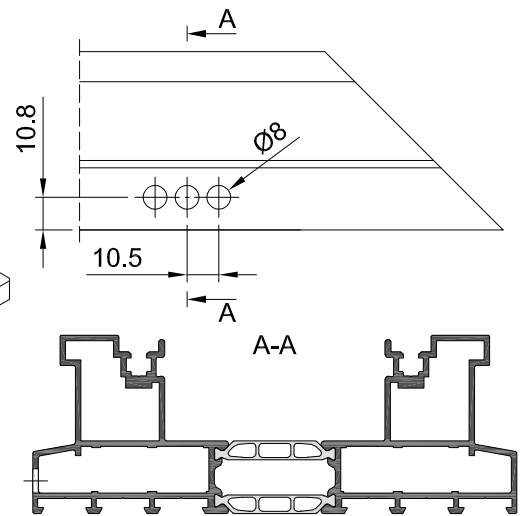
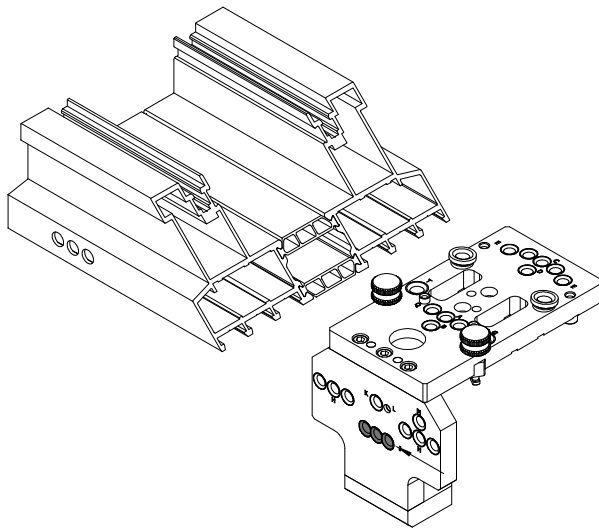

C9K020  
L

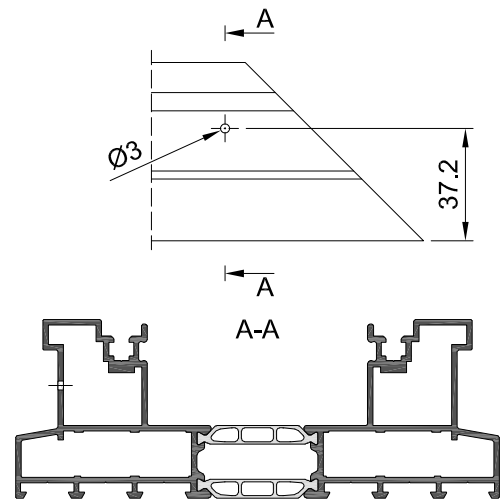
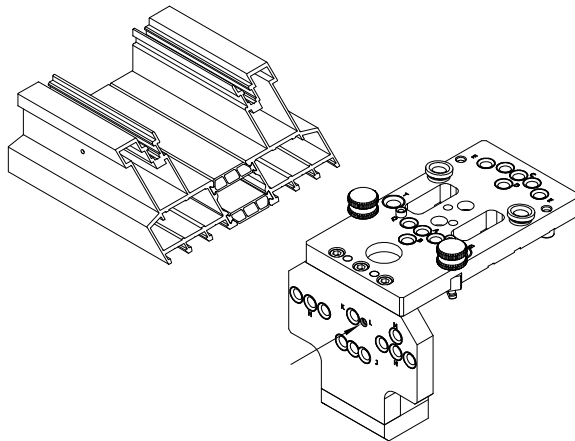

C9K020  
M

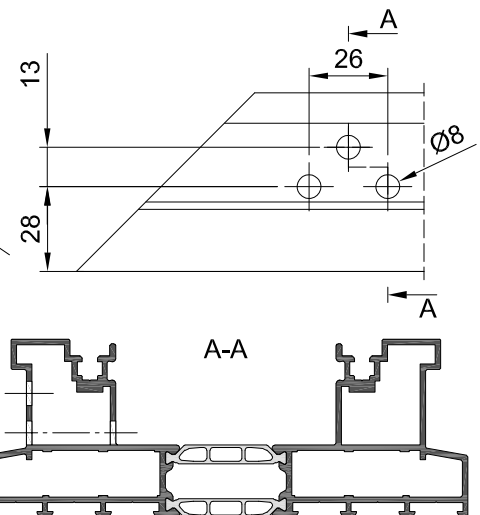
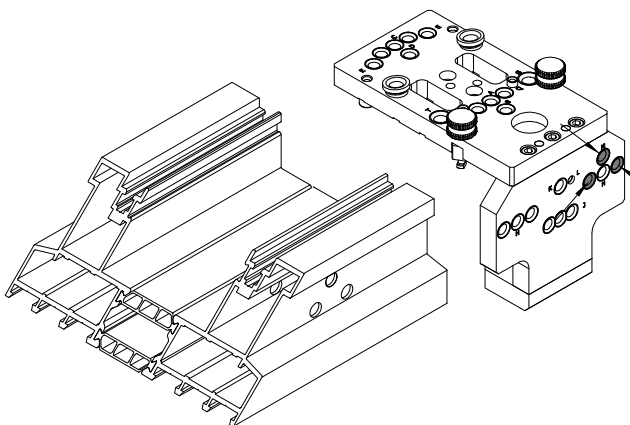

**DIME LAVORAZIONI - TG4116**

C9Vxxx  
Q

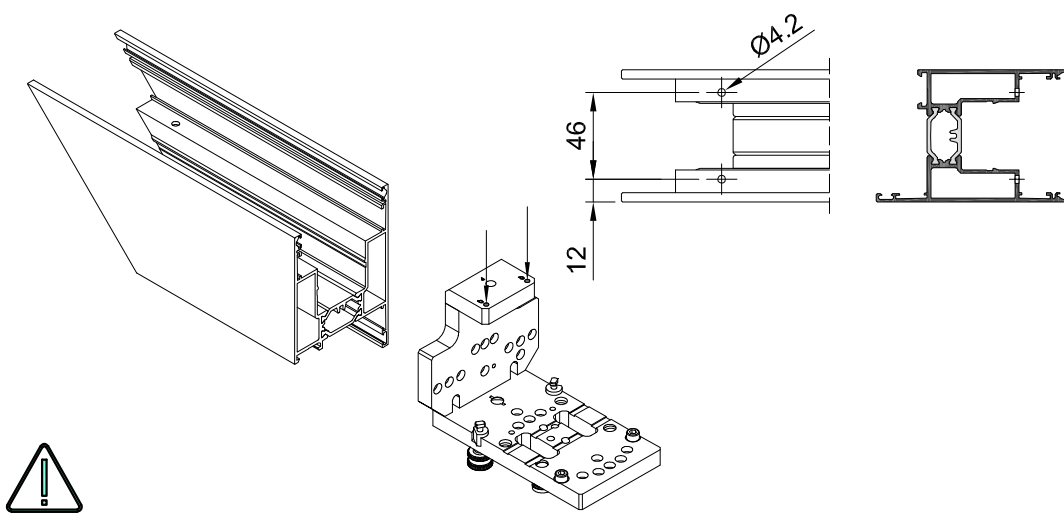

**DIME LAVORAZIONI - TG4119**

C9K120

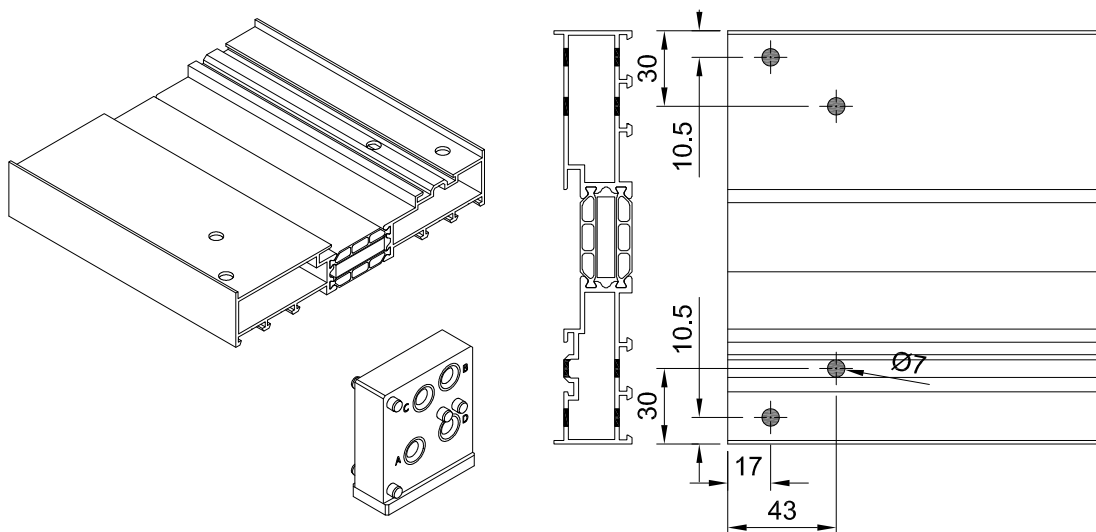



**Nodi**



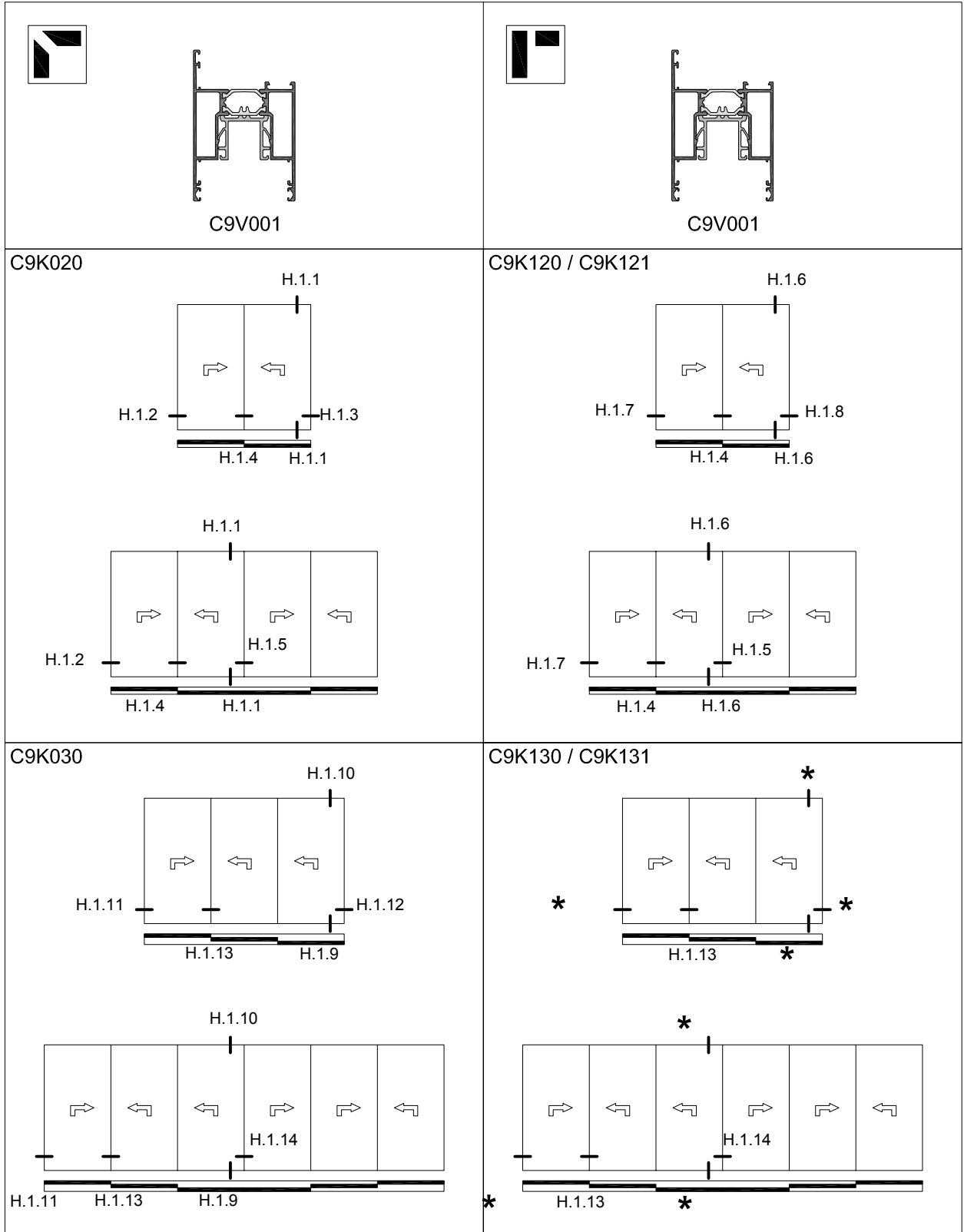

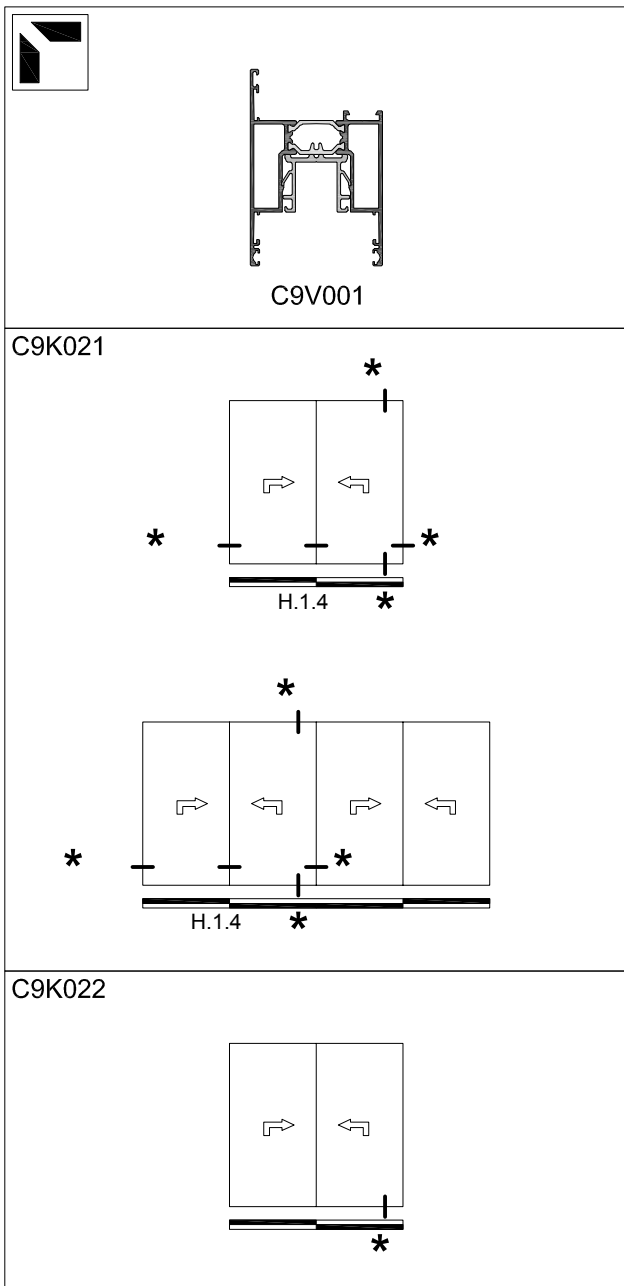



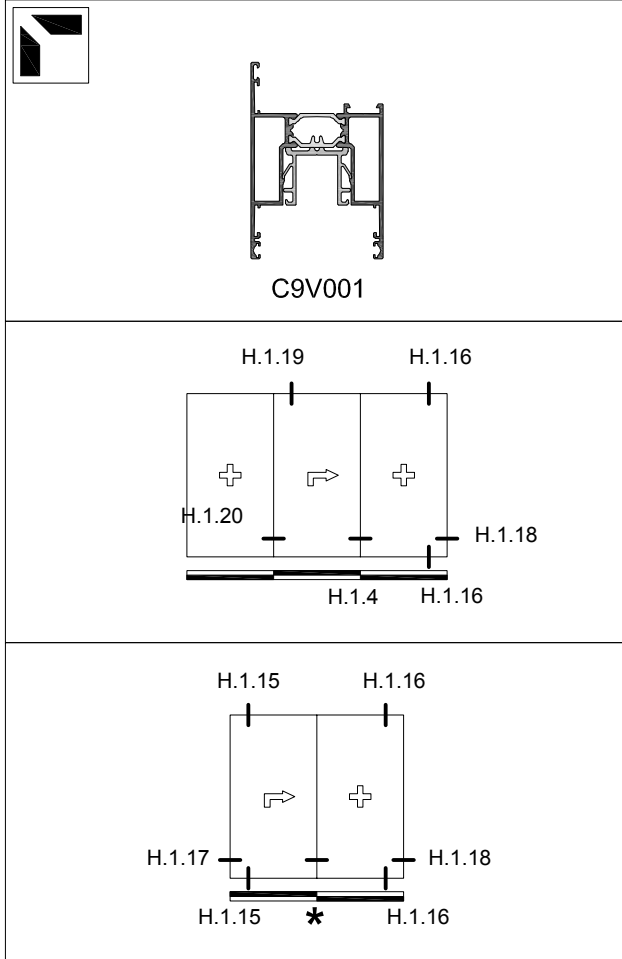

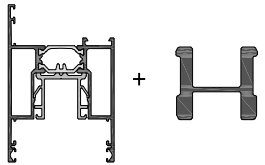
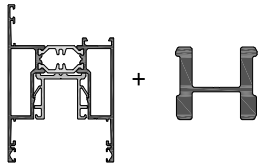
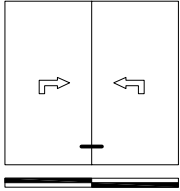
	 <p>C9V001    C9C001</p>		 <p>C9V051    C9C001</p>
	H.1.21		<p>*</p> <p>H.1.22</p>





**ALZANTE-SCORREVOLE C9V001-C9K020 - SUPERIORE DESTRO**

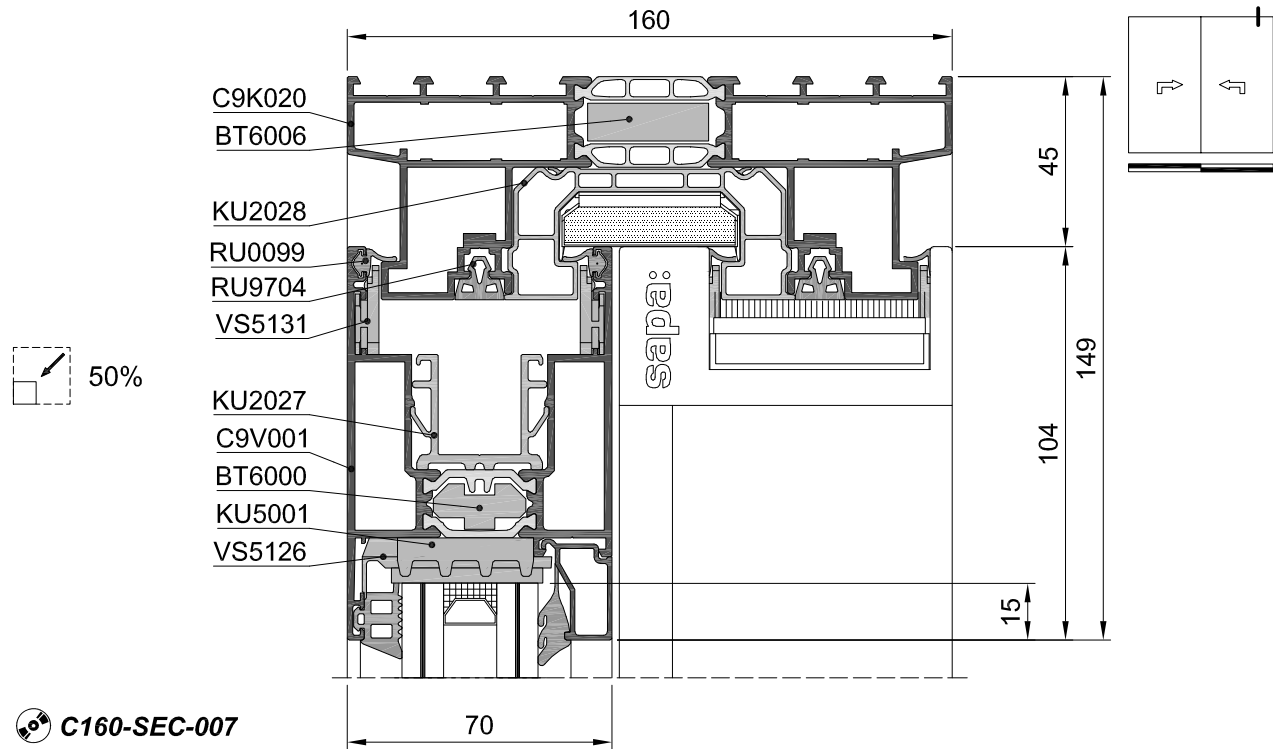

**ALZANTE-SCORREVOLE C9V001-C9K020 - INFERIORE DESTRO**

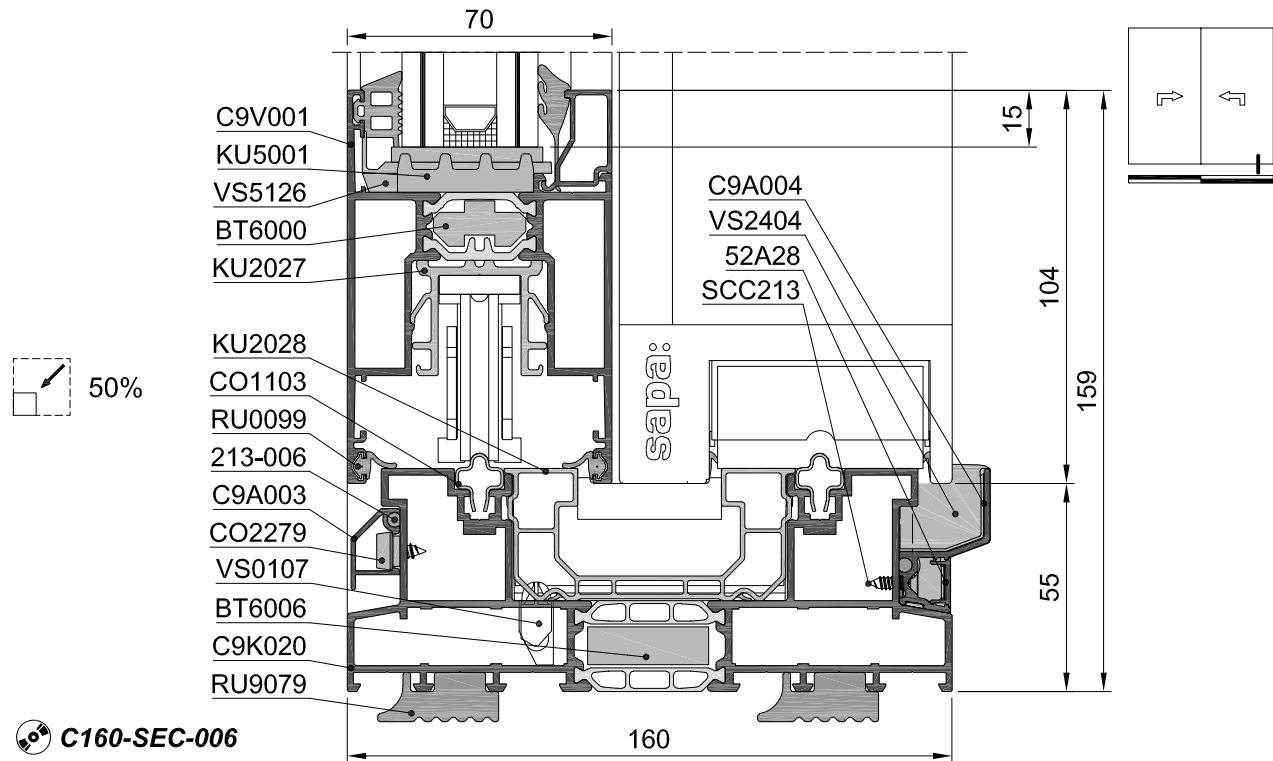

**ALZANTE-SCORREVOLE C9V001-C9K020 - SINISTRO**

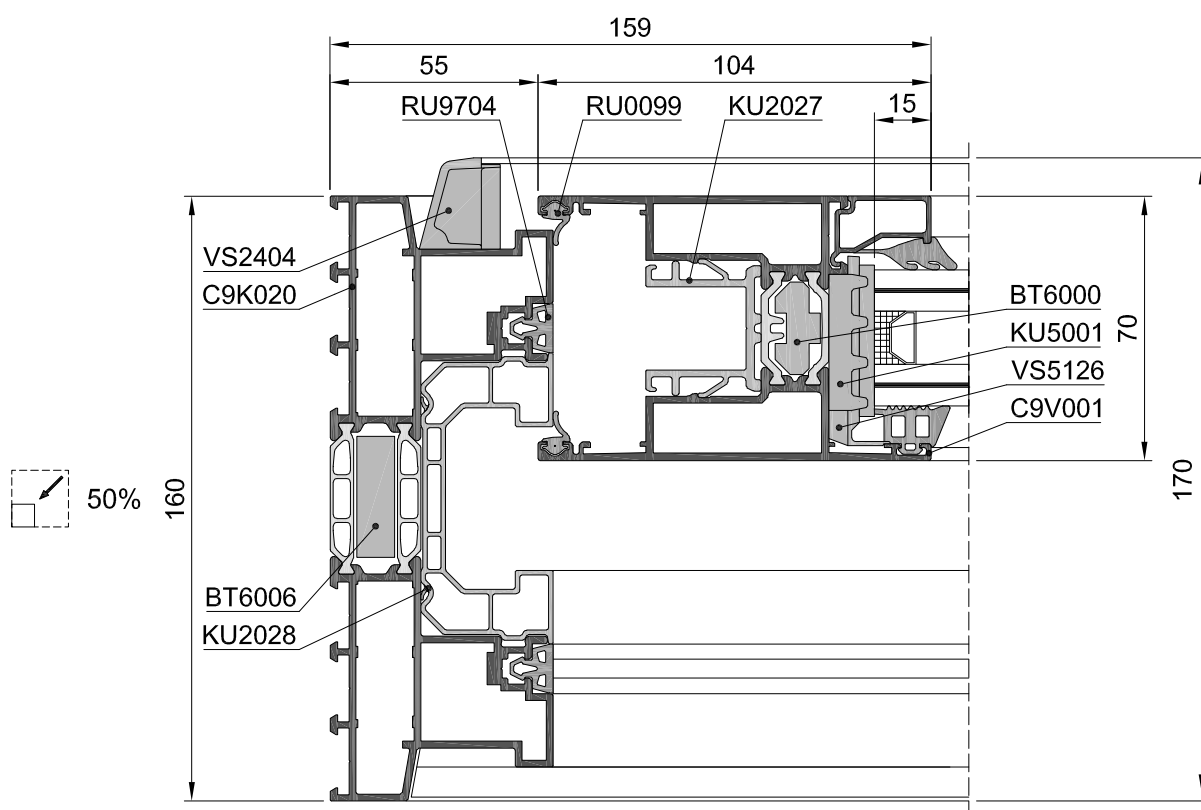
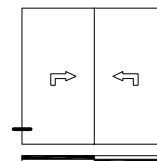

ALZANTE-SCORREVOLE C9V001-C9K020 - DESTRO

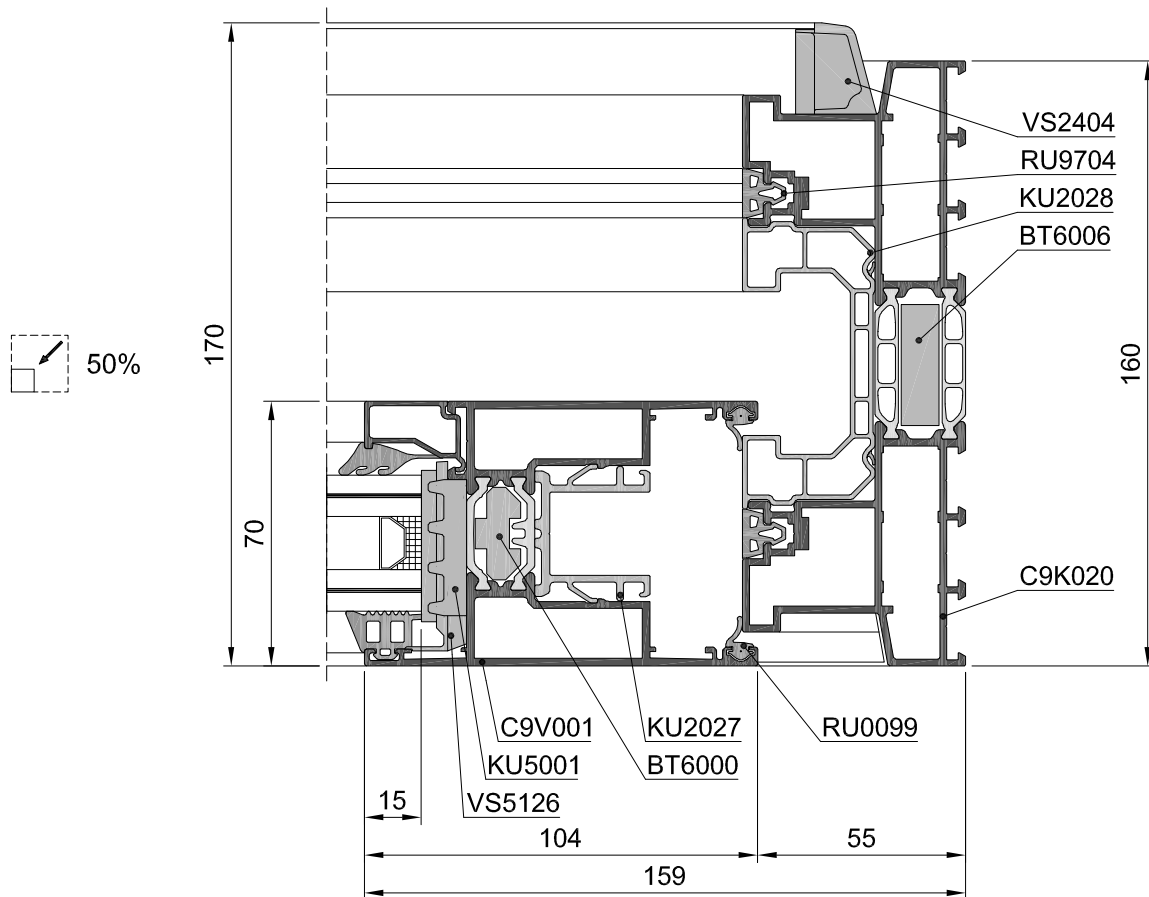
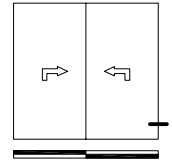

**ALZANTE-SCORREVOLE C9V001-C9K020 - CENTRALE**

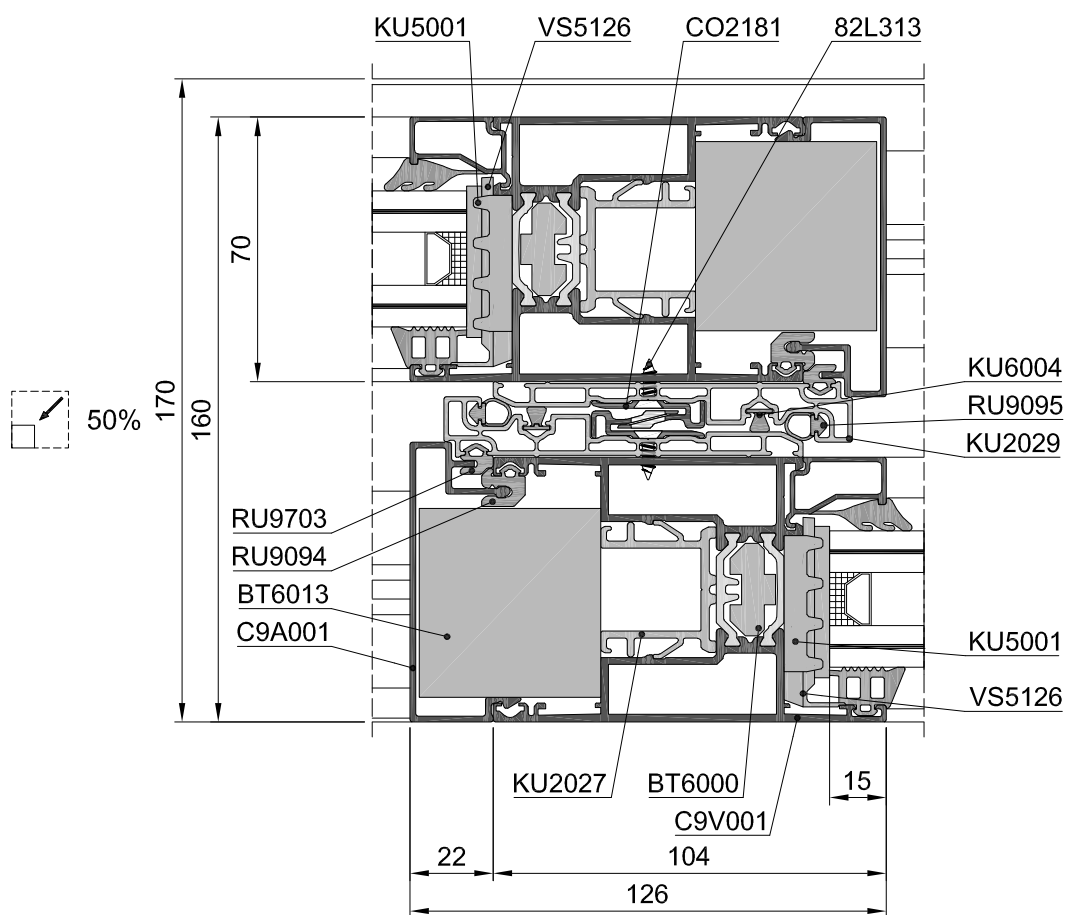
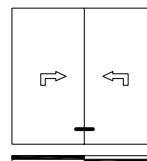



**ALZANTE-SCORREVOLE C9V001-C9K020 - CENTRALE**

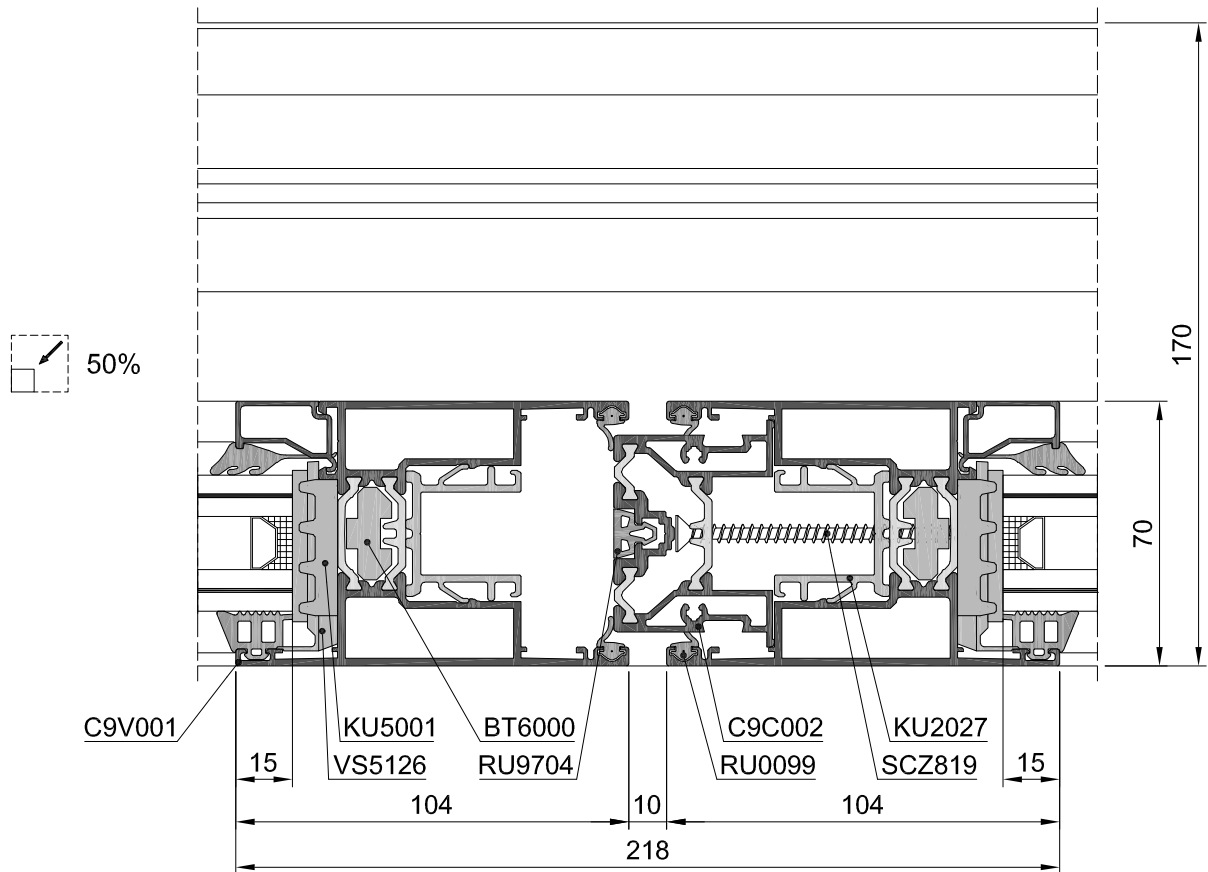
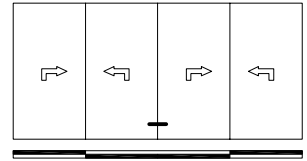

**ALZANTE-SCORREVOLE C9V001-C9K120/C9K121 - SUPERIORE DESTRO**

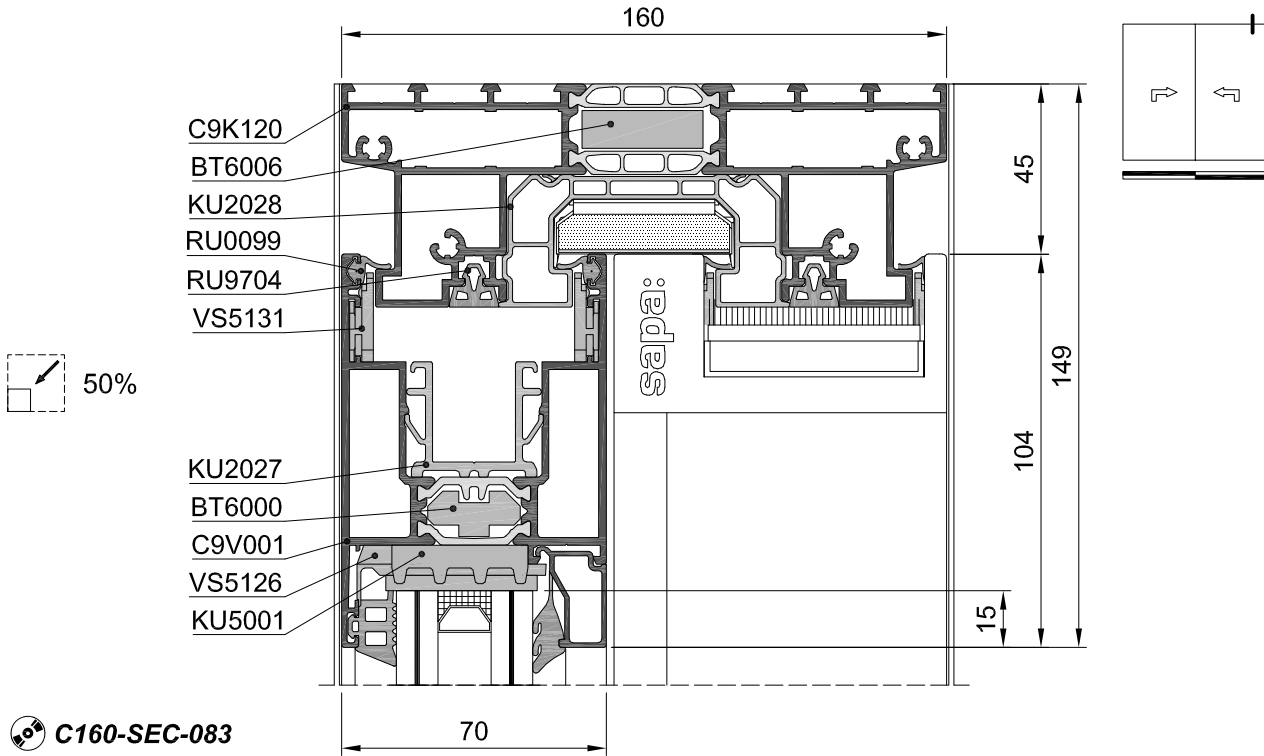

**ALZANTE-SCORREVOLE C9V001-C9K120/C9K121 - INFERIORE DESTRO**

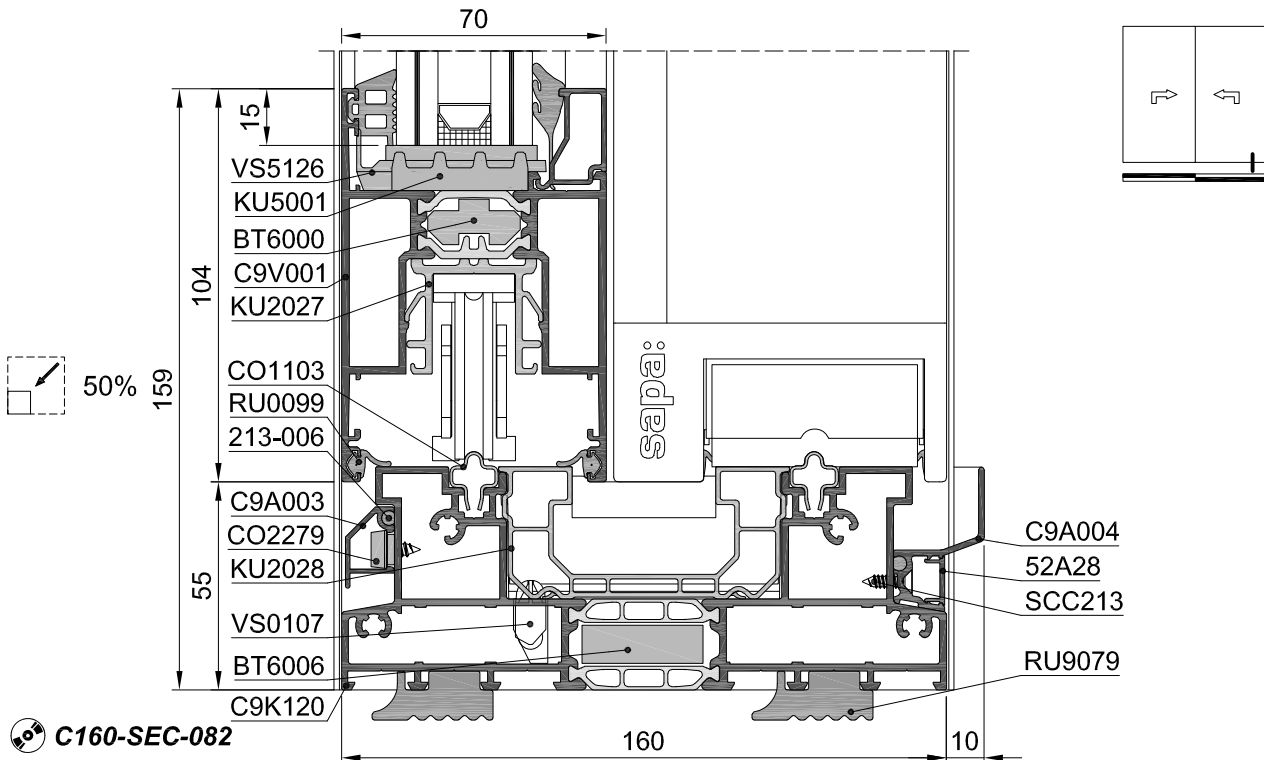

ALZANTE-SCORREVOLE C9V001-C9K120/C9K121 - SINISTRO

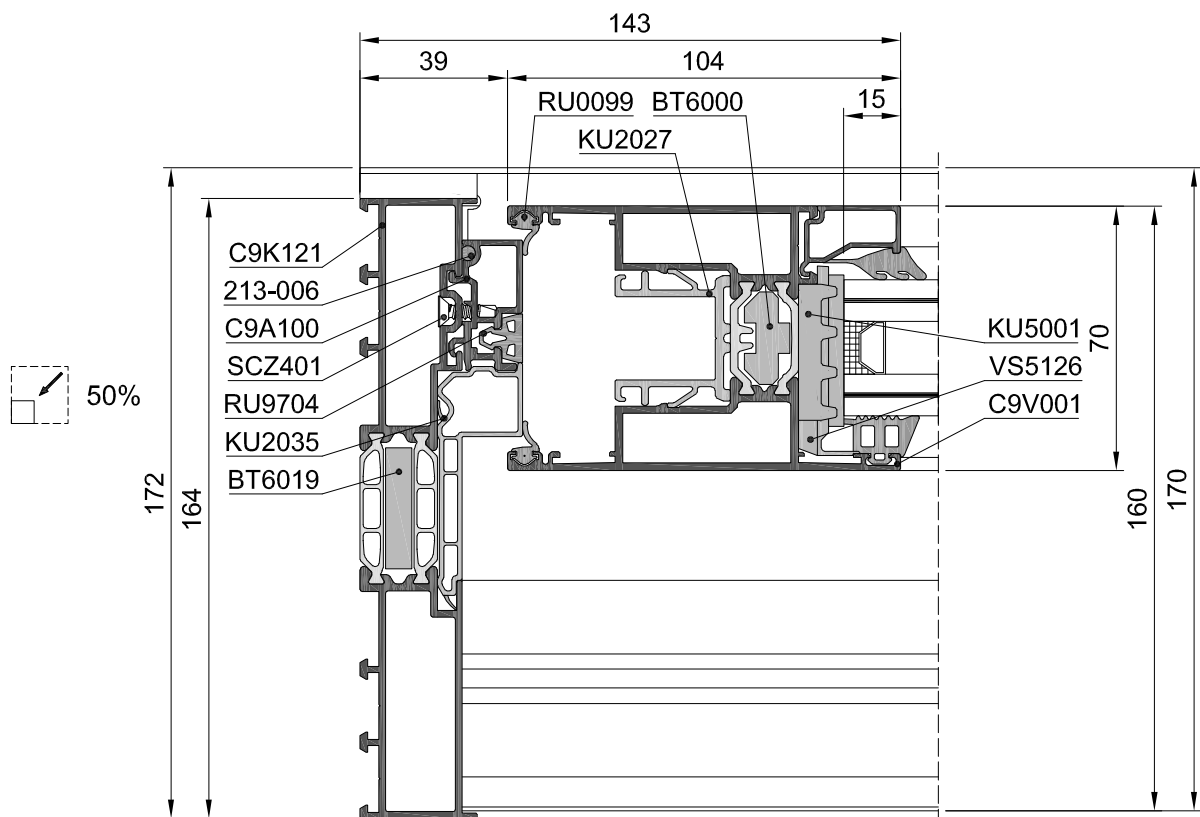
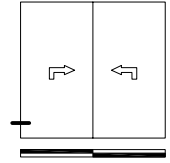

**ALZANTE-SCORREVOLE C9V001-C9K120/C9K121 - DESTRO**

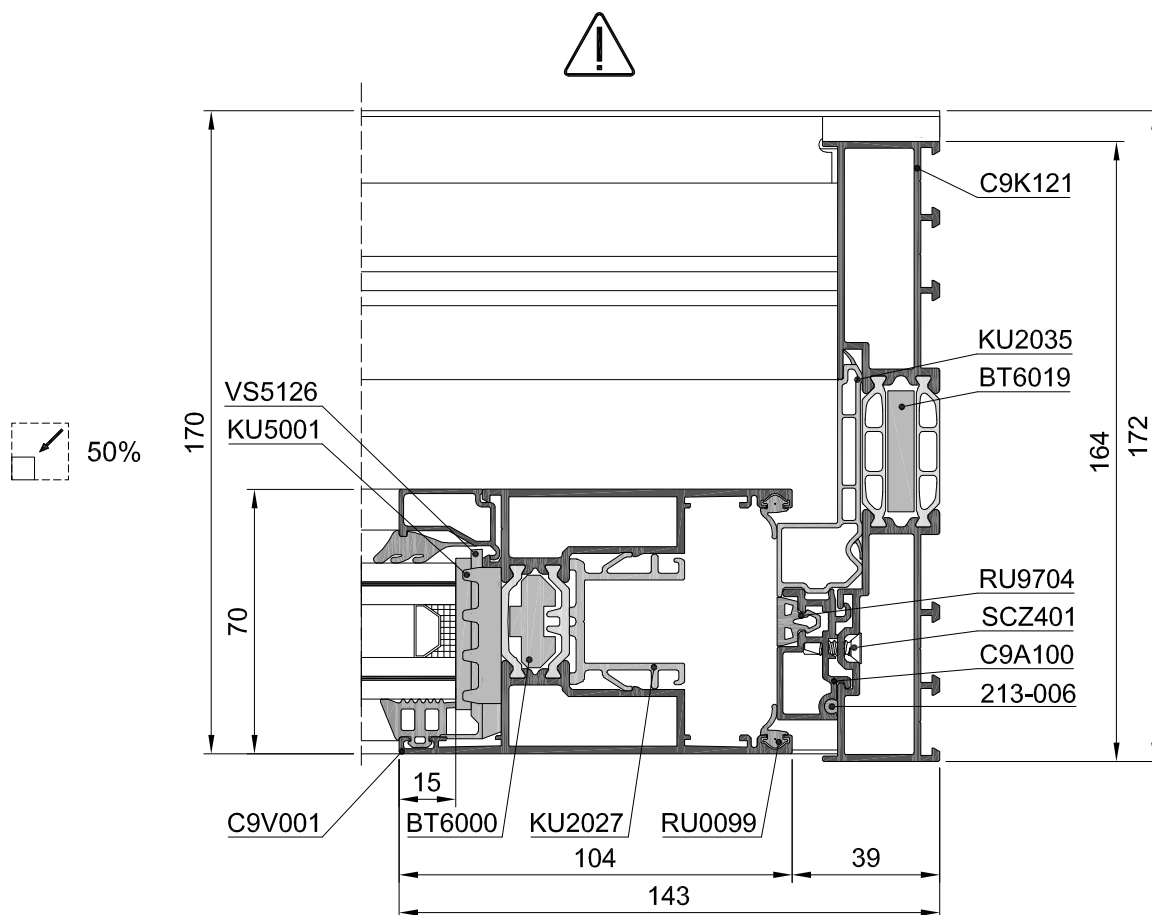
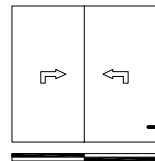

ALZANTE-SCORREVOLE C9V001-C9K120/C9K121 - INFERIORE DESTRO

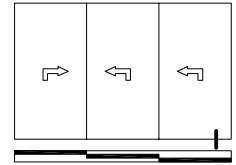

 50%

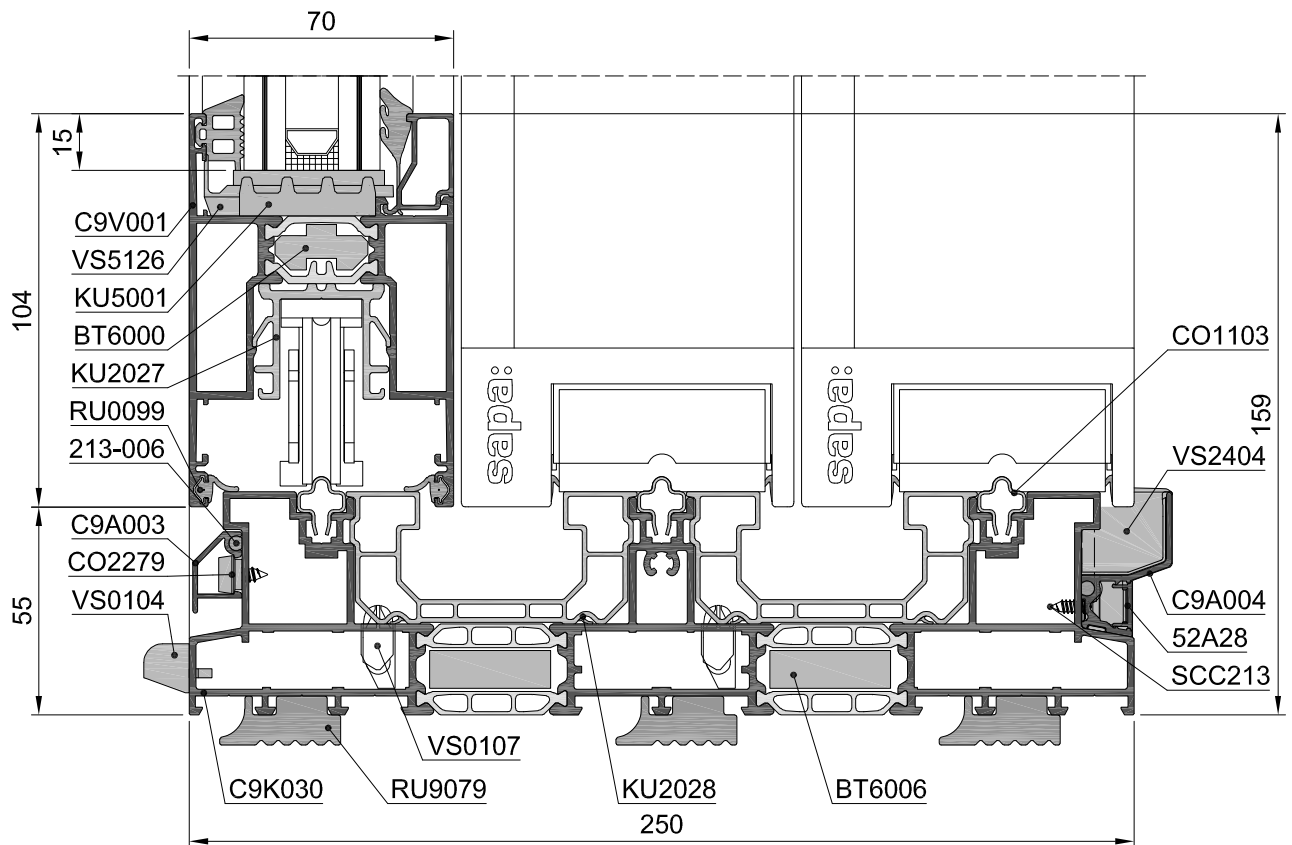

**ALZANTE-SCORREVOLE C9V001-C9K030 - SUPERIORE DESTRO**

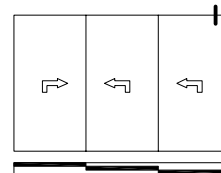

 50%

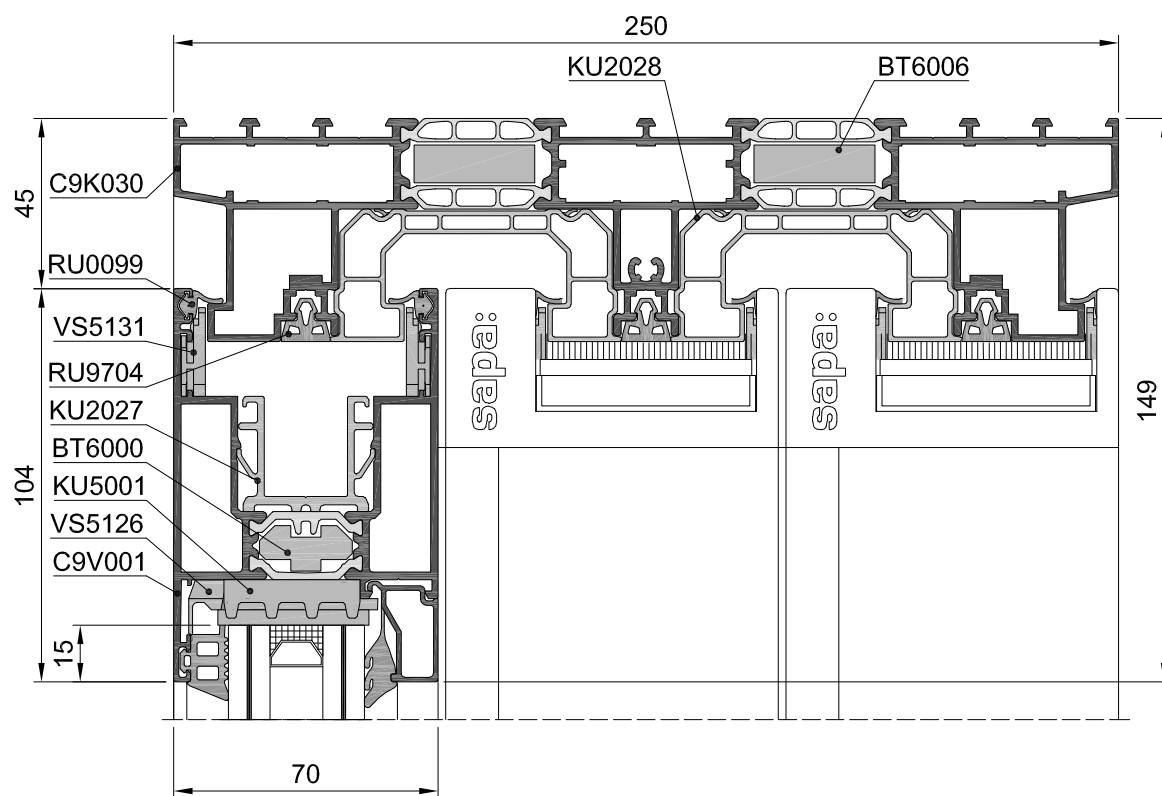

ALZANTE-SCORREVOLE C9V001-C9K030 - SINISTRO

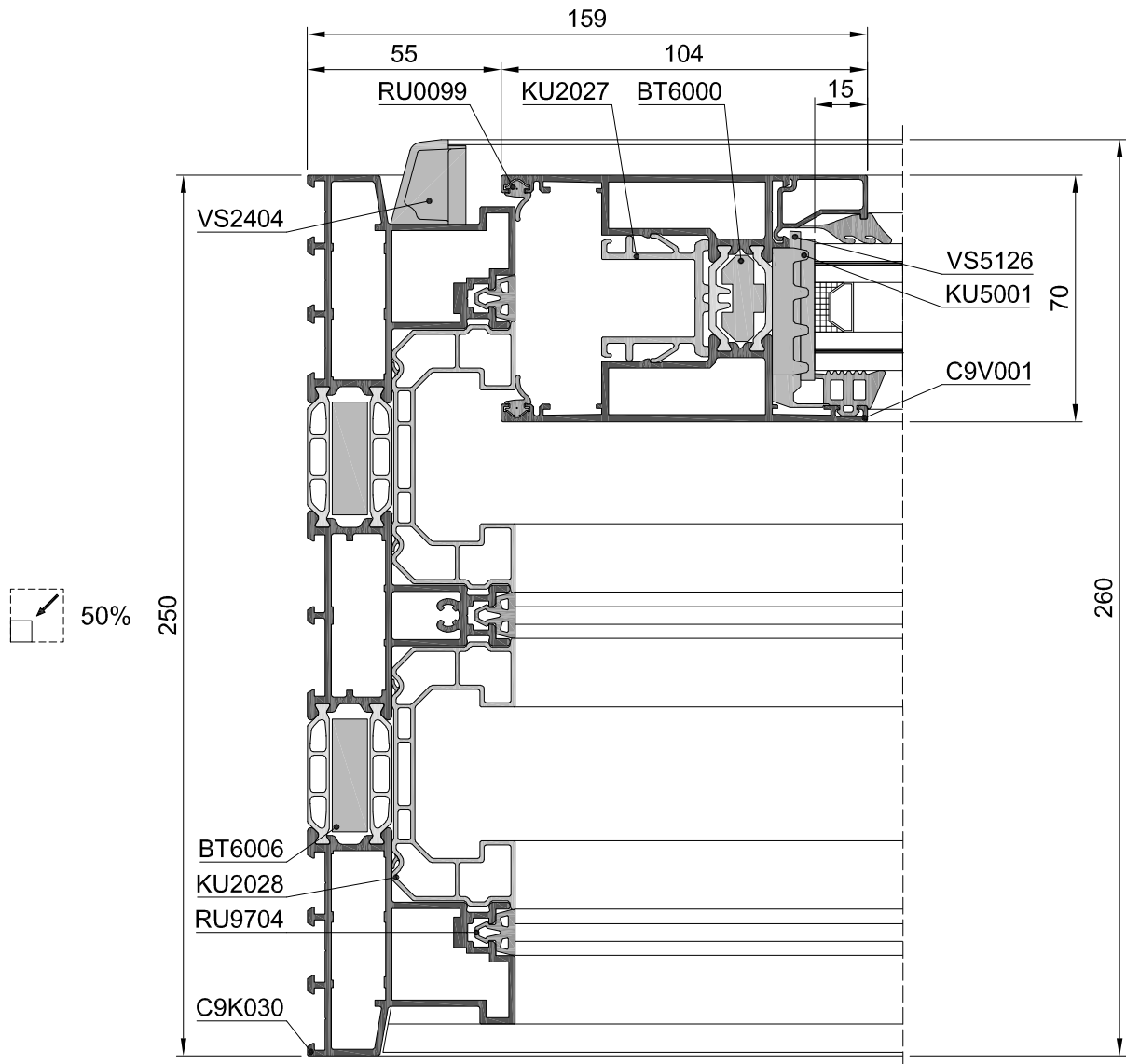
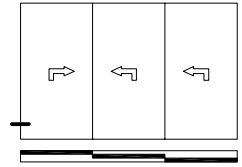

**ALZANTE-SCORREVOLE C9V001-C9K030 - DESTRO**

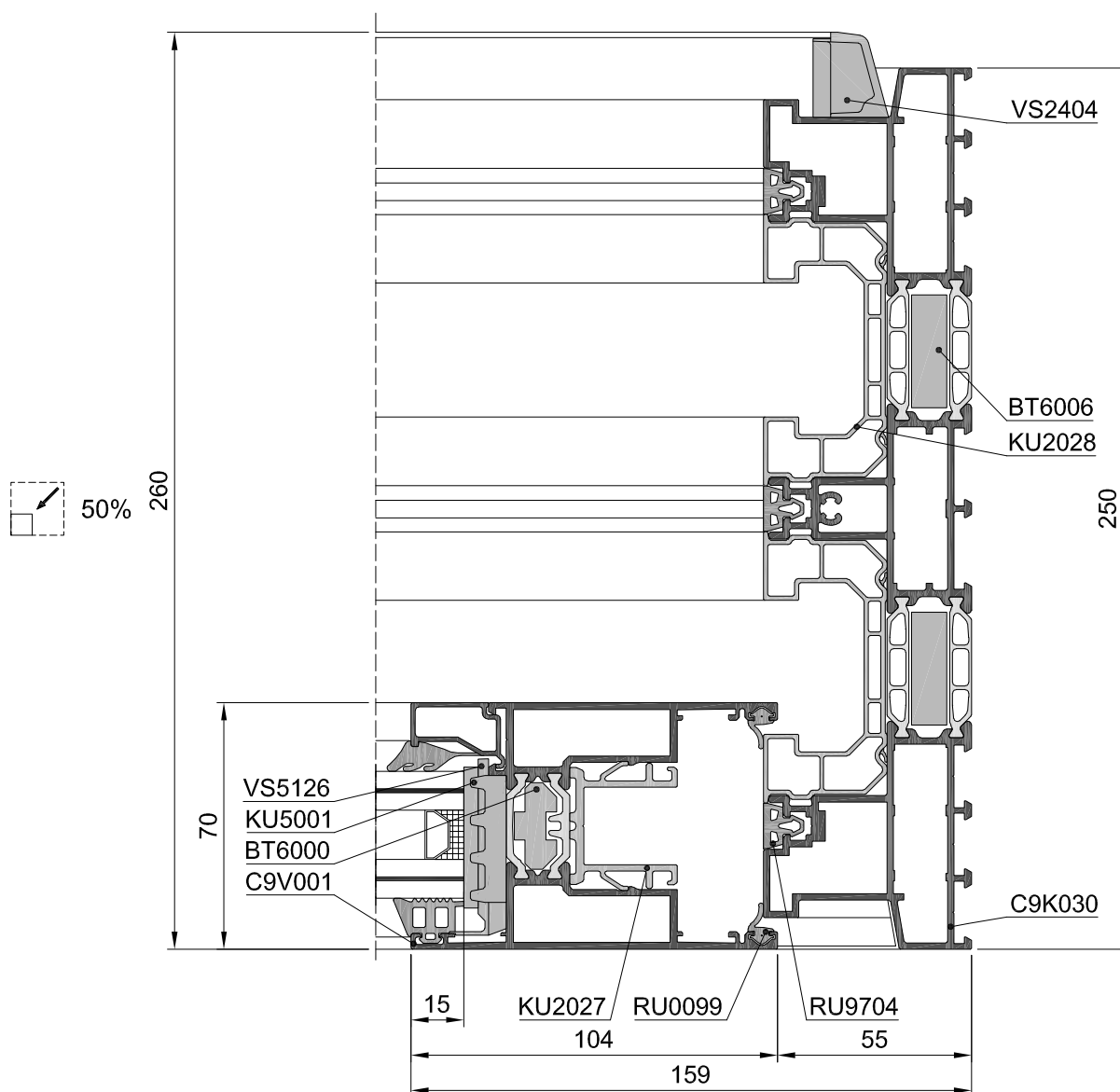
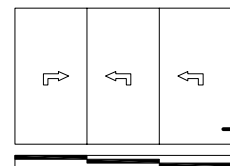



ALZANTE-SCORREVOLE C9V001-C9K030 - CENTRALE

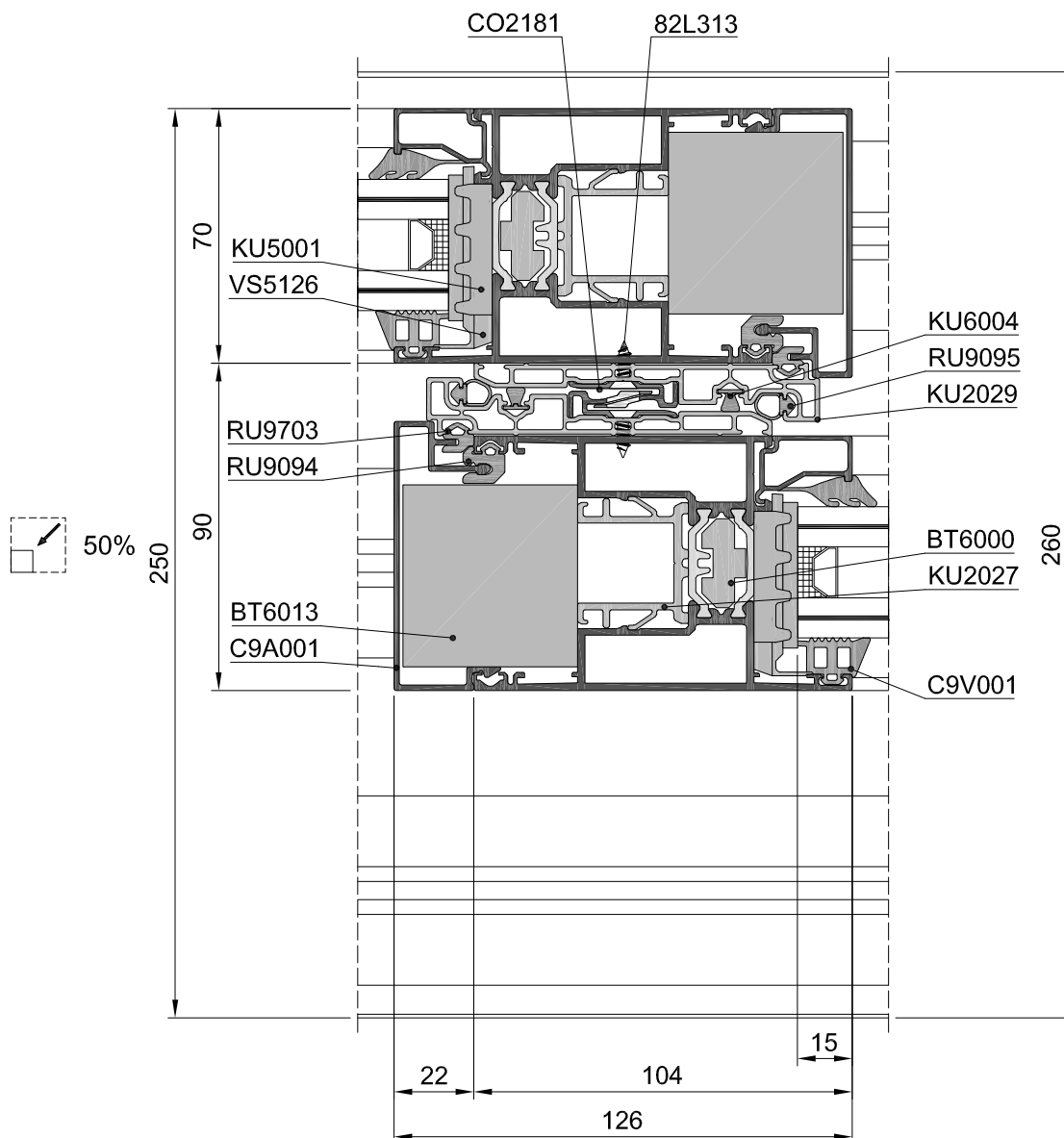
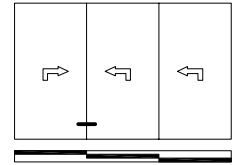

**ALZANTE-SCORREVOLE C9V001-C9K030 - CENTRALE**

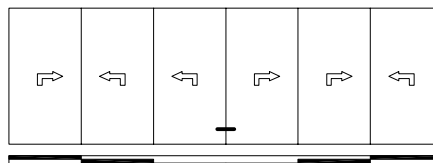

 50%

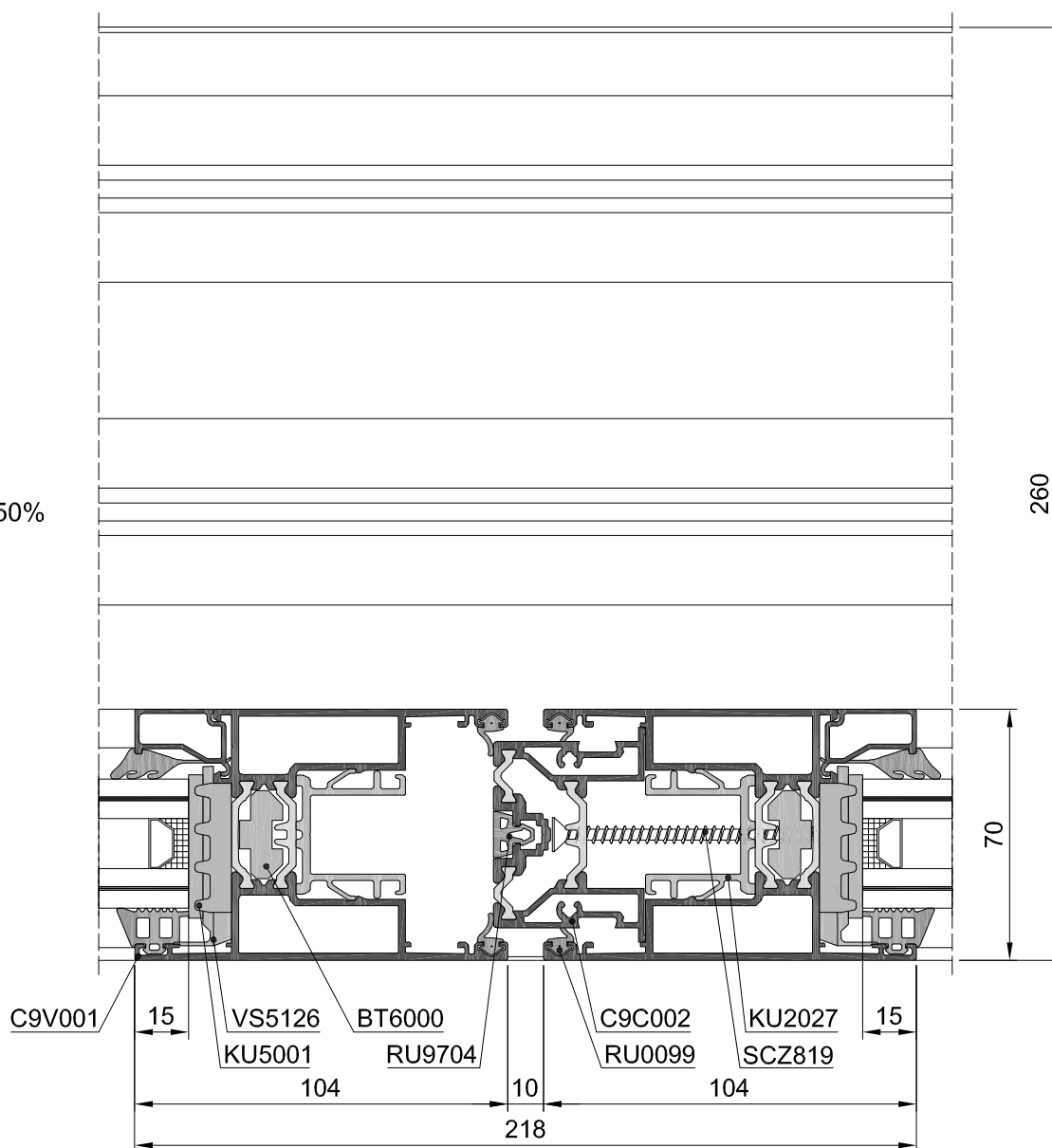

**ALZANTE-SCORREVOLE-ANTA FISSA C9V001-C9K020 - SUPERIORE SINISTRO**

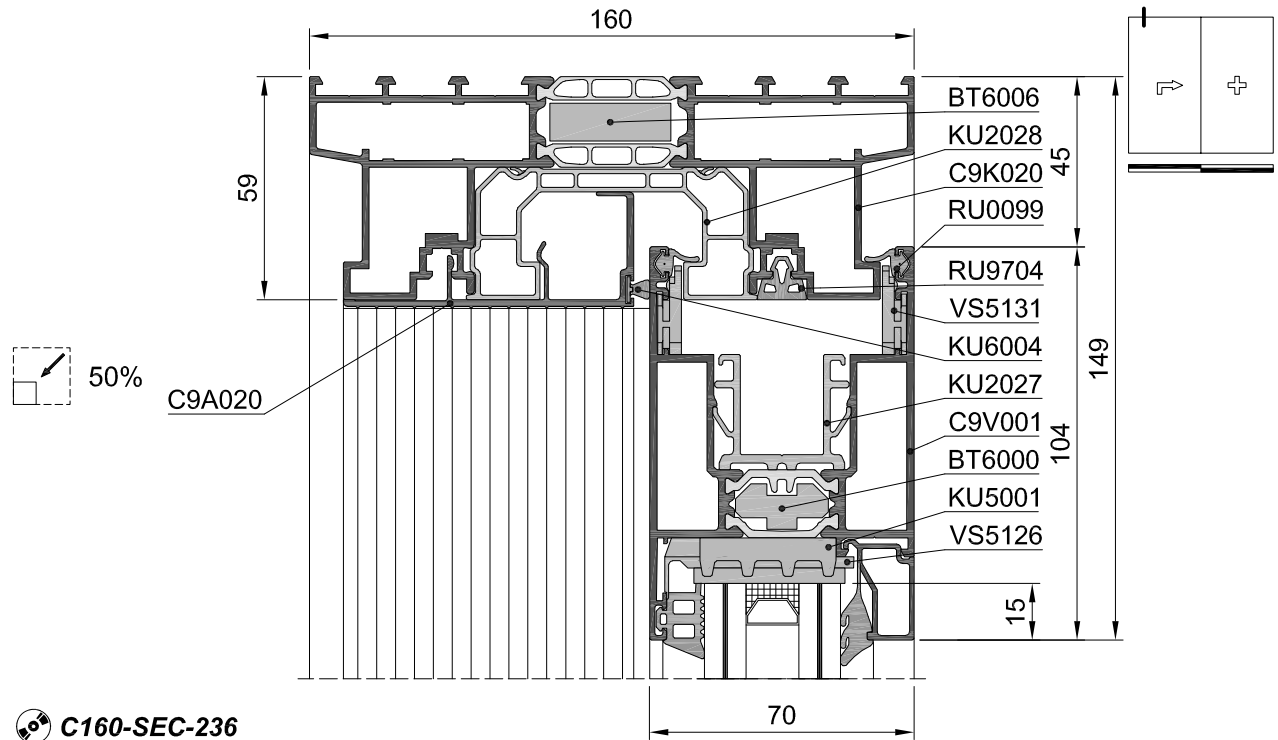

**ALZANTE-SCORREVOLE-ANTA FISSA C9V001-C9K020 - INFERIORE SUPERIORE**

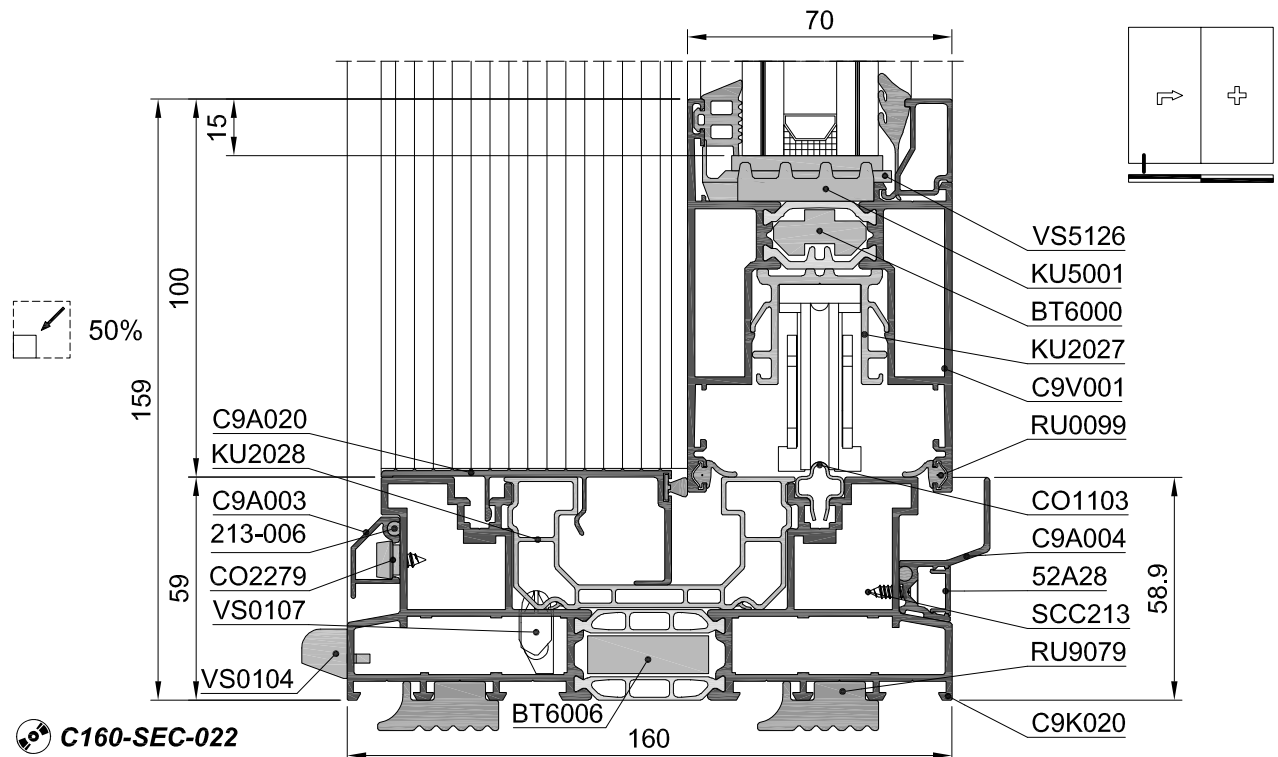

**ALZANTE-SCORREVOLE-ANTA FISSA C9V001-C9K020 - SUPERIORE DESTRO**

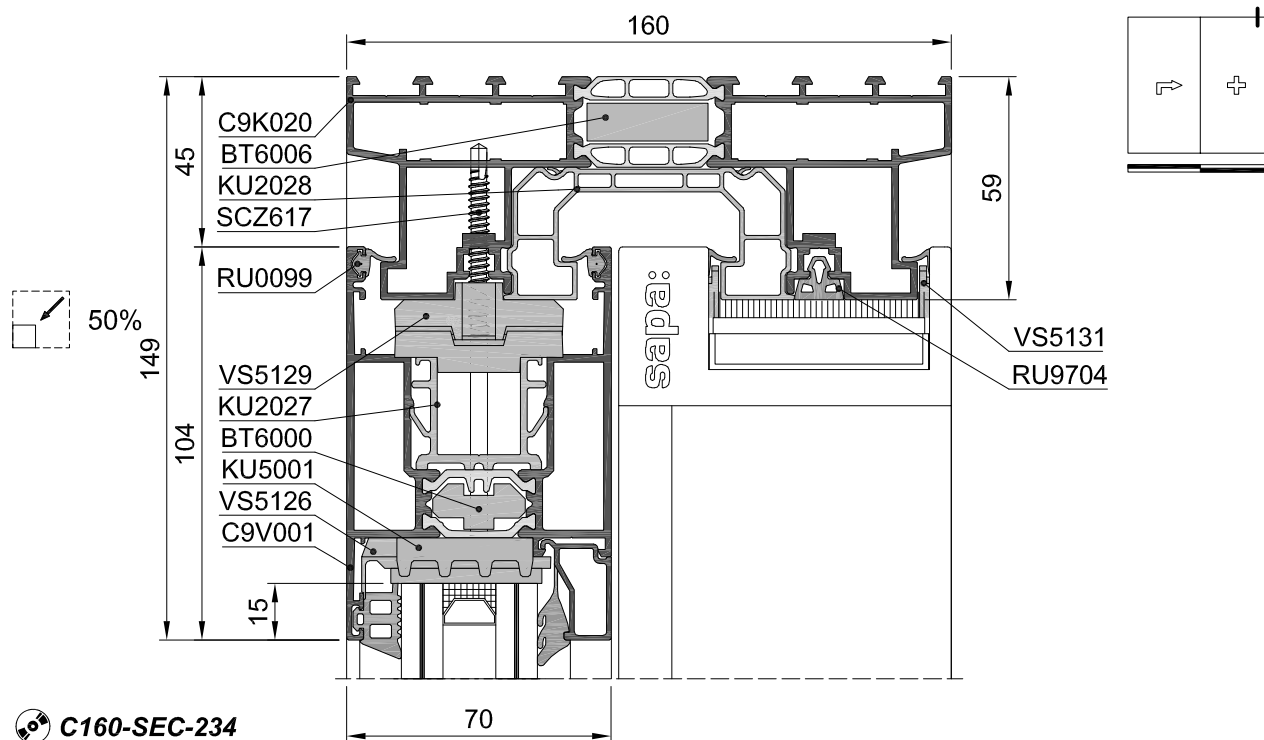

**ALZANTE-SCORREVOLE-ANTA FISSA C9V001-C9K020 - INFERIORE DESTRO**

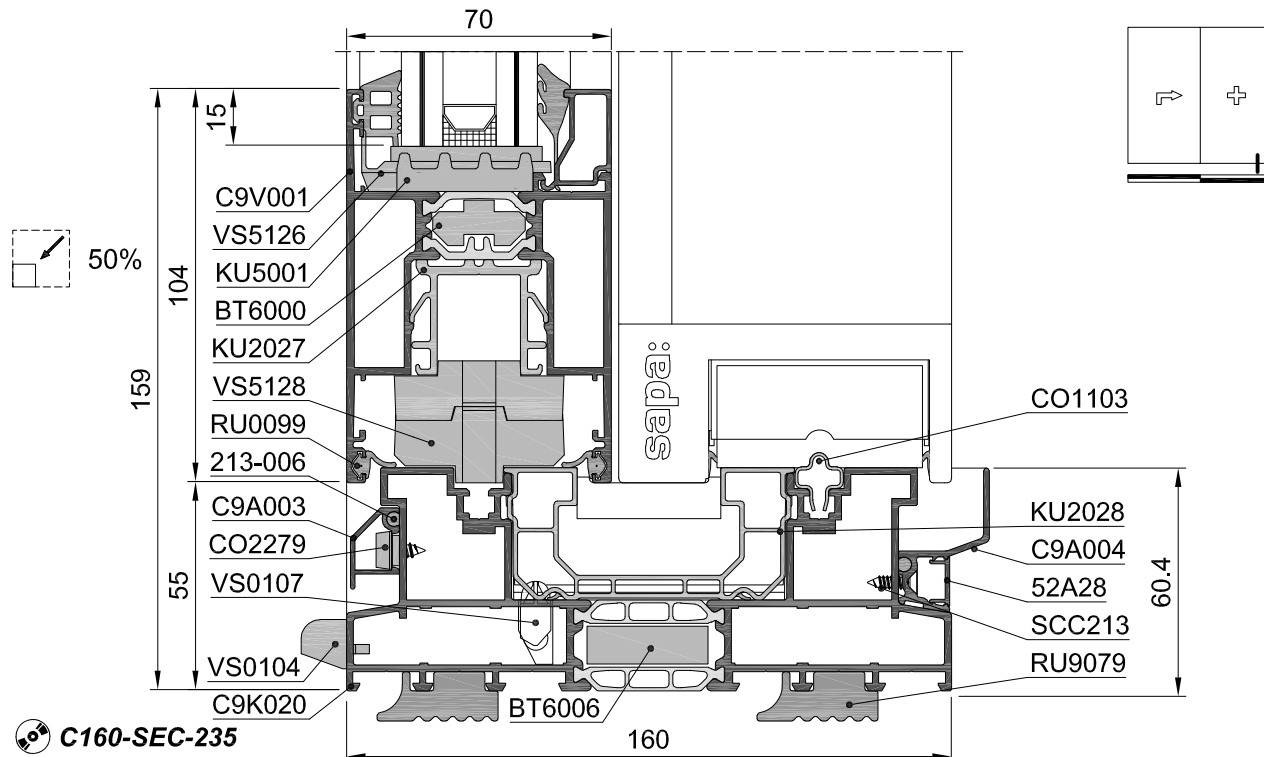

ALZANTE-SCORREVOLE-ANTA FISSA C9V001-C9K020 - SINISTRO

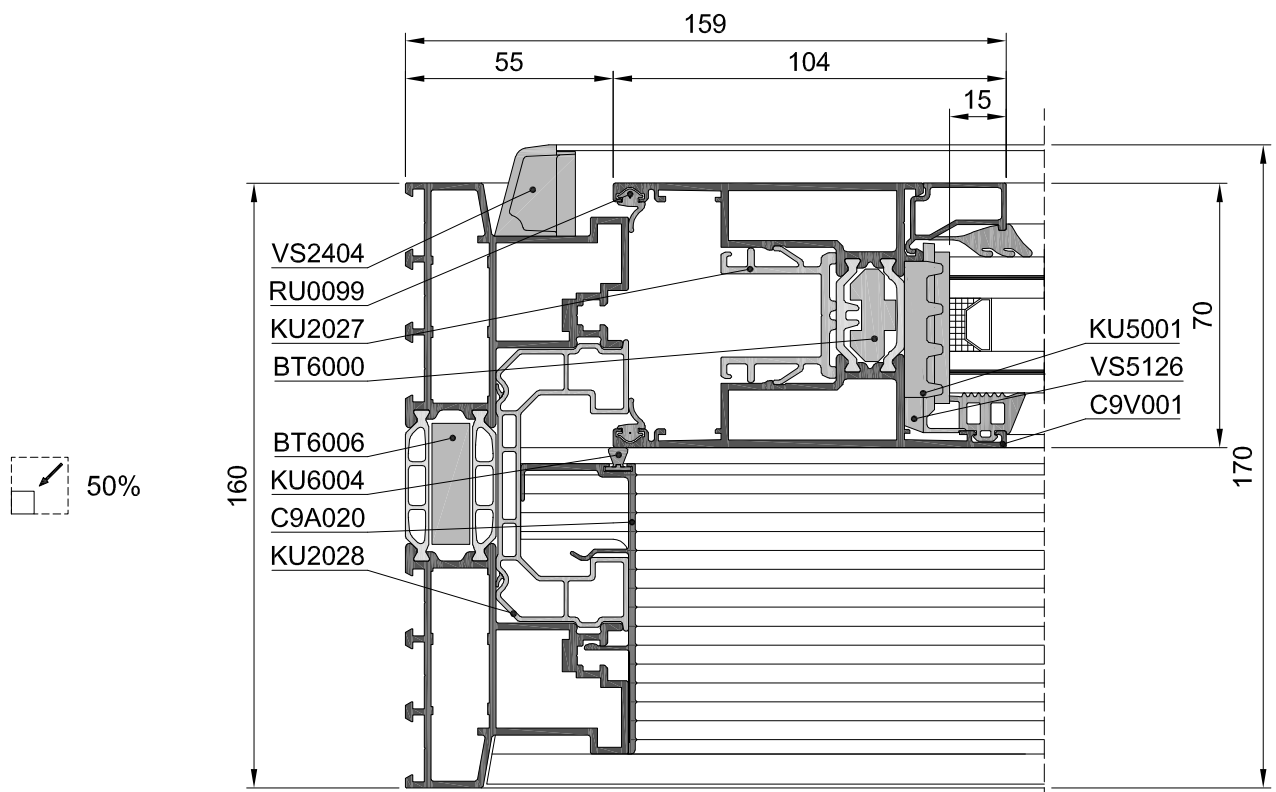
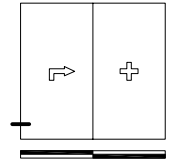

**ALZANTE-SCORREVOLE-ANTA FISSA C9V001-C9K020 - DESTRO**

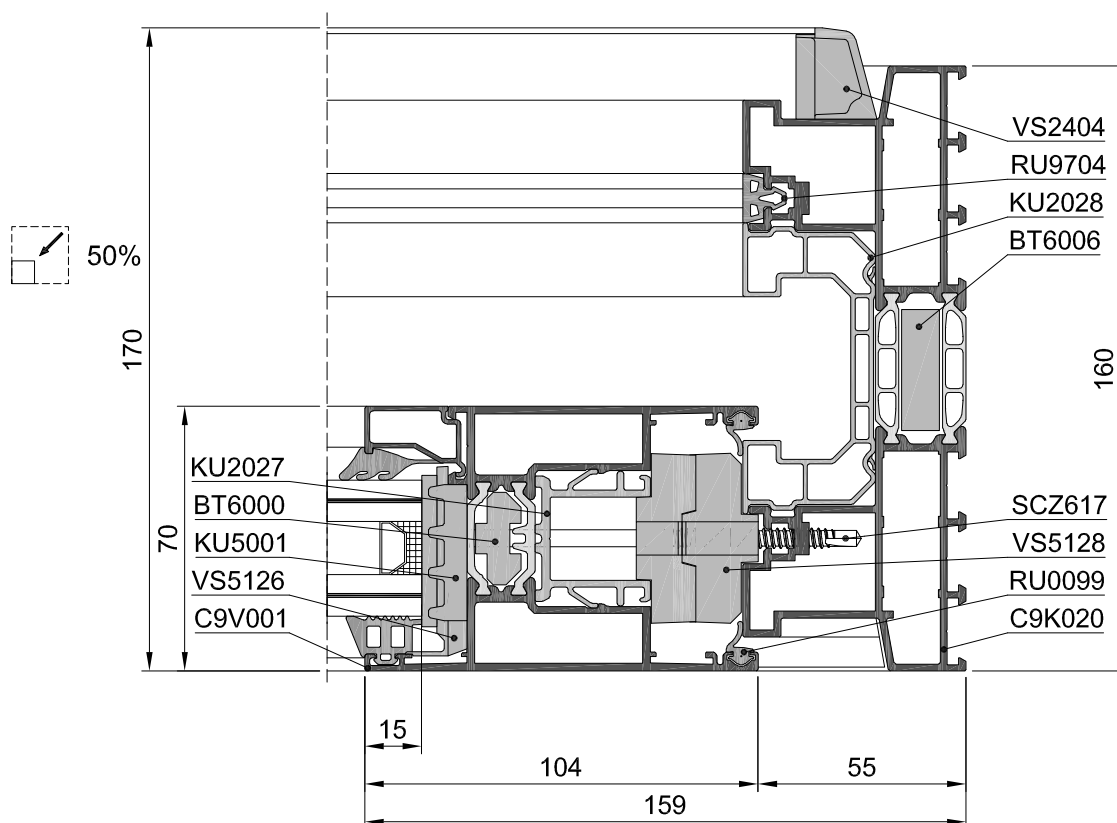
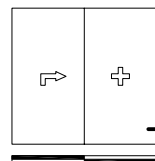

**FISSO-ALZANTE-SCORREVOLE-FISSO C9V001-C9K020 - SUPERIORE**

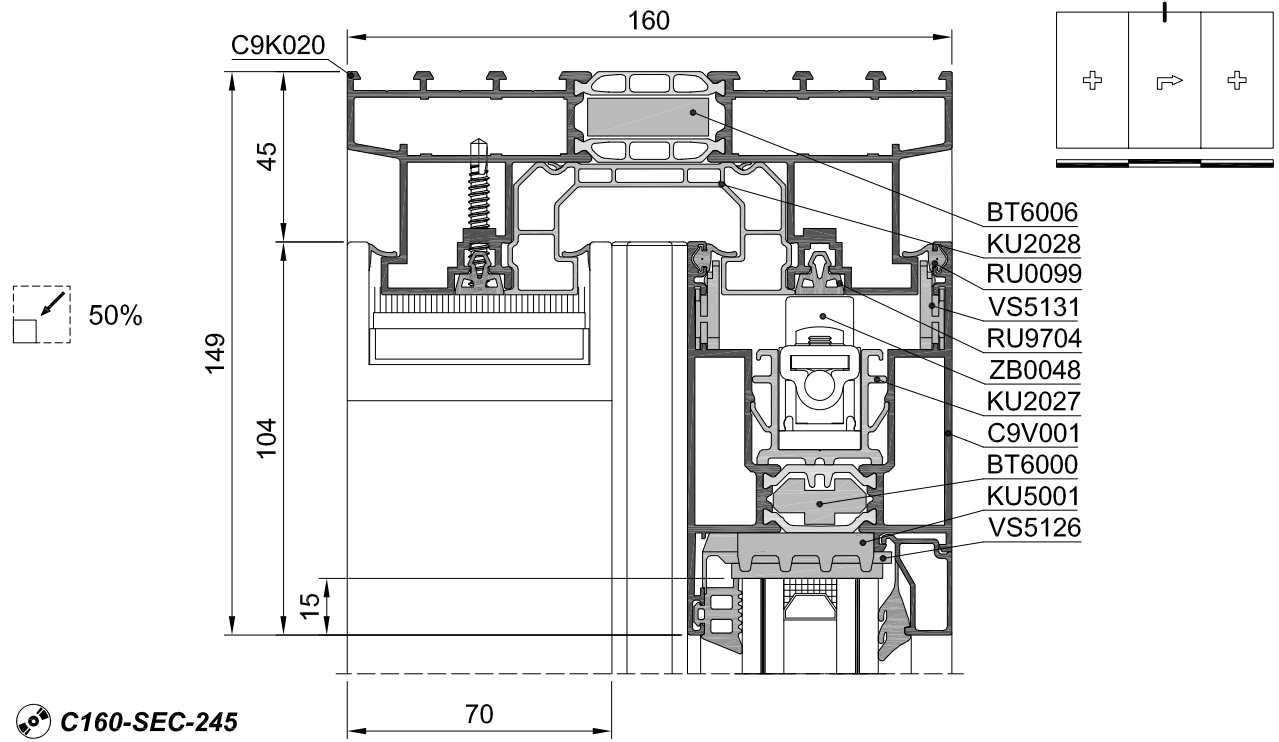

**FISSO-ALZANTE-SCORREVOLE-FISSO C9V001-C9K020 - CENTRALE**

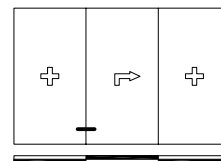

 50%

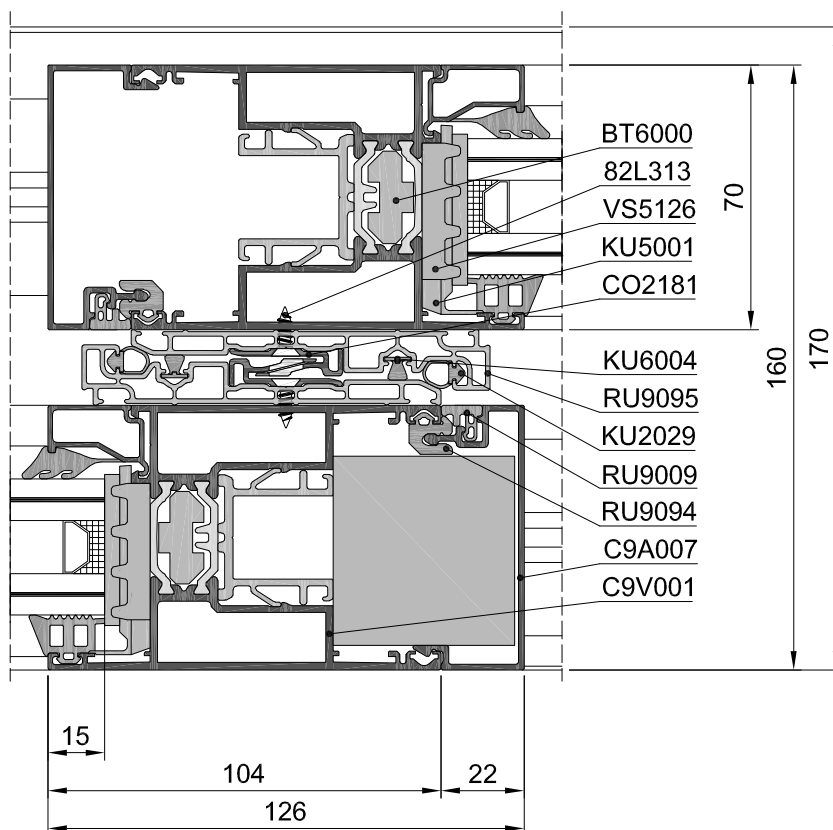



RINFORZO INTERNO - 1 ANTA

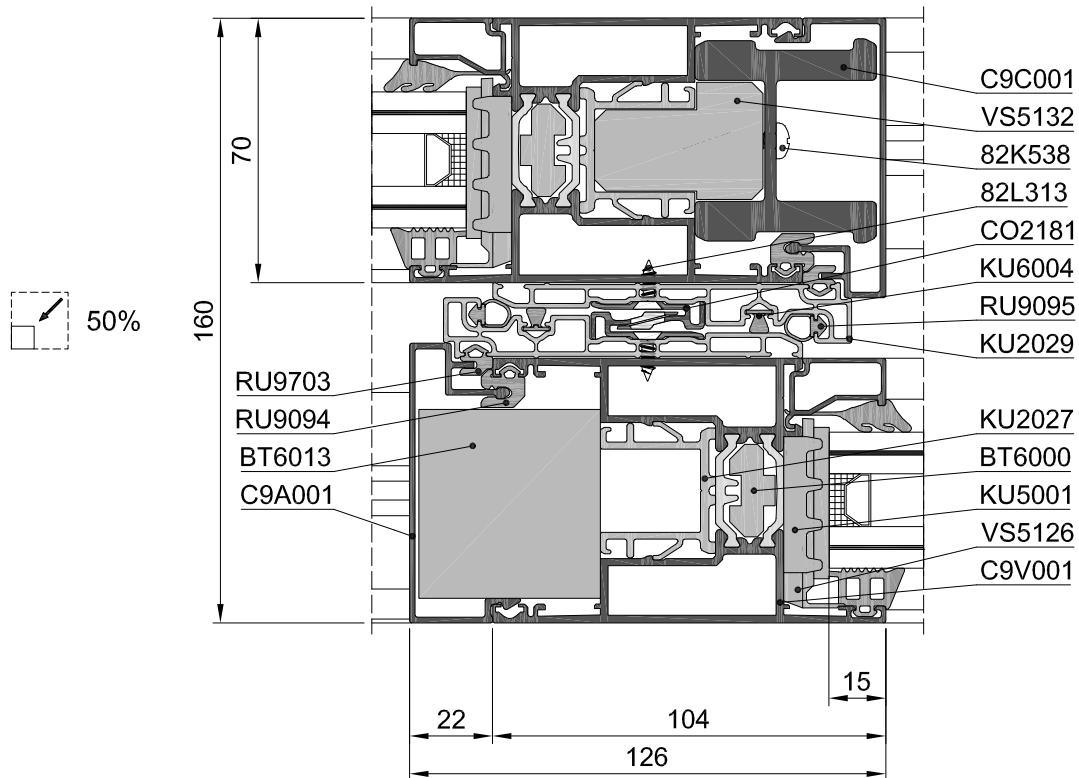
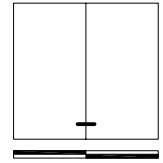

**RINFORZO INTERNO - 2 ANTE**

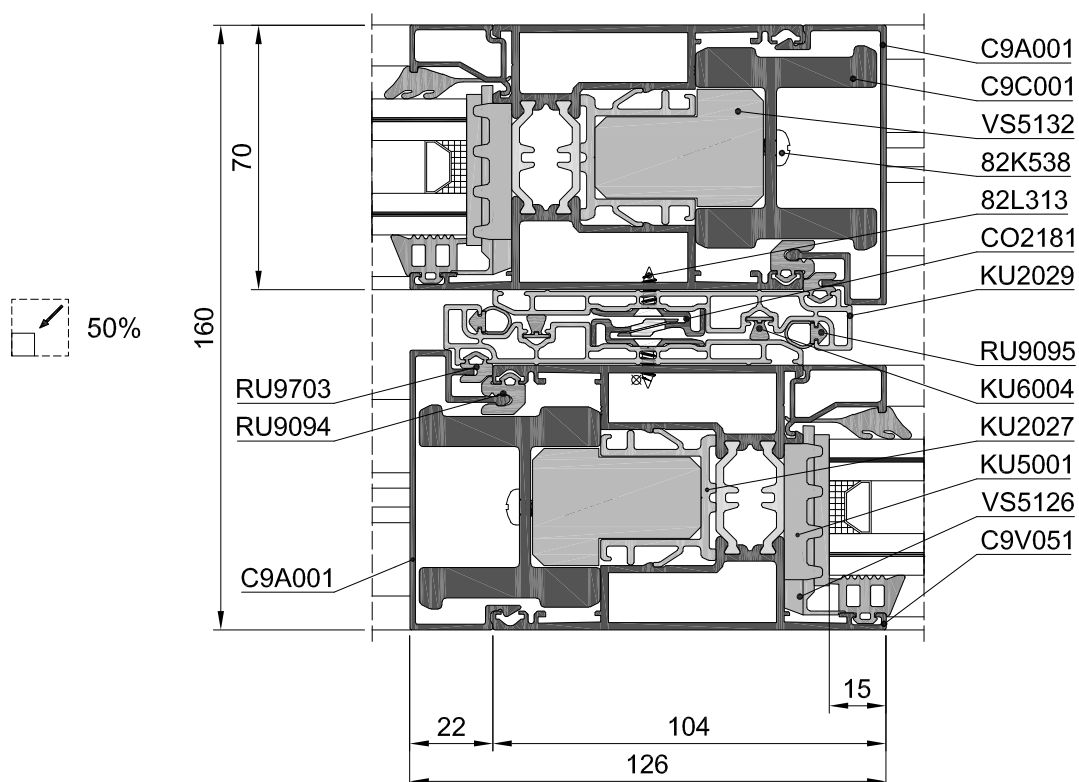
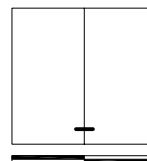

**Distinte di taglio**



1. Le pagine seguenti racchiudono le liste di taglio e la descrizione degli accessori per consentire il calcolo rapido dei materiali. Tuttavia, queste liste mostrano una selezione delle applicazioni più comuni del sistema. Misure di taglio piani di combinazioni di applicazioni o situazioni che non sono in questi elenchi saranno fornite su richiesta.
2. È possibile calcolare le dimensioni delle finestre in maniera semplice o più complessa.
3. Esempio di definizione di "esterno" e "interno" per nodo orizzontale e verticale.

Interno

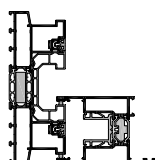

Esterno

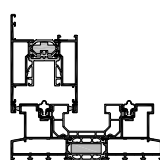

Interno

Esterno



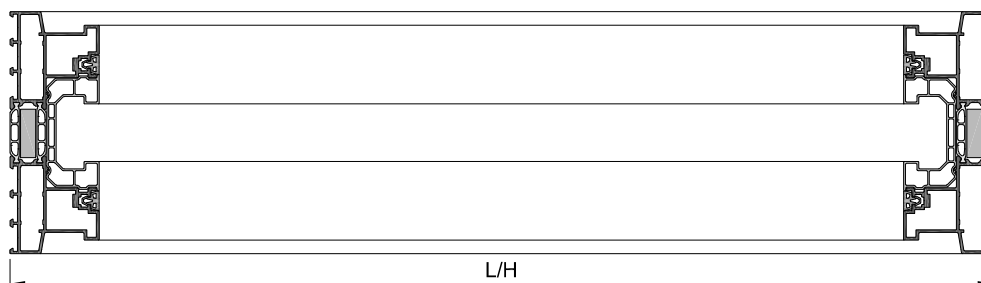



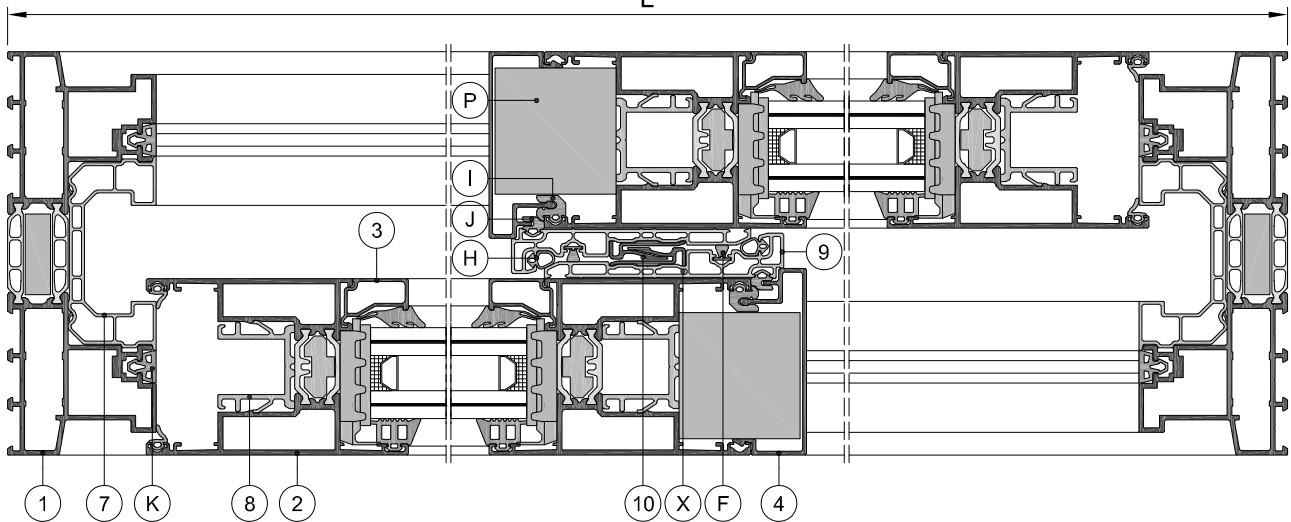
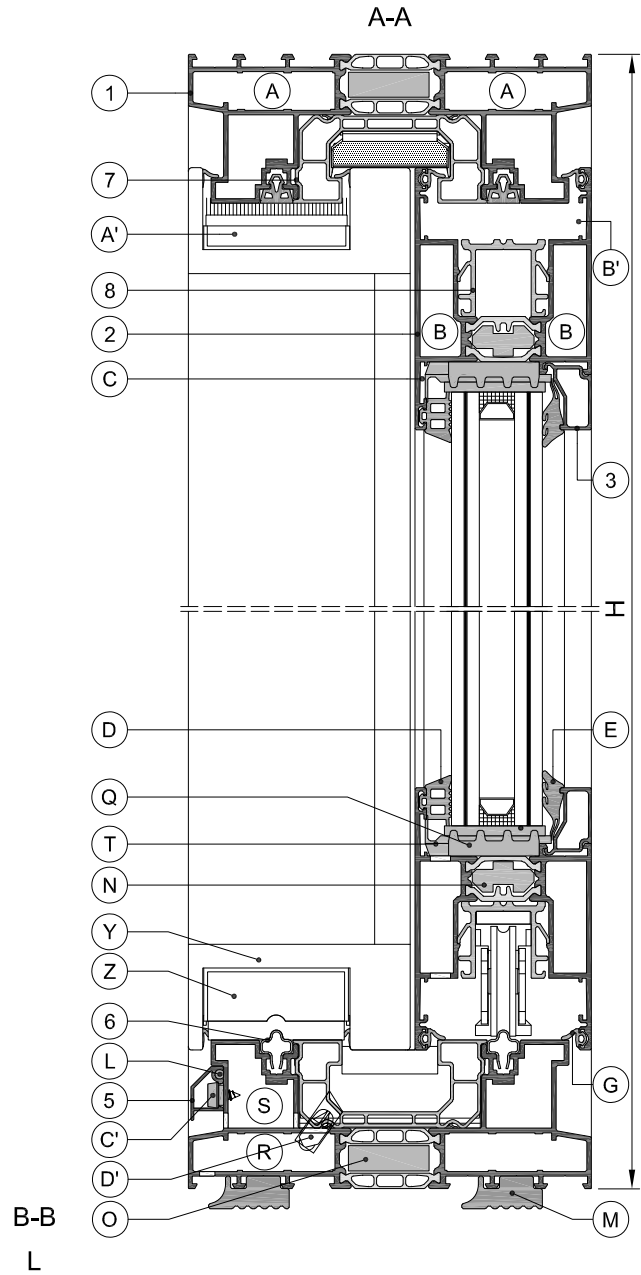
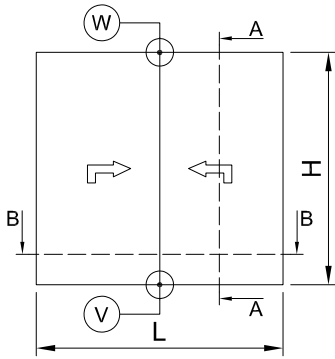













4. Le misure L e H corrispondono alla rispettiva larghezza e altezza del telaio.



5. I parametri consentono di calcolare l'intera gamma di telai, ante e traverse.
6. Si prega di consultare la sezione E per una scelta alternativa di accessori e i capitoli F e J per la ferramenta
7. Fissaggi: per lato almeno due ancoraggi, max. distanza intermedia di 750 mm. Essi sono posti in prossimità di angoli e punti di chiusura punti e sono distanti da angoli e/o traverse alla misura di 200 mm. Essi non sono inclusi nelle distinte consultabili anche nel capitolo J assemblaggio.
8. Vetratura: per informazioni sull'installazione supporti vetri e piani di appoggio, vedere il capitolo J assemblaggio. I fermavetri hanno un'altezza uniforme di 22 mm. (vedi capitolo D vetri).



## 2-BINARI 2-ANTE ALZANTE SCORREVOLE TELAIO 45°

N°	PROFILATI		QUANTITA'	TAGLIO	LUNGHEZZA TAGLIO	
	Icona	Modello			L	H
1		C9K020	2 2		L	H
2		C9V001	4 4		L/2 - 14	H - 100
3		GCxxxx	4 4		L/2 - 178	H - 308
4		C9A001	2		H - 184	
5		C9A003	1		L - 44	
6		CO1103	2		L - 118	
7		KU2028	2 2		L - 48	H - 48
8		KU2027	4 4		L/2 - 71	H - 157
9		KU2029	2		H - 104	
10		CO2181	2		H - 104	
<b>DIMENSIONE VETRI</b>					L/2 - 192	H - 278

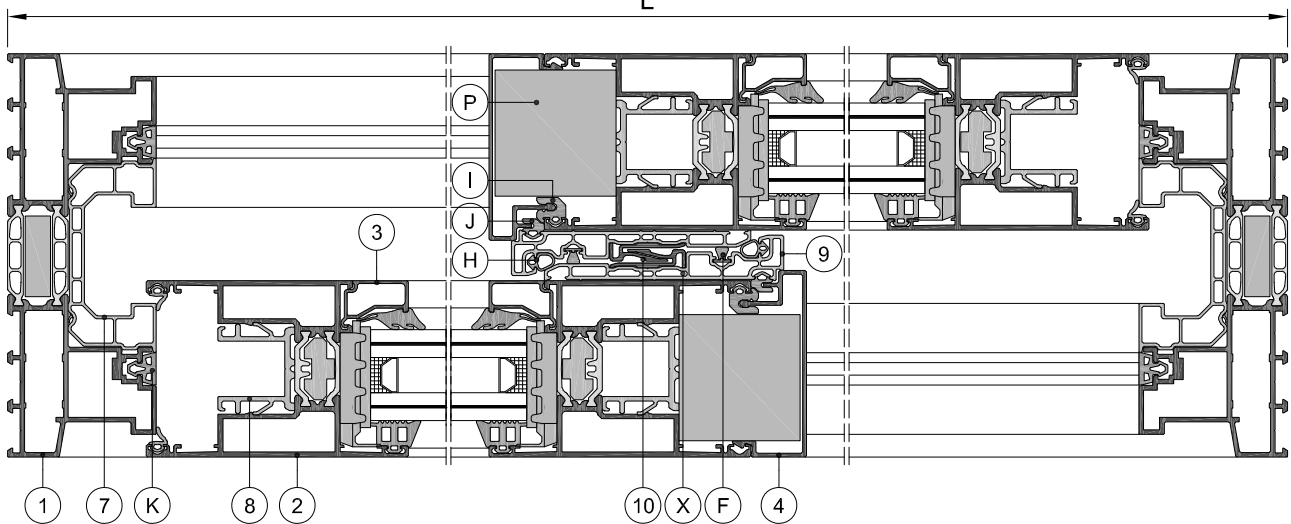
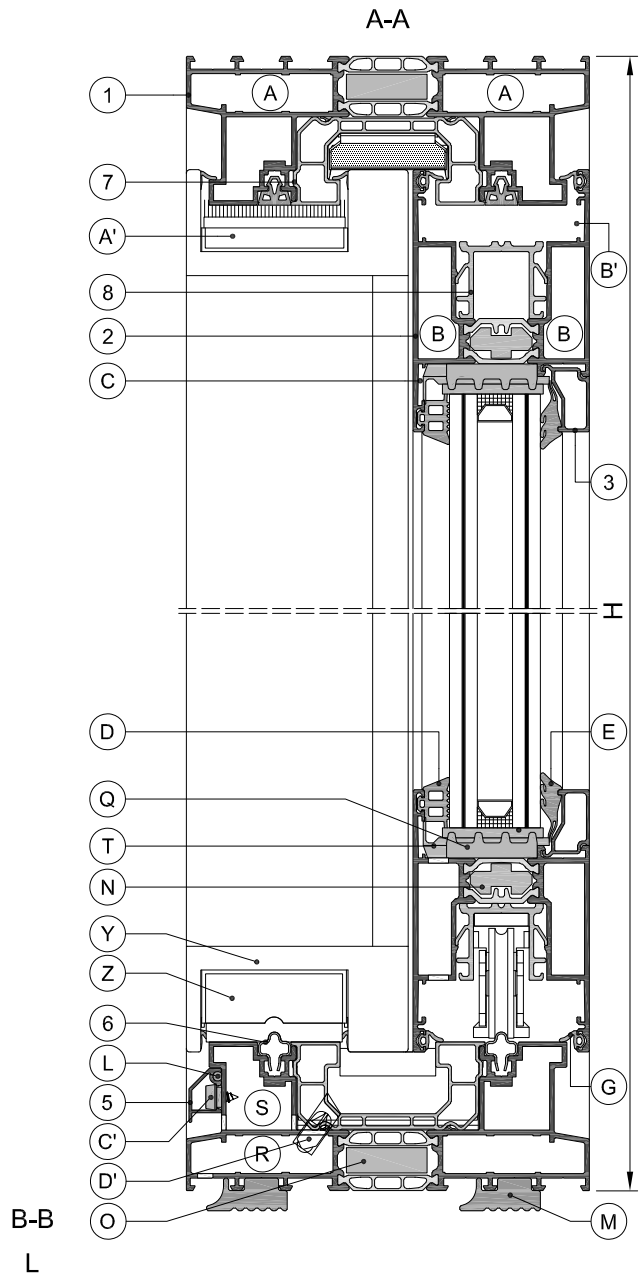
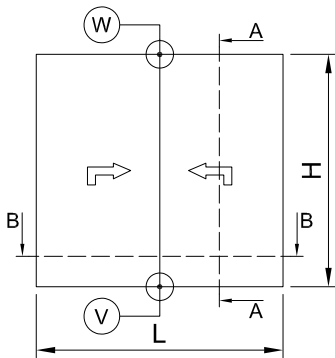









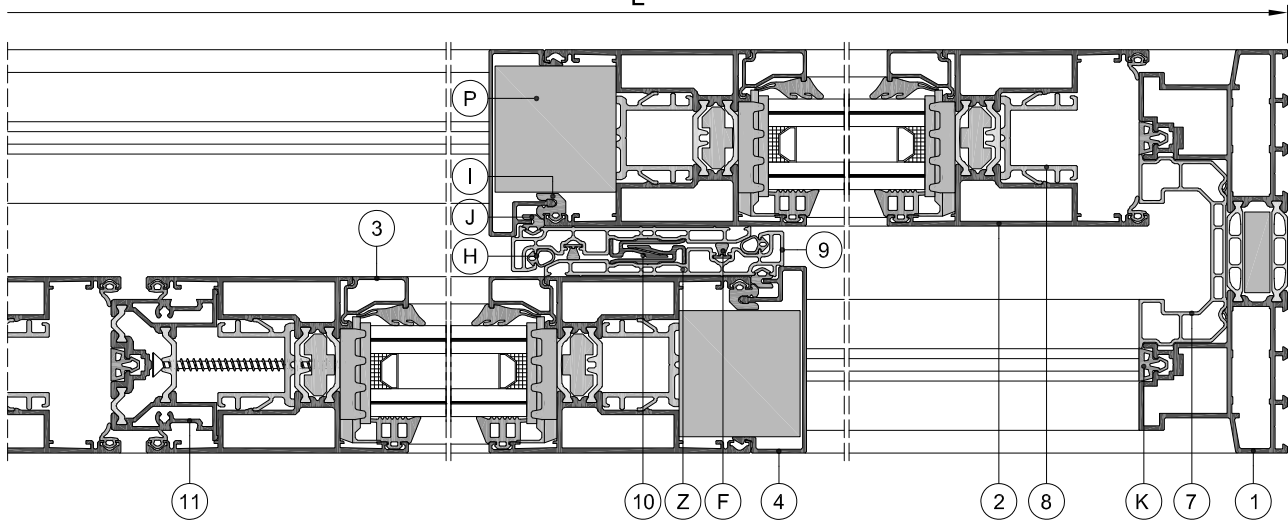
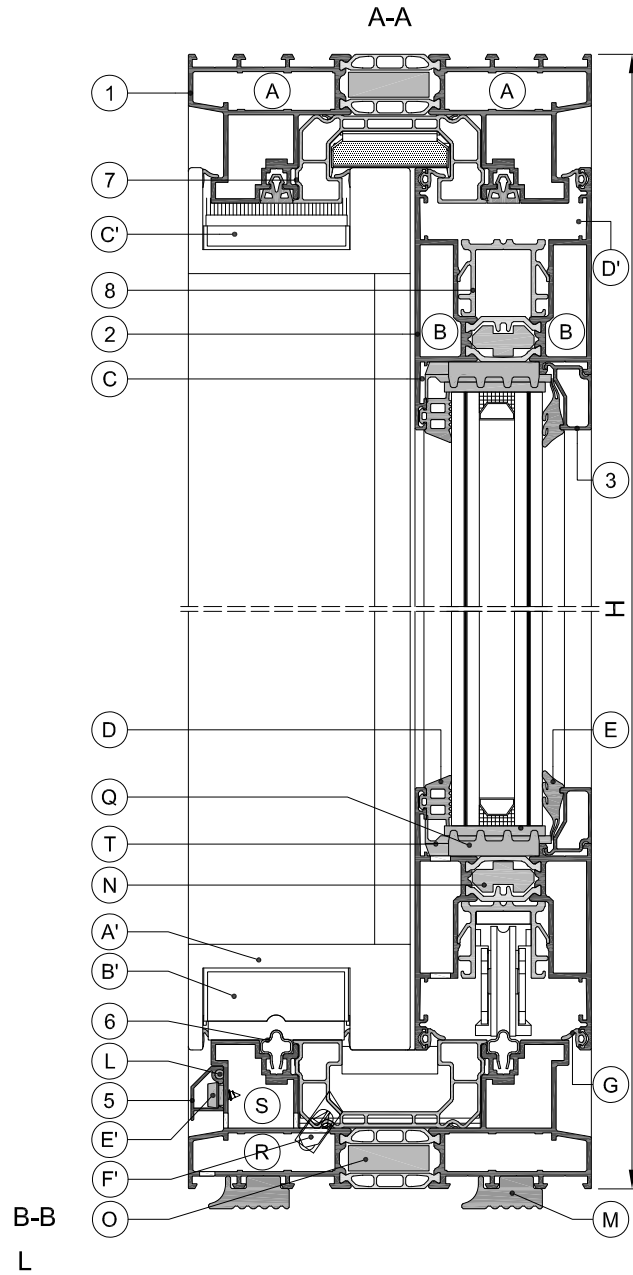
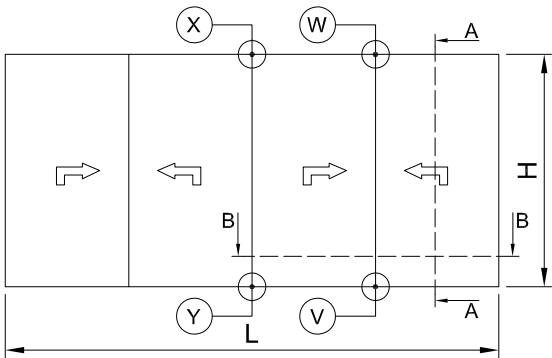

















## 2-BINARI 2-ANTE ALZANTE SCORREVOLE TELAIO 45°

	ACCESSORI	QUANTITA'
<b>A</b>	HV0G03 / 778500	8 / 32
<b>B</b>	HV3H26 / 778500 / 71C011	16 / 32 / 32
<b>C</b>	HV4K00 / HV4K01	16 / 8
<b>D</b>	RU0002	2L + 4H
<b>E</b>	39R507	2L + 4H
<b>F</b>	KU6004	2H
<b>G</b>	RU0099	4L + 4H
<b>H</b>	RU9095	2H
<b>I</b>	RU9094	2H
<b>J</b>	RU9703	2H
<b>K</b>	RU9704	2L + 4H
<b>L</b>	213-006	L
<b>M</b>	RU9079 - FACOLTATIVA	2L
<b>N</b>	BT6000-VERSIONE SI	2L + 4H
<b>O</b>	BT6006-VERSIONE SI	2L + 2H

	ACCESSORI	QUANTITA'
<b>P</b>	BT6013-VERSIONE SI	2H
<b>Q</b>	KU5001-VERSIONE SHI	2L + 4H
<b>R</b>	VS9951	2
<b>S</b>	VS9950	4
<b>T</b>	VS5130	16
<b>V</b>	CO1105	1
<b>W</b>	CO1111	1
<b>X</b>	VS9148 (set)	2
<b>Y</b>	VS9149 (set)	2
<b>Z</b>	CO1107	2
<b>A'</b>	CO1110	2
<b>B'</b>	VS5131	8
<b>C'</b>	CO2279	3/m
<b>D'</b>	VS0107	1
	D4074009	VEDI PAG. J.1.4
	SV9002	1



## 2-BINARI 4-ANTE ALZANTE SCORREVOLE TELAIO 45°

	PROFILATI		QUANTITA'	TAGLIO	LUNGHEZZA TAGLIO	
		CODE			L	H
1		C9K020	2 2		L	H
2		C9V001	8 8		L/4 + 11	H - 100
3		GCxxxx	8 8		L/4 - 153	H - 308
4		C9A001	4		H - 184	
5		C9A003	1		L - 44	
6		CO1103	2		L - 118	
7		KU2028	2 2		L - 48	H - 48
8		KU2027	8 8		L/4 - 46	H - 157
9		KU2029	4		H - 104	
10		CO2181	4		H - 104	
11		C9C002	1		H - 179	
<b>DIMENSIONE VETRI</b>					L/4 - 167	H - 278

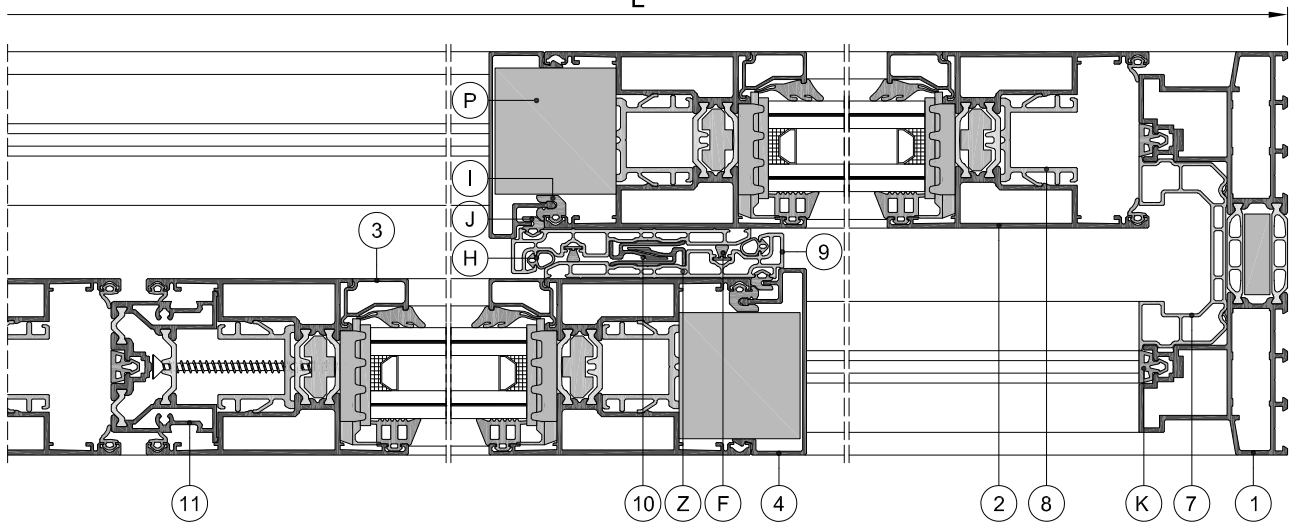
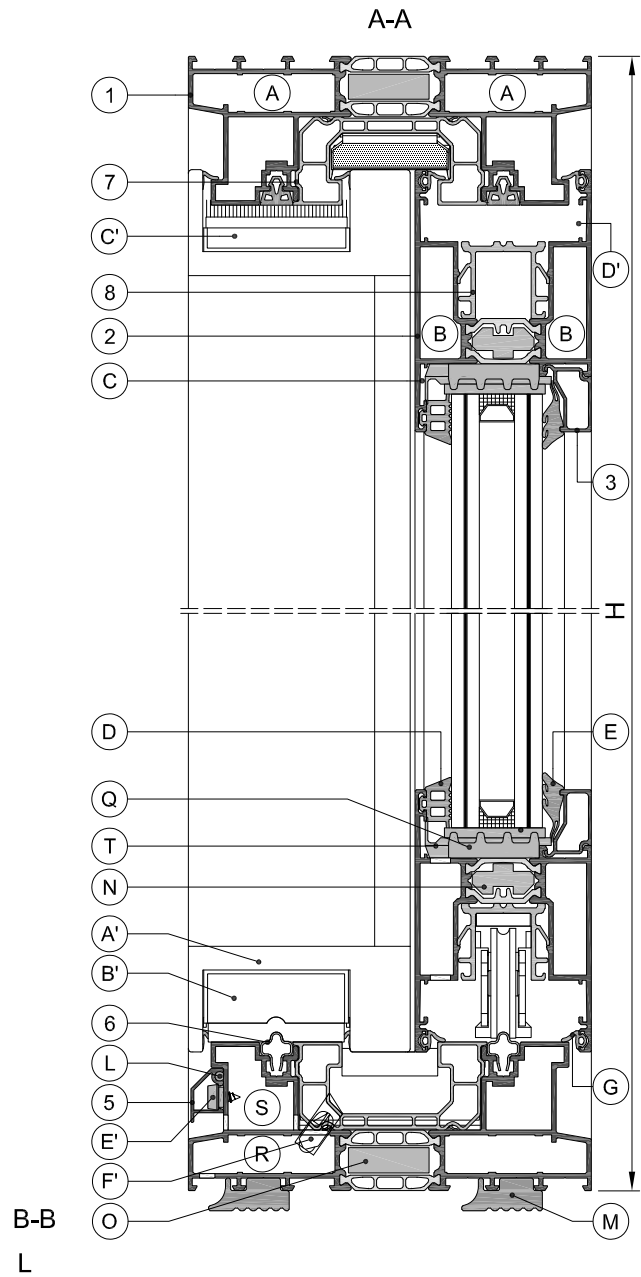
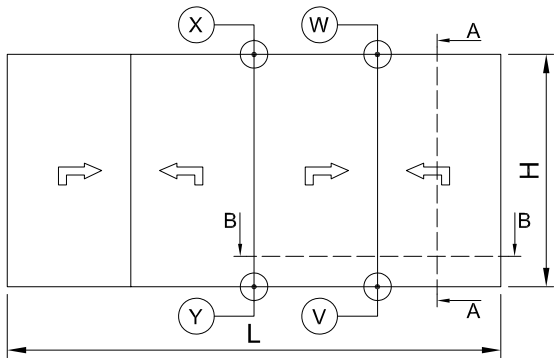







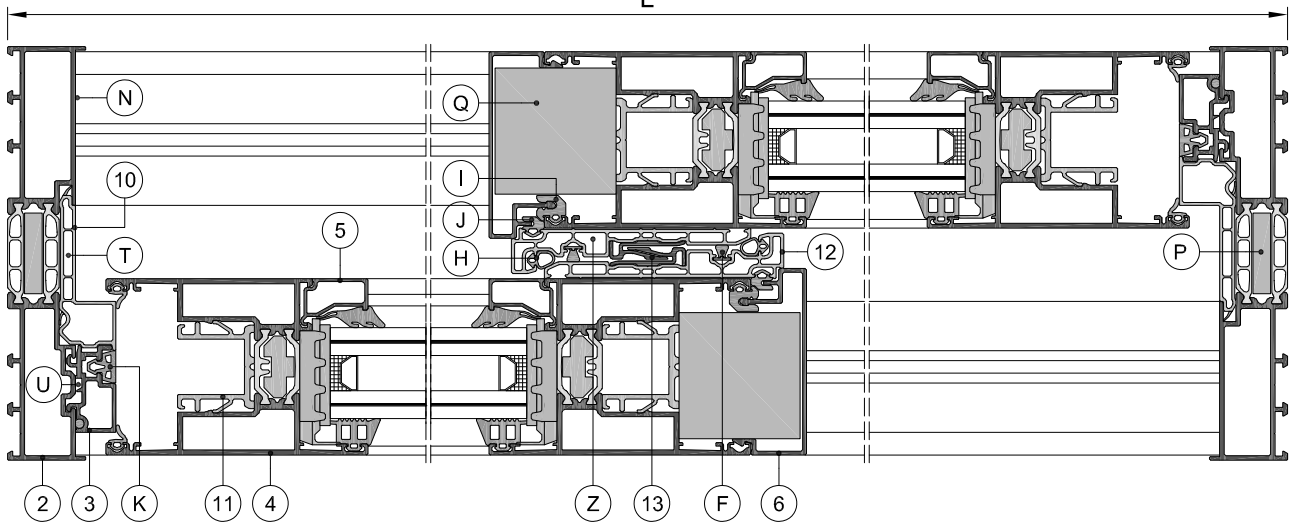
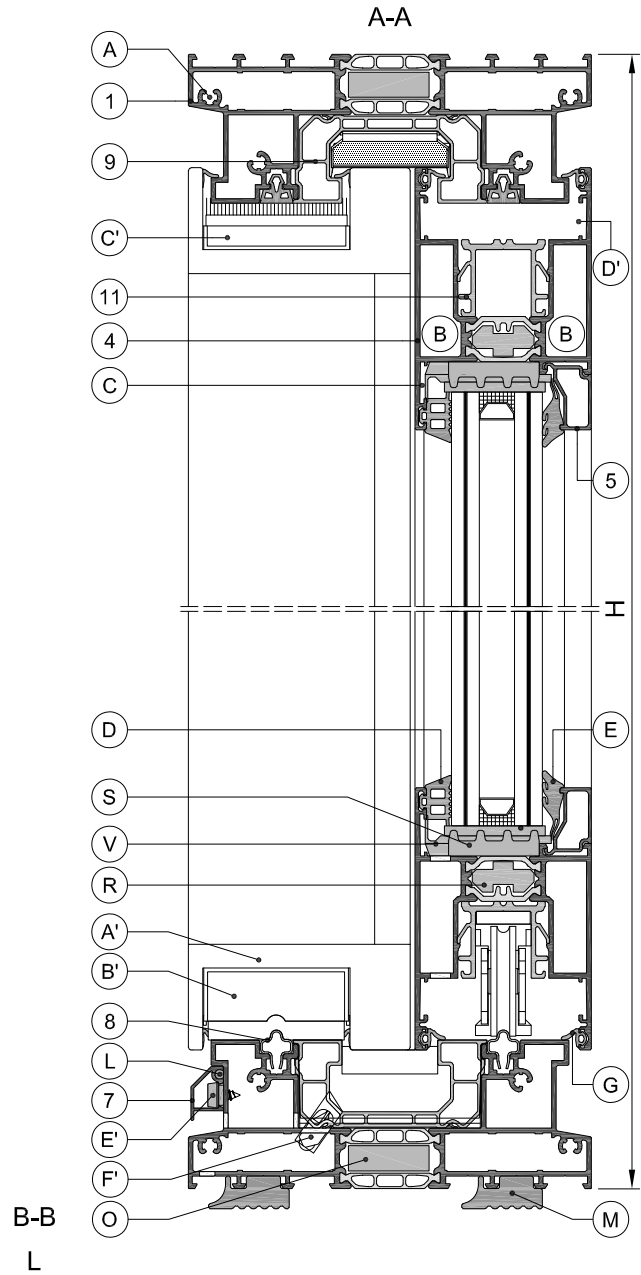
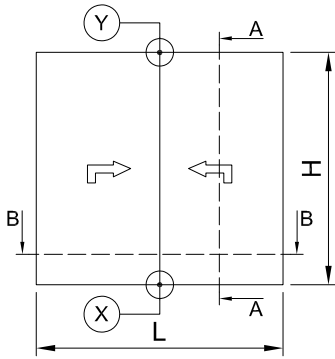



















## 2-BINARI 4-ANTE ALZANTE SCORREVOLE TELAIO 45°

	ACCESSORI	QUANTITA'
<b>A</b>	HV0G03 / 778500	8 / 32
<b>B</b>	HV3H26 / 778500 / 71C011	32 / 64 / 64
<b>C</b>	HV4K00 / HV4K01	32 / 16
<b>D</b>	RU0002	2L + 8H
<b>E</b>	39R507	2L + 8H
<b>F</b>	KU6004	4H
<b>G</b>	RU0099	4L + 8H
<b>H</b>	RU9095	4H
<b>I</b>	RU9094	4H
<b>J</b>	RU9703	4H
<b>K</b>	RU9704	2L + 5H
<b>L</b>	213-006	L
<b>M</b>	RU9079 - FACOLTATIVA	2L
<b>N</b>	BT6000-VERSIONE SI	2L + 8H
<b>O</b>	BT6006-VERSIONE SI	2L + 2H
<b>P</b>	BT6013-VERSIONE SI	4H

	ACCESSORI	QUANTITA'
<b>Q</b>	KU5001-VERSIONE SHI	2L + 8H
<b>R</b>	VS9950	4
<b>S</b>	VS9951	2
<b>T</b>	VS5130	32
<b>V</b>	CO1105	2
<b>W</b>	CO1111	2
<b>X</b>	CO1118	1
<b>Y</b>	CO1125	1
<b>Z</b>	VS9148 (set)	4
<b>A'</b>	VS9149 (set)	4
<b>B'</b>	CO1107	4
<b>C'</b>	CO1110	4
<b>D'</b>	VS5131	16
<b>E'</b>	CO2279	3/m
<b>F'</b>	VS0107	2
	D4074009	VEDI PAG. J.1.4
	CO1214	2
	SV9002	2



## 2-BINARI 2-ANTE ALZANTE SCORREVOLE TELAIO 90°

	PROFILATI		QUANTITA'	TAGLIO	LUNGHEZZA TAGLIO	
1		C9K120	2		L - 57	
2		C9K121	2		H	
3		C9A100	2		H - 118	
4		C9V001	4 4		L/2 + 2 H - 100	
5		GCxxxx	4 4		L/2 - 162 H - 308	
6		C9A001	2		H - 184	
7		C9A003	1		L - 54	
8		CO1103	2		L - 71	
9		KU2028	2		L - 57	
10		KU2035	2		H - 118	
11		KU2027	4 4		L/2 - 55 H - 157	
12		KU2029	2		H - 104	
13		CO2181	2		H - 104	
<b>DIMENSIONI VETRI</b>					L/2 - 176	H - 278

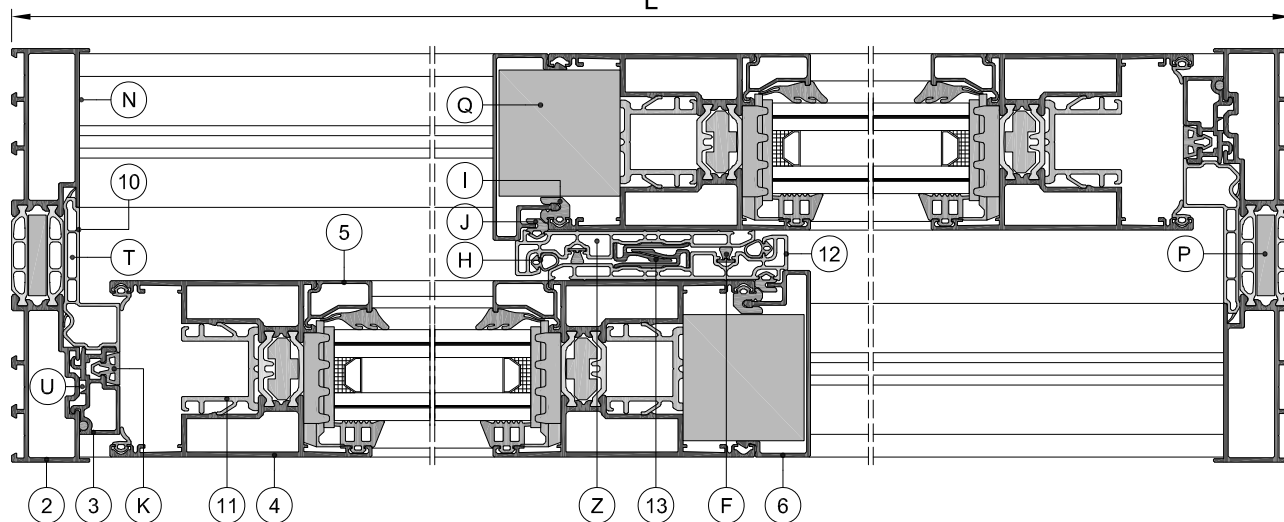
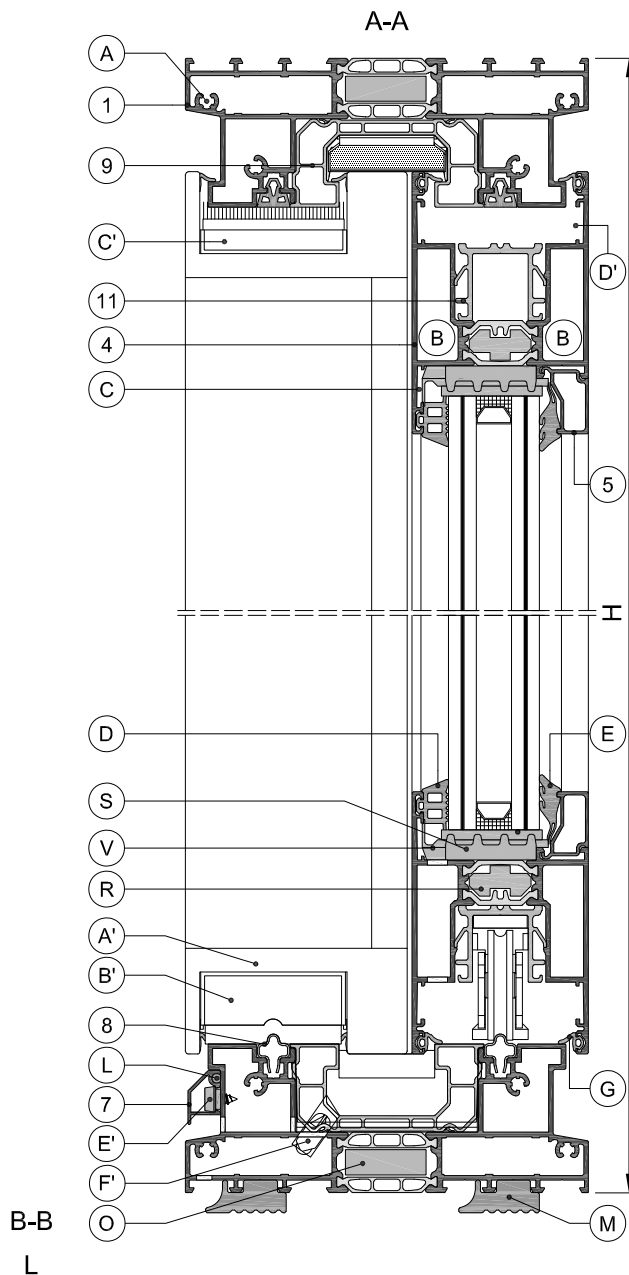
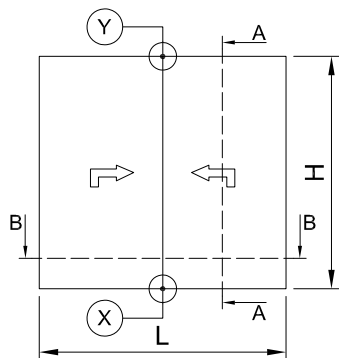



## 2-BINARI 2-ANTE ALZANTE SCORREVOLE TELAIO 90°

	ACCESSORI	QUANTITA'
<b>A</b>	787-570	16
<b>B</b>	HV3H26 / 778500 / 71C011	16 / 32 / 32
<b>C</b>	HV4K00 / HV4K01	16 / 8
<b>D</b>	RU0002	2L + 4H
<b>E</b>	39R507	2L + 4H
<b>F</b>	KU6004	2H
<b>G</b>	RU0099	4L + 4H
<b>H</b>	RU9095	2H
<b>I</b>	RU9094	2H
<b>J</b>	RU9703	2H
<b>K</b>	RU9704	2L + 2H
<b>L</b>	213-006	L + 2H
<b>M</b>	RU9079 - FACOLTATIVA	2L
<b>N</b>	VS9956	4
<b>O</b>	BT6006-VERSIONE SI	2L
<b>P</b>	BT6019-VERSIONE SI	2H

	ACCESSORI	QUANTITA'
<b>Q</b>	BT6013-VERSIONE SI	2H
<b>R</b>	BT6000-VERSIONE SI	2L + 4H
<b>S</b>	KU5001-VERSIONE SHI	2L + 4H
<b>T</b>	VS9957	4
<b>U</b>	CO0132	4
<b>V</b>	VS5130	16
<b>X</b>	CO1105	1
<b>Y</b>	CO1111	1
<b>Z</b>	VS9148 (set)	2
<b>A'</b>	VS9149 (set)	2
<b>B'</b>	CO1107	2
<b>C'</b>	CO1110	2
<b>D'</b>	VS5131	8
<b>E'</b>	CO2279	3/m
<b>F'</b>	VS0107	1
	D4074009	VEDI PAG. J.1.4
	SV9002	1

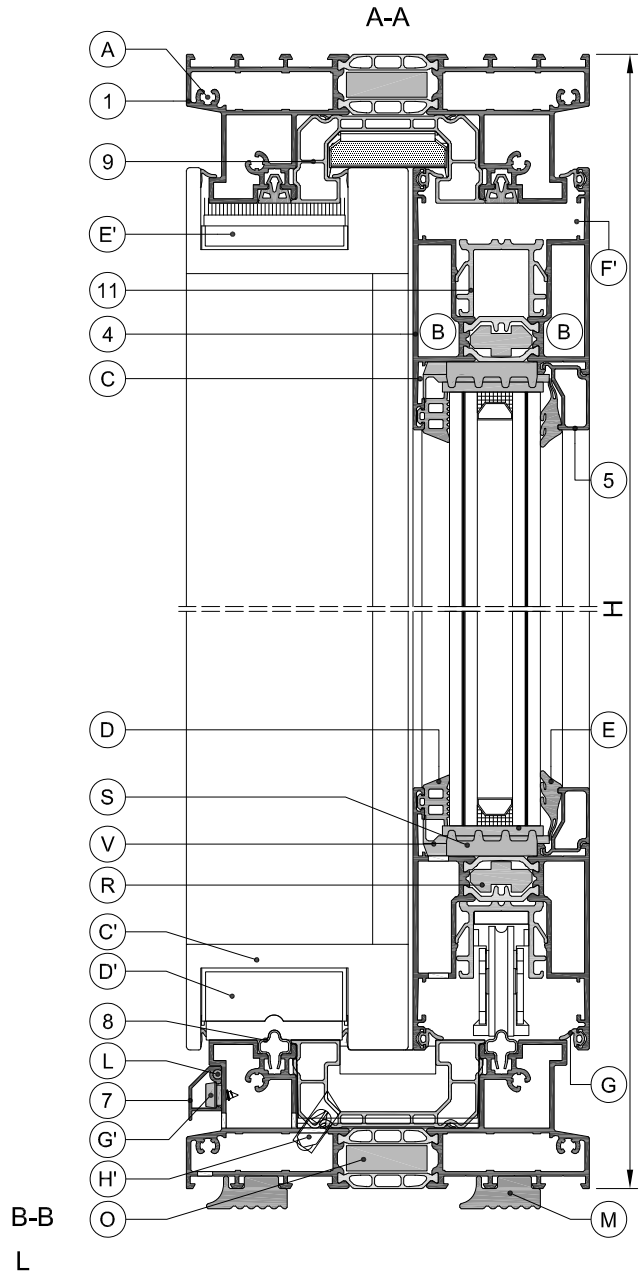
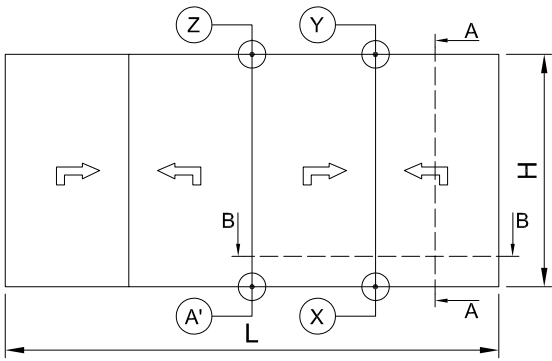





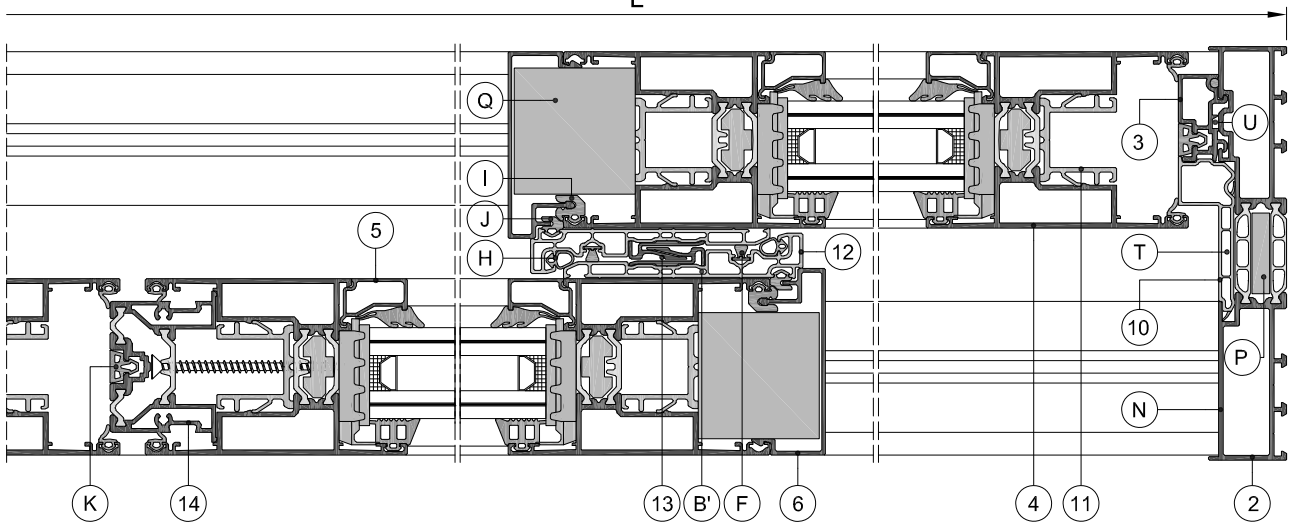























B-B

L



## 2-BINARI 4-ANTE ALZANTE SCORREVOLE TELAIO 90°

	PROFILATI		QUANTITA'	TAGLIO	LUNGHEZZA TAGLIO	
1		C9K120	2		L - 57	
2		C9K121	2		H	
3		C9A100	2		H - 118	
4		C9V001	4 4		L/4 + 19 H - 100	
5		GCxxxx	4 4		L/4 - 145 H - 308	
6		C9A001	2		H - 184	
7		C9A003	1		L - 54	
8		CO1103	1 1 1		L/2 - 10.5 L/2 - 50.5 L - 86	
9		KU2028	2		L - 57	
10		KU2035	2		H - 118	
11		KU2027	4 4		L/4 - 38 H - 157	
12		KU2029	4		H - 104	
13		CO2181	4		H - 104	
14		C9C002	1		H - 179	
<b>DIMENSIONE VETRI</b>					L/4 - 159	H - 278

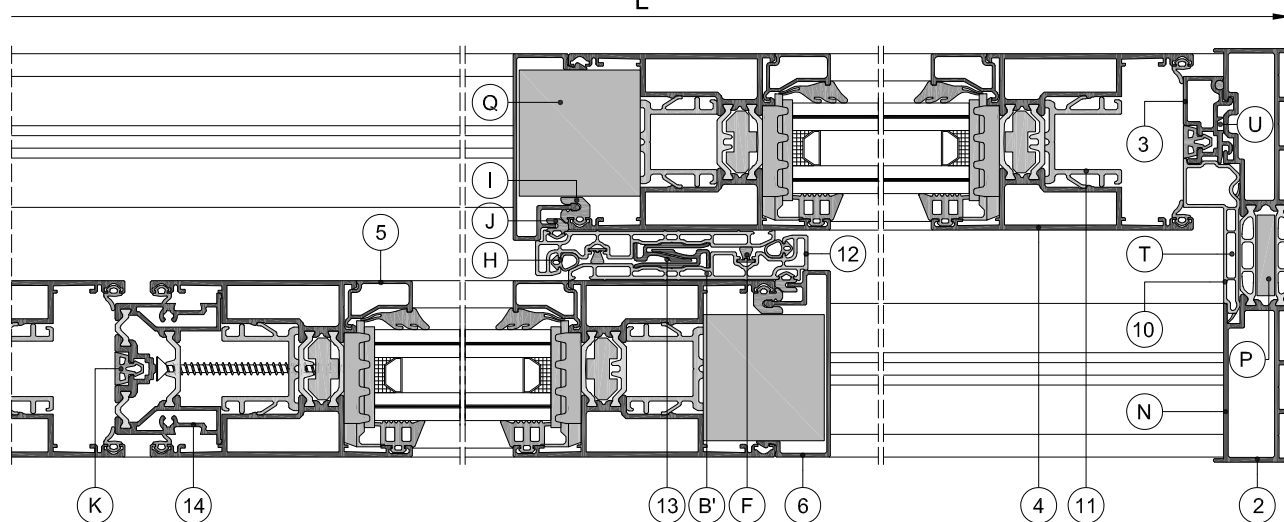
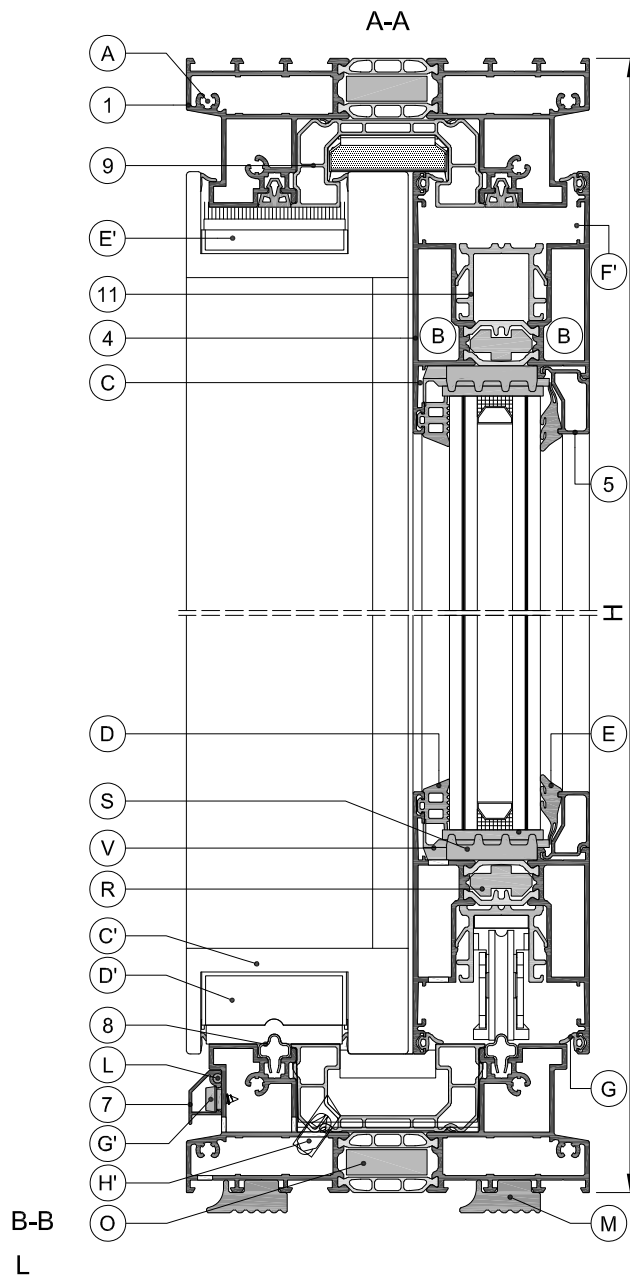
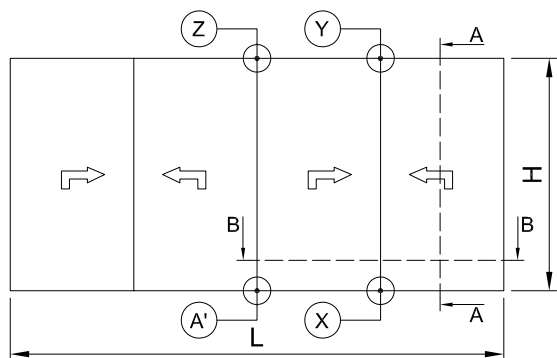

## 2-BINARI 4-ANTE ALZANTE SCORREVOLE TELAIO 90°

	ACCESSORI	QUANTITA'
<b>A</b>	787-570	16
<b>B</b>	HV3H26 / 778500 / 71C011	32 / 64 / 64
<b>C</b>	HV4K00 / HV4K01	32 / 16
<b>D</b>	RU0002	2L + 8H
<b>E</b>	39R507	2L + 8H
<b>F</b>	KU6004	4H
<b>G</b>	RU0099	4L + 8H
<b>H</b>	RU9095	4H
<b>I</b>	RU9094	4H
<b>J</b>	RU9703	4H
<b>K</b>	RU9704	2L + 3H
<b>L</b>	213-006	L + 2H
<b>M</b>	RU9079 - FACOLTATIVA	2L
<b>N</b>	VS9956	4
<b>O</b>	BT6006-VERSIONE SI	2L
<b>P</b>	BT6019-VERSIONE SI	2H
<b>Q</b>	BT6013-VERSIONE SI	4H



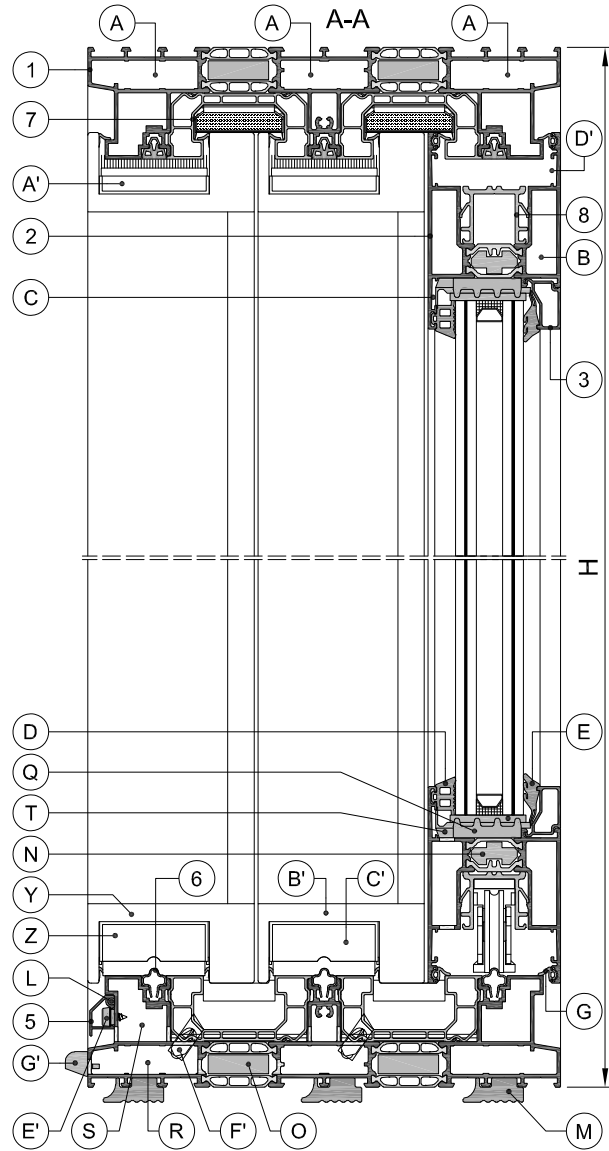
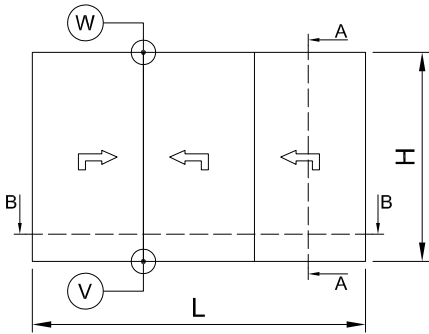



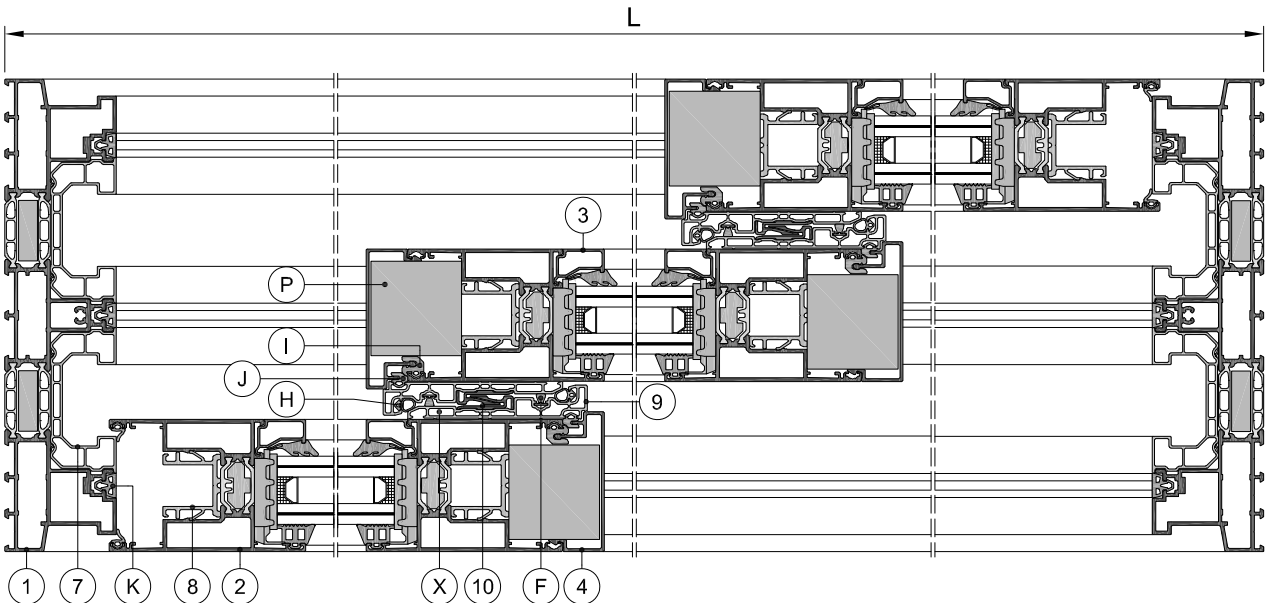













	ACCESSORI	QUANTITA'
<b>R</b>	BT6000-VERSIONE SI	2L + 8H
<b>S</b>	KU5001-VERSIONE SHI	2L + 8H
<b>T</b>	VS9957	4
<b>U</b>	CO0132	4
<b>V</b>	VS5130	32
<b>X</b>	CO1105	2
<b>Y</b>	CO1111	2
<b>Z</b>	CO1118	1
<b>A'</b>	CO1125	1
<b>B'</b>	VS9148 (set)	4
<b>C'</b>	VS9149 (set)	4
<b>D'</b>	CO1107	4
<b>E'</b>	CO1110	4
<b>F'</b>	VS5131	16
<b>G'</b>	CO2279	3/m
<b>H'</b>	VS0107	2
	D4074009	VEDI PAG. J.1.4
	CO1214	4
	SV9002	2



B-B



## 3-BINARI 3-ANTE ALZANTE SCORREVOLE TELAIO 45°

N°	PROFILATI		QUANTITA'	TAGLIO	LUNGHEZZA TAGLIO	
	Icona	Modello			L	H
1		C9K030	2 2		L	H
2		C9V001	6 6		L/3 + 18	H - 100
3		GCxxxx	6 6		L/3 - 146	H - 308
4		C9A001	4		H - 184	
5		C9A003	1		L - 44	
6		CO1103	3		L - 118	
7		KU2028	4 4		L - 48	H - 48
8		KU2027	6 6		L/3 - 39	H - 157
9		KU2029	4		H - 104	
10		CO2181	4		H - 104	
<b>DIMENSIONE VETRI</b>					L/3 - 160	H - 278

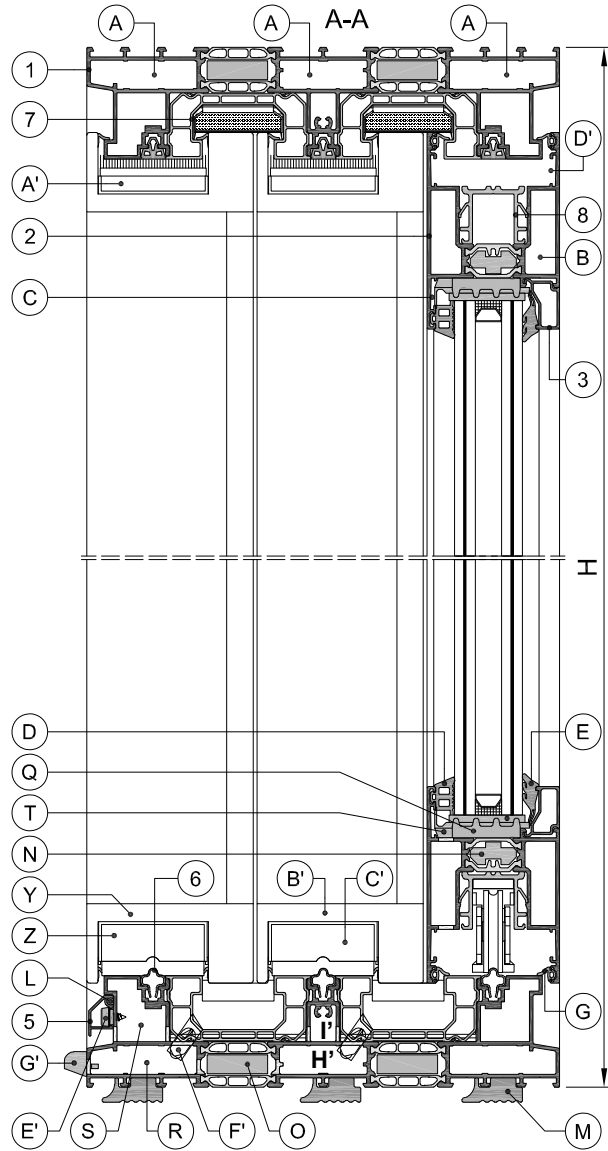
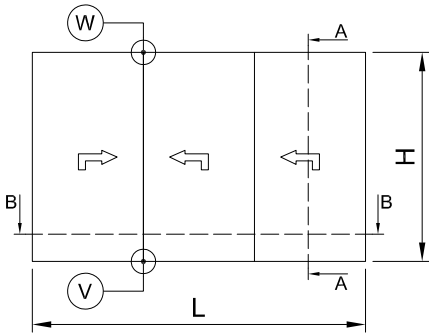

B-B

L

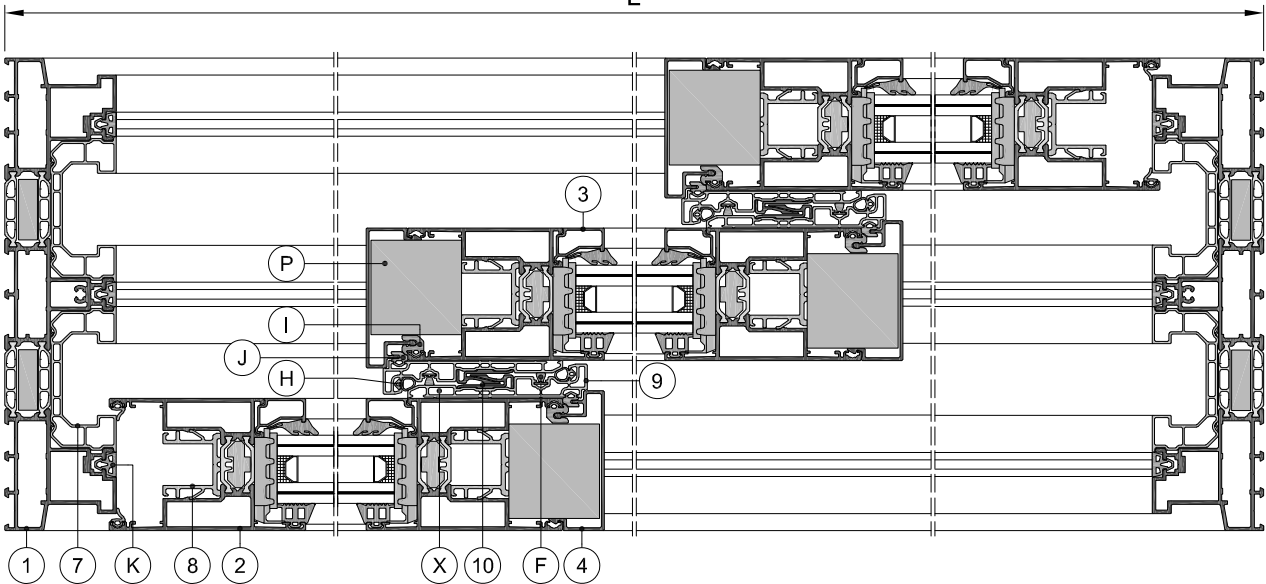



## 3-BINARI 3-ANTE ALZANTE SCORREVOLE TELAIO 45°

	ACCESSORI	QUANTITA'
<b>A</b>	HV0G03 / 778500	12 / 48
<b>B</b>	HV3H26 / 778500 / 71C011	24 / 48 / 48
<b>C</b>	HV4K00 / HV4K01	24 / 12
<b>D</b>	RU0002	2L + 6H
<b>E</b>	39R507	2L + 6H
<b>F</b>	KU6004	4H
<b>G</b>	RU0099	4L + 4H
<b>H</b>	RU9095	4H
<b>I</b>	RU9094	4H
<b>J</b>	RU9703	4H
<b>K</b>	RU9704	3L + 6H
<b>L</b>	213-006	L
<b>M</b>	RU9079 - FACOLTATIVA	3L
<b>N</b>	BT6000-VERSIONE SI	2L + 6H
<b>O</b>	BT6006-VERSIONE SI	4L + 4H
<b>P</b>	BT6013-VERSIONE SI	4H
<b>Q</b>	KU5001-VERSIONE SHI	2L + 6H

	ACCESSORI	QUANTITA'
<b>R</b>	VS9950	4
<b>S</b>	VS9951	2
<b>T</b>	VS5130	24
<b>V</b>	CO1107	4
<b>W</b>	CO1111	2
<b>X</b>	VS9148 (set)	4
<b>Y</b>	VS9149 (set)	4
<b>Z</b>	CO1105	2
<b>A'</b>	CO1110	4
<b>B'</b>	VS9163	1
<b>C'</b>	CO1127	1
<b>D'</b>	VS5131	12
<b>E'</b>	CO2279	3/m
<b>F'</b>	VS0107	2
<b>G'</b>	D4074009	VEDI PAG. J.1.4
<b>H'</b>	VS9964	2
<b>I'</b>	VS9965	2
	SV9002	2



**Ferramenta & disegni  
assemblaggio**



### ASSEMBLAGGIO GENERALE - E SPECIFICHE DI MONTAGGIO IN OFFICINA

Oltre alle tecniche e termini determinati dalle norme ufficiali (Nazionali ed Europee), alcune regole di base devono essere rispettate durante il montaggio e l'installazione di una finestra per produrre un prodotto di qualità.

Nel seguente, elenco, non limitato, le specifiche sono date per la costruzione, produzione e posa di finestre-, porte-, elementi di facciate.

#### 1. Tagliare il profilato

Al fine di ottenere un buon taglio, è importante fissare bene e posizionare il profilato sulla troncatrice.

Il profilo deve sempre essere posizionato in modo tale che i lati del profilato vengano premuti accuratamente contro la troncatrice per mezzo di pistoni. Il profilato deve essere fissato in modo tale che non abbia la tendenza di spostarsi o stortarsi.

esempio: Tipico serraggio di un profilato con aletta:

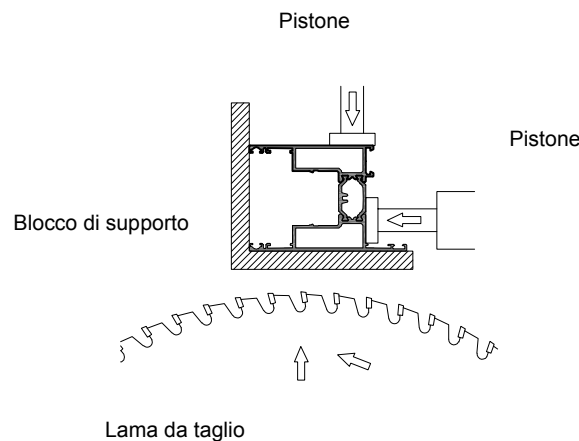

#### 2. Punzonatura, fresatura o foratura

Dopo che i profilati sono statilavorati, le superfici devono essere sbavate, sgrassate e trattate con un prodotto anti-corrosione.

In aggiunta, l'attenzione deve essere prestata durante il trattamento, che nessun danno si verifichi sulla superficie. Questa è la causa della corrosione filiforme.

Tipici esempi di questi processi sono:

- Forature, fresature o forature per drenaggio e ventilazione
- Fresature o punzonature per assemblaggio profilati
- Forature per il fissaggio dei profilati
- ...

#### 3. Accoppiamenti profilati

I tagli e i cavallotti devono essere sigillati a fondo con sigillante neutro approvato, in modo tale che i requisiti di tenuta all'aria e impermeabilità siano soddisfatti.

Imponendo i necessari requisiti per l'accoppiamento del profilato, viene fatta una distinzione tra:

- Profilati pre-assemblati finestre/porte/costruzioni in alluminio:

Le sigillature sui lati visibili non possono essere più grandi di 0,3 millimetri. La disuguaglianza di connessione profilati misurata sulle superficie di costruzione presso le giunzioni e connessioni a T, non può essere superiore alla tolleranza di estrusione come descritto nella norma EN 12020.

Come conseguenza della irregolarità (concavità e convessità) dei profilati, non è sempre possibile soddisfare i requisiti dovuti alla disuguaglianza della connessione profilati; perché questa differenza non può essere superiore a 0,5 mm.

Appartenenti a questo gruppo sono i profilati per la finitura delle finestre: profilati montanti, finitura stipite, adattatori, davanzali su telaio, ... Questi hanno bisogno di essere sempre sigillati per tenuta all'aria e all'acqua con un sigillante neutro ed elastico. Per alcuni dei sigillanti specifici, vedere i dettagli rilevanti nel catalogo.

- Connessioni profilati per parti collegate durante la costruzione.

Questi trattengono parti in vetro, parti pannellate e parti di costruzione collegate durante la costruzione. Con questi, gli interspazi e connessioni tra profilati dovranno essere scelti in modo tale che con differenze di temperatura il loro funzionamento sarà indisturbato.

I giunti tra travi orizzontali e verticali di facciate in vetro non possono essere più grande di 2mm, escluse le tolleranze profilati, giunti più grandi devono essere sigillati con un prodotti adeguati. Appartenenti a questo gruppo sono i profilati necessari al completamento dell'intera costruzione: montanti d'angolo, cornici collegate, profilati di rinforzo, come collegare i profili, .... Questi devono essere sempre sigillato per tenuta aria e per evitare infiltrazioni d'acqua.

#### 4. Drenaggio

È importante evitare il più possibile infiltrazioni di acqua piovana nelle scanalature. L'acqua trasporta lo sporco, che andranno a formare depositi nelle cavità. Sporczia e acqua mettono a dura prova guarnizioni e trattamenti superficiali.

Misure per prevenire l'infiltrazione di acqua piovana:

- Tagli e connessioni di travi verticali su travi orizzontali, nonché la reciproca connessione con la vetratura - e le gomme di tenuta, necessitano avere un appropriato, dove necessario elastico, sigillante per evitare la penetrazione di acqua piovana.
- Per evitare che l'acqua piovana venga ritenuta nelle finestre, la pressione dell'aria nelle cavità deve essere uguale alla pressione atmosferica esterna, cosiddetta equalizzazione della pressione. Pertanto, le cavità devono avere aperture che vanno rifinite il più possibile ermeticamente verso l'interno. Per ulteriori dettagli, vedi più avanti nel catalogo.
- Utilizzare gli schemi per scarico acqua prescritti al fine di garantire un buon drenaggio.
- Rispettare la distanza regolare tra i fori di drenaggio. Per dettagli sul posizionamento, vedere più avanti nel catalogo.
- Lo scarico di drenaggio tra il telaio fisso e la parte apribile deve avere una distanza minima vicino agli angoli, con una superficie almeno di 50 mm<sup>2</sup> per apertura, sia se si tratta di fori tondi con un diametro minimo di 8 mm, o una asola da 5mm per 15mm. (la norma provvisoria prEN 12488 prevede 20 mm).
- Con finestre a ghigliottina, porte e facciate continue, il drenaggio può deviare dalla suddetta regola, seguendo, le regole imposte dal proprietario del sistema.

#### 5. Guarnizioni

Le guarnizioni per vetratura, guarnizioni di tenuta all'acqua o all'aria e anche di tenuta acustica, sono normalmente prodotte in EPDM, TPE (gomme termoplastiche) o gomme siliconiche.

Le giunzioni di queste guarnizioni possono essere realizzate come segue:

- Incollaggio con adesivi compatibili.
- Telai vulcanizzati o angoli vulcanizzati.
- Guarnizioni continue.

Le guarnizioni dovranno essere installate prevedendo una lunghezza extra per ritiro:  $\pm 1\%$ .

#### 6. Installazione della vetratura

Il buon funzionamento della finestra dipende dalla corretto inserimento della vetratura. Il posizionamento dipende dal tipo di finestra.

Vanno utilizzati i prescritti supporti vetro, che sono particolarmente adatti e su misura per le specifiche serie.

## DIRETTIVE GENERALI

### 7. Fissaggio telai

Il fissaggio (staffe finestre, tappi, etc...) sono necessari in numero tale da resistere alla normale pressione dell'aria e qualsiasi altro carico possibile con un coefficiente di sicurezza 3, senza deformazioni permanenti.

Essi saranno posizionati ad una distanza massima di 750 mm tra di loro e circa a 200 mm di distanza da ogni angolo o trave del telaio fisso.

Con le presenza di parti apribili di finestre o porte, il fissaggio dovrà essere posizionato vicino al punto, raccomandato di apertura o chiusura..

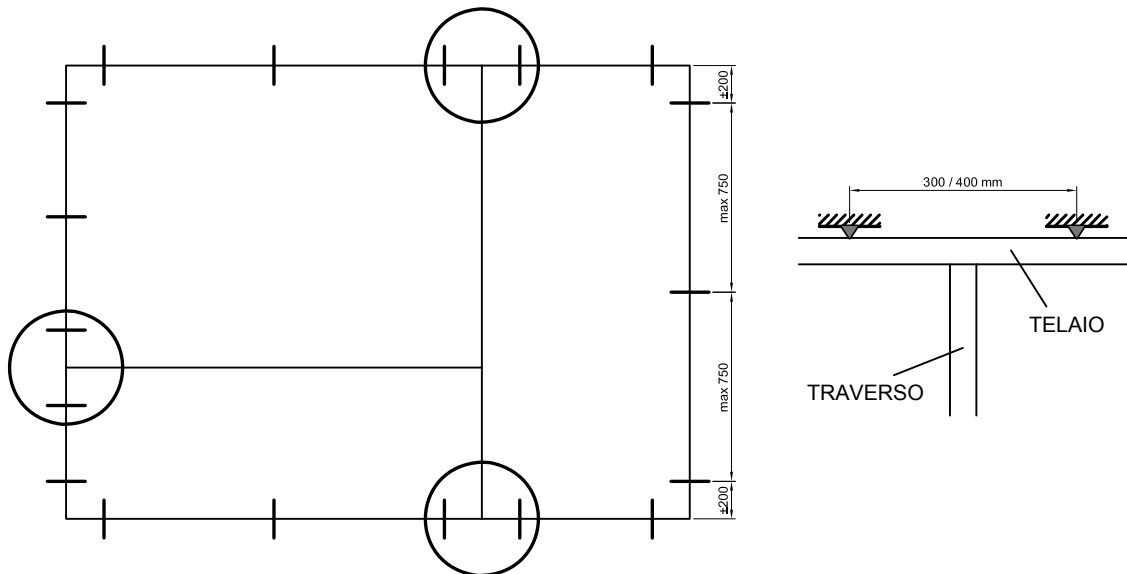

### 8. Contatti con altri materiali.

Se due metalli con un diverso potenziale elettrochimico sono in contatto tra loro in un ambiente umido, il metallo meno prezioso si corrode. Con i seguenti materiali, in particolare, saranno da prendere alcune misure preventive per evitare la corrosione: acciaio, rame, zinco e piombo.

Alcuni tipi di legni, come rovere e noce, rilasciano un tipo di acido che può danneggiare il metallo, in particolare in un ambiente umido o se il legno non è completamente essiccato. E' raccomandato in questo caso di isolare il metallo.

Gesso o cemento in aria umida o l'irrorazione di gesso o cemento hanno un impatto sulla superficie dell'alluminio, che potrà presentare segni bianchi dopo la pulizia, anche su superfici anodizzate. La protezione dell'alluminio durante la fase di costruzione sarà garantita applicando un foglio protettivo o un nastro con raccomandazione che l'adesivo non sia aggressivo. Per la finitura di intonaci interni ed esterni con la costruzione in alluminio, è consigliato l'uso di un profilato di limitazione della parte intonacata.

Altri materiali: si dovrebbe avere certezza che i materiali usati, che vengono a contatto con l'alluminio non producano reazioni chimiche con l'alluminio e con lo strato protettivo (trattamenti superficiali).

### 9. Profilati plastici

Tutti i profilati plastici deve essere conservati per almeno 24 ore a una temperatura ambiente di almeno + 15 ° C prima di essere utilizzati. Potrebbero esserci eventuali danni e rotture dovute alla fragilità del materiale se freddo.

**DRENAGGIO "LATO BAGNATO"**

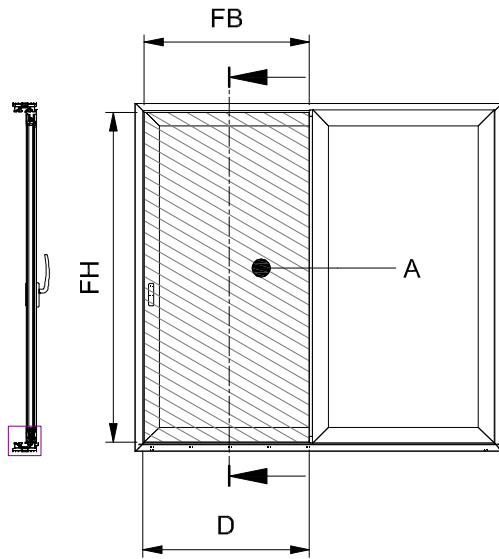
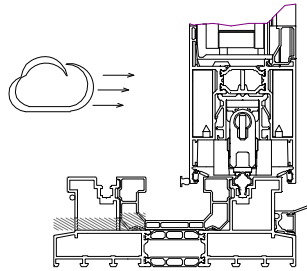
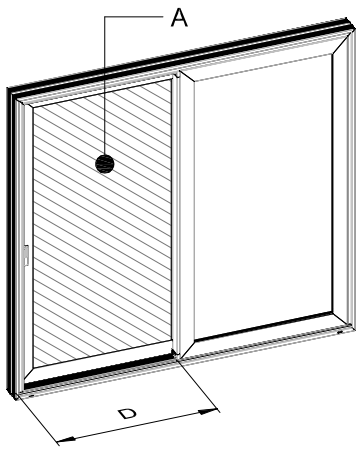

$$A \text{ (m}^2\text{)} = FB \times FH = N$$

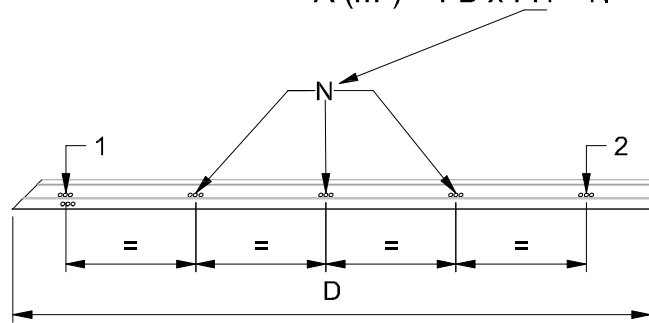
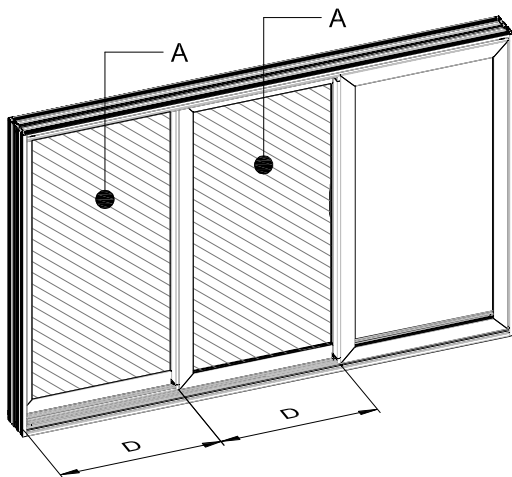

**Glossario:**

- D: lunghezza gocciolatoio esposto alle intemperie, necessità drenaggio
- A: superficie anta esposta alle intemperie in m<sup>2</sup>
- N: numero di scarichi aggiuntivi, ad intervallo equidistante tra scarichi 1 and 2. N = valore arrotondato di A

**Esempio:**

A = 2,4 m<sup>2</sup> → N = 2 → numero totale di scarichi per anta = 4

A = 2,6 m<sup>2</sup> → N = 3 → numero totale di scarichi per anta = 5

**Vedi:**

- J.2.10 J.2.15
- J.3.11 J.3.16
- J.4.11 J.4.16 J.4.18
- J.5.10 J.5.15 J.5.17
- J.5.10 J.5.17

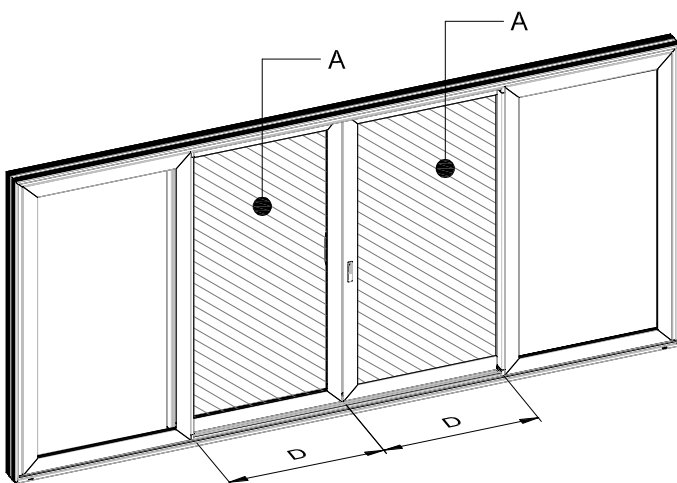



## DIRETTIVE GENERALI

### DIRETTIVE GENERALI PER VITI E CLIPS

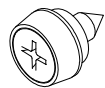
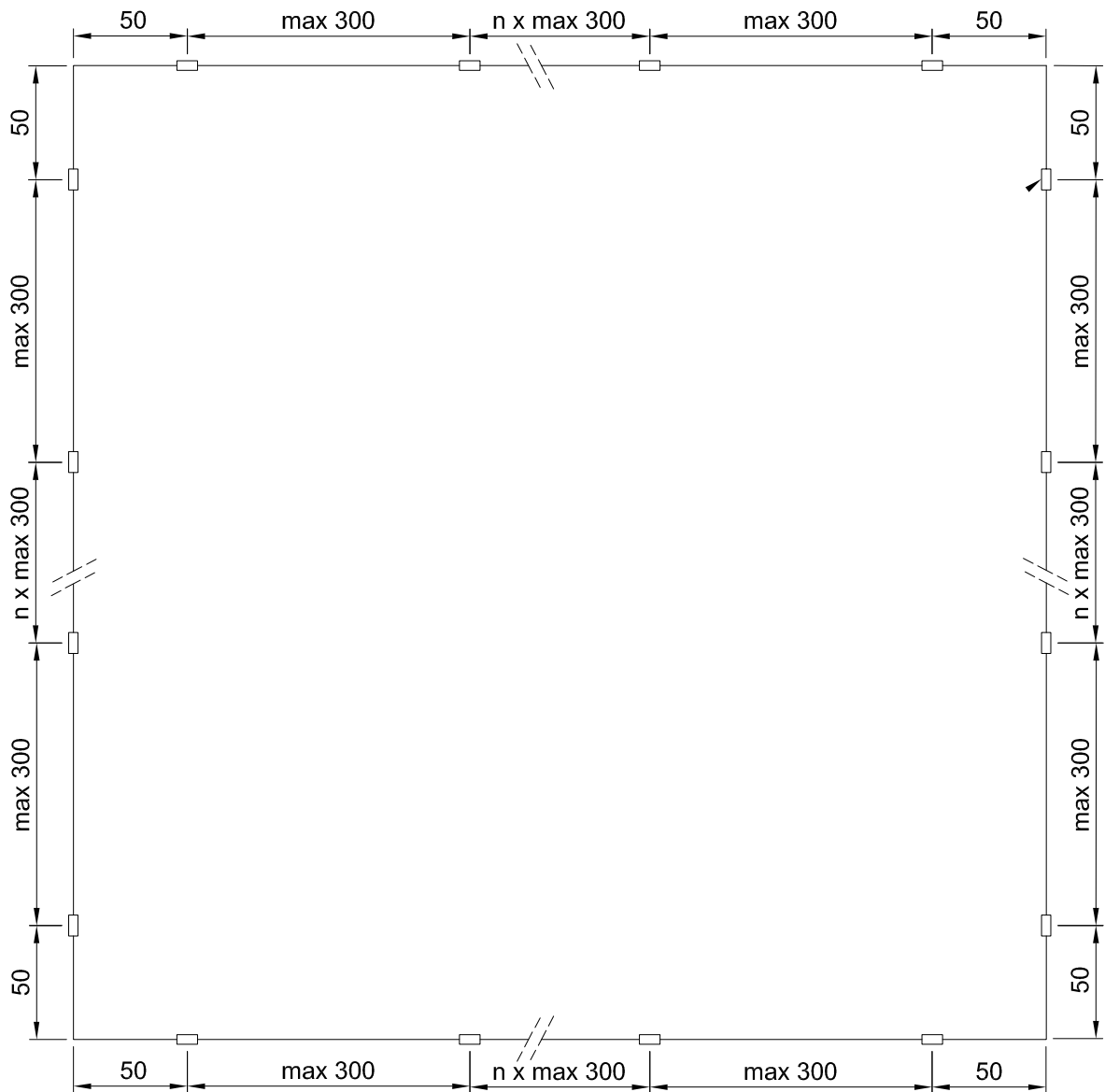

CO2279

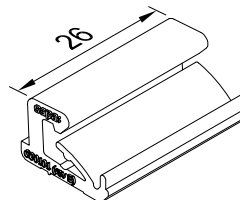

CO0101

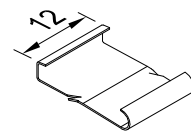

71C030



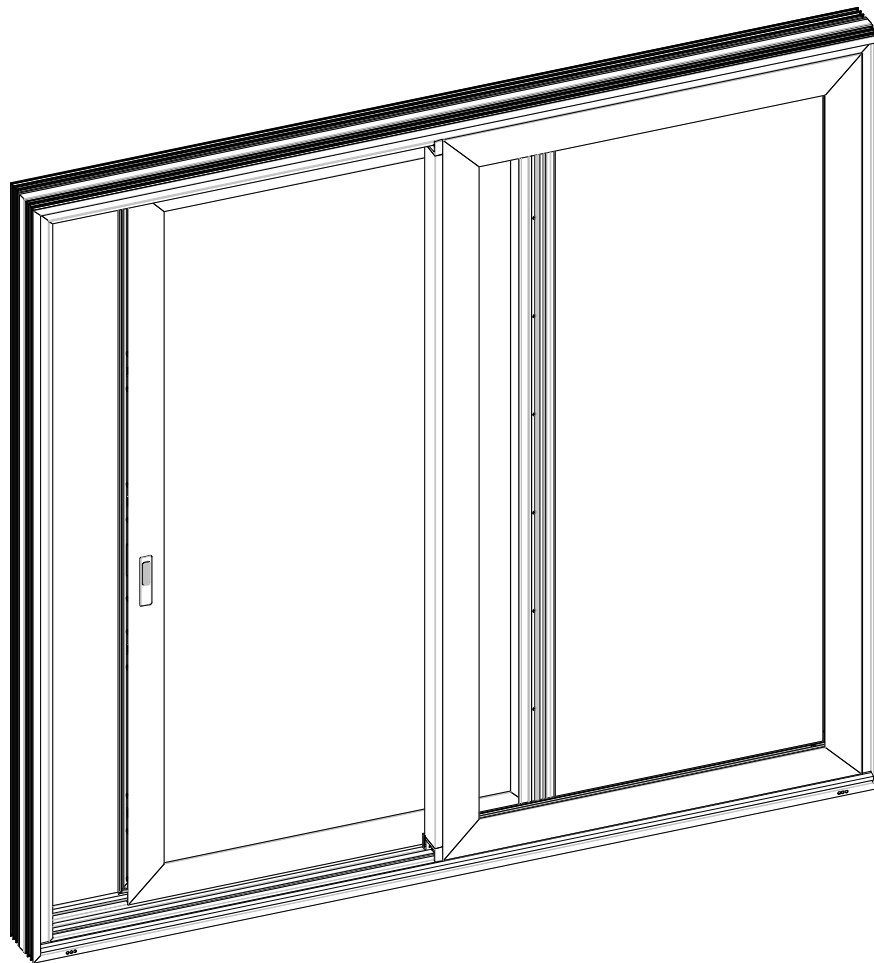

PANORAMICA ASSEMBLAGGIO

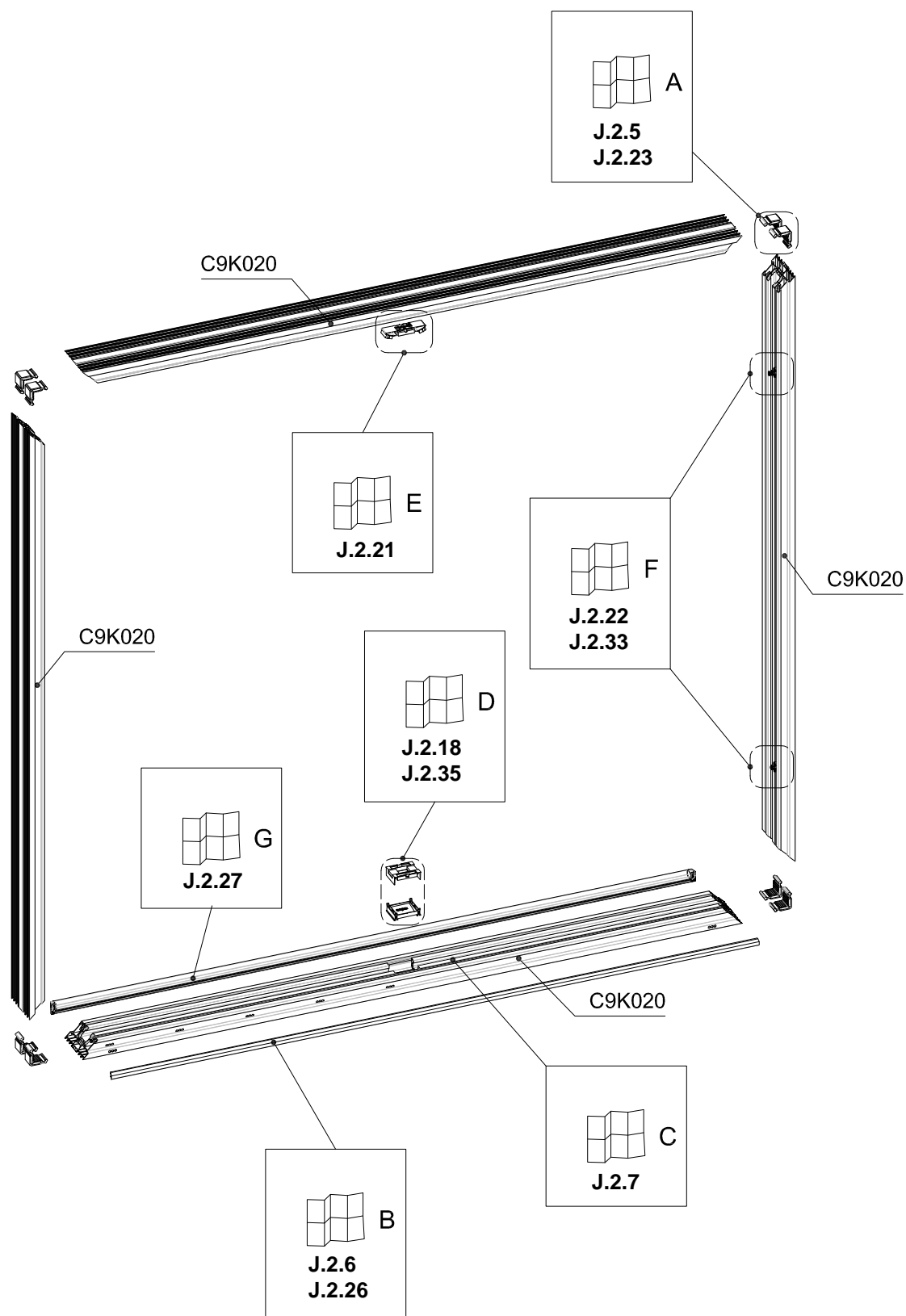

### CONTENUTO

2-binari telaio tagli 45° .....	J.2.1
Panoramica assemblaggio .....	J.2.2
Contenuto .....	J.2.3



Operazioni C9K020 + KU2028 e assemblaggio BT6006 .....	J.2.4
Lavorazione squadrette per C9K020 .....	J.2.5



Operazioni C9K020 per cappetta di drenaggio .....	J.2.6
C9K020 + KU2028 panoramica drenaggi .....	J.2.7
C9K020 lavorazione drenaggio - J (optional 1/2) .....	J.2.8
C9K020 lavorazione drenaggio - J (optional 2/2) .....	J.2.9
C9K020 lavorazione drenaggio - H .....	J.2.10
C9K020 lavorazione drenaggio - B .....	J.2.11
C9K020 lavorazione drenaggio - A .....	J.2.12
C9K020 lavorazione drenaggio - G .....	J.2.13
C9K020 lavorazione drenaggio - M .....	J.2.14
KU2028 lavorazione drenaggio - K1 .....	J.2.15
KU2028 lavorazione drenaggio - K2 .....	J.2.16



Assemblaggio VS0107 e KU2028 su C9K020 profilato inferiore C9K020 .....	J.2.17
Assemblaggio tappo centrale CO1105 profilato inferiore C9K020 .....	J.2.18
Sigillatura profilato inferiore C9K020 con VS9950 e VS9951 .....	J.2.20
Assemblaggio tappo centrale CO1111 profilato superiore C9K020 .....	J.2.21
Assemblaggio punti di chiusura - ZB0034/ZB0035/ZB0036 .....	J.2.22



Assemblaggio profilati telai con squadrette .....	J.2.23
Assemblaggio cappetta di drenaggio C9A003 .....	J.2.26
Operazioni C9A004 + VS2404 .....	J.2.27
Assemblaggio C9A004 + VS2404 .....	J.2.28
Assemblaggio C9A004 + VS2404 - optional .....	J.2.29
Assemblaggio CO1103 .....	J.2.30
Assemblaggio CO1103 con 1 anta funzionale .....	J.2.31
Assemblaggio CO1103 e ZB0038 per schema 4 ante .....	J.2.32
Assemblaggio punti di chiusura .....	J.2.33
Assemblaggio guarnizione di finitura RU9704 .....	J.2.34
Assemblaggio tappo centrale CO1105/CO1104 profilato inferiore C9K020 .....	J.2.35

**OPERAZIONI C9K020 + KU2028 E ASSEMBLAGGIO BT6006**

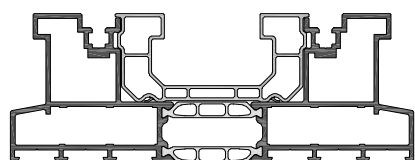
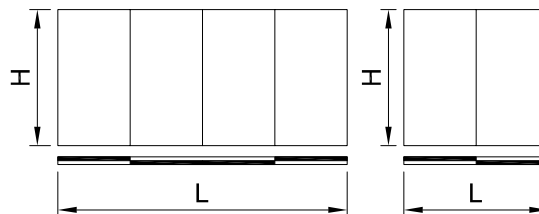
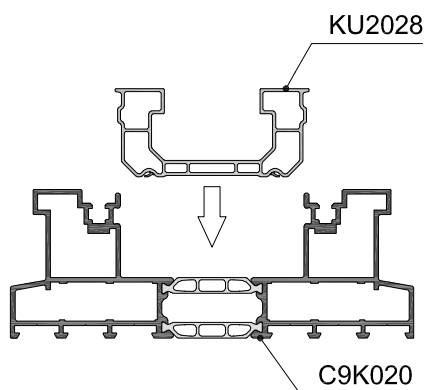

C9K020

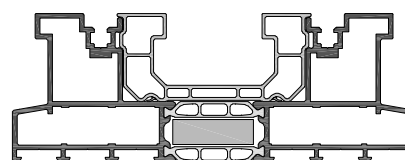
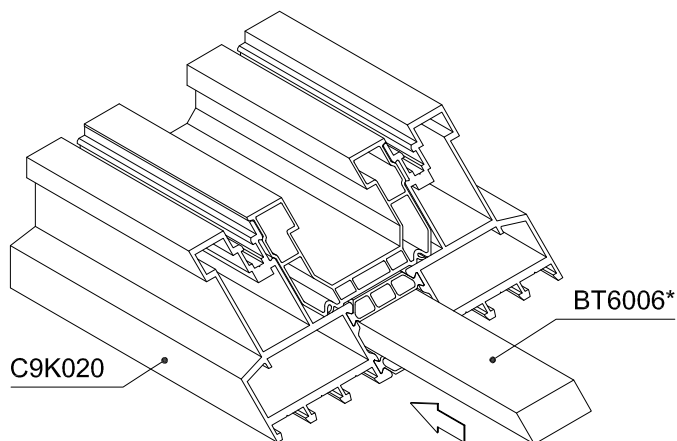
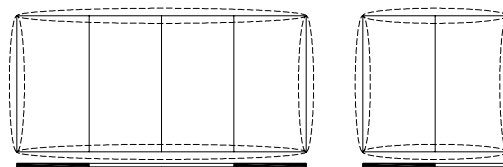
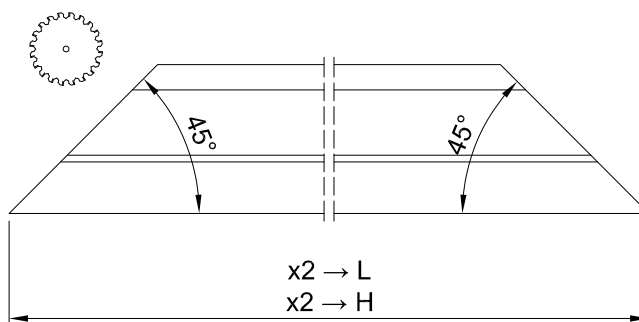

	BT6006
SHI	✓
SI	✓
I	x

## 2-BINARI TELAIO TAGLI 45°

### LAVORAZIONE SQUADRETTE PER C9K020

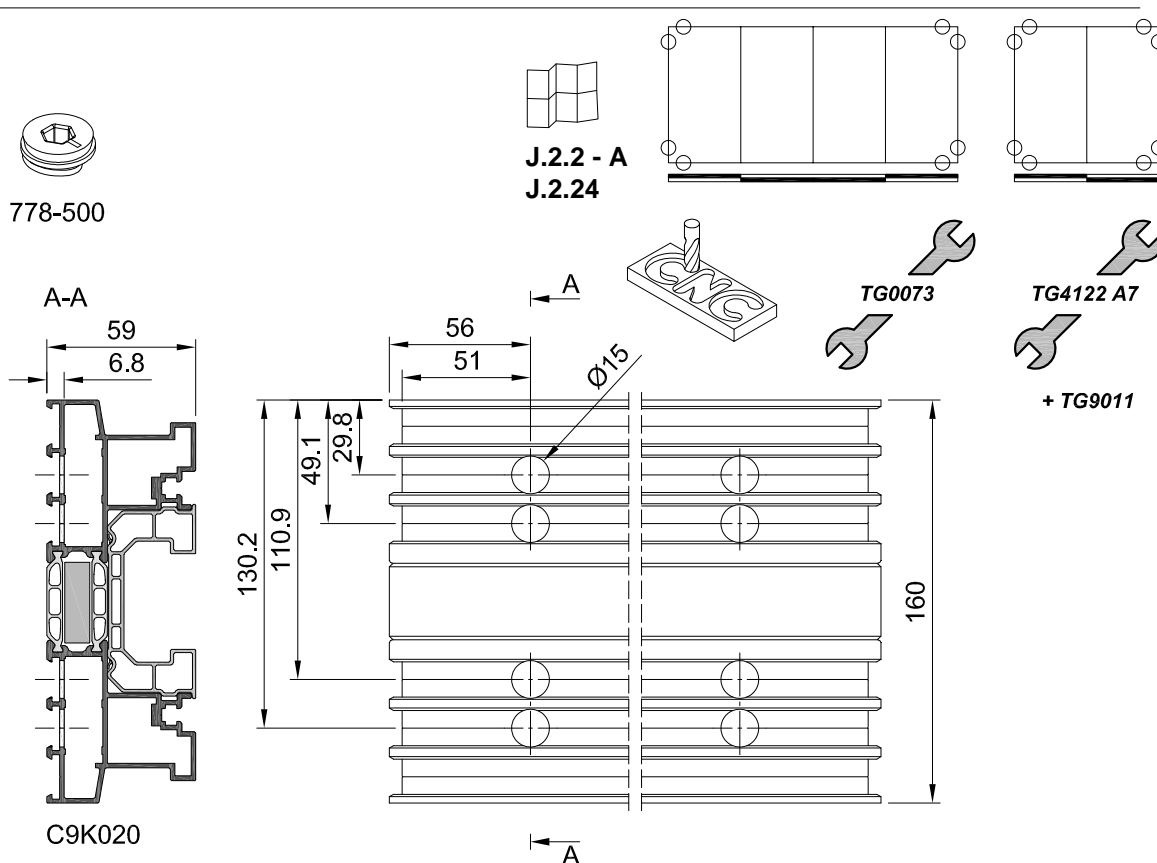
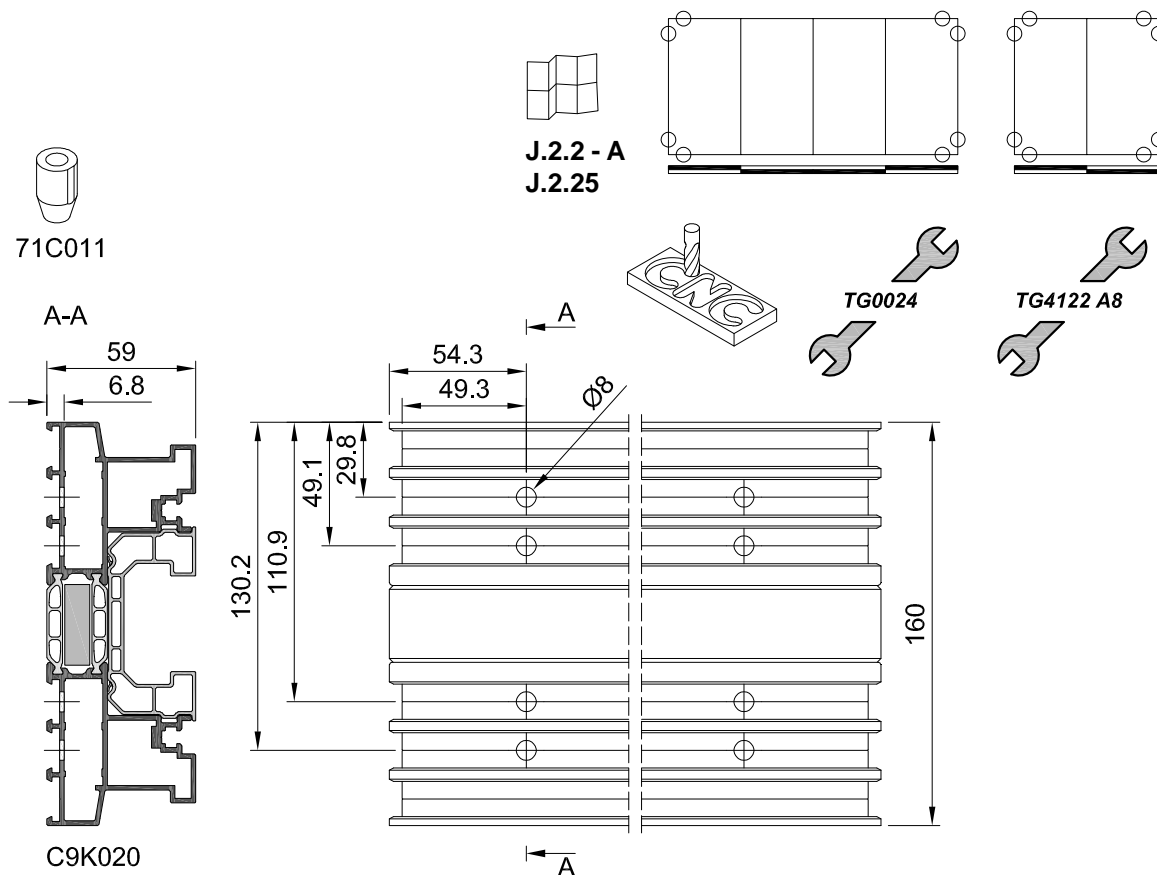

**C160-ASS-1301**

**OPERAZIONI C9K020 PER CAPPETTA DI DRENAGGIO**



J.2.2 - B  
J.2.26

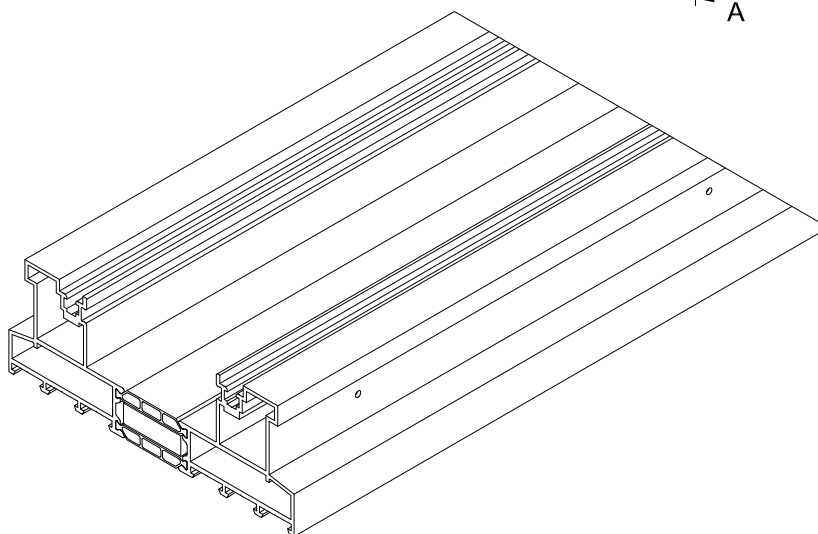
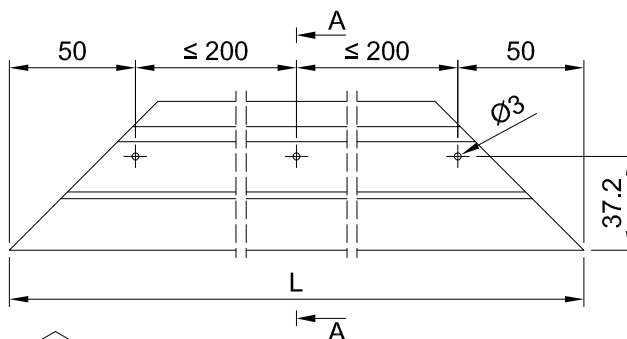
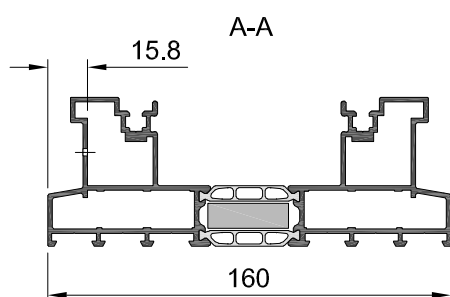
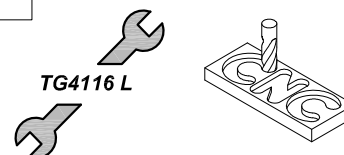
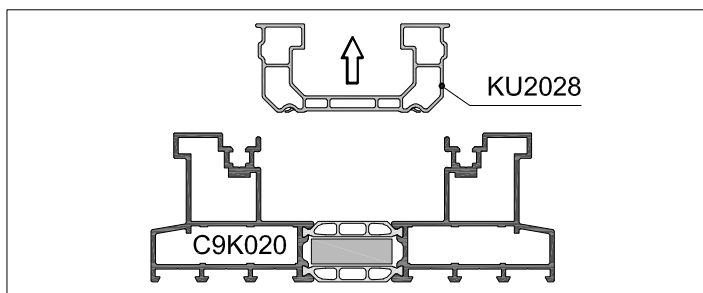
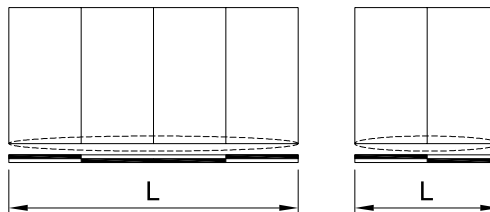



## 2-BINARI TELAIO TAGLI 45°

### C9K020 + KU2028 PANORAMICA DRENAGGI

1 / 11

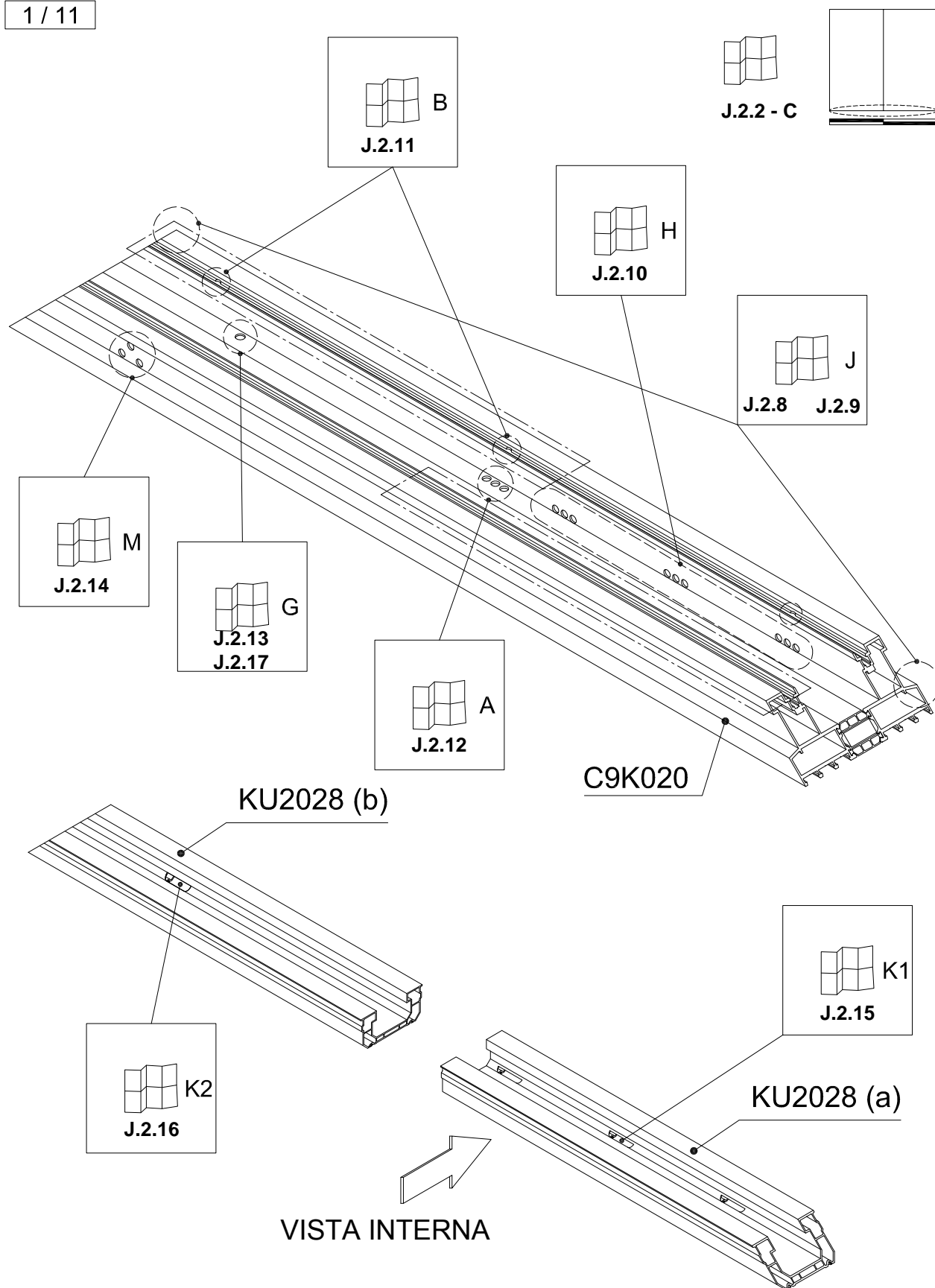

**C9K020 LAVORAZIONE DRENAGGIO - J (OPTIONAL 1/2)**

2 / 11

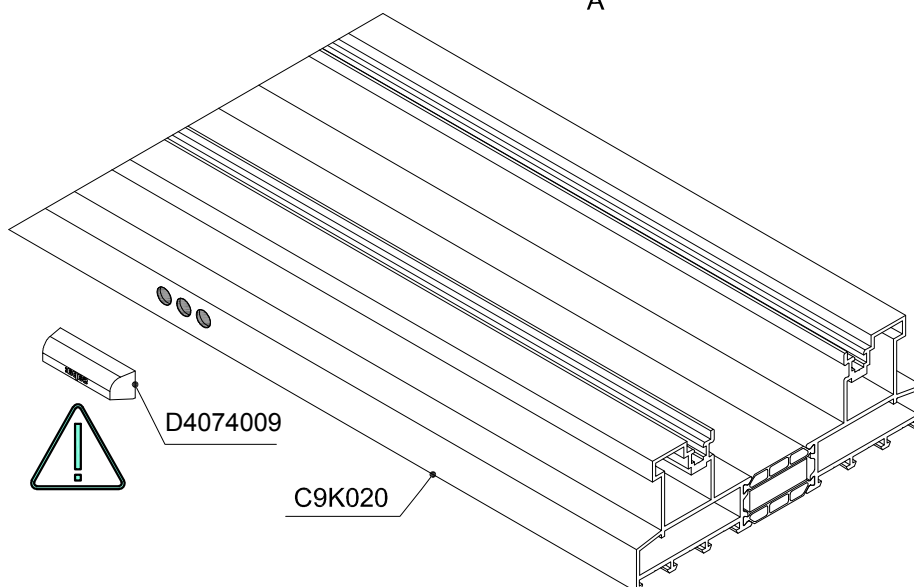
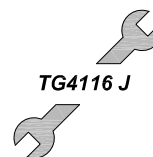
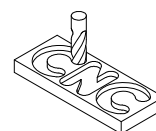
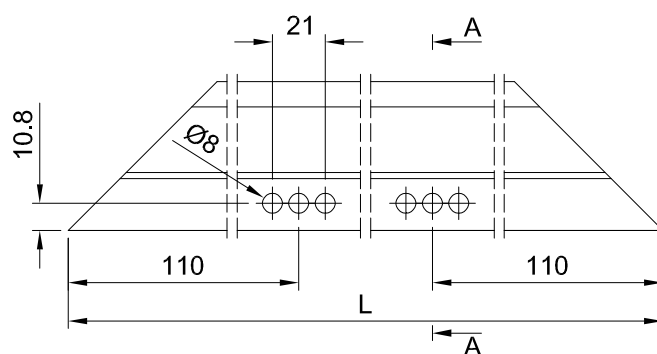
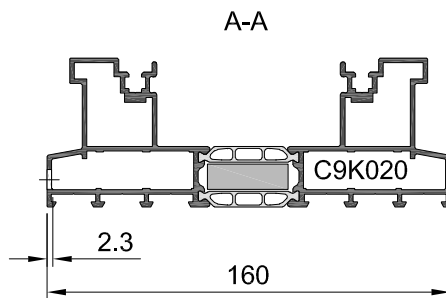
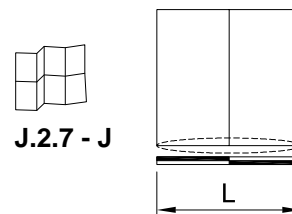

2-BINARI TELAIO TAGLI 45°

C9K020 LAVORAZIONE DRENAGGIO - J (OPTIONAL 2/2)

3 / 11

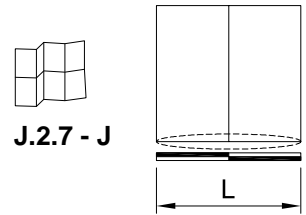

A-A

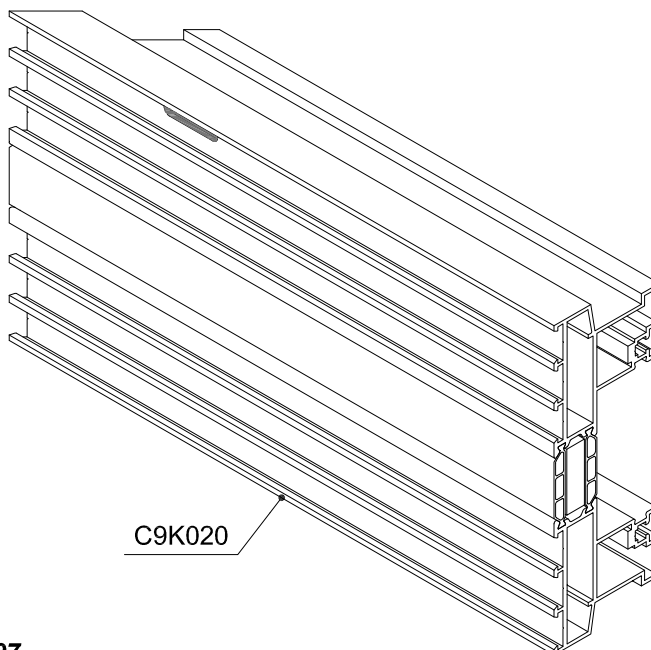
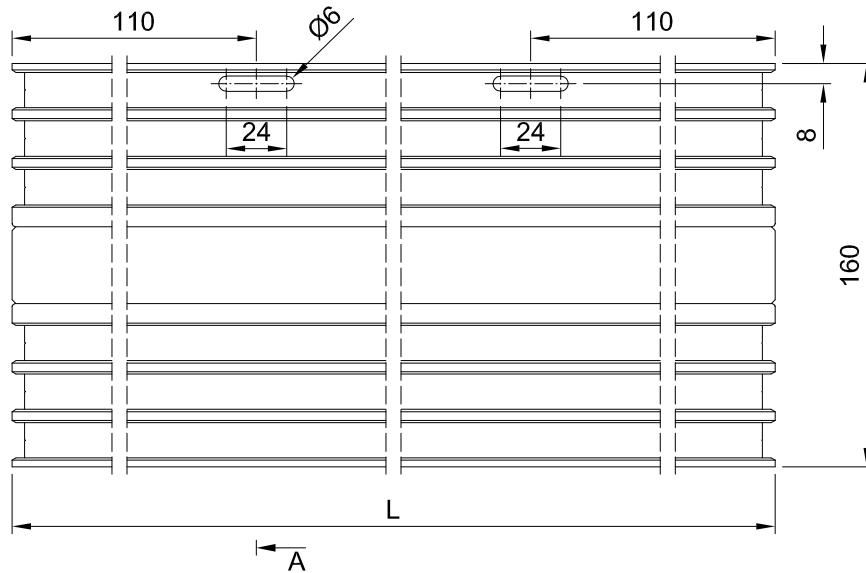
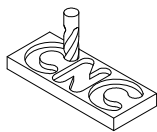
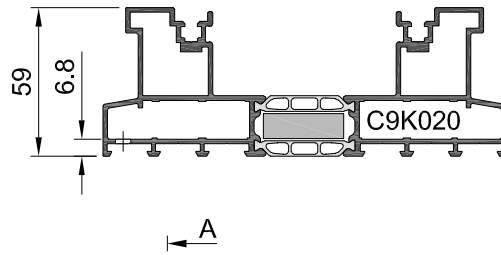

**C9K020 LAVORAZIONE DRENAGGIO - H**

4 / 11



J.2.7 - H  
 X → J.1.4

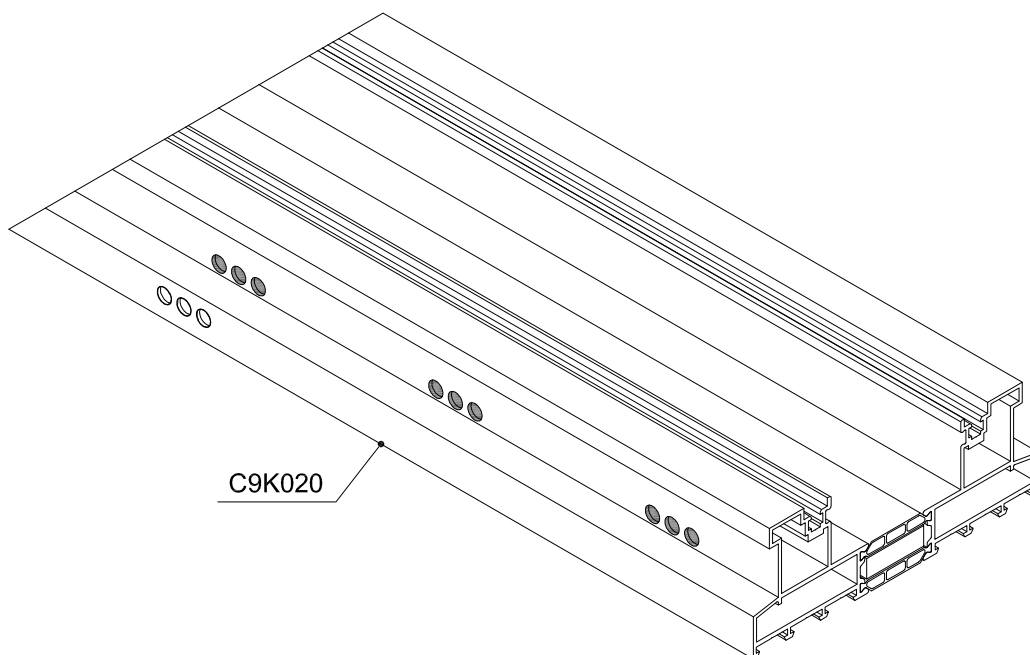
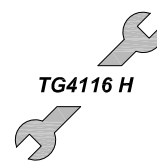
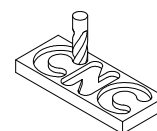
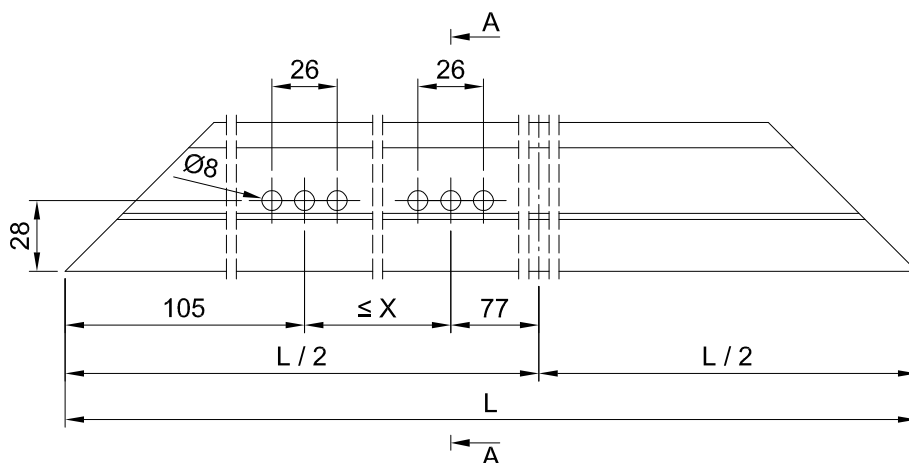
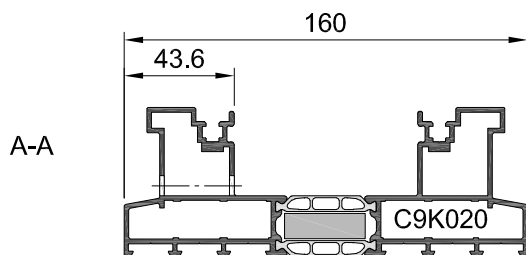
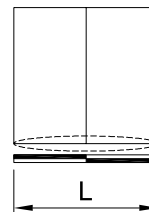

2-BINARI TELAIO TAGLI 45°

C9K020 LAVORAZIONE DRENAGGIO - B

5 / 11

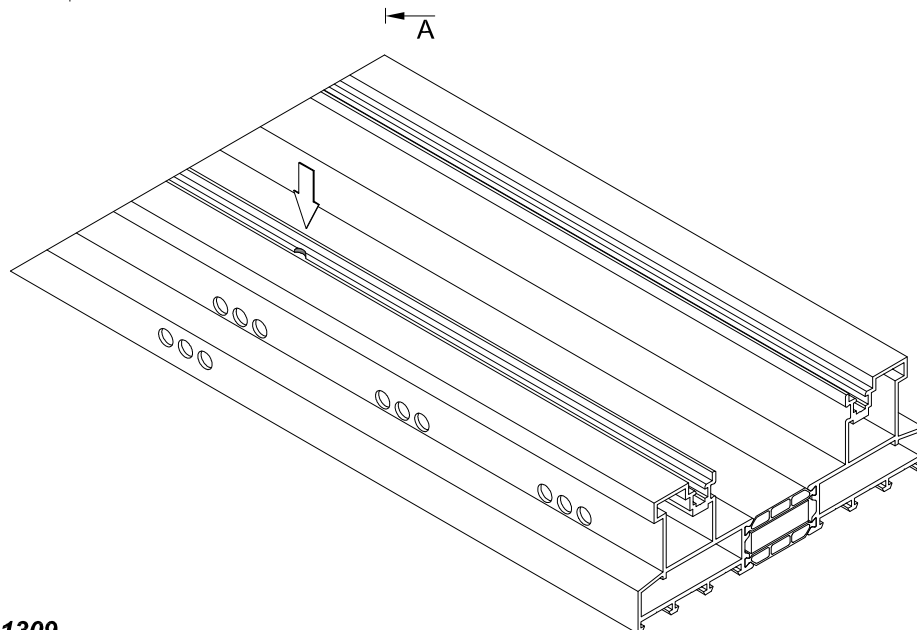
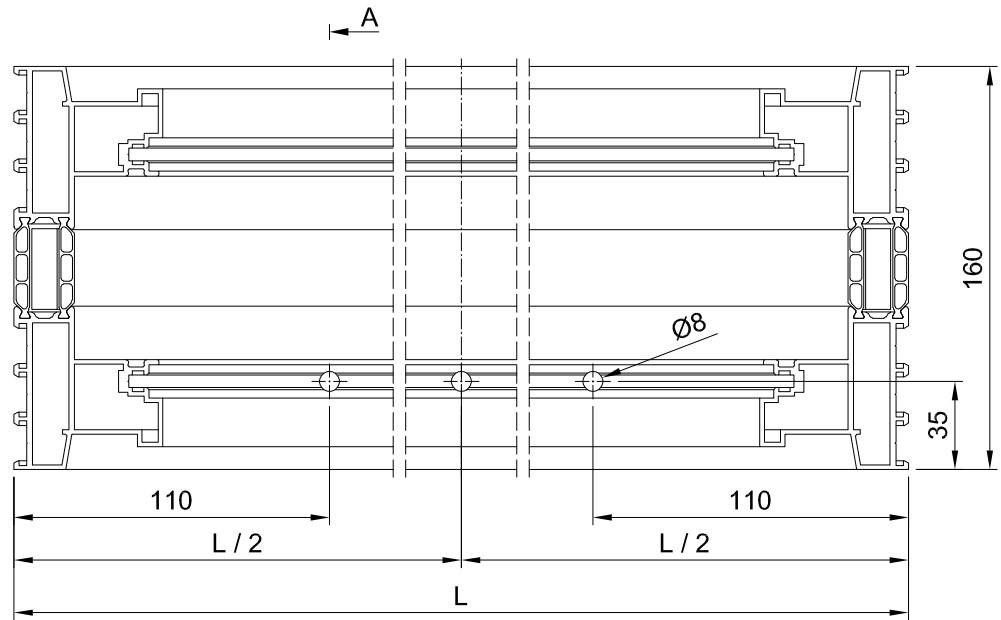
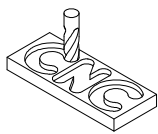
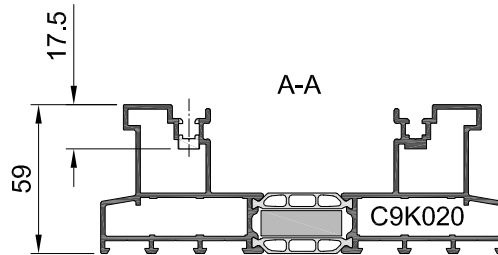
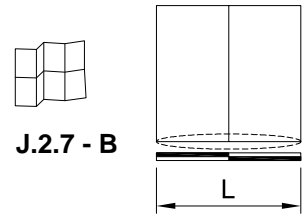

**C9K020 LAVORAZIONE DRENAGGIO - A**

6 / 11

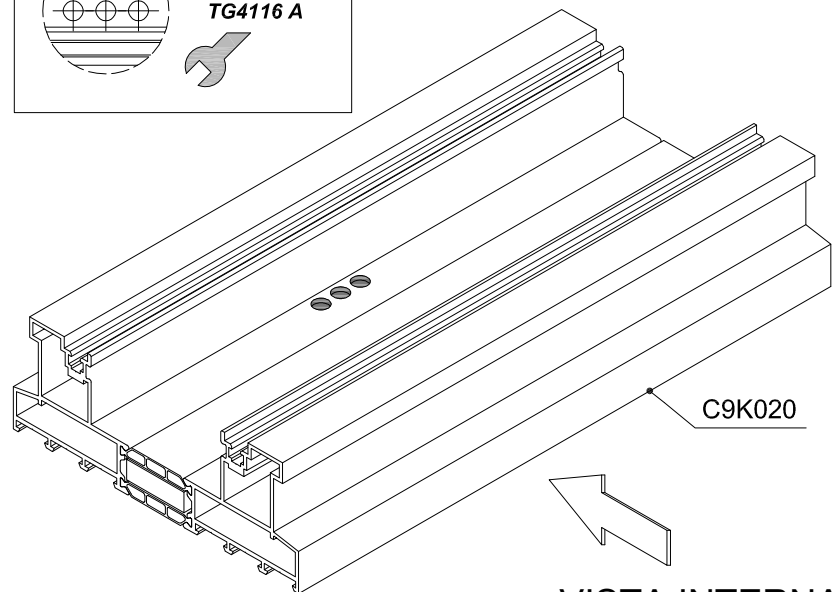
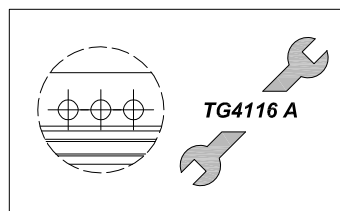
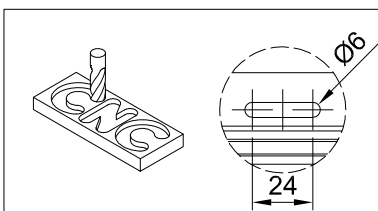
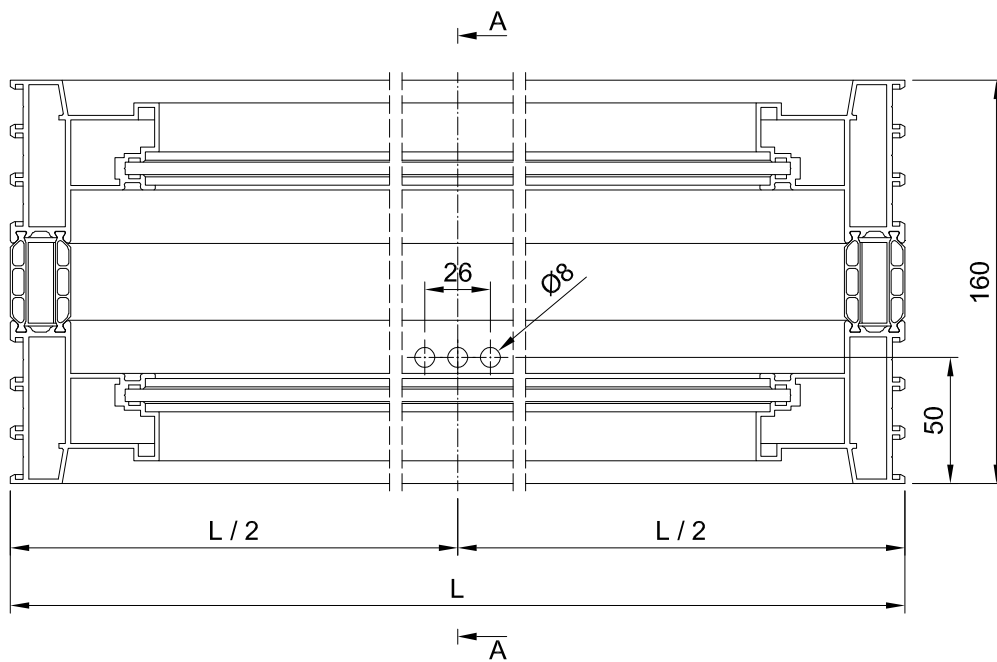
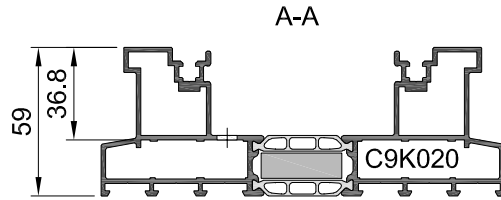
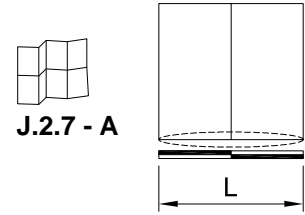

2-BINARI TELAIO TAGLI 45°

C9K020 LAVORAZIONE DRENAGGIO - G

7 / 11

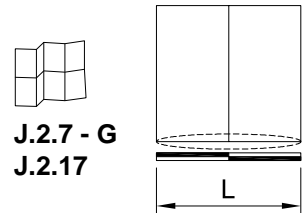

J.2.7 - G  
J.2.17

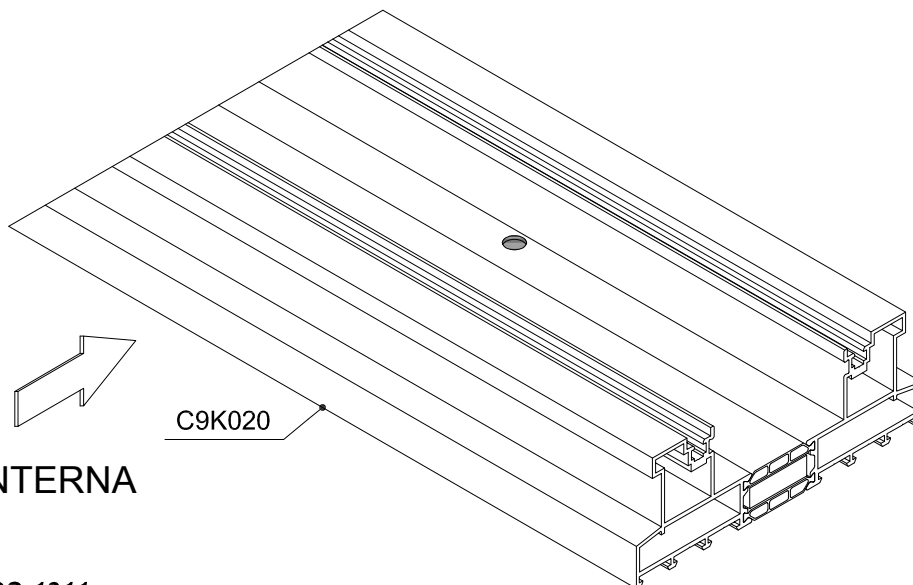
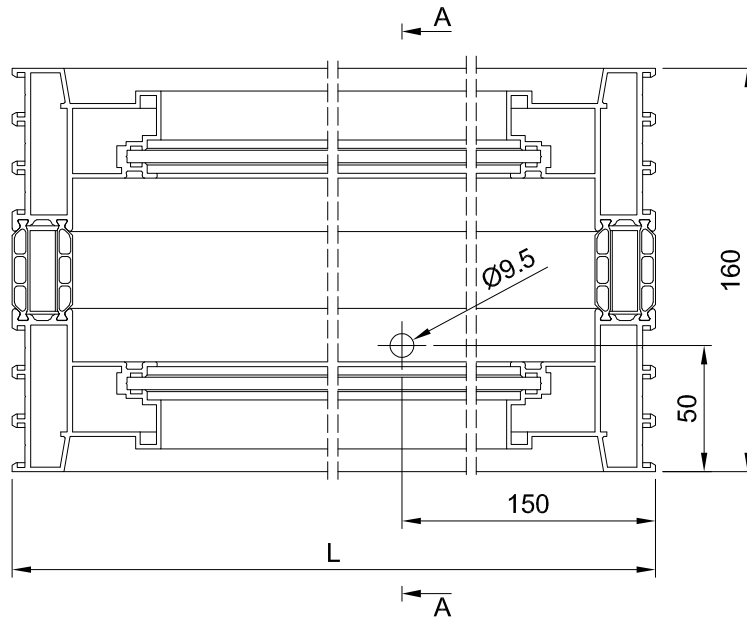
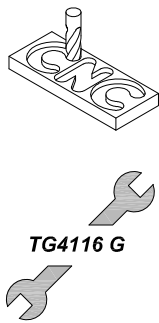
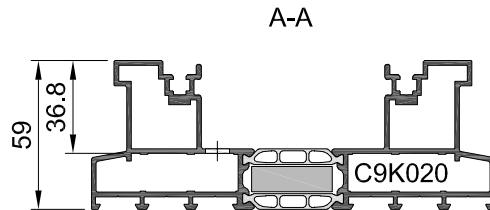

VISTA INTERNA

C160-ASS-1311

**C9K020 LAVORAZIONE DRENAGGIO - M**

8 / 11

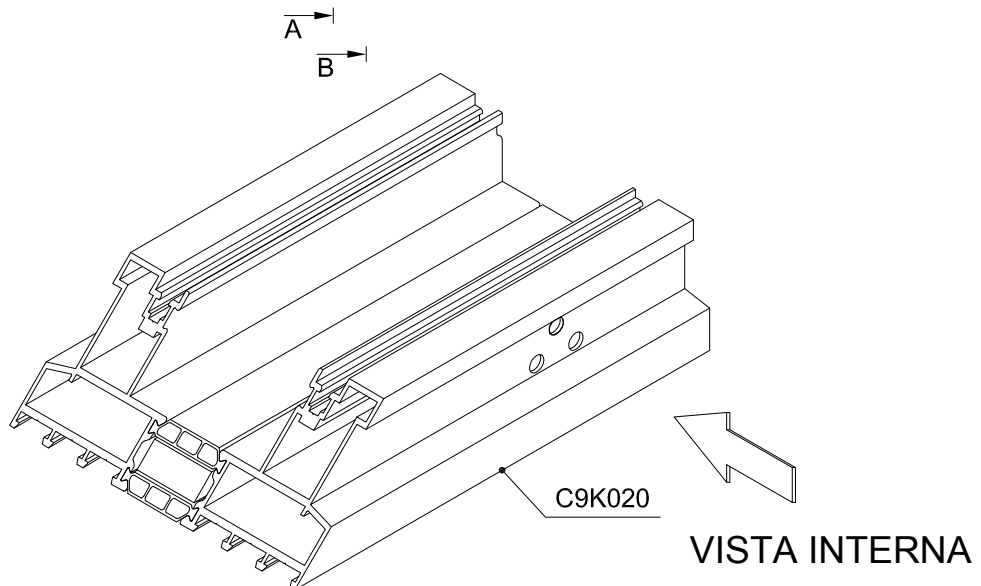
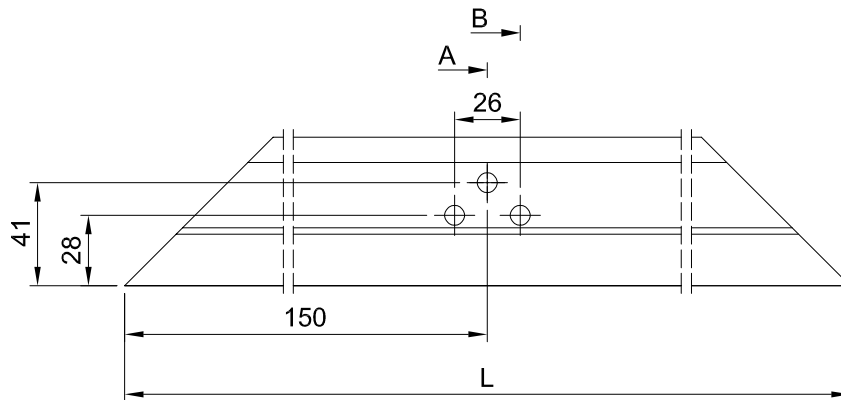
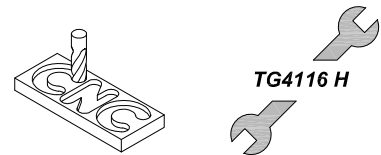
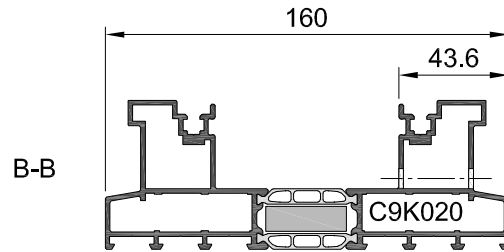
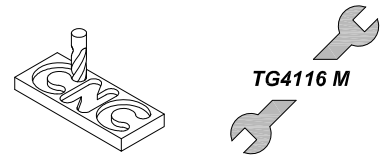
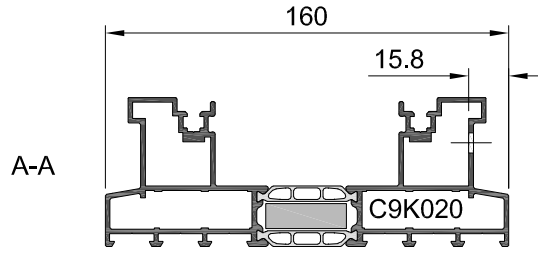
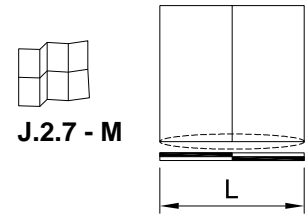



KU2028 LAVORAZIONE DRENAGGIO - K1

9 / 11



J.2.7 - K1  
X → J.1.4

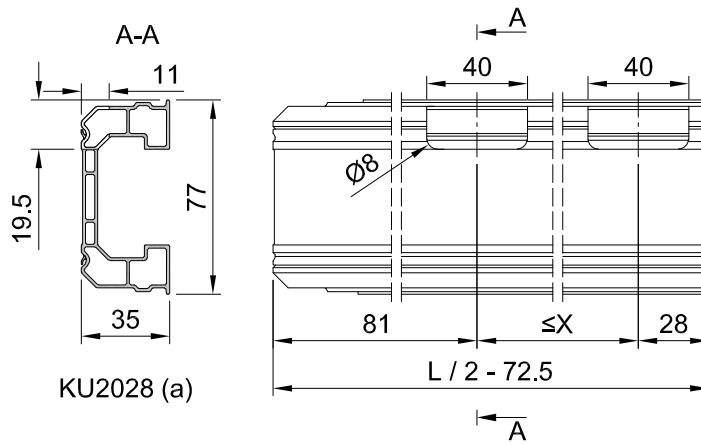
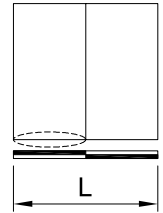

KU2028 (a)

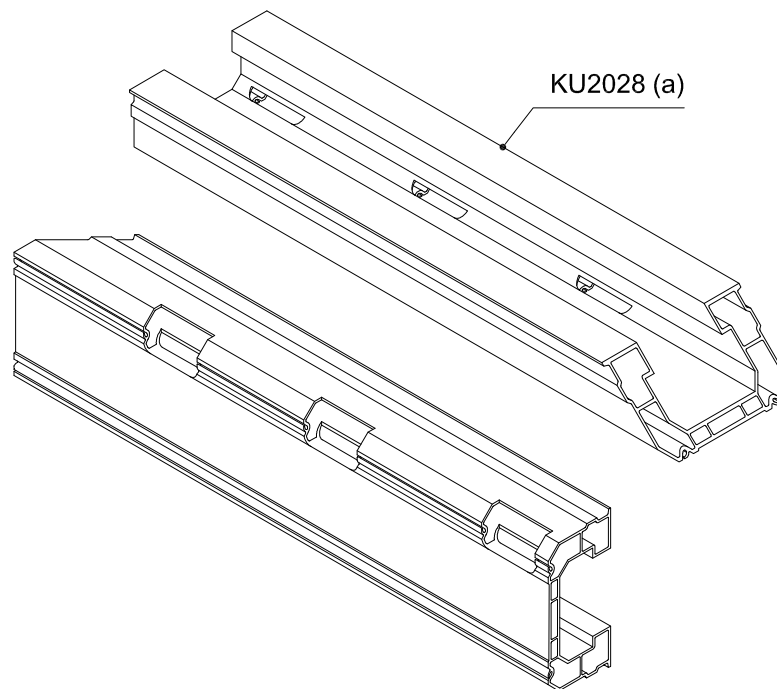

**KU2028 LAVORAZIONE DRENAGGIO - K2**

10 / 11

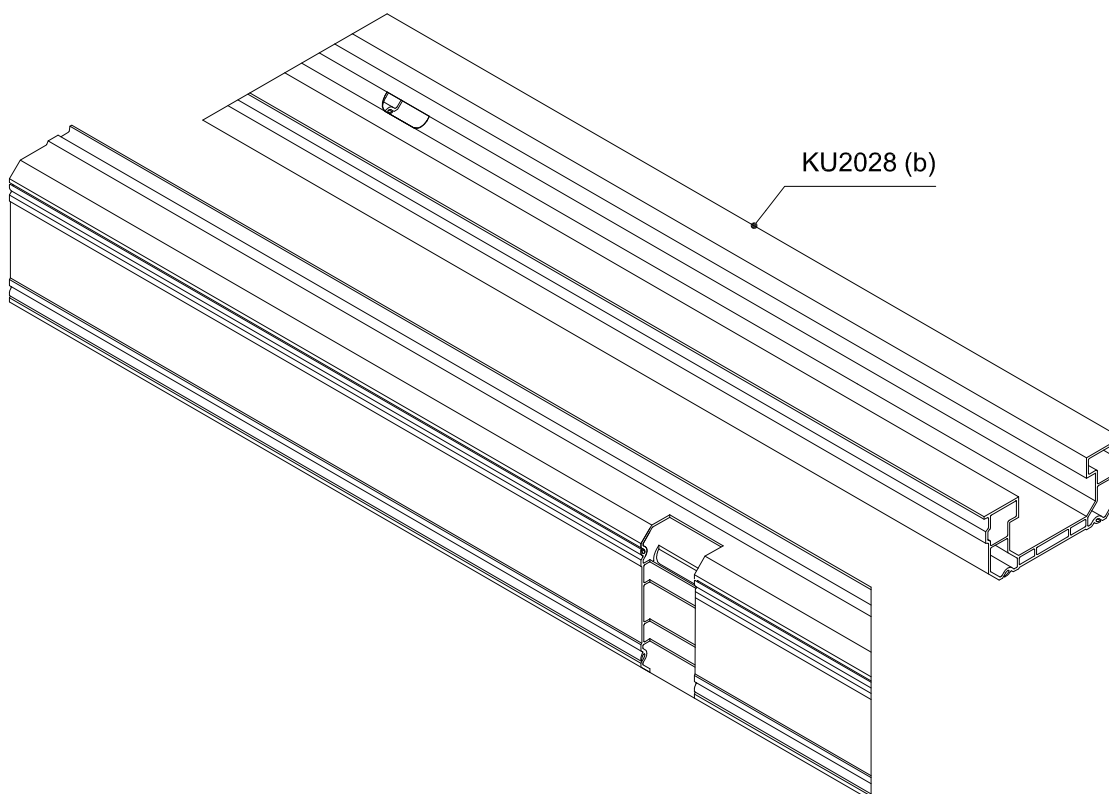
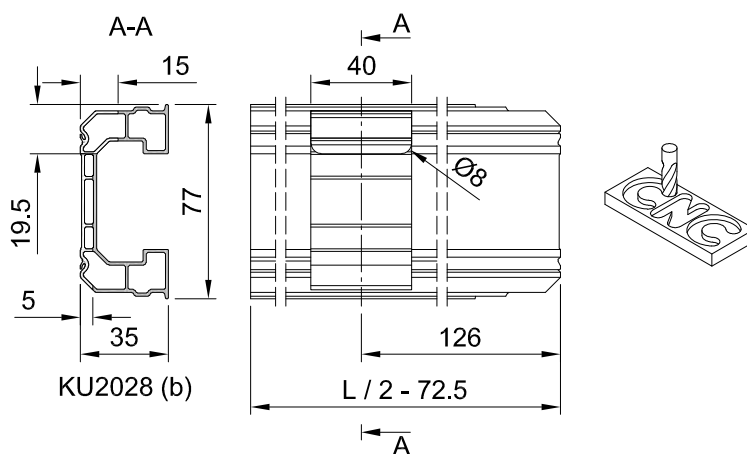
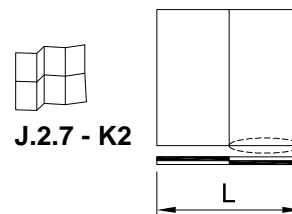

### ASSEMBLAGGIO VS0107 E KU2028 SU C9K020 PROFILATO INFERIORE C9K020

11 / 11

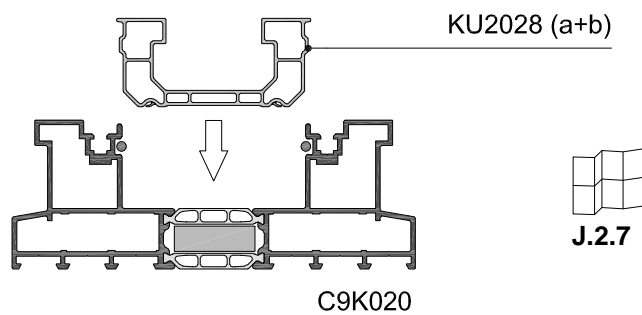
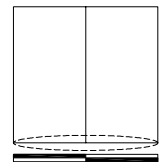
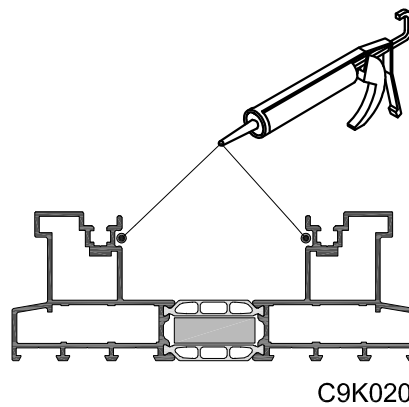
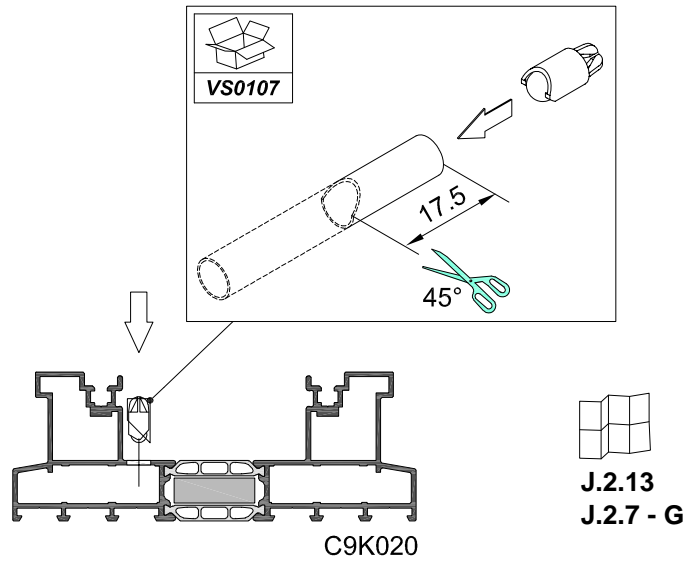
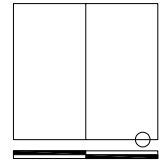

**ASSEMBLAGGIO TAPPO CENTRALE CO1105 PROFILATO INFERIORE C9K020**

1 / 2

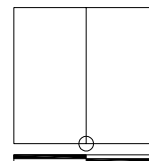

J.2.2 - D  
J.2.35

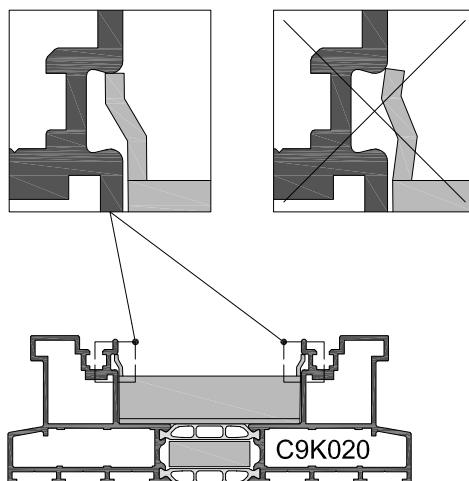
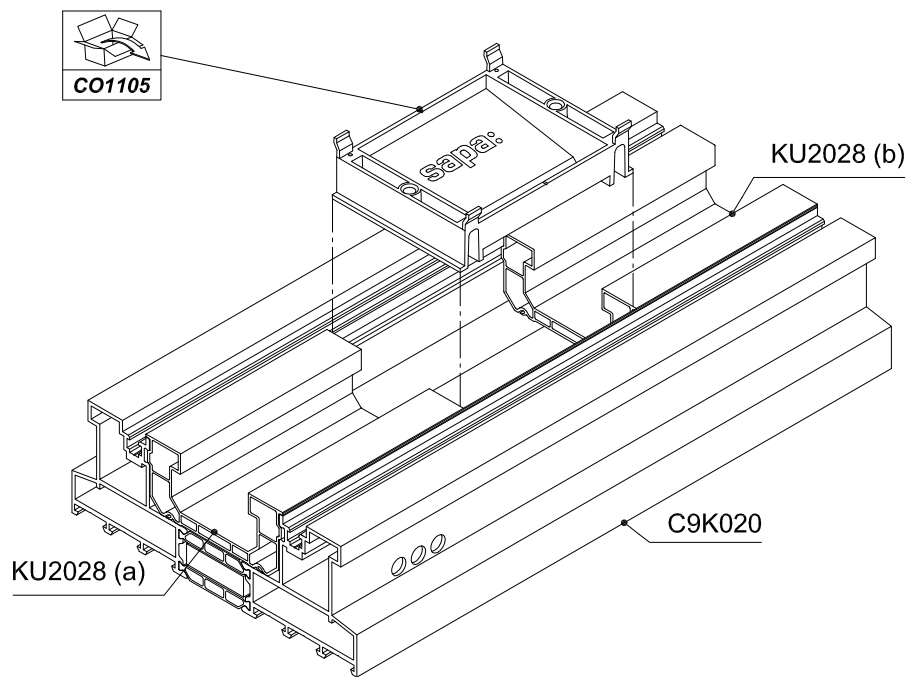

ASSEMBLAGGIO TAPPO CENTRALE CO1105/CO1104 PROFILATO INFERIORE C9K020

2 / 2



J.2.2 - D  
J.2.35

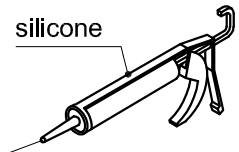
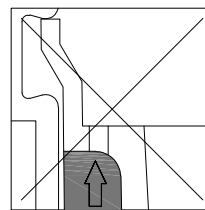
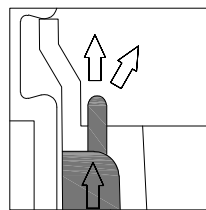
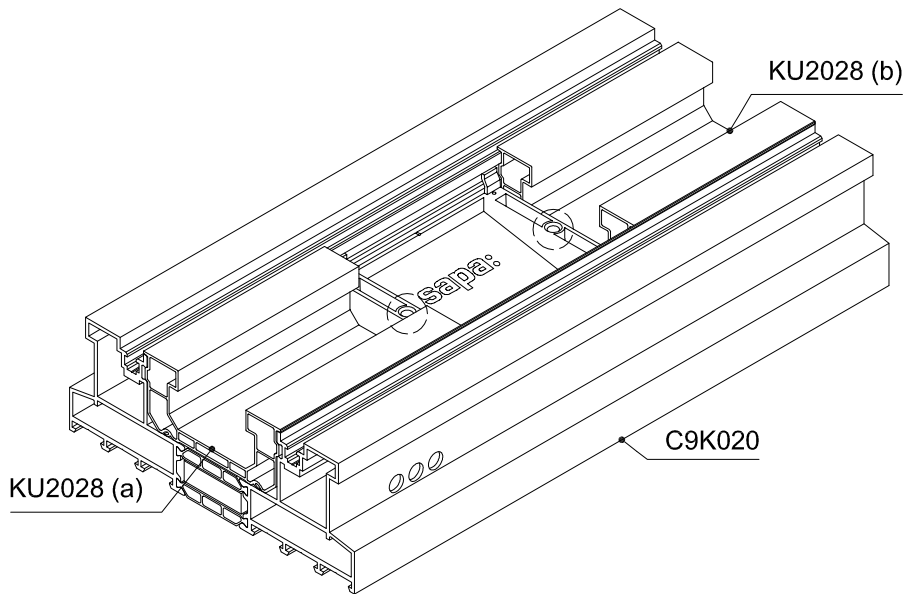
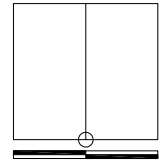

silicone

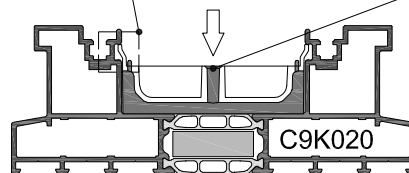

**SIGILLATURA PROFILATO INFERIORE C9K020 CON VS9950 E VS9951**

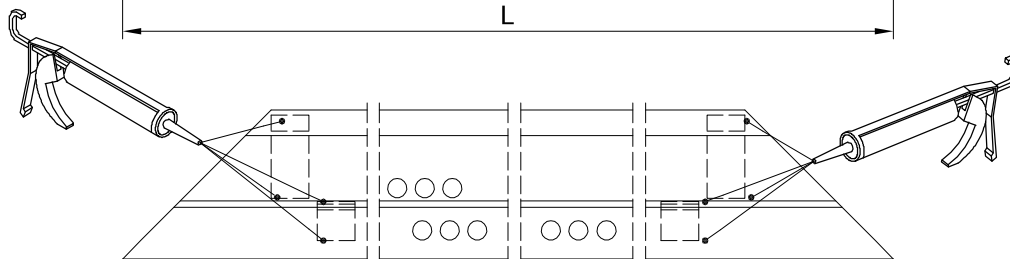
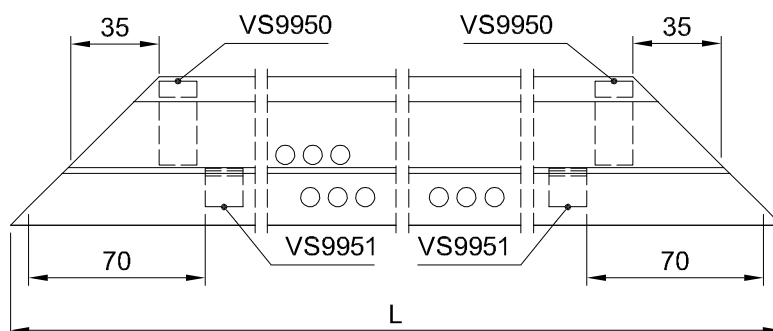
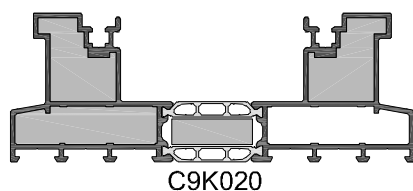
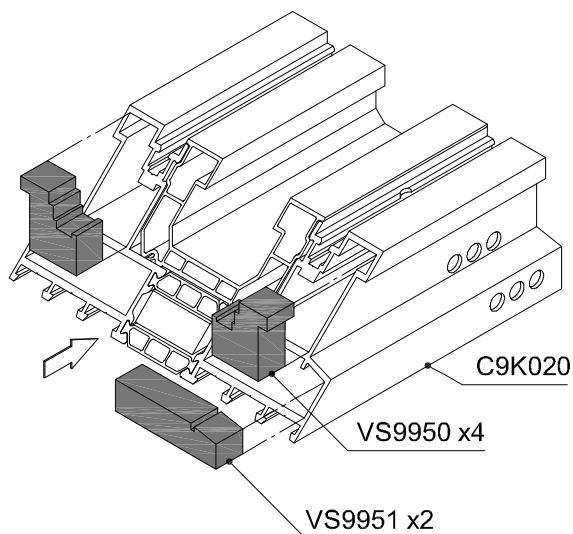
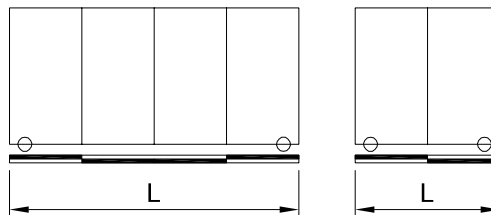

ASSEMBLAGGIO TAPPO CENTRALE CO1111 PROFILATO SUPERIORE C9K020

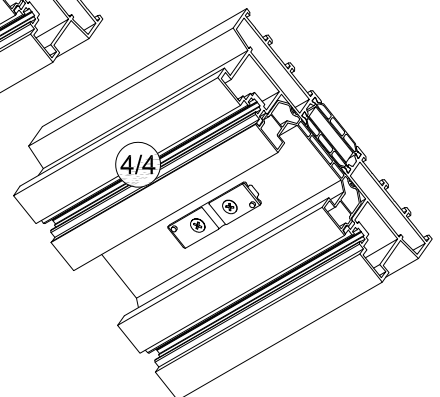
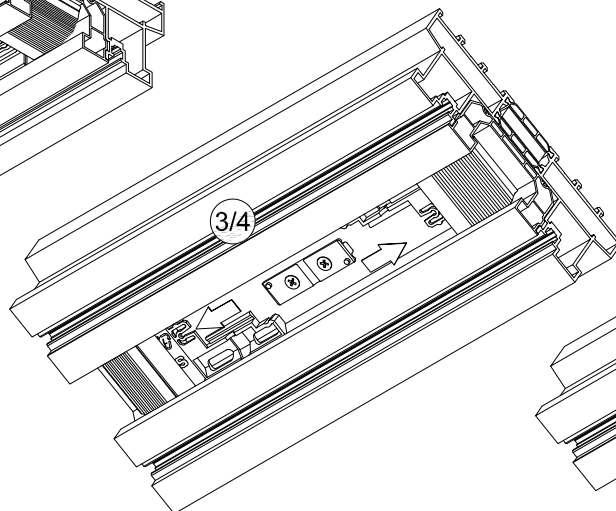
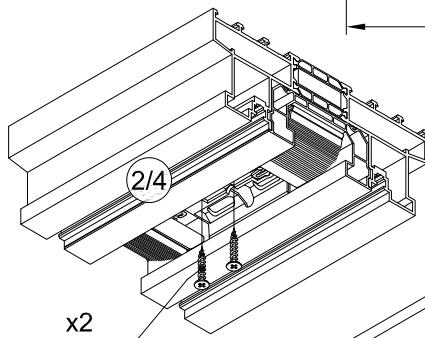
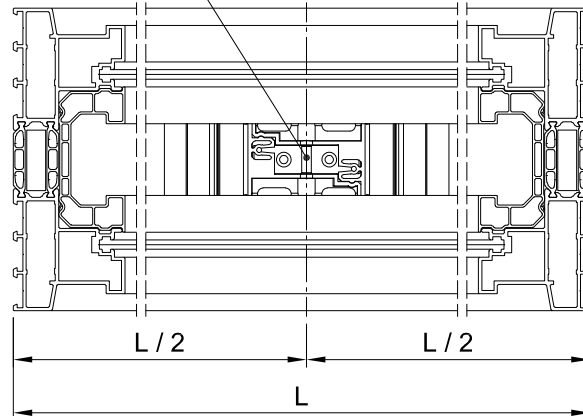
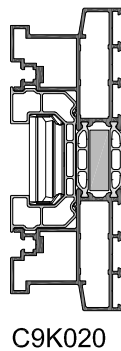
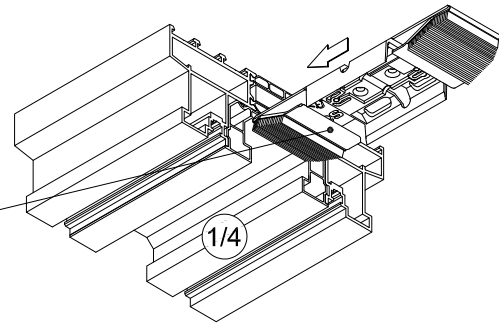
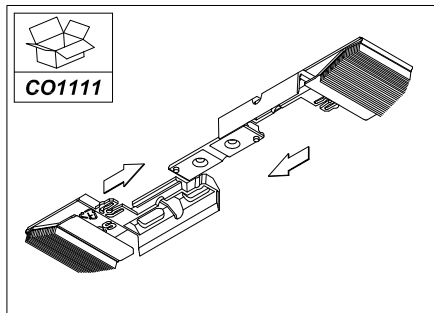
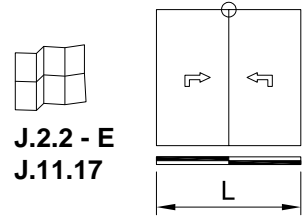

C160-ASS-1302

**ASSEMBLAGGIO PUNTI DI CHIUSURA - ZB0034/ZB0035/ZB0036**

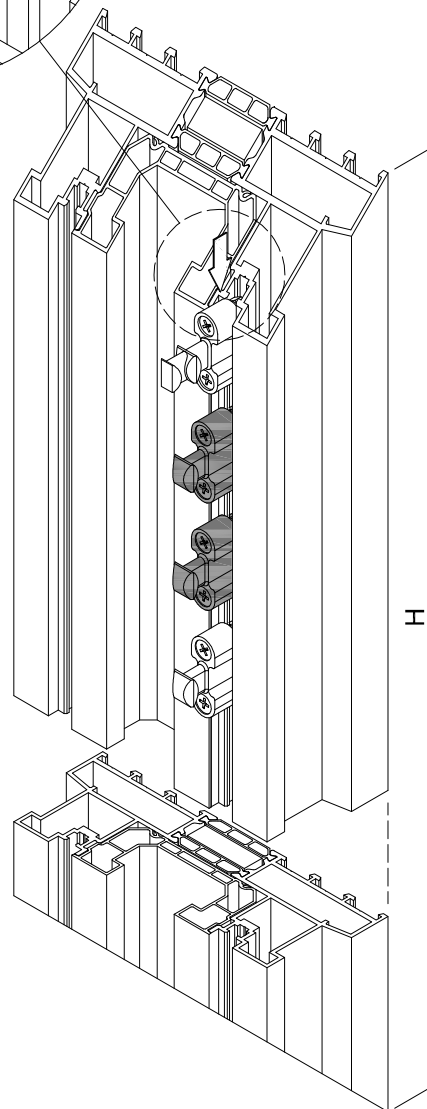
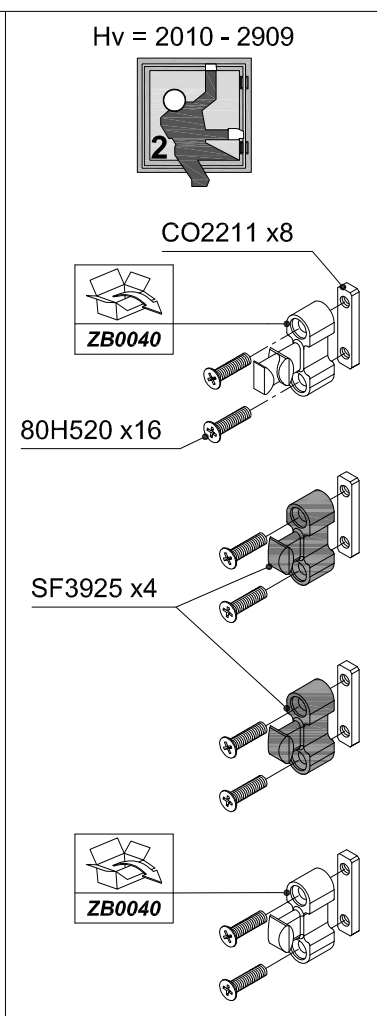
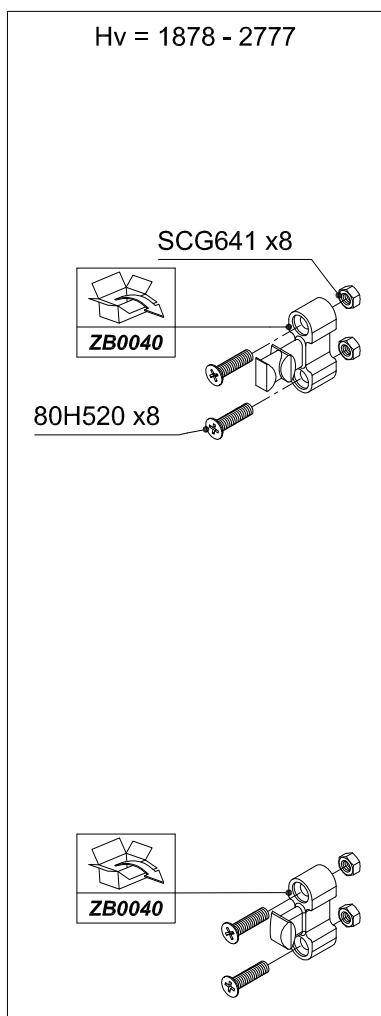
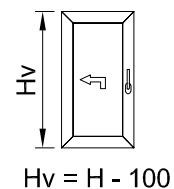
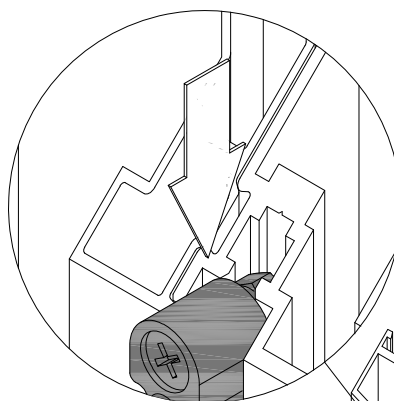
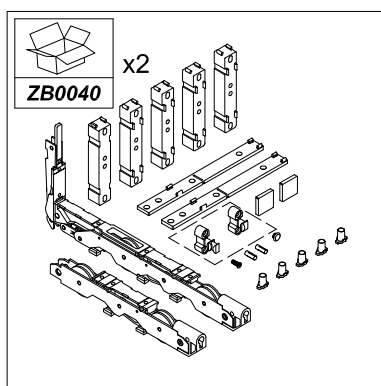
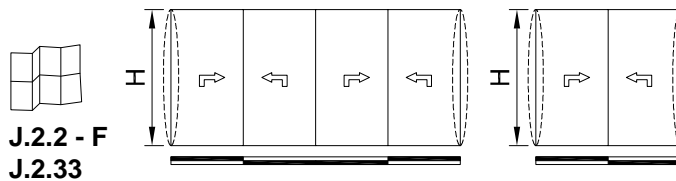



## 2-BINARI TELAIO TAGLI 45°

### ASSEMBLAGGIO PROFILATI TELAI CON SQUADRETTE

1 / 3



J.2.2 - A  
J.2.5

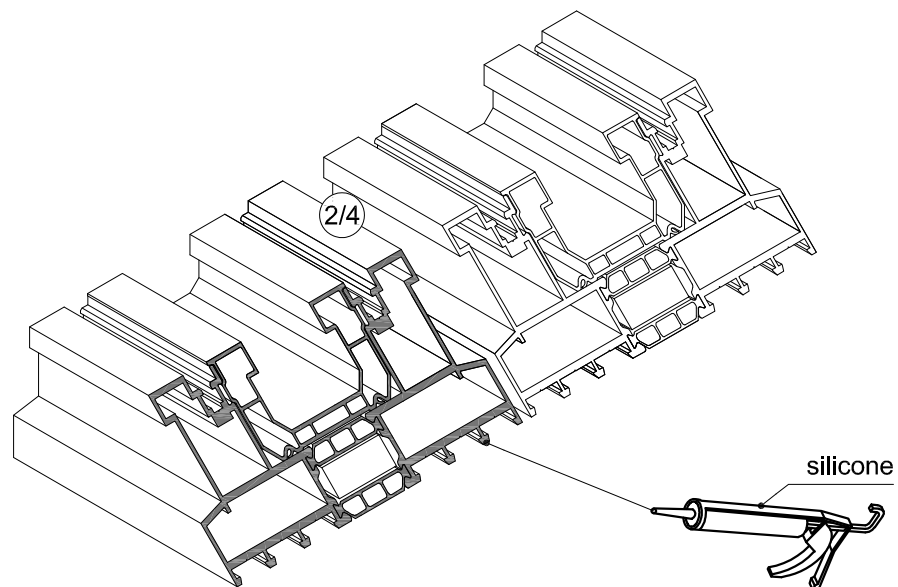
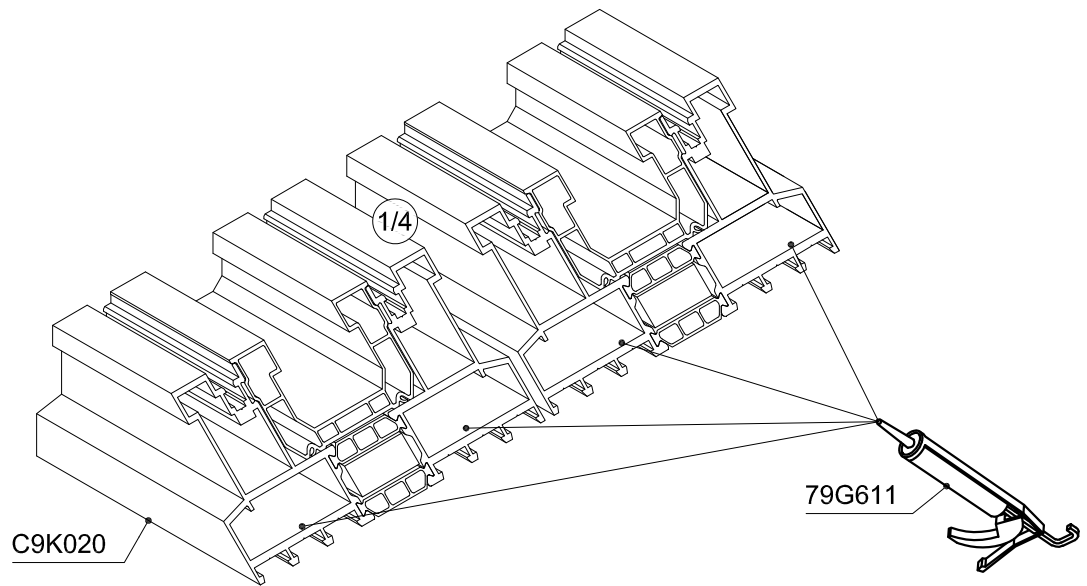
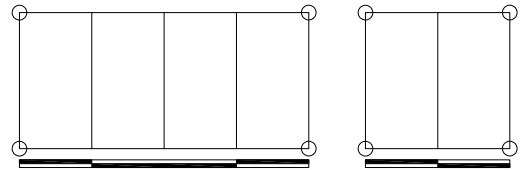

**ASSEMBLAGGIO PROFILATI TELAI CON SQUADRETTE**

2 / 3



J.2.2 - A  
J.2.5

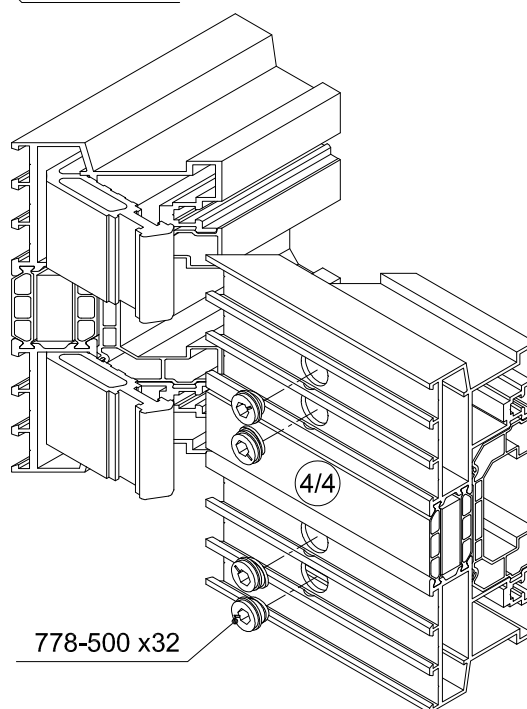
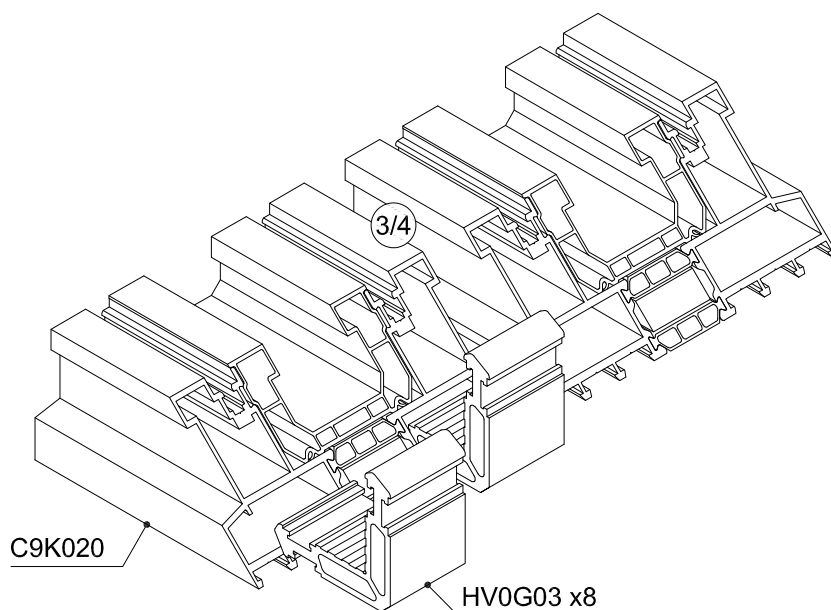
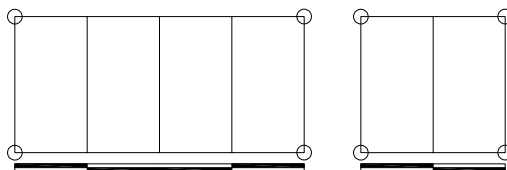

## 2-BINARI TELAIO TAGLI 45°

### ASSEMBLAGGIO PROFILATI TELAI CON SQUADRETTE

3 / 3



J.2.2 - A  
J.2.5

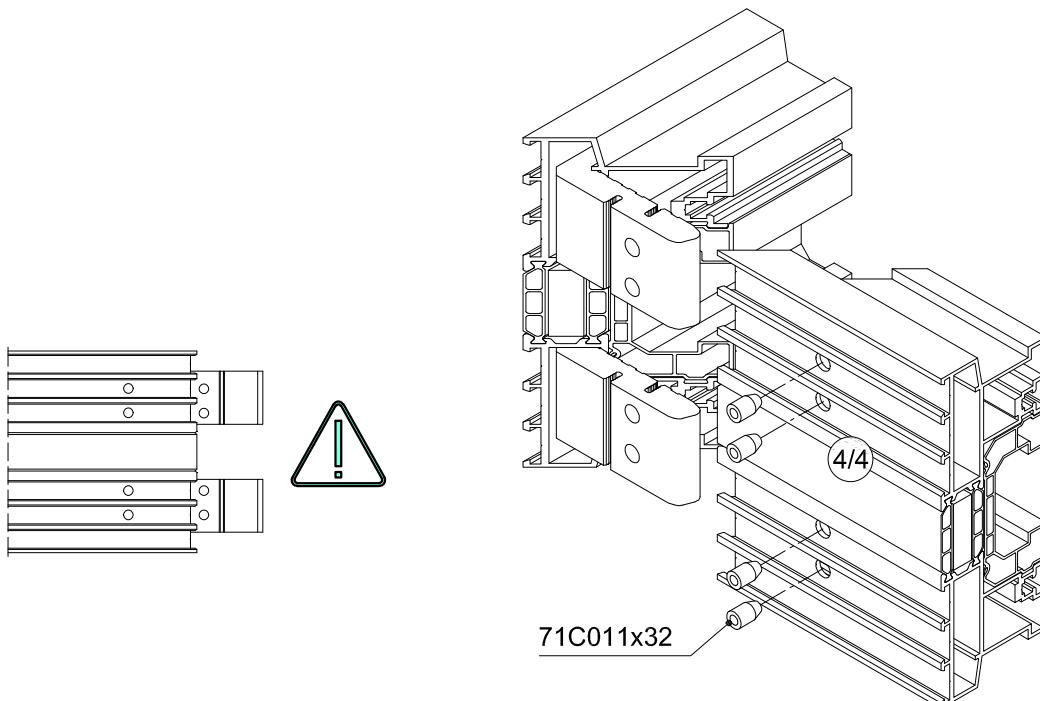
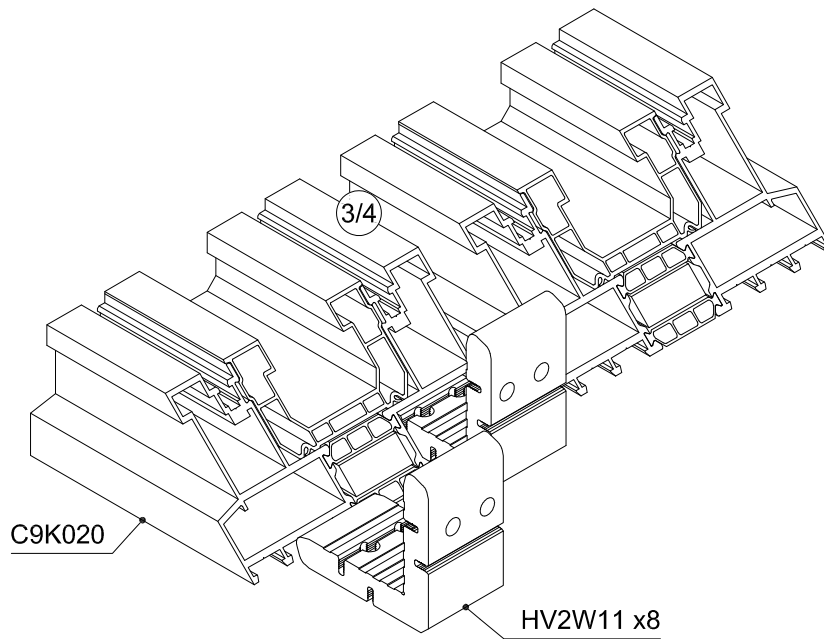
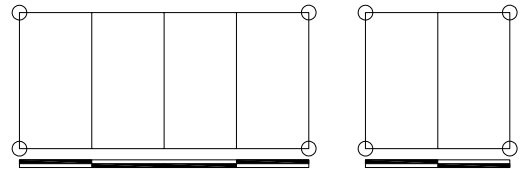

**ASSEMBLAGGIO CAPPETTA DI DRENAGGIO C9A003**



J.2.2 - B  
 J.2.6

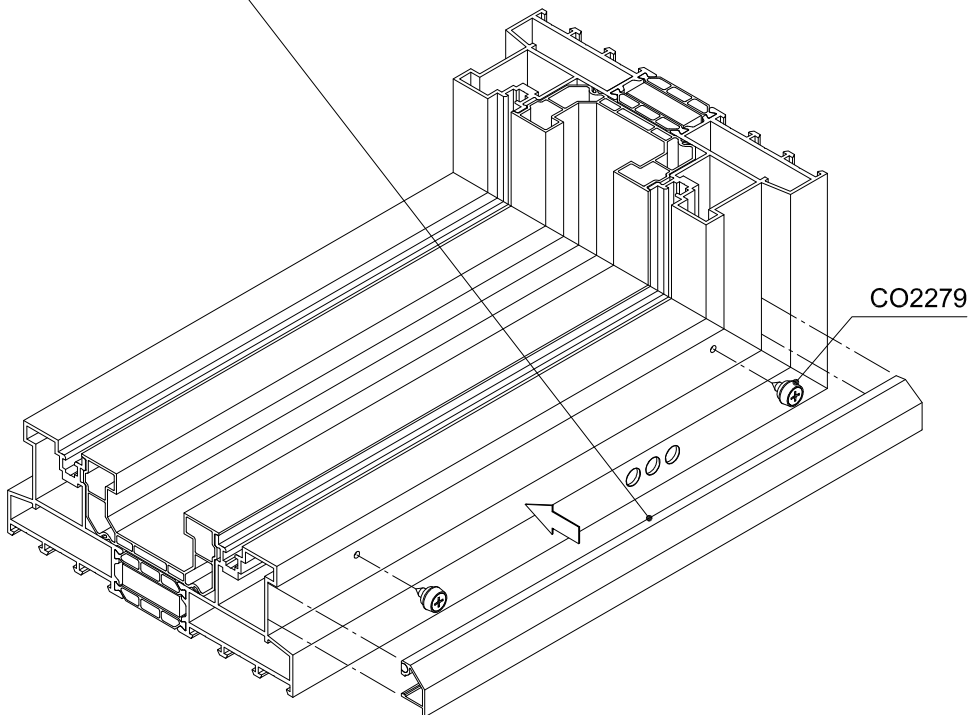
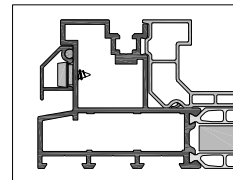
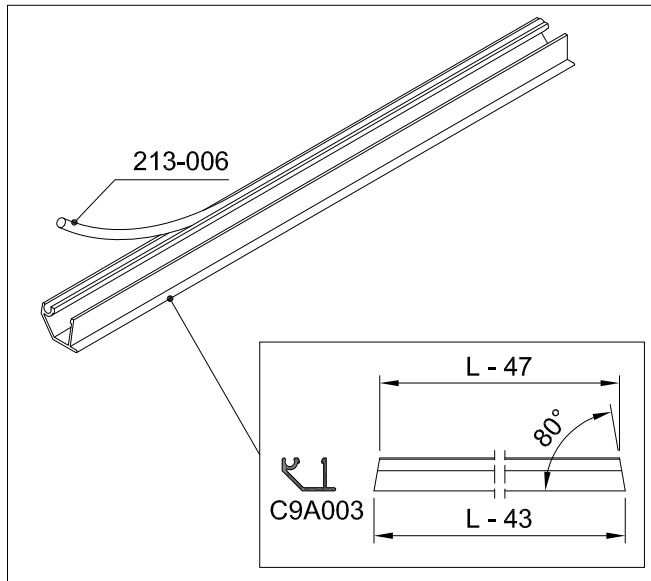
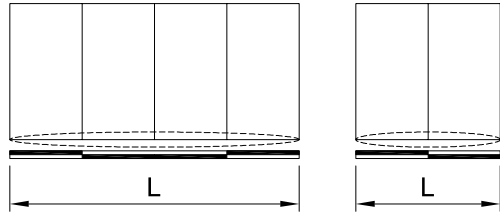

## 2-BINARI TELAIO TAGLI 45°

### OPERAZIONI C9A004 + VS2404

1 / 3

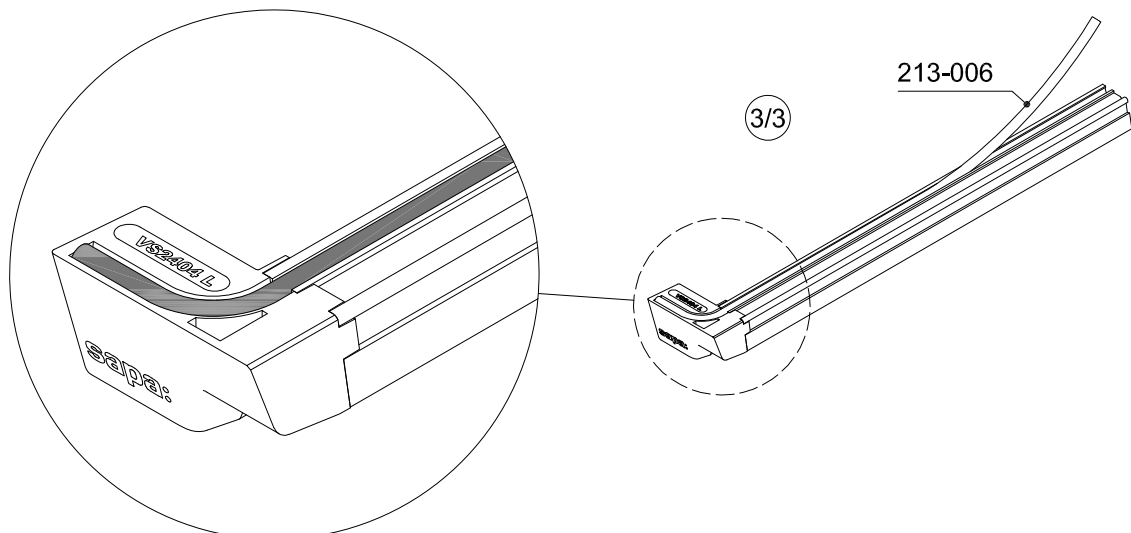
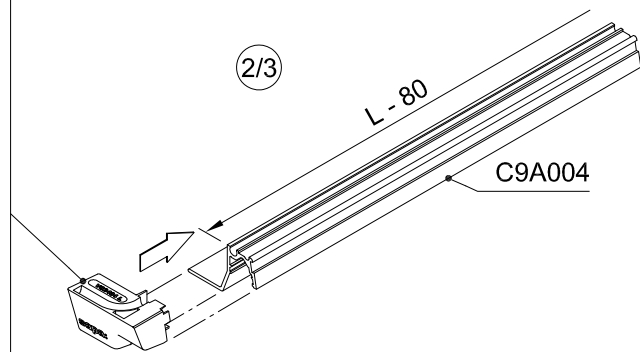
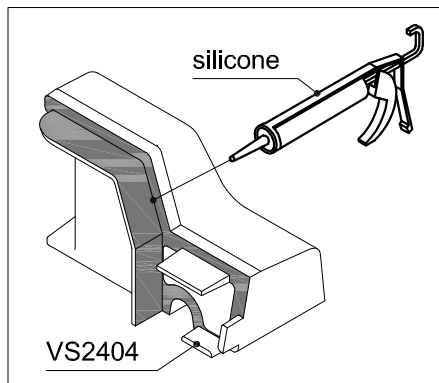
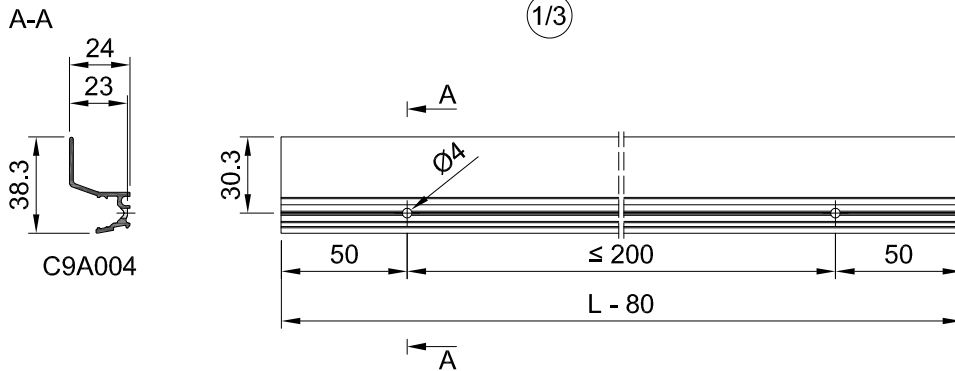
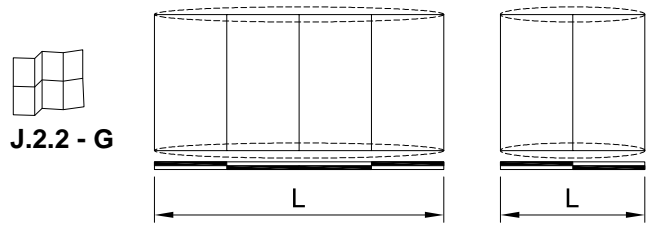

**ASSEMBLAGGIO C9A004 + VS2404**

2 / 3

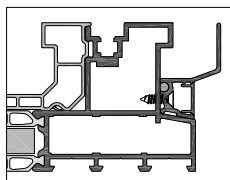
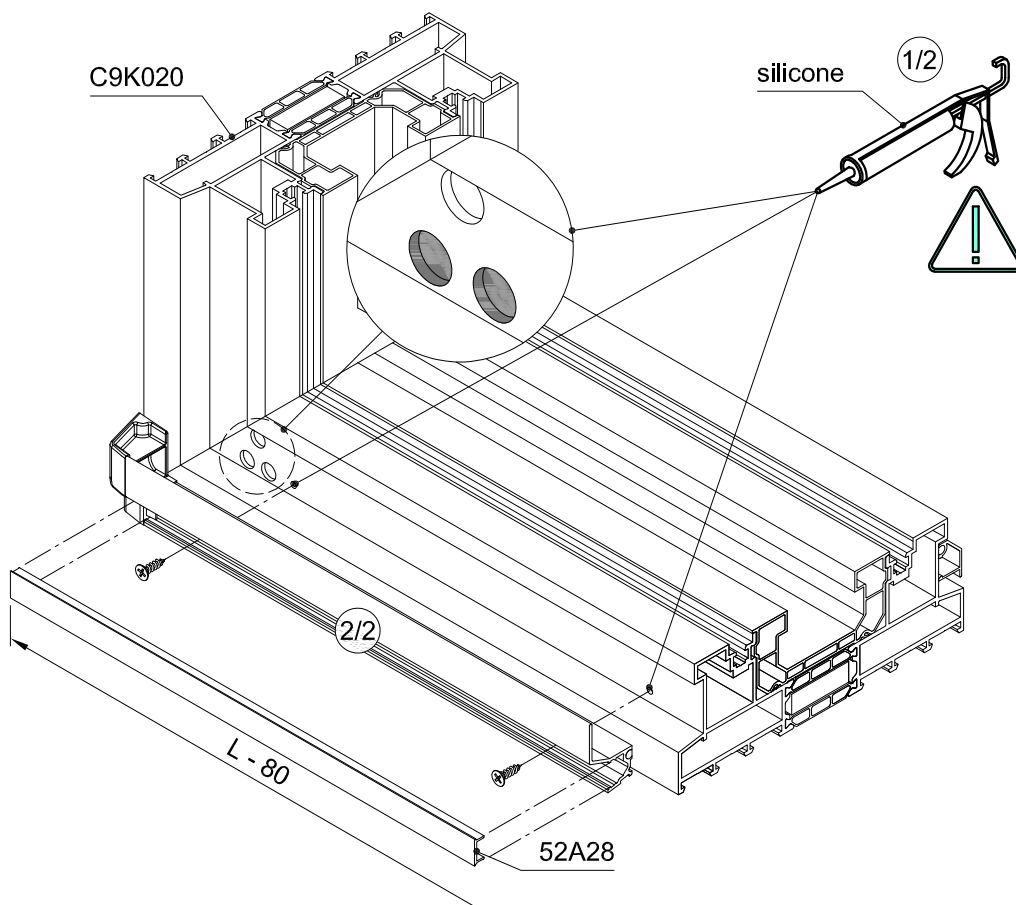
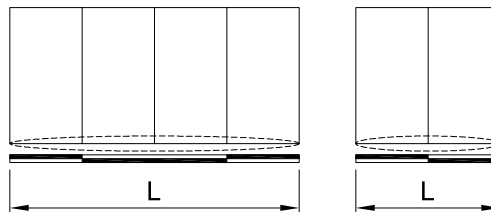
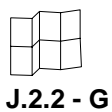

ASSEMBLAGGIO C9A004 + VS2404 - OPTIONAL

3 / 3

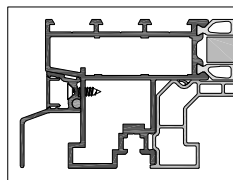
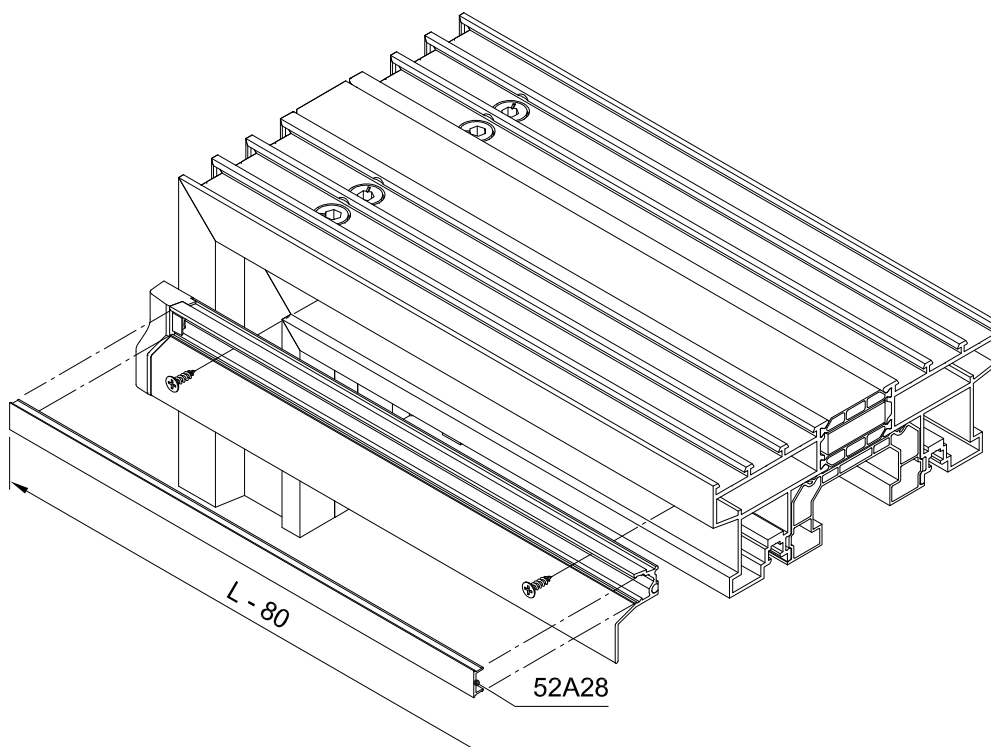
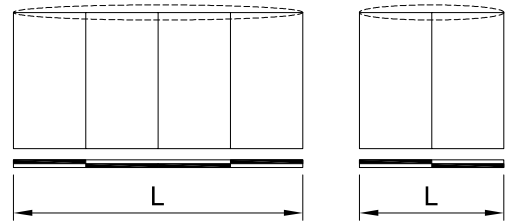

**ASSEMBLAGGIO CO1103**

1 / 3

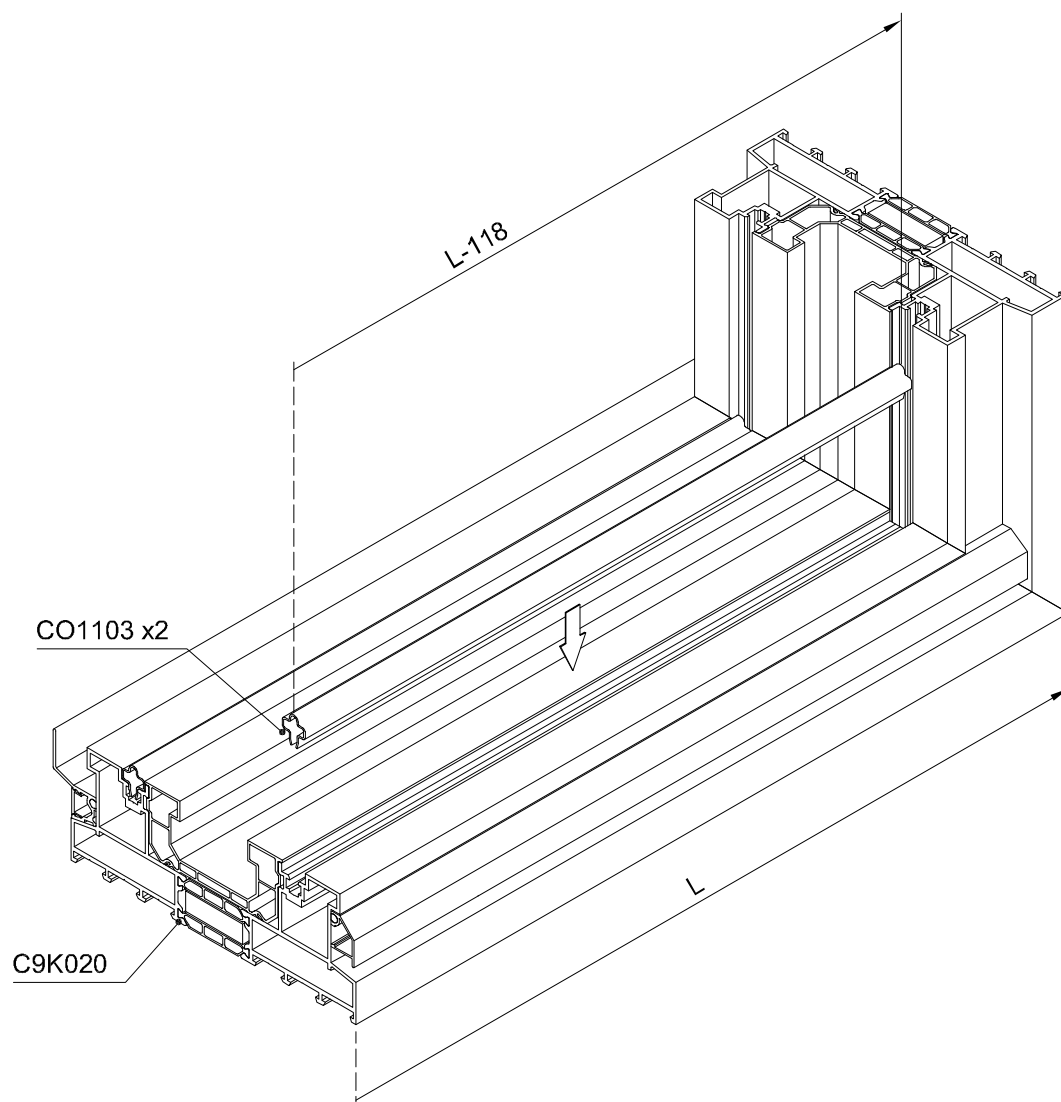
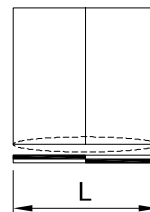



ASSEMBLAGGIO CO1103 CON 1 ANTA FUNZIONALE

2 / 3

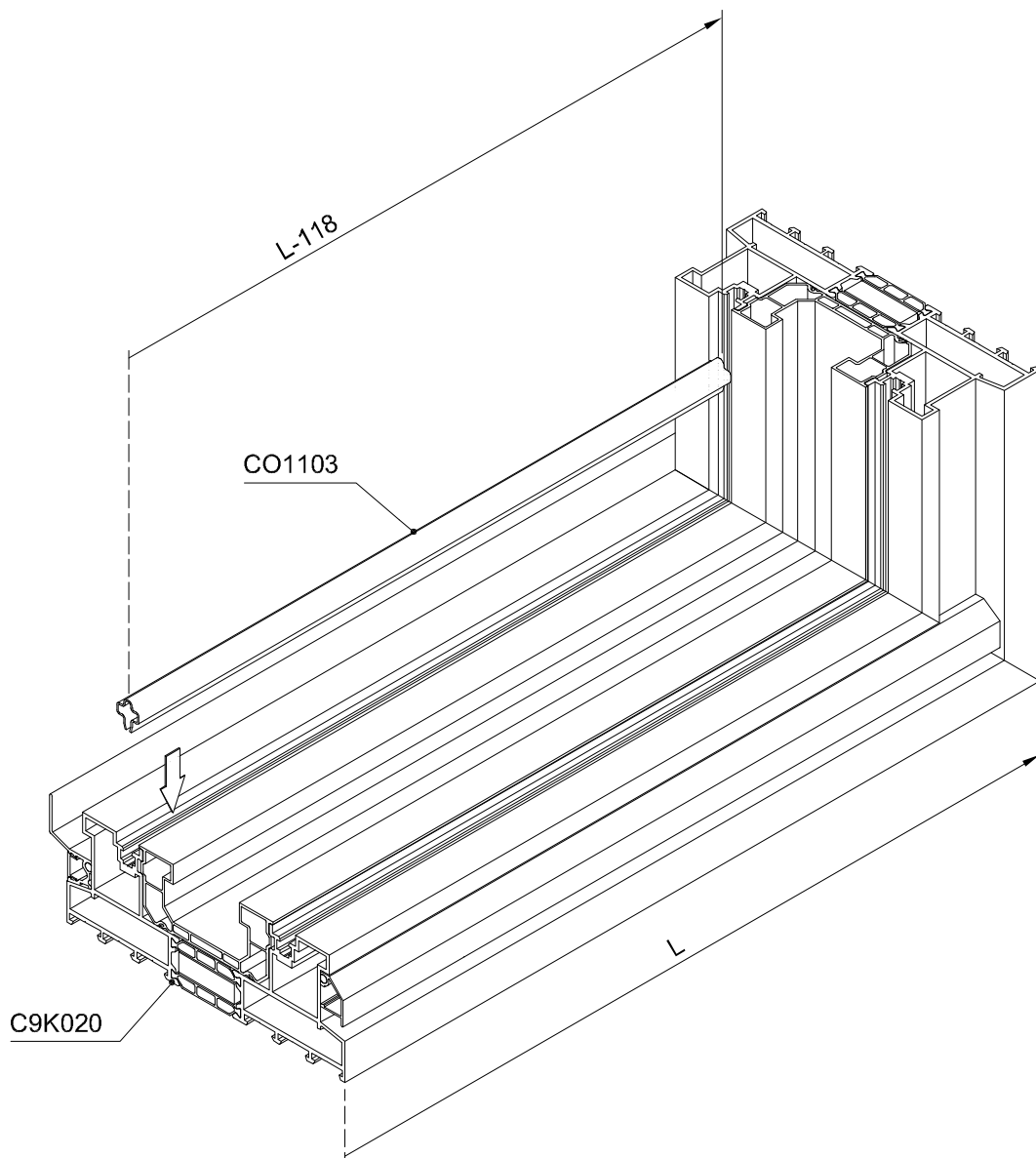
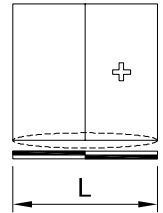

**ASSEMBLAGGIO CO1103 E ZB0038 PER SCHEMA 4 ANTE**

3 / 3

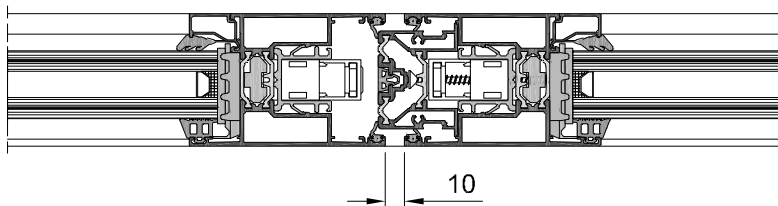
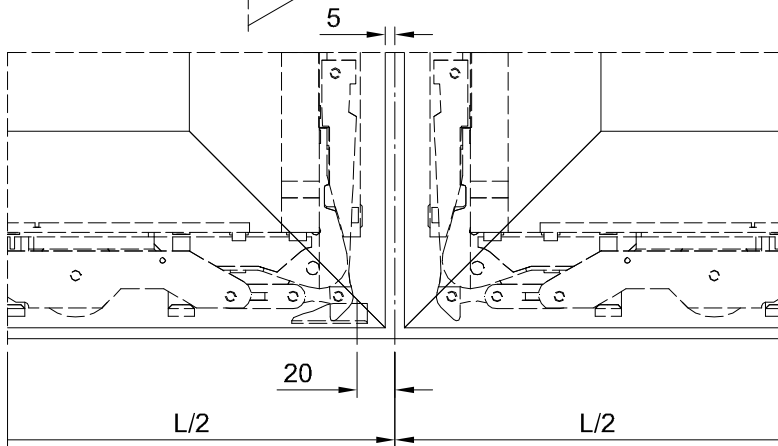
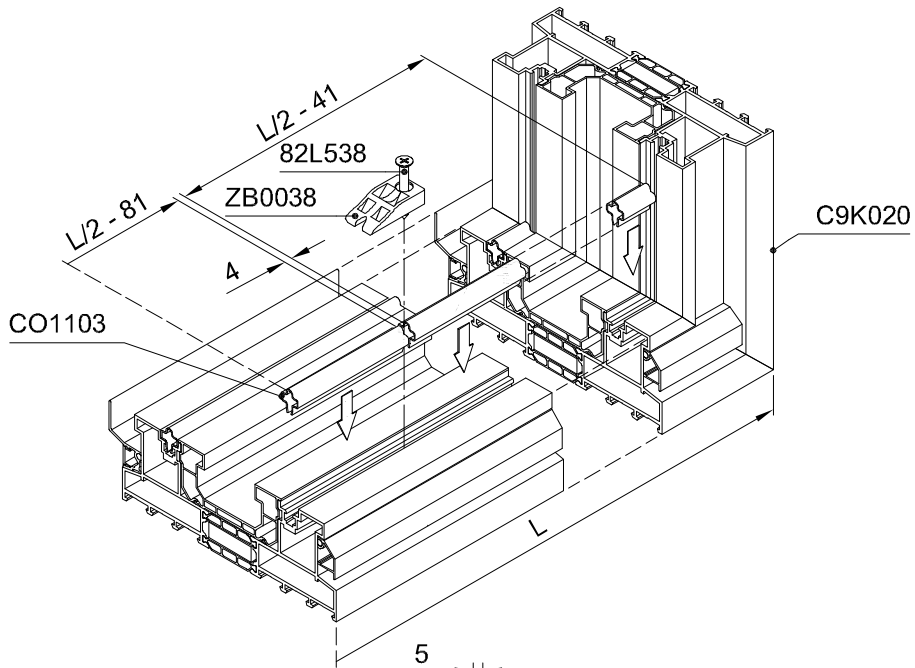
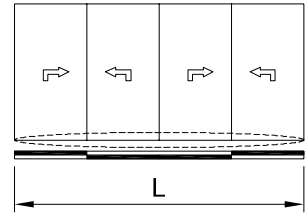

## 2-BINARI TELAIO TAGLI 45°

### ASSEMBLAGGIO PUNTI DI CHIUSURA

1 / 2

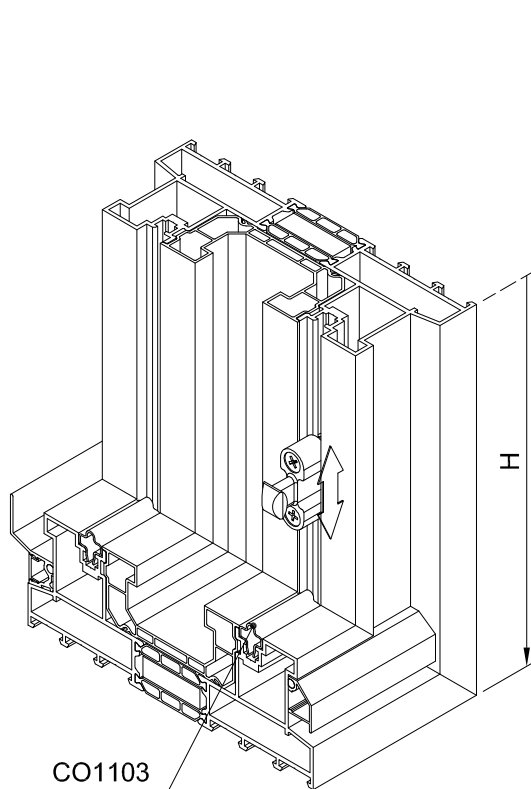
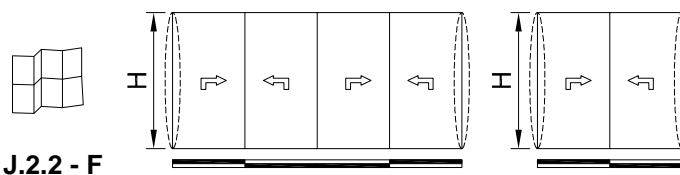

CO1103

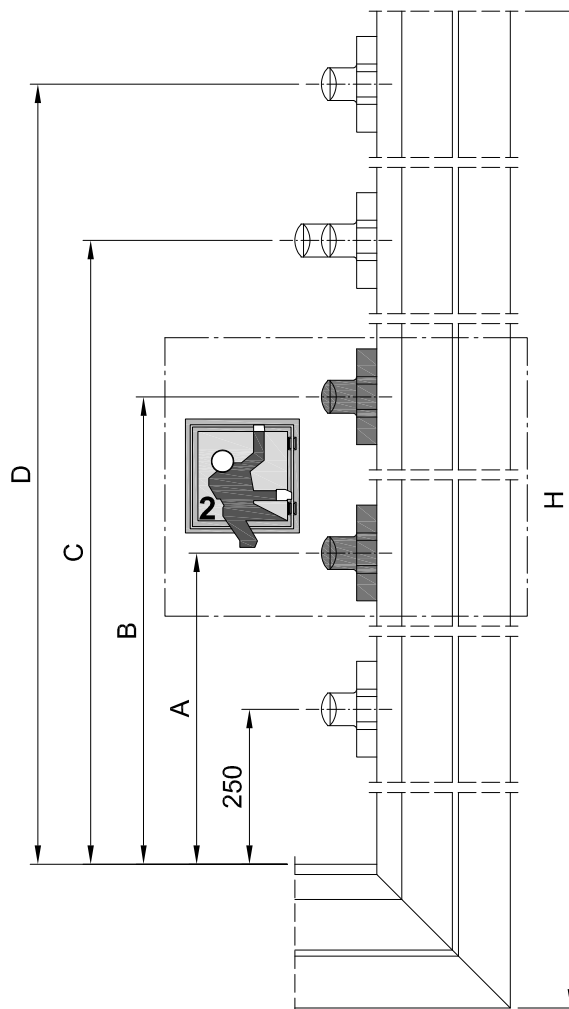

	Hv						
				A	B	C	D
	1180 - 1877	1312 - 2009	ZB0033	-	600	1000	-
	1878 - 2177	2010 - 2309	ZB0034	750	1200	1600	
	2178 - 2477	2310 - 2609	ZB0035			1900	
	2478 - 2777	2610 - 2909	ZB0036			2200	
	2778 - 3077	2910 - 3209	ZB0035 + ZB0046			750	1200
	3078 - 3377	3210 - 3509	ZB0036 + ZB0046	2200			

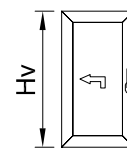

$Hv = H - 100$

**ASSEMBLAGGIO GUARNIZIONE DI FINITURA RU9704**

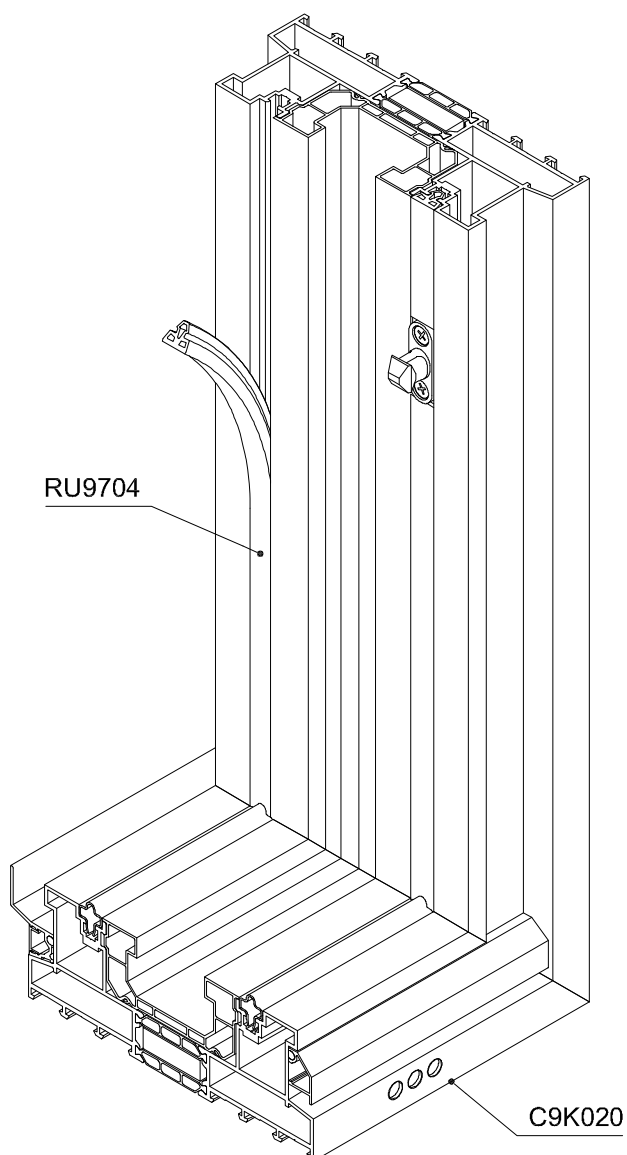
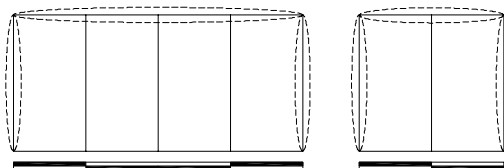





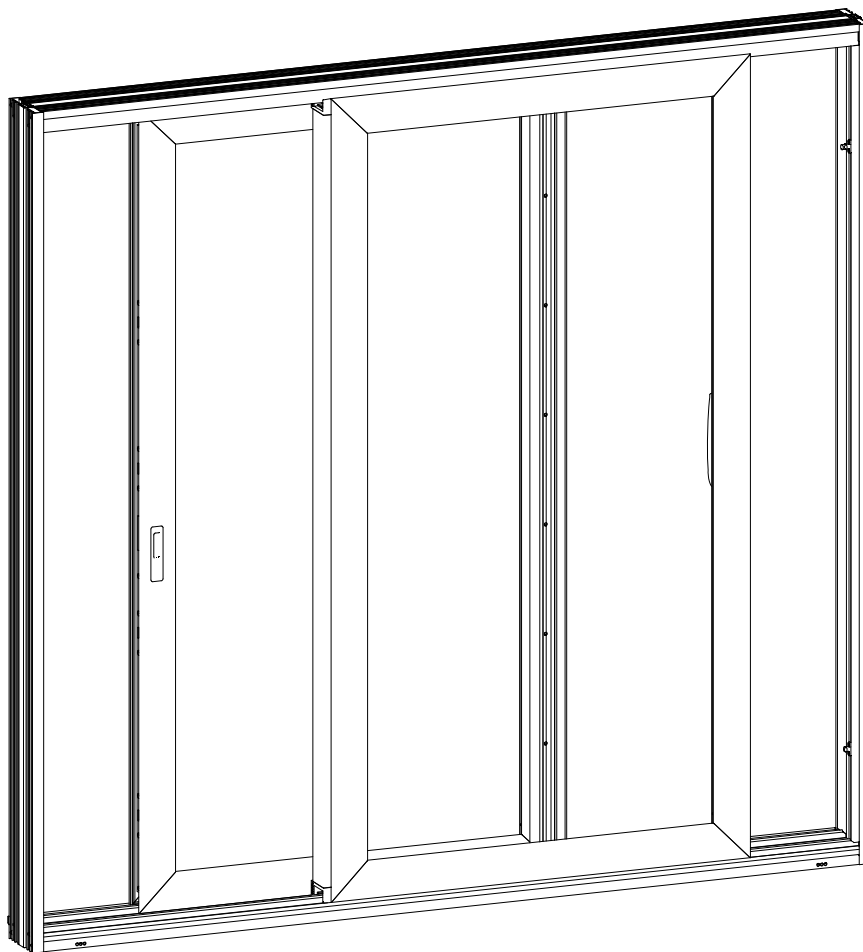

PANORAMICA ASSEMBLAGGIO

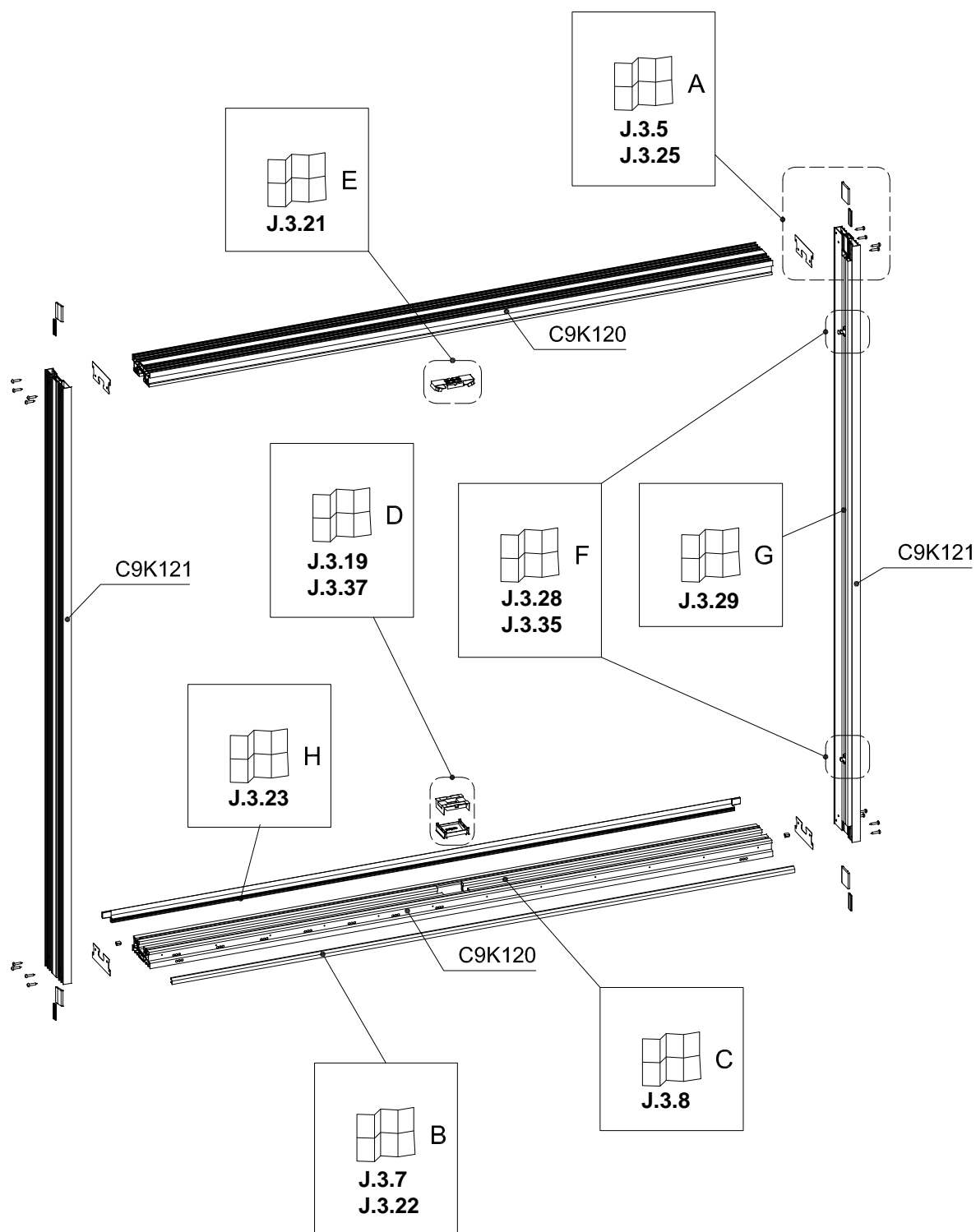



### CONTENUTO

2-binari telaio tagli 90° .....	J.3.1
Panoramica assemblaggio .....	J.3.2
Contenuto .....	J.3.3



Operazioni C9K121 e assemblaggio BT6019 .....	J.3.4
Operazioni C9K121 per assemblaggio telaio .....	J.3.5
Operazioni C9K120 + KU2028 e assemblaggio BT6006 .....	J.3.6



Operazioni C9K120 per cappetta di drenaggio .....	J.3.7
C9K120 e KU2028 panoramica drenaggi .....	J.3.8
C9K120 lavorazione drenaggio - J (optional 1/2) .....	J.3.9
C9K120 lavorazione drenaggio - H .....	J.3.11
C9K120 lavorazione drenaggio - B .....	J.3.12
C9K120 lavorazione drenaggio - A .....	J.3.13
C9K120 lavorazione drenaggio - G .....	J.3.14
C9K120 lavorazione drenaggio - M .....	J.3.15
KU2028 lavorazione drenaggio - K1 .....	J.3.16
KU2028 lavorazione drenaggio - K2 .....	J.3.17



Assemblaggio VS0107 e KU2028 su C9K020 profilato inferiore C9K120 .....	J.3.18
Assemblaggio tappo centrale CO1105 profilato inferiore C9K120 .....	J.3.19
Assemblaggio tappo centrale CO1111 profilato superiore C9K120 .....	J.3.21
Assemblaggio cappetta di drenaggio C9A003 .....	J.3.22
Operazioni C9A004 .....	J.3.23
Assemblaggio C9A004 .....	J.3.24
Assemblaggio CO0132 e VS9957 su C9K121 .....	J.3.25



Assemblaggio VS9999 su C9K121 e assemblaggio telaio .....	J.3.26
Sigillatura C9A004 .....	J.3.27
Assemblaggio punti di chiusura (ZB0034/ZB0035/ZB0036) .....	J.3.28
Assemblaggio RU9704 .....	J.3.29
Assemblaggio C9A100 .....	J.3.30
Assemblaggio KU2035 .....	J.3.31
Assemblaggio CO1103 .....	J.3.32
Assemblaggio CO1103 con 1 anta funzionale .....	J.3.33
Assemblaggio CO1103 e ZB0038 per schema 4 ante .....	J.3.34
Assemblaggio punti di chiusura .....	J.3.35
Assemblaggio guarnizione di finitura RU9704 .....	J.3.36
Assemblaggio tappo centrale CO1105/CO1104 profilato inferiore C9K120 .....	J.3.37

**OPERAZIONI C9K121 E ASSEMBLAGGIO BT6019**

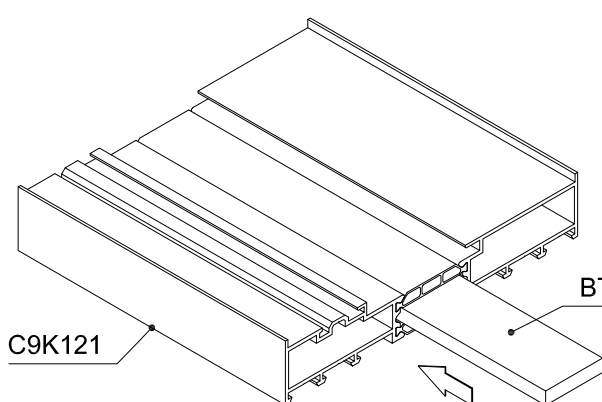
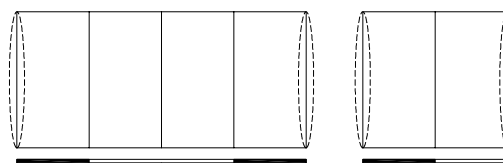
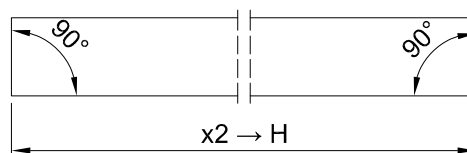
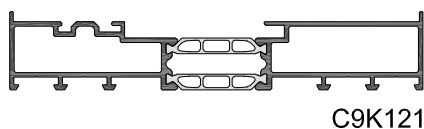
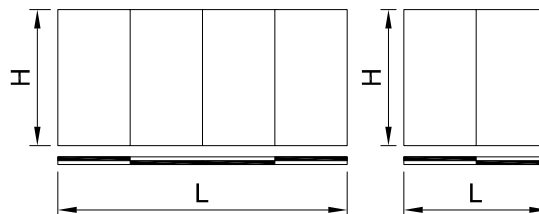

	BT6019
SHI	✓
SI	✓
I	x

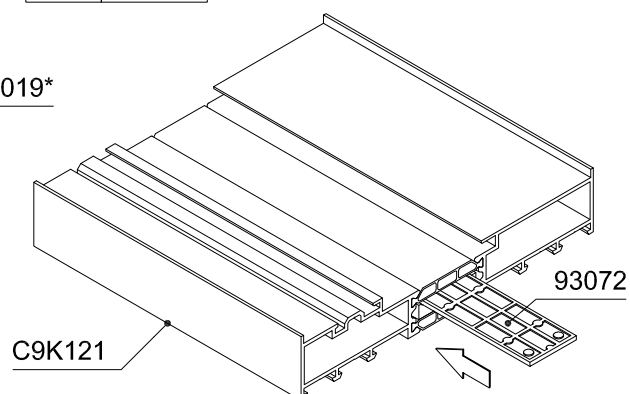

## 2-BINARI TELAIO TAGLI 90°

### OPERAZIONI C9K121 PER ASSEMBLAGGIO TELAIO

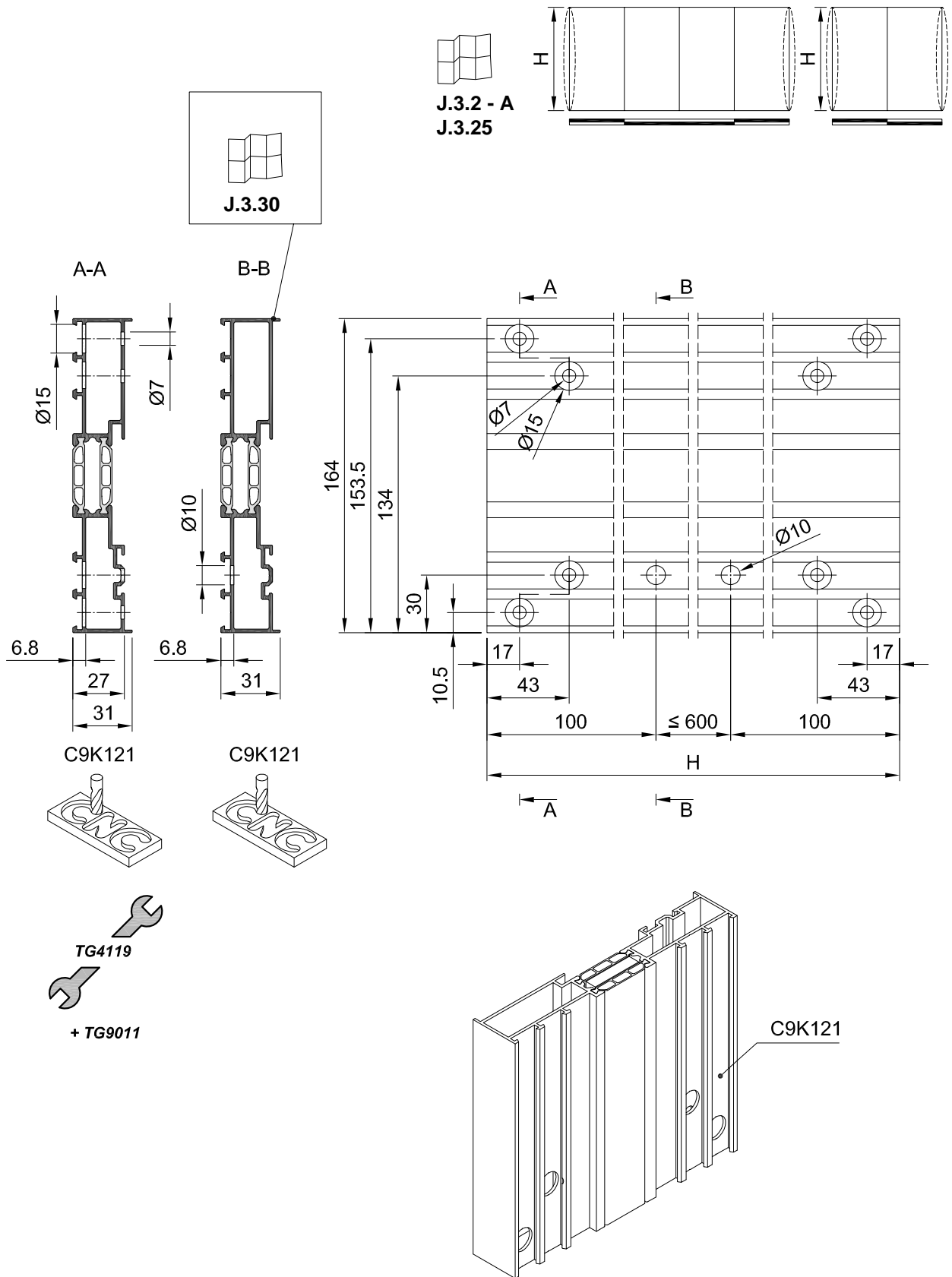

**OPERAZIONI C9K120 + KU2028 E ASSEMBLAGGIO BT6006**

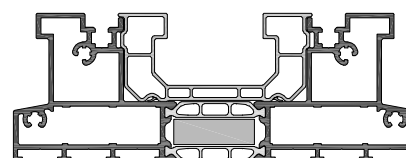
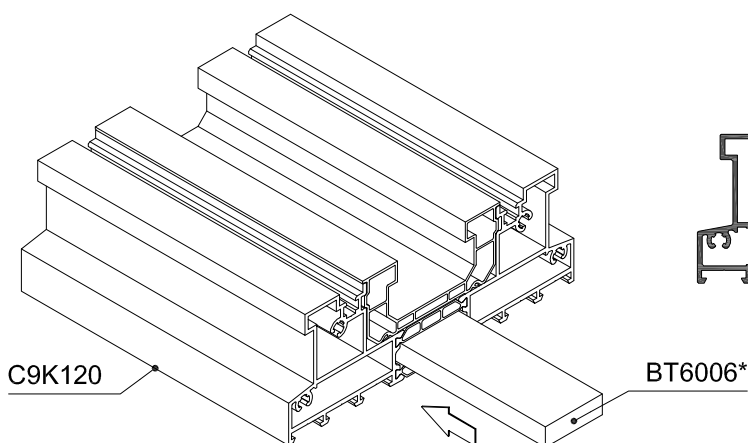
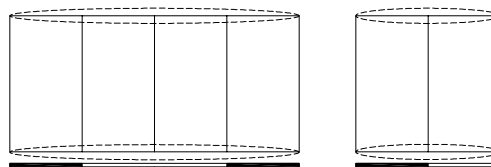
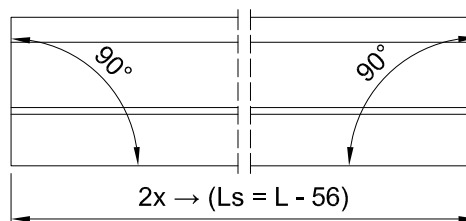
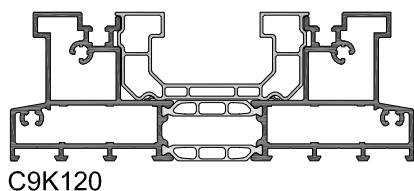
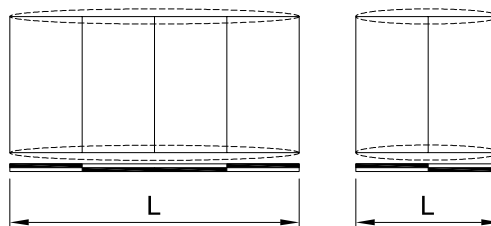
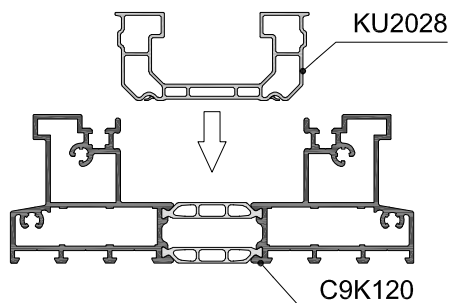

	BT6006
SHI	✓
SI	✓
I	x

## 2-BINARI TELAIO TAGLI 90°

### OPERAZIONI C9K120 PER CAPPETTA DI DRENAGGIO



J.3.2 - B  
J.3.22

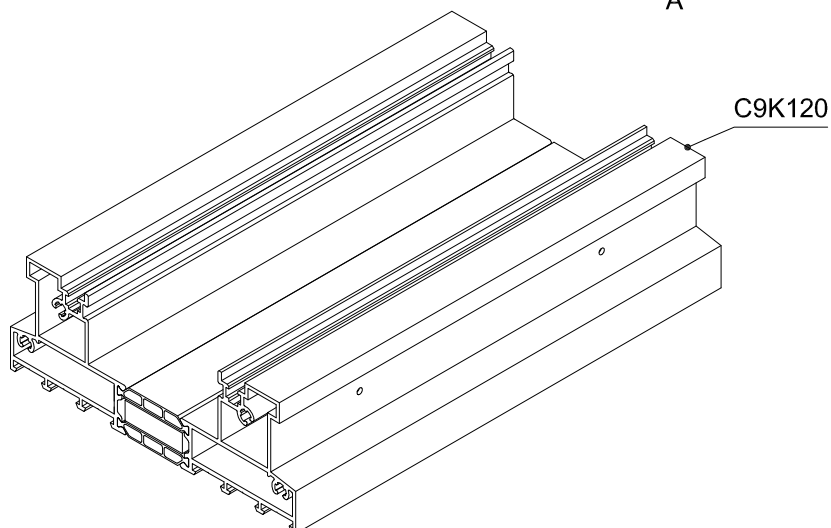
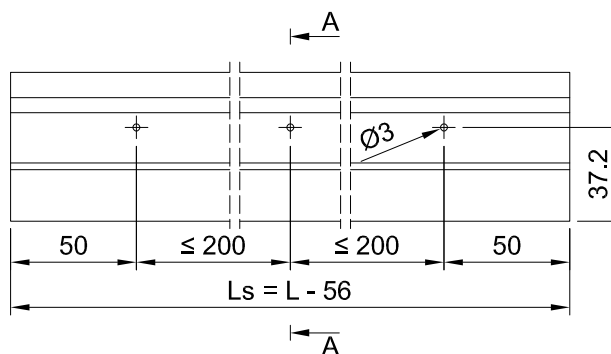
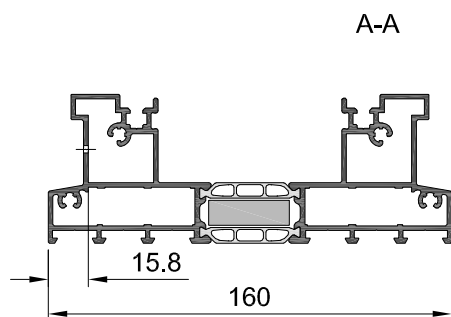
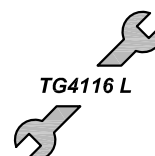
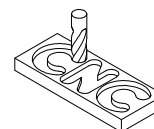
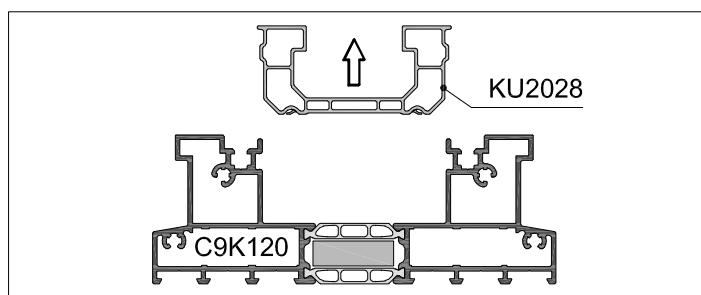
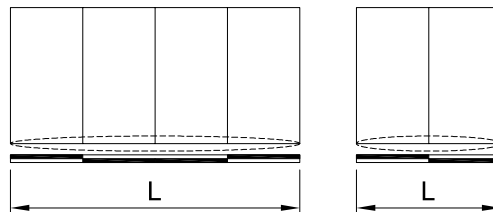

**C9K120 E KU2028 PANORAMICA DRENAGGI**

1 / 11

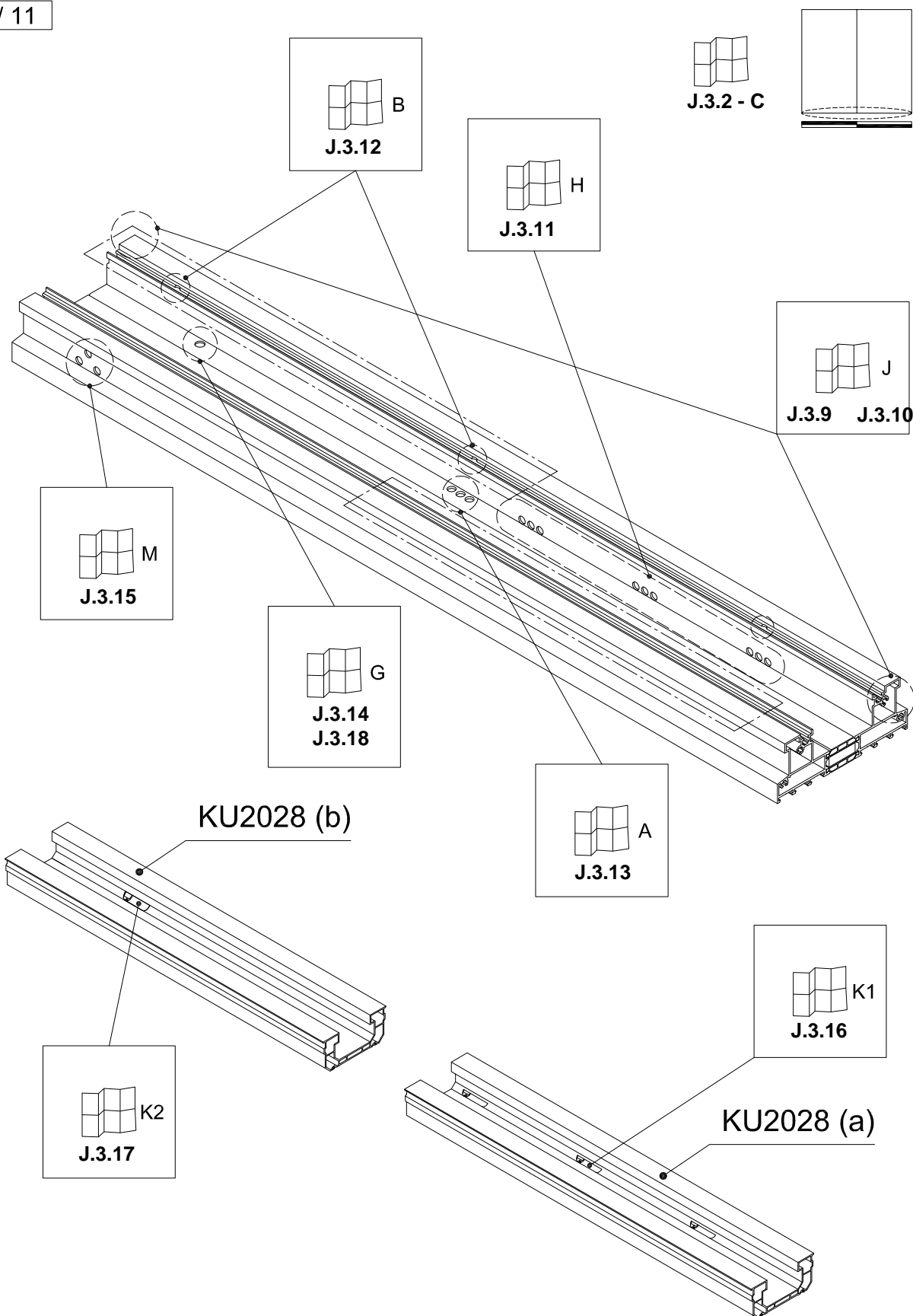

## 2-BINARI TELAIO TAGLI 90°

### C9K120 LAVORAZIONE DRENAGGIO - J (OPTIONAL 1/2)

2 / 11

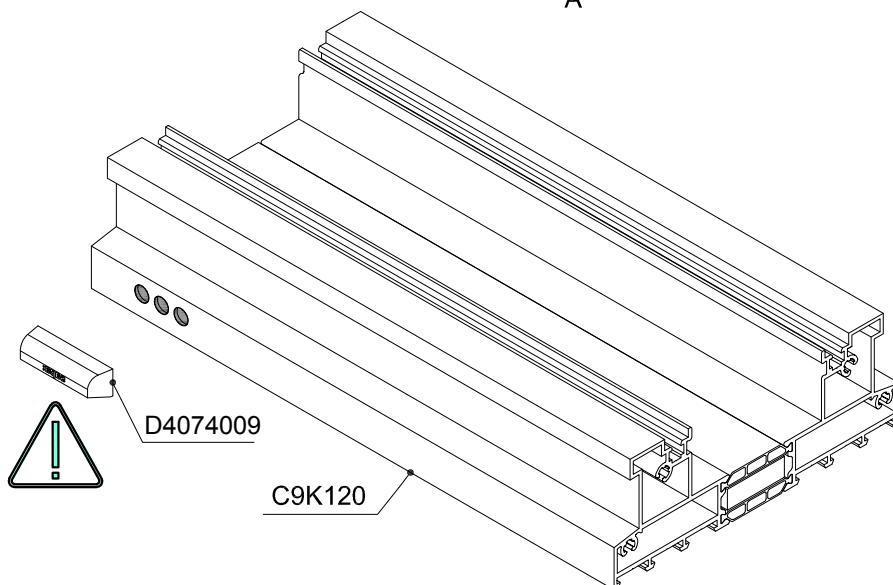
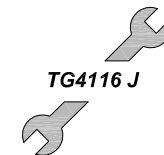
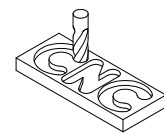
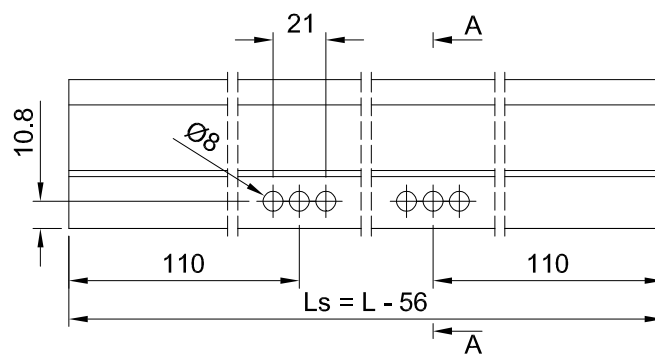
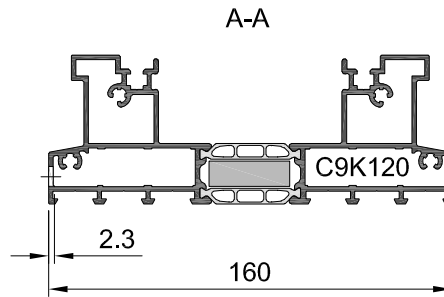
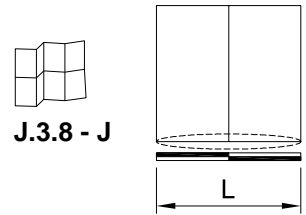

**C9K120 LAVORAZIONE DRENAGGIO - J (OPTIONAL 2/2)**

3 / 11

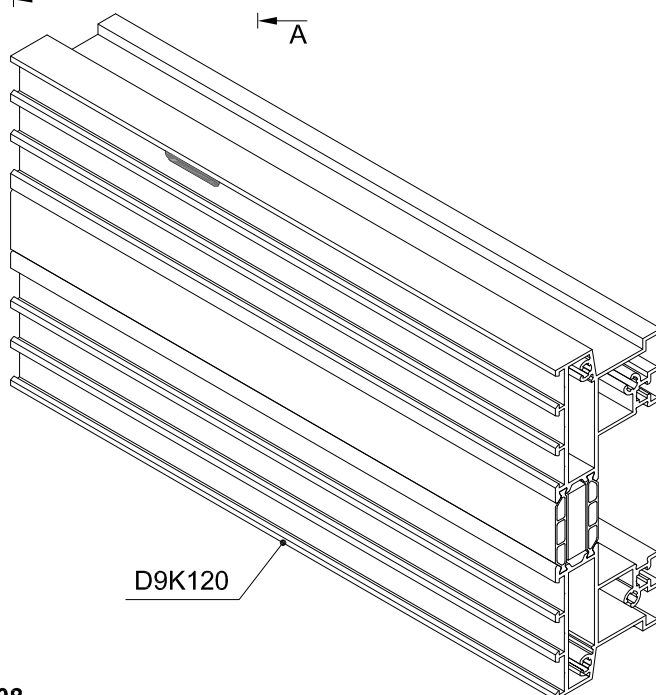
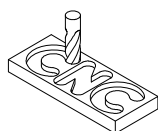
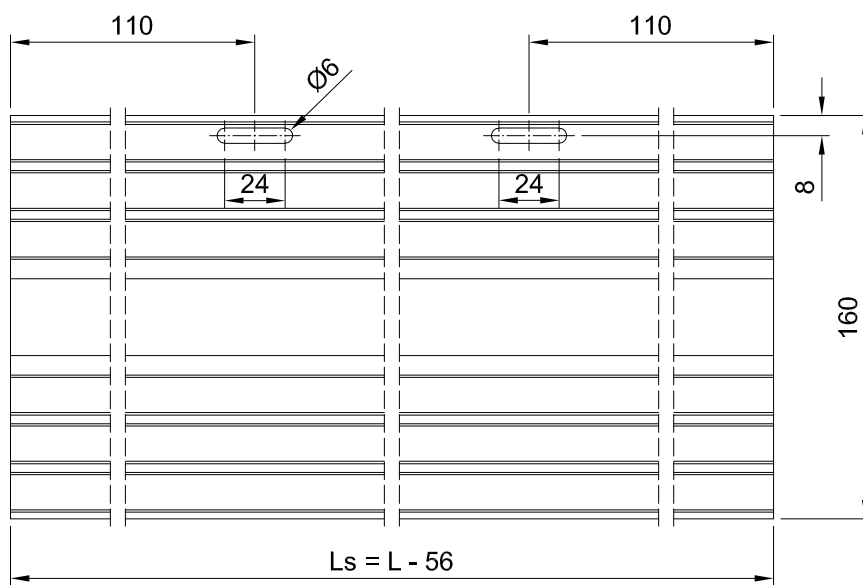
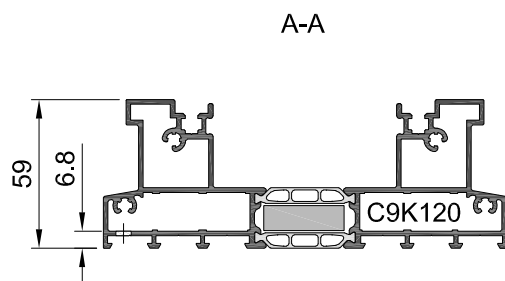
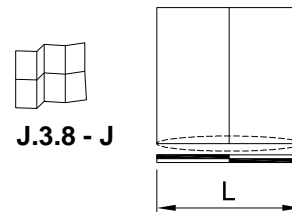



## 2-BINARI TELAIO TAGLI 90°

### C9K120 LAVORAZIONE DRENAGGIO - H

4 / 11

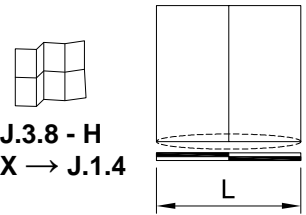

J.3.8 - H  
X → J.1.4

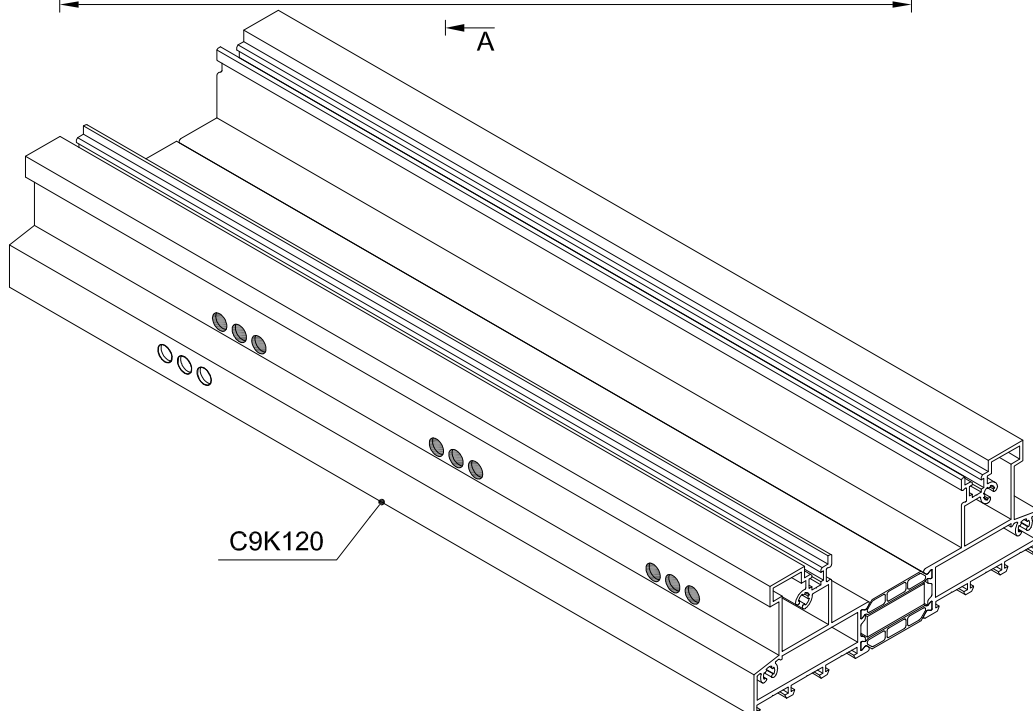
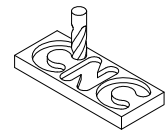
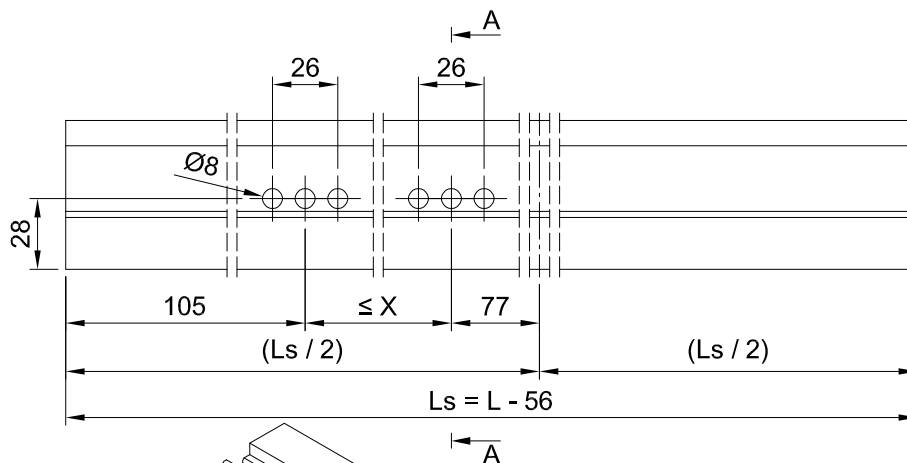
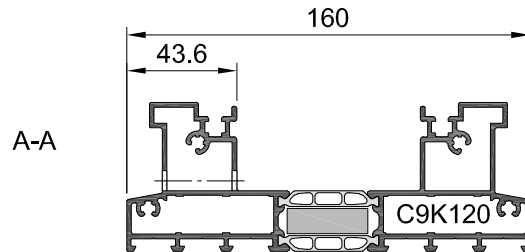

C9K120 LAVORAZIONE DRENAGGIO - B

5 / 11

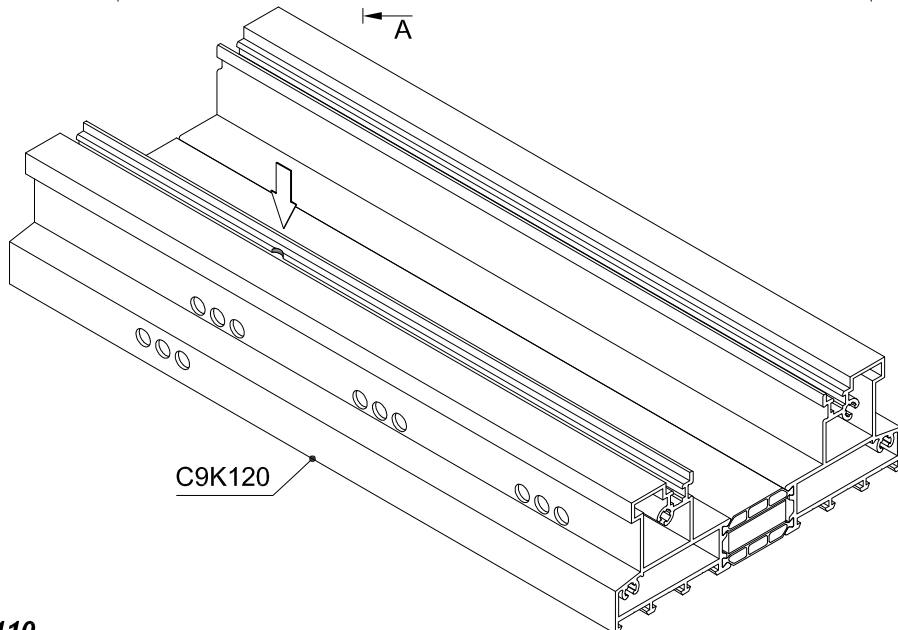
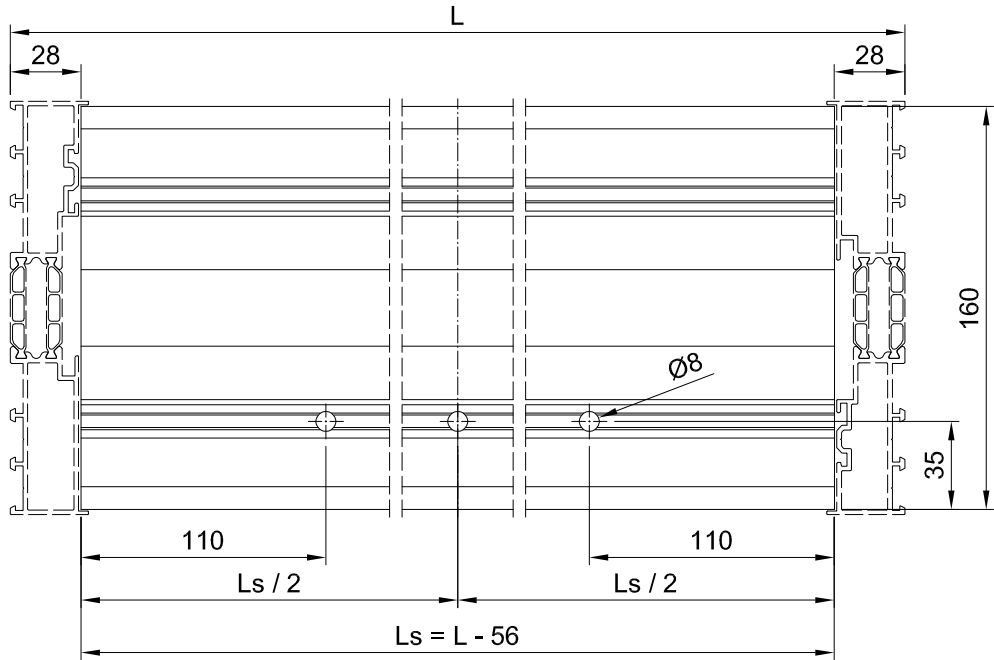
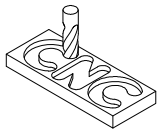
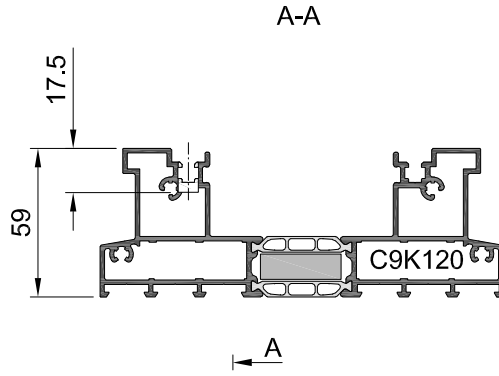
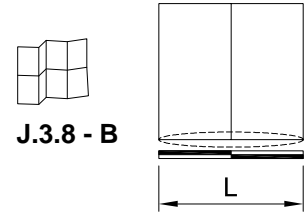

2-BINARI TELAIO TAGLI 90°

C9K120 LAVORAZIONE DRENAGGIO - A

6 / 11

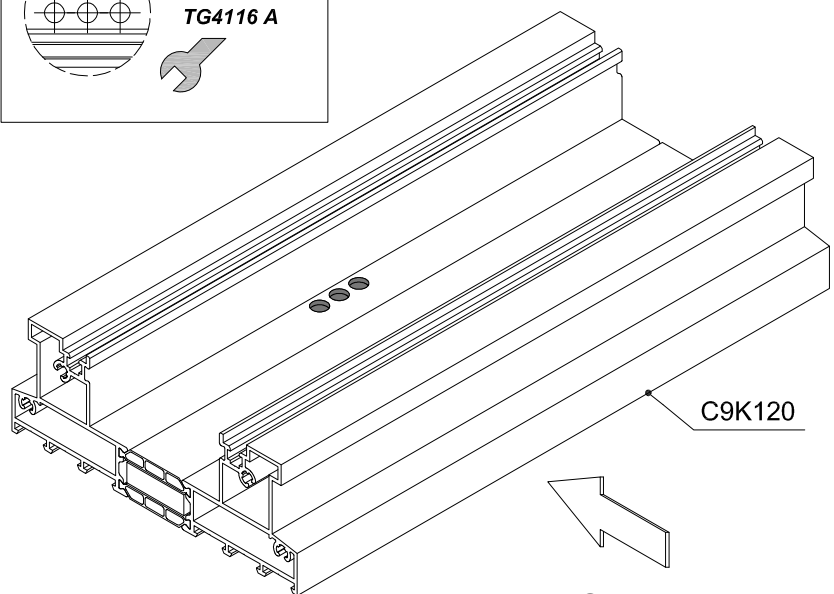
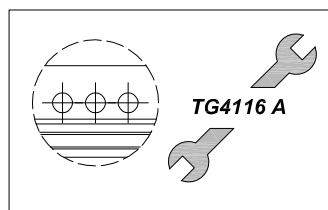
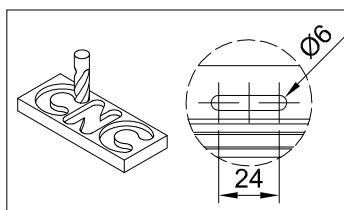
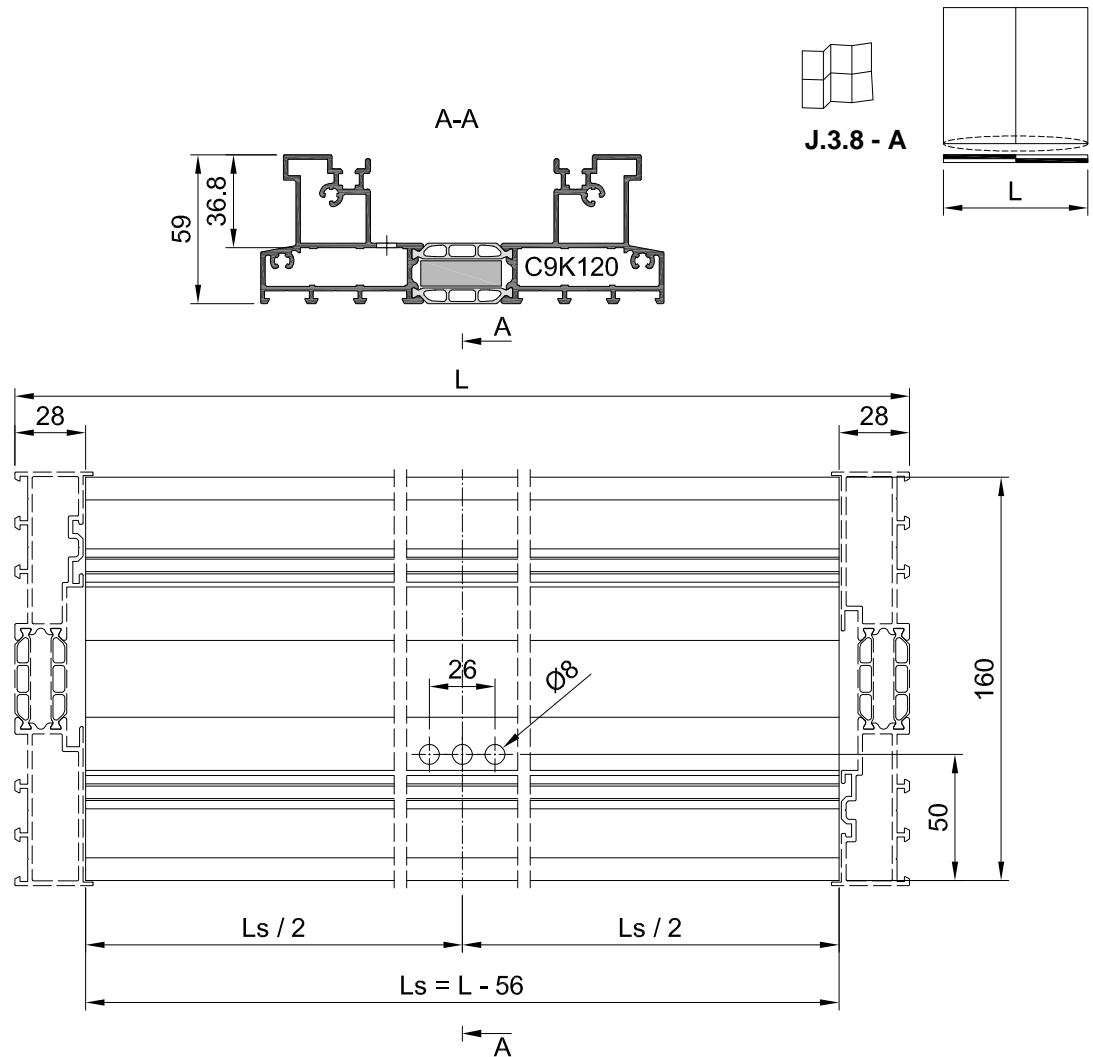

VISTA INTERNA

**C9K120 LAVORAZIONE DRENAGGIO - G**

7 / 11



**J.3.8 - G**  
**J.3.18**

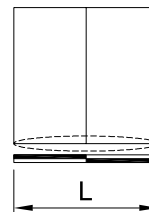

A-A

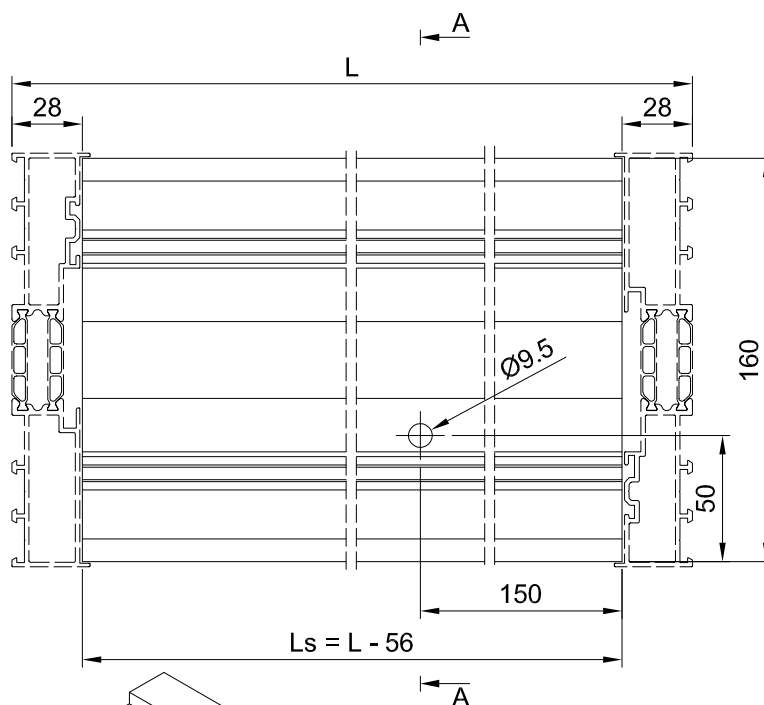
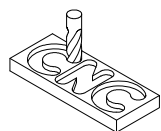
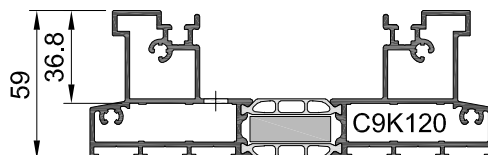

**VISTA INTERNA**

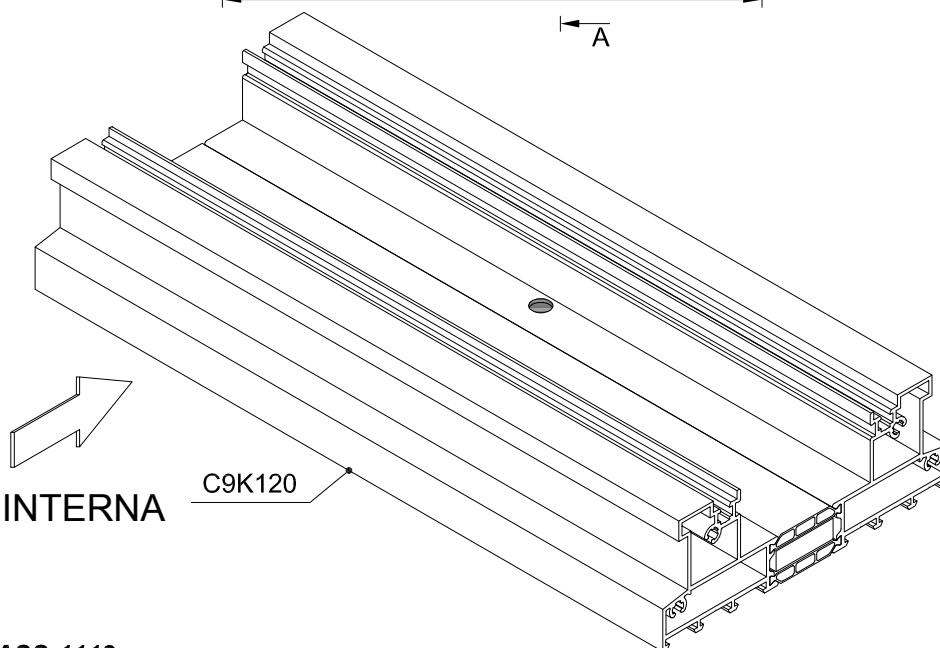

 **C160-ASS-1112**

### C9K120 LAVORAZIONE DRENAGGIO - M

8 / 11

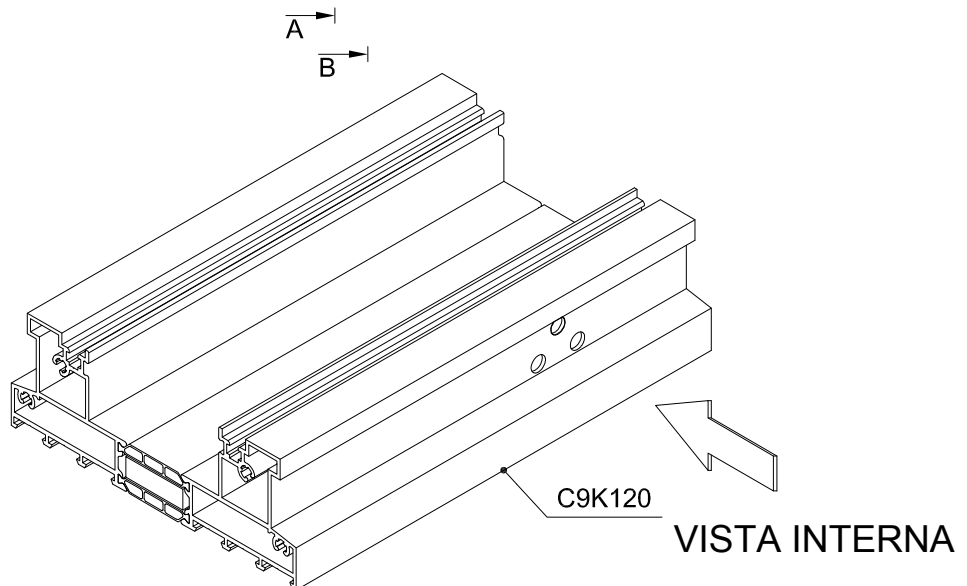
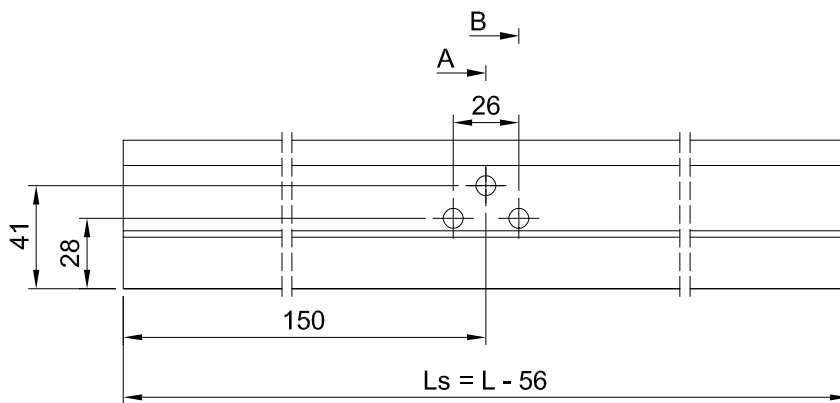
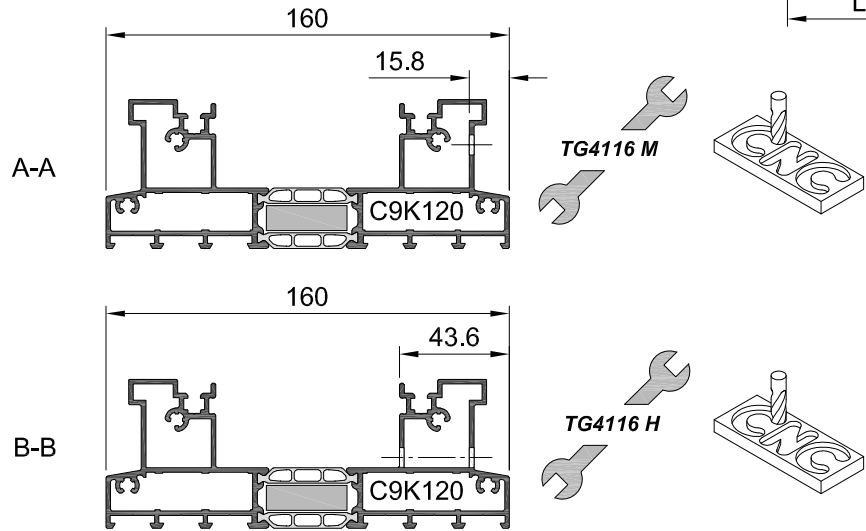
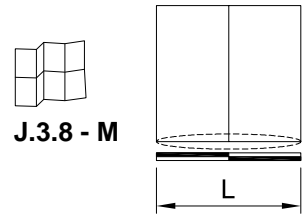

**KU2028 LAVORAZIONE DRENAGGIO - K1**

9 / 11



**J.3.8 - K1**  
**X → J.1.4**

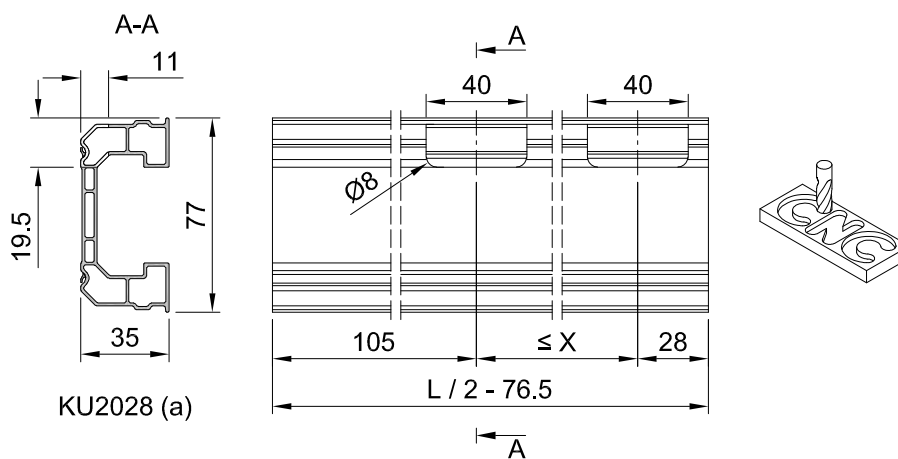
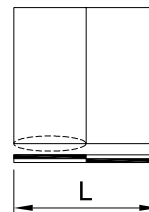

KU2028 (a)

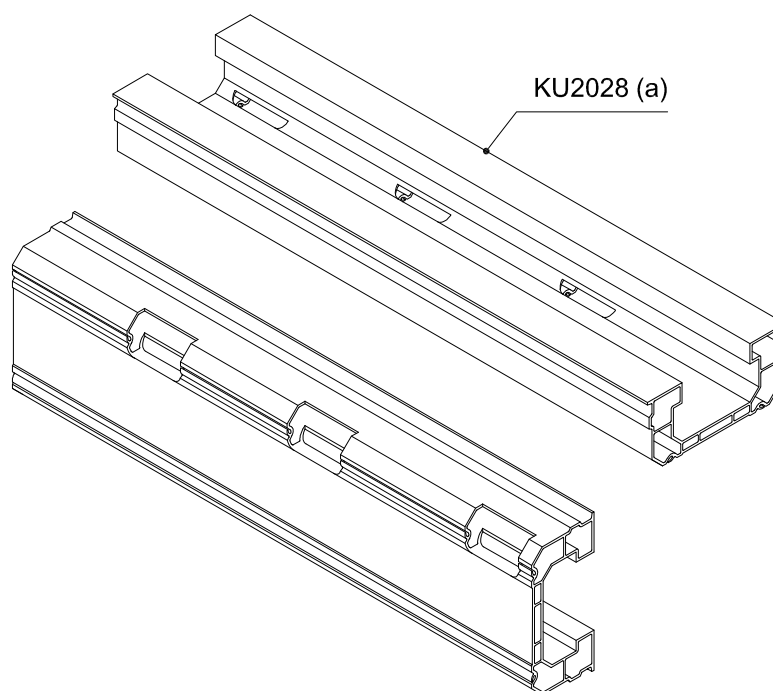

KU2028 LAVORAZIONE DRENAGGIO - K2

10 / 11

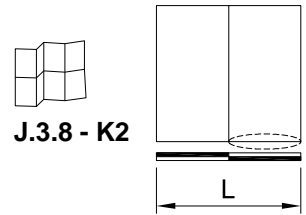

J.3.8 - K2

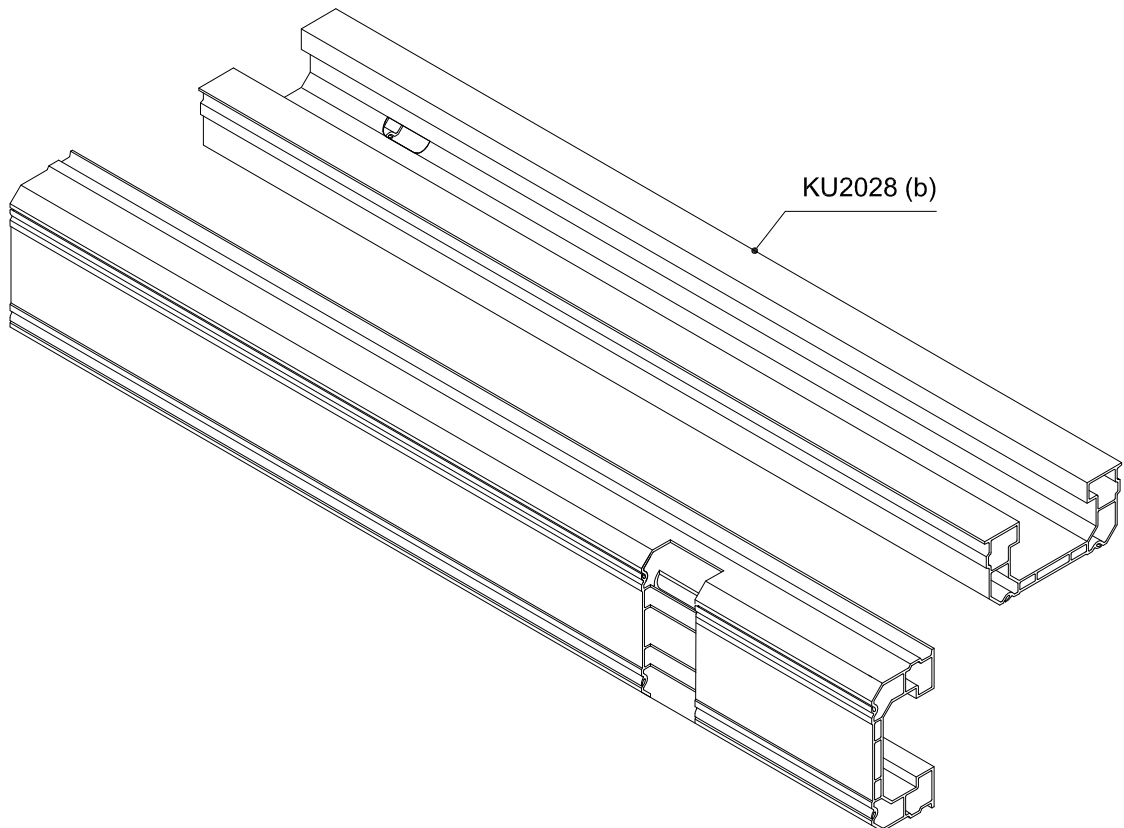
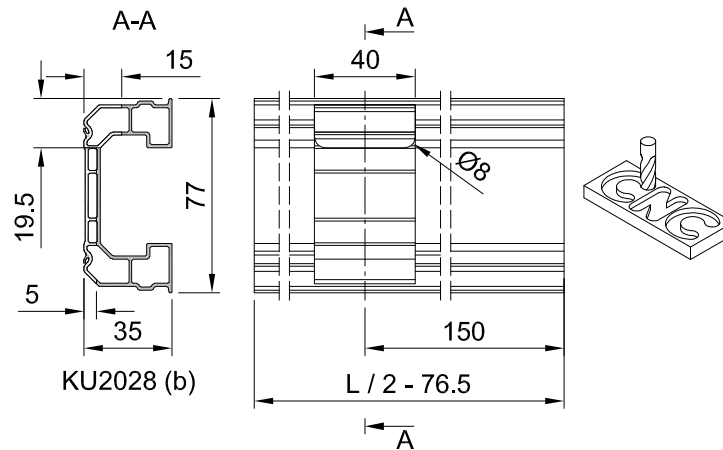

**ASSEMBLAGGIO VS0107 E KU2028 SU C9K020 PROFILATO INFERIORE C9K120**

11 / 11

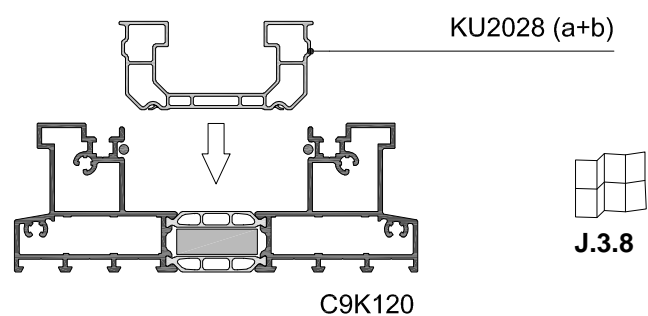
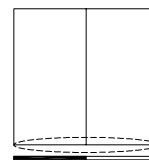
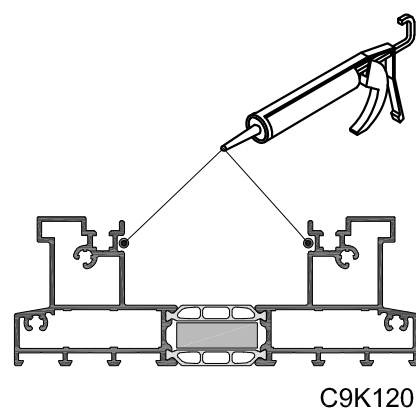
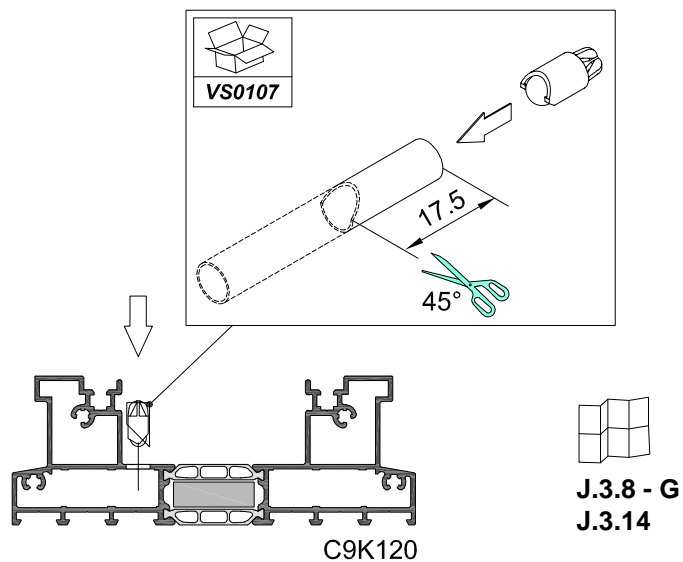
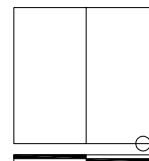



### ASSEMBLAGGIO TAPPO CENTRALE CO1105 PROFILATO INFERIORE C9K120

1 / 2

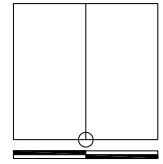

J.3.2 - D  
J.3.37

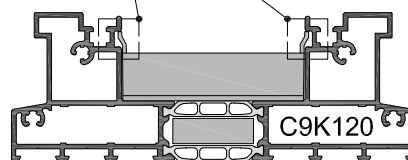
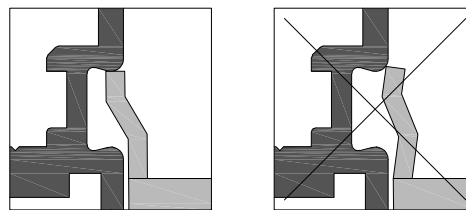
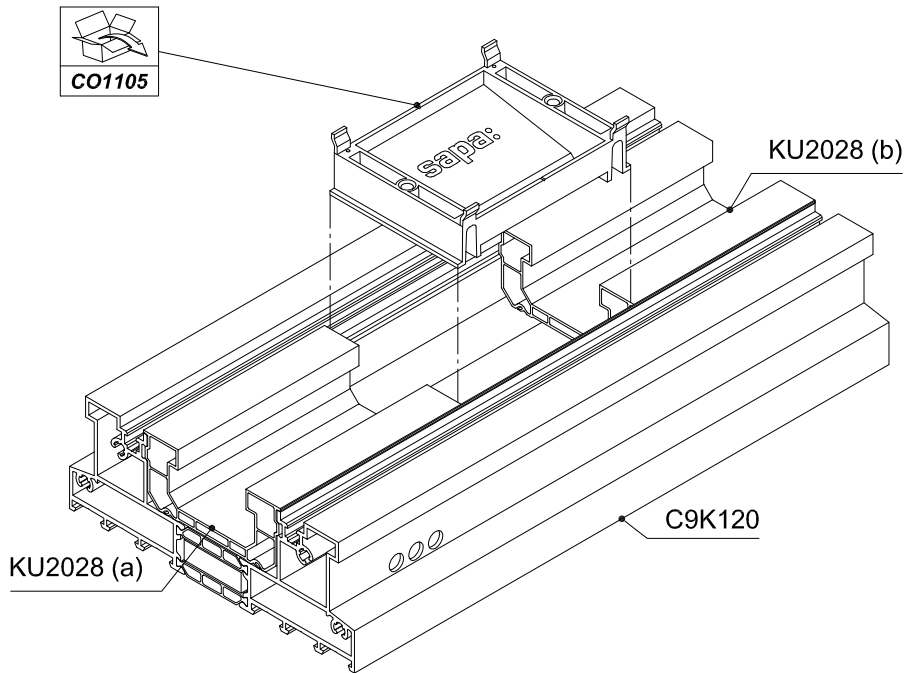

**ASSEMBLAGGIO TAPPO CENTRALE CO1105/CO1104 PROFILATO INFERIORE C9K120**

2 / 2



J.3.2 - D  
J.3.37

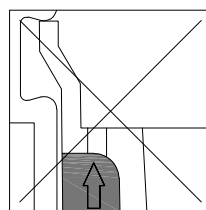
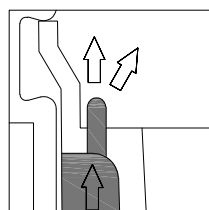
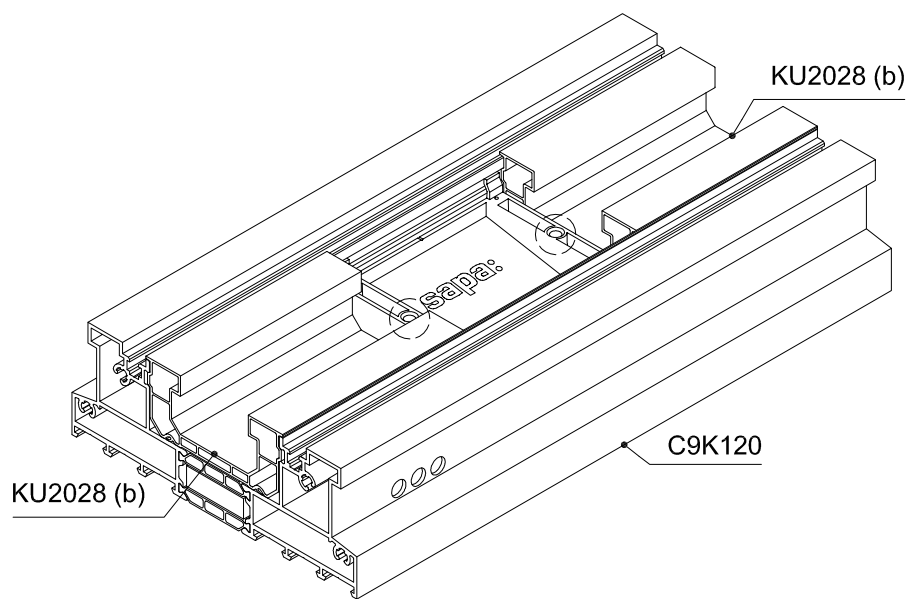
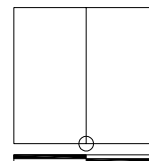

silicone

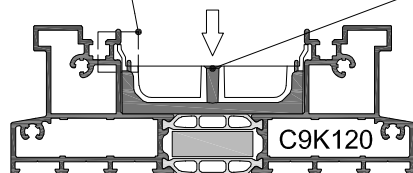
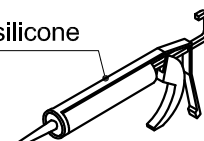

ASSEMBLAGGIO TAPPO CENTRALE CO1111 PROFILATO SUPERIORE C9K120

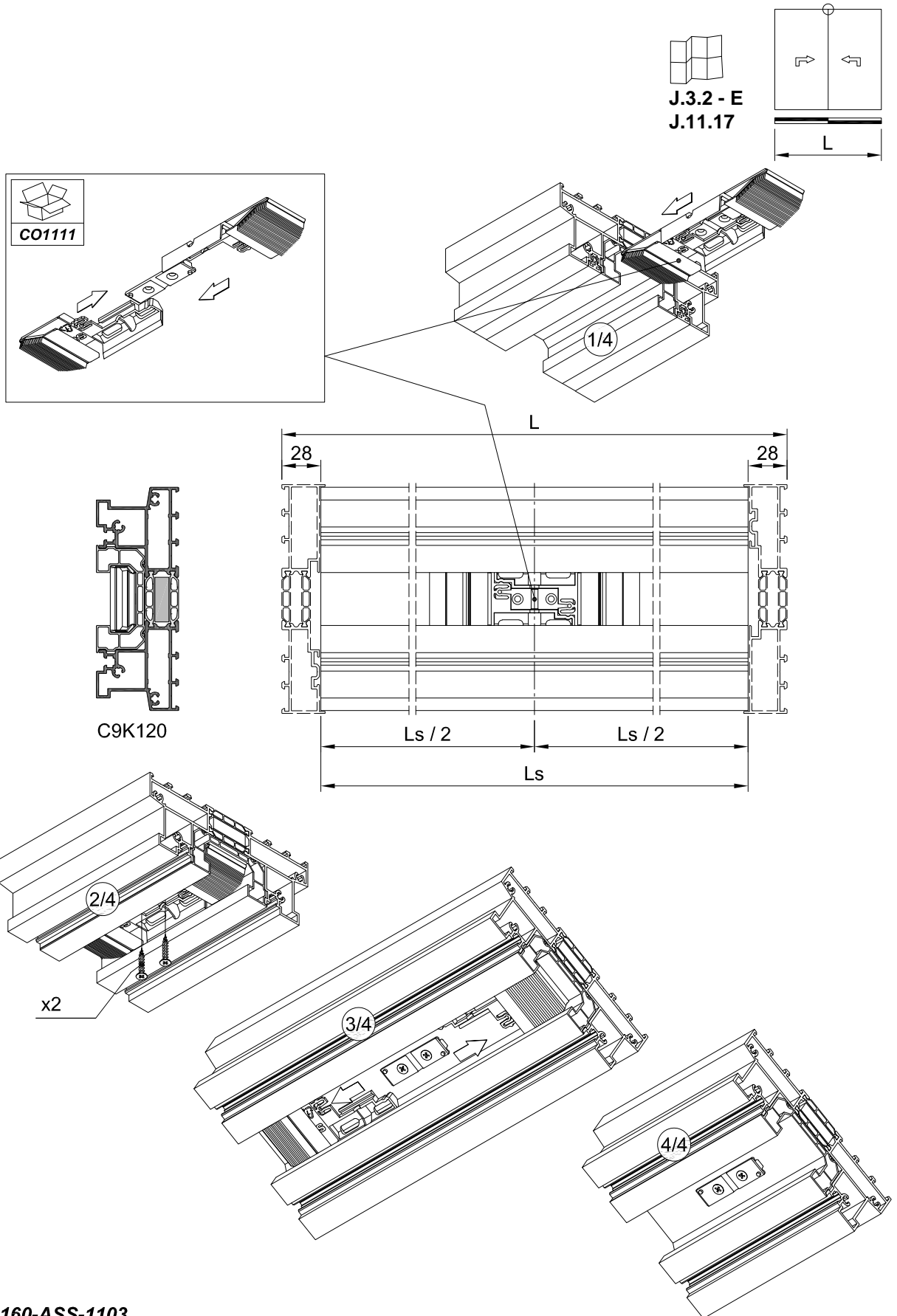

C160-ASS-1103

**ASSEMBLAGGIO CAPPETTA DI DRENAGGIO C9A003**



J.3.2 - B  
J.3.7

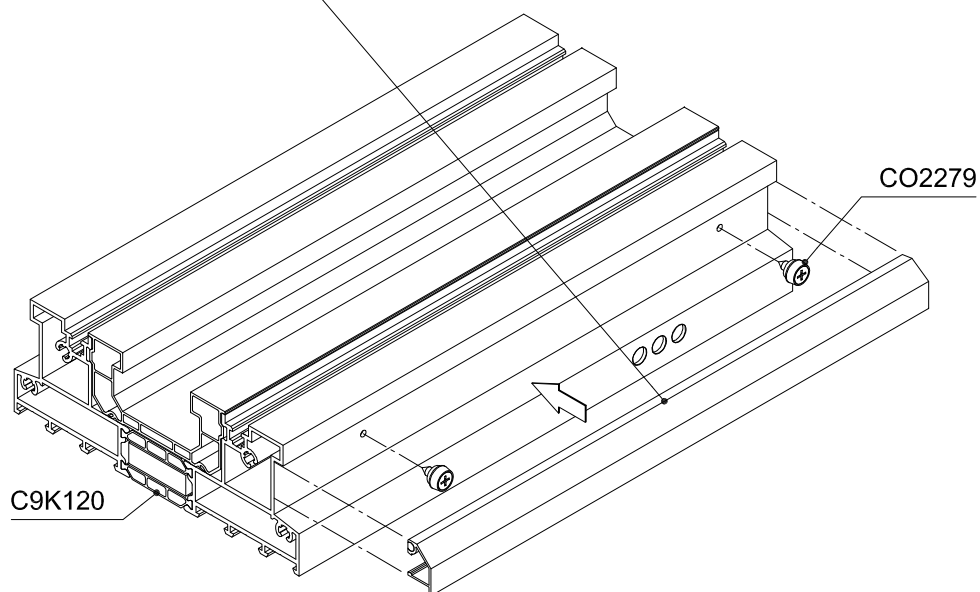
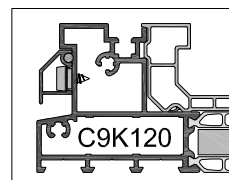
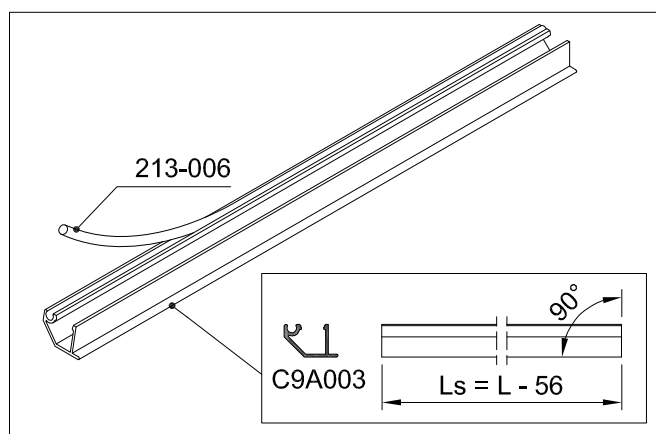
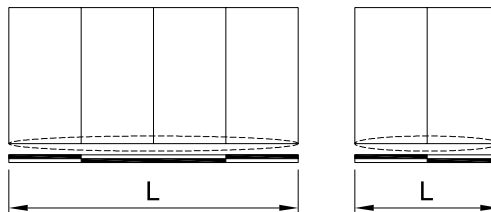

### OPERAZIONI C9A004

1 / 2



J.3.2 - H

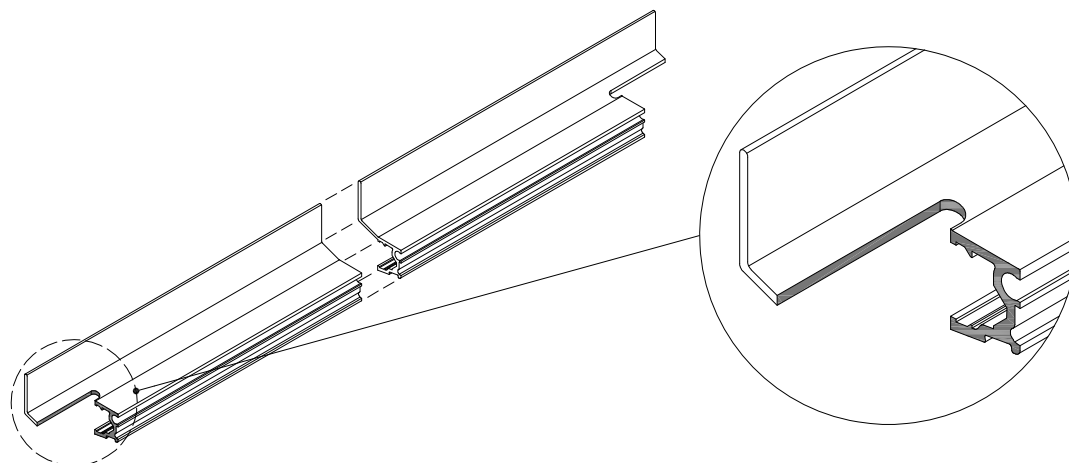
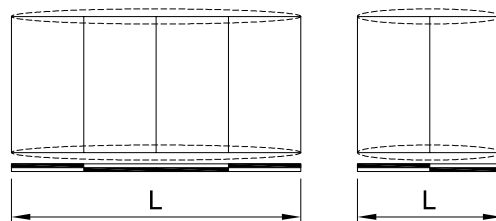

1/3

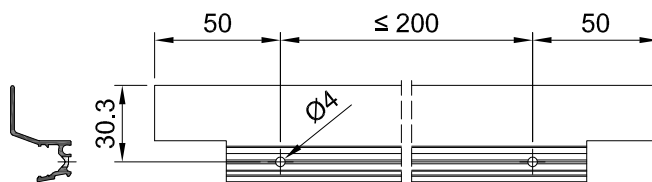

2/3

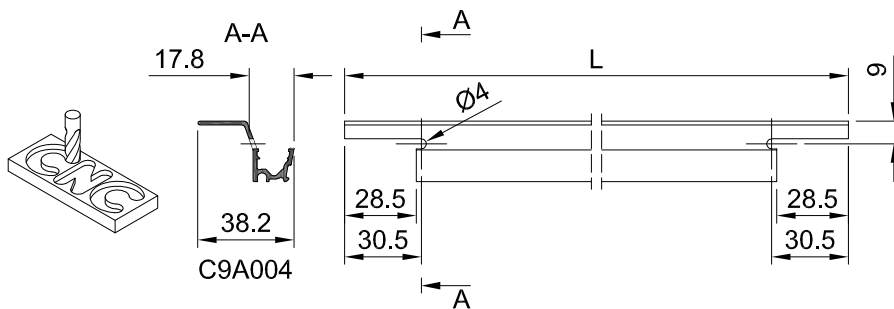

3/3

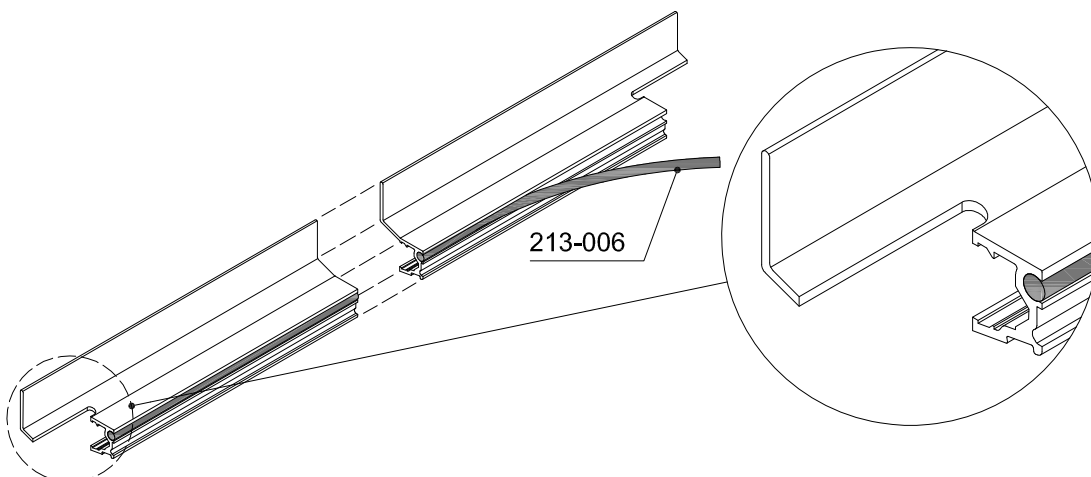

**ASSEMBLAGGIO C9A004**

2 / 2



J.3.2 - H

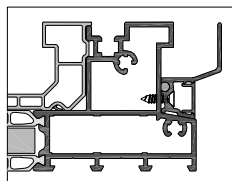
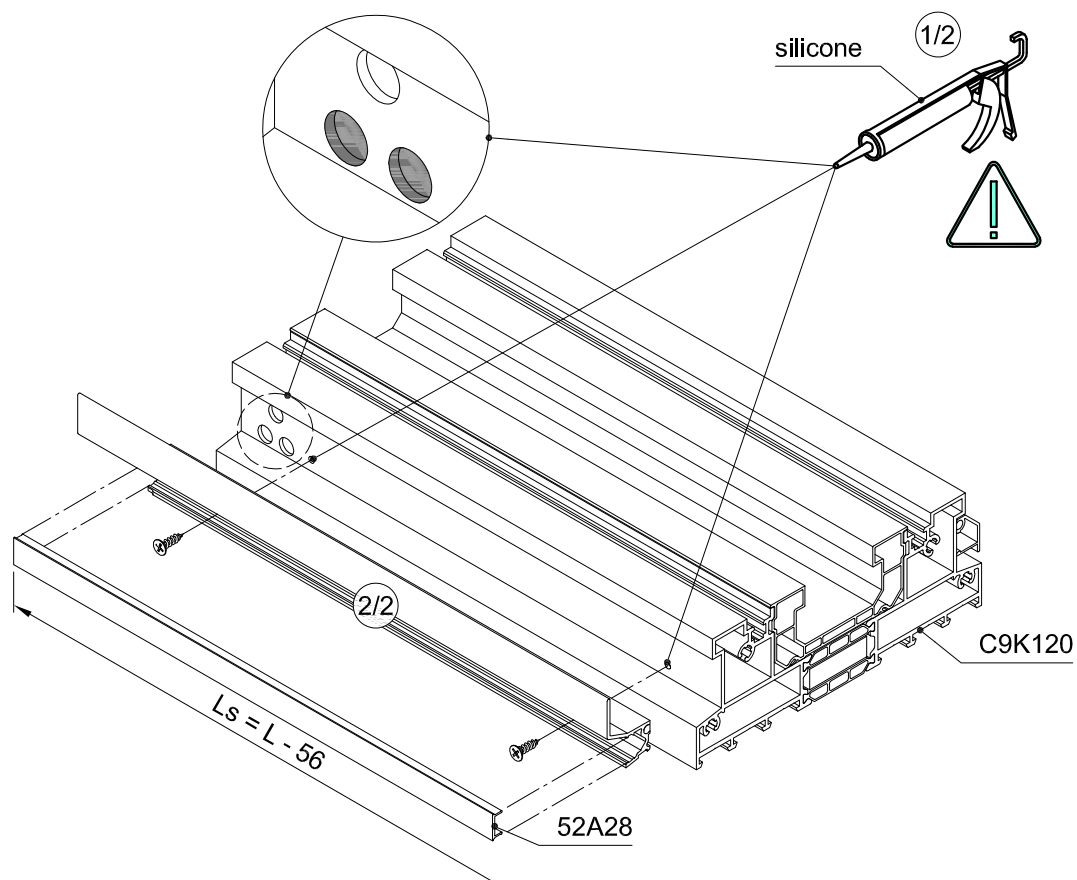
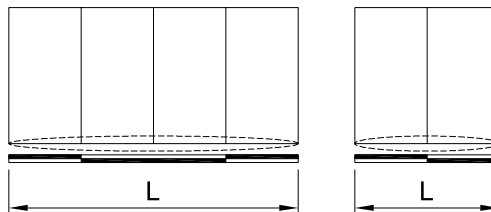

### ASSEMBLAGGIO CO0132 E VS9957 SU C9K121

1 / 3



J.3.2 - A  
J.3.5

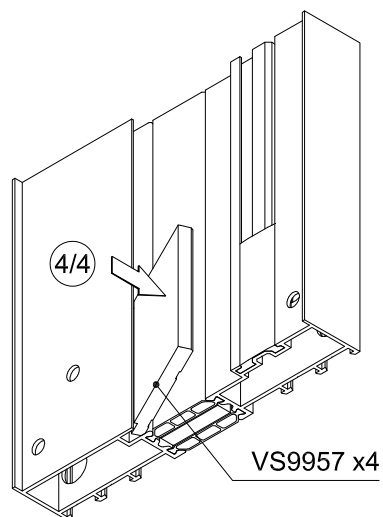
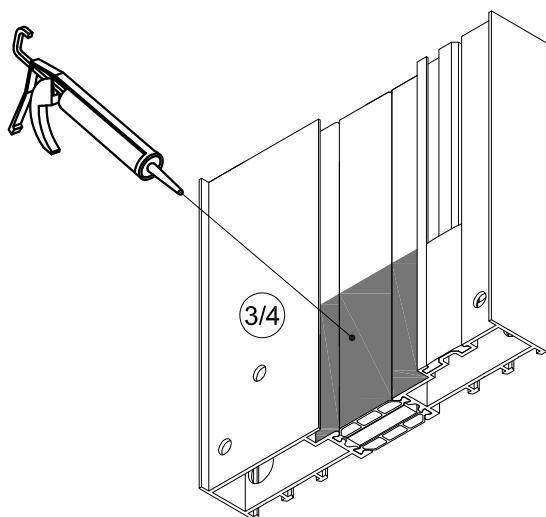
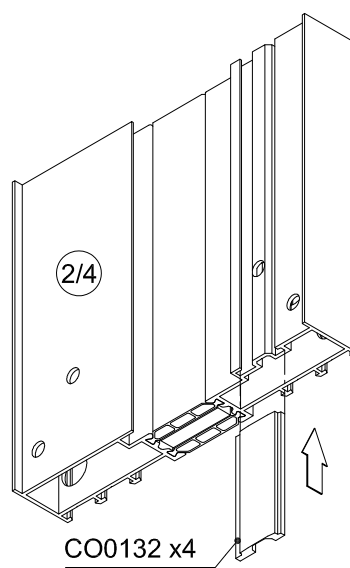
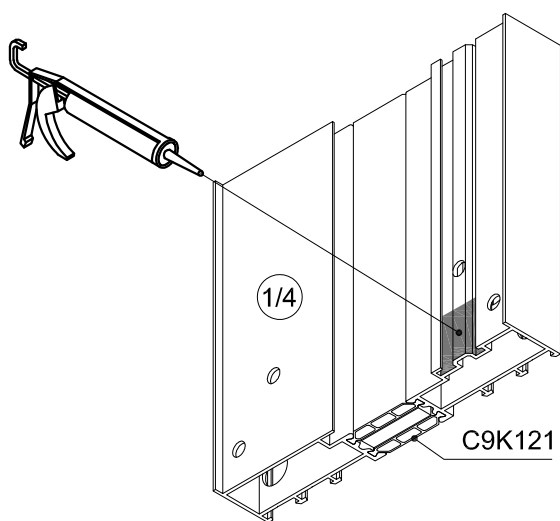
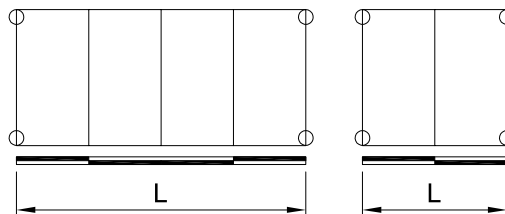

**ASSEMBLAGGIO VS9999 SU C9K121 E ASSEMBLAGGIO TELAIO**

2 / 3



J.3.2 - A  
J.3.5

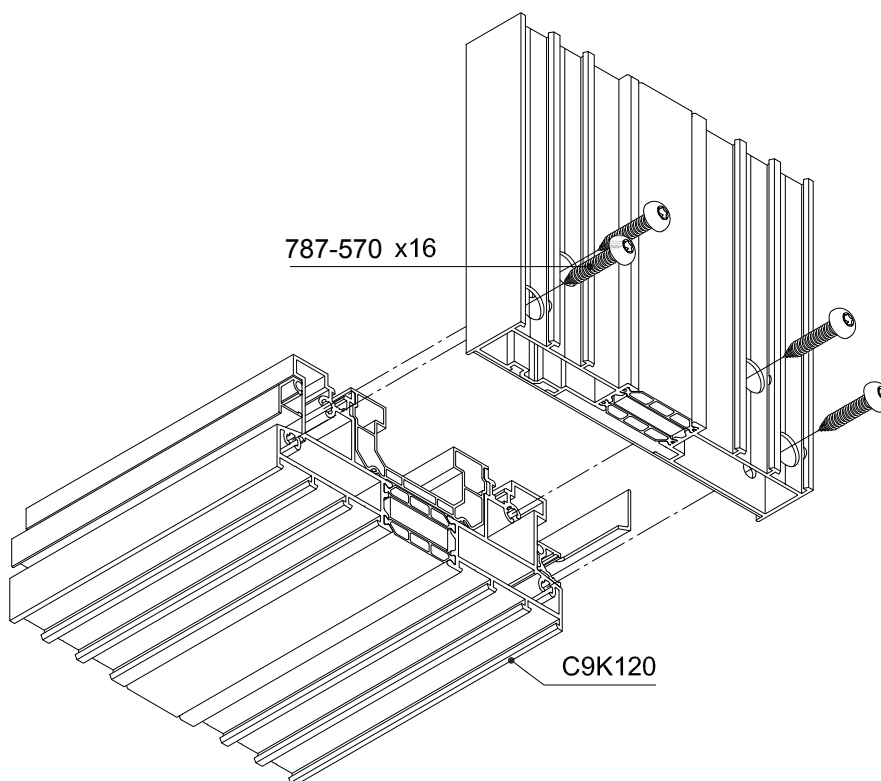
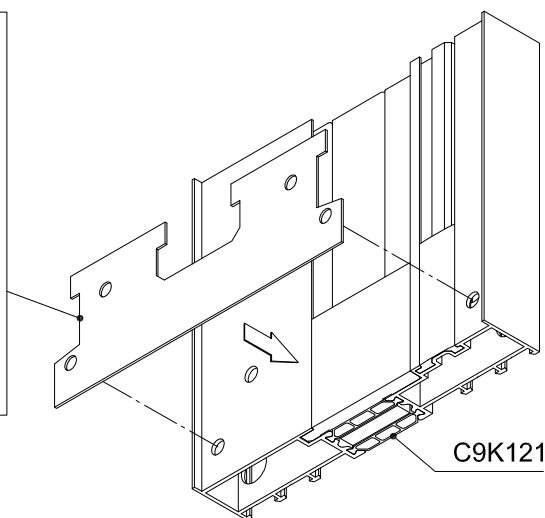
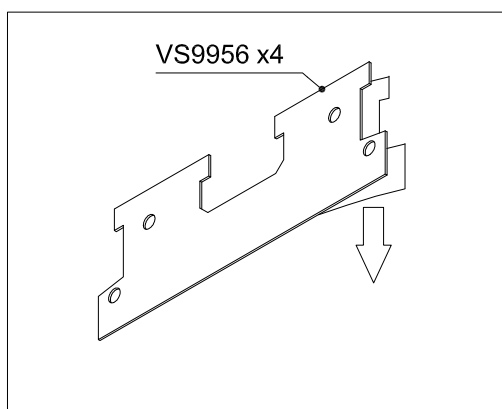
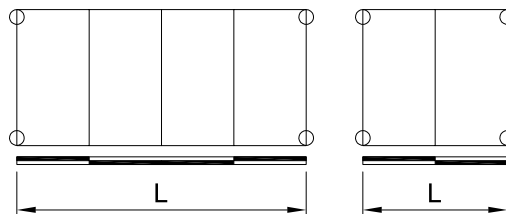



### SIGILLATURA C9A004

3 / 3



J.3.2 - A  
J.3.5

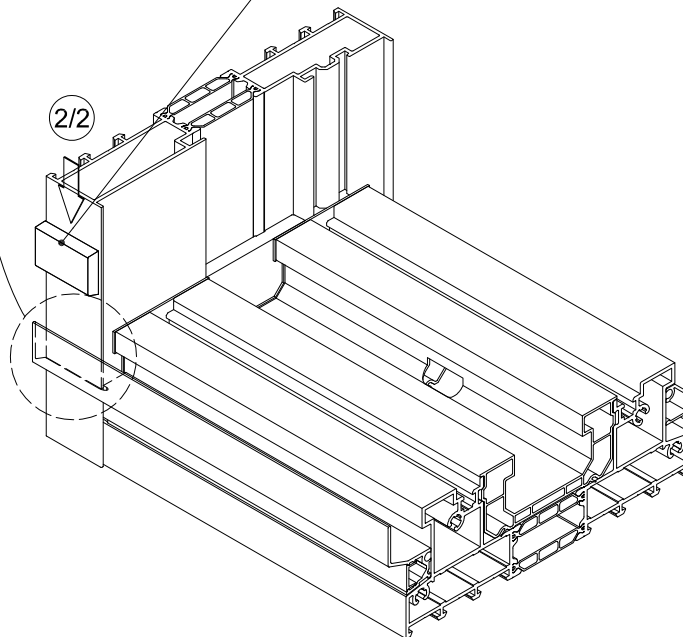
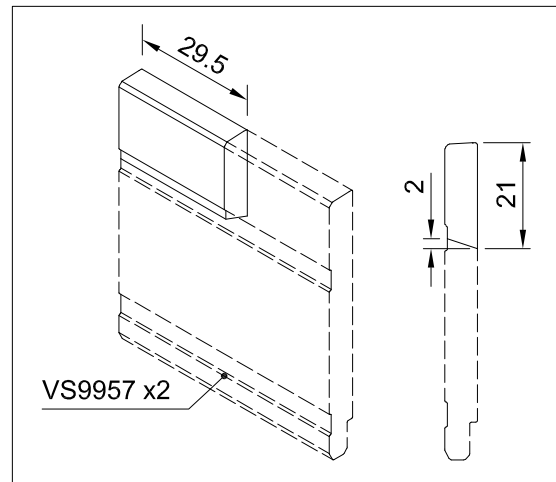
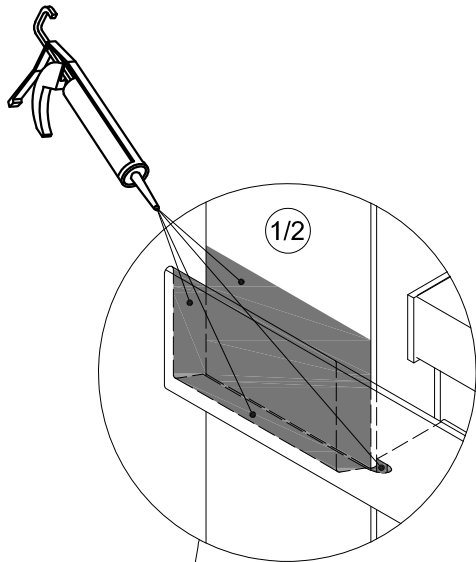
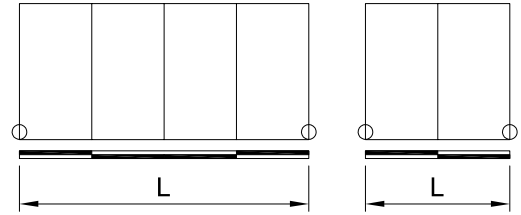

**ASSEMBLAGGIO PUNTI DI CHIUSURA (ZB0034/ZB0035/ZB0036)**

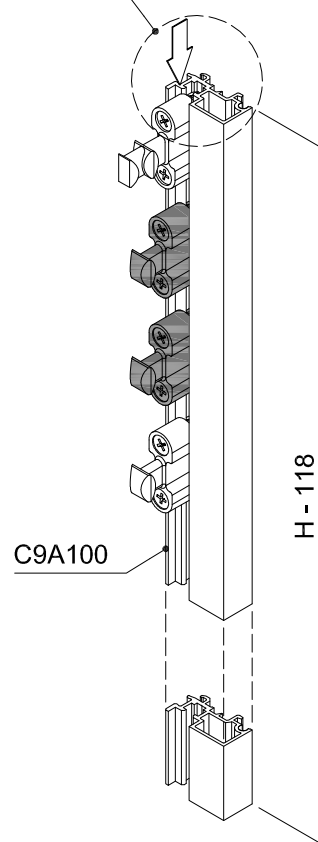
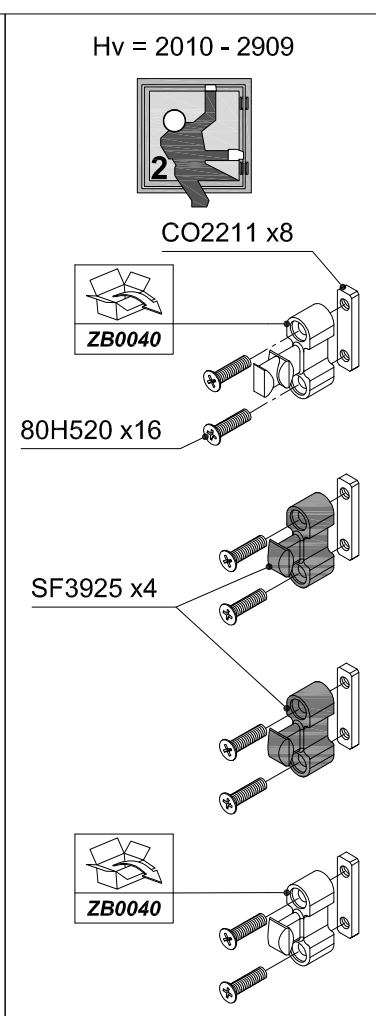
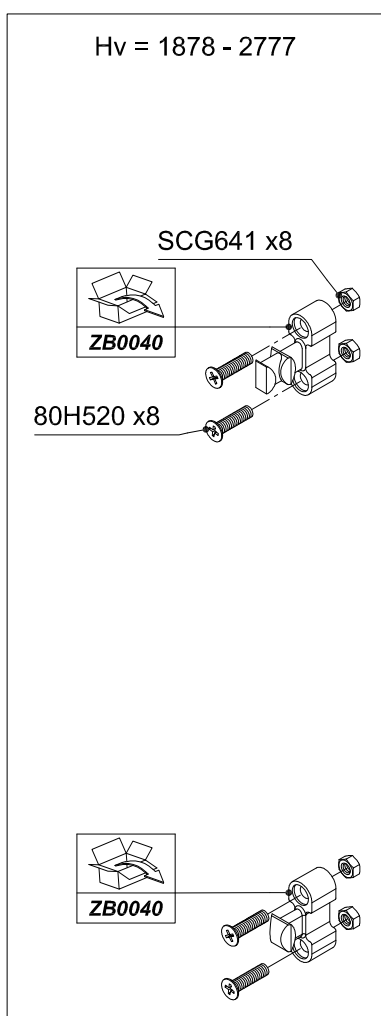
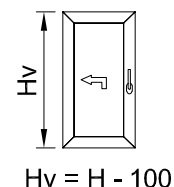
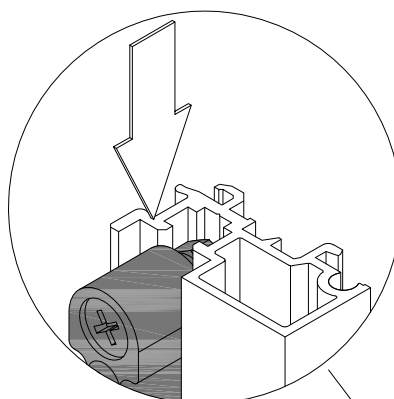
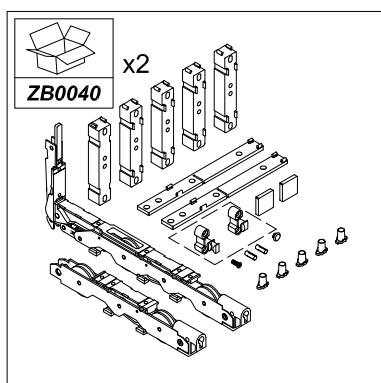
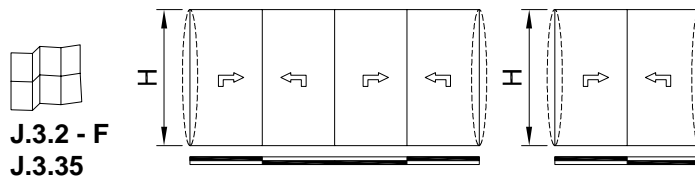

### ASSEMBLAGGIO RU9704

1 / 3

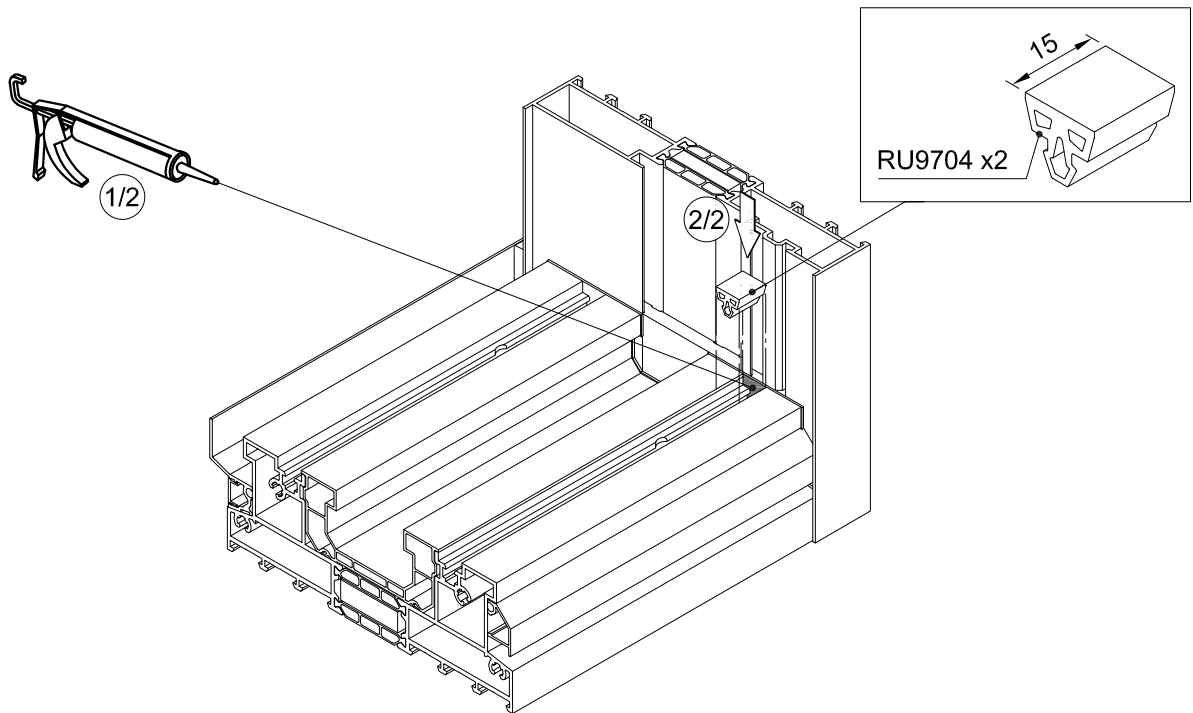
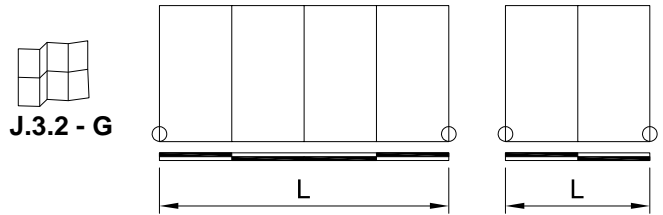

**ASSEMBLAGGIO C9A100**

2 / 3



**J.3.2 - G**

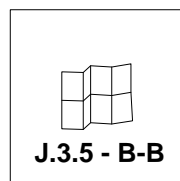
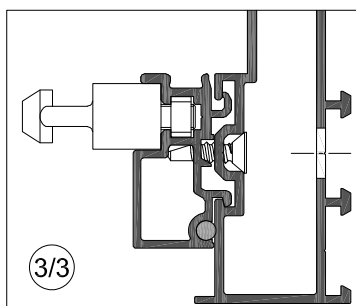
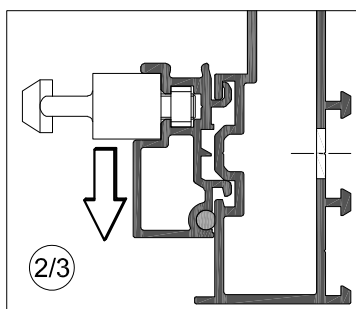
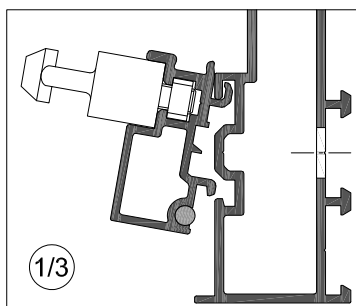
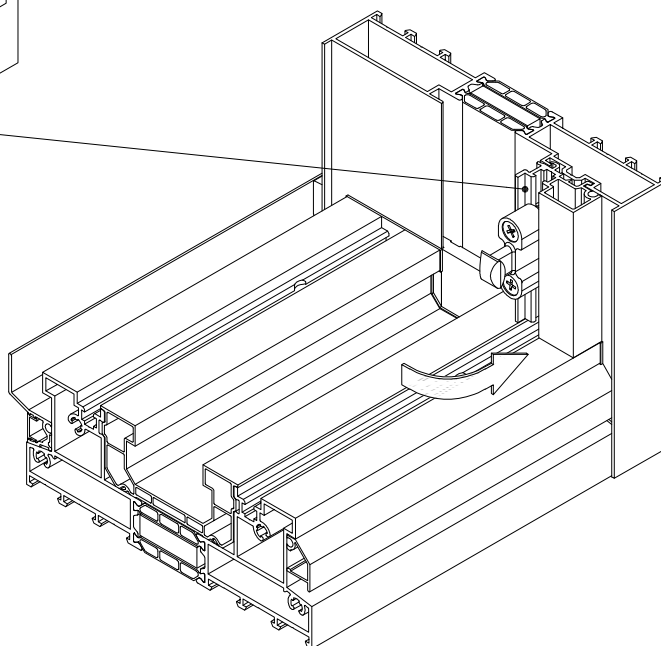
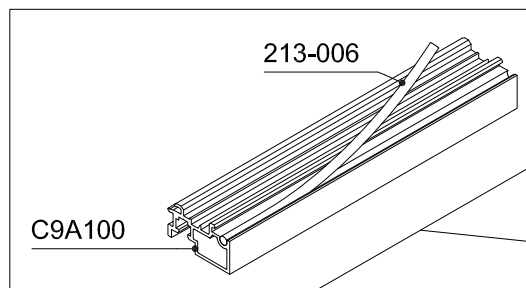
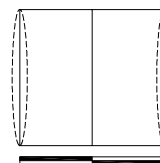
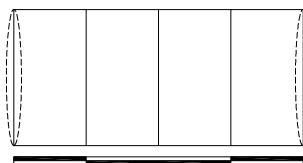

**J.3.5 - B-B**

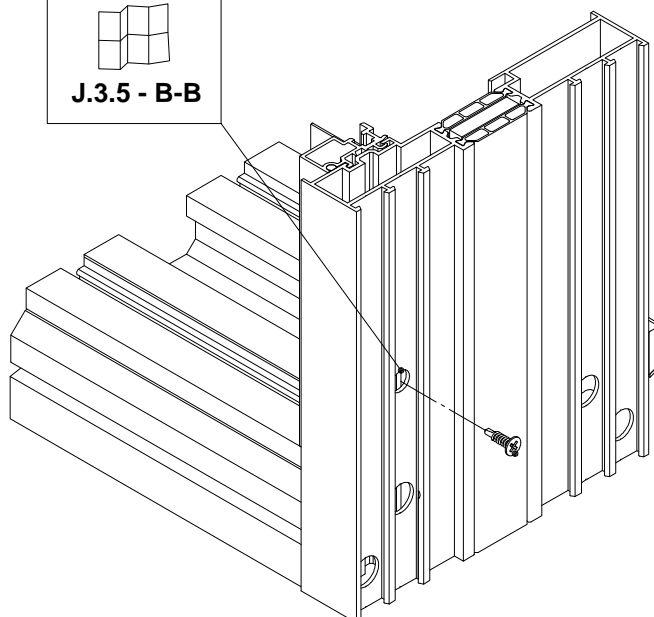

ASSEMBLAGGIO KU2035

3 / 3

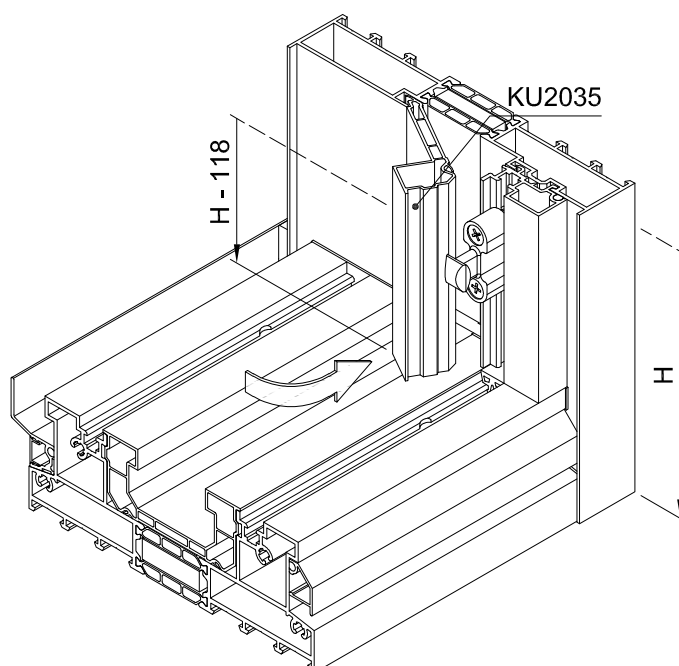
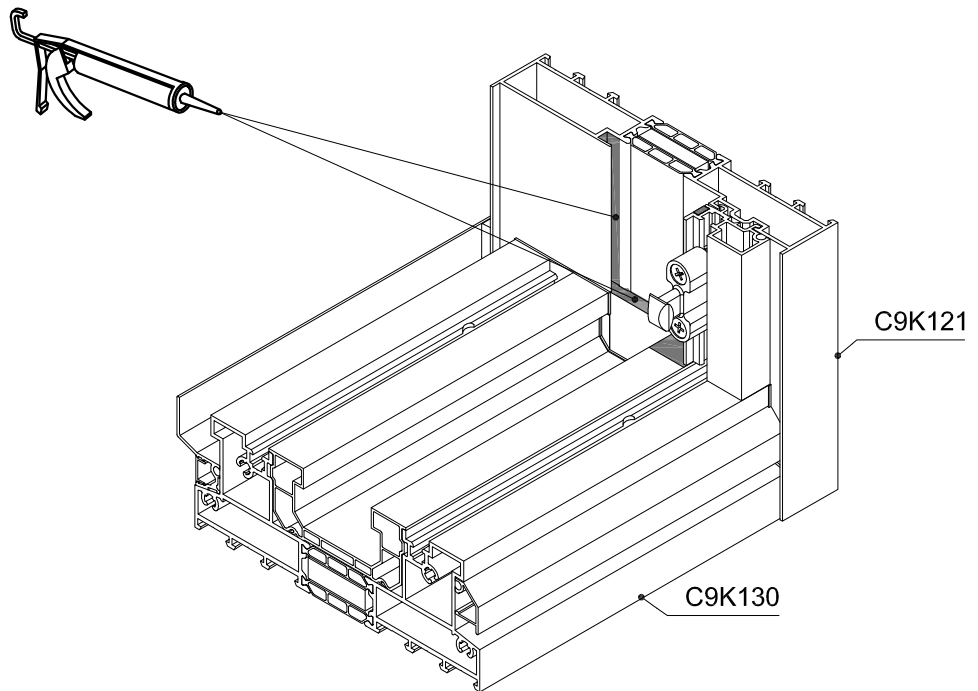
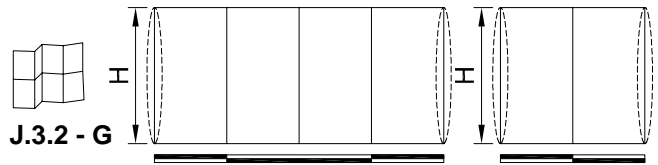

**ASSEMBLAGGIO CO1103**

1 / 3

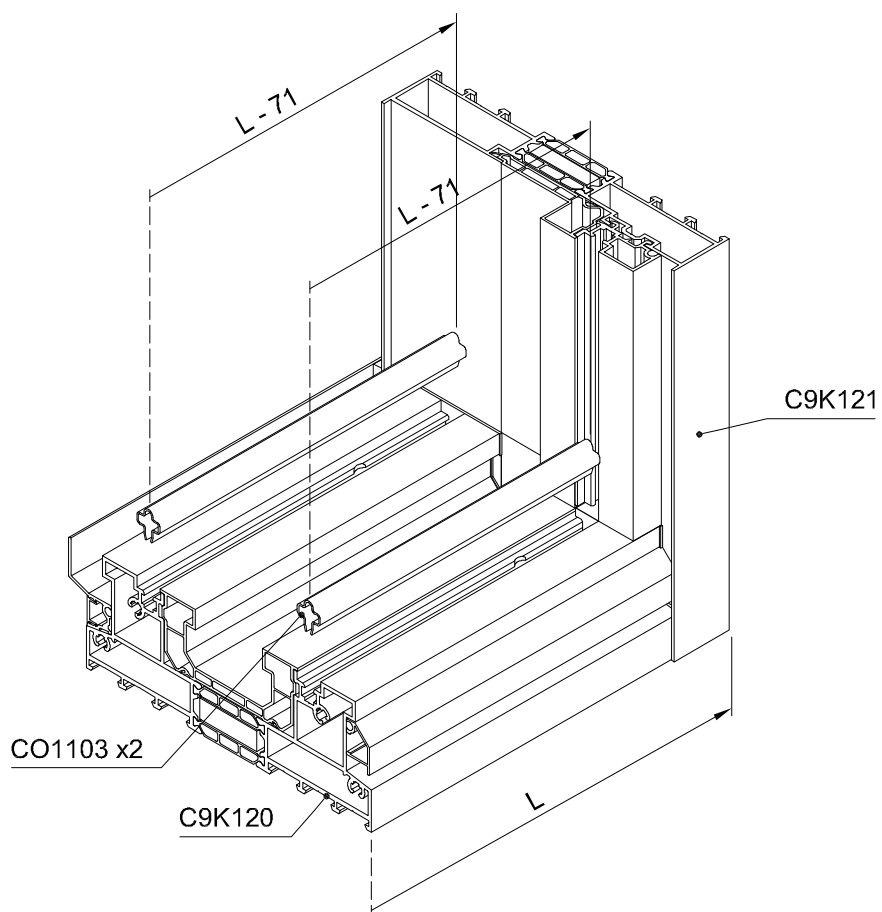
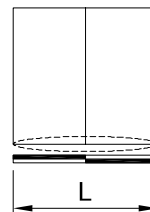

### ASSEMBLAGGIO CO1103 CON 1 ANTA FUNZIONALE

2 / 3

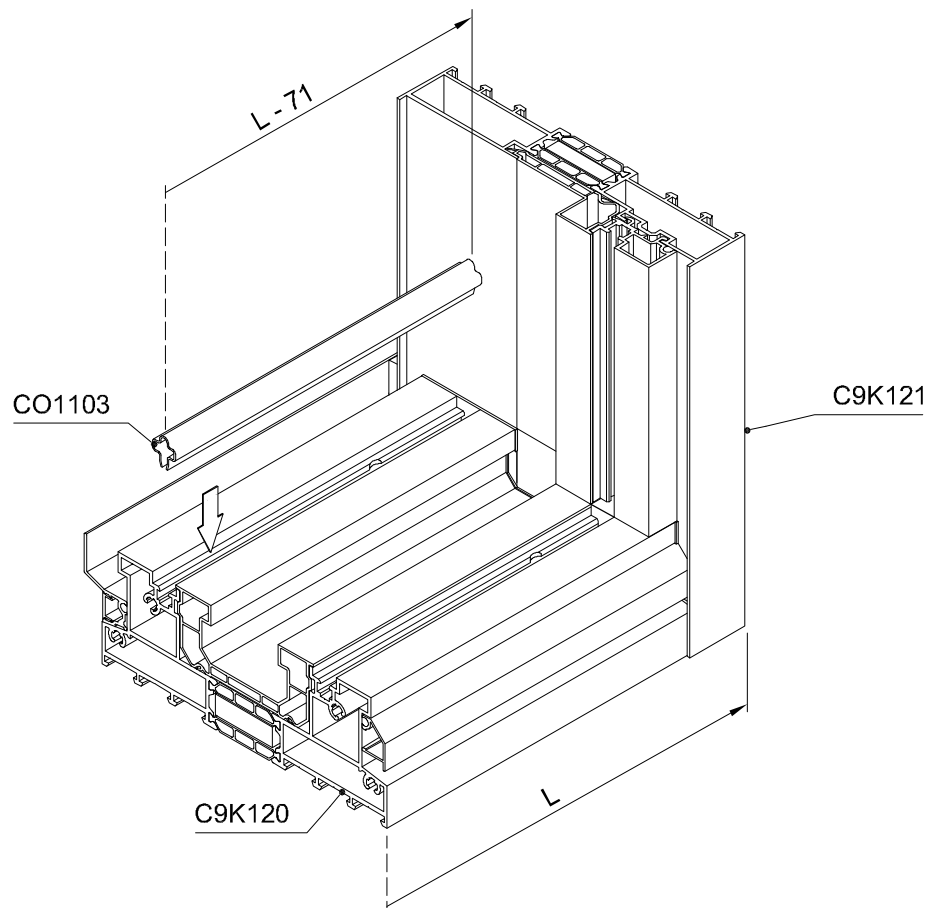
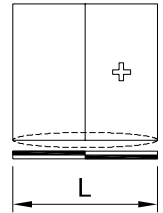

**ASSEMBLAGGIO CO1103 E ZB0038 PER SCHEMA 4 ANTE**

3 / 3

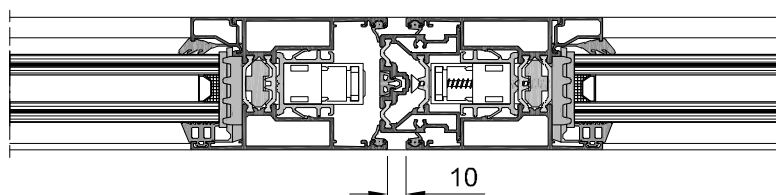
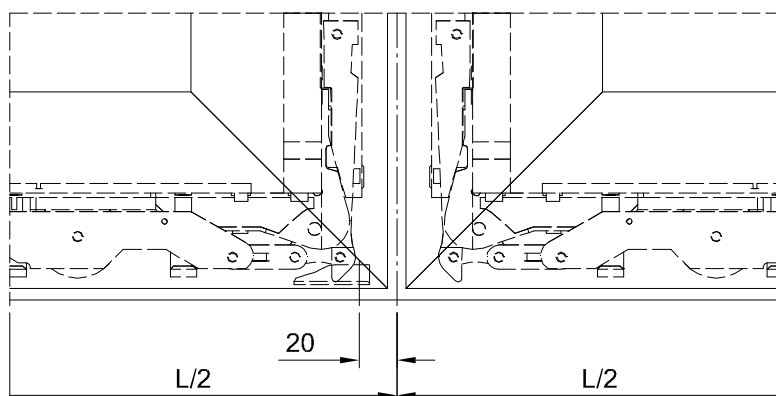
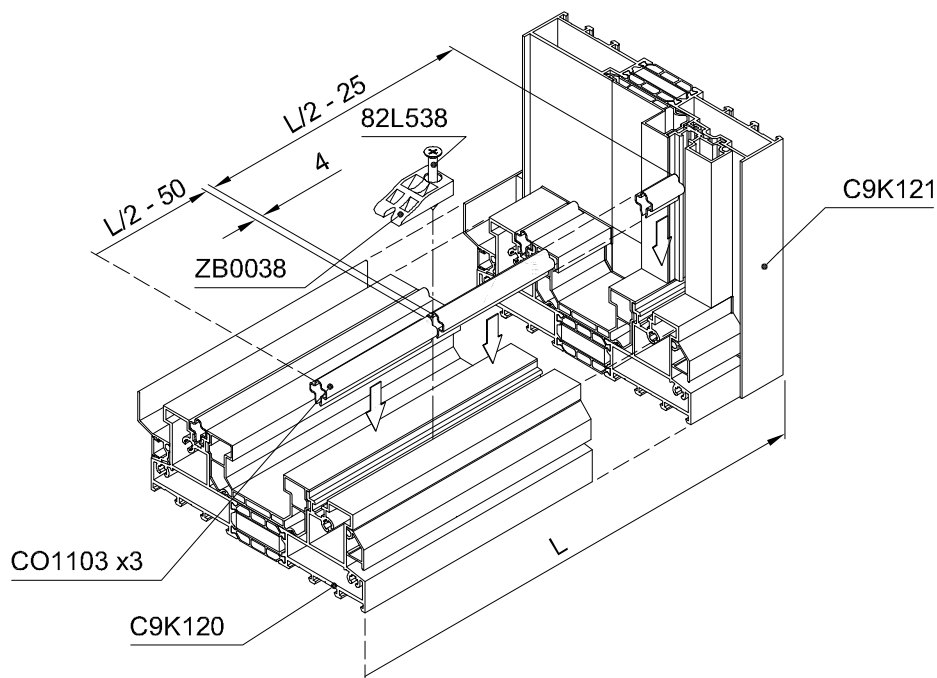
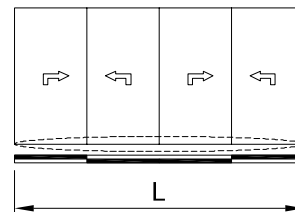



## 2-BINARI TELAIO TAGLI 90°

### ASSEMBLAGGIO PUNTI DI CHIUSURA

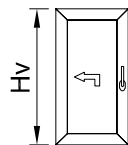
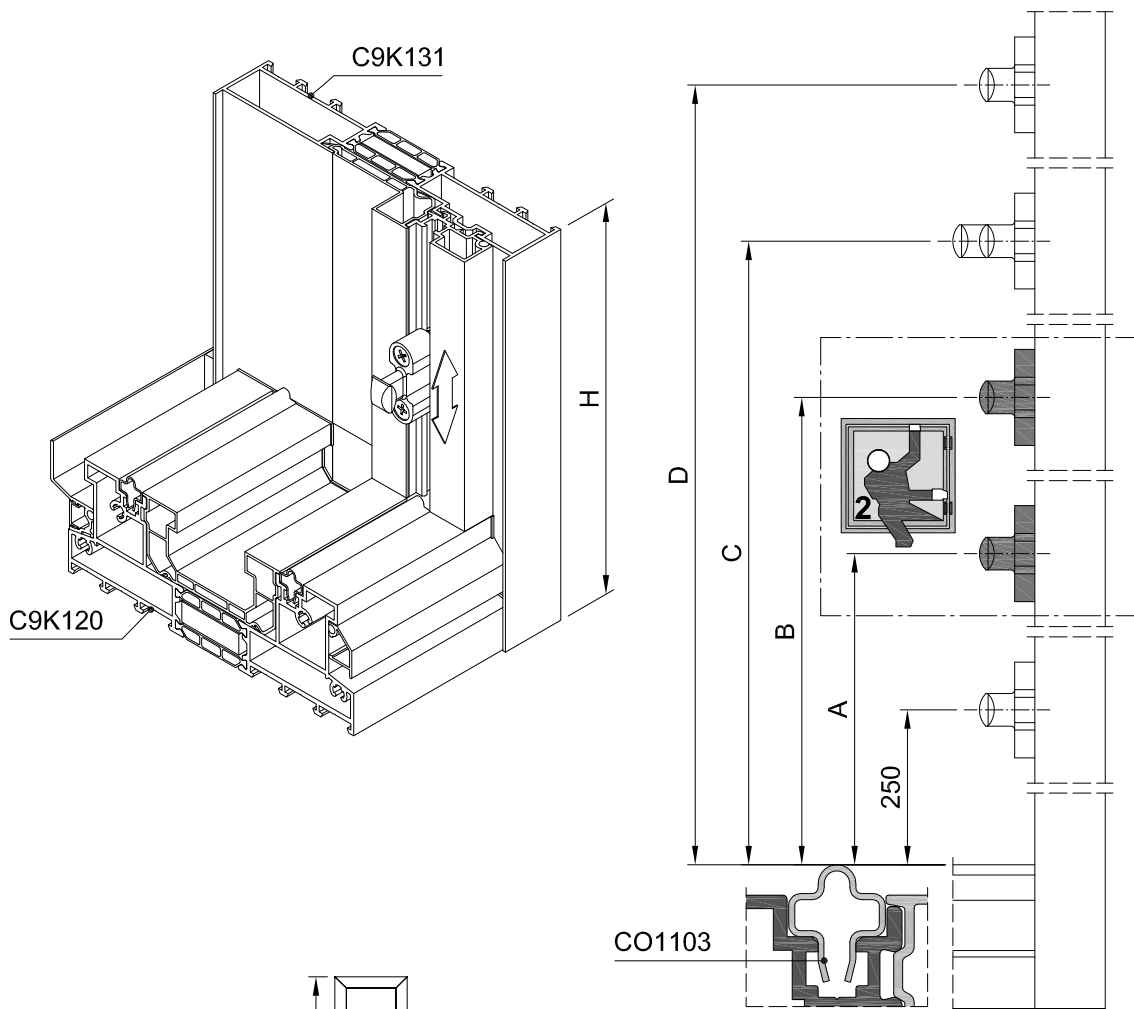
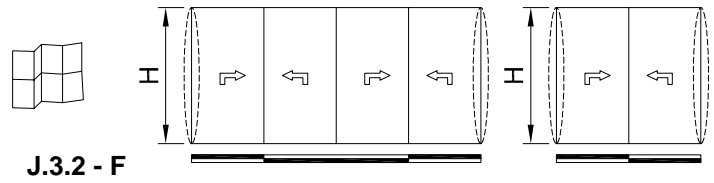

$$H_v = H - 100$$

	Hv		A	B	C	D
	2010 - 2309	ZB0034	750	1200	1600	Hv - 271
	2310 - 2609	ZB0035			1900	
	2610 - 2909	ZB0036			2200	
	2910 - 3209	ZB0035 + ZB0046			1900	
	3210 - 3509	ZB0036 + ZB0046			2200	
	1312 - 2009	ZB0033		600	1000	

**ASSEMBLAGGIO GUARNIZIONE DI FINITURA RU9704**

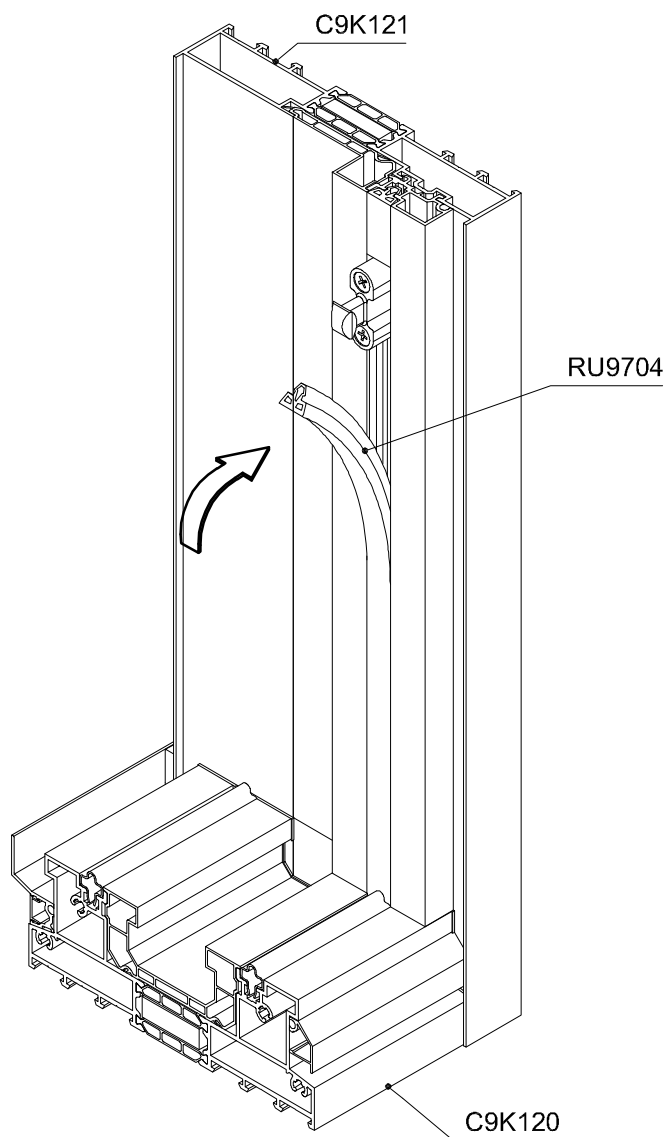
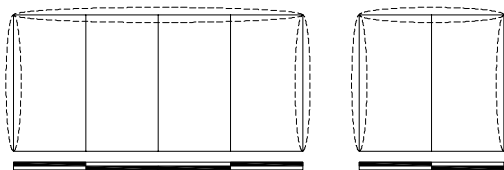

ASSEMBLAGGIO TAPPO CENTRALE CO1105/CO1104 PROFILATO INFERIORE C9K120

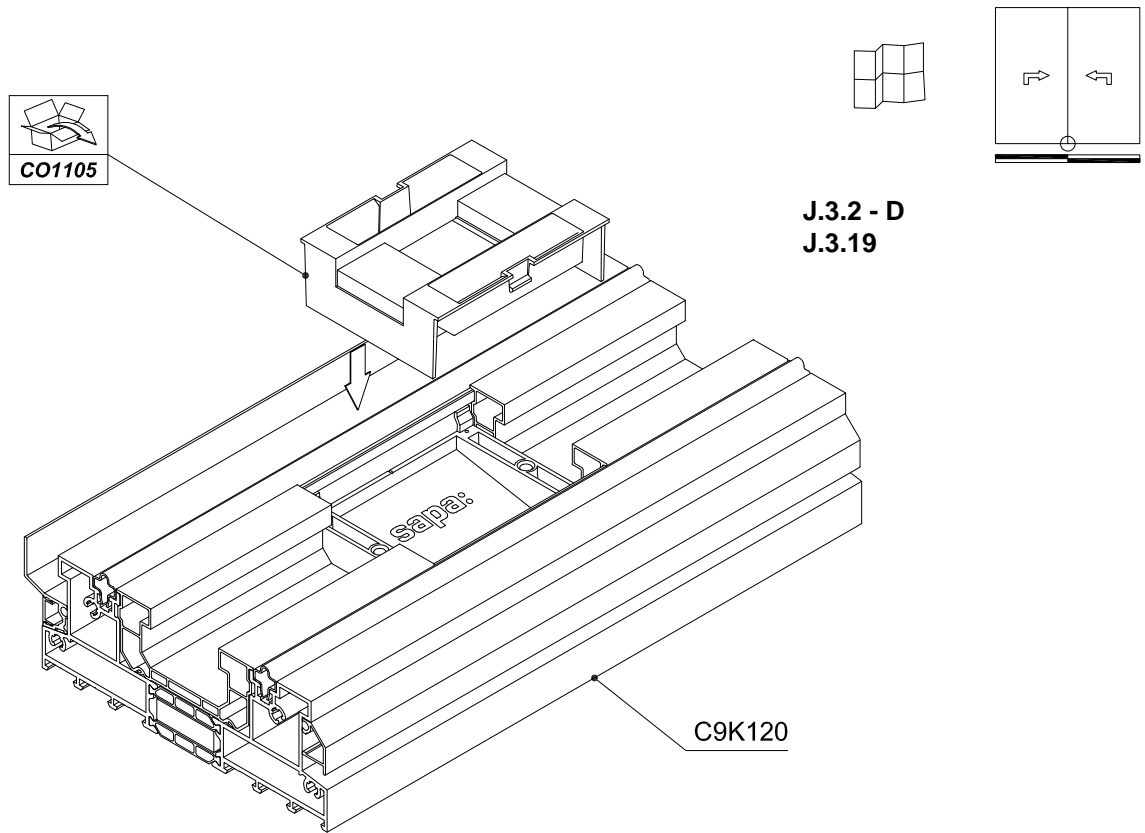



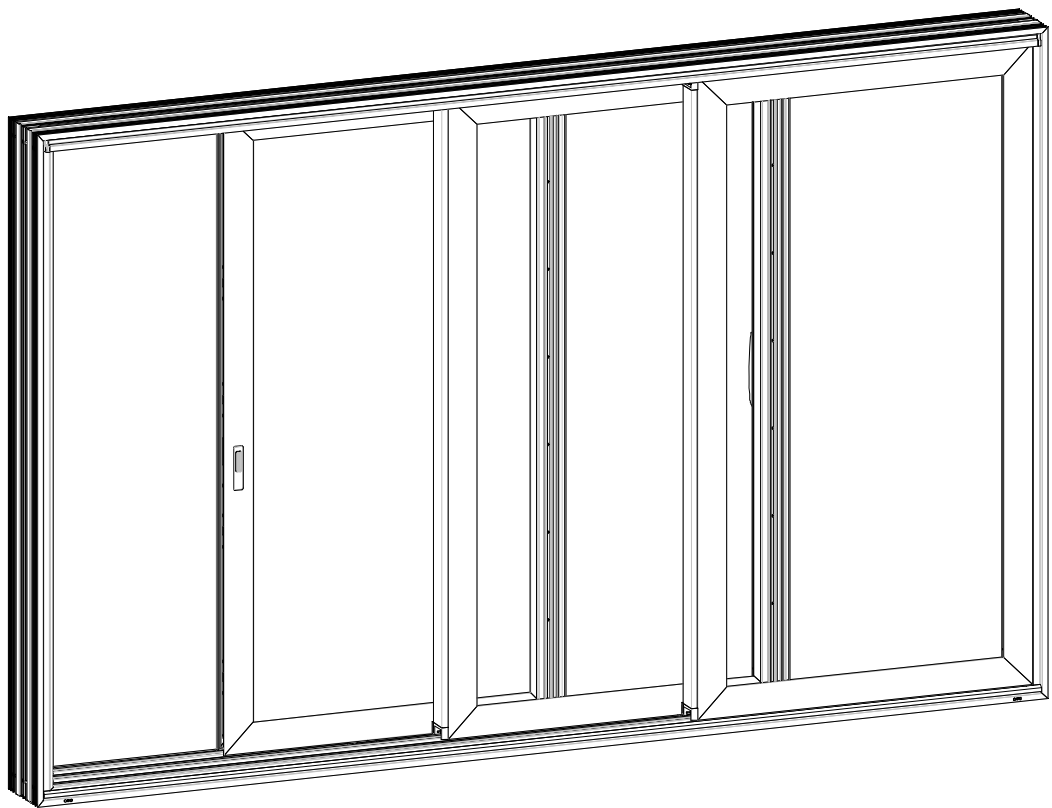

PANORAMICA ASSEMBLAGGIO

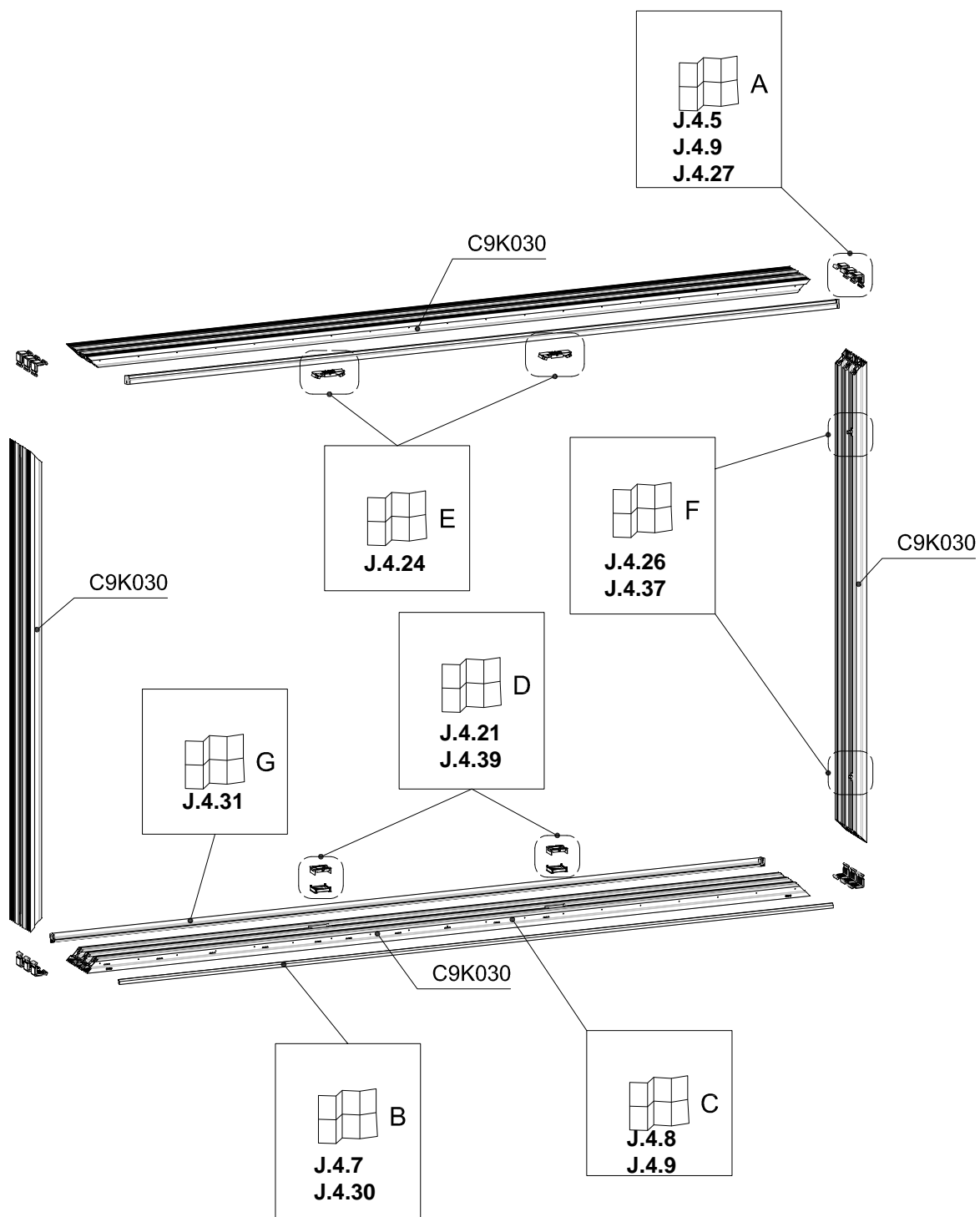

## 3-BINARI TELAIO TAGLI 45°

### CONTENUTO

3-binari telaio tagli 45° .....	J.4.1
Panoramica assemblaggio .....	J.4.2
Contenuto .....	J.4.3



Operazioni C9K030 + KU2028 e assemblaggio BT6006 .....	J.4.4
Operazioni squadrette per C9K030 .....	J.4.5



Operazioni C9K030 per cappetta di drenaggio C9A003 .....	J.4.7
C9K030 panoramica drenaggi .....	J.4.8
KU2028 panoramica drenaggi .....	J.4.9
C9K030 lavorazione drenaggio - J .....	J.4.10
C9K030 lavorazione drenaggio - H1, H2 .....	J.4.11
C9K030 lavorazione drenaggio - B, D .....	J.4.12
C9K030 lavorazione drenaggio - A, C .....	J.4.13
C9K030 lavorazione drenaggio - G .....	J.4.14
C9K030 lavorazione drenaggio - M .....	J.4.15
KU2028 lavorazione drenaggio - K1, K2 .....	J.4.16
KU2028 lavorazione drenaggio - K3 .....	J.4.17
KU2028 lavorazione drenaggio - K4 .....	J.4.18
KU2028 lavorazione drenaggio - K5 .....	J.4.19



Assemblaggio VS0107 e KU2028 su C9K020 profilato inferiore .....	J.4.20
Assemblaggio tappo centrale CO1105 profilato inferiore C9K030 .....	J.4.21
Assemblaggio tappo centrale CO1105/CO1104 profilato inferiore C9K030 .....	J.4.22
Sigillatura profilato inferiore C9K030 con VS9950/VS9951/VS9964 e VS9965 .....	J.4.23
Assemblaggio tappo centrale CO1111 profilato superiore C9K030 .....	J.4.24



Assemblaggio profilati telai con squadrette .....	J.4.27
Assemblaggio cappetta di drenaggio C9A003 .....	J.4.30
Operazioni C9A004 + VS2404 .....	J.4.31
Assemblaggio C9A004 + VS2404 .....	J.4.32
Assemblaggio C9A004 + VS2404 - optional .....	J.4.33
Assemblaggio guida CO1103 .....	J.4.34
Assemblaggio guida CO1103 per fisso-scorrevole-fisso .....	J.4.35
Assemblaggio guida CO1103 e ZB0038 per schema 4 ante .....	J.4.36
Assemblaggio punti di chiusura .....	J.4.37
Assemblaggio guarnizione di finitura RU9704 .....	J.4.38
Assemblaggio tappo centrale CO1105/CO1104 profilato inferiore C9K030 .....	J.4.39

**OPERAZIONI C9K030 + KU2028 E ASSEMBLAGGIO BT6006**

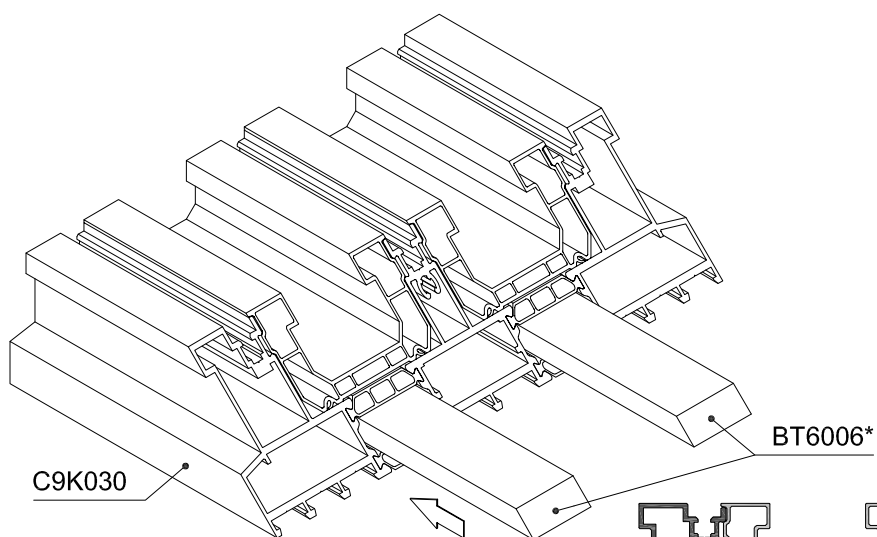
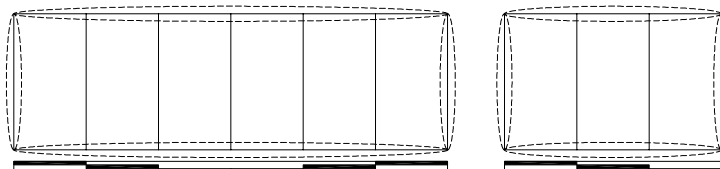
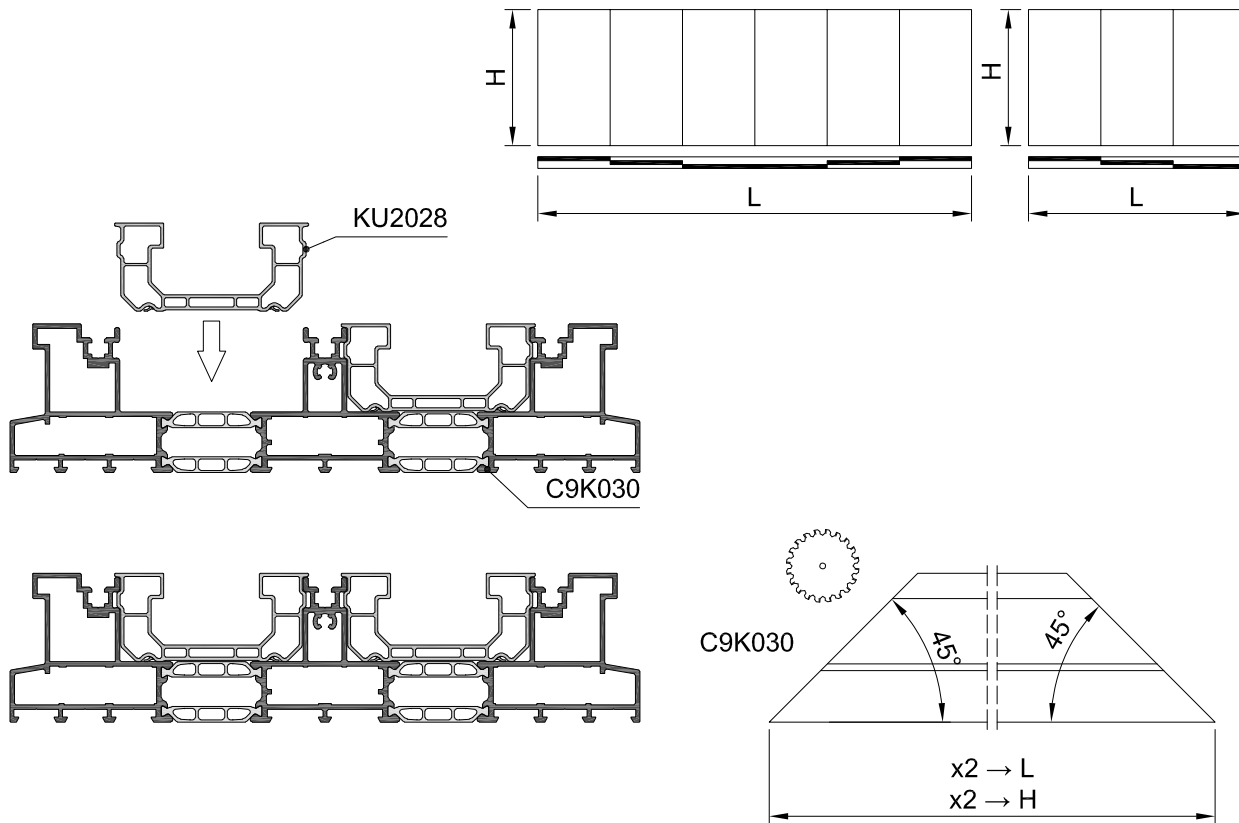

	BT6006
SHI	✓
SI	✓
I	x

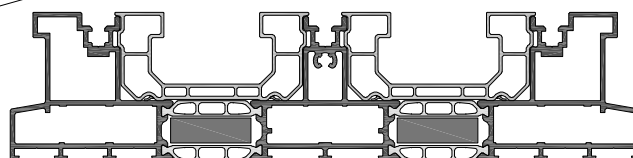



## 3-BINARI TELAIO TAGLI 45°

### OPERAZIONI SQUADRETTE PER C9K030

1 / 2

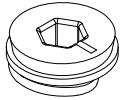

778-500



J.4.2 - A  
J.4.27

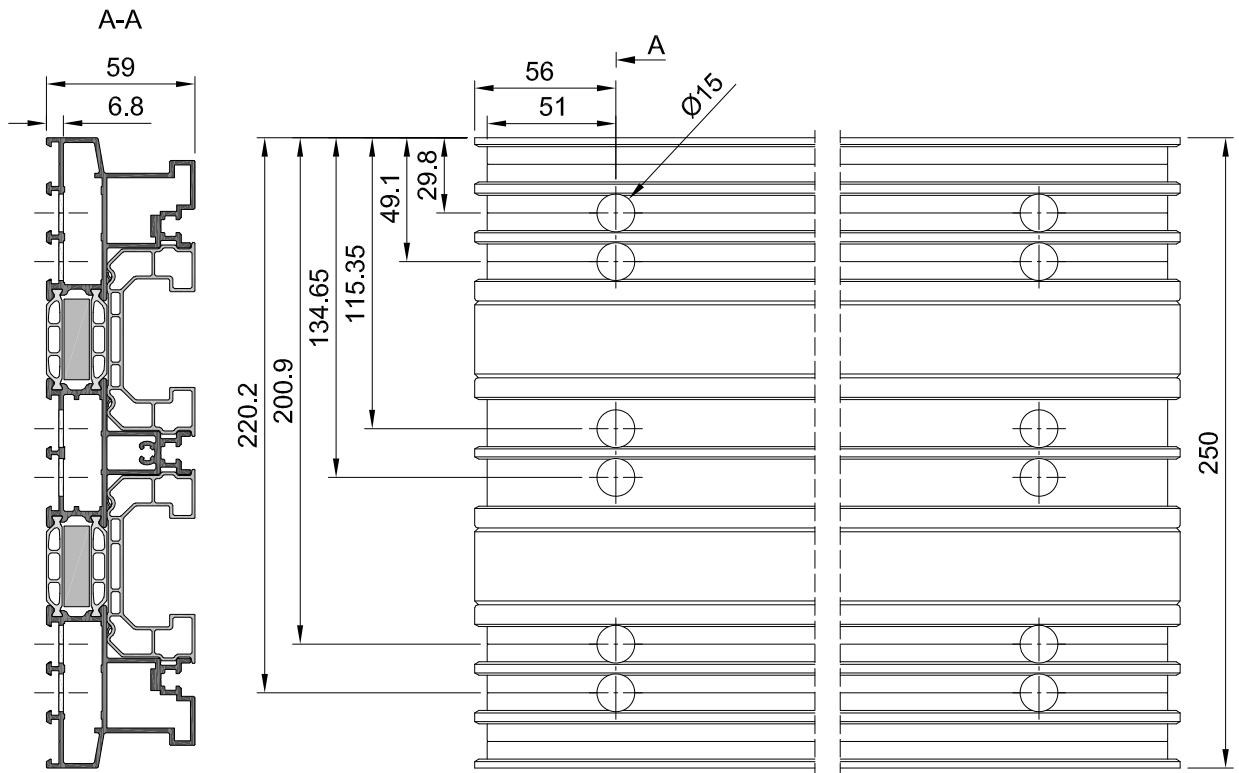
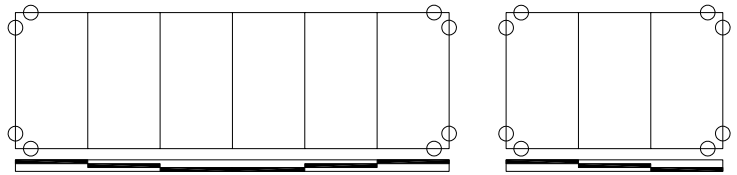

C9K030

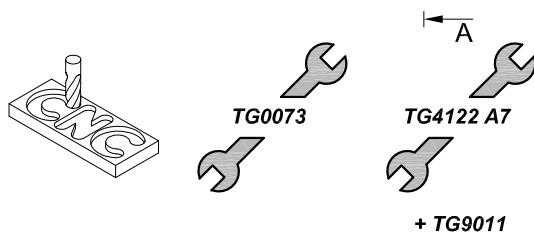



## 3-BINARI TELAIO TAGLI 45°

### OPERAZIONI C9K030 PER CAPPETTA DI DRENAGGIO C9A003



J.4.2 - B  
J.4.30

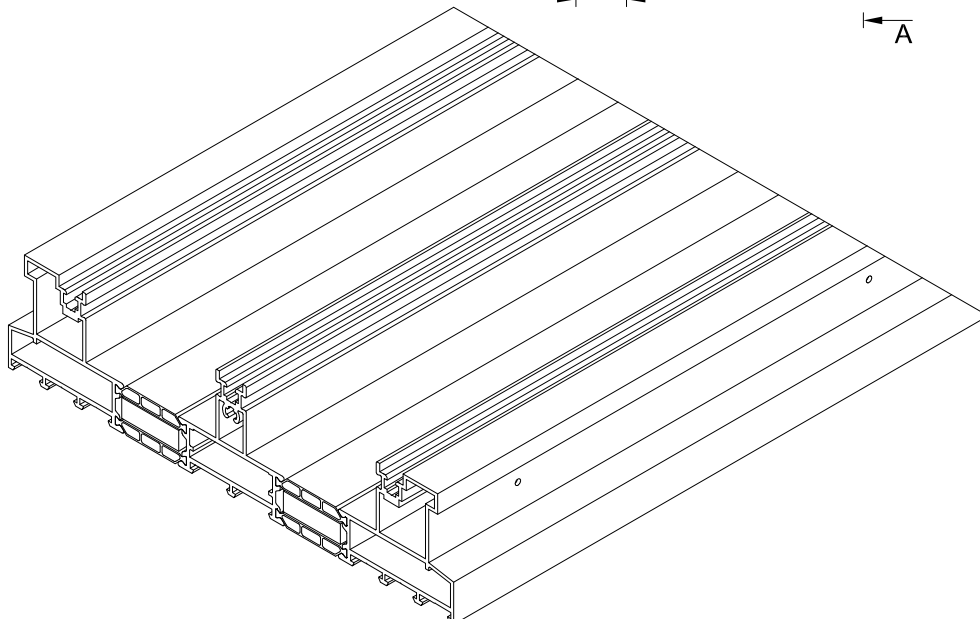
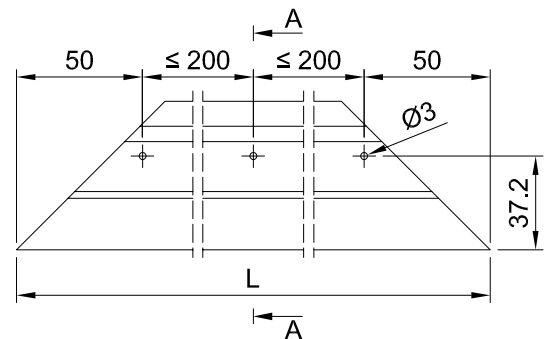
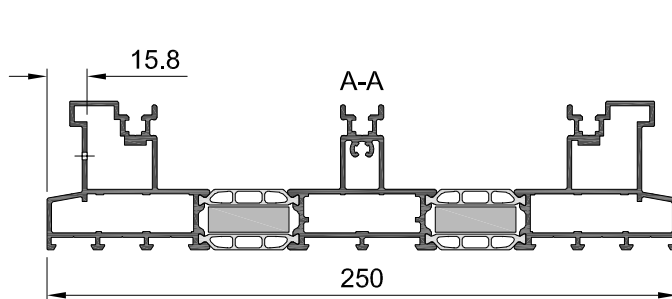
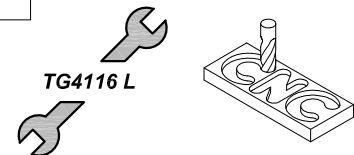
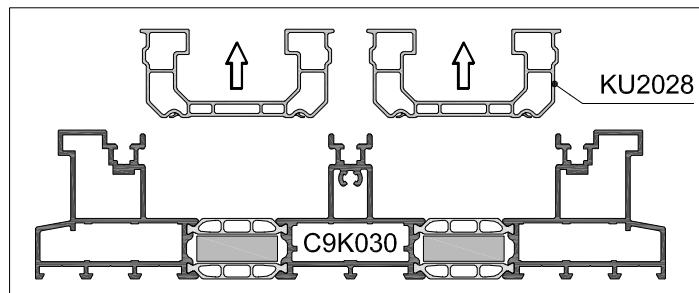
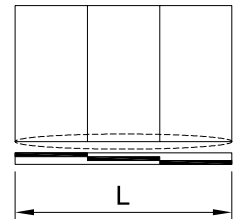
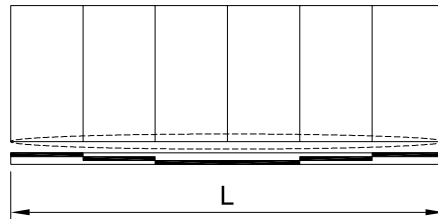

**C9K030 PANORAMICA DRENAGGI**

1 / 13

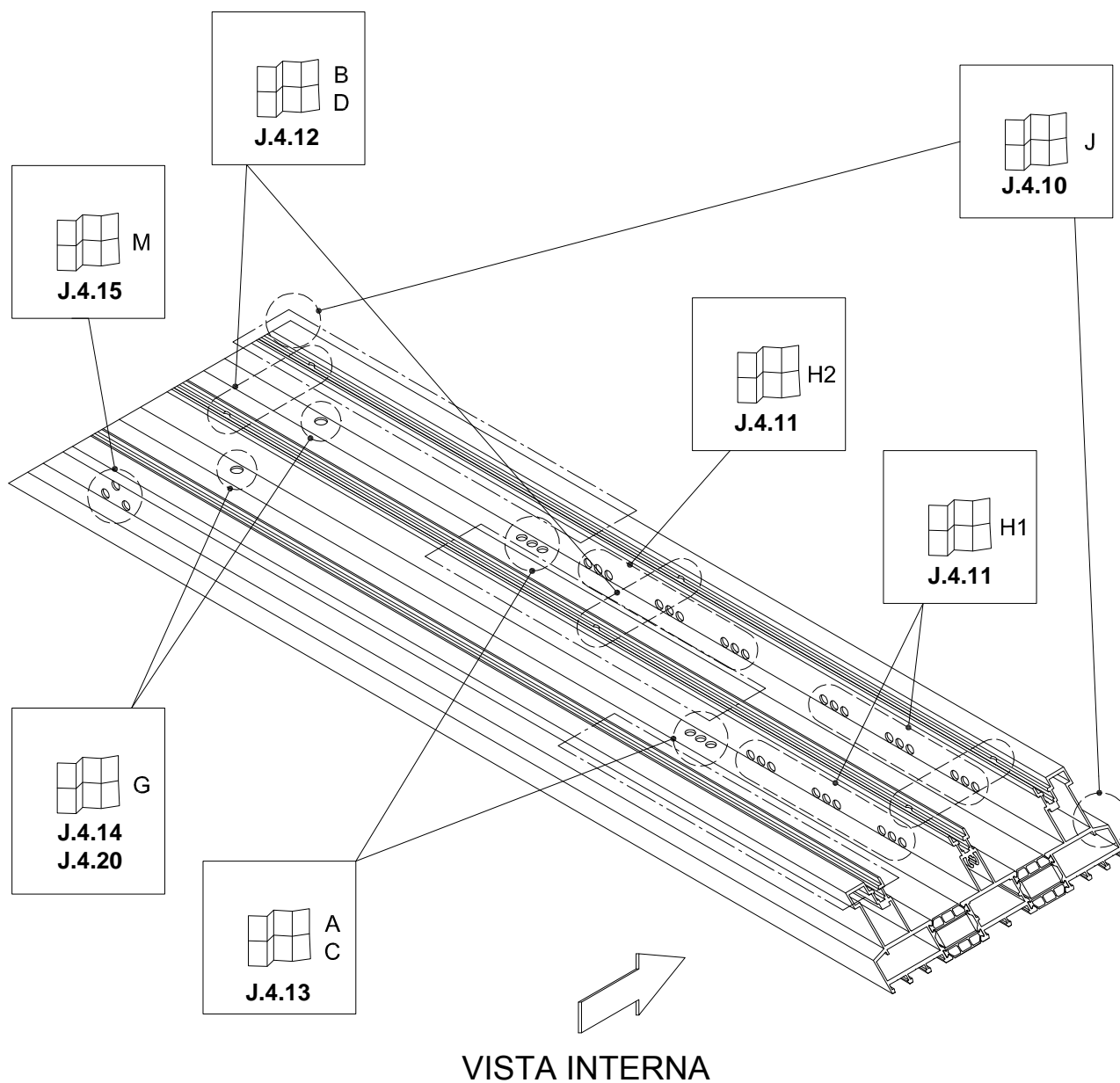
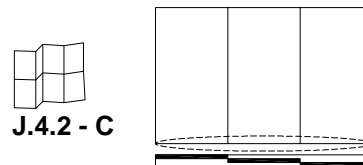

### KU2028 PANORAMICA DRENAGGI

2 / 13

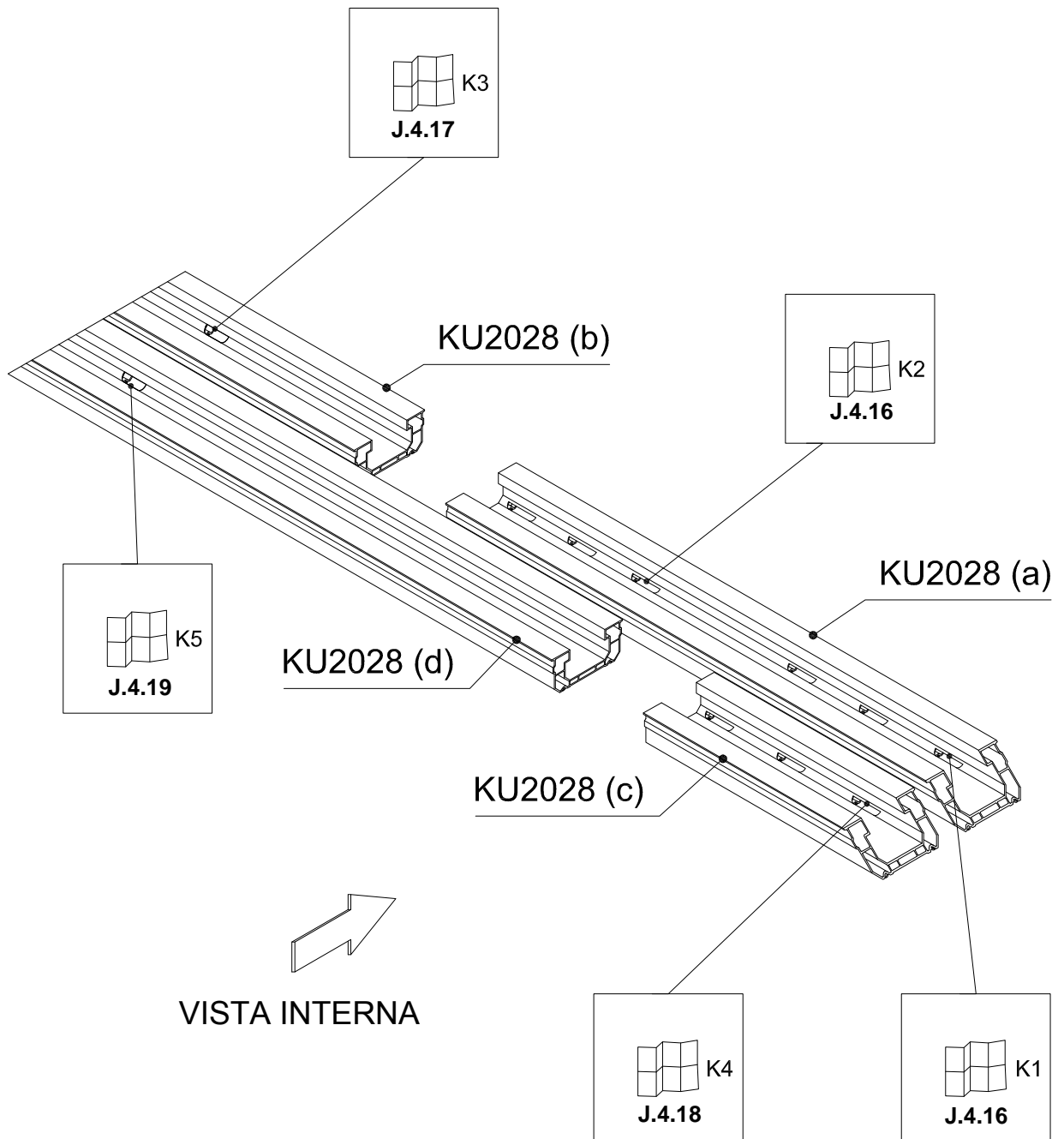
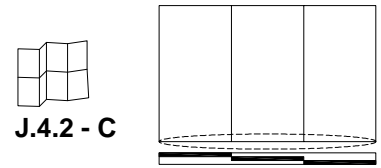

**C9K030 LAVORAZIONE DRENAGGIO - J**

3 / 13



J.4.8 - J

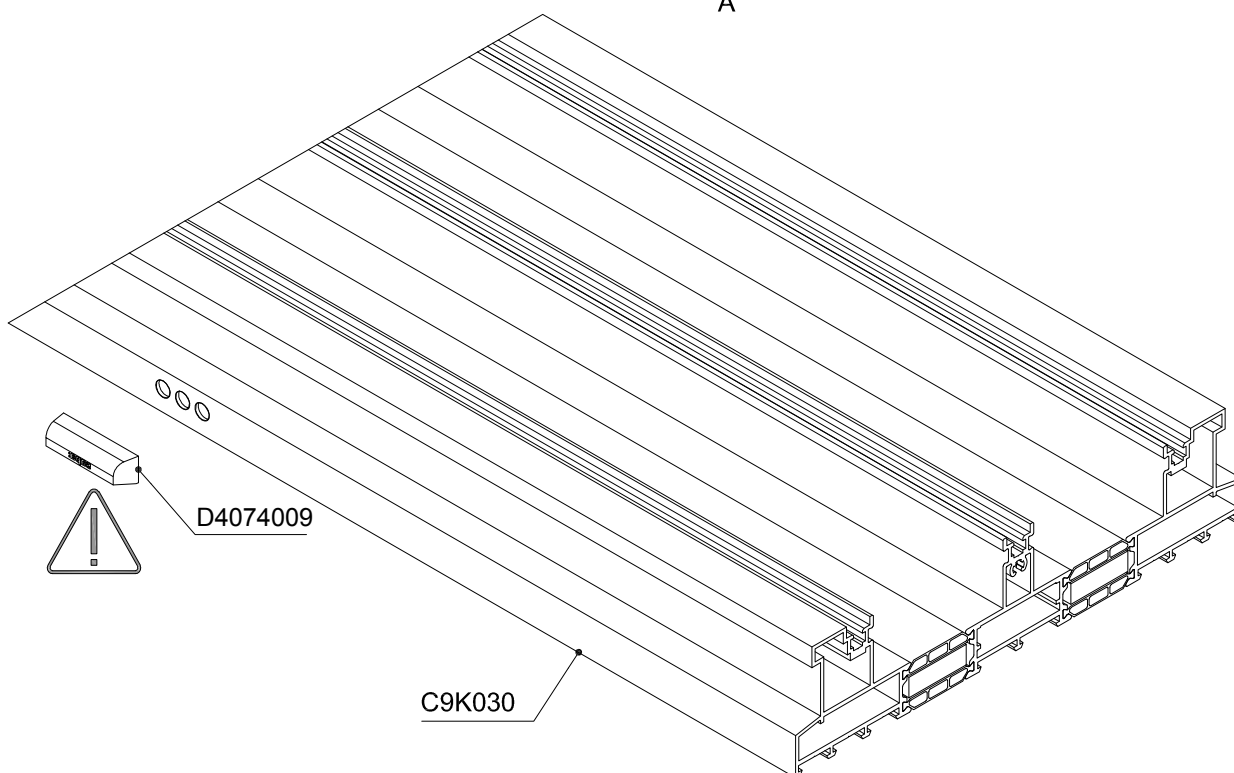
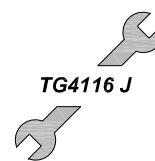
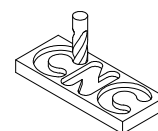
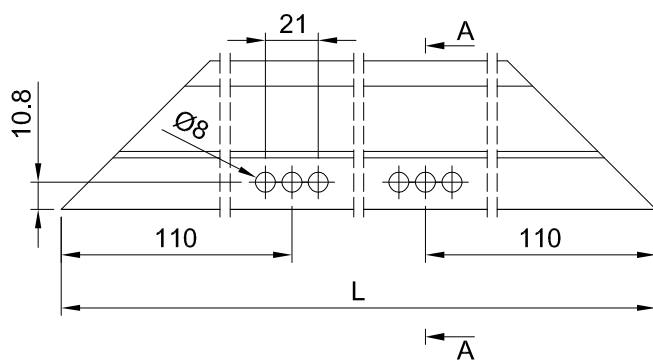
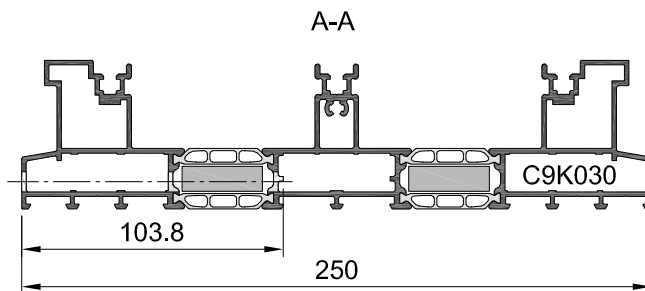
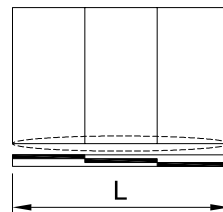

## 3-BINARI TELAIO TAGLI 45°

### C9K030 LAVORAZIONE DRENAGGIO - H1, H2

4 / 13



J.4.8 - H1, H2  
X → J.1.4

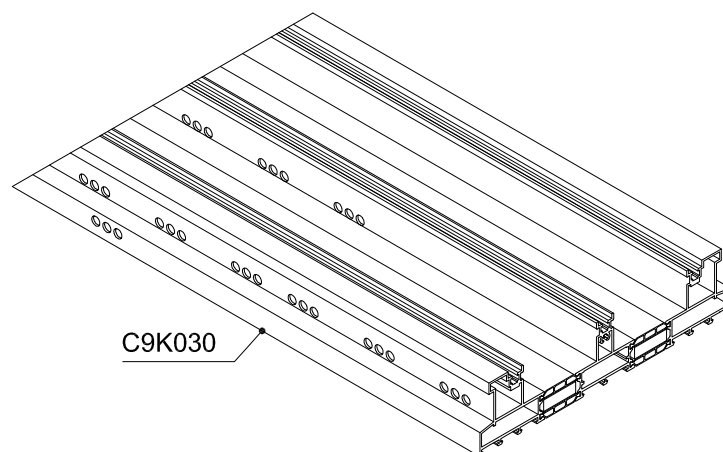
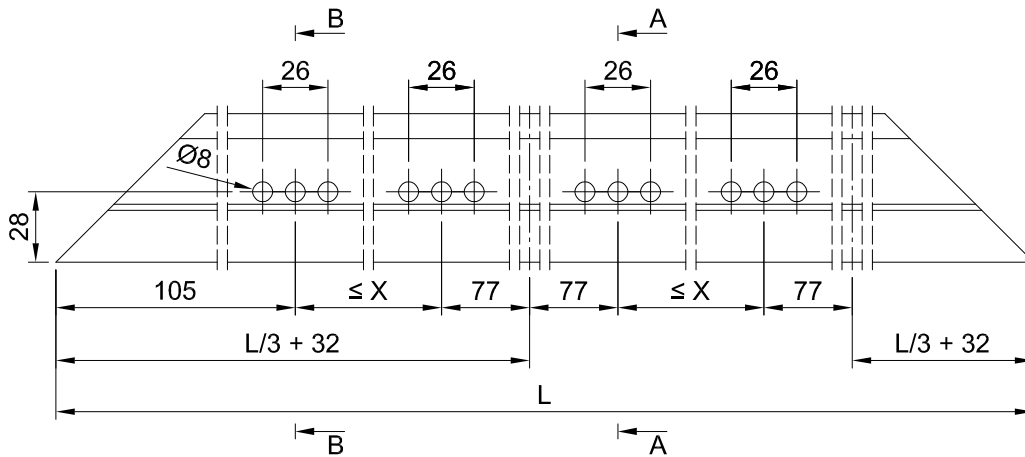
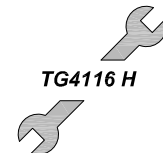
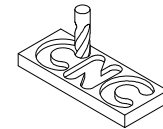
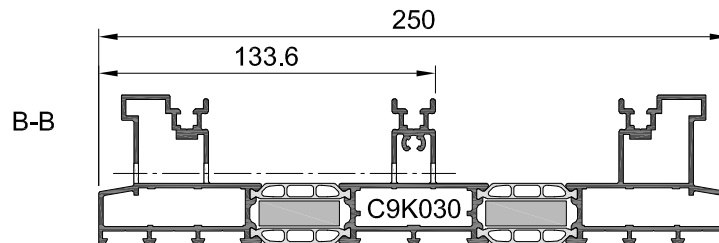
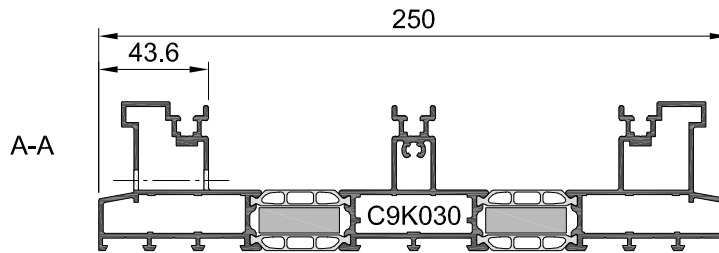
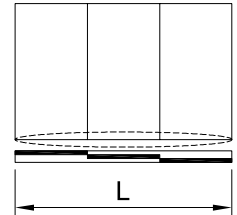

**3-BINARI TELAIO TAGLI 45°**

**C9K030 LAVORAZIONE DRENAGGIO - B, D**

5 / 13



J.4.8 - B, D

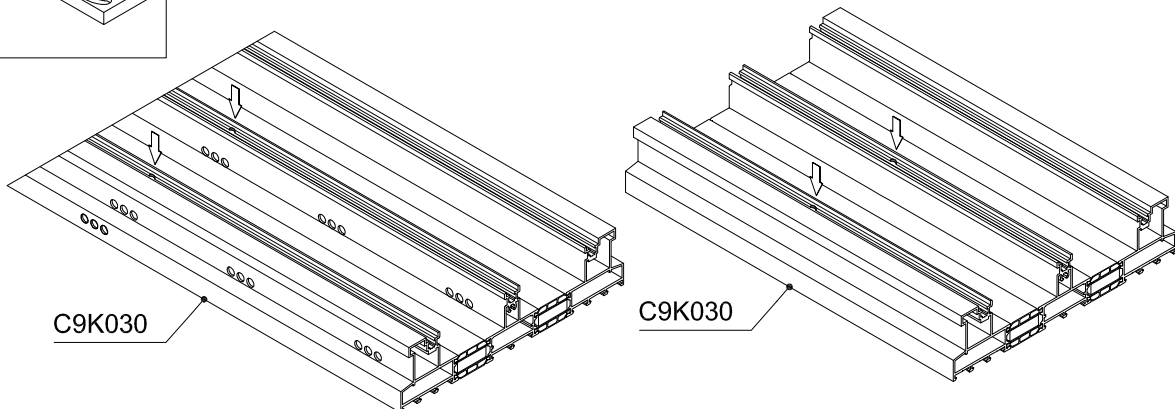
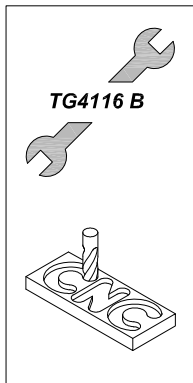
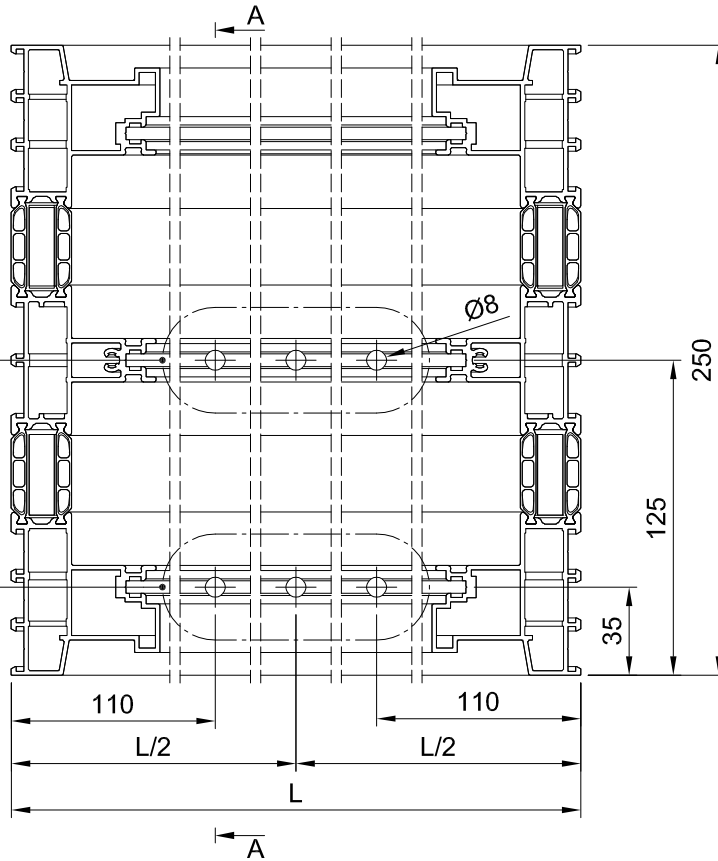
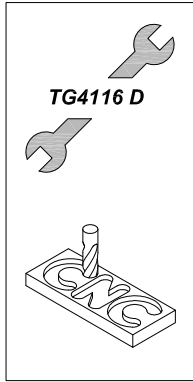
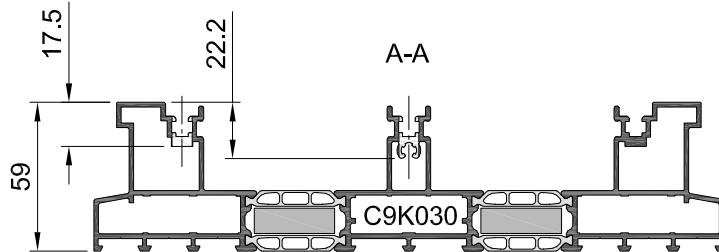
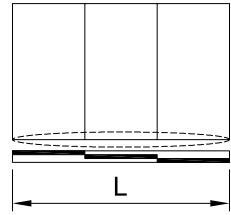

 **C160-ASS-1212**



3-BINARI TELAIO TAGLI 45°

C9K030 LAVORAZIONE DRENAGGIO - A, C

6 / 13



J.4.8 - A, C

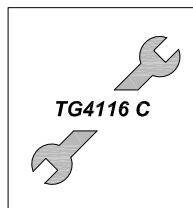
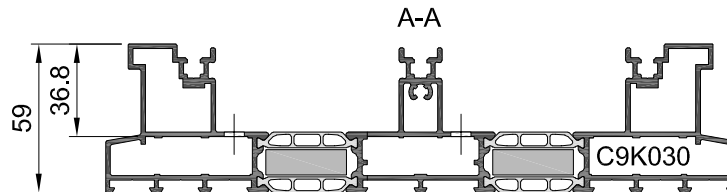
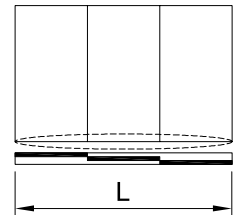

TG4116 C

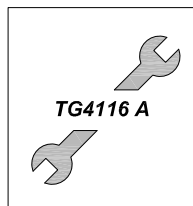

TG4116 A

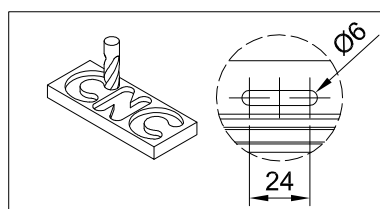
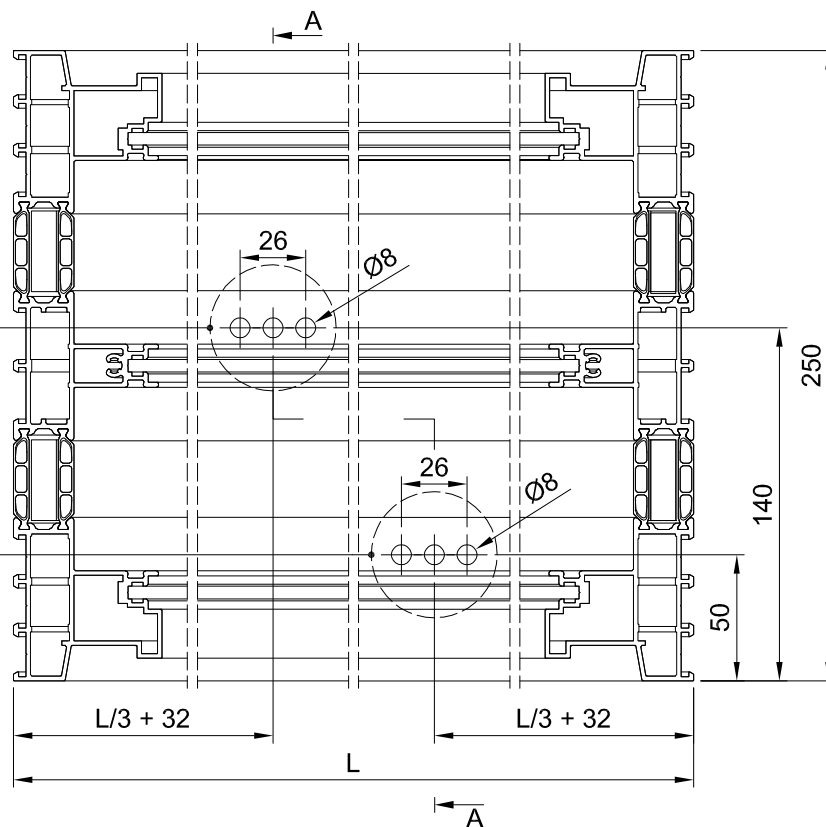

**C9K030 LAVORAZIONE DRENAGGIO - G**

7 / 13



J.4.8 - G  
J.4.20

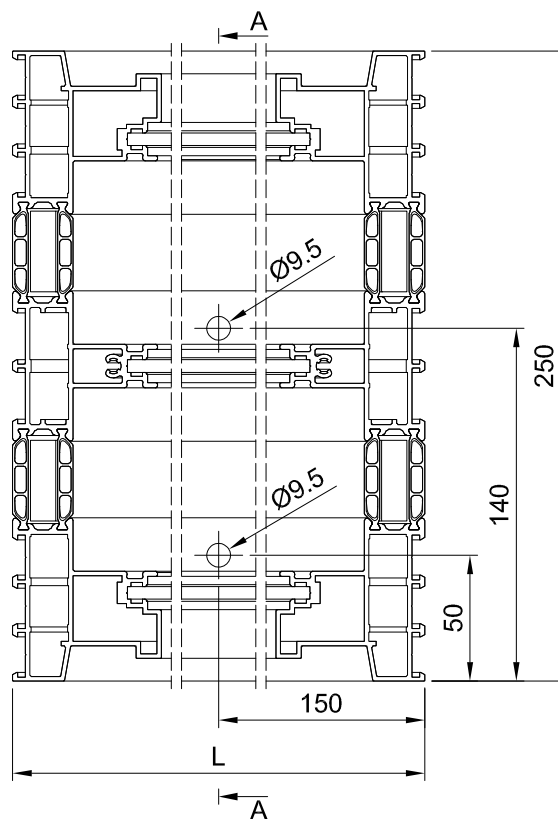
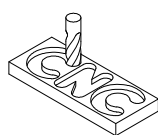
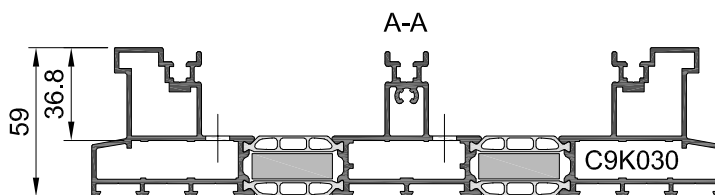
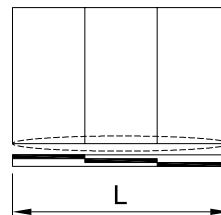

## 3-BINARI TELAIO TAGLI 45°

### C9K030 LAVORAZIONE DRENAGGIO - M

8 / 13

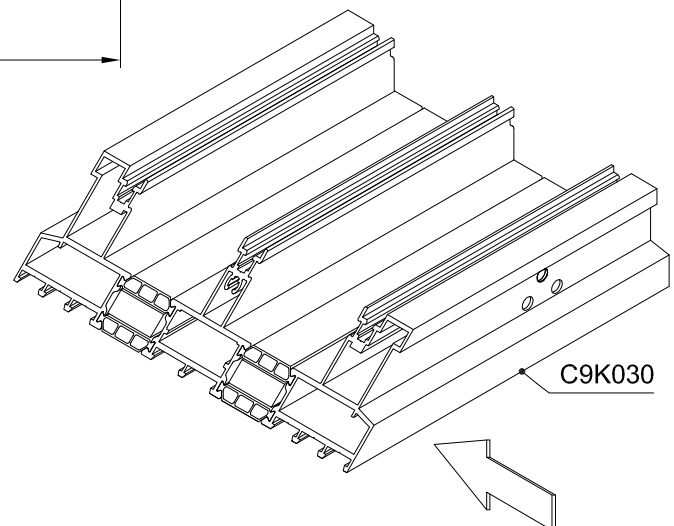
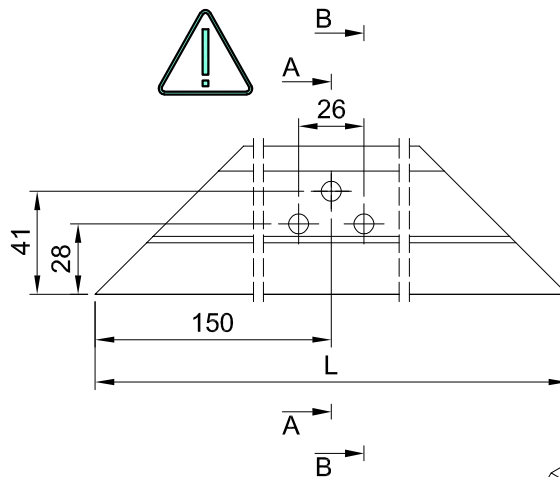
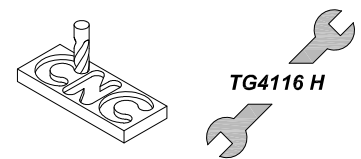
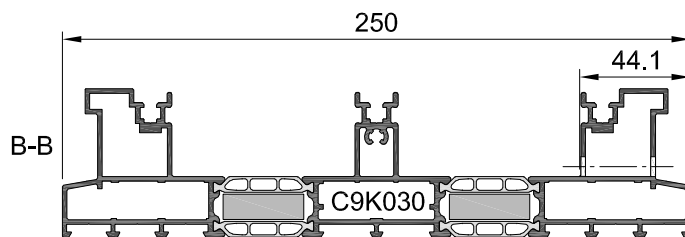
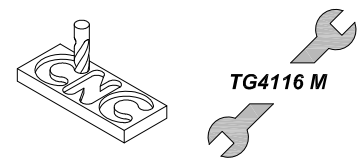
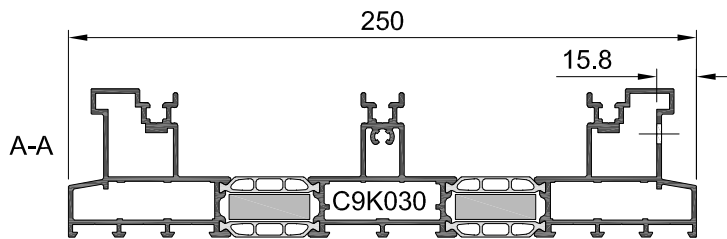
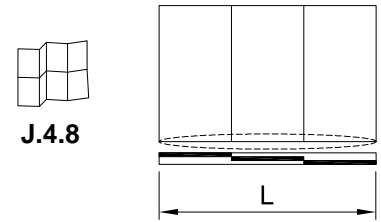

VISTA INTERNA

**KU2028 LAVORAZIONE DRENAGGIO - K1, K2**

9 / 13

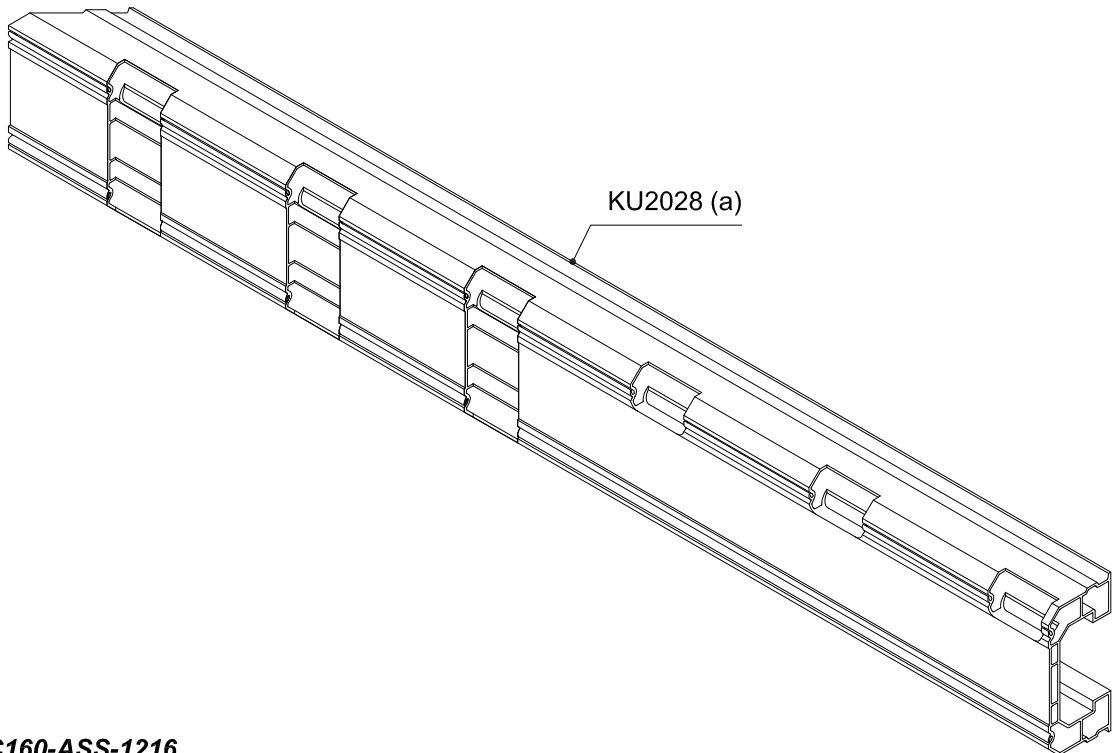
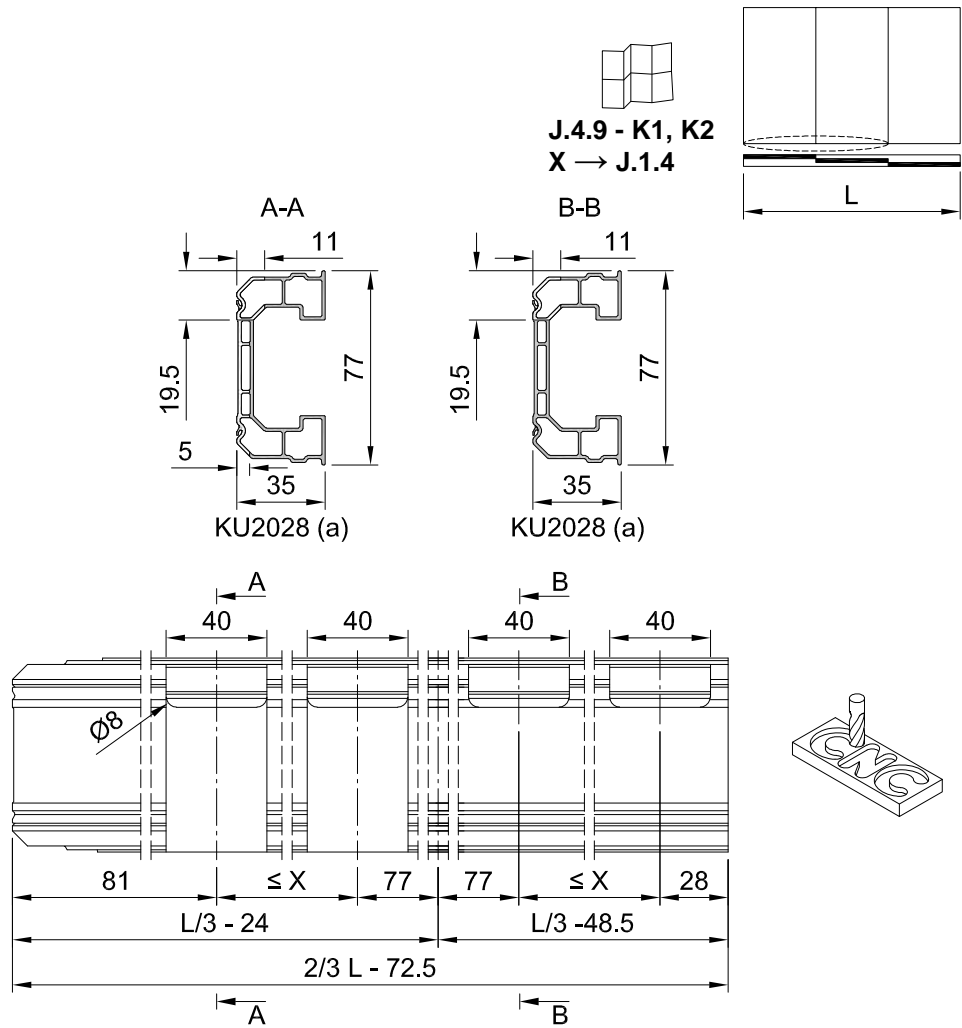

KU2028 LAVORAZIONE DRENAGGIO - K3

10 / 13

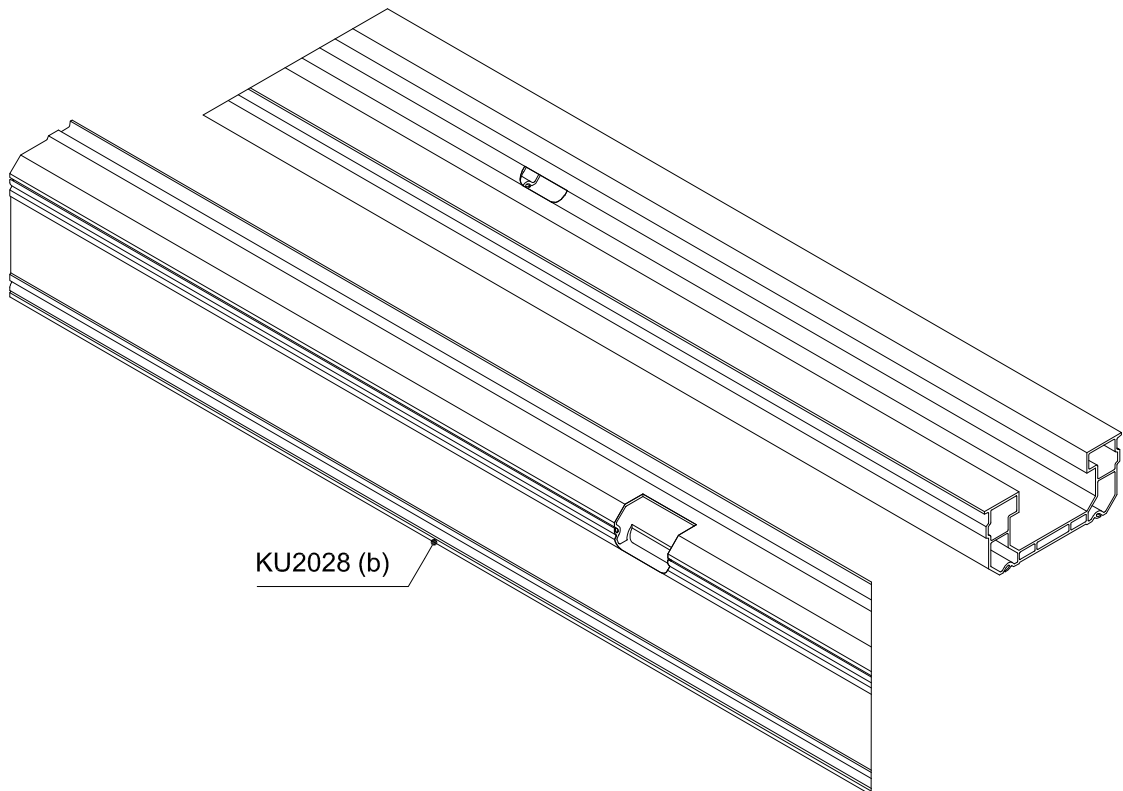
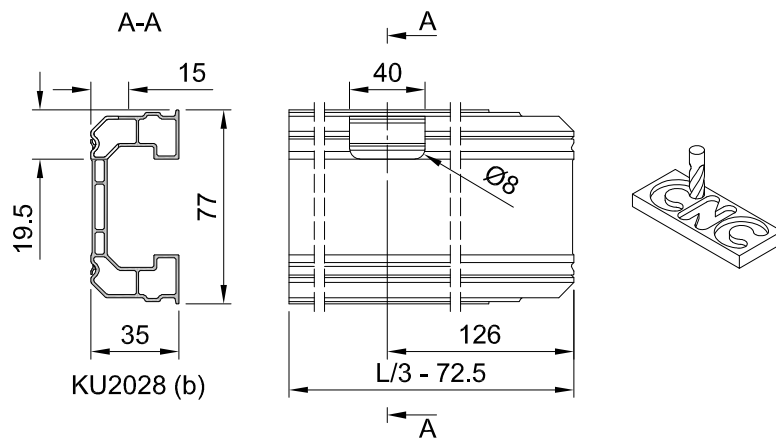
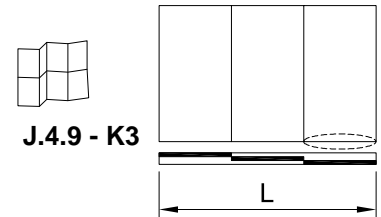

**KU2028 LAVORAZIONE DRENAGGIO - K4**

11 / 13



**J.4.9 - K4**  
**X → J.1.4**

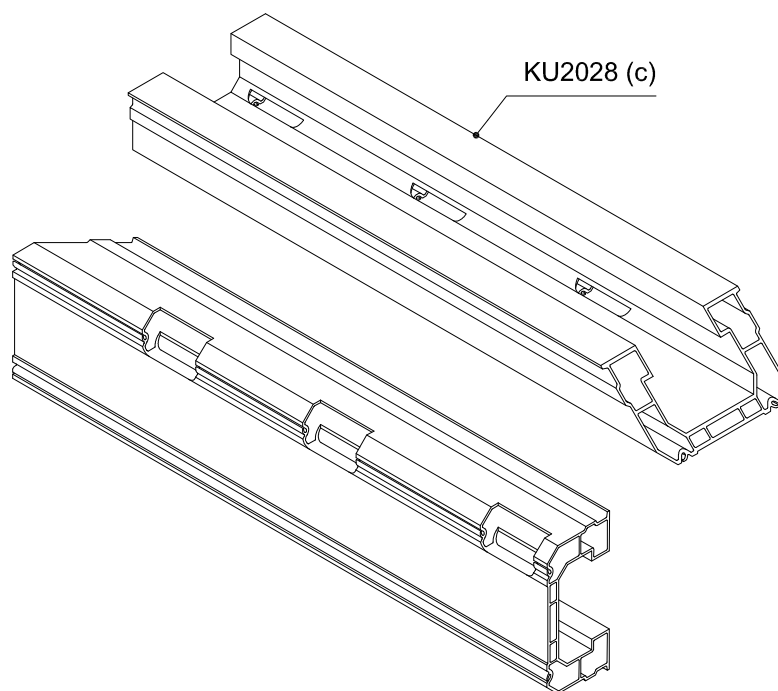
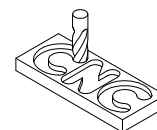
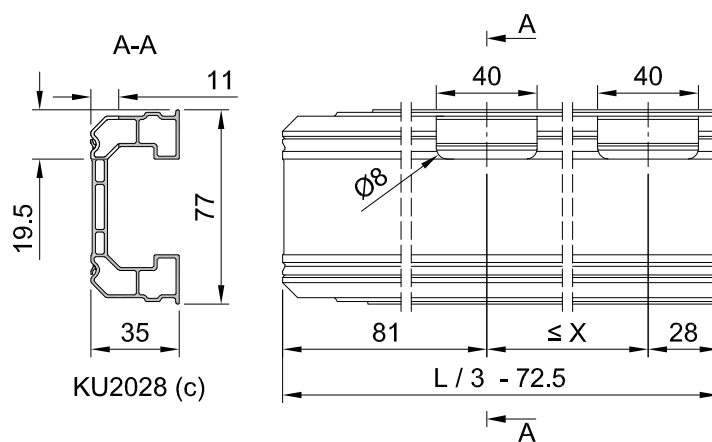
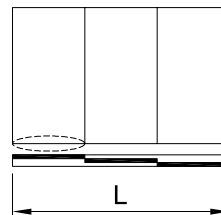

KU2028 LAVORAZIONE DRENAGGIO - K5

12 / 13

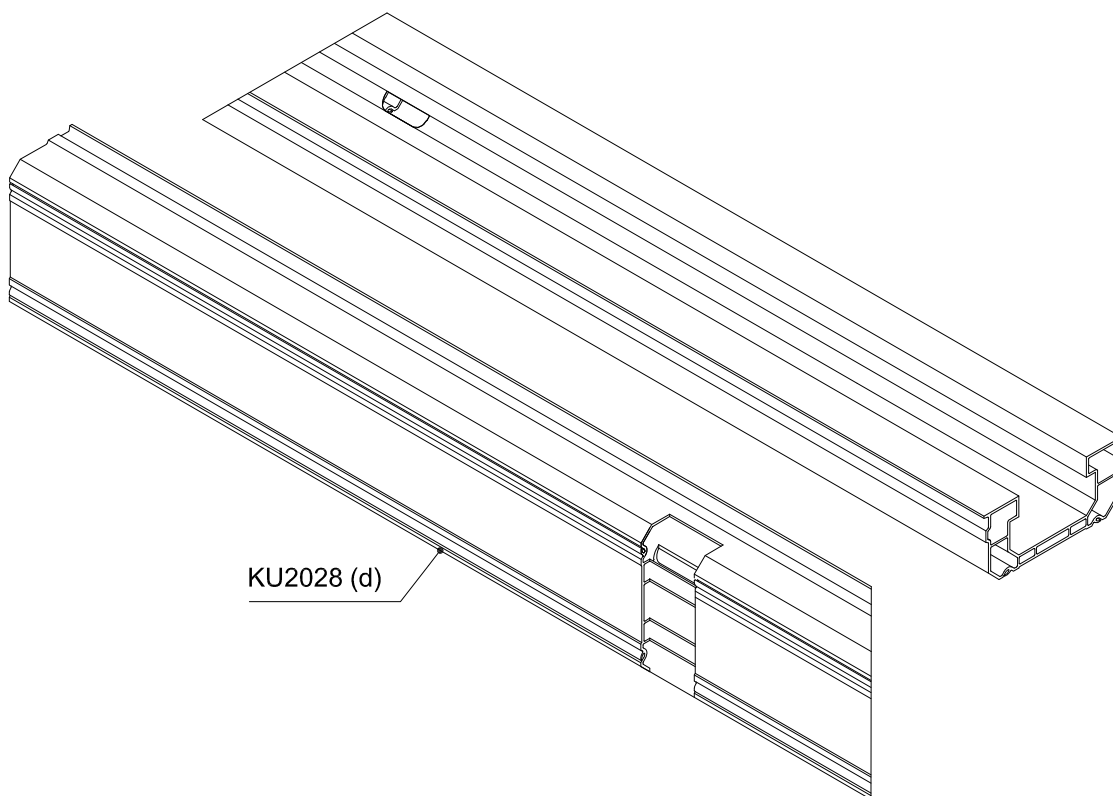
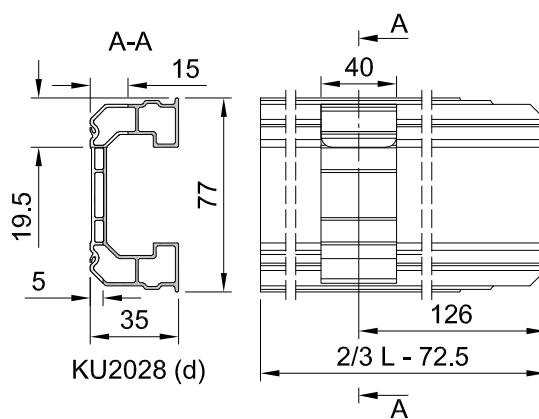
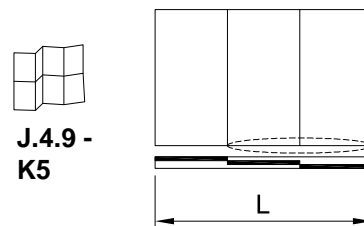

**ASSEMBLAGGIO VS0107 E KU2028 SU C9K020 PROFILATO INFERIORE**

13 / 13

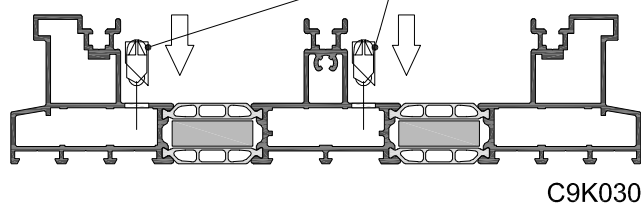
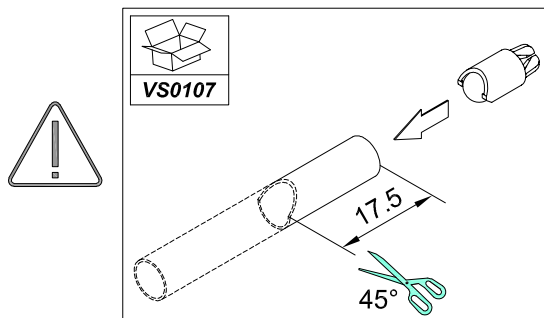
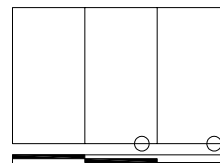

J.4.8 - G  
J.4.14

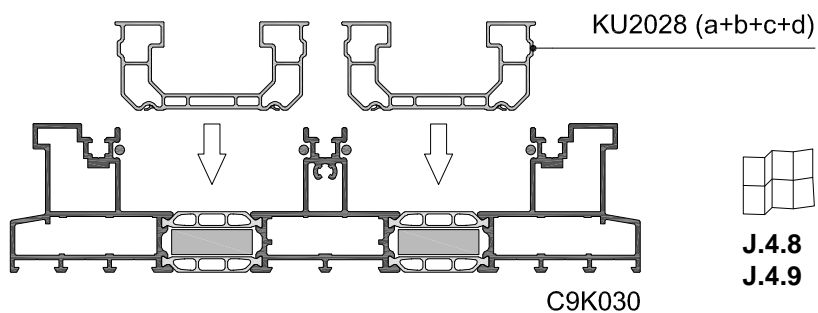
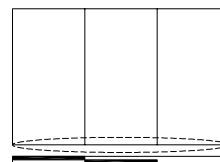
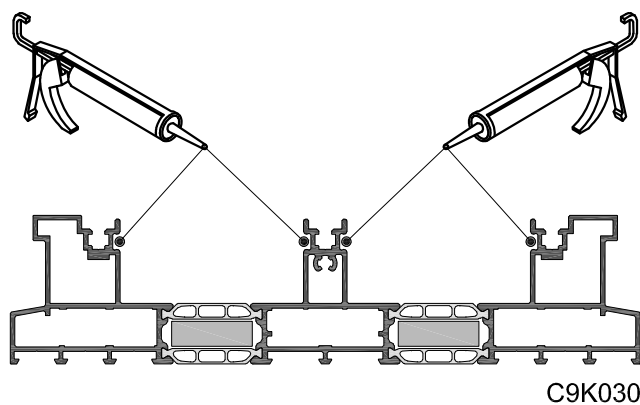

J.4.8  
J.4.9



3-BINARI TELAIO TAGLI 45°

ASSEMBLAGGIO TAPPO CENTRALE CO1105 PROFILATO INFERIORE C9K030

1 / 2

J.4.2 - D  
J.4.39

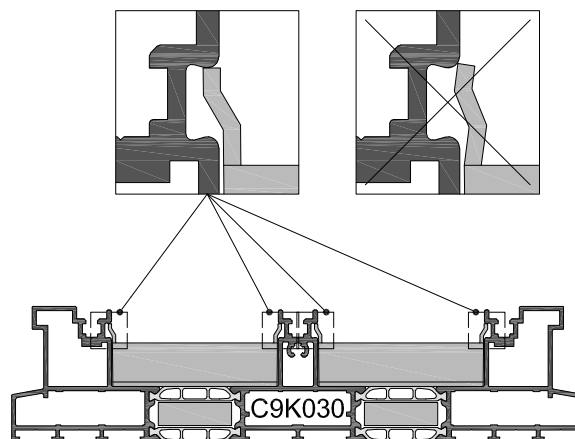
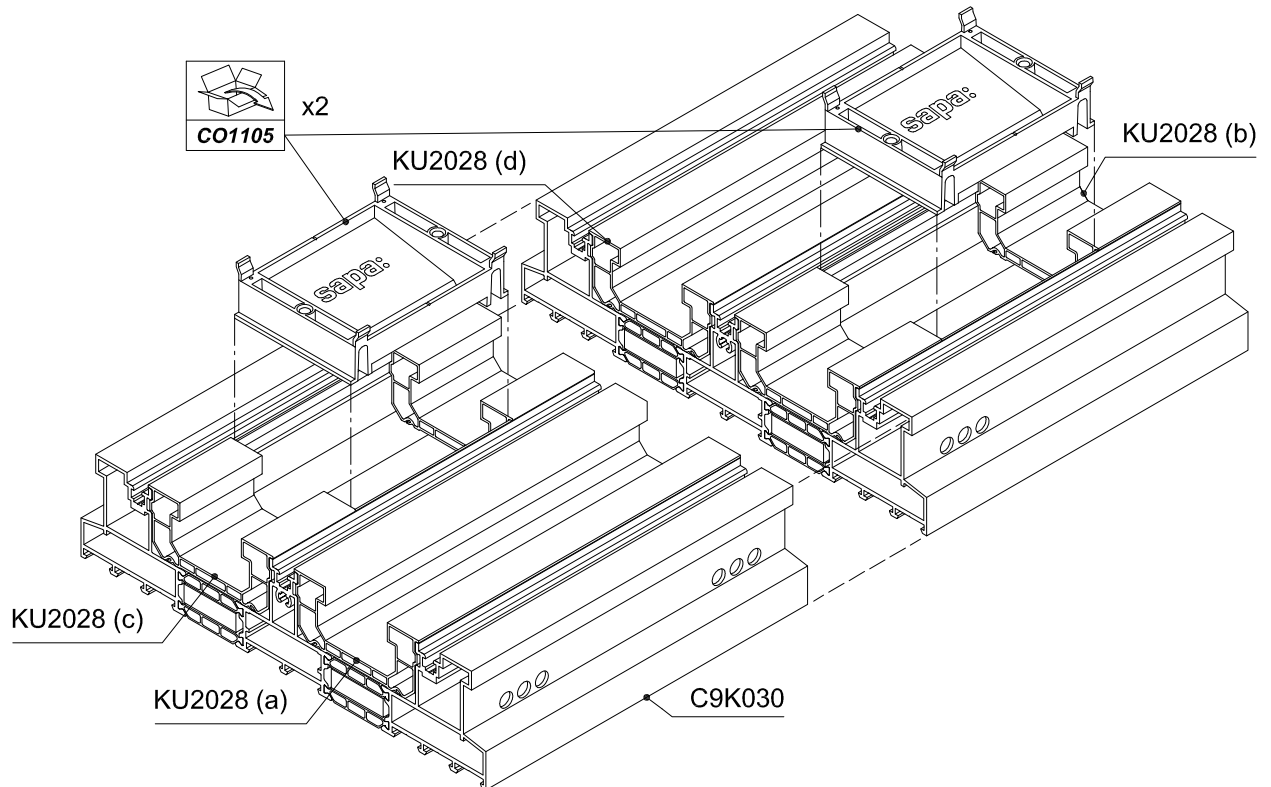
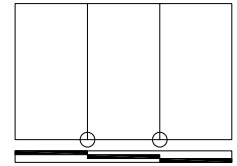

**ASSEMBLAGGIO TAPPO CENTRALE CO1105/CO1104 PROFILATO INFERIORE C9K030**

2 / 2



J.4.2 - D  
J.4.39

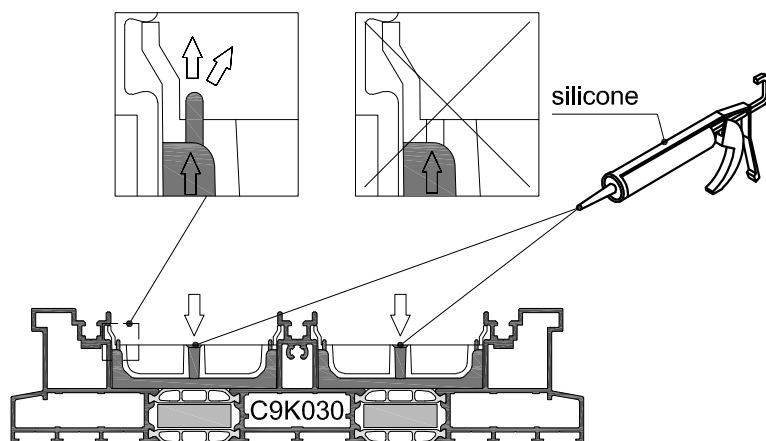
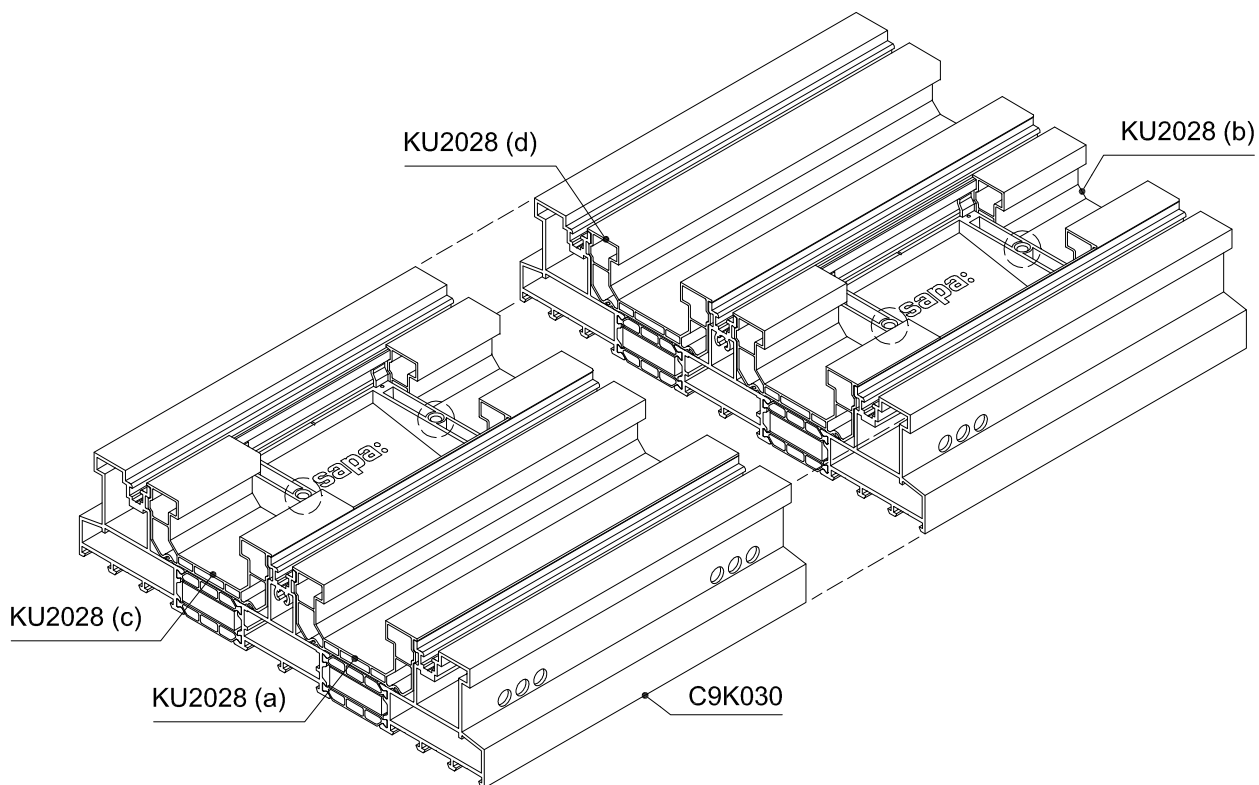
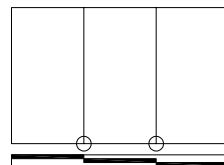

## 3-BINARI TELAIO TAGLI 45°

### SIGILLATURA PROFILATO INFERIORE C9K030 CON VS9950/VS9951/VS9964 E VS9965

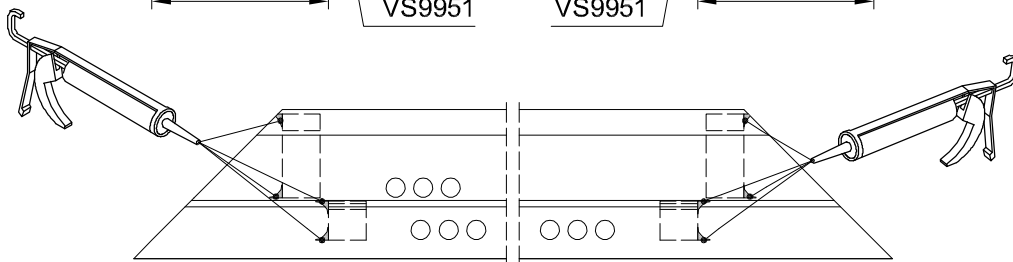
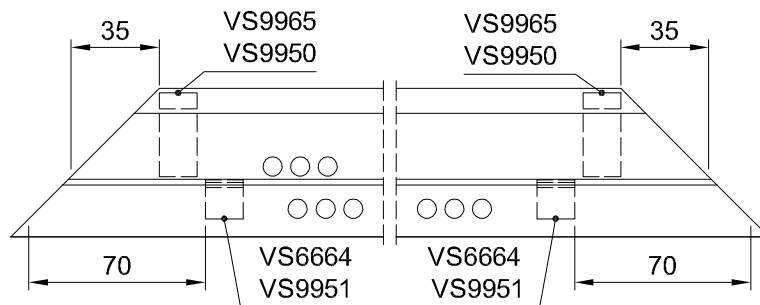
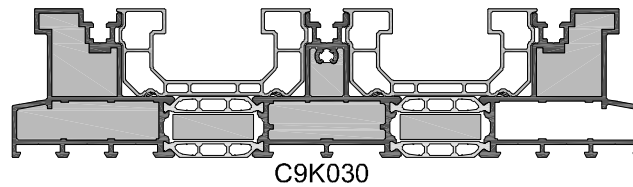
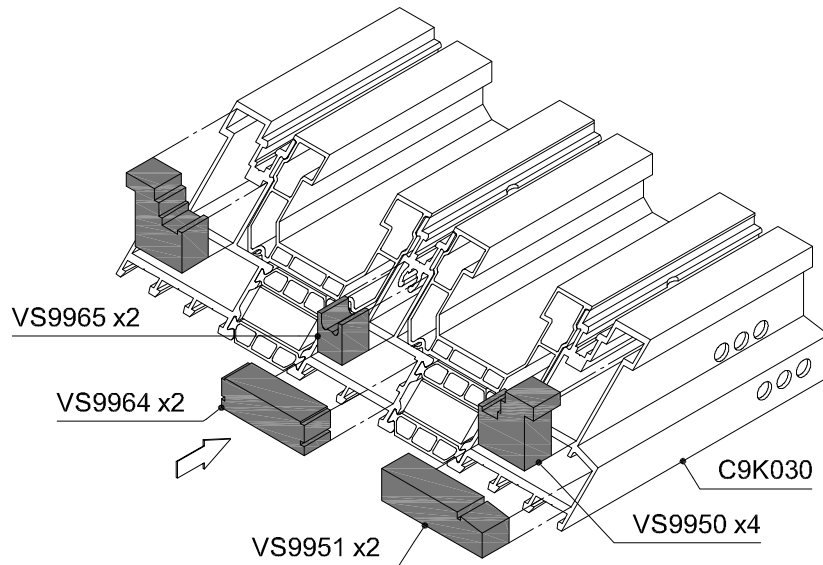
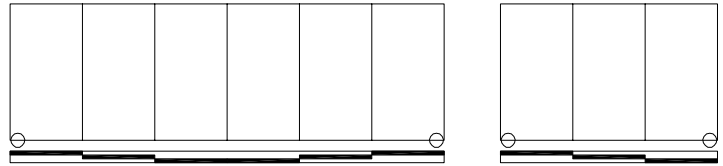

**ASSEMBLAGGIO TAPPO CENTRALE CO1111 PROFILATO SUPERIORE C9K030**

1 / 2



J.4.2 - E  
J.11.18

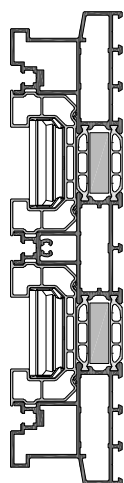
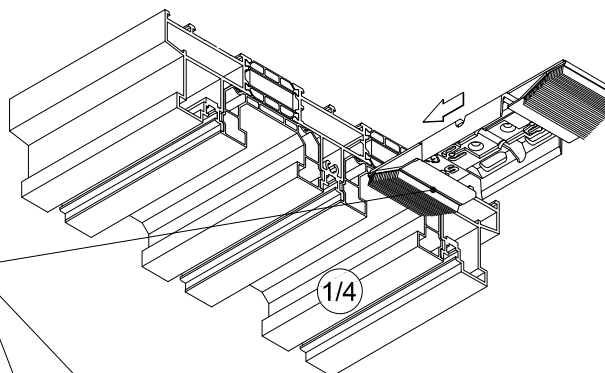
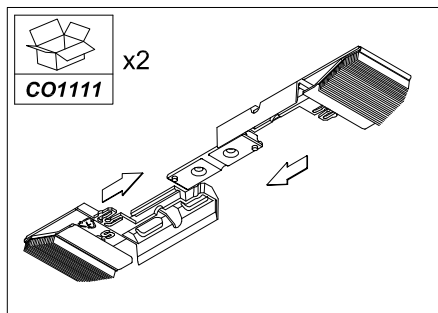
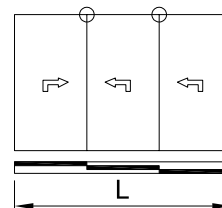

C9K030

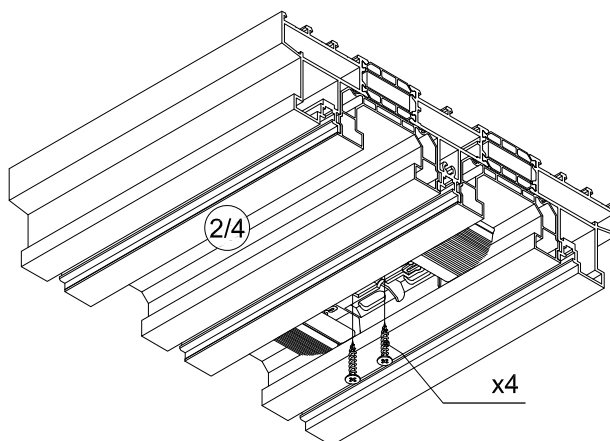
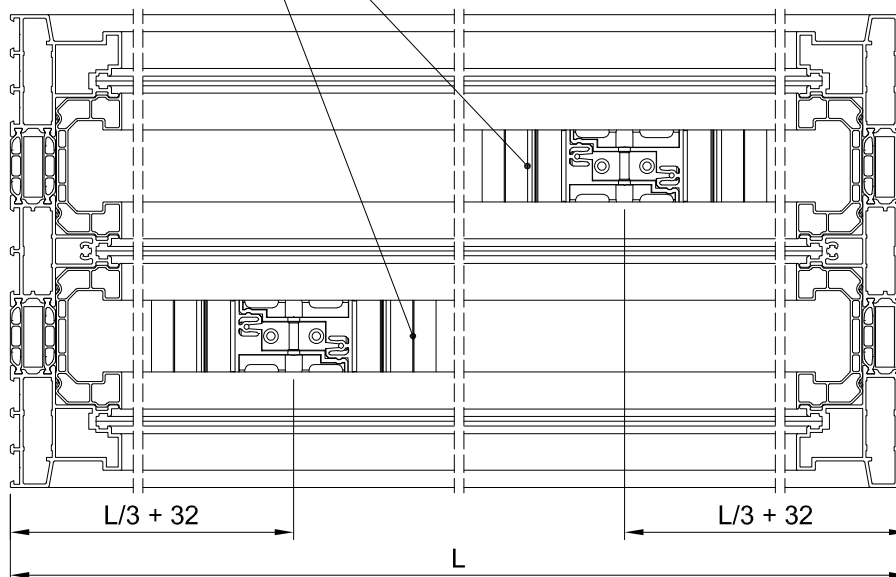

### ASSEMBLAGGIO TAPPO CENTRALE CO1111 PROFILATO SUPERIORE C9K030

2 / 2



J.4.2 - E  
J.11.18

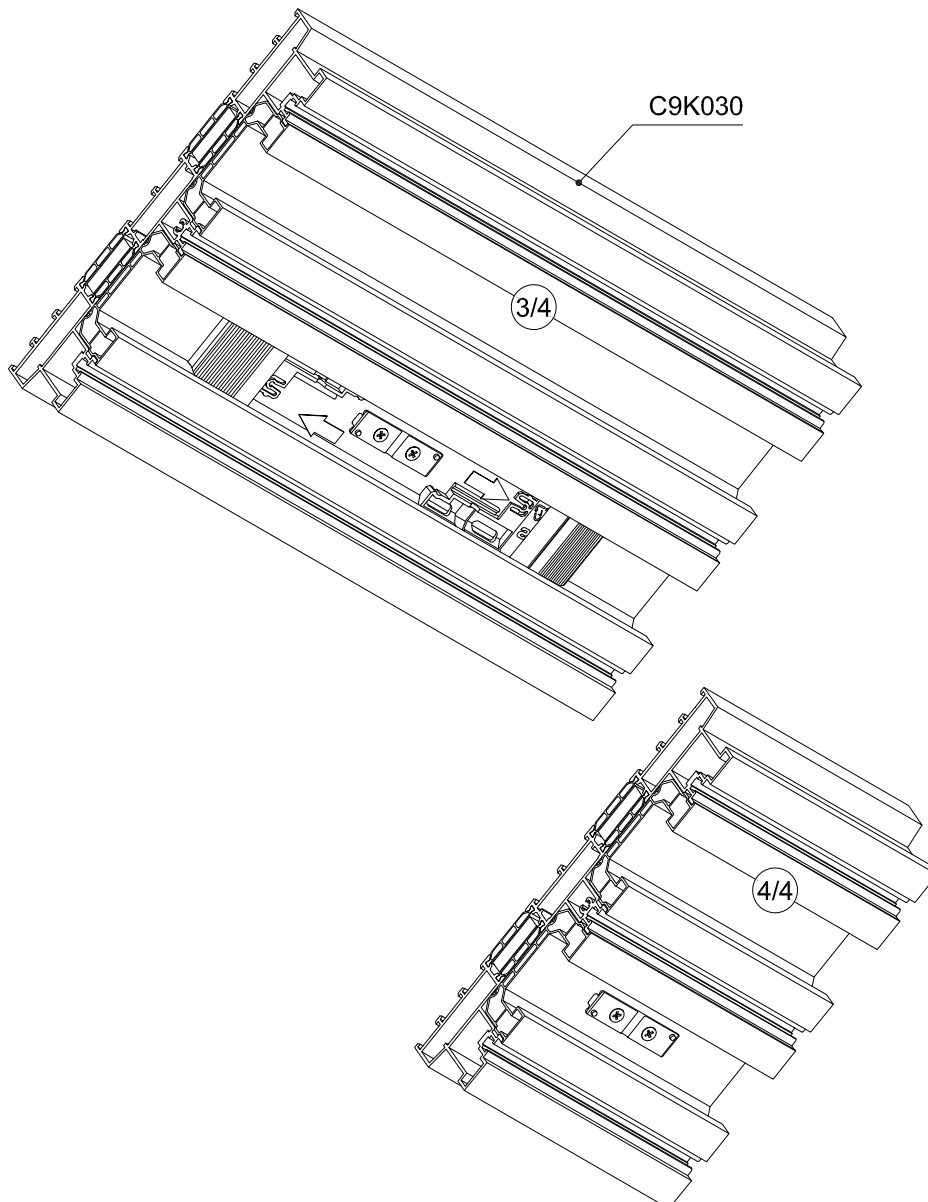
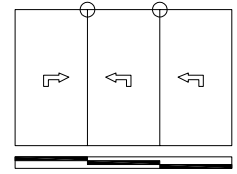

**ASSEMBLAGGIO PUNTI DI CHIUSURA - ALZANTE-SCORREVOLE (ZB0034/ZB0035/ZB0036)**

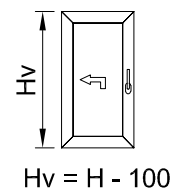
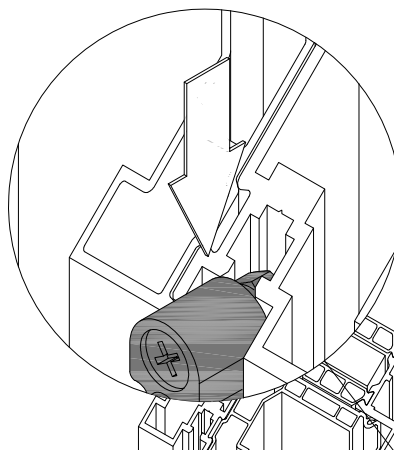
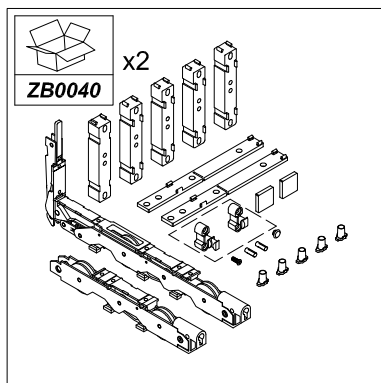
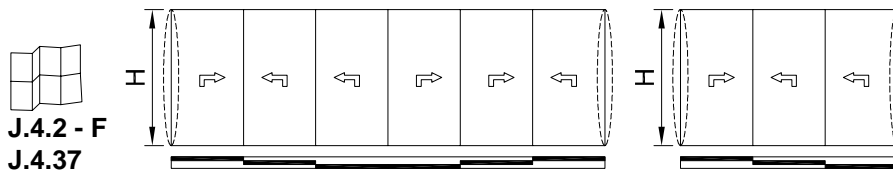

Hv = 1878 - 2777

SCG641 x8  
ZB0040  
80H520 x8

ZB0040

Hv = 2010 - 2909

CO2211 x8  
ZB0040  
80H520 x16

SF3925 x4

ZB0040

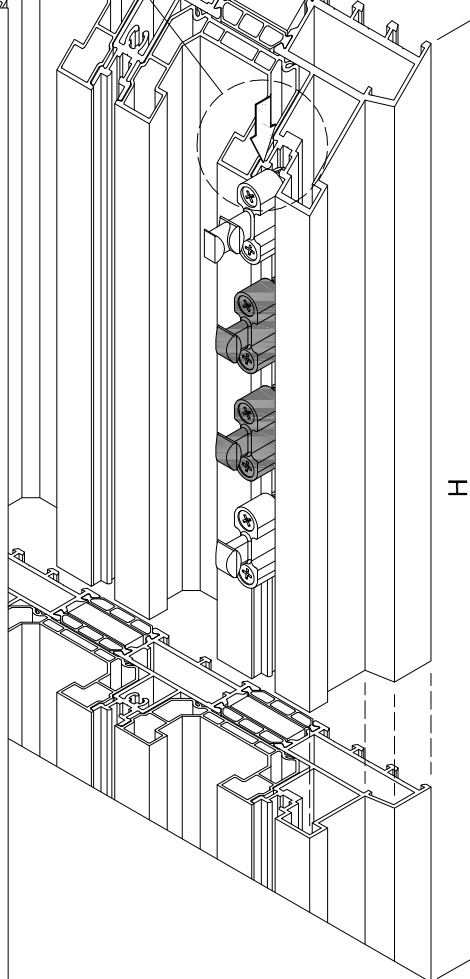

## 3-BINARI TELAIO TAGLI 45°

### ASSEMBLAGGIO PROFILATI TELAI CON SQUADRETTE

1 / 3



J.4.2 - A  
J.4.5

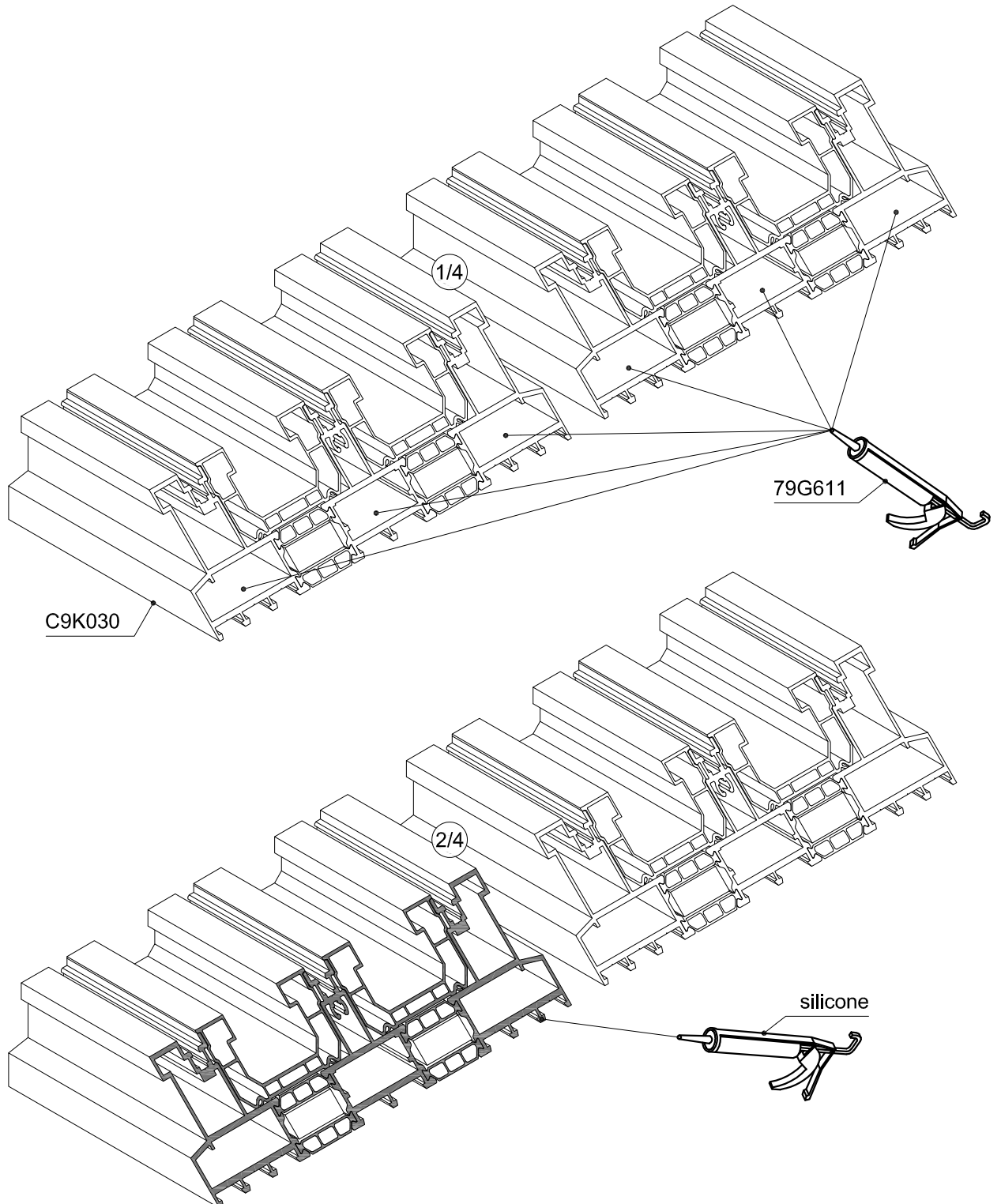
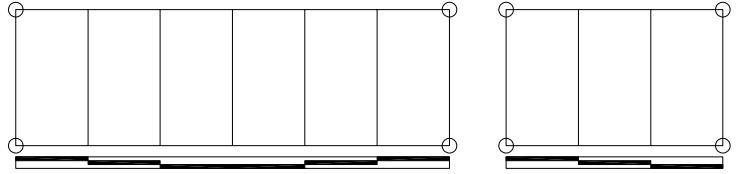

**ASSEMBLAGGIO PROFILATI TELAI CON SQUADRETTE**

2 / 3



J.4.2 - A  
J.4.5

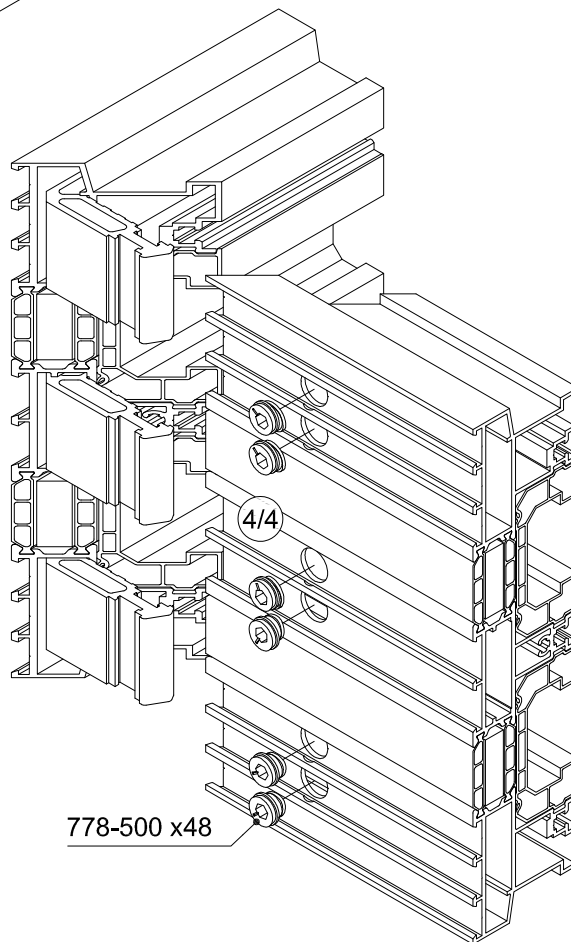
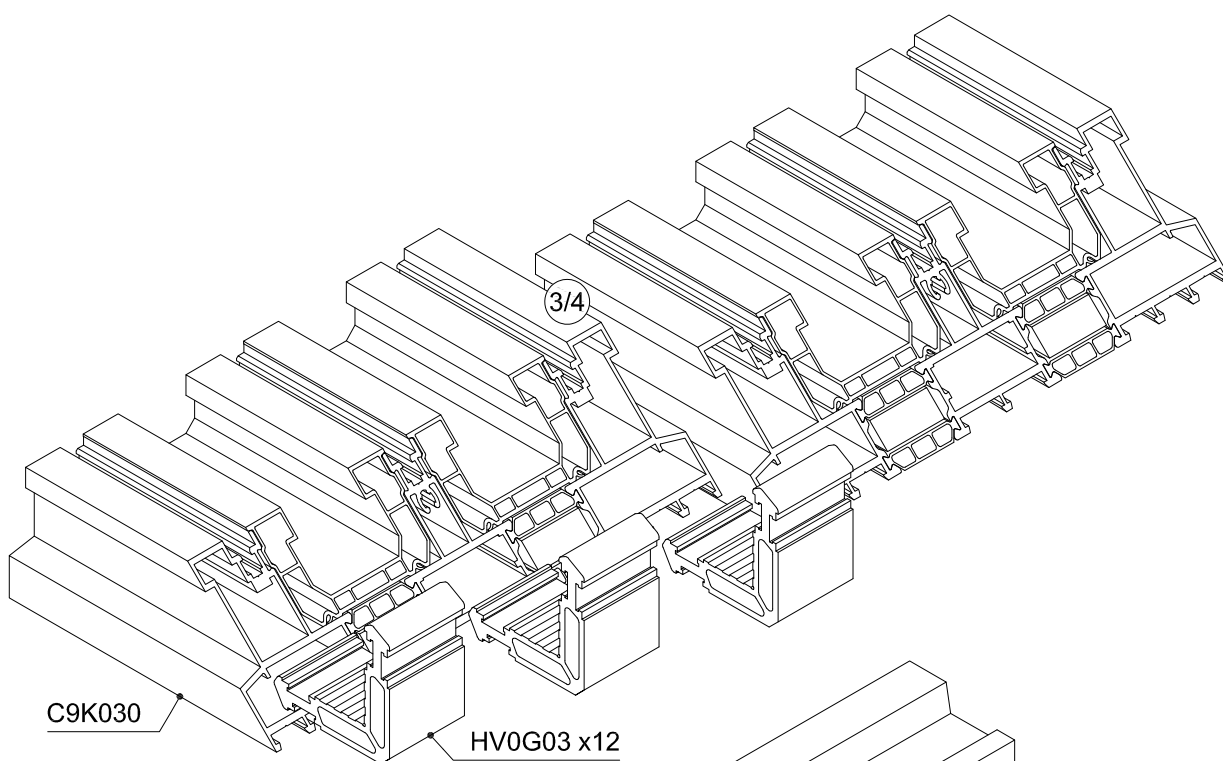
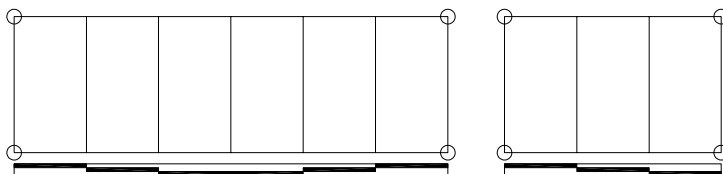





**ASSEMBLAGGIO CAPPETTA DI DRENAGGIO C9A003**



J.4.2 - B  
J.4.7

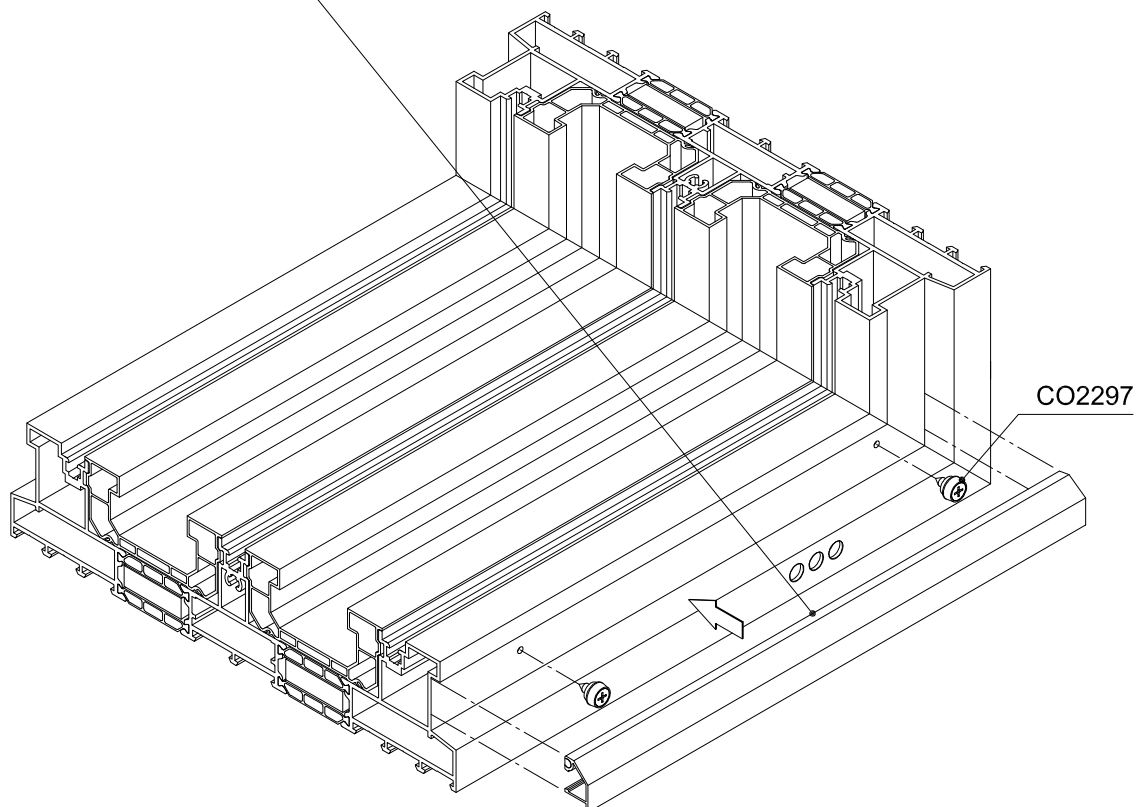
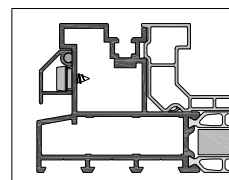
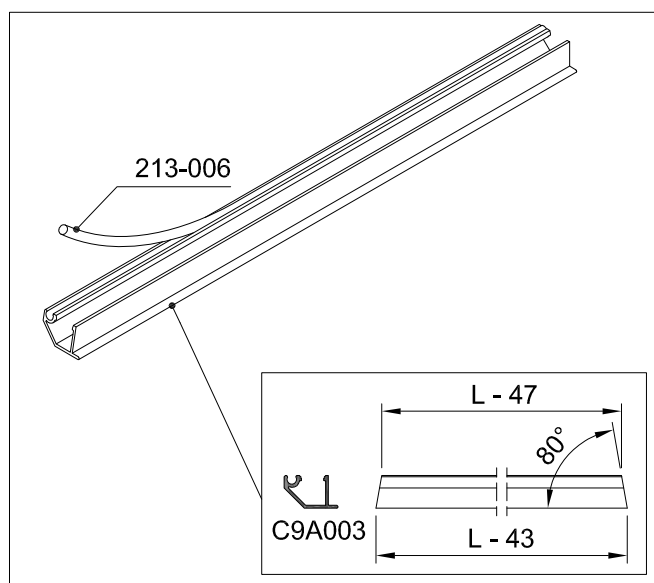
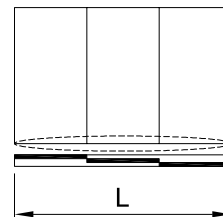
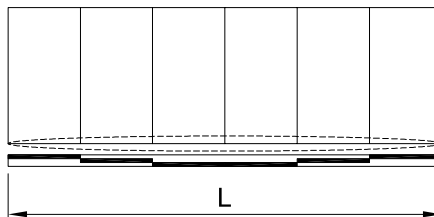

## 3-BINARI TELAIO TAGLI 45°

### OPERAZIONI C9A004 + VS2404

1 / 3



J.4.2 - G

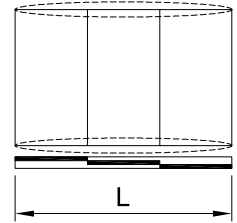
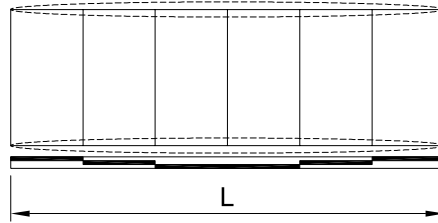

A-A

1/3

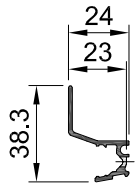

C9A004

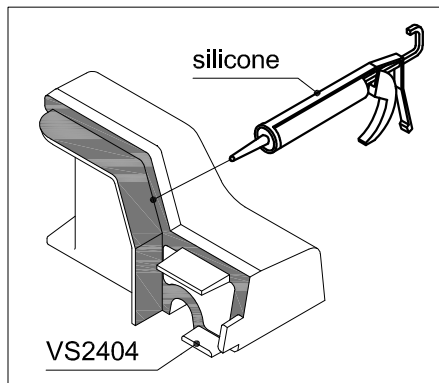
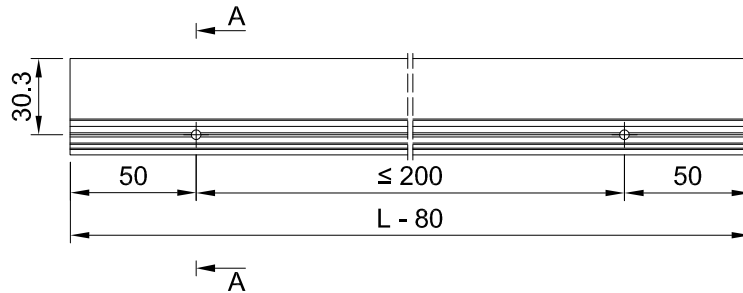

silicone

VS2404

2/3

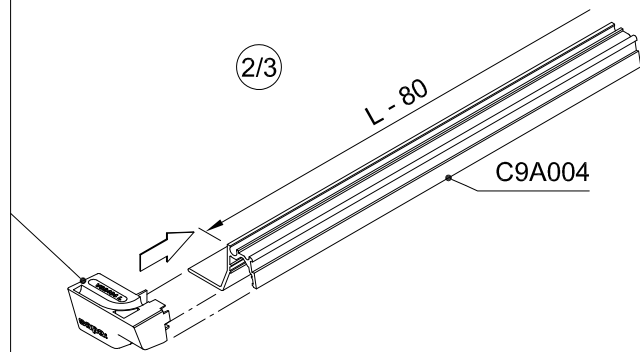

C9A004

3/3

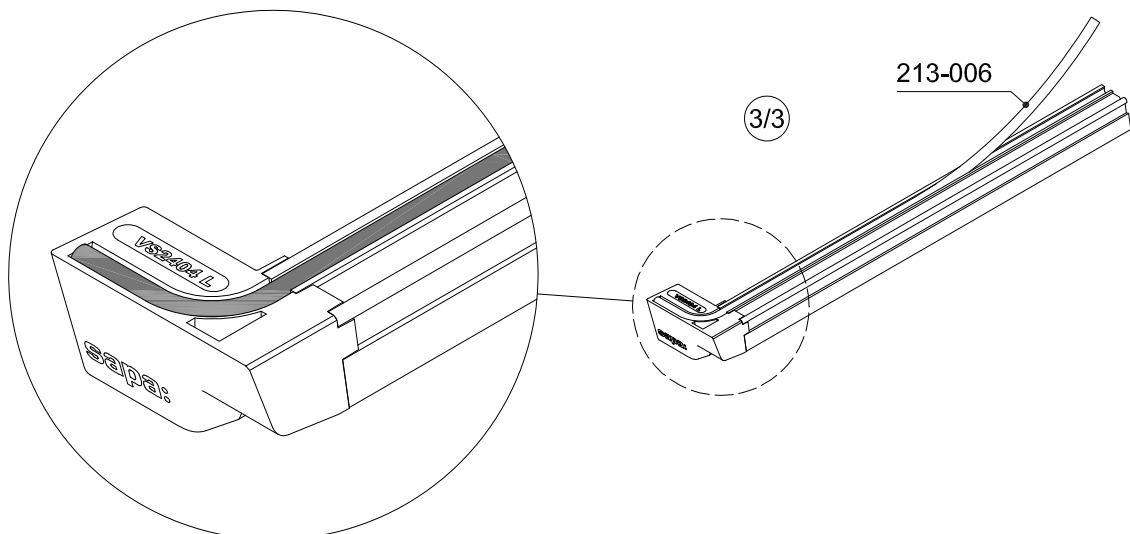

213-006

**ASSEMBLAGGIO C9A004 + VS2404**

2 / 3



J.4.2 - G

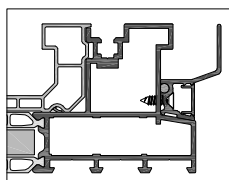
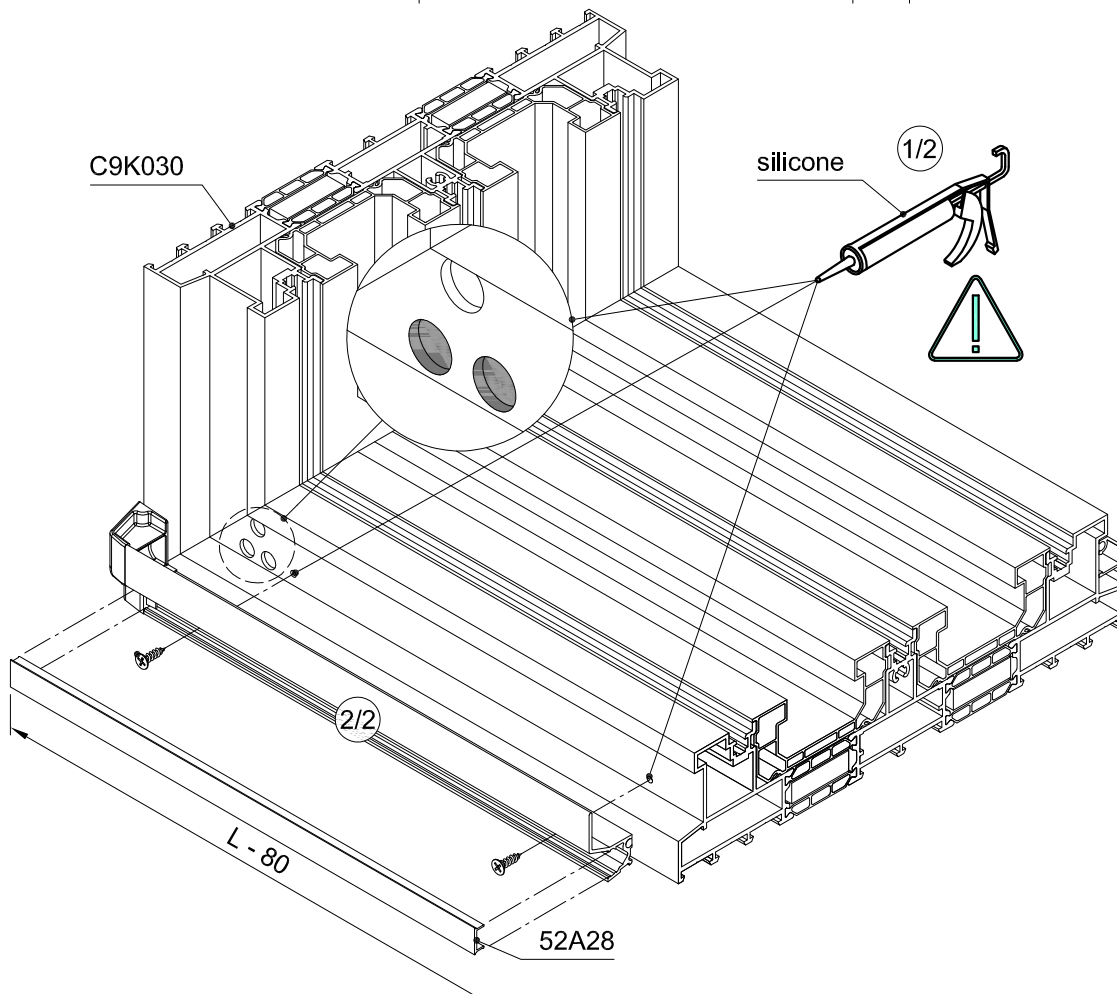
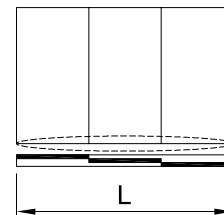
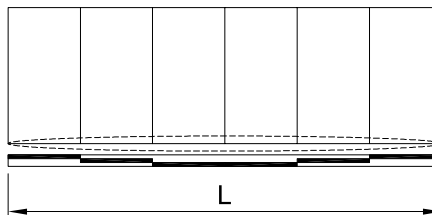

### ASSEMBLAGGIO C9A004 + VS2404 - OPTIONAL

3 / 3

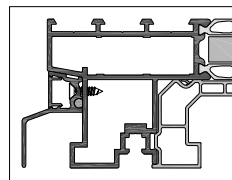
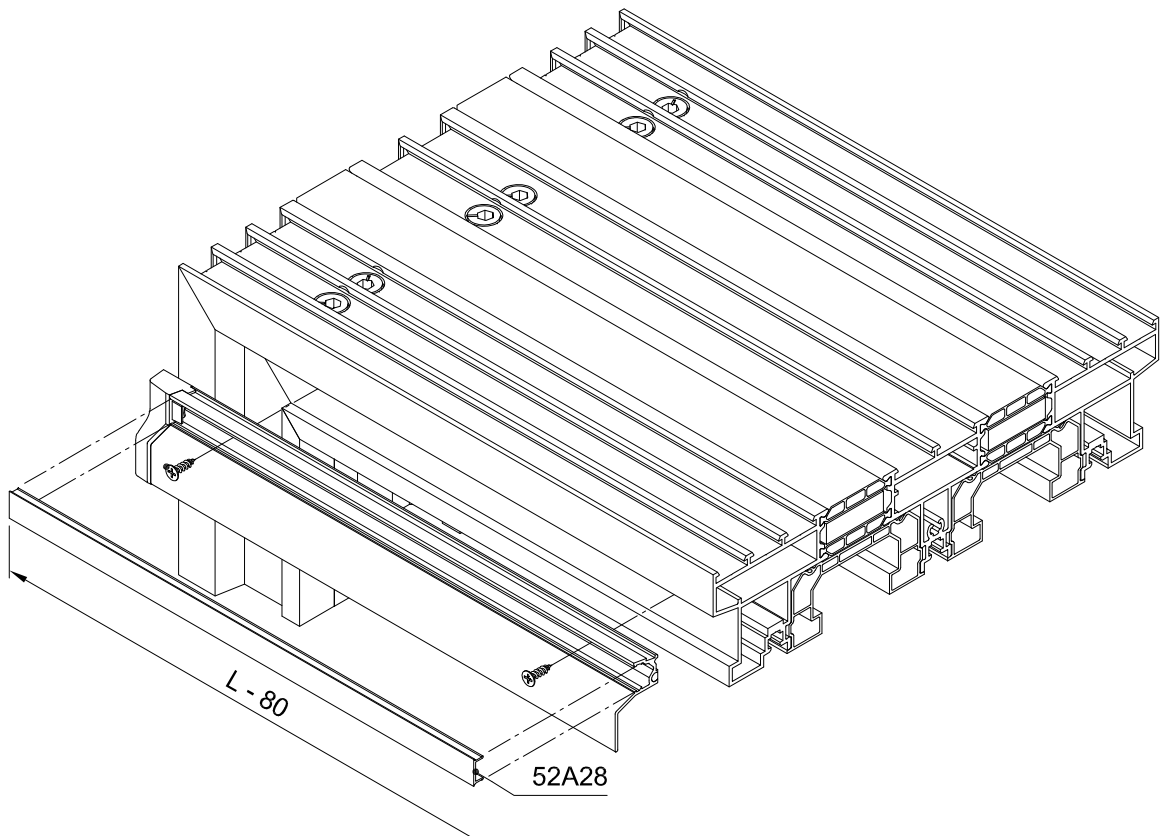
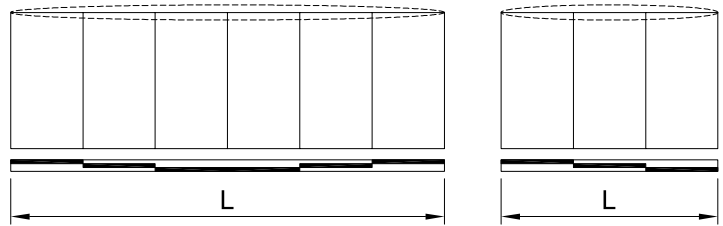

**ASSEMBLAGGIO CO1103**

1 / 3

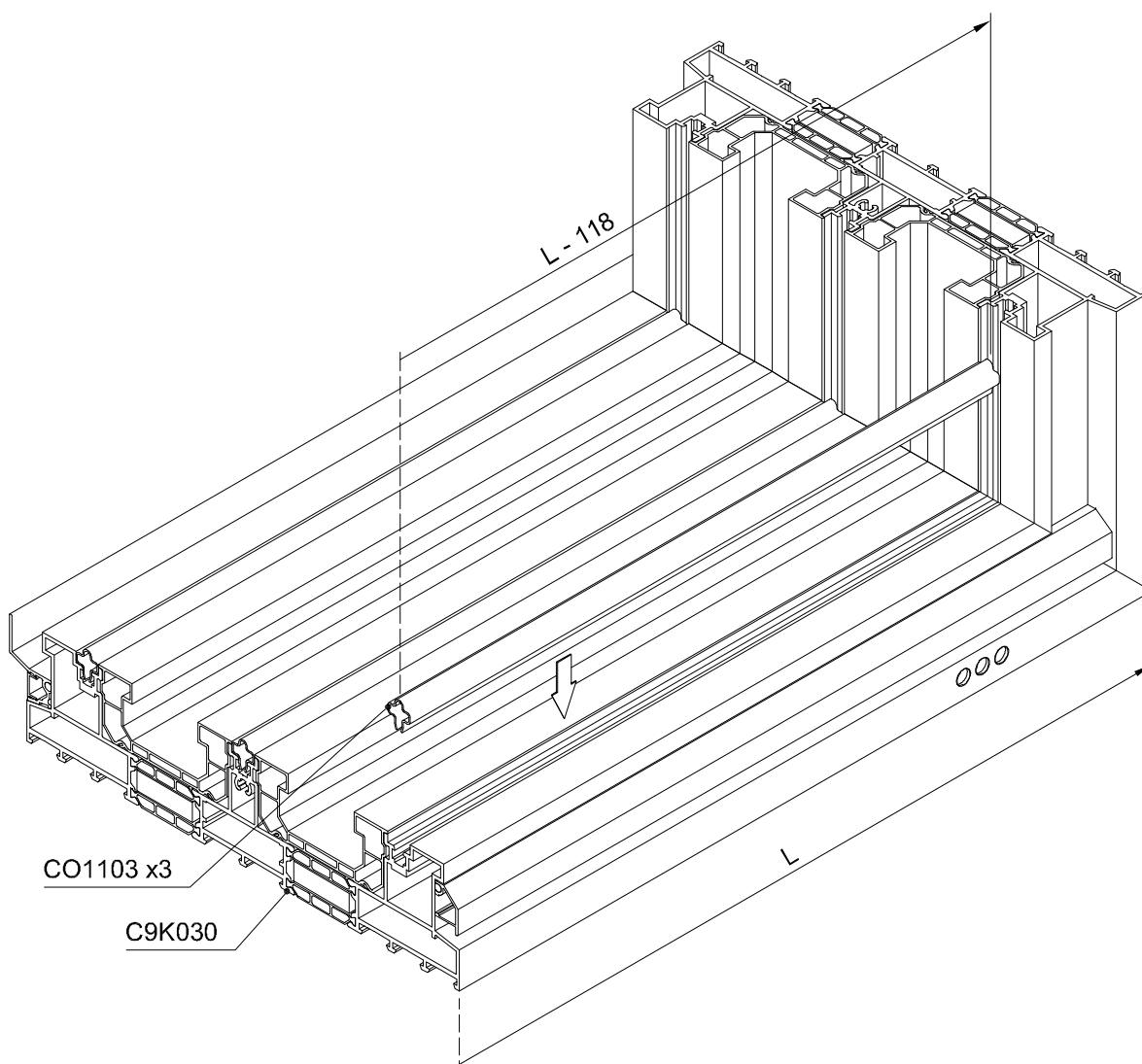
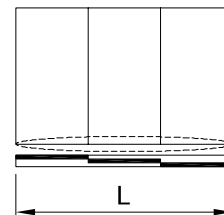

ASSEMBLAGGIO CO1103 PER FISSO-SCORREVOLE-FISSO

2 / 3

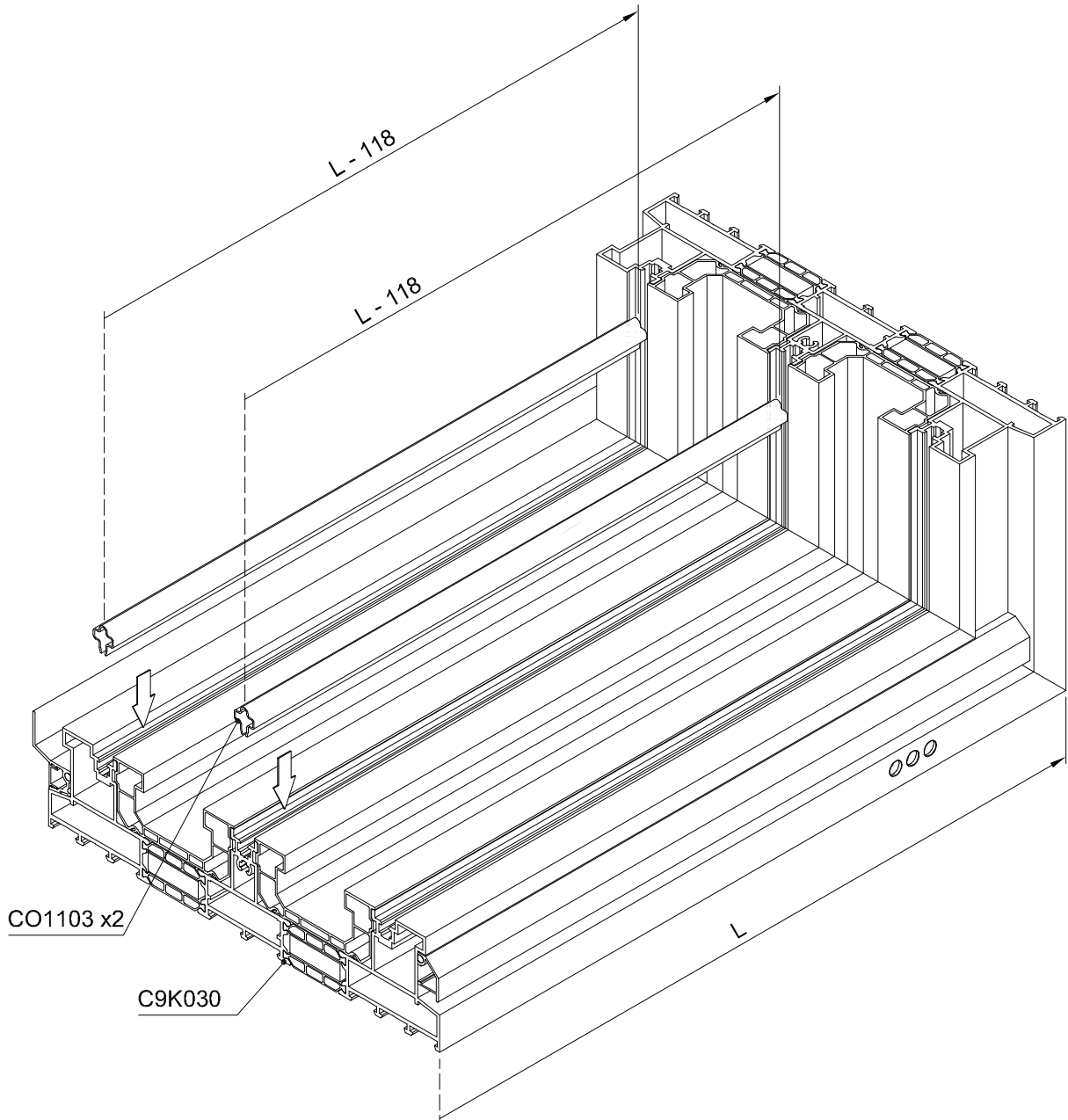
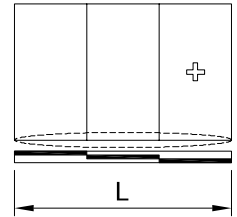

**ASSEMBLAGGIO CO1103 E ZB0038 PER SCHEMA 4 ANTE**

3 / 3

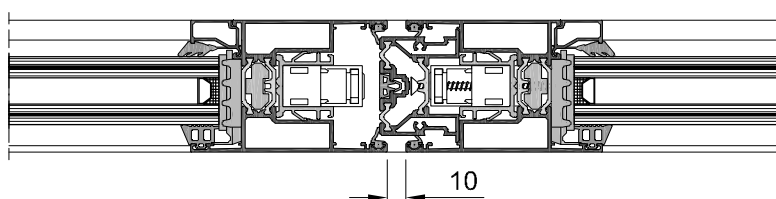
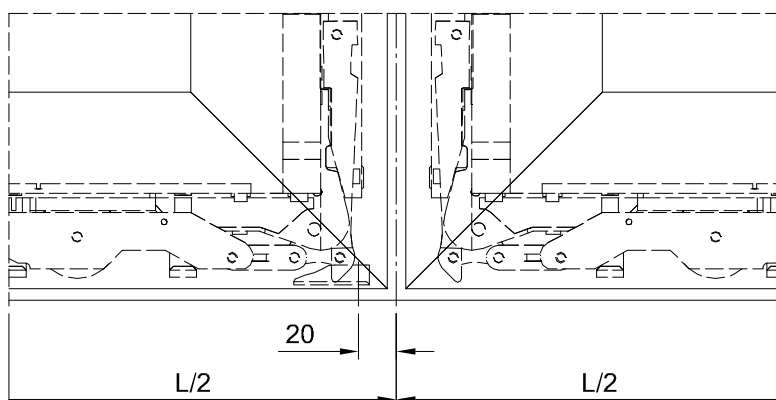
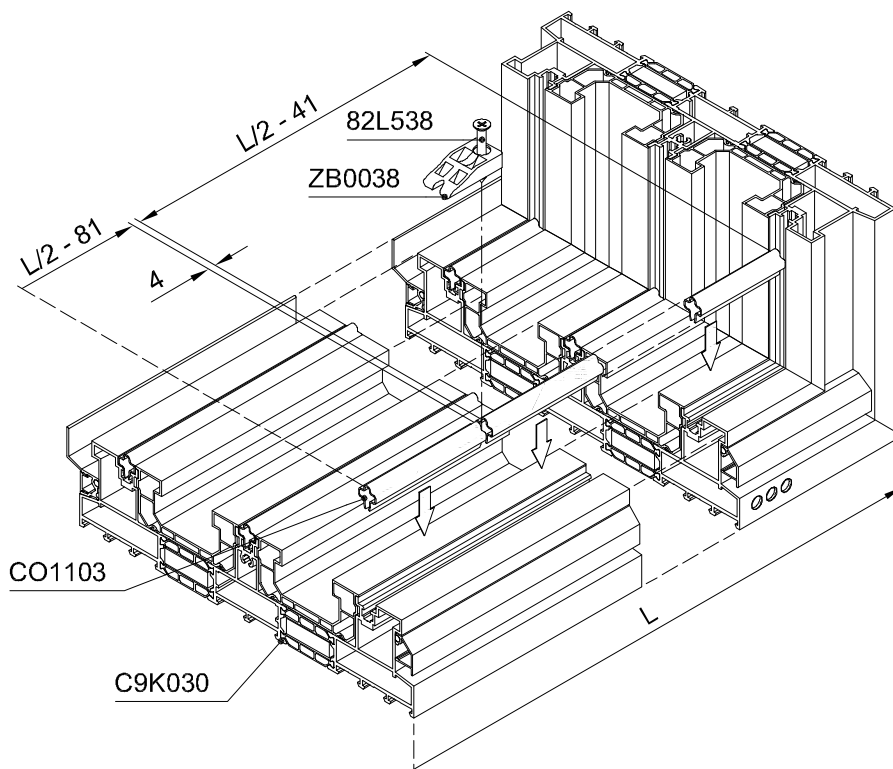
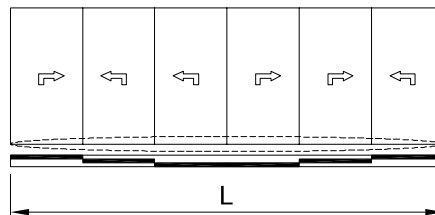



## 3-BINARI TELAIO TAGLI 45°

### INSTALLAZIONE PUNTI DI CHIUSURA

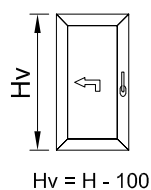
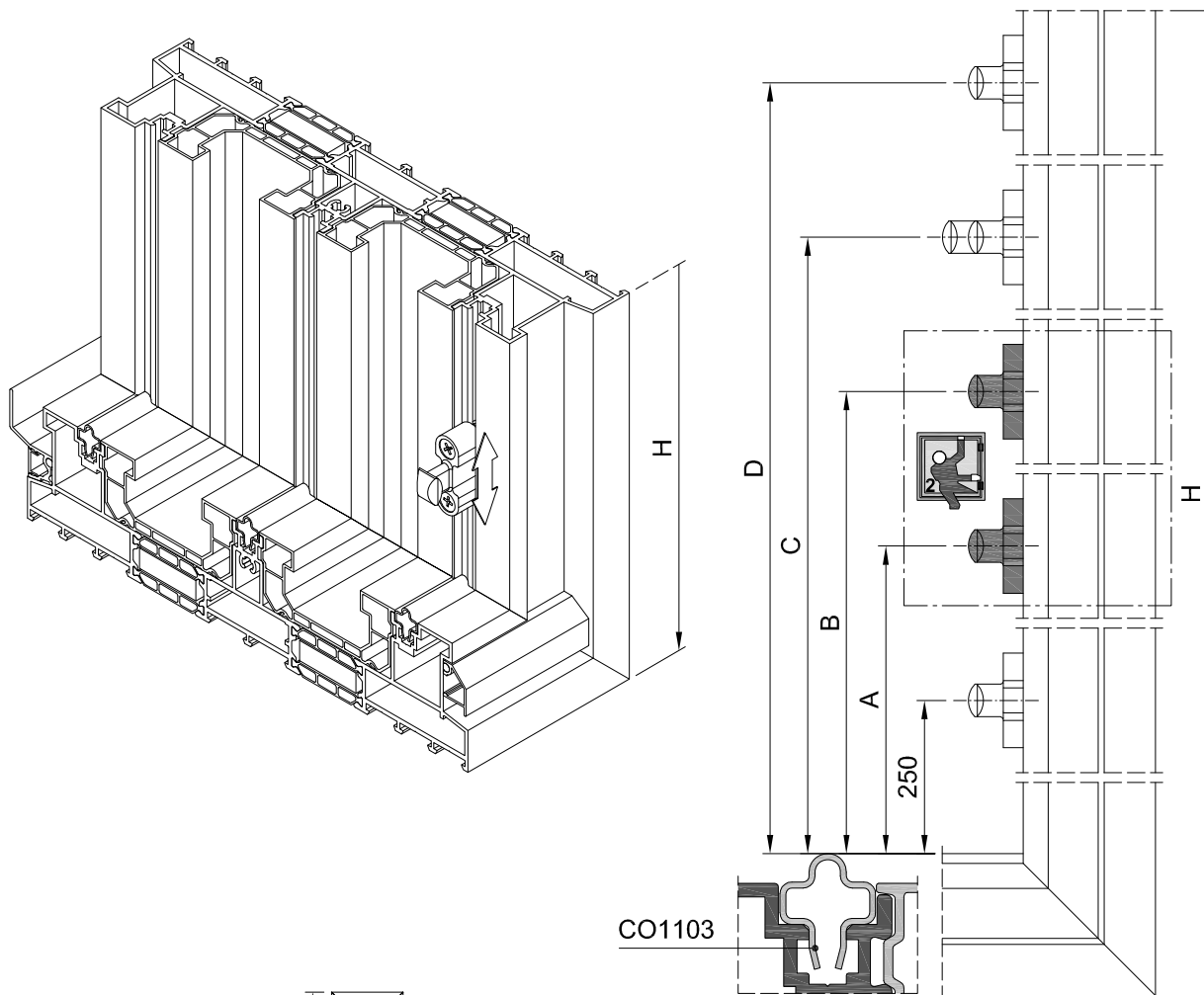
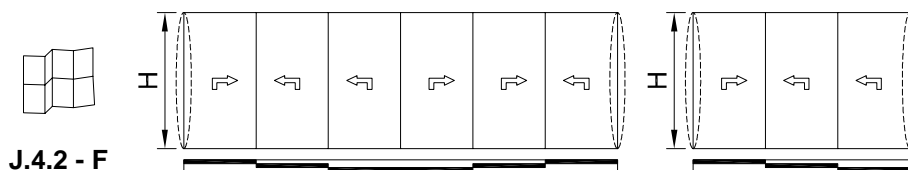

	Hv	Hv				
			A	B	C	D
	2010 - 2309	ZB0034	750	1200	1600	Hv - 271
	2310 - 2609	ZB0035			1900	
	2610 - 2909	ZB0036			2200	
	2910 - 3209	ZB0035 + ZB0046			1900	
	3210 - 3509	ZB0036 + ZB0046			2200	
	1312 - 2009	ZB0033		600	1000	

**ASSEMBLAGGIO GUARNIZIONE DI FINITURA RU9704**

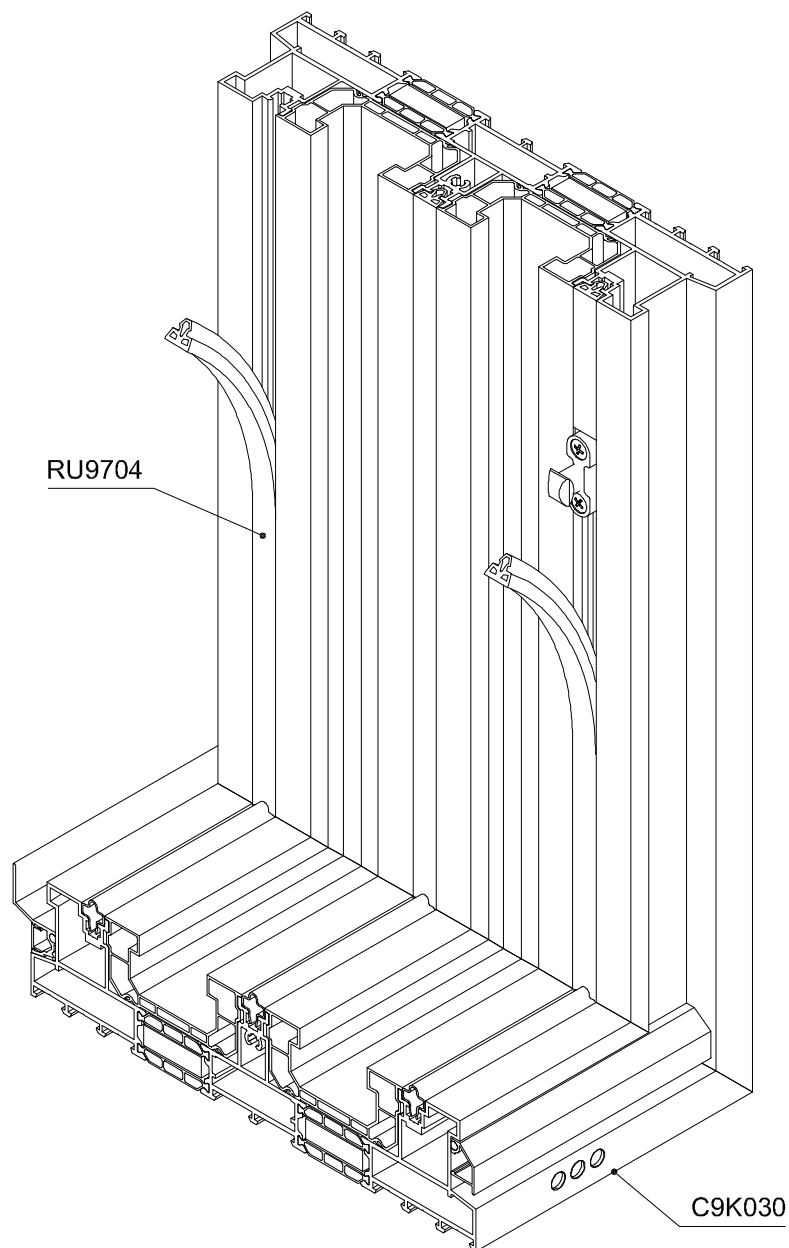
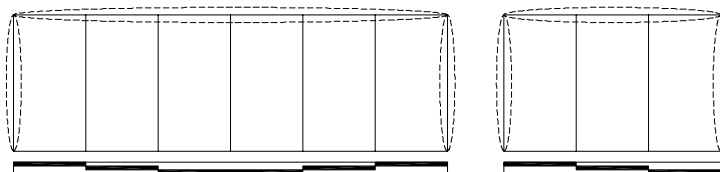

ASSEMBLAGGIO TAPPO CENTRALE CO1105/CO1104 PROFILATO INFERIORE C9K030

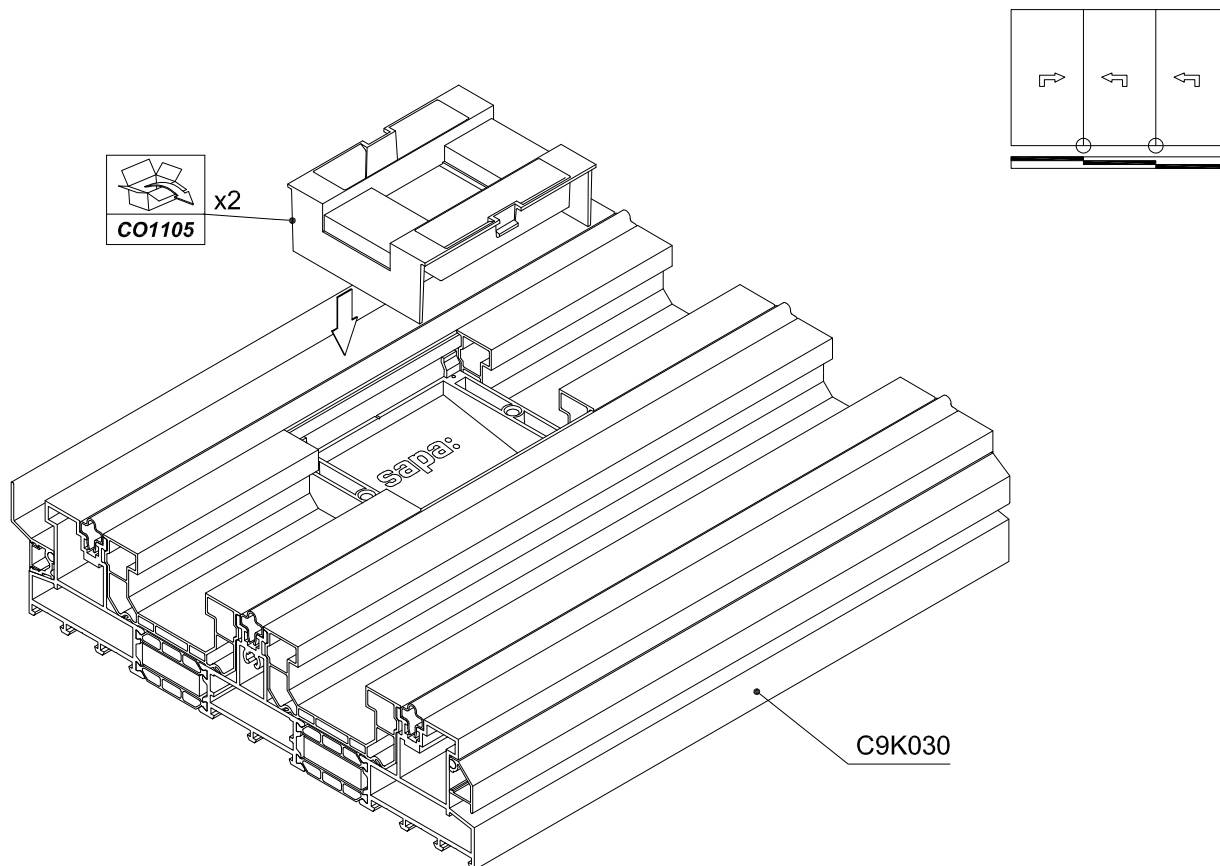



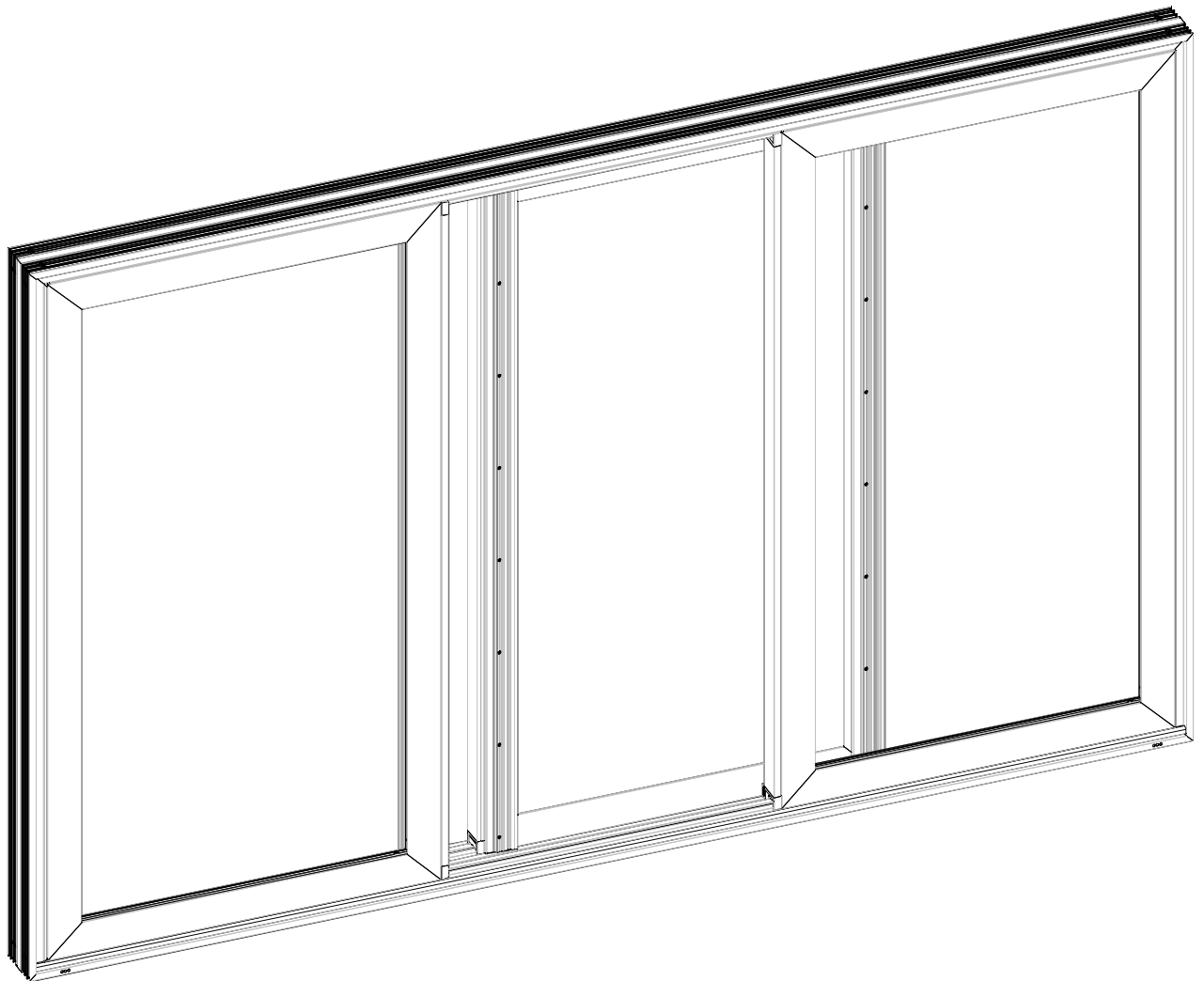

**PANORAMICA ASSEMBLAGGIO**

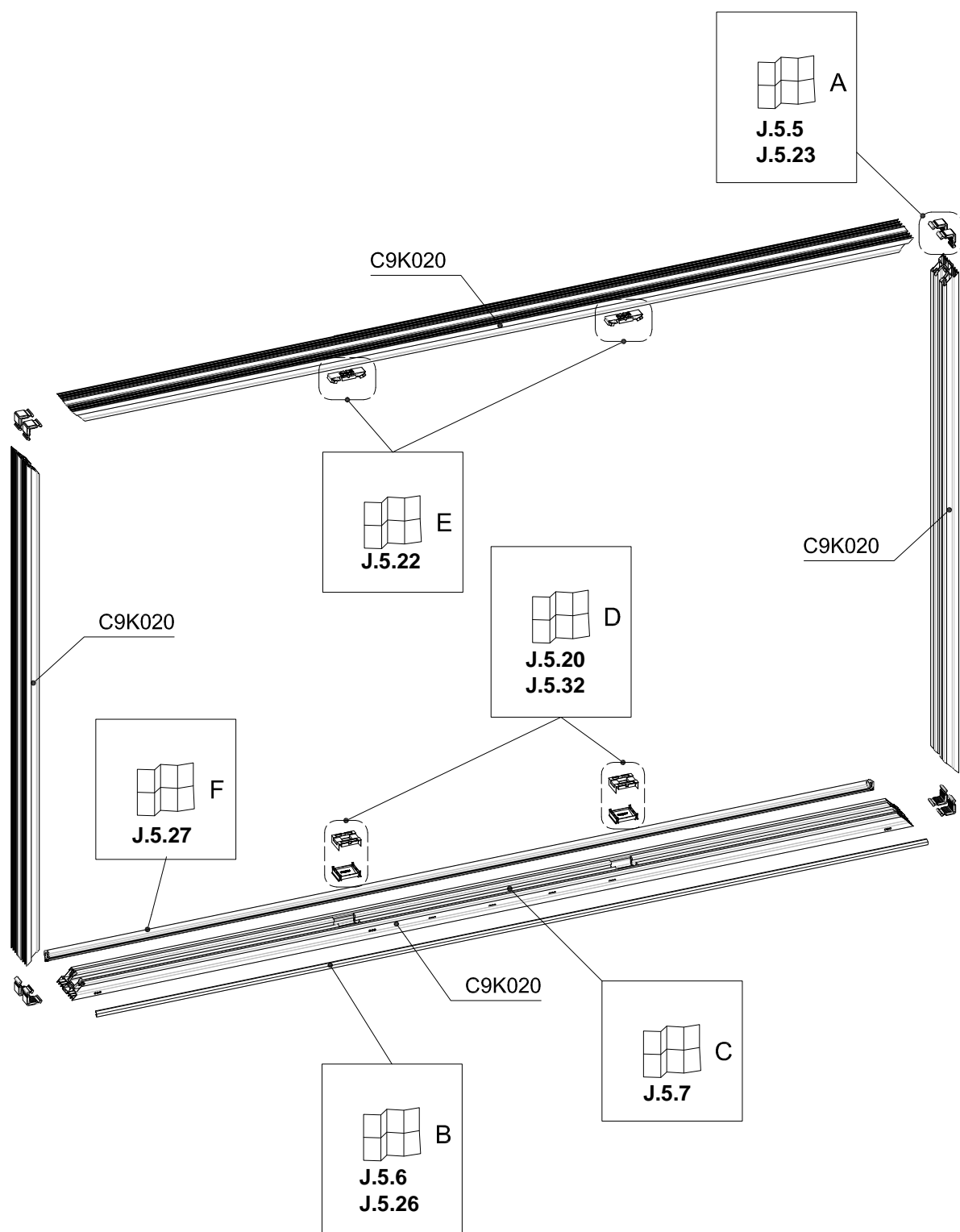

## 2-BINARI FISSO-ALZANTE-SCORREVOLE-FISSO TAGLI 45°

### CONTENUTO

2-binari fisso-alzante-scorrevoles-fisso tagli 45° .....	J.6.1
Panoramica assemblaggio .....	J.6.2
Contenuto .....	J.6.3



Operazioni C9K020 + KU2028 e assemblaggio BT6006 .....	J.6.4
Lavorazione squadrette per C9K020 .....	J.6.5



Operazioni cappetta di drenaggio .....	J.6.6
C9K020 + KU2028 panoramica drenaggi .....	J.6.7
C9K020 lavorazione drenaggio - J (optional 1/2) .....	J.6.8
C9K020 lavorazione drenaggio - J (optional 2/2) .....	J.6.9
C9K020 lavorazione drenaggio - H .....	J.6.10
C9K020 lavorazione drenaggio - B .....	J.6.11
C9K020 lavorazione drenaggio - A .....	J.6.12
C9K020 lavorazione drenaggio - G .....	J.6.13
C9K020 lavorazione drenaggio - M .....	J.6.14
KU2028 lavorazione drenaggio - K1 .....	J.6.15
KU2028 lavorazione drenaggio - K2 .....	J.6.16
KU2028 lavorazione drenaggio - K3 .....	J.6.17



Assemblaggio VS0107 e KU2028 su C9K020 profilato inferiore .....	J.6.18
Assemblaggio tappo centrale CO1105 profilato inferiore .....	J.6.19
Sigillatura profilato inferiore C9K020 con VS9950 e VS9951 .....	J.6.21
Assemblaggio tappo centrale CO1111 profilato superiore C9K020 .....	J.6.22

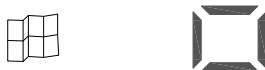

Assemblaggio profilati telai con squadrette .....	J.6.23
Assemblaggio cappetta di drenaggio C9A003 .....	J.6.26
Preparazione C9A004 + VS2404 .....	J.6.27
Assemblaggio C9A004 + VS2404 .....	J.6.28
Assemblaggio C9A004 + VS2404 - optional .....	J.6.29
Assemblaggio CO1103 e ZB0038 .....	J.6.30
Assemblaggio guarnizione di finitura RU9704 .....	J.6.31
Assemblaggio tappo centrale CO1105 profilato inferiore .....	J.6.32

**OPERAZIONI C9K020 + KU2028 E ASSEMBLAGGIO BT6006**

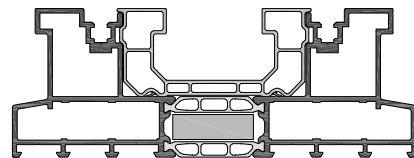
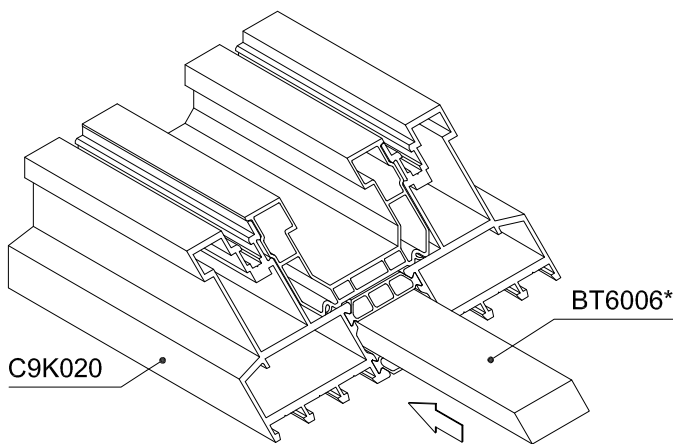
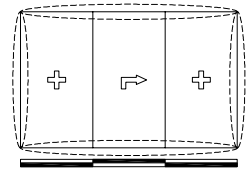
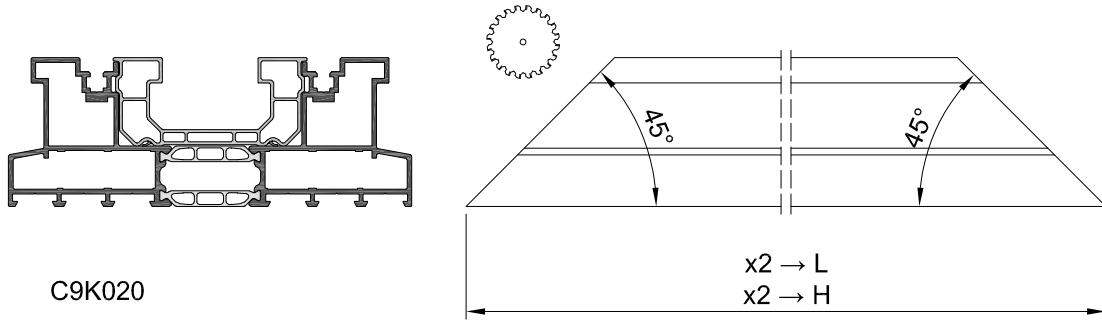
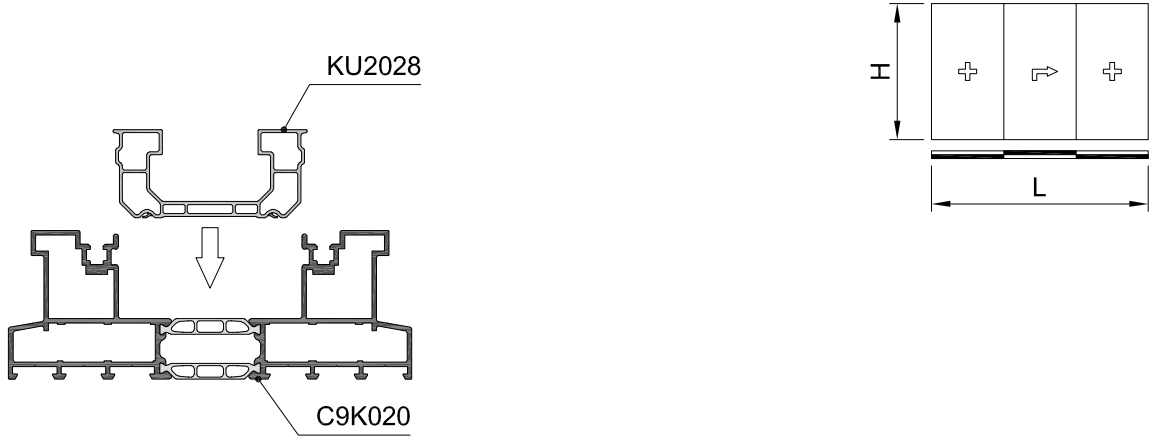

	BT6006
SHI	✓
SI	✓
I	x



## 2-BINARI FISSO-ALZANTE-SCORREVOLE-FISSO TAGLI 45°

### LAVORAZIONE SQUADRETTE PER C9K020

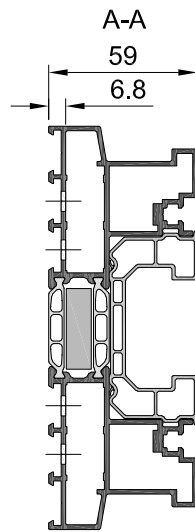
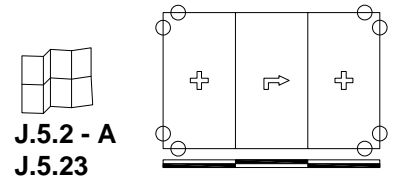
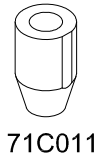

C9K020

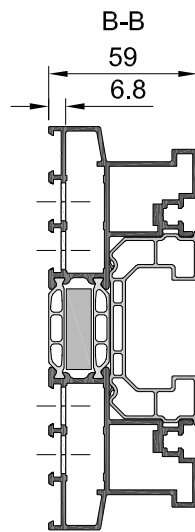
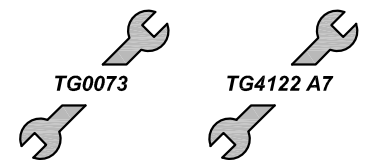
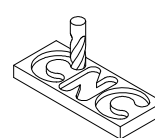
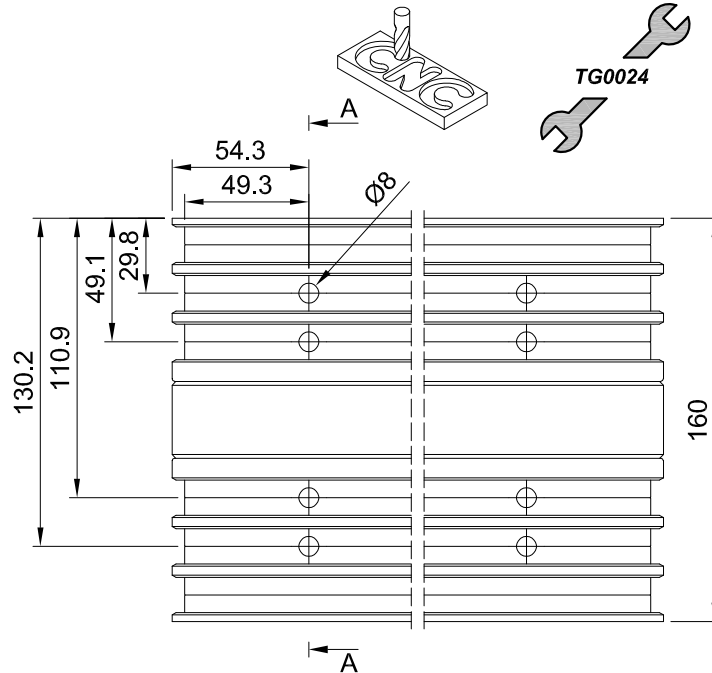

C9K020

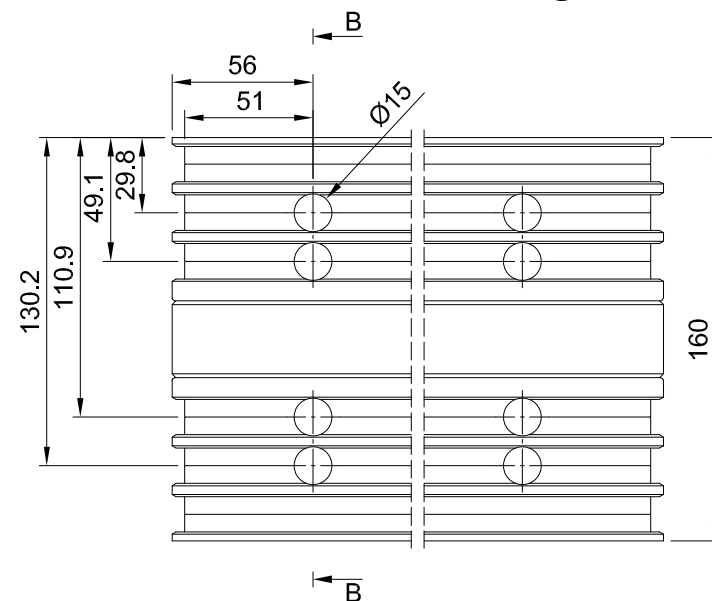

**OPERAZIONI CAPPETTA DI DRENAGGIO**

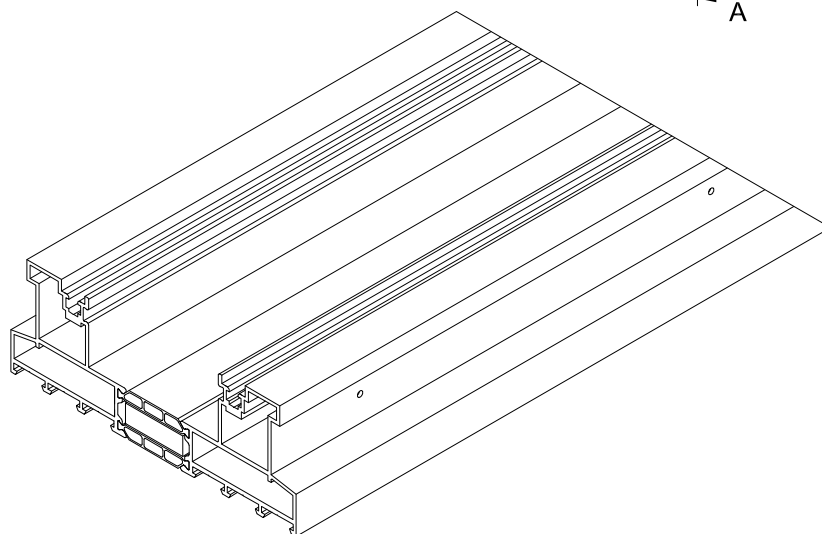
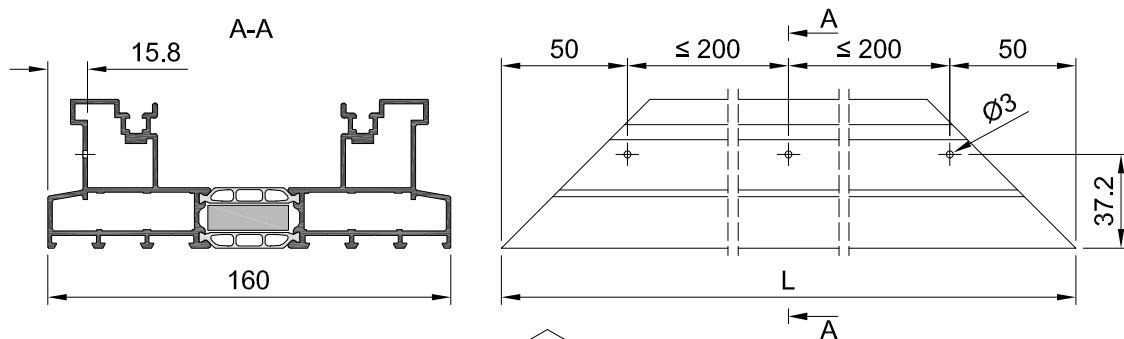
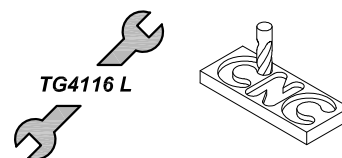
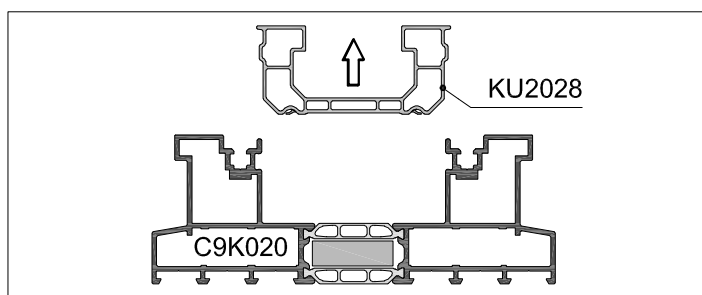
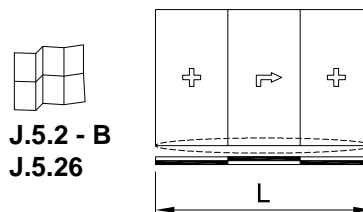

## 2-BINARI FISSO-ALZANTE-SCORREVOLE-FISSO TAGLI 45°

C9K020 + KU2028 PANORAMICA DRENAGGI

1 / 12

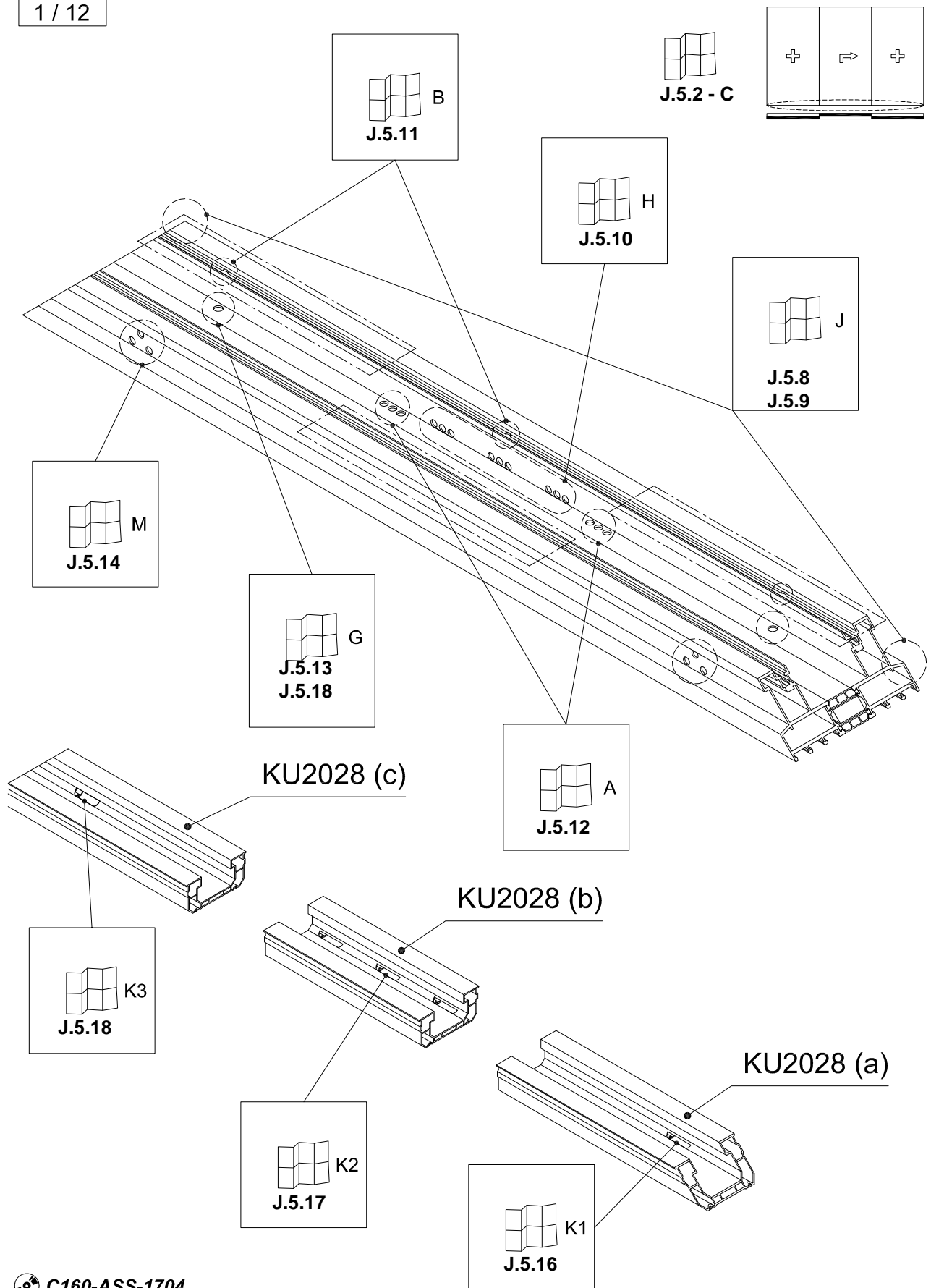

**C9K020 LAVORAZIONE DRENAGGIO - J (OPTIONAL 1/2)**

2 / 12

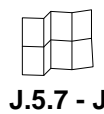

J.5.7 - J

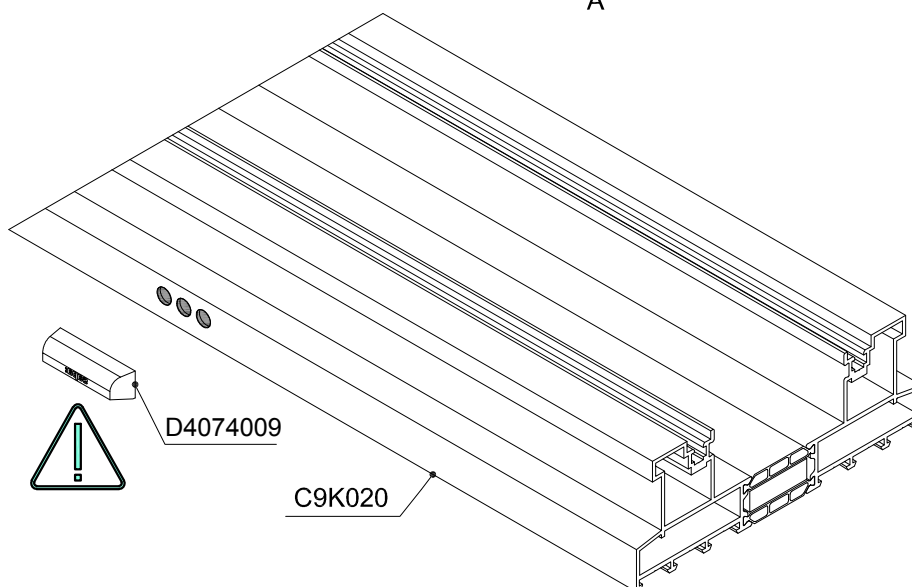
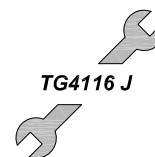
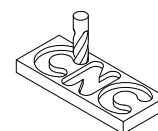
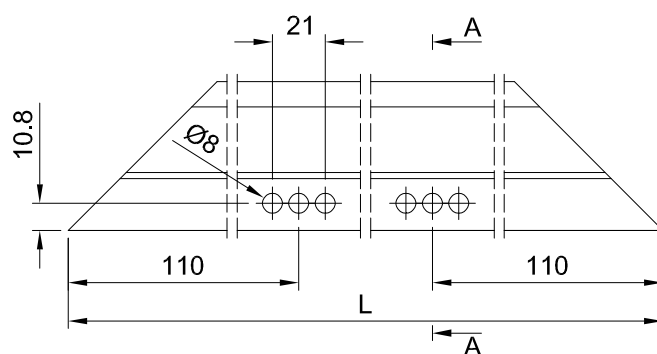
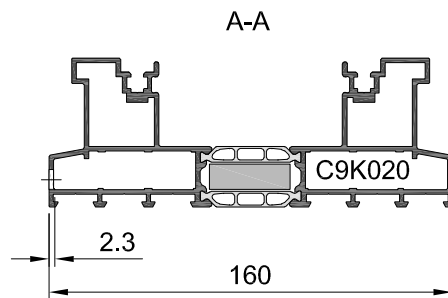
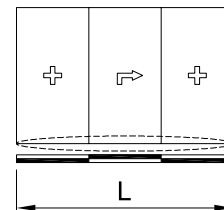

## 2-BINARI FISSO-ALZANTE-SCORREVOLE-FISSO TAGLI 45°

### C9K020 LAVORAZIONE DRENAGGIO - J (OPTIONAL 2/2)

3 / 12

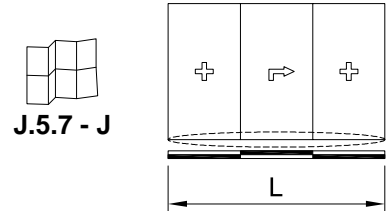

A-A

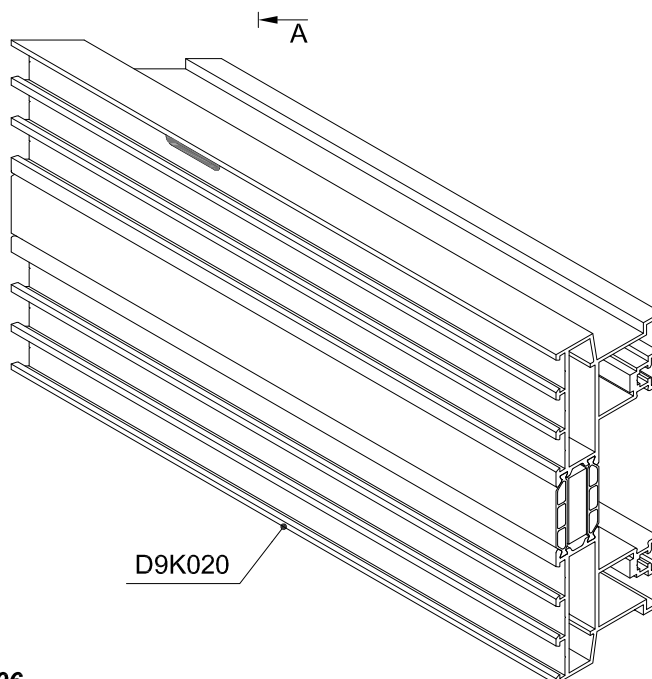
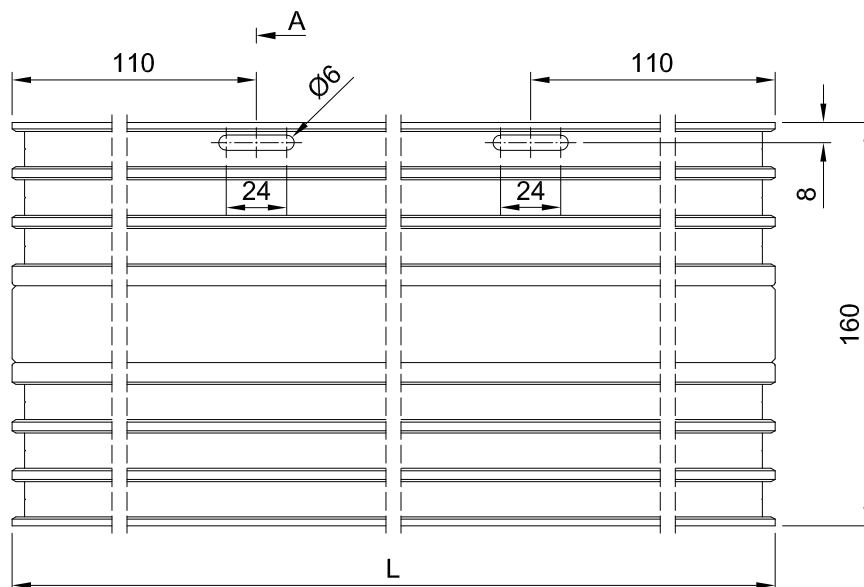
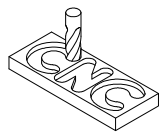
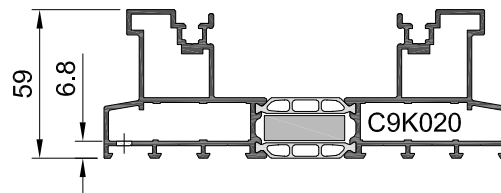

**C9K020 LAVORAZIONE DRENAGGIO - H**

4 / 12

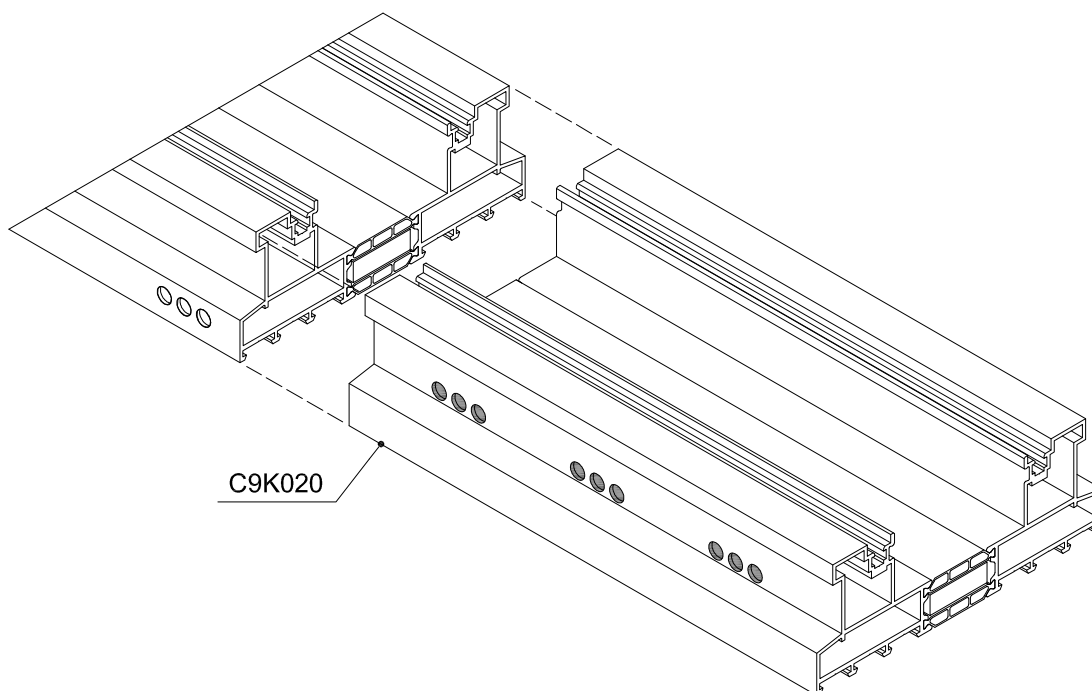
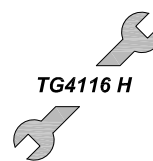
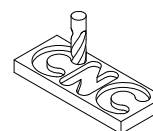
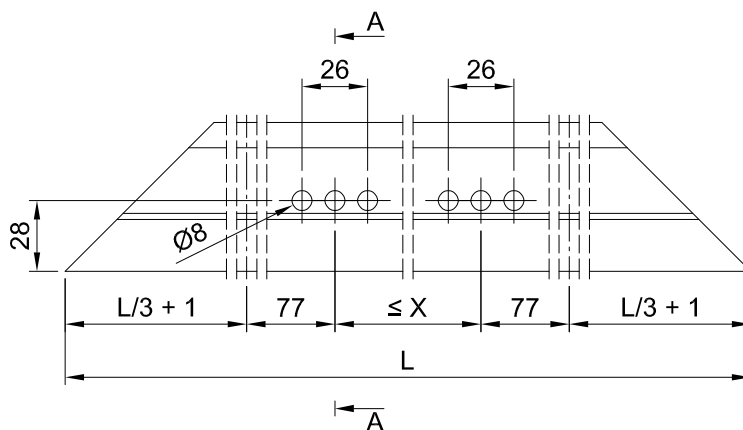
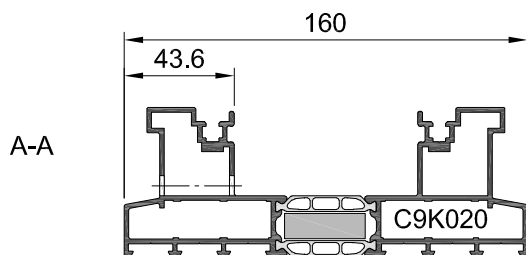
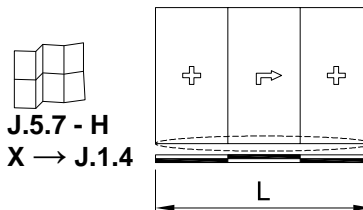

## 2-BINARI FISSO-ALZANTE-SCORREVOLE-FISSO TAGLI 45°

### C9K020 LAVORAZIONE DRENAGGIO - B

5 / 12

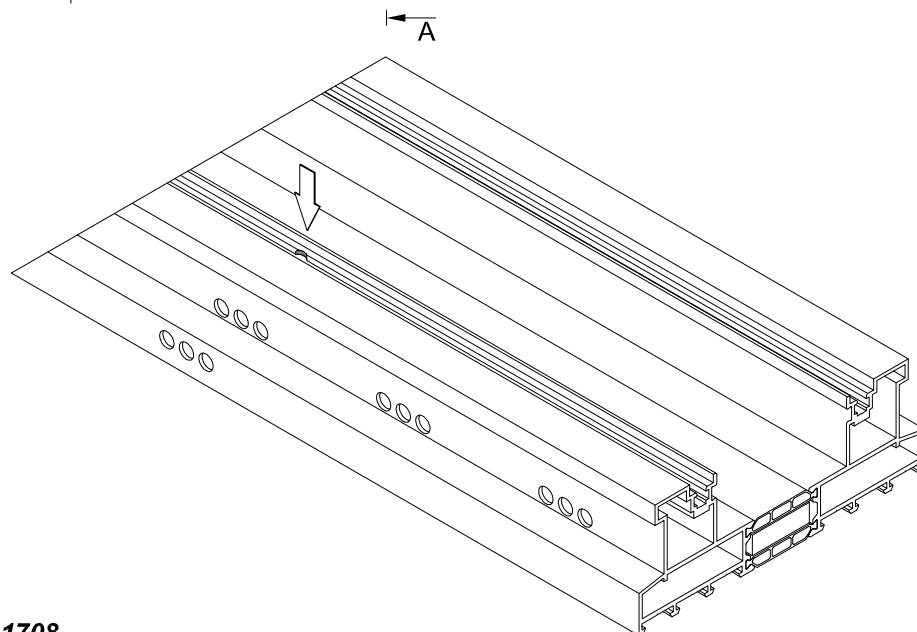
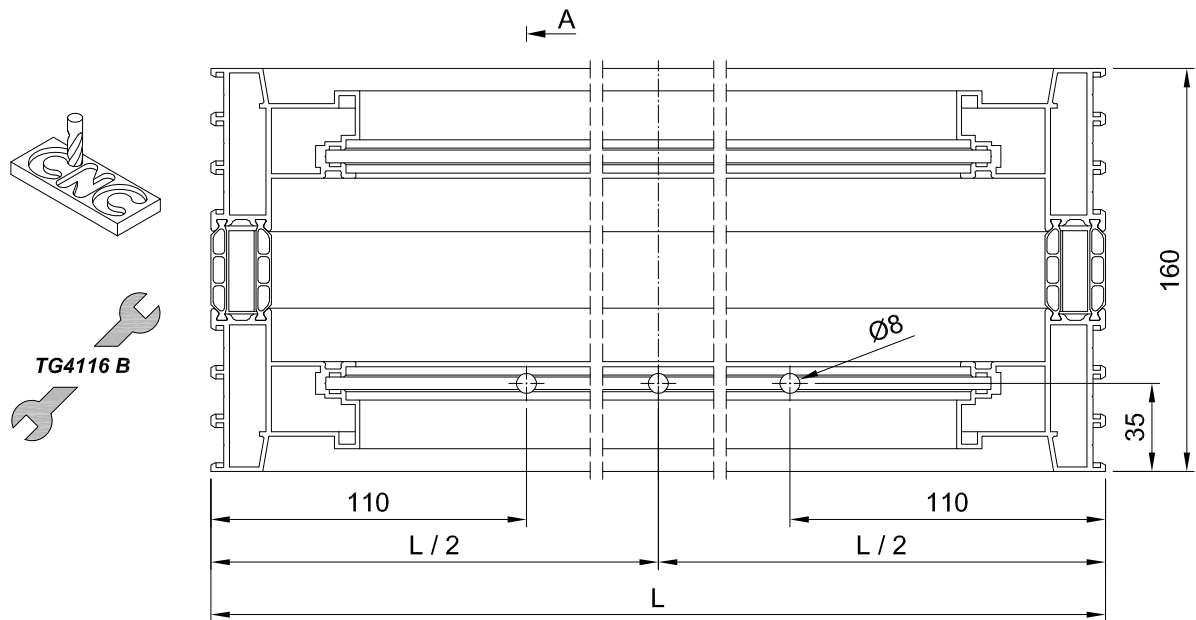
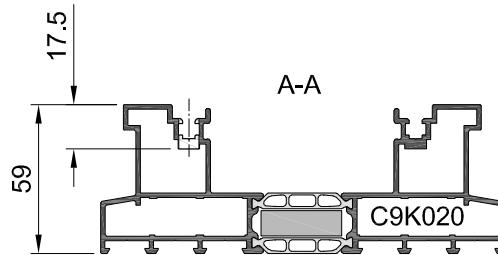
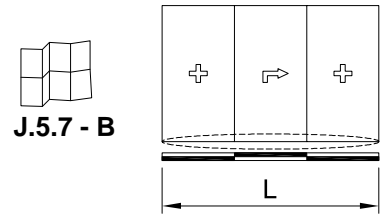

**C9K020 LAVORAZIONE DRENAGGIO - A**

6 / 12

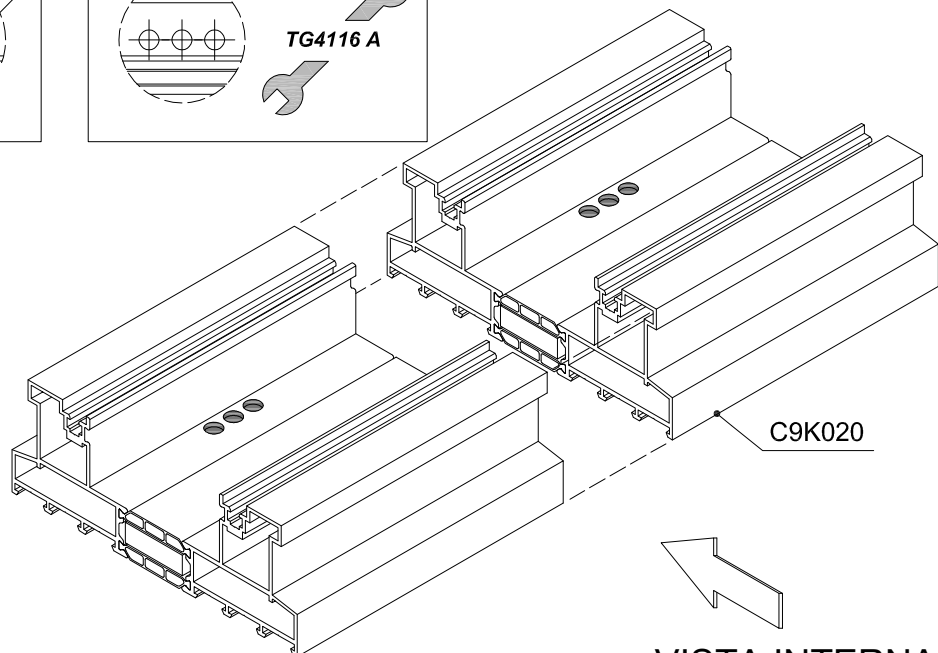
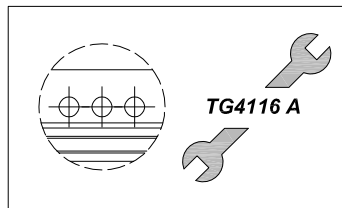
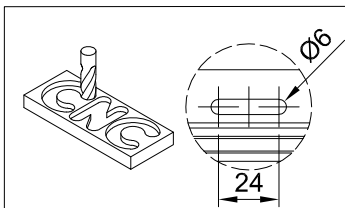
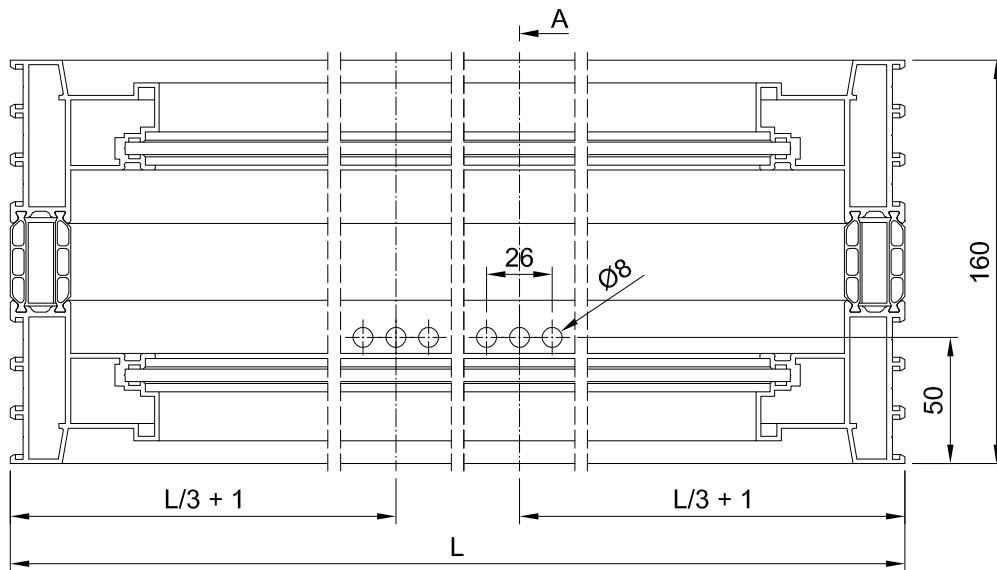
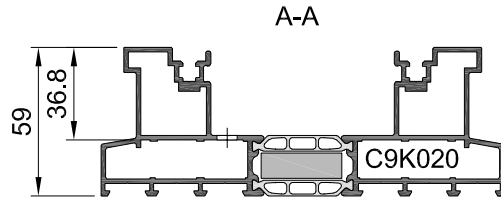
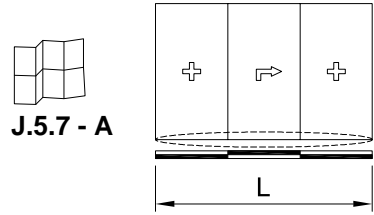

VISTA INTERNA



## 2-BINARI FISSO-ALZANTE-SCORREVOLE-FISSO TAGLI 45°

### C9K020 LAVORAZIONE DRENAGGIO - G

7 / 12



J.5.7 - G  
J.5.18

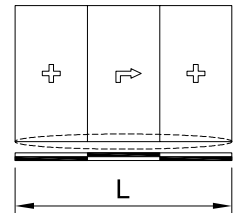

A-A

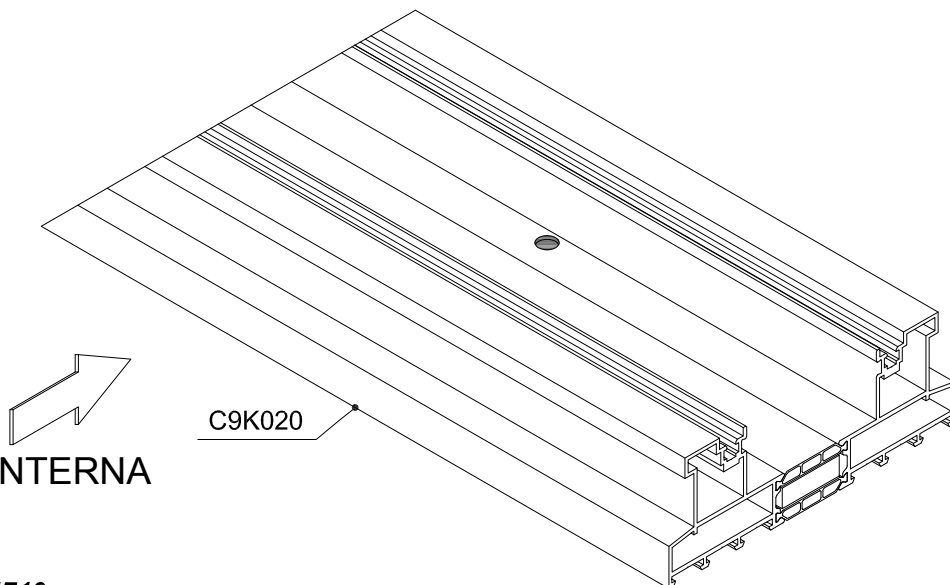
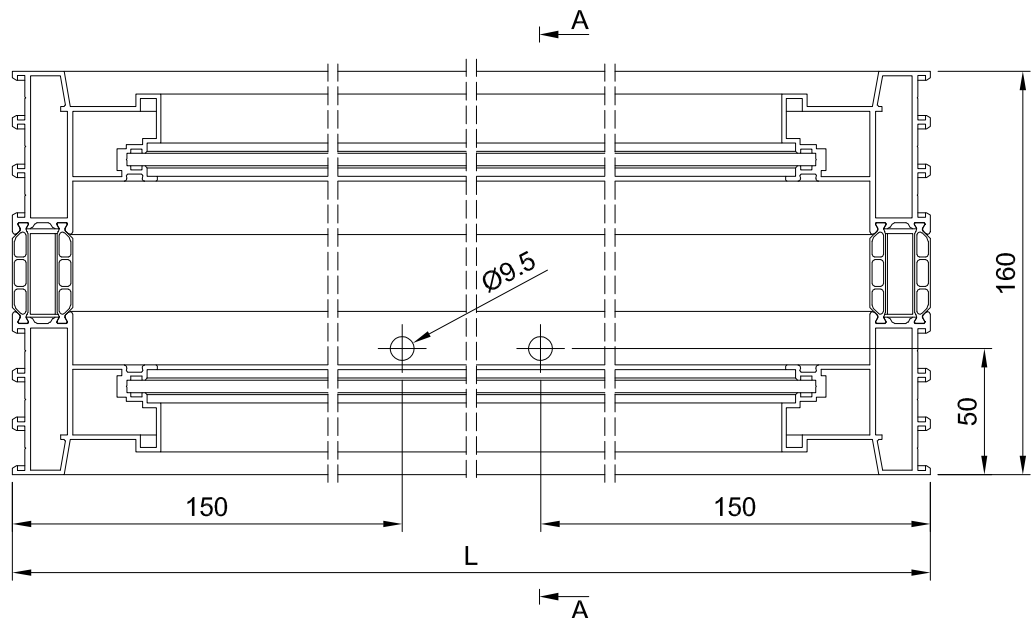
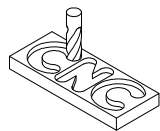
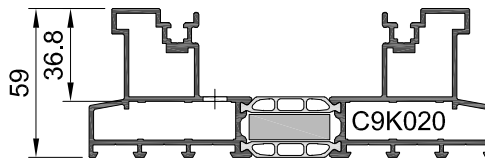

VISTA INTERNA

C160-ASS-1710

**C9K020 LAVORAZIONE DRENAGGIO - M**

8 / 12

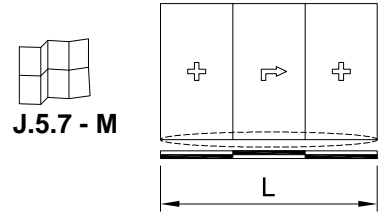

J.5.7 - M

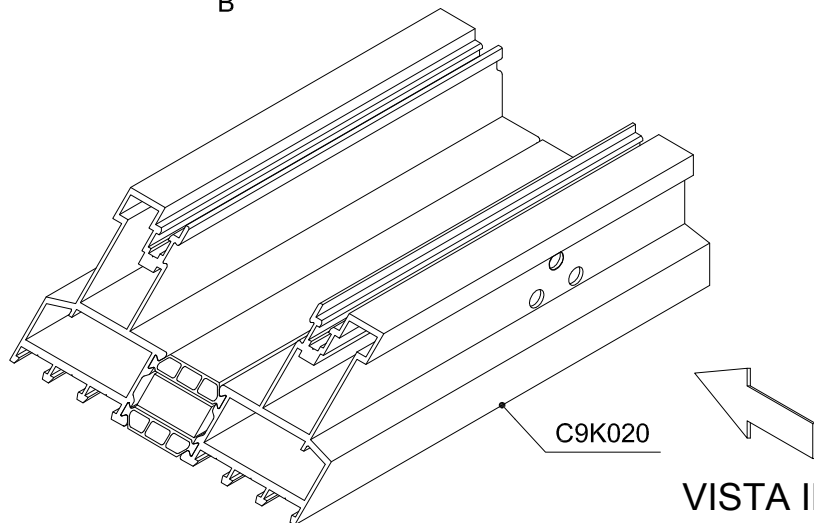
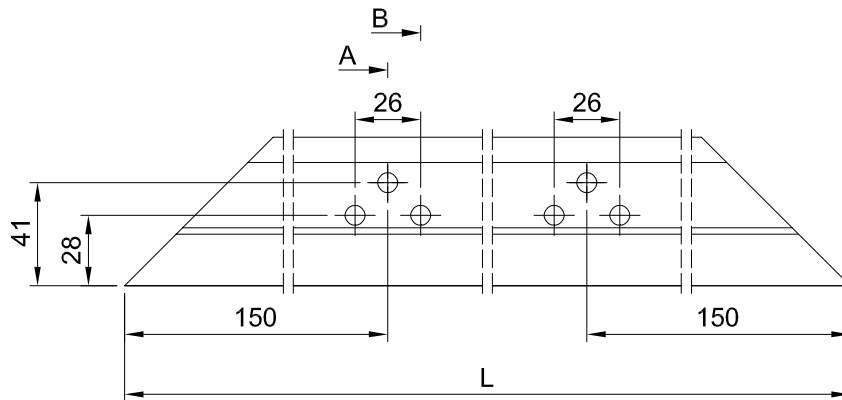
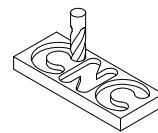
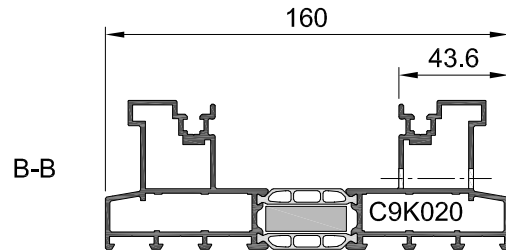
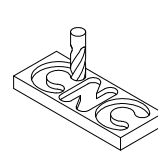
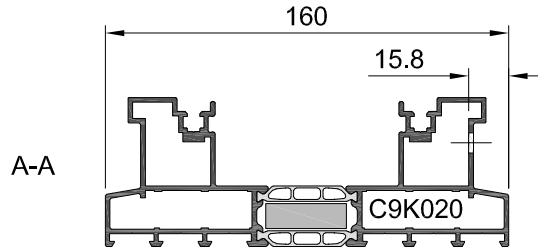

VISTA INTERNA

### KU2028 LAVORAZIONE DRENAGGIO - K1

9 / 12

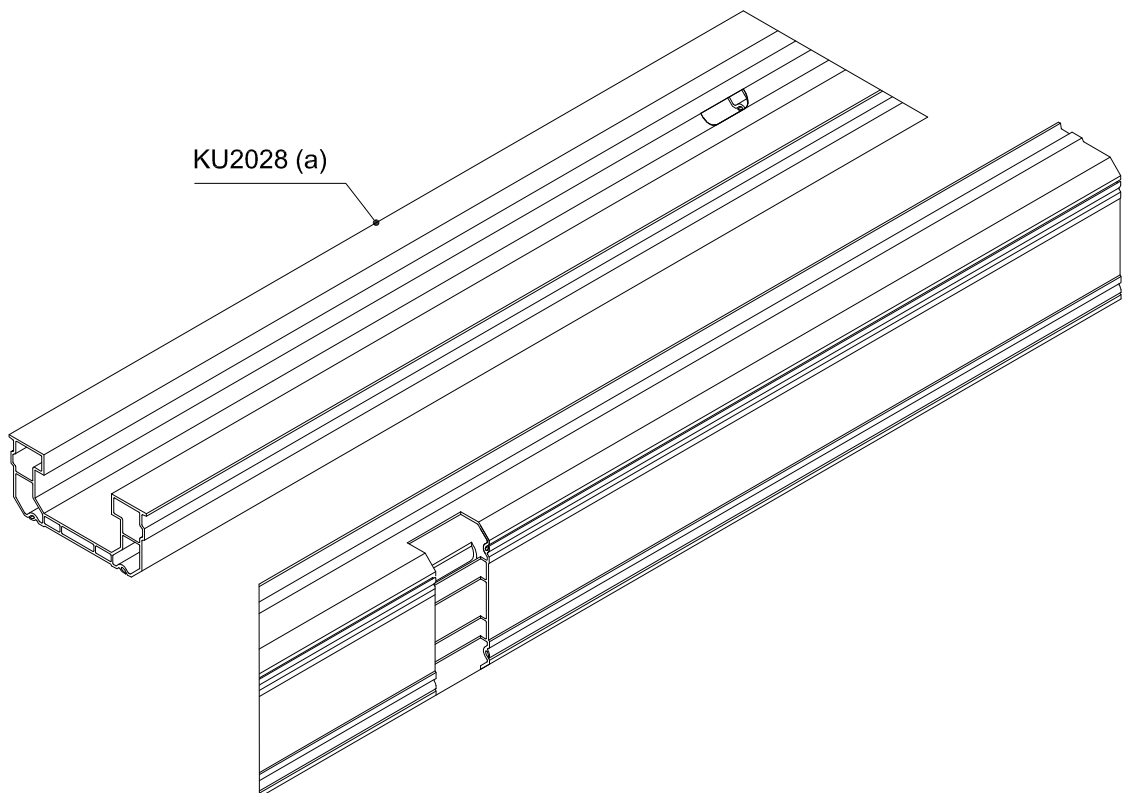
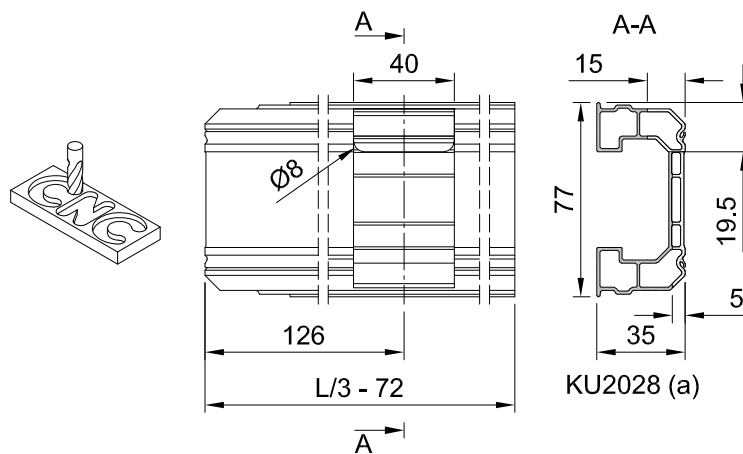
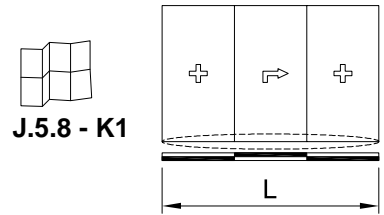

**KU2028 LAVORAZIONE DRENAGGIO - K2**

10 / 12



**J.5.8 - K2**

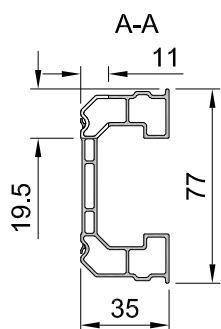
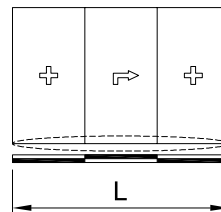

**KU2028 (b)**

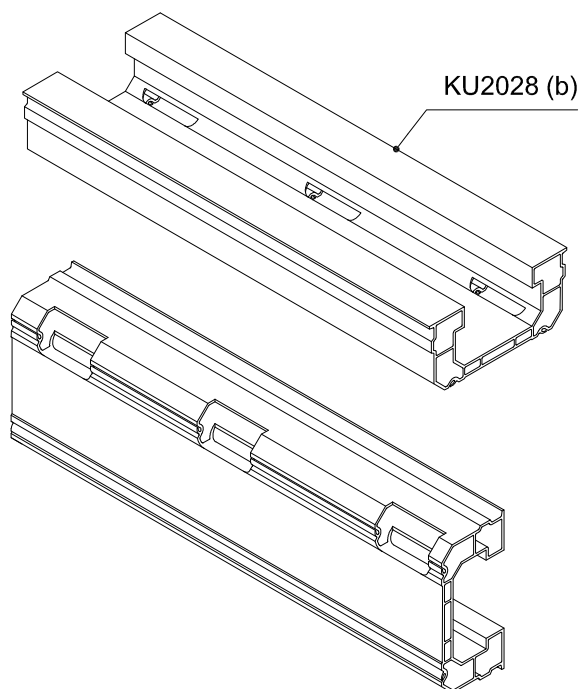
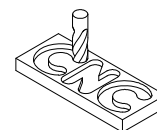
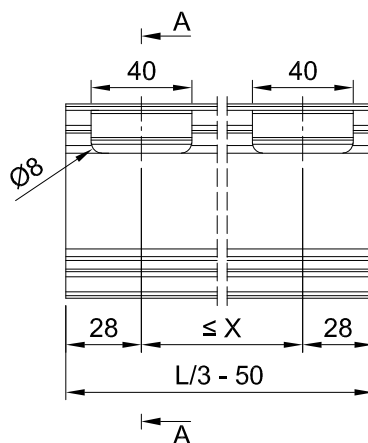

## 2-BINARI FISSO-ALZANTE-SCORREVOLE-FISSO TAGLI 45°

### KU2028 LAVORAZIONE DRENAGGIO - K3

11 / 12

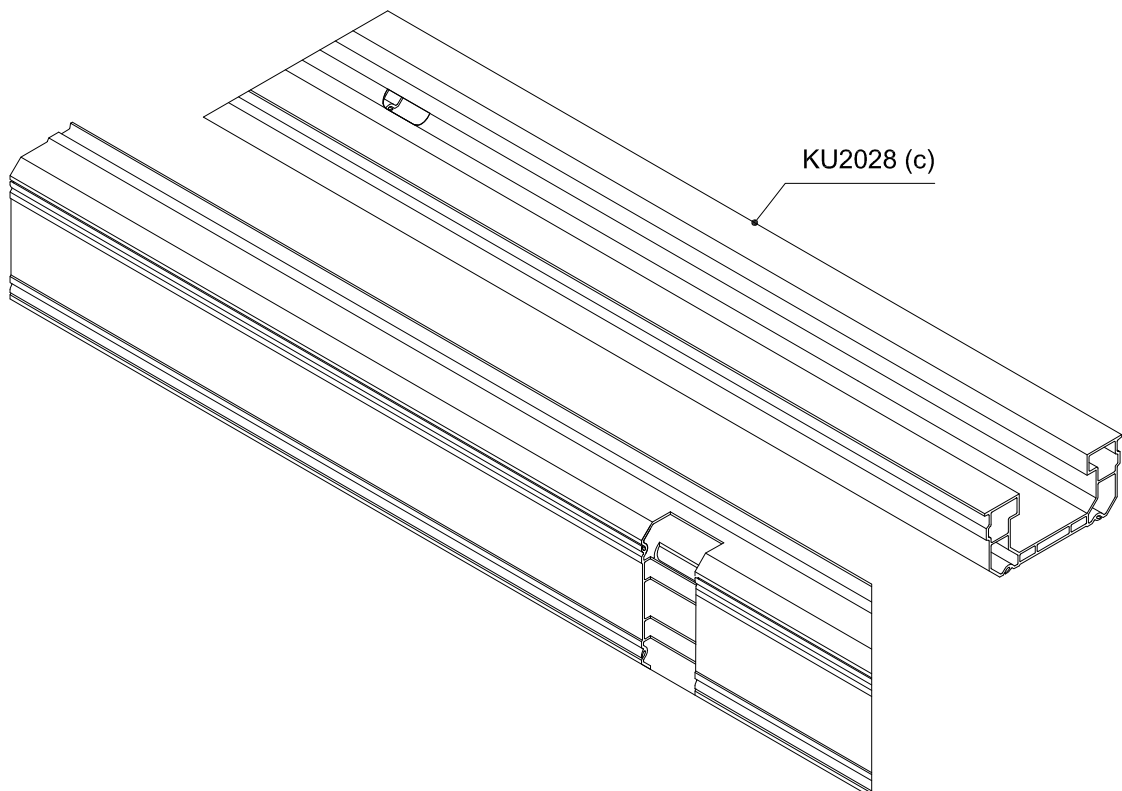
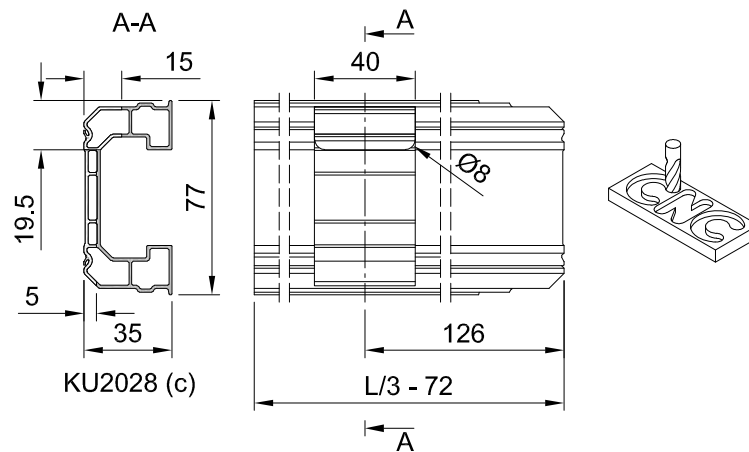
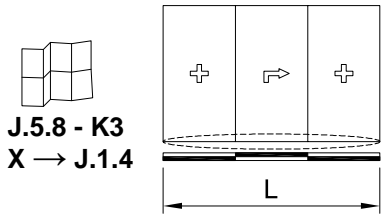

**ASSEMBLAGGIO VS0107 E KU2028 SU C9K020 PROFILATO INFERIORE**

12 / 12

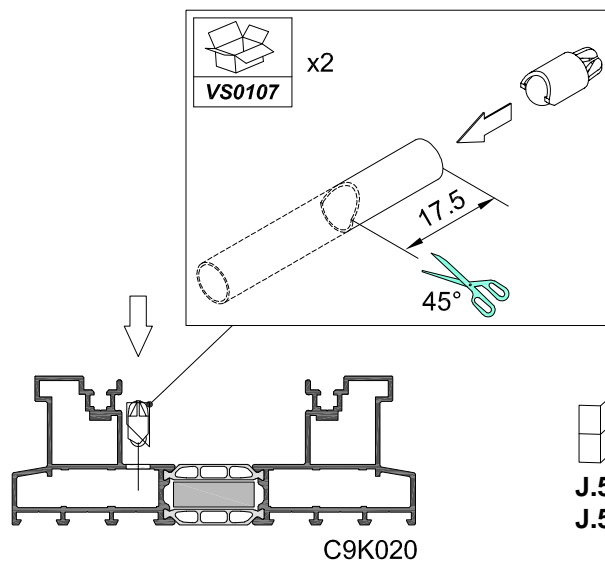
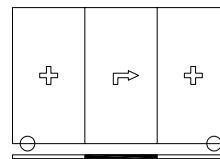

  
**J.5.7 - E**  
**J.5.13**

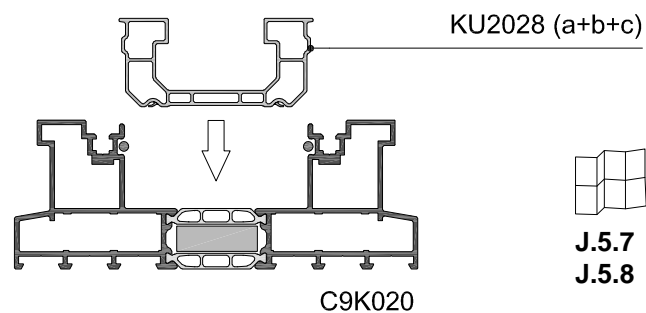
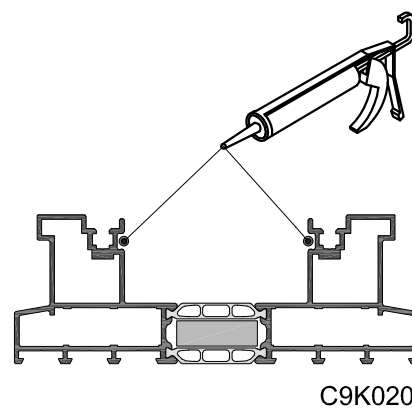
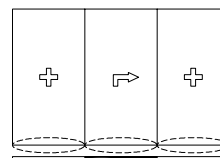

  
**J.5.7**  
**J.5.8**

## 2-BINARI FISSO-ALZANTE-SCORREVOLE-FISSO TAGLI 45°

### ASSEMBLAGGIO TAPPO CENTRALE CO1105 PROFILATO INFERIORE

1 / 2



J.5.2 - D  
J.5.32

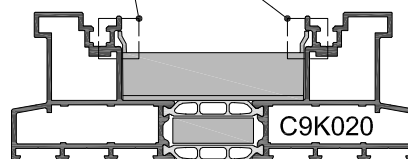
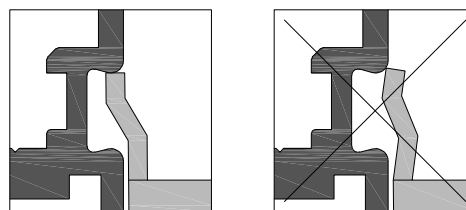
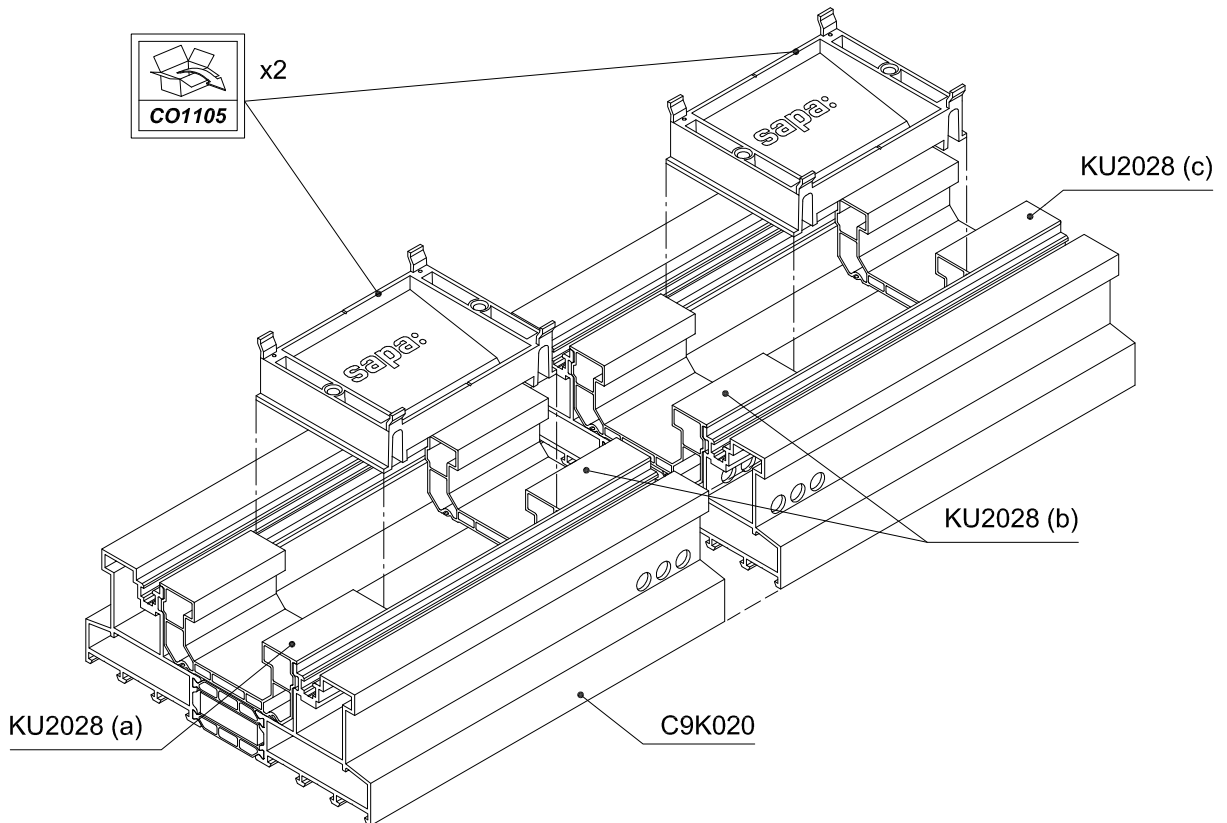
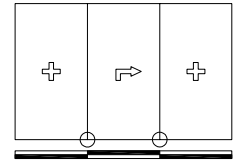

**ASSEMBLAGGIO TAPPO CENTRALE CO1105 PROFILATO INFERIORE**

2 / 2



J.5.2 - D  
J.5.32

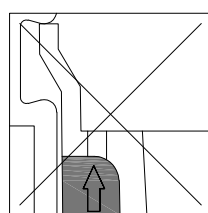
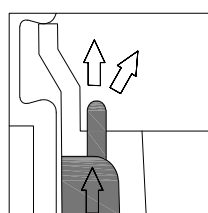
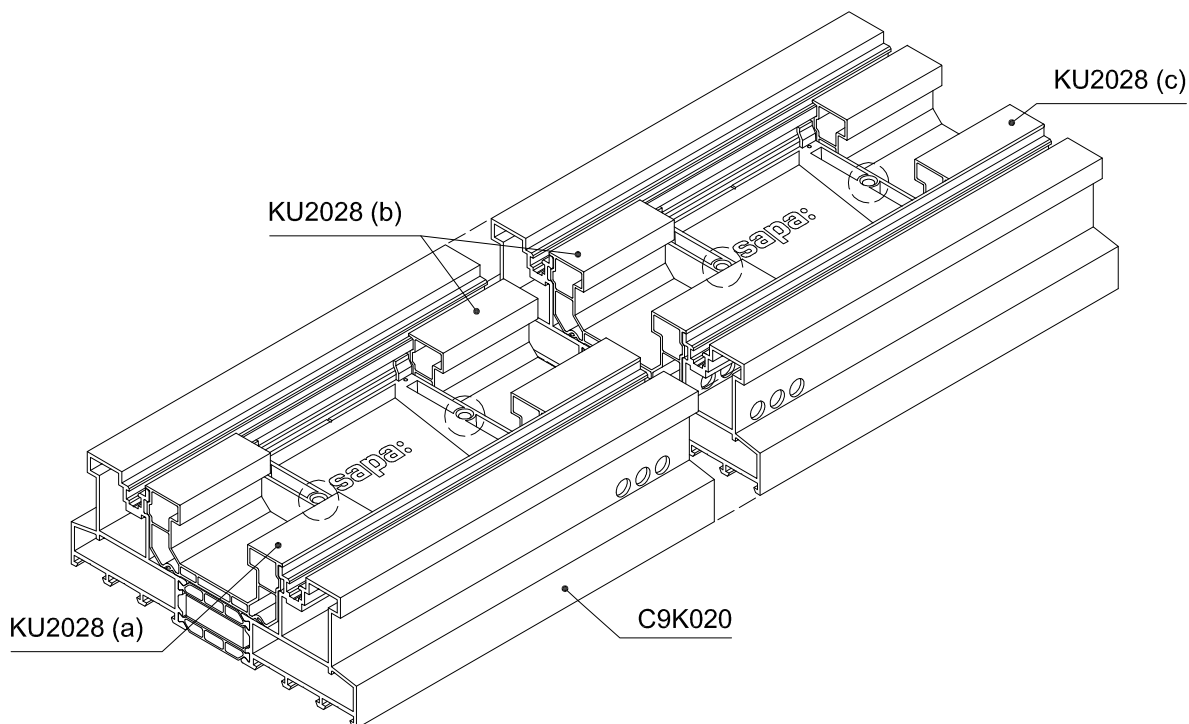
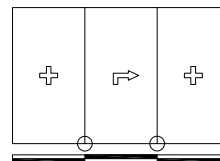

silicone

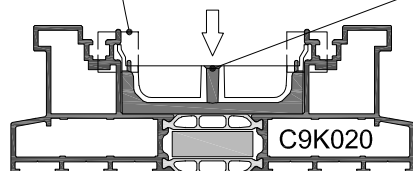
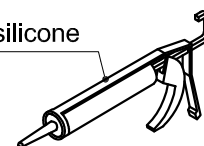



## 2-BINARI FISSO-ALZANTE-SCORREVOLE-FISSO TAGLI 45°

SIGILLATURA PROFILATO INFERIORE C9K020 CON VS9950 E VS9951

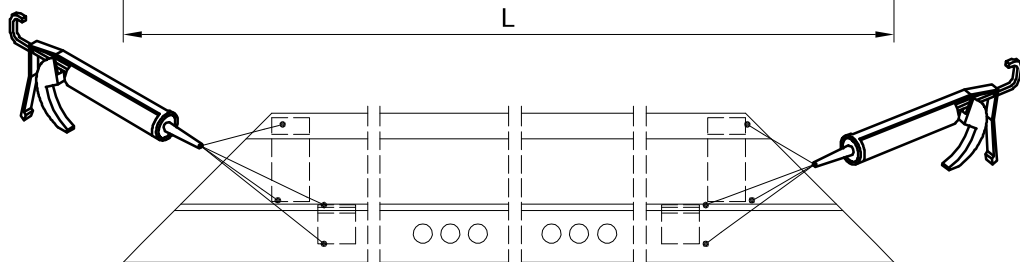
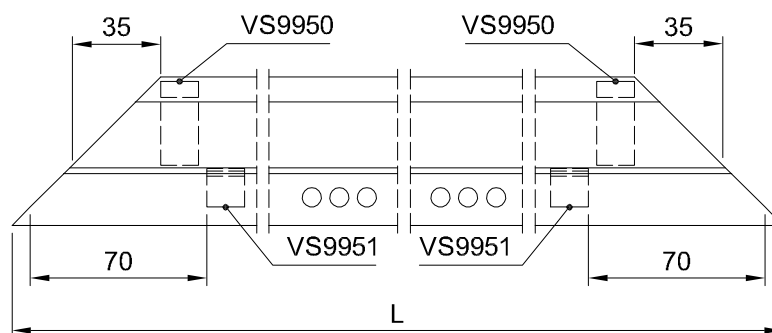
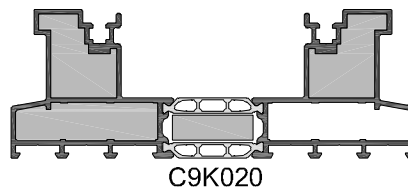
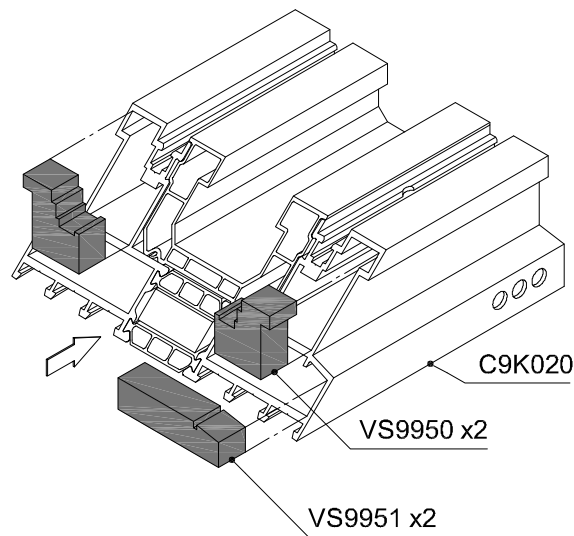
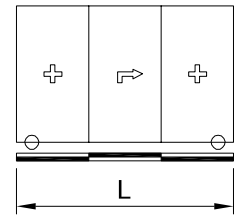

**ASSEMBLAGGIO TAPPO CENTRALE CO1111 PROFILATO SUPERIORE C9K020**



J.5.2 - E  
J.11.17

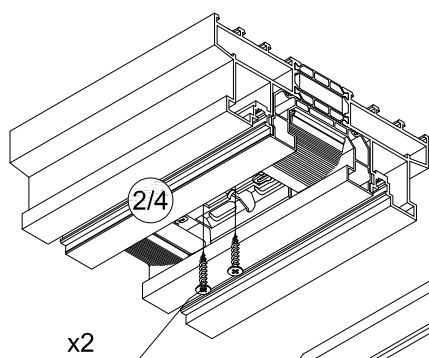
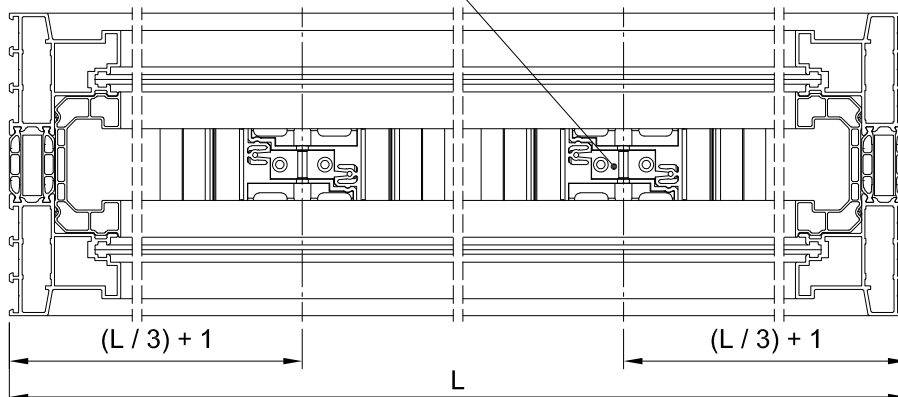
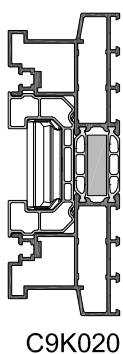
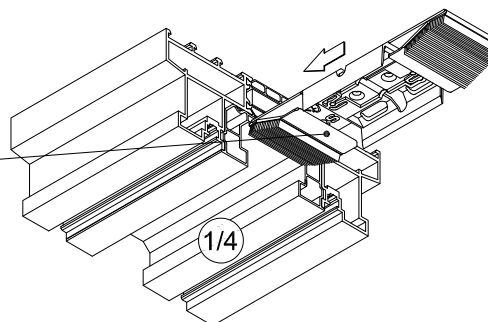
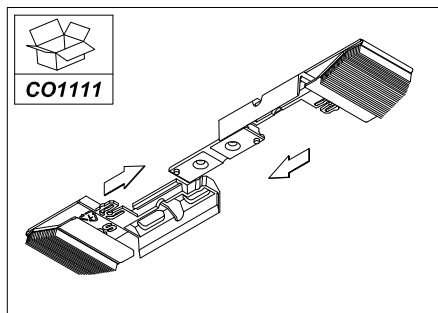
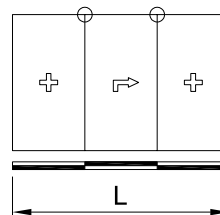

x2

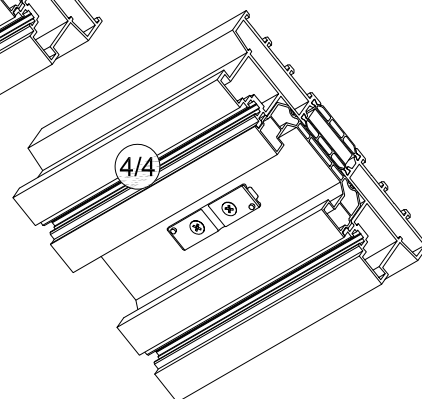
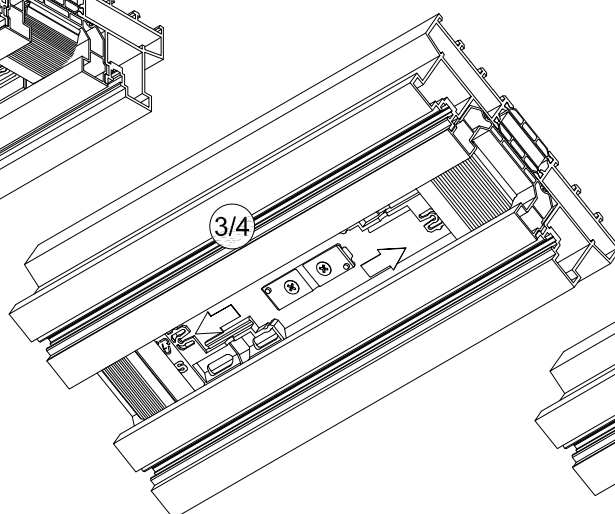

**C160-ASS-1702**

### ASSEMBLAGGIO PROFILATI TELAI CON SQUADRETTE

1 / 3



J.5.2 - A  
J.5.5

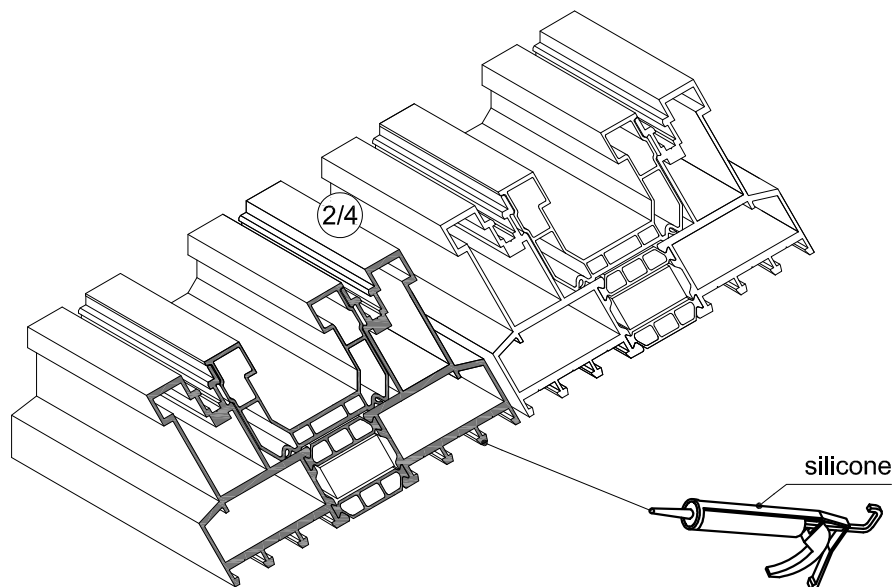
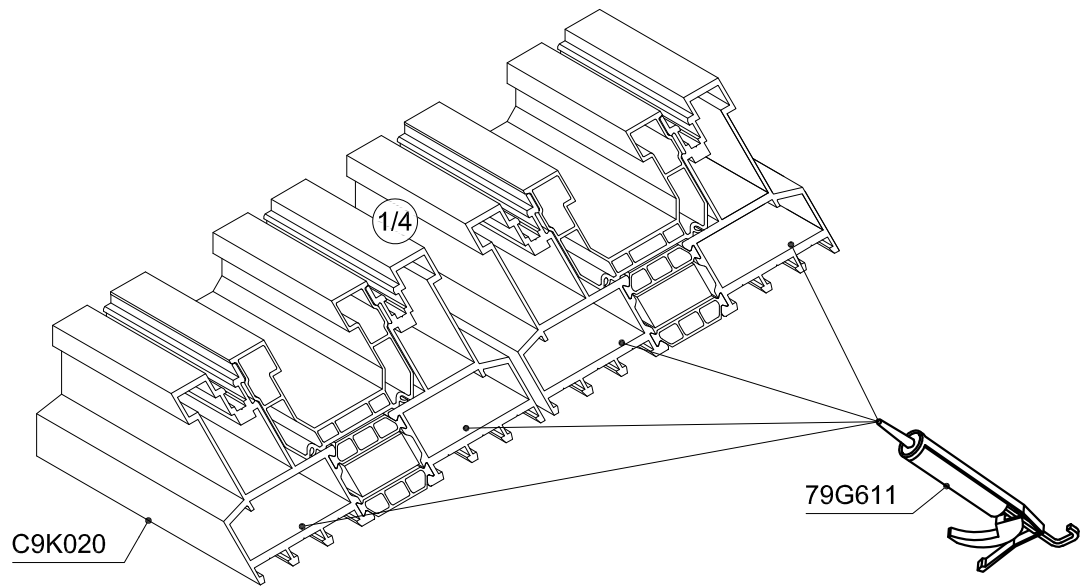
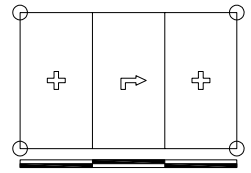

**ASSEMBLAGGIO PROFILATI TELAI CON SQUADRETTE**

2 / 3



J.5.2 - A  
J.5.5

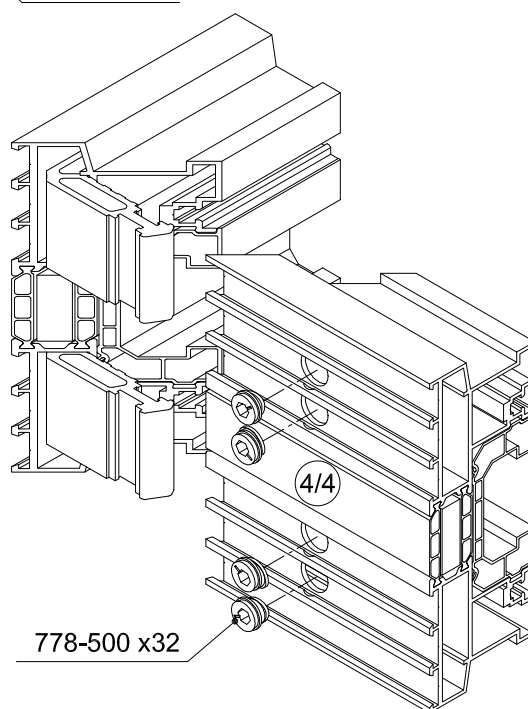
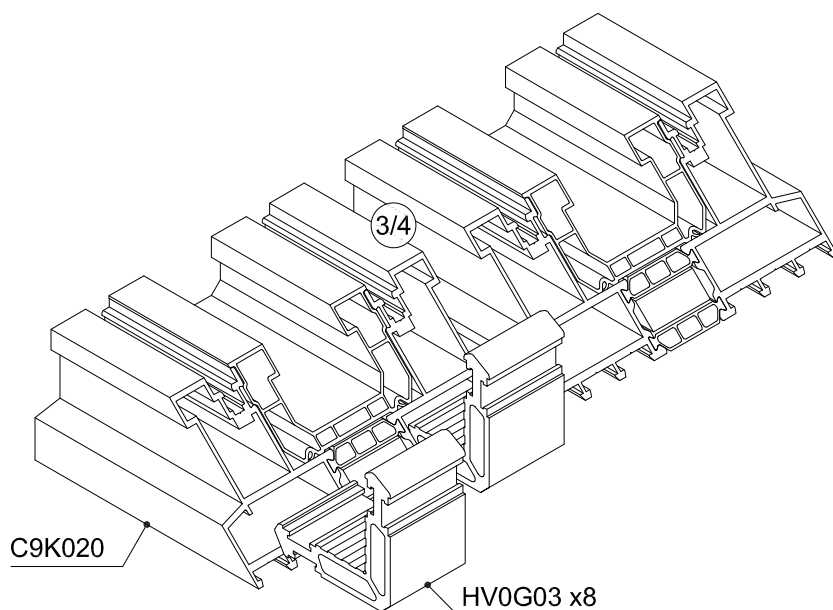
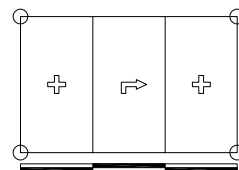

### ASSEMBLAGGIO PROFILATI TELAI CON SQUADRETTE

3 / 3



J.5.2 - A  
J.5.5

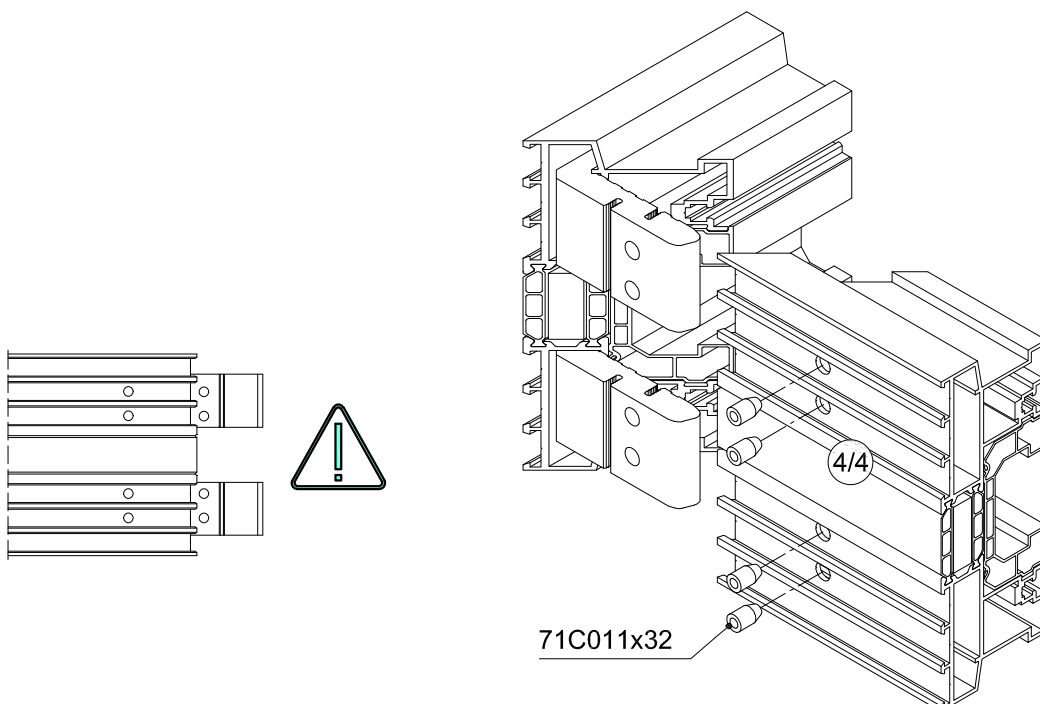
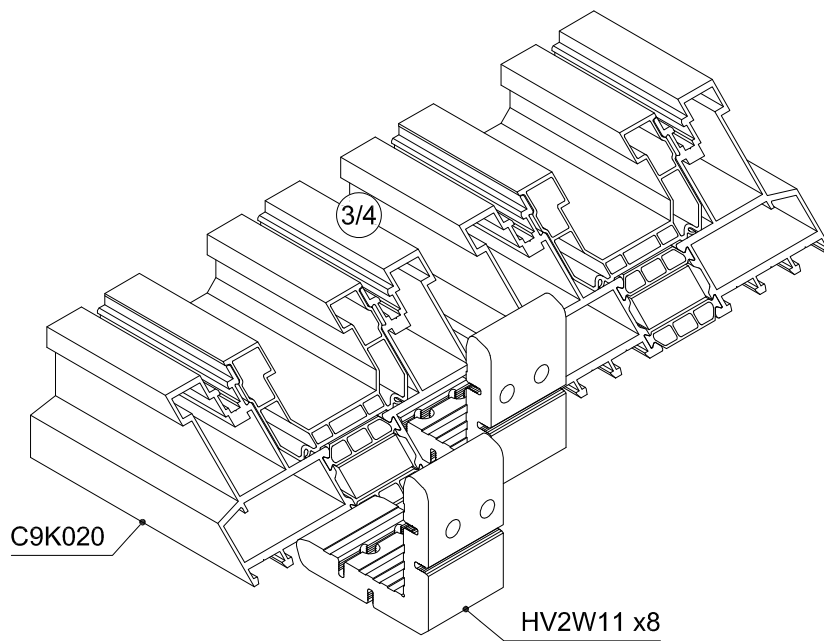
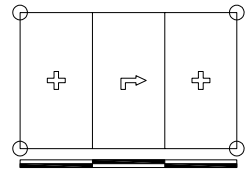

**ASSEMBLAGGIO CAPPETTA DI DRENAGGIO C9A003**



J.5.2 - B  
J.5.6

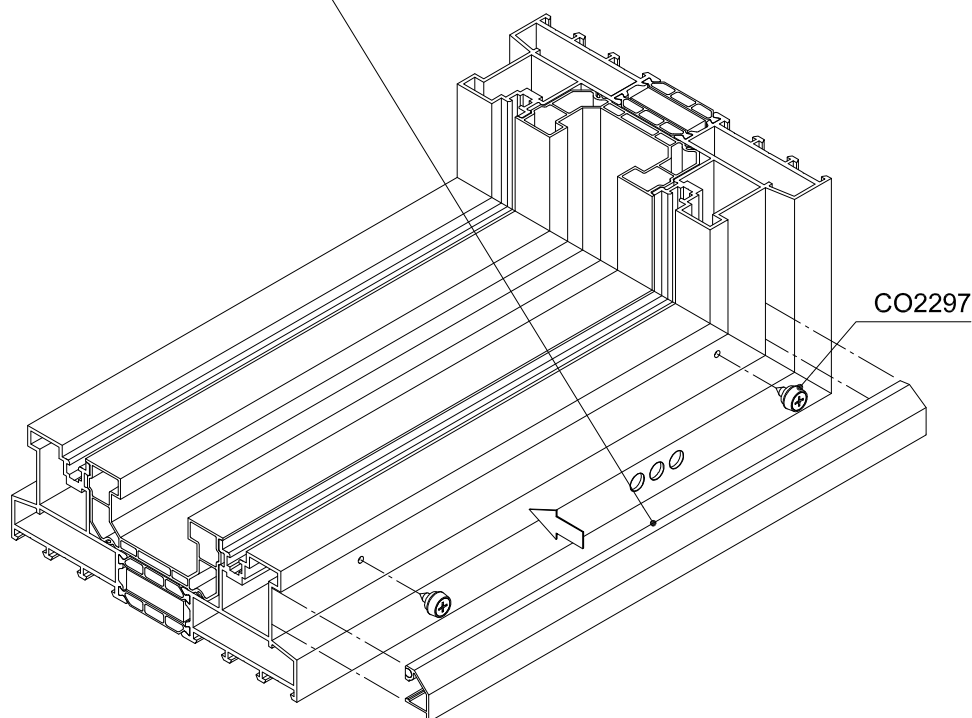
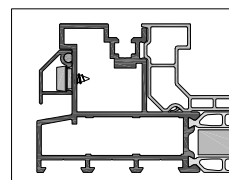
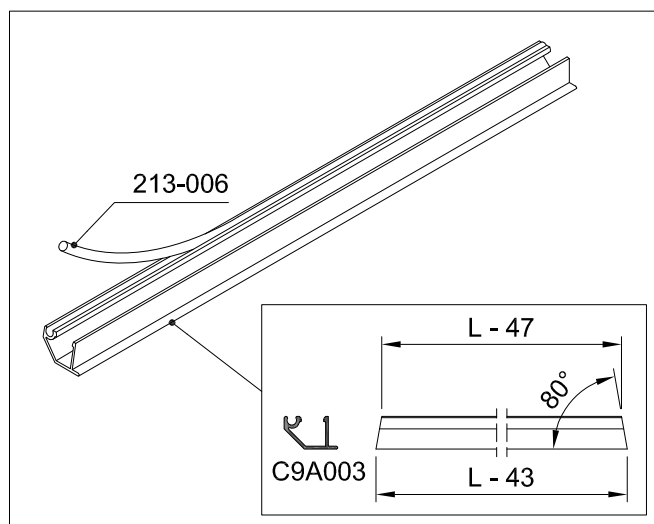
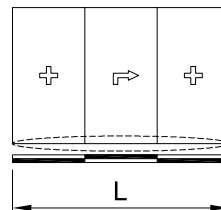

## 2-BINARI FISSO-ALZANTE-SCORREVOLE-FISSO TAGLI 45°

### PREPARAZIONE C9A004 + VS2404

1 / 3

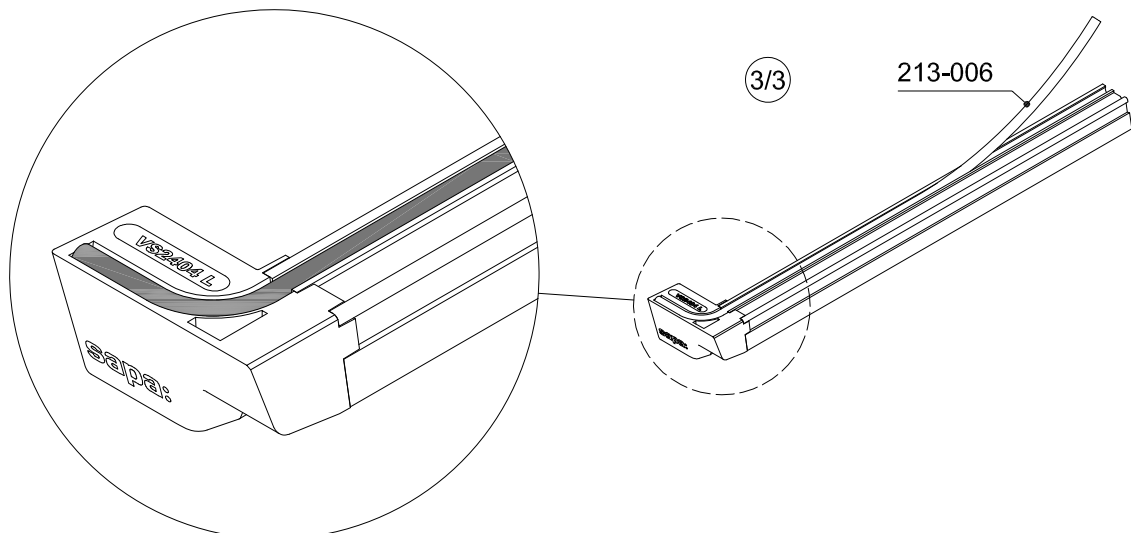
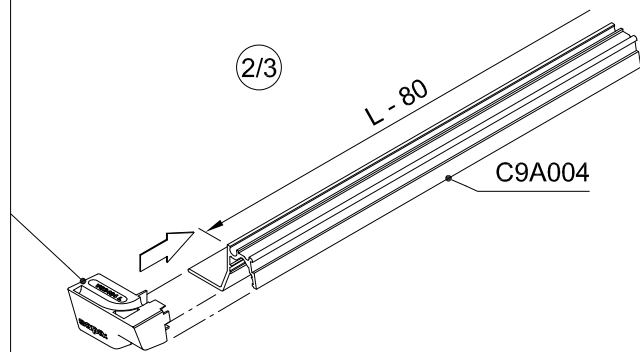
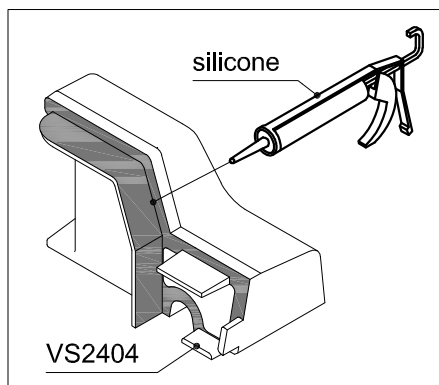
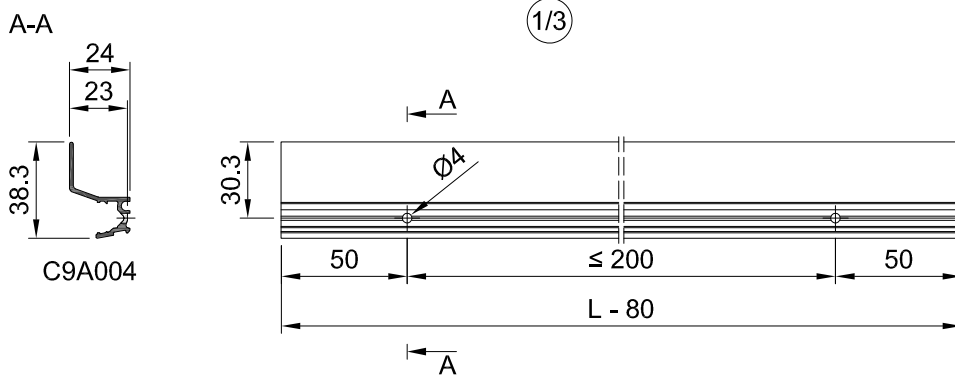
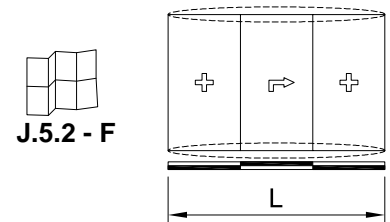

**ASSEMBLAGGIO C9A004 + VS2404**

2 / 3



J.5.2 - F

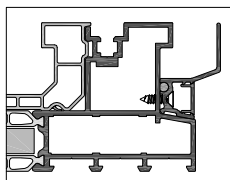
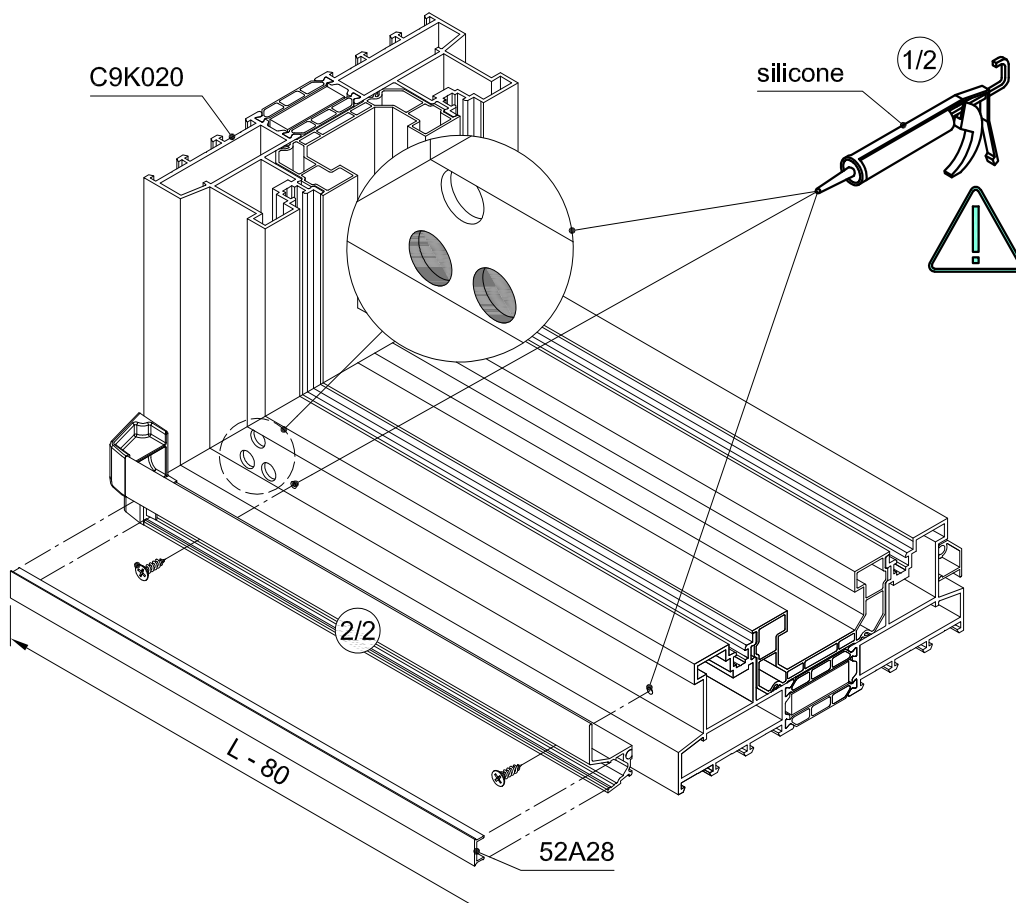
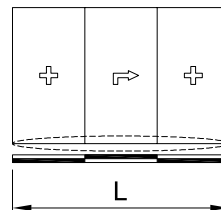



### ASSEMBLAGGIO C9A004 + VS2404 COVER - OPTIONAL

3 / 3

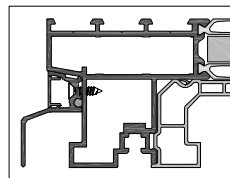
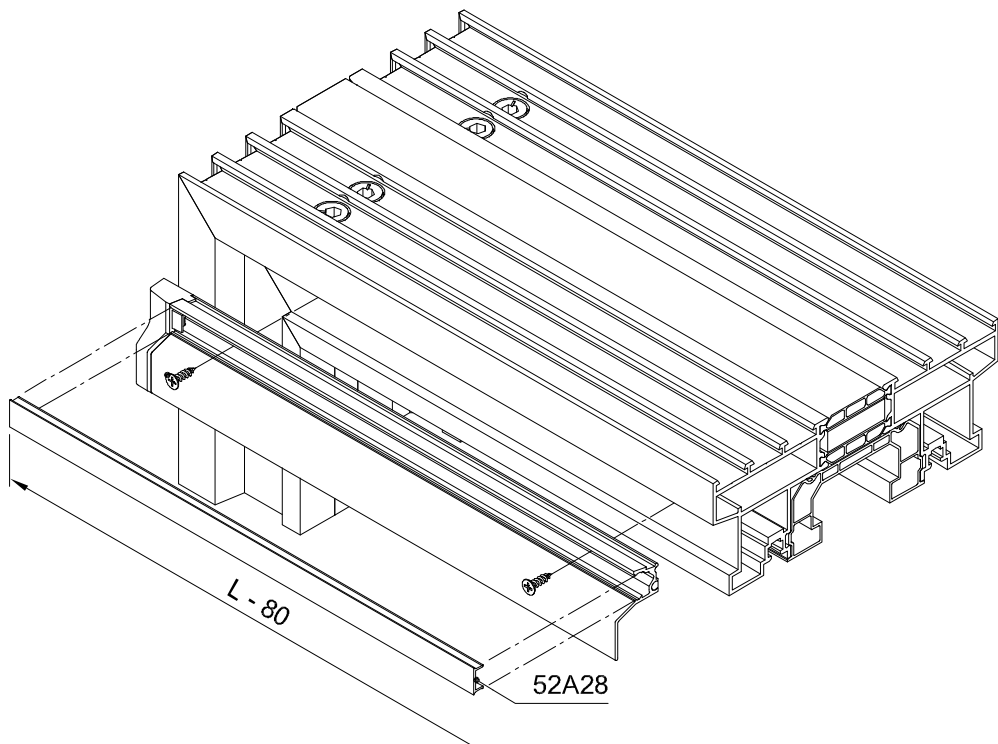
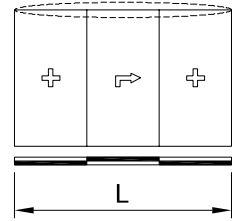

**ASSEMBLAGGIO CO1103 E ZB0038**

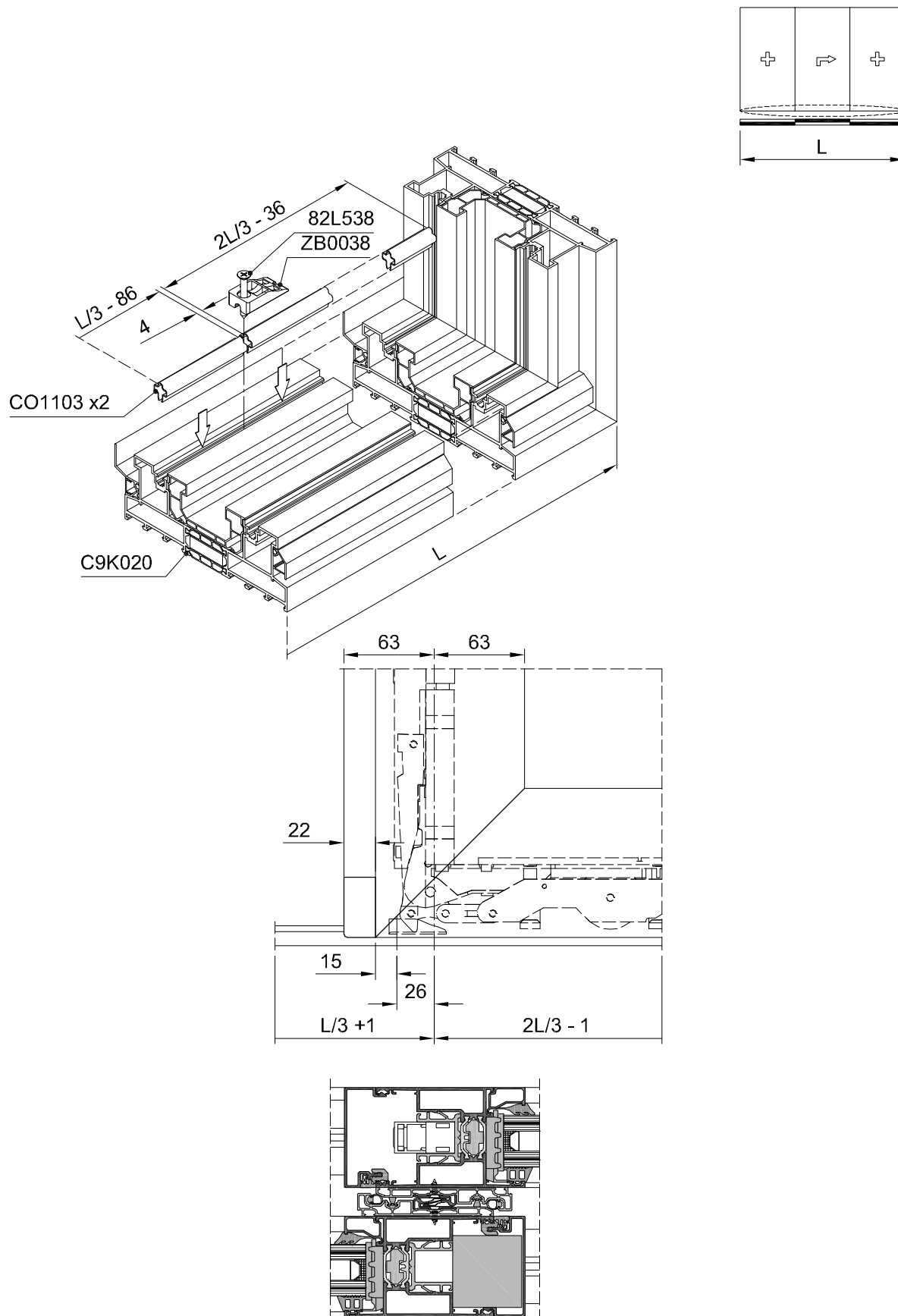

### ASSEMBLAGGIO GUARNIZIONE DI FINITURA RU9704

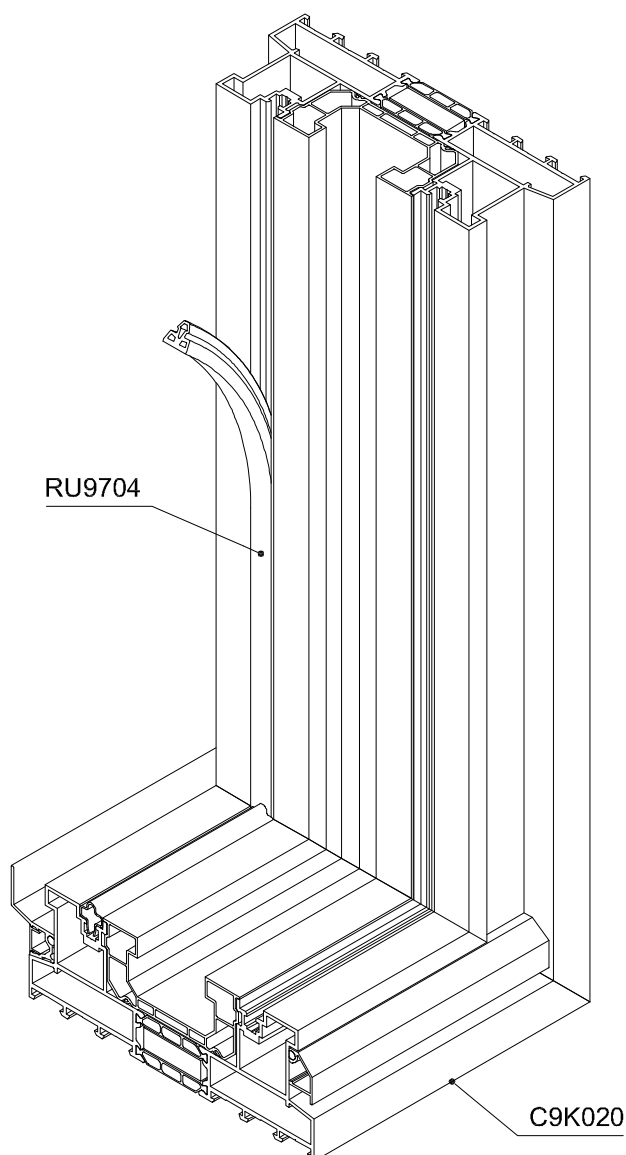
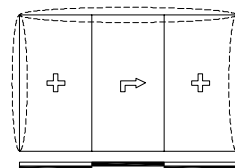

### PROFILATO DI FINITURA C9A020 CON C9K020

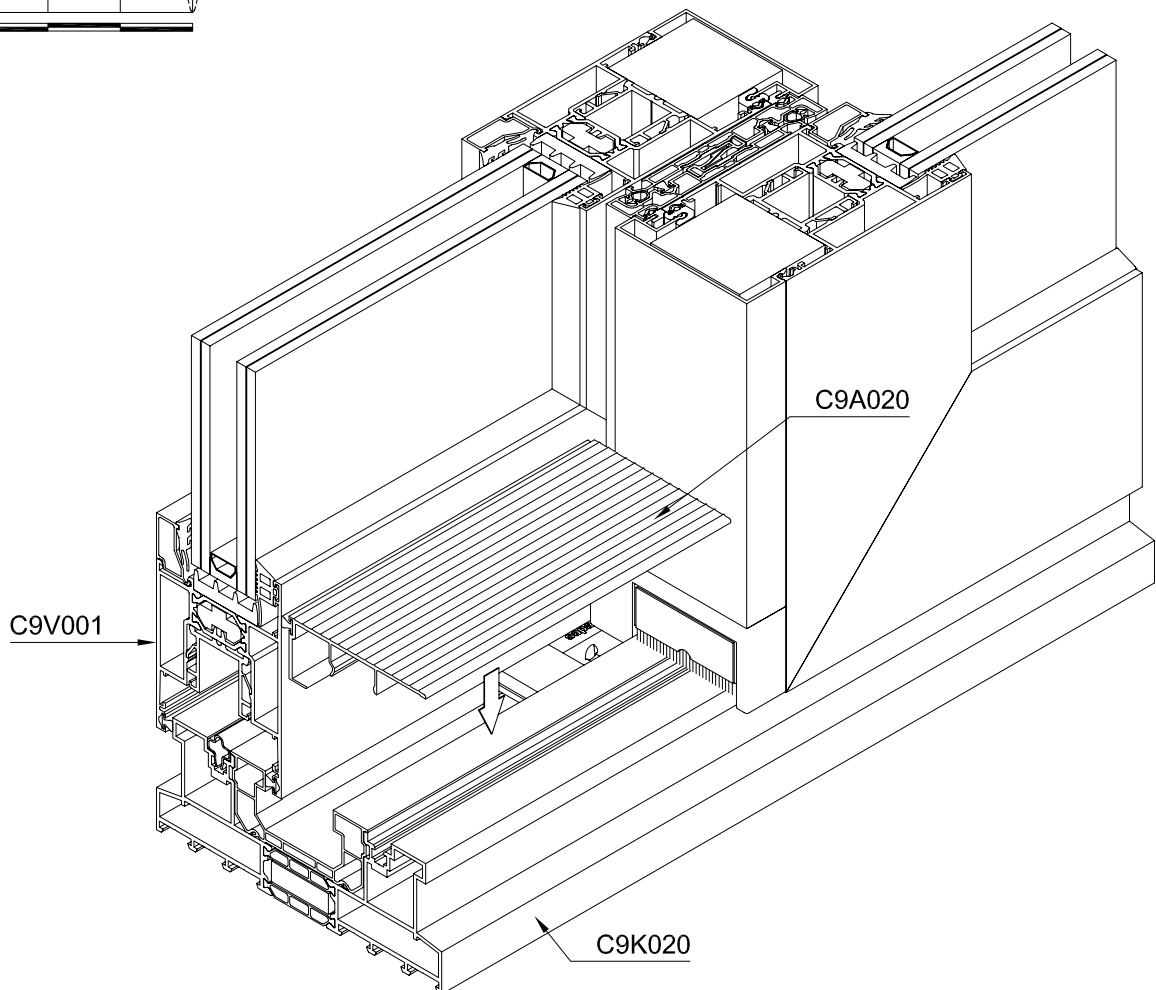
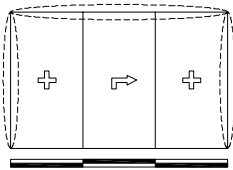
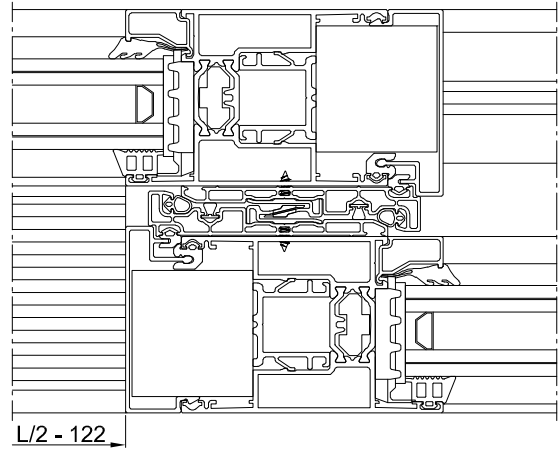
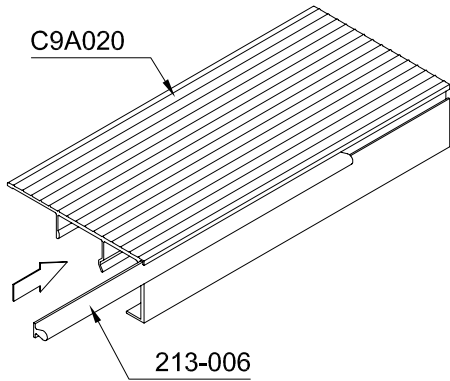



**ASSEMBLAGGIO TAPPO CENTRALE CO1105 PROFILATO INFERIORE**



J.5.2 - D  
J.5.19

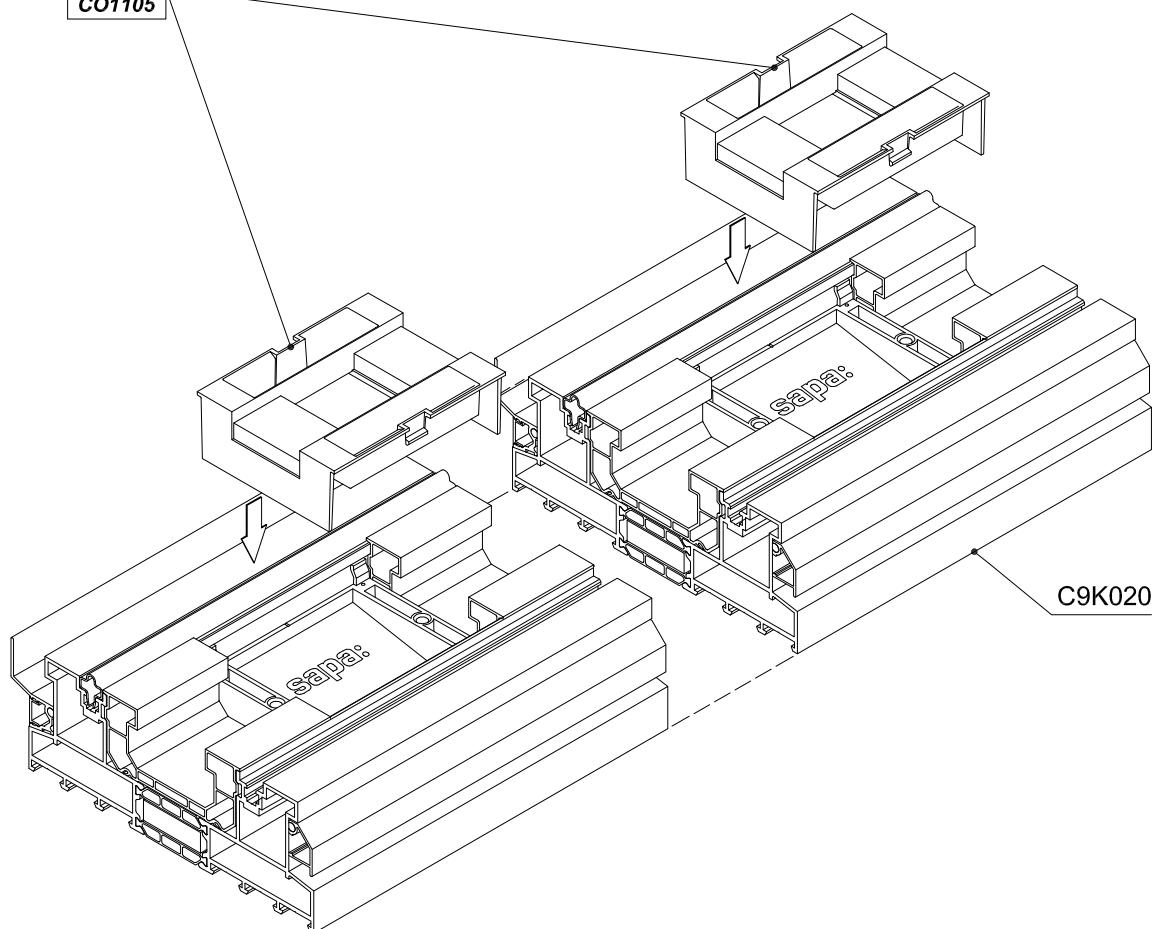
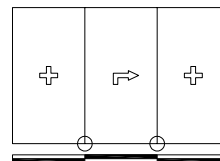

### PANORAMICA ASSEMBLAGGIO

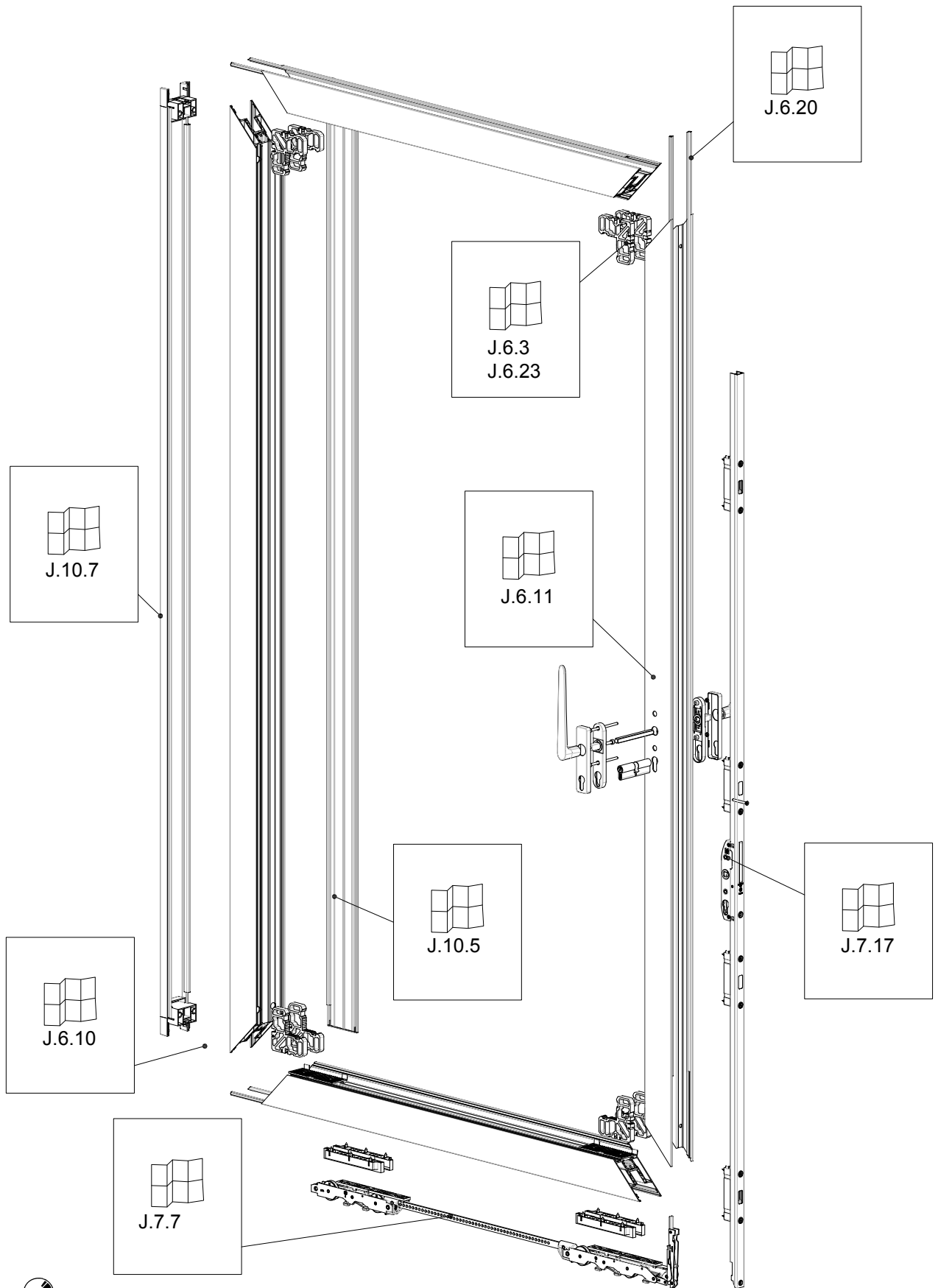

 C160-TYP-511

## CONTENUTO

Preparazione ante.....	J.7.1
Panoramica assemblaggio.....	J.7.1
Contenuto.....	J.7.2



Taglio profilati anta e installazione BT6000.....	J.7.3
---	-------



Lavorazione squadrette profilati ante.....	J.7.4
Lavorazione del C9V051 profilato anta effetto 'bi-metal'.....	J.7.6
Lavorazione drenaggio profilata anta.....	J.7.7
Panoramica lavorazione paracolpi su profilato anta.....	J.7.8
Lavorazione paracolpi su profilato anta.....	J.7.9
Lavorazione profilato anta per tappo 1/2.....	J.7.10
Lavorazione profilato anta per ferramenta alzante-scorrevole - panoramica.....	J.7.11
Lavorazione profilato anta per ferramenta alzante-scorrevole - panoramica.....	J.7.14
Lavorazione profilato anta per ferramenta alzante-scorrevole.....	J.7.16



Installazione guarnizione RU0099 per alzante-scorrevole.....	J.7.20
Installazione guarnizione RU0099 per alzante-scorrevole - 3-binari.....	J.7.21
Assemblaggio profilato anta con squadrette.....	J.7.23



### TAGLIO PROFILATI ANTA E INSTALLAZIONE BT6000

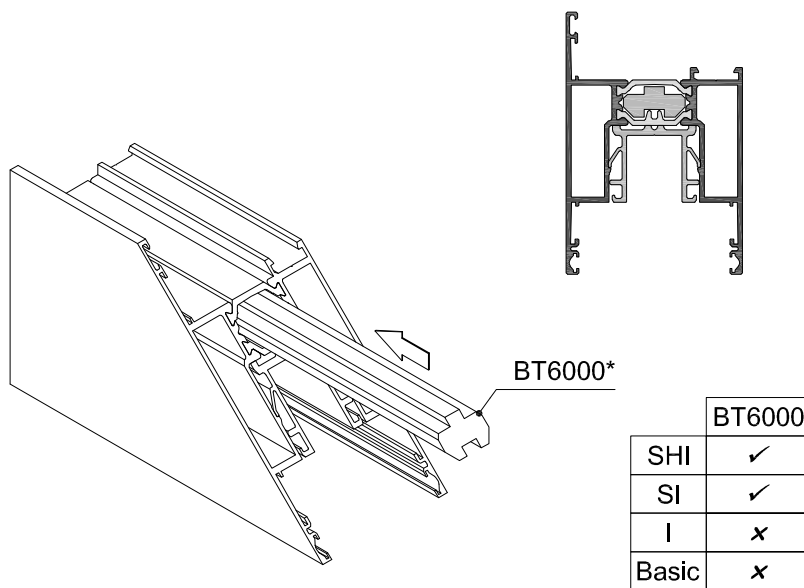
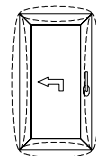
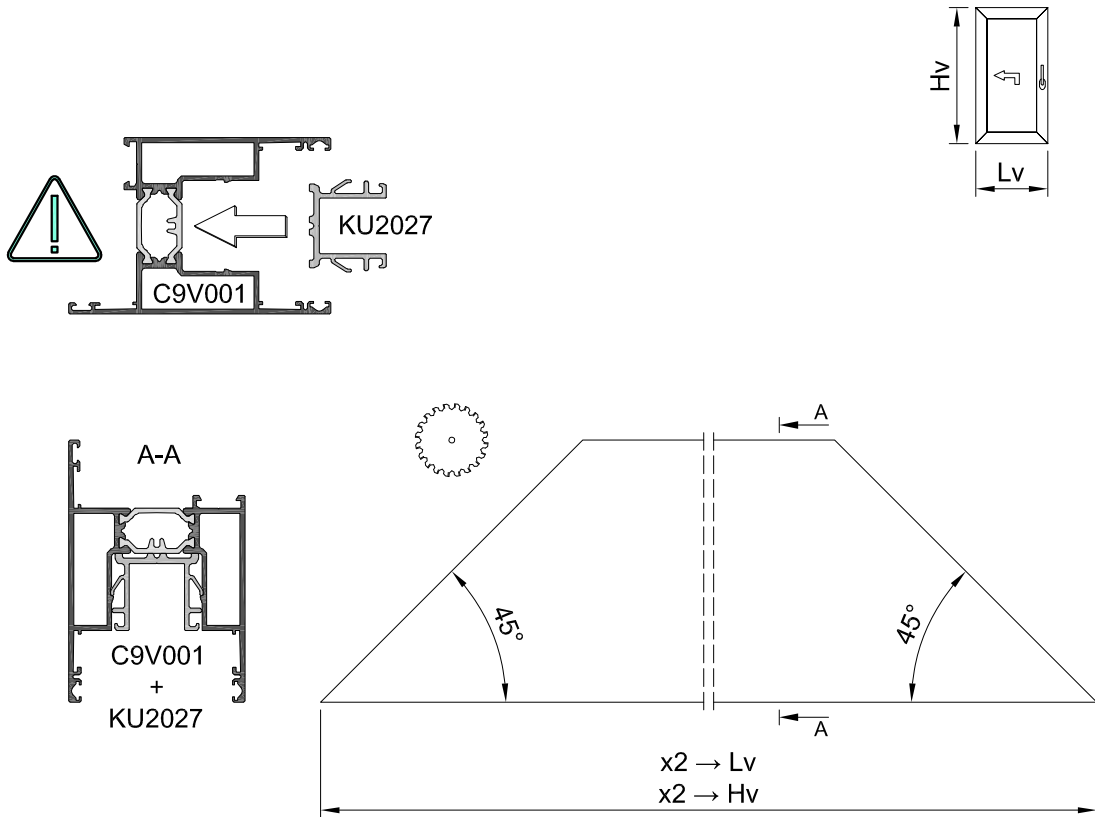

	BT6000
SHI	✓
SI	✓
I	x
Basic	x

**PREPARAZIONE ANTE**

**LAVORAZIONE SQUADRETTE PROFILATI ANTE**

1 / 2

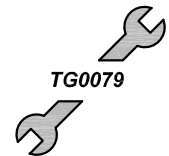
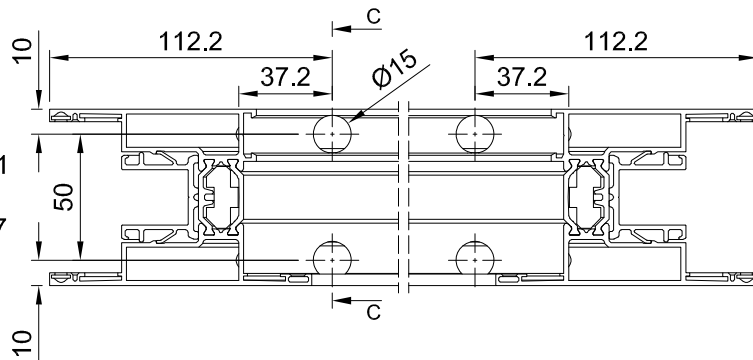
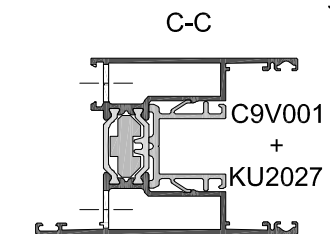
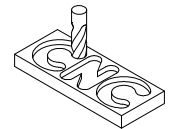
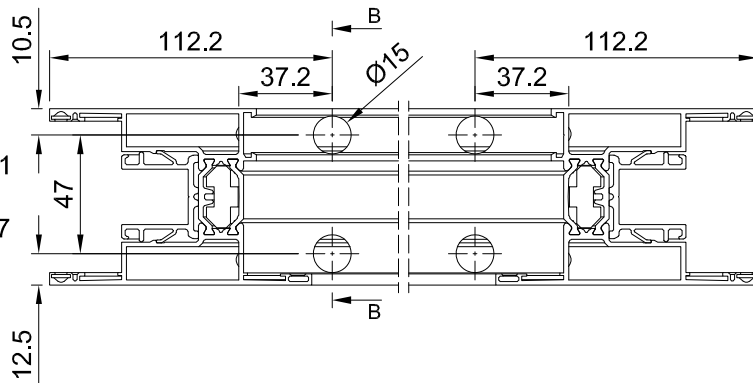
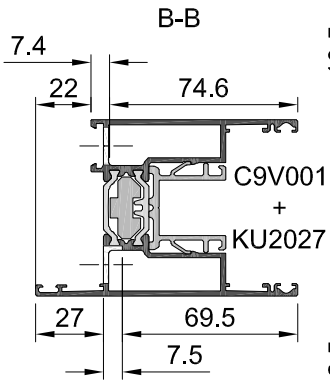
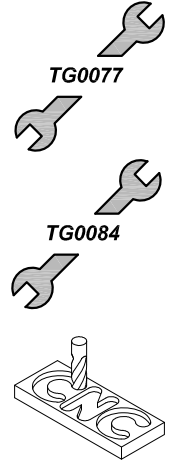
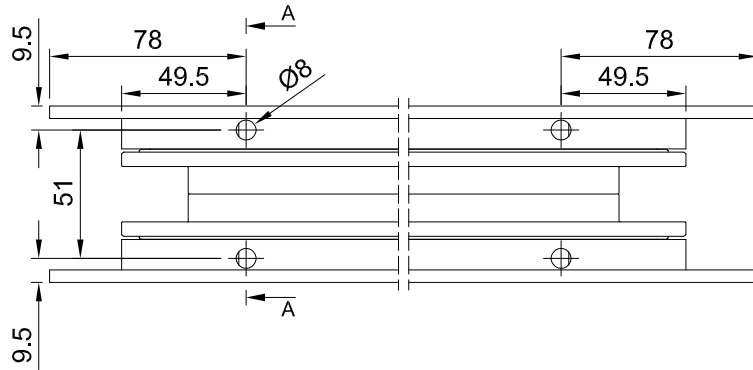
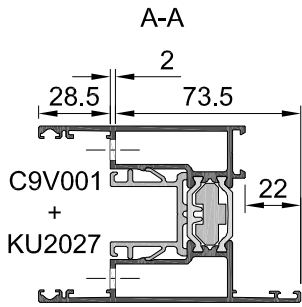
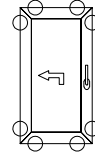
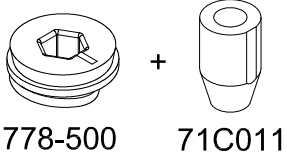

## PREPARAZIONE ANTE

### LAVORAZIONE SQUADRETTE PROFILATI ANTE

2 / 2

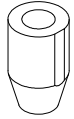

71C011



J.6.22

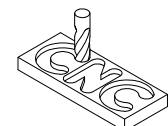
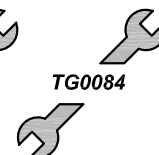
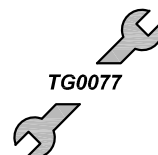
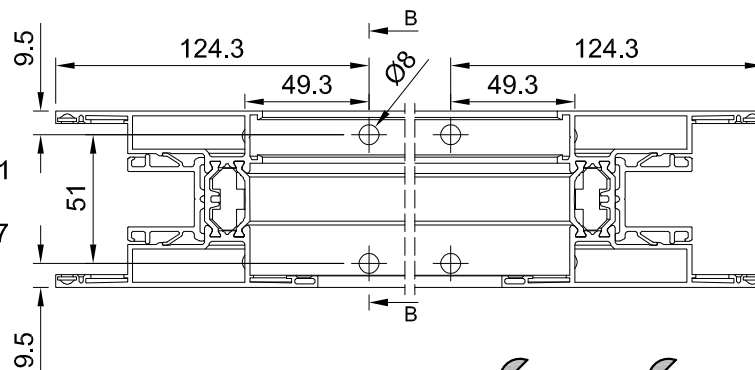
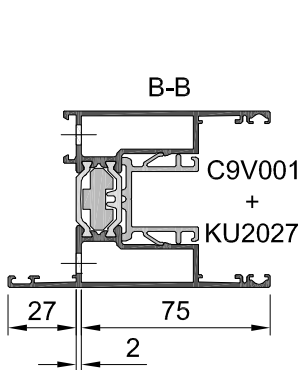
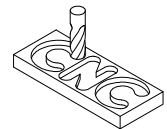
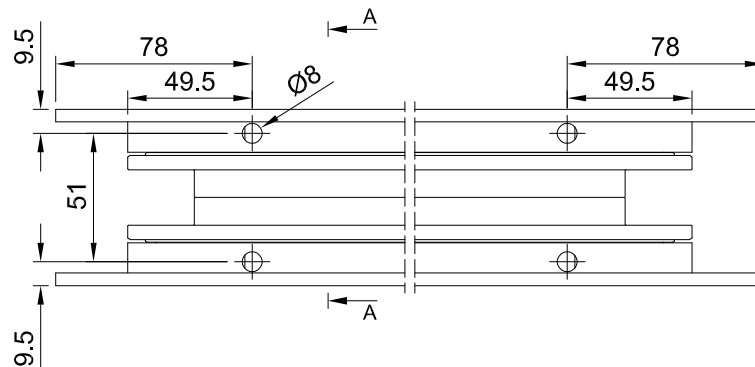
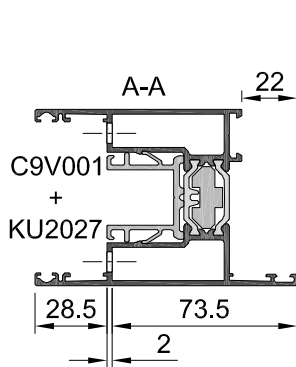
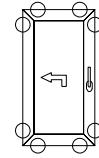

**LAVORAZIONE DEL C9V051 PROFILATO ANTA EFFETTO 'BI-METAL'**

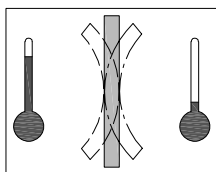

C9V051

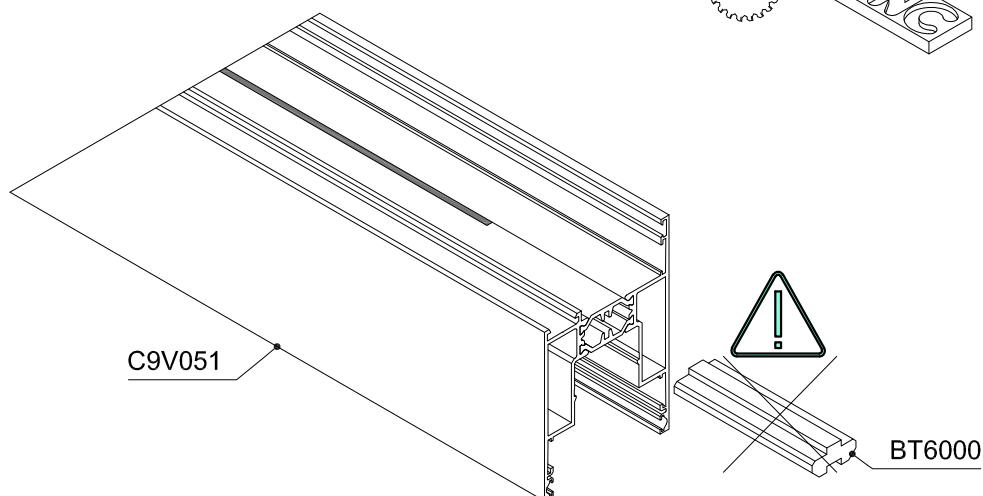
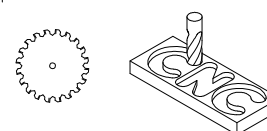
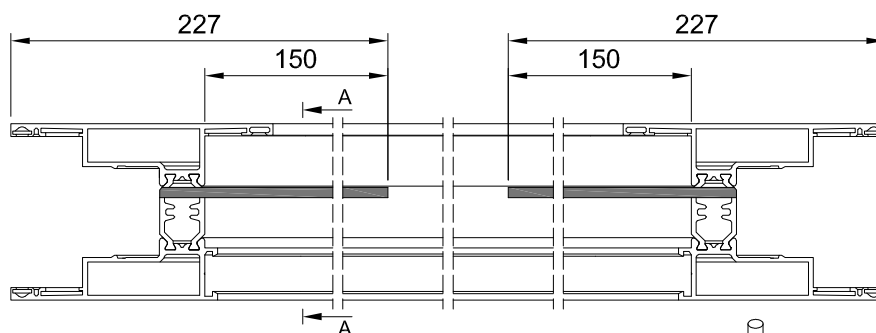
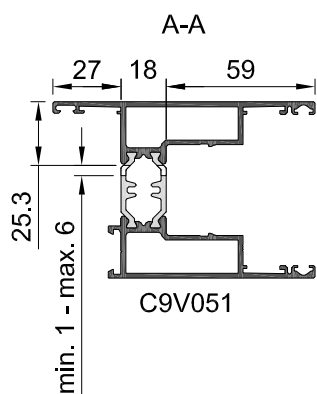
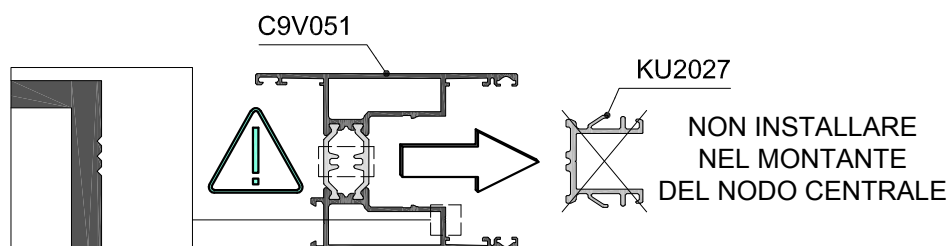
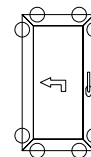

LAVORAZIONE DEL C9V051 PROFILATO ANTA EFFETTO 'BI-METAL'

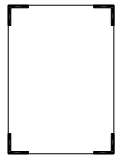
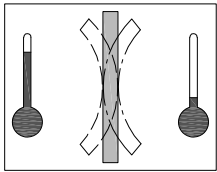

C9V051

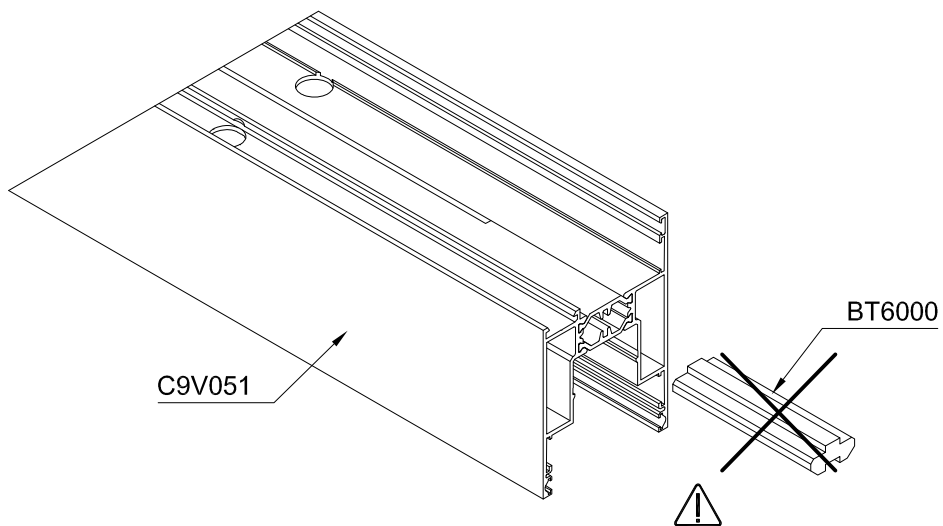
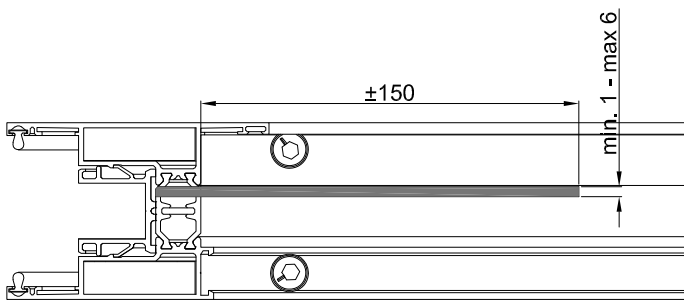
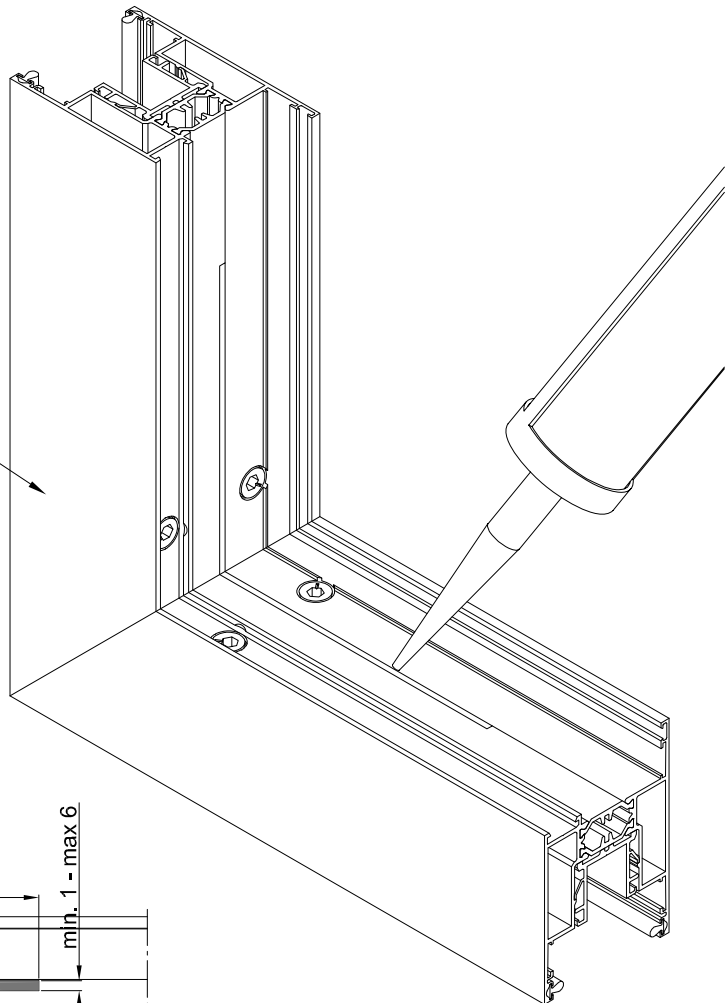

C9V051

BT6000



IMPIEGO DEL C9V051 PROFILATO ANTA EFFETTO 'BI-METAL'

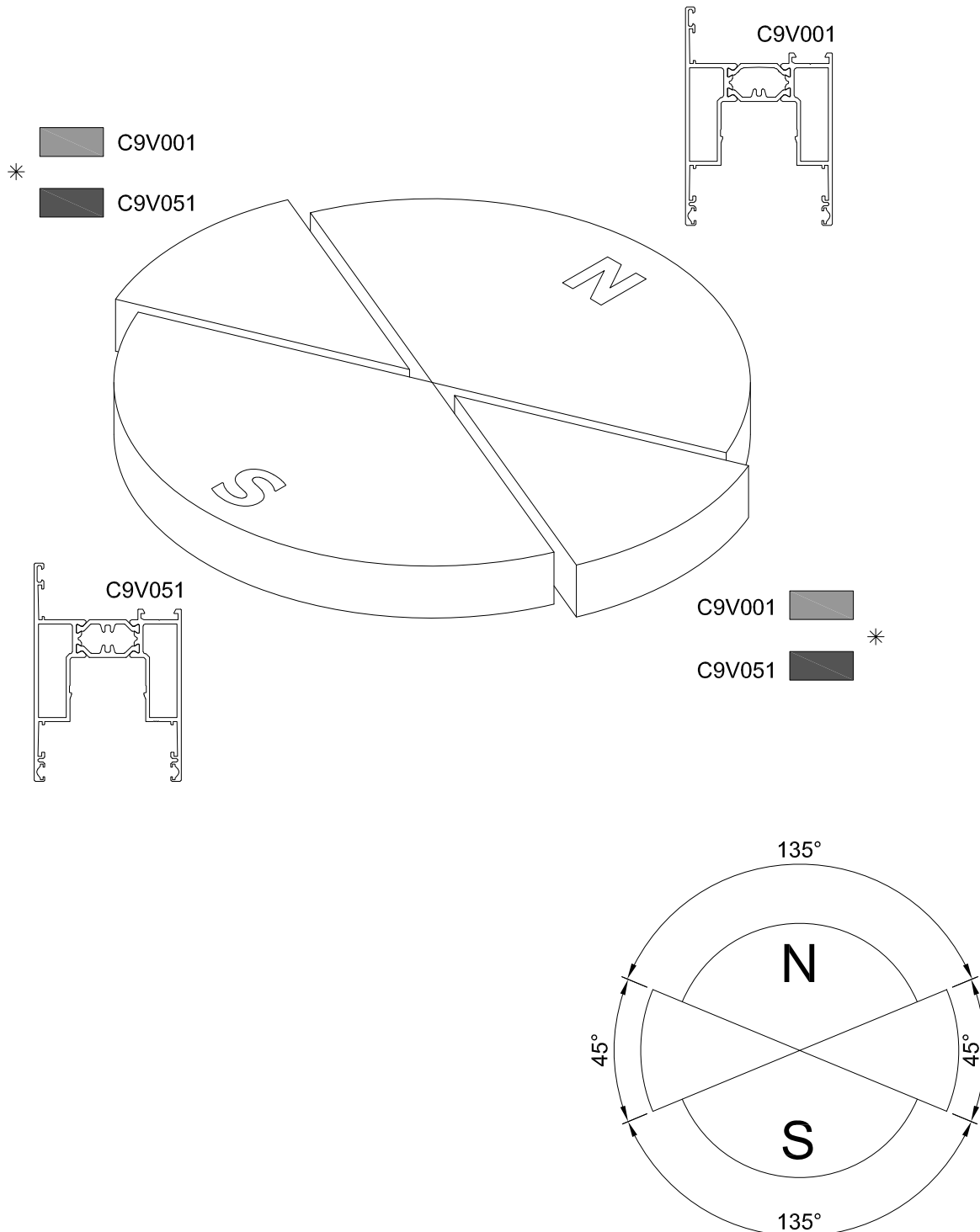

•NOTA:

\* C9V001: colori chiari, C9V051: colori scuri  
 assemblaggio C9V051: J.4.6, stability C9V051: K.1.2.

## PREPARAZIONE ANTE

### LAVORAZIONE DRENAGGIO PROFILATA ANTA

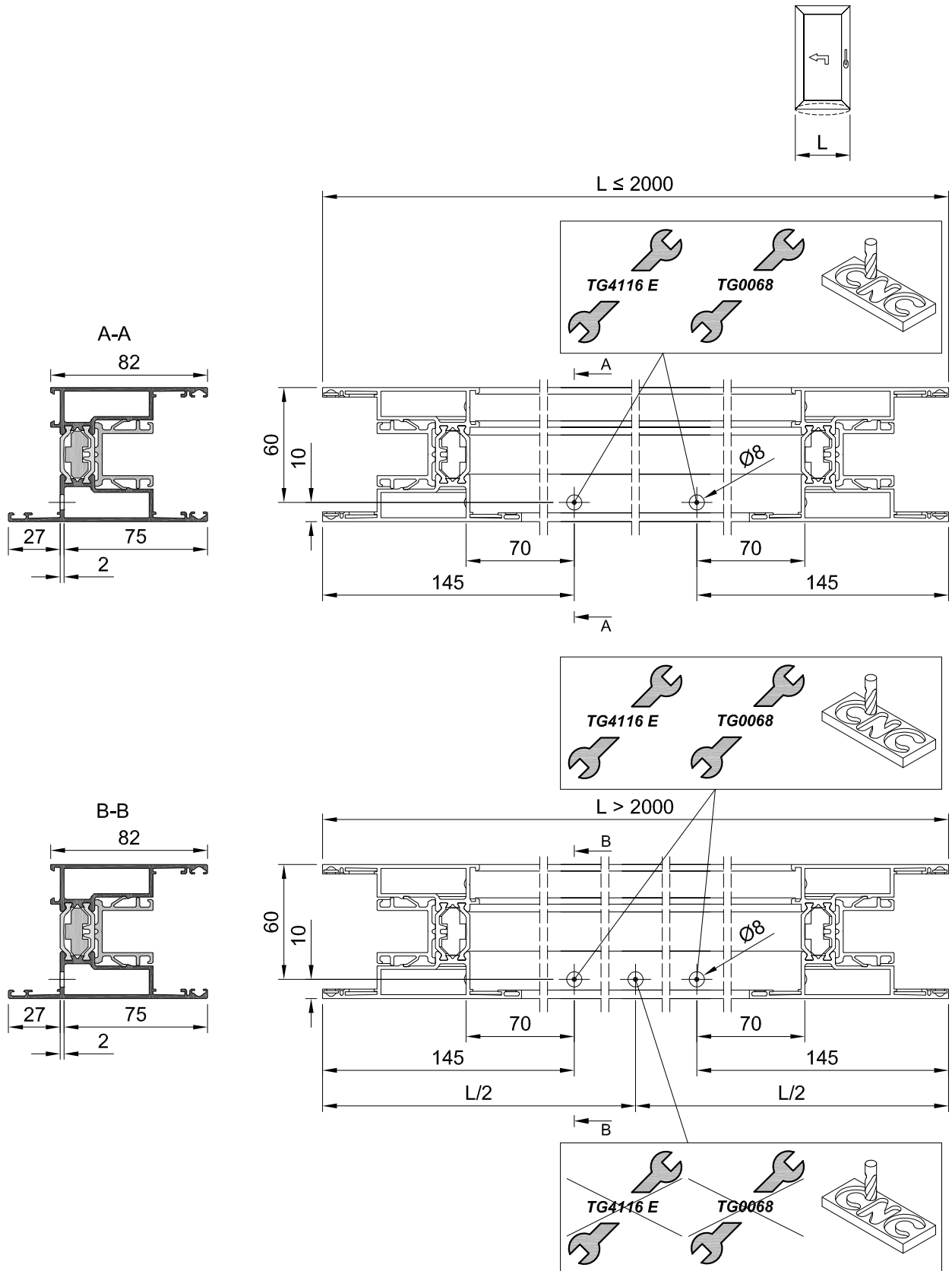

**PANORAMICA LAVORAZIONE PARACOLPI SU PROFILATO ANTA**

1 / 2

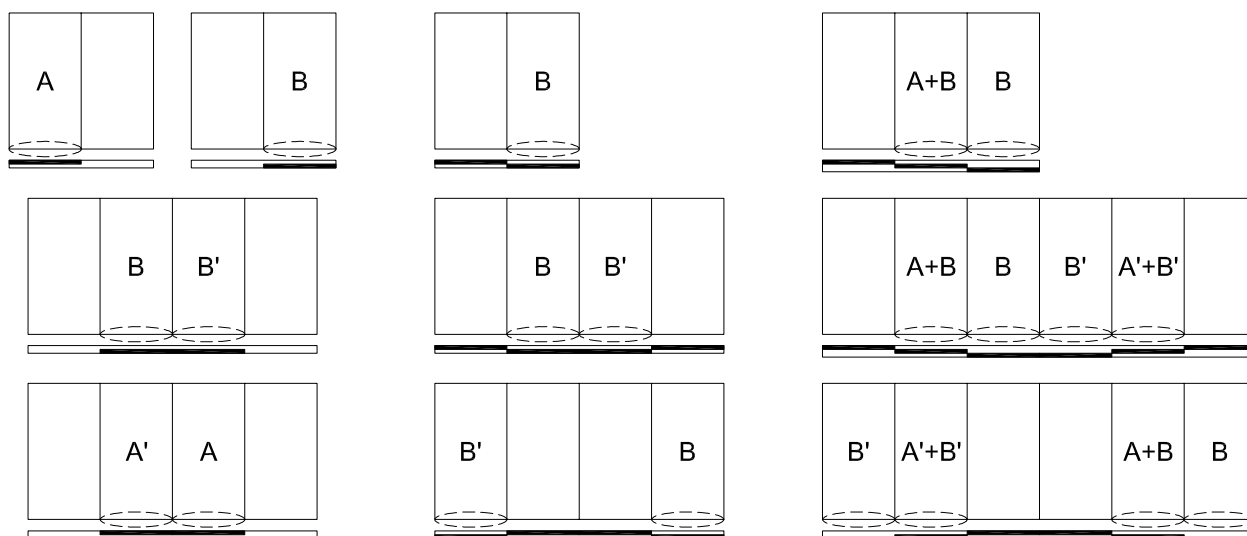
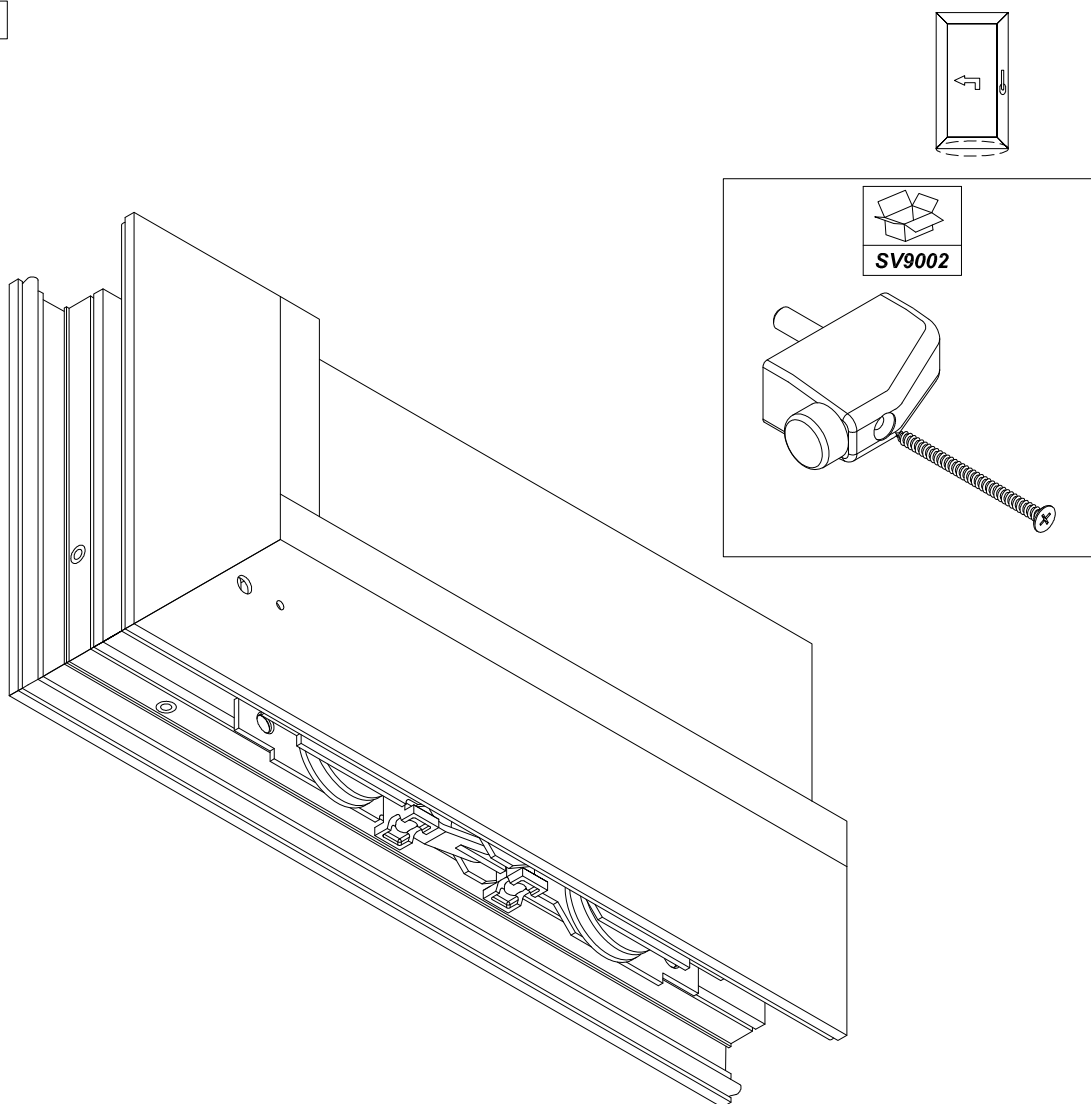

 **C160-ASS-2116L**



### LAVORAZIONE PARACOLPI SU PROFILATO ANTA

2 / 2

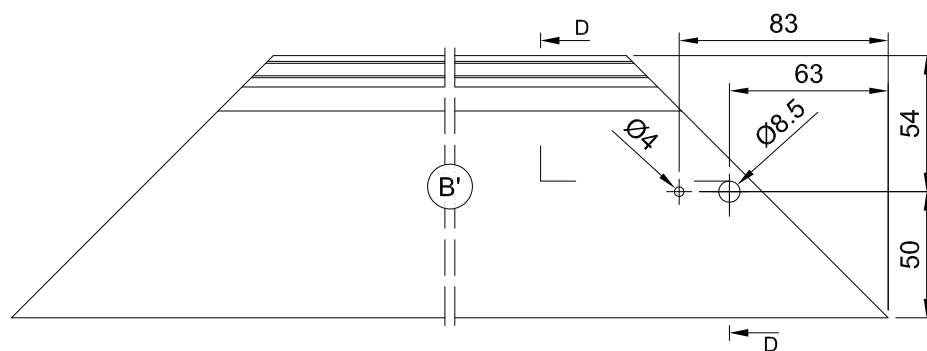
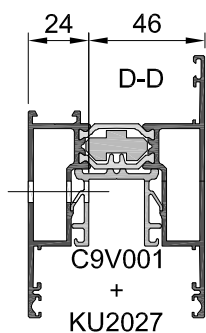
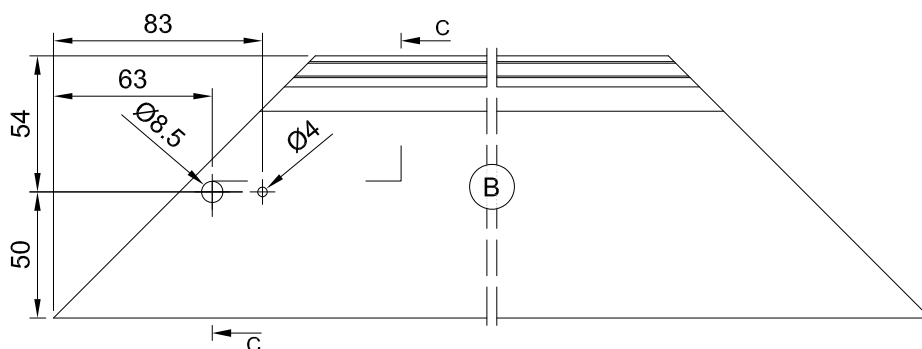
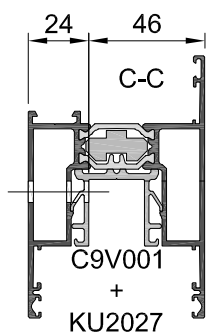
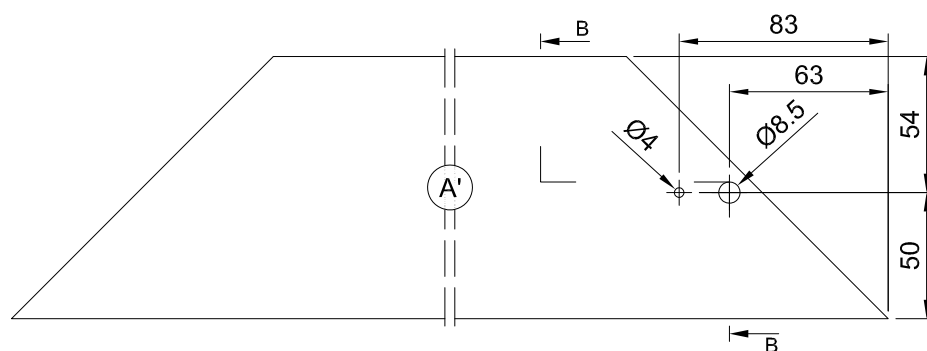
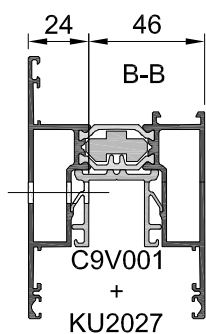
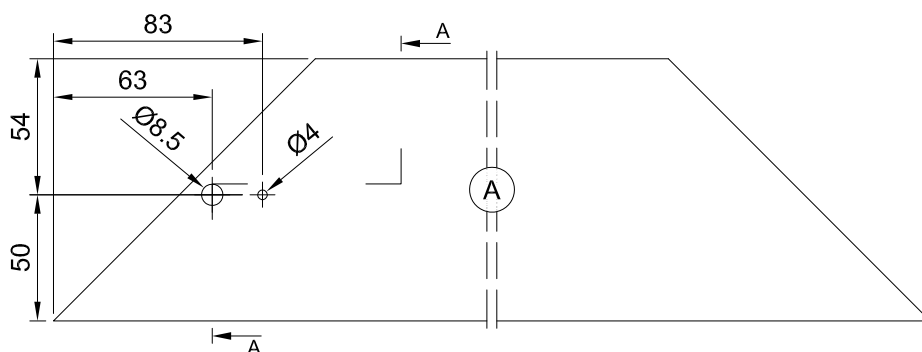
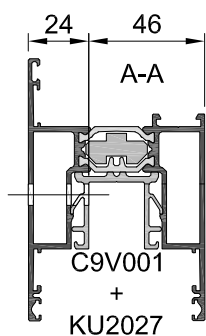
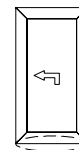

LAVORAZIONE PROFILATO ANTA PER TAPPO 1/2

J.10.3

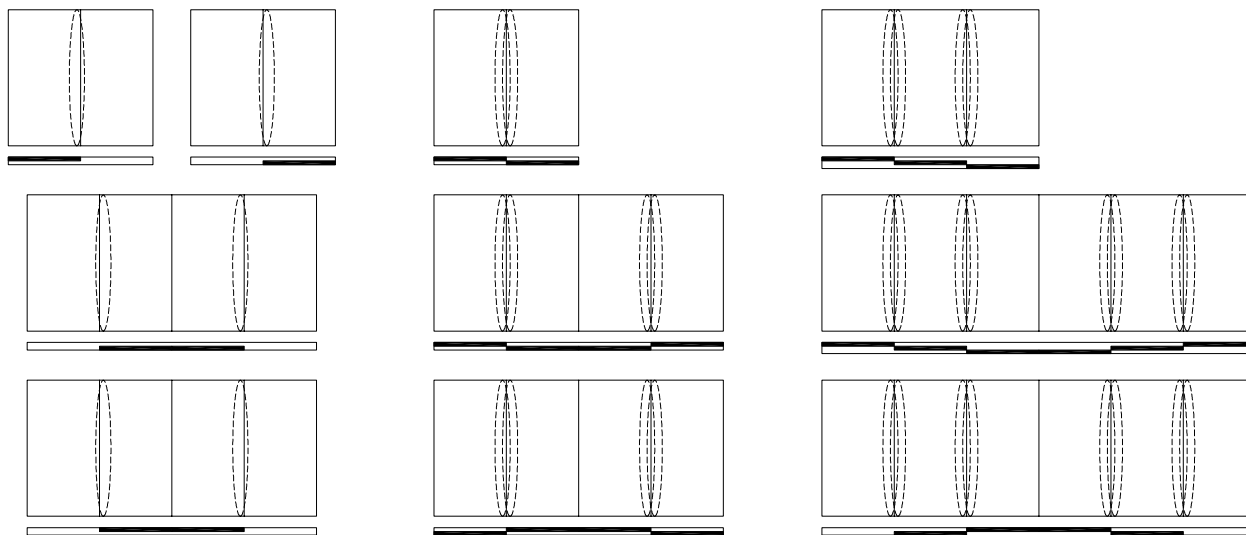
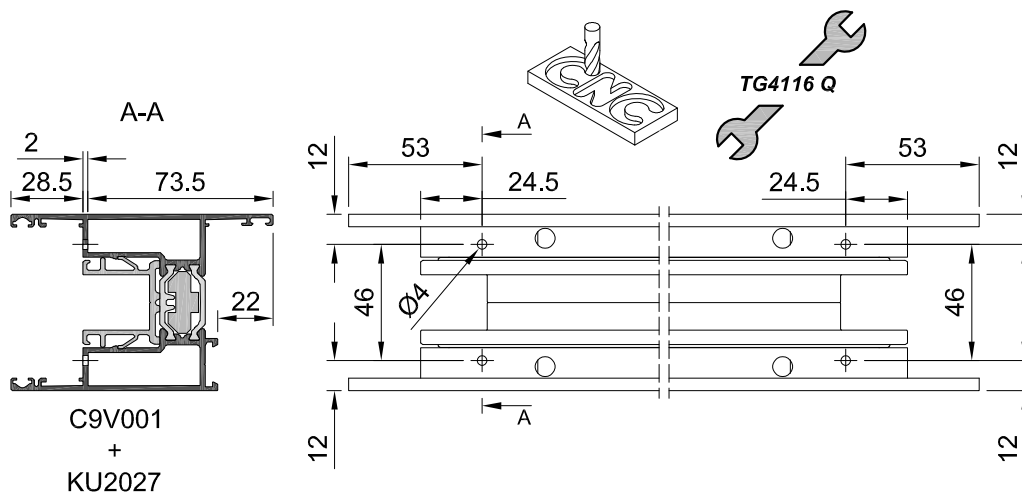
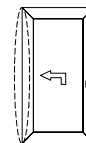

## PREPARAZIONE ANTE

### LAVORAZIONE PROFILATO ANTA PER FERRAMENTA ALZANTE-SCORREVOLE - PANORAMICA

1 / 5

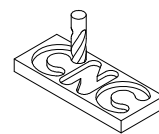
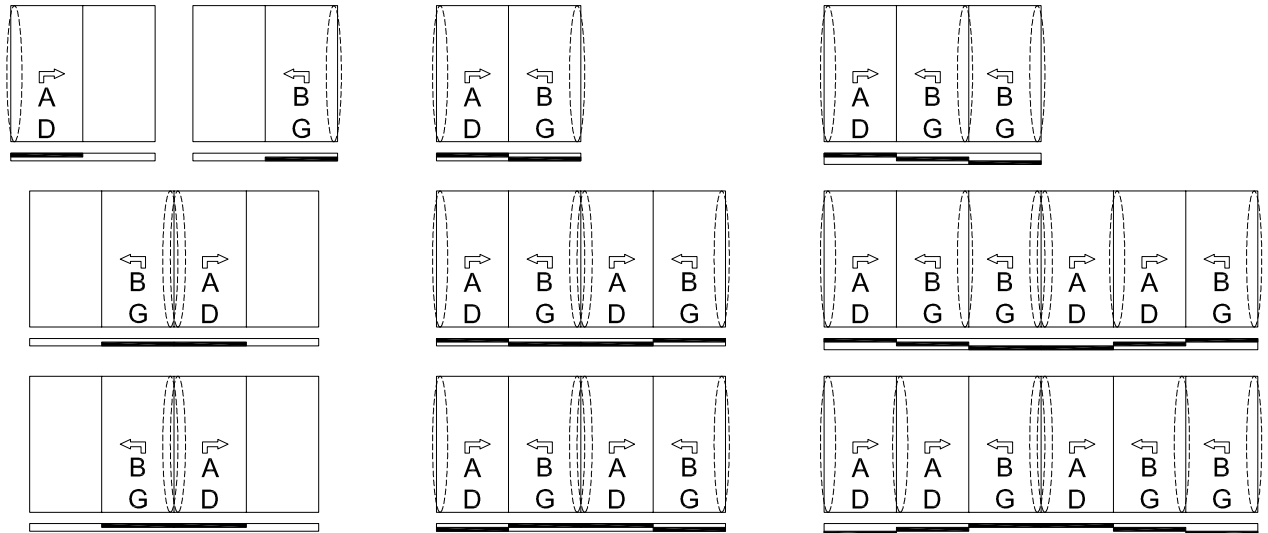
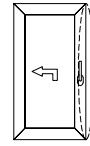

A, B - J.6.15  
D - J.6.16  
G - J.6.17

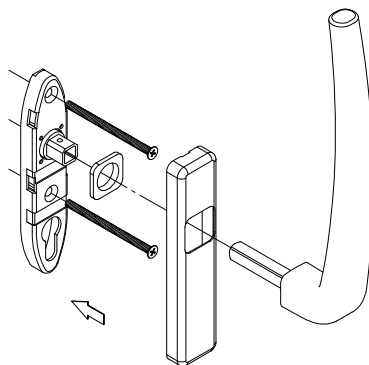

J.7.19  
J.7.24\*

\* - S-LINE

**LAVORAZIONE PROFILATO ANTA PER FERRAMENTA ALZANTE-SCORREVOLE - PANORAMICA**

2 / 5

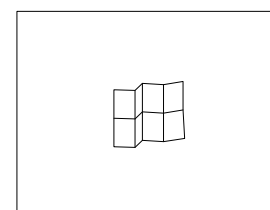
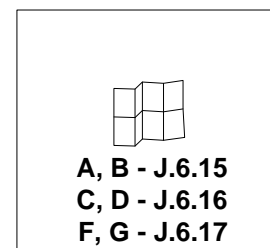
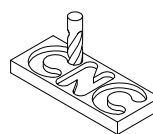
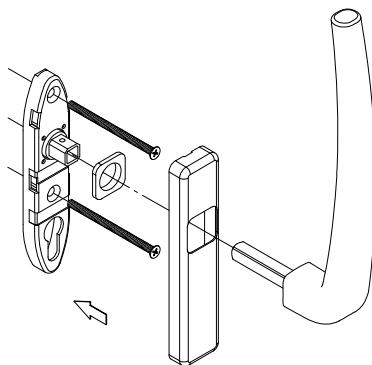
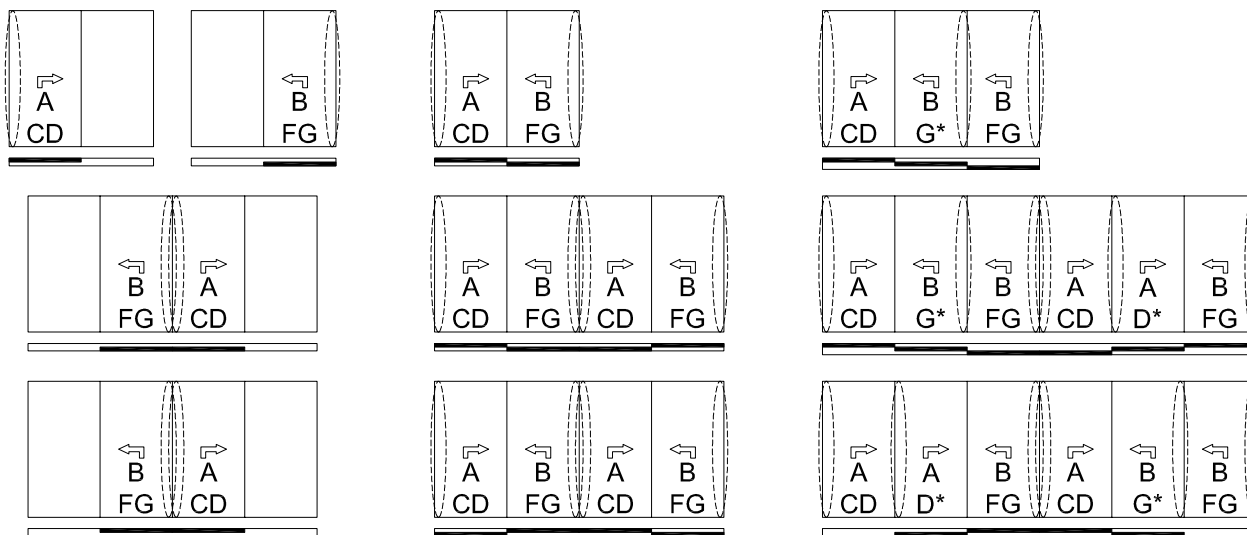
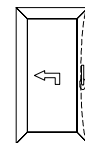

J.7.20

\* - S-LINE

## PREPARAZIONE ANTE

### LAVORAZIONE PROFILATO ANTA PER FERRAMENTA ALZANTE-SCORREVOLE - PANORAMICA

3 / 5

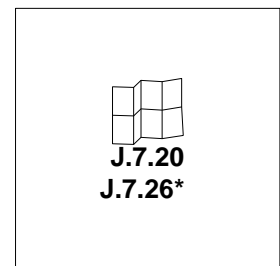
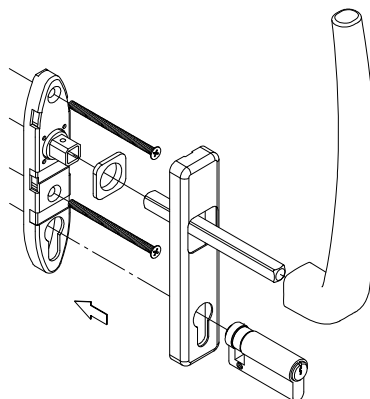
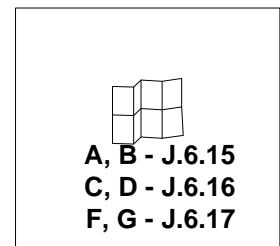
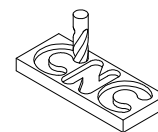
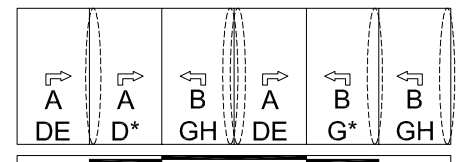
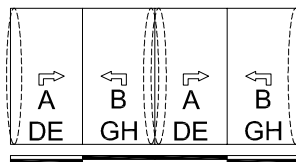
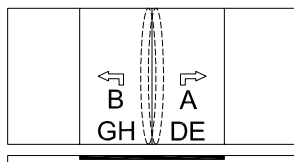
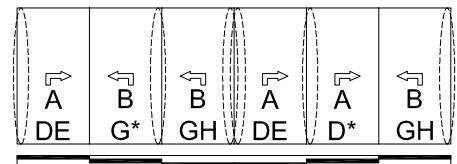
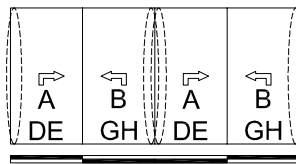
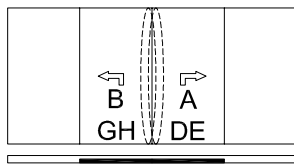
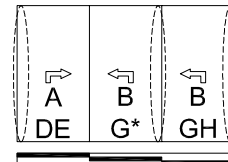
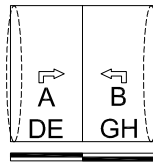
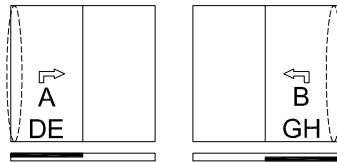
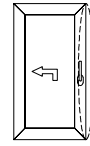

\* - S-LINE

**LAVORAZIONE PROFILATO ANTA PER FERRAMENTA ALZANTE-SCORREVOLE - PANORAMICA**

4 / 5

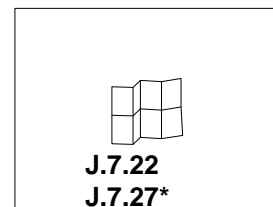
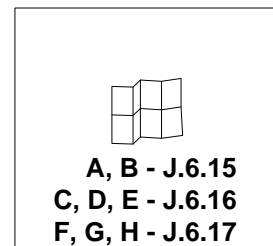
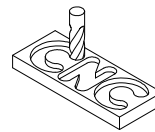
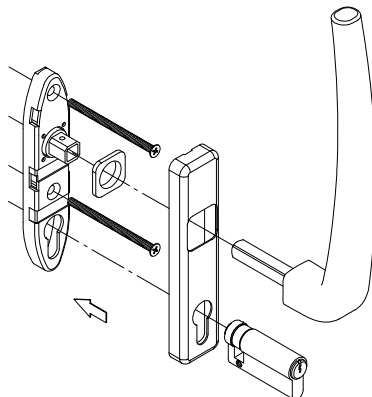
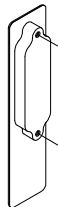
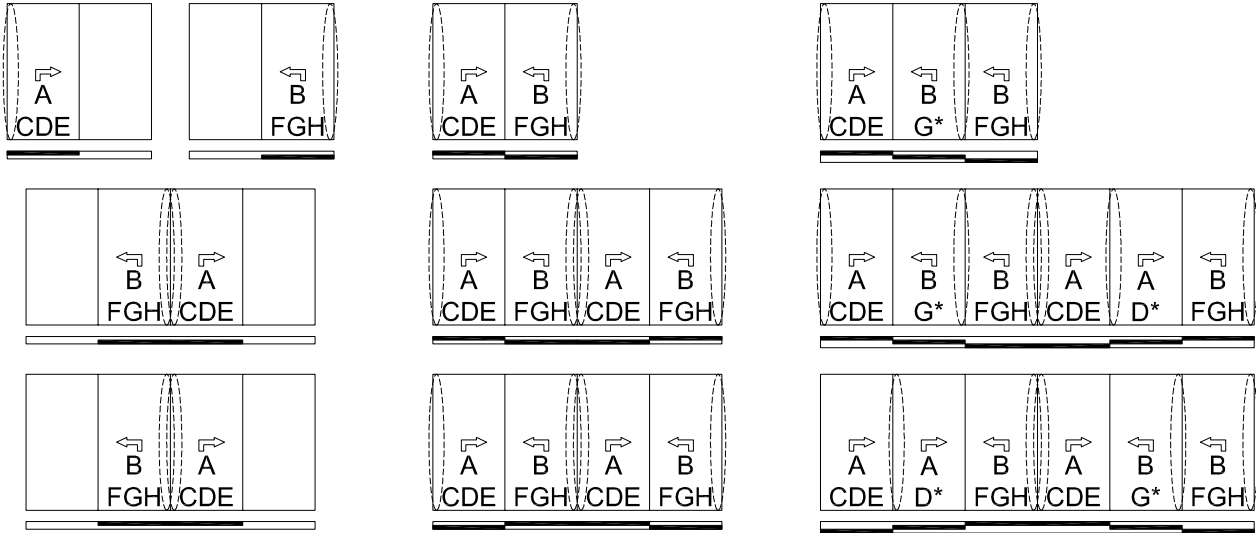
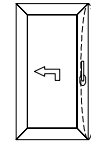

\* - S-LINE

## PREPARAZIONE ANTE

### LAVORAZIONE PROFILATO ANTA PER FERRAMENTA ALZANTE-SCORREVOLE - PANORAMICA

5 / 5

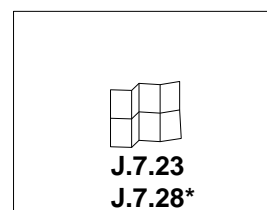
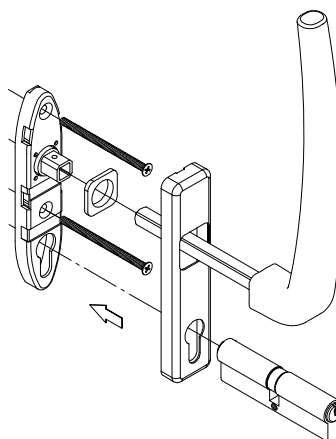
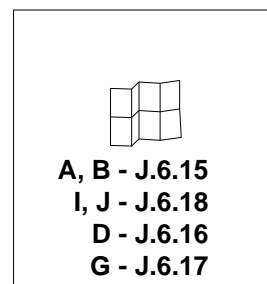
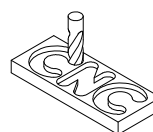
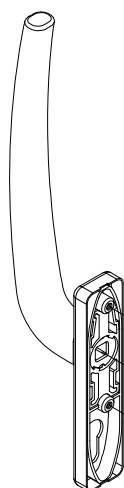
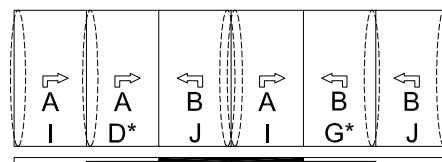
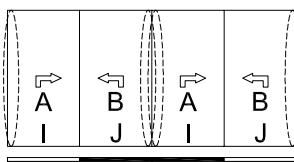
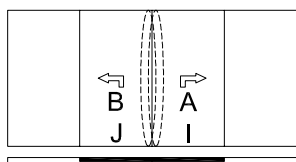
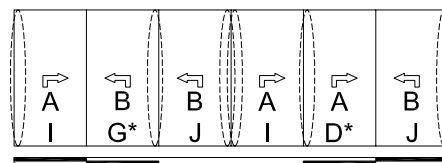
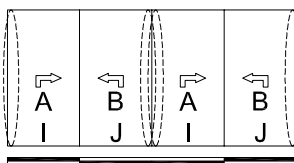
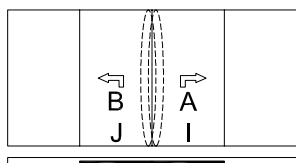
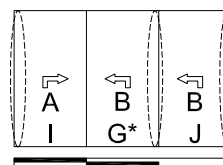
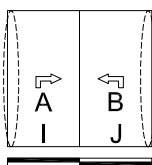
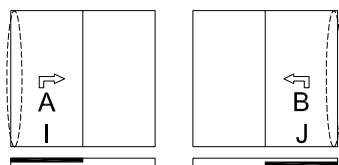
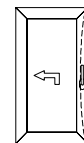

\* - S-LINE

**LAVORAZIONE PROFILATO ANTA PER FERRAMENTA ALZANTE-SCORREVOLE**

1 / 4

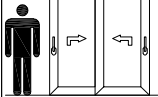
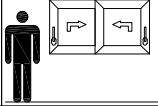
Hh	Hv	
1003	1904 - 3403	
403	1303 - 1903	

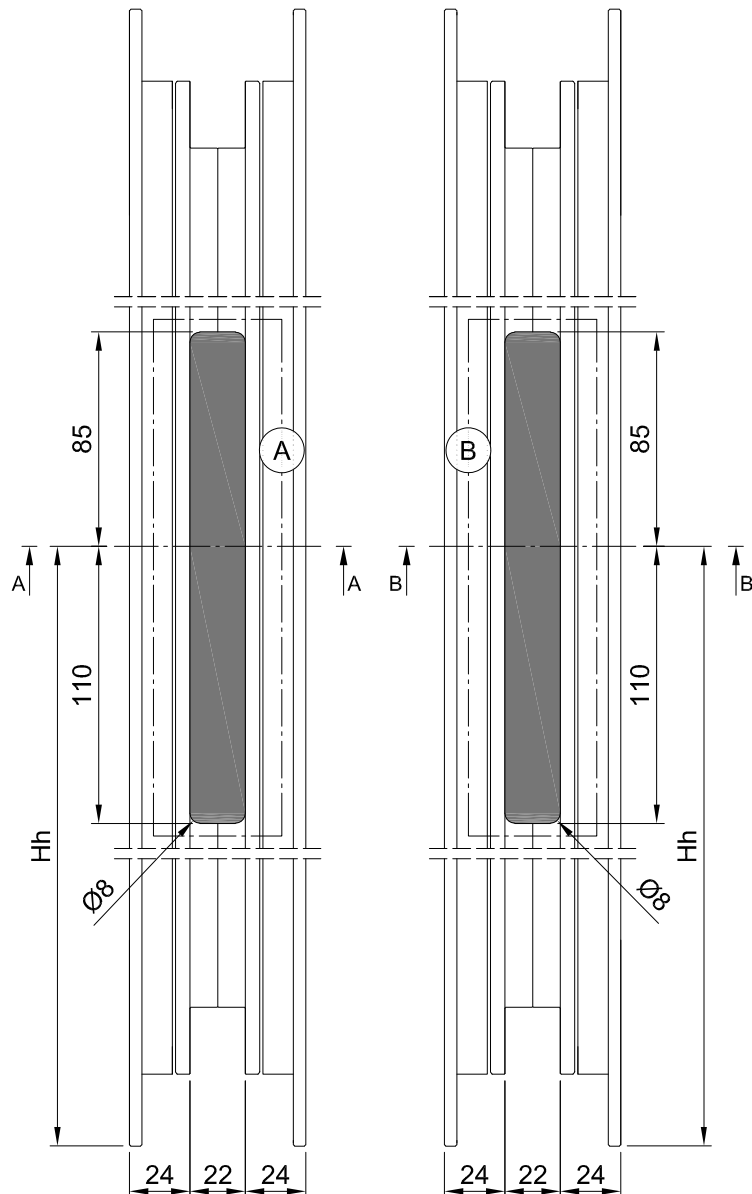
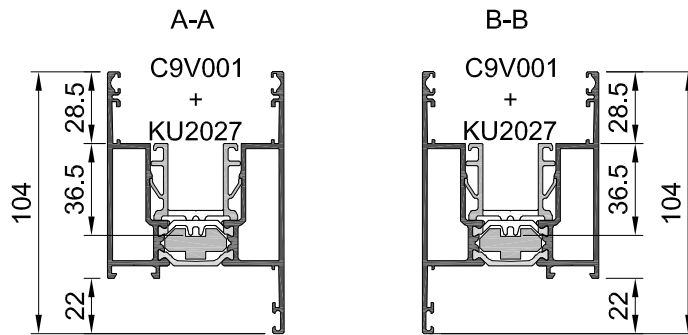
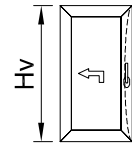

 **C160-ASS-2123L**



### LAVORAZIONE PROFILATO ANTA PER FERRAMENTA ALZANTE-SCORREVOLE

2 / 4

Hh	Hv	
1003	1904 - 3403	
403	1303 - 1903	

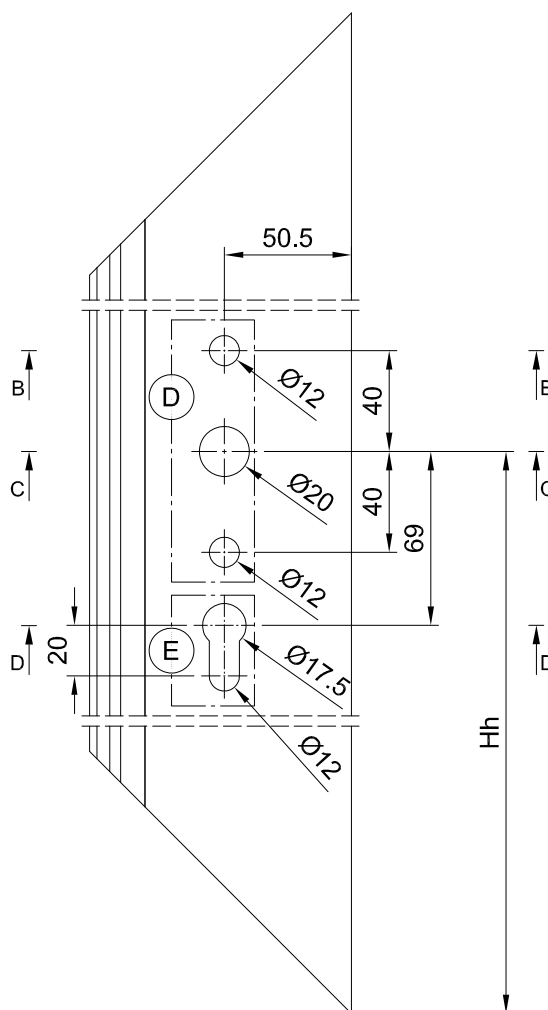
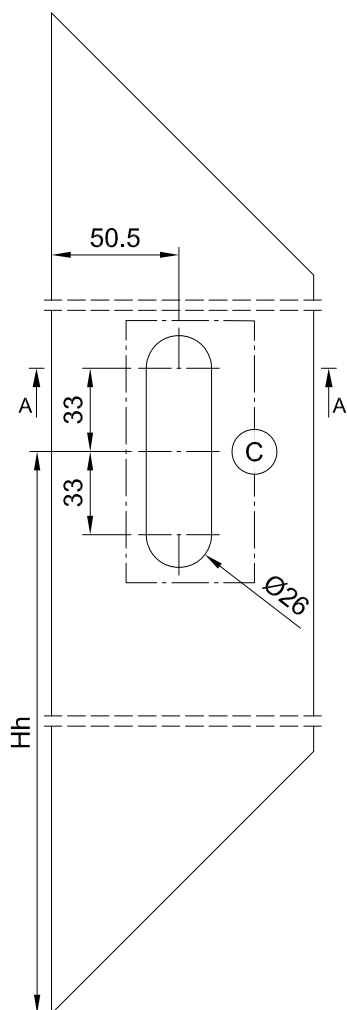
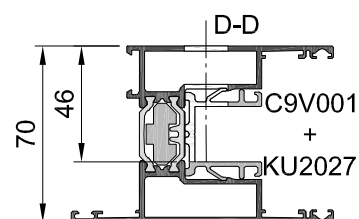
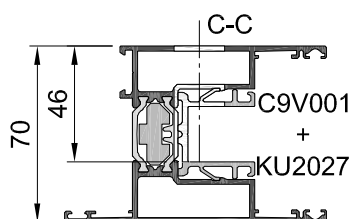
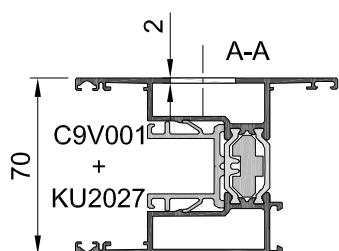
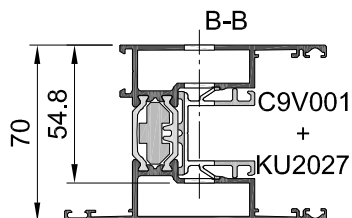
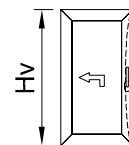

**LAVORAZIONE PROFILATO ANTA PER FERRAMENTA ALZANTE-SCORREVOLE**

3 / 4

Hh	Hv	
1003	1904 - 3403	
403	1303 - 1903	

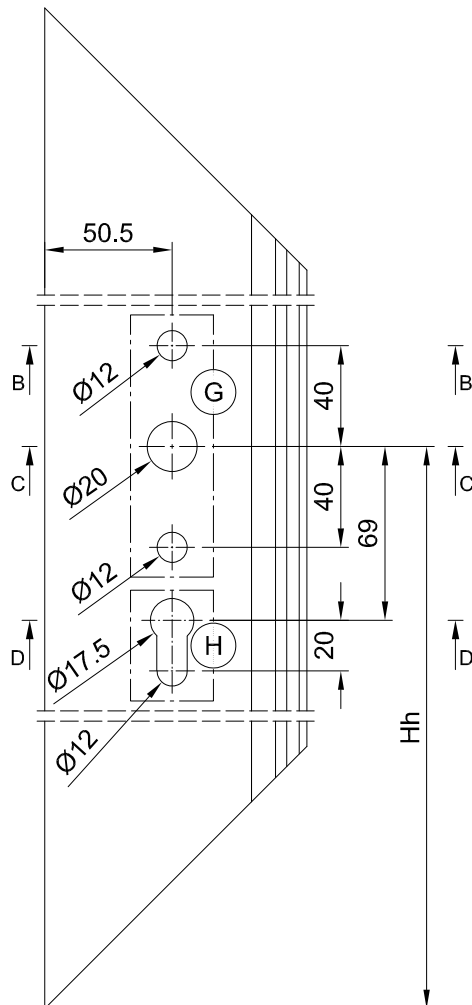
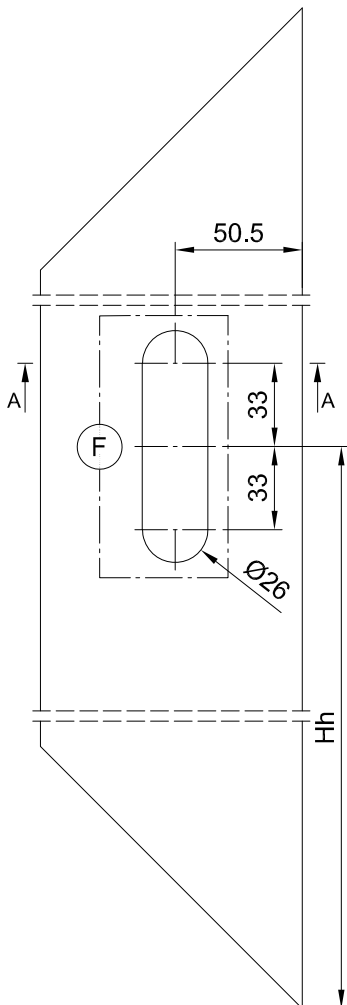
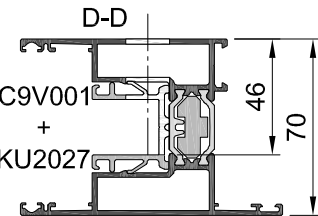
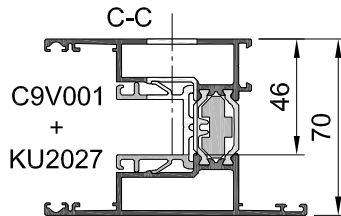
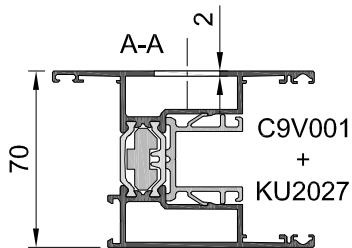
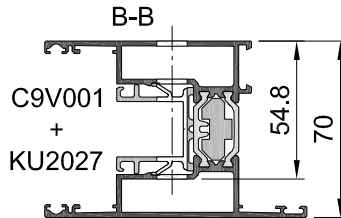
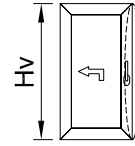

**C160-ASS-2125L**

### LAVORAZIONE PROFILATO ANTA PER FERRAMENTA ALZANTE-SCORREVOLE

4 / 4

Hh	Hv	
1003	1904 - 3403	
403	1303 - 1903	



J.6.13

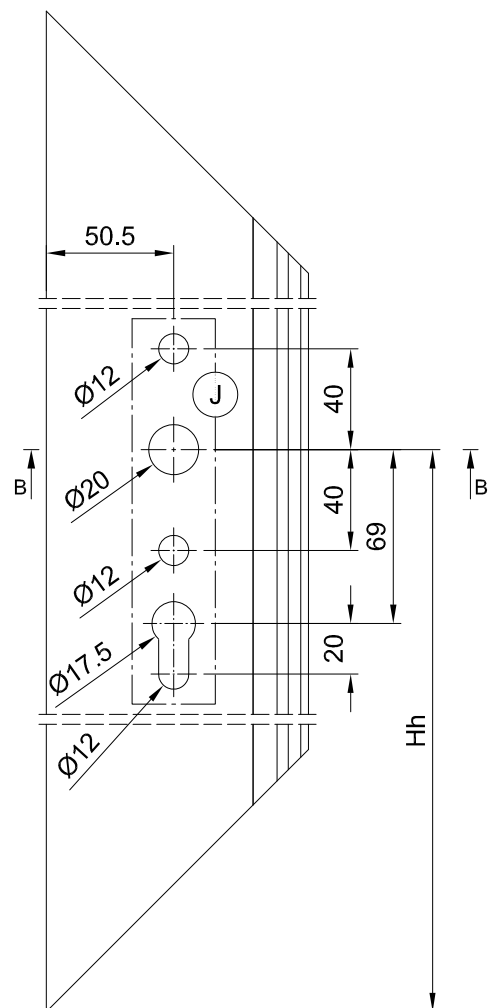
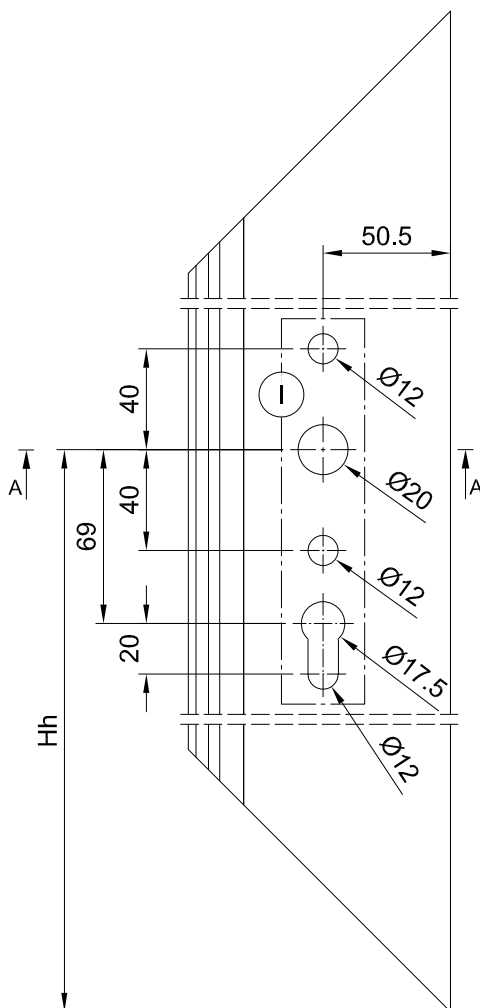
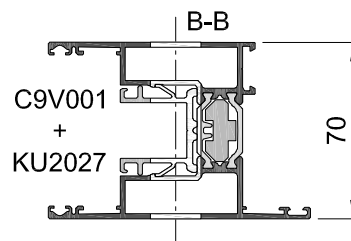
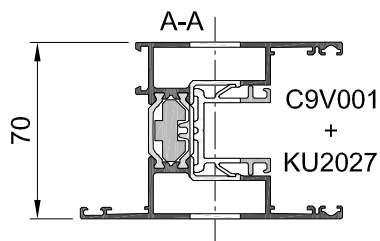
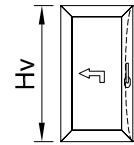



## PREPARAZIONE ANTE

### INSTALLAZIONE GUARNIZIONE RU0099 PER ALZANTE-SCORREVOLE - 3-BINARI

2 / 2

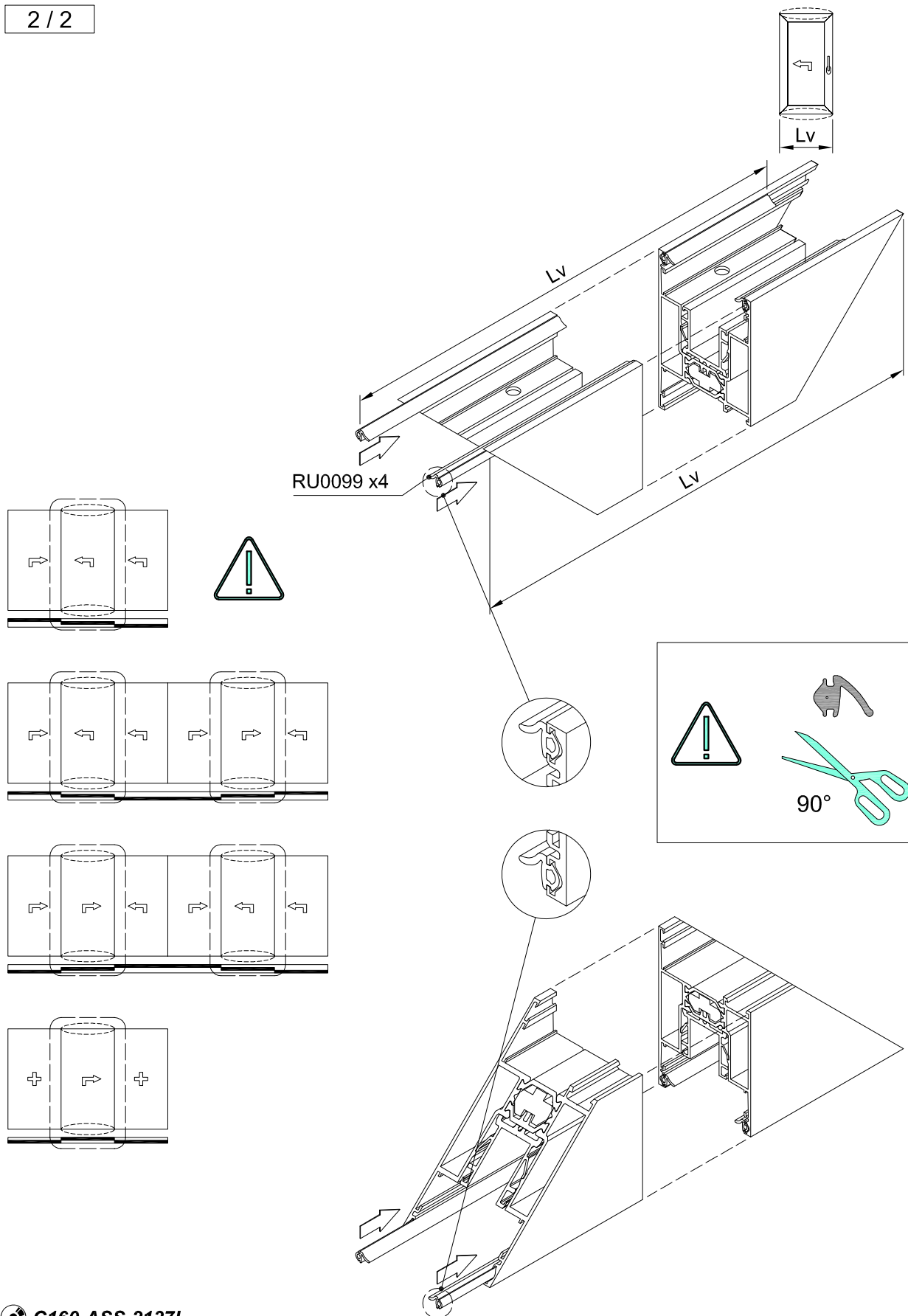



## PREPARAZIONE ANTE

### ASSEMBLAGGIO PROFILATO ANTA CON SQUADRETTE

2 / 3

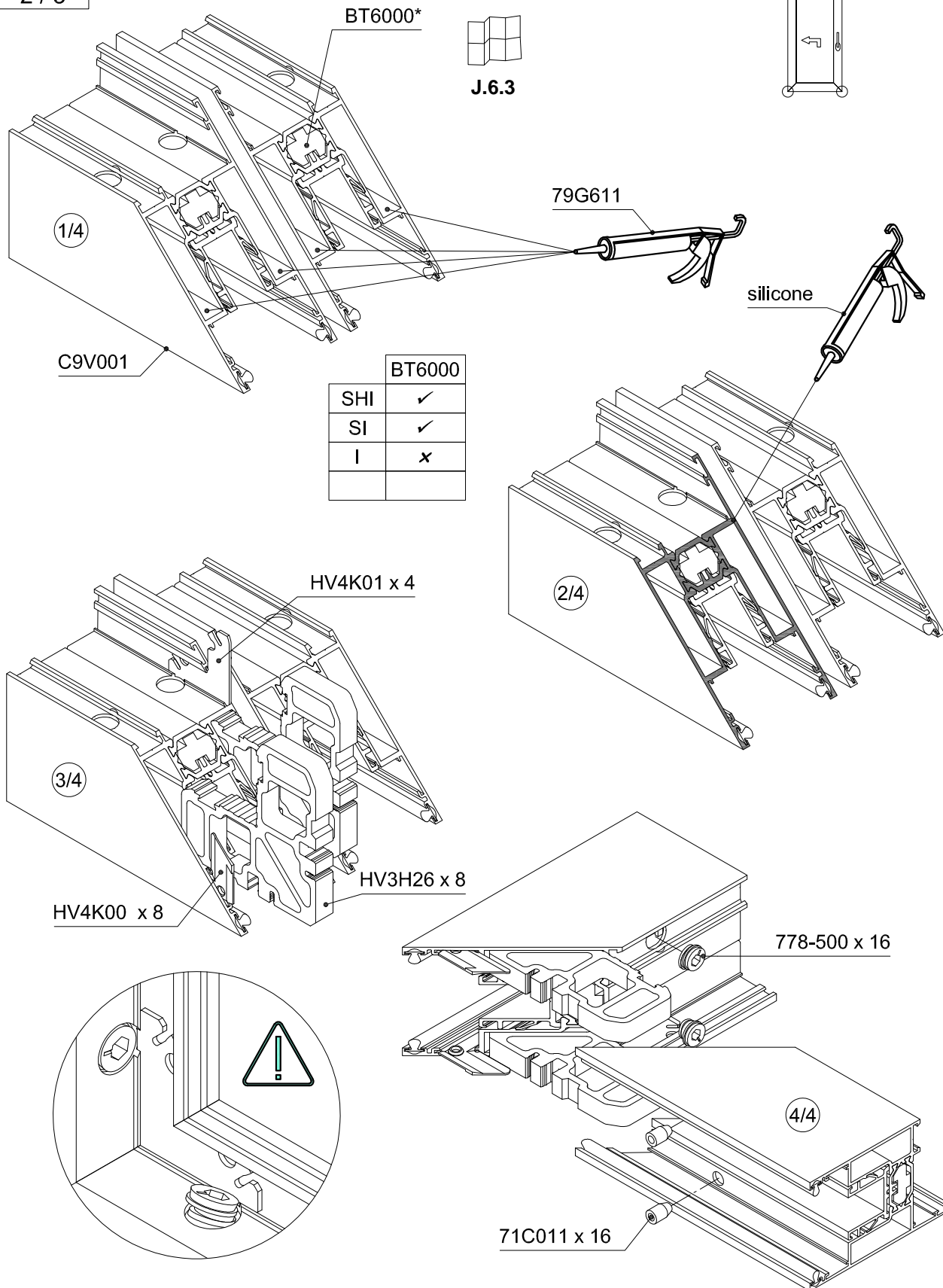

C160-ASS-2140L

**ASSEMBLAGGIO PROFILATO ANTA CON SQUADRETTE**

3 / 3

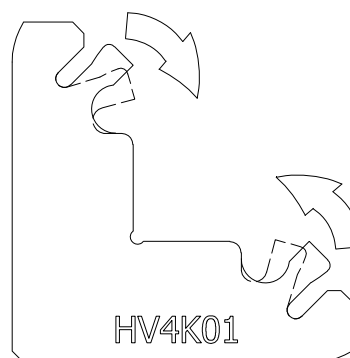
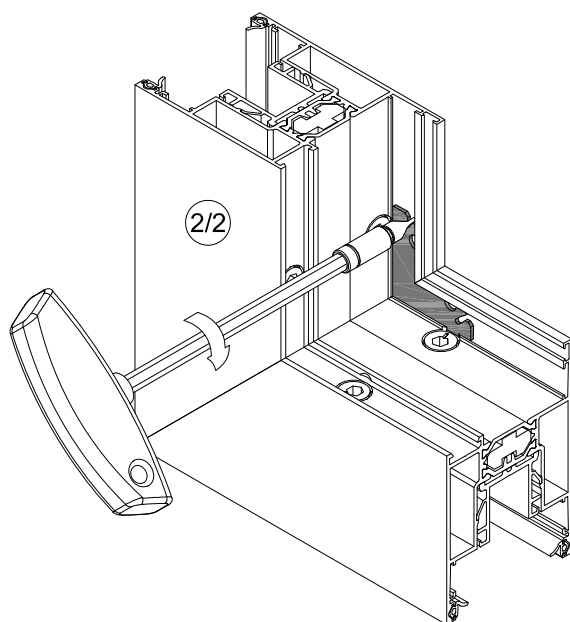
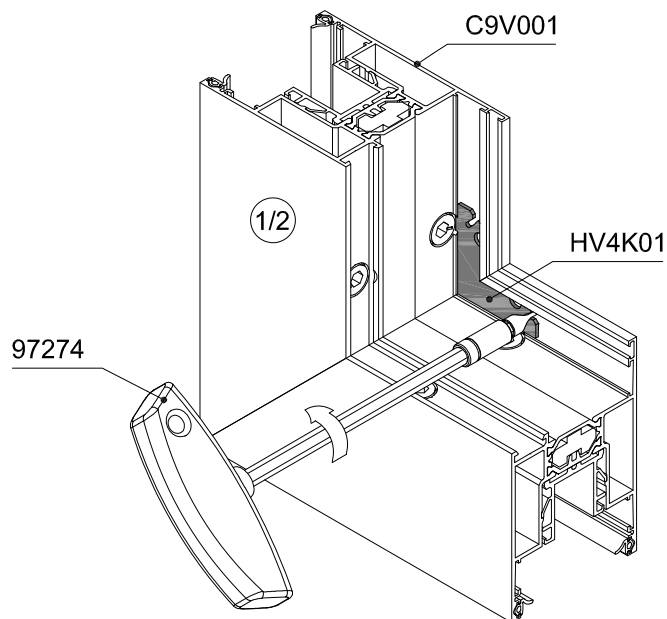
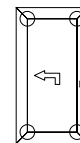



### CONTENUTO

Assemblaggio ferramenta anta.....	J.8.1
Contenuto.....	J.8.1
Ferramenta alzante-scorrevole - panoramica.....	J.8.2
Preparazione carrelli alzante-scorrevole.....	J.8.3
Preparazione carrelli alzante-scorrevole (300 - 400 kg).....	J.8.5
Preparazione ZB0033/ZB0034/ZB0035/ZB0036.....	J.8.12
Preparazione ZB0033/ZB0034/ZB0035/ZB0036 - maniglia interna.....	J.8.13
Assemblaggio ZB0053/ZB0054 - sollevamento servo assistito.....	J.8.14
Preparazione ZB0046.....	J.8.15
Assemblaggio ZB0035/ZB0036 con ZB0046.....	J.8.16
Assemblaggio meccanismo chiusura alzante-scorrevole.....	J.8.17
Assemblaggio meccanismo chiusura alzante-scorrevole - anta passiva schema 4 ante.....	J.8.18
Installazione maniglia interna standard alzante-scorrevole.....	J.8.19
Installazione maniglia interna standard e vaschetta esterna alzante-scorrevole.....	J.8.20
Installazione maniglia interna standard con mezzo cilindro alzante-scorrevole.....	J.8.21
Maniglia interna standard con mezzo cilindro e vaschetta alzante-scorrevole.....	J.8.22
Installazione maniglia standard su due lati con cilindro alzante-scorrevole.....	J.8.23
Installazione maniglia interna S-line Harmony alzante-scorrevole.....	J.8.24
Maniglia interna S-line Harmony e vaschetta esterna alzante-scorrevole.....	J.8.25
Installazione maniglia interna S-line Harmony con mezzo cilindro alzante-scorrevole.....	J.8.26
Maniglia interna S-line Harmony con mezzo cilindro e vaschetta alzante-scorrevole.....	J.8.27
Installazione maniglia S-Line Harmony su due lati con cilindro alzante-scorrevole.....	J.8.28

**FERRAMENTA ALZANTE-SCORREVOLE - PANORAMICA**

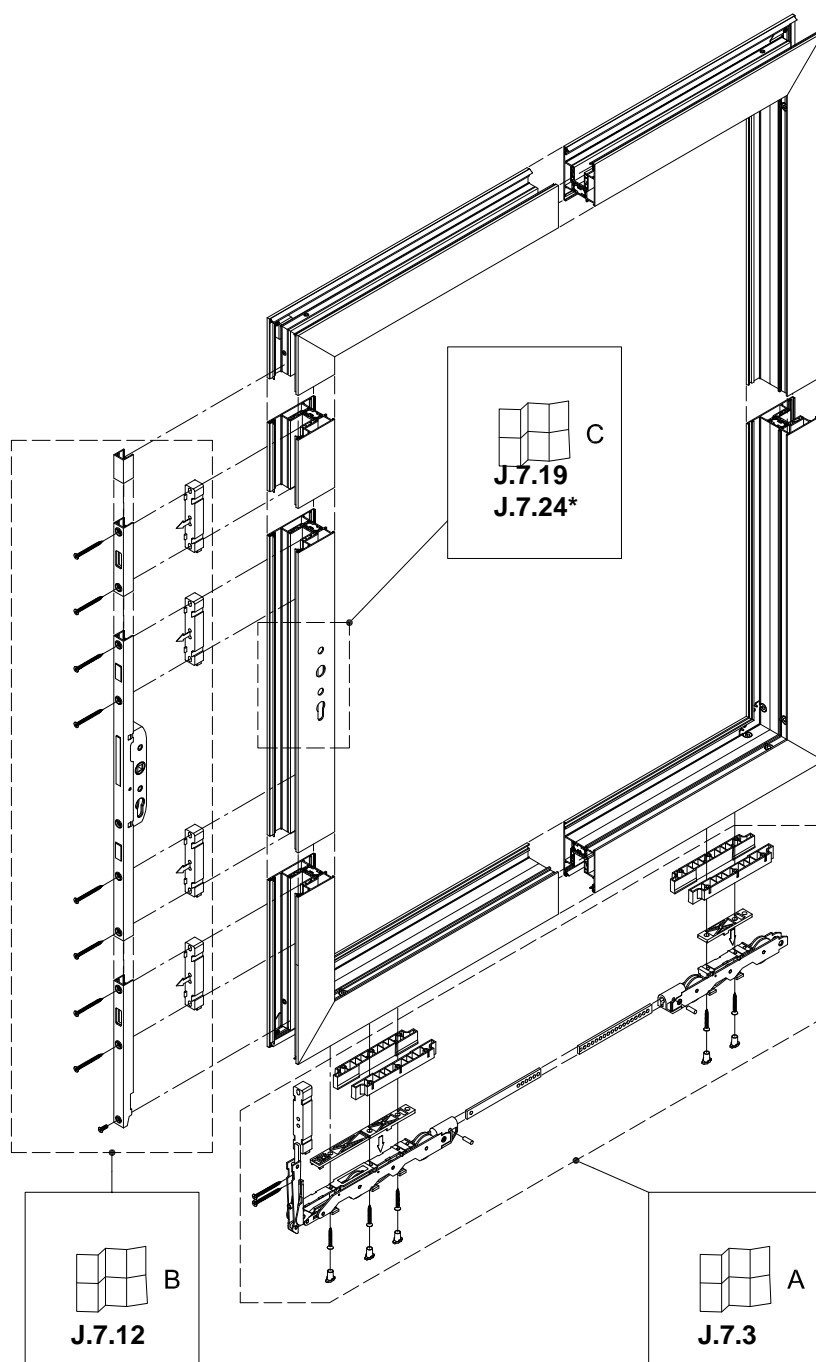
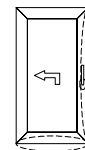

\* - S-LINE

## ASSEMBLAGGIO FERRAMENTA ANTA

### PREPARAZIONE CARRELLI ALZANTE-SCORREVOLE

1 / 9



≤ 300 kg

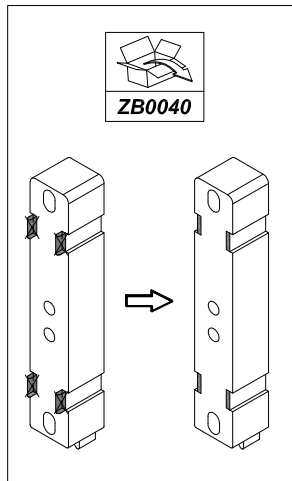
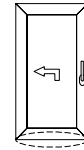

ZB0040

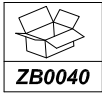
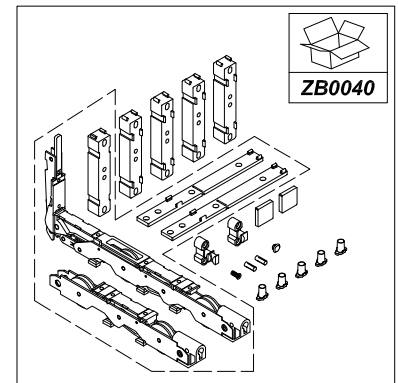

ZB0040

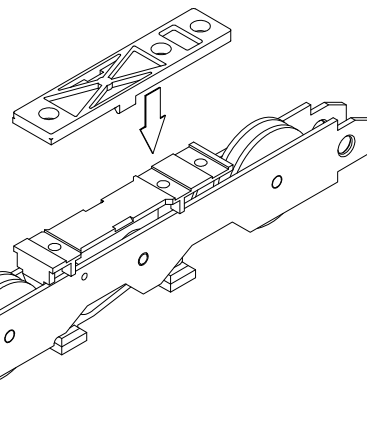
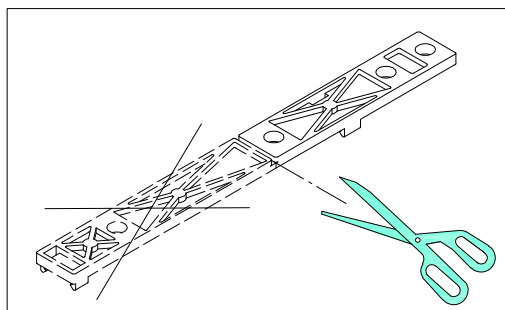
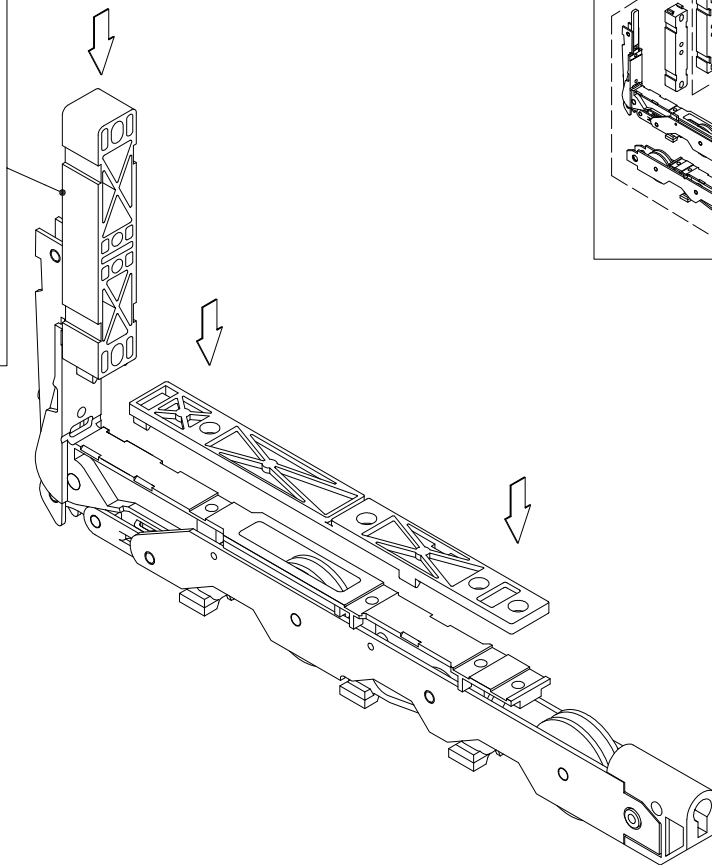

**PREPARAZIONE CARRELLI ALZANTE-SCORREVOLI**

2 / 9

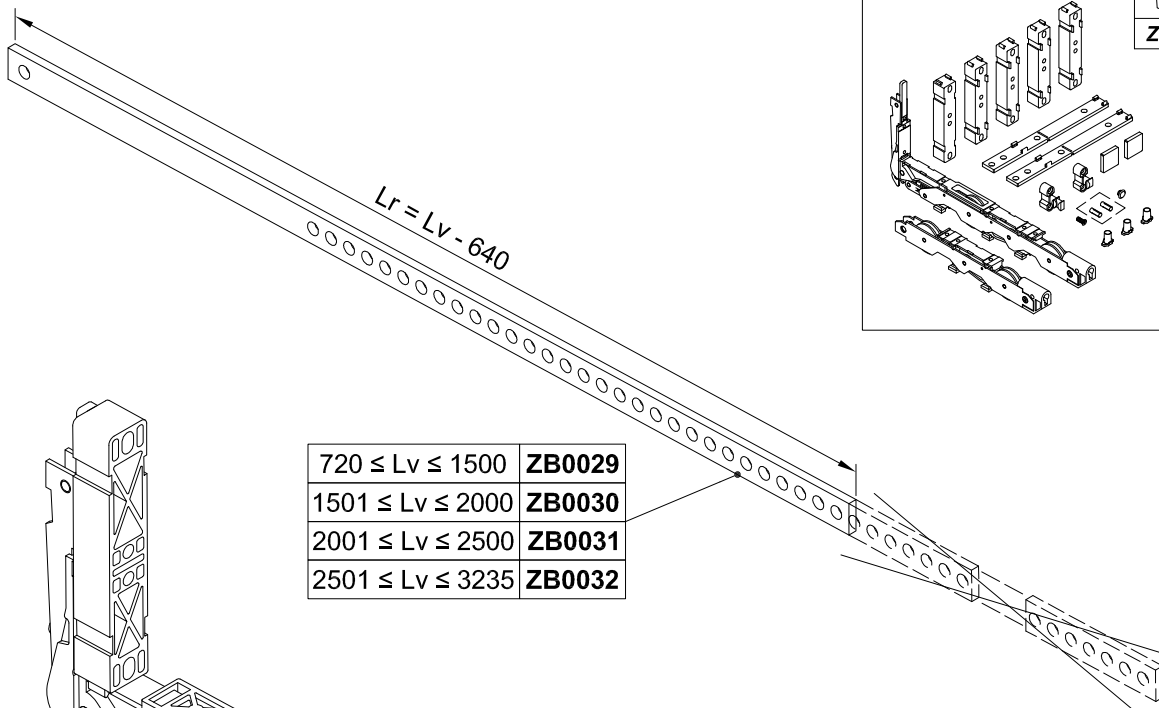
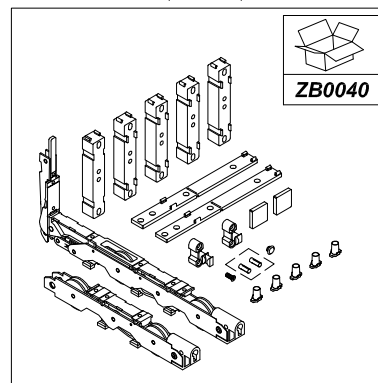
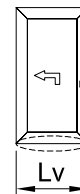

$720 \leq L_v \leq 1500$	<b>ZB0029</b>
$1501 \leq L_v \leq 2000$	<b>ZB0030</b>
$2001 \leq L_v \leq 2500$	<b>ZB0031</b>
$2501 \leq L_v \leq 3235$	<b>ZB0032</b>

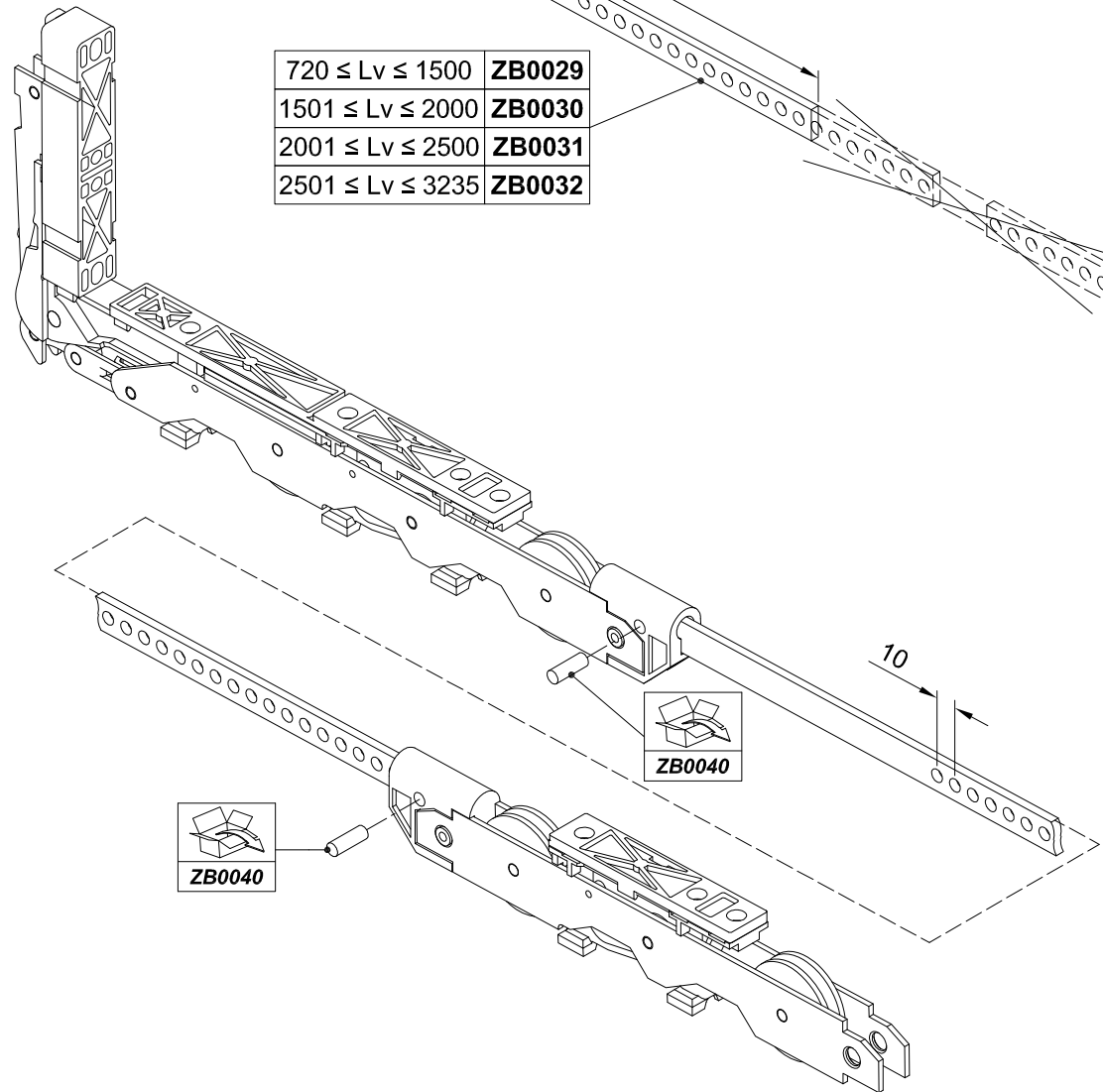

## ASSEMBLAGGIO FERRAMENTA ANTA

### PREPARAZIONE CARRELLI ALZANTE-SCORREVOLE (300 - 400 KG)

3 / 9

300 kg <  ≤ 400 kg

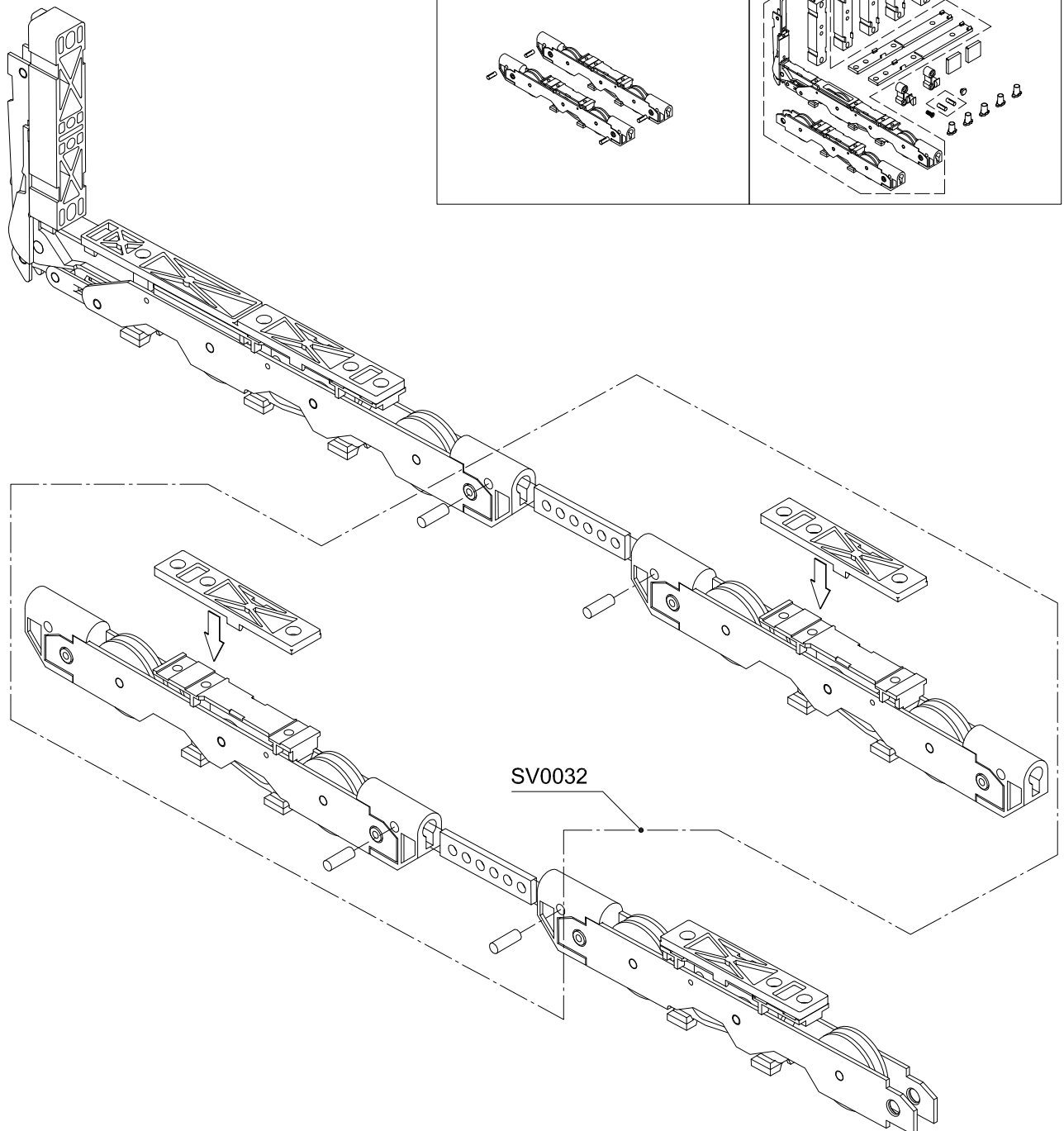
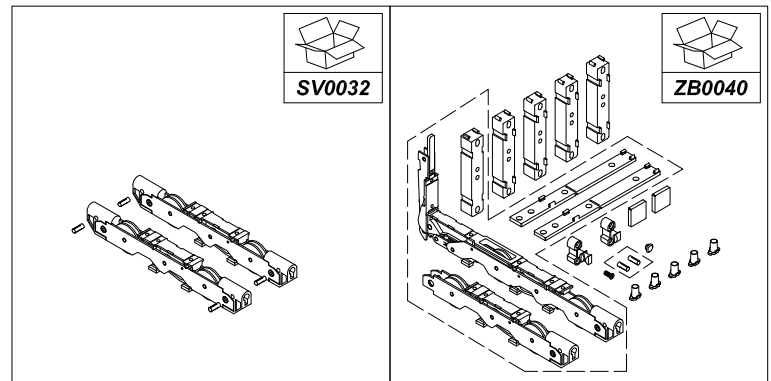
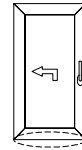

**ASSEMBLAGGIO FERRAMENTA ANTA**

**PREPARAZIONE CARRELLI ALZANTE-SCORREVOLE (300 - 400 kg)**

4 / 9

300 kg <  ≤ 400 kg

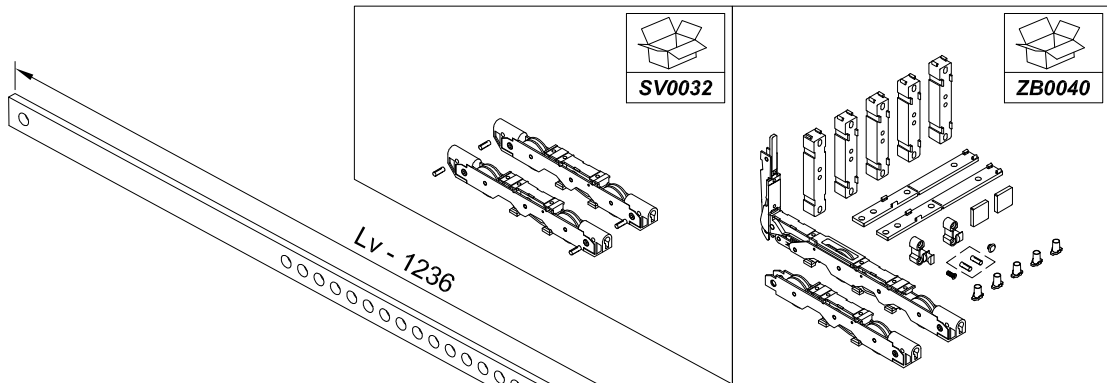
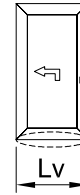

$1316 \leq Lv \leq 1500$	<b>ZB0029</b>
$1501 \leq Lv \leq 2000$	<b>ZB0030</b>
$2001 \leq Lv \leq 2500$	<b>ZB0031</b>
$2501 \leq Lv \leq 3235$	<b>ZB0032</b>

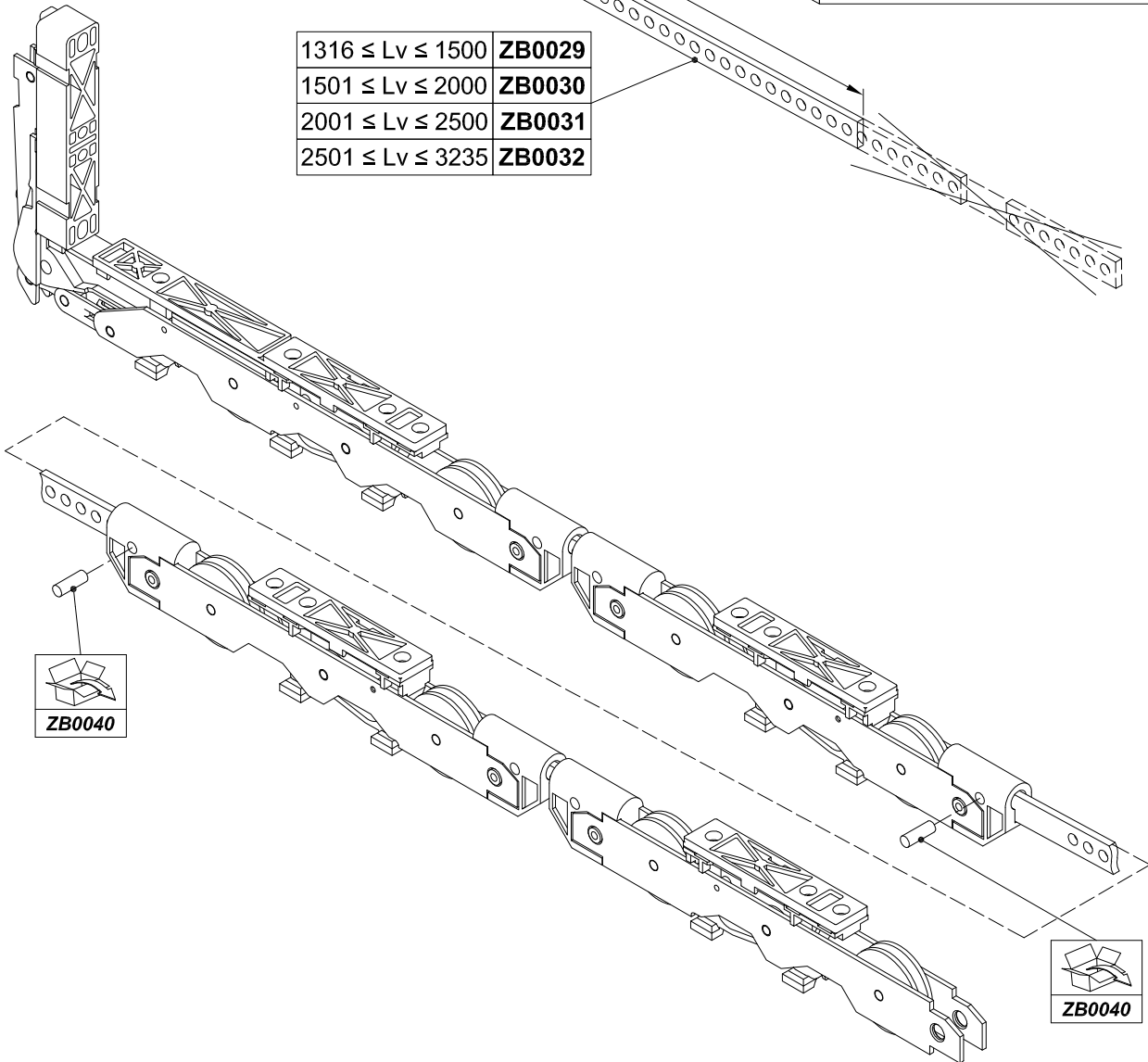

## ASSEMBLAGGIO FERRAMENTA ANTA

### PREPARAZIONE CARRELLI ALZANTE-SCORREVOLE

5 / 9



≤ 300 kg

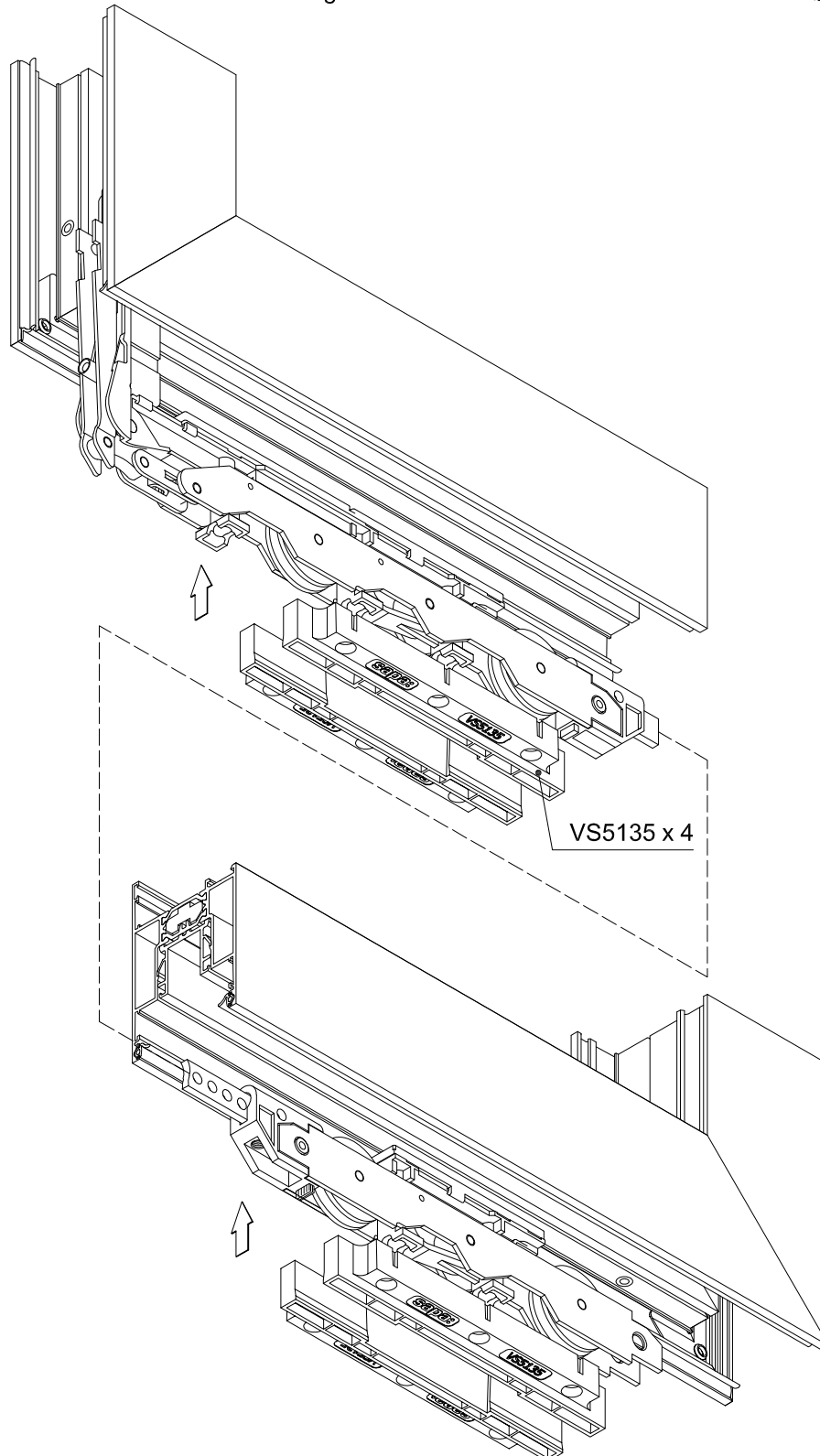
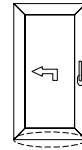

**PREPARAZIONE CARRELLI ALZANTE-SCORREVOLE**

6 / 9



≤ 300 kg

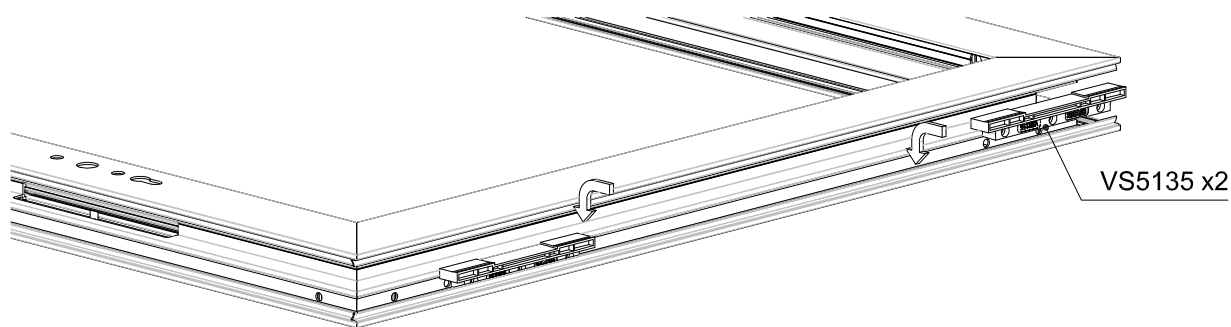
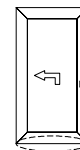

VS5135 x2

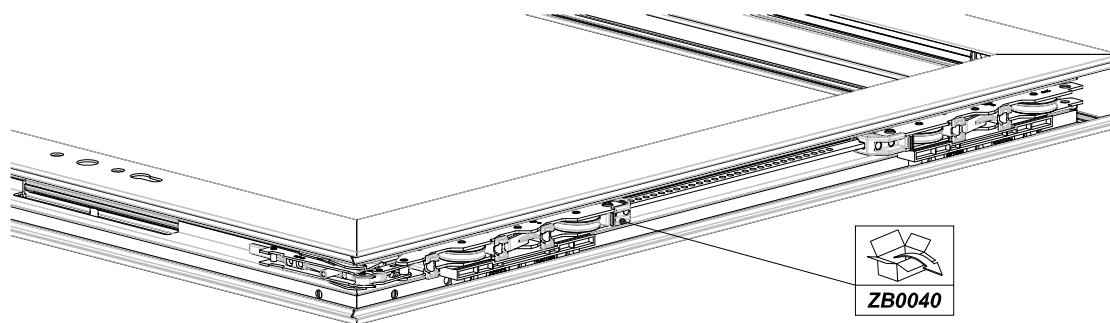

ZB0040

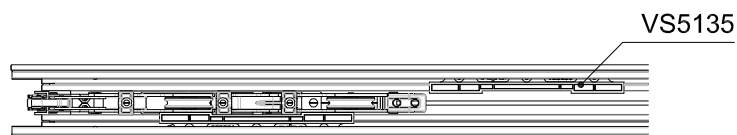

VS5135

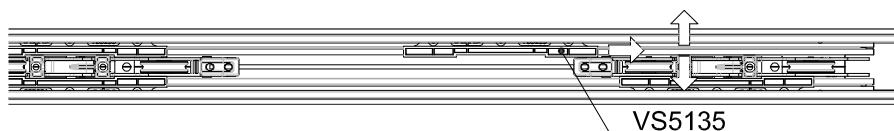

VS5135



## ASSEMBLAGGIO FERRAMENTA ANTA

### PREPARAZIONE CARRELLI ALZANTE-SCORREVOLE

7 / 9



≤ 300 kg

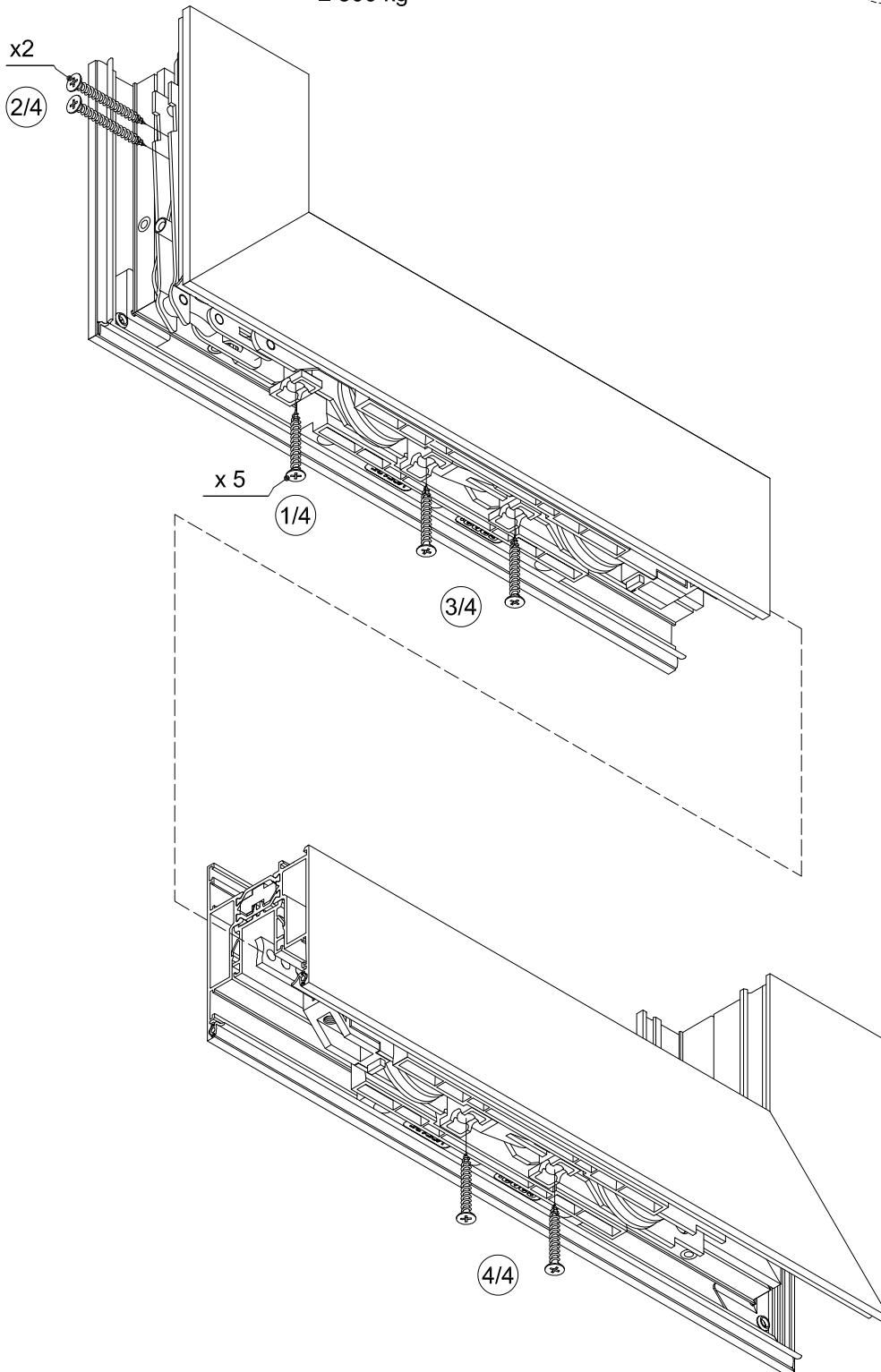
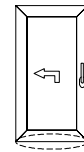

**PREPARAZIONE CARRELLI ALZANTE-SCORREVOLI**

8 / 9

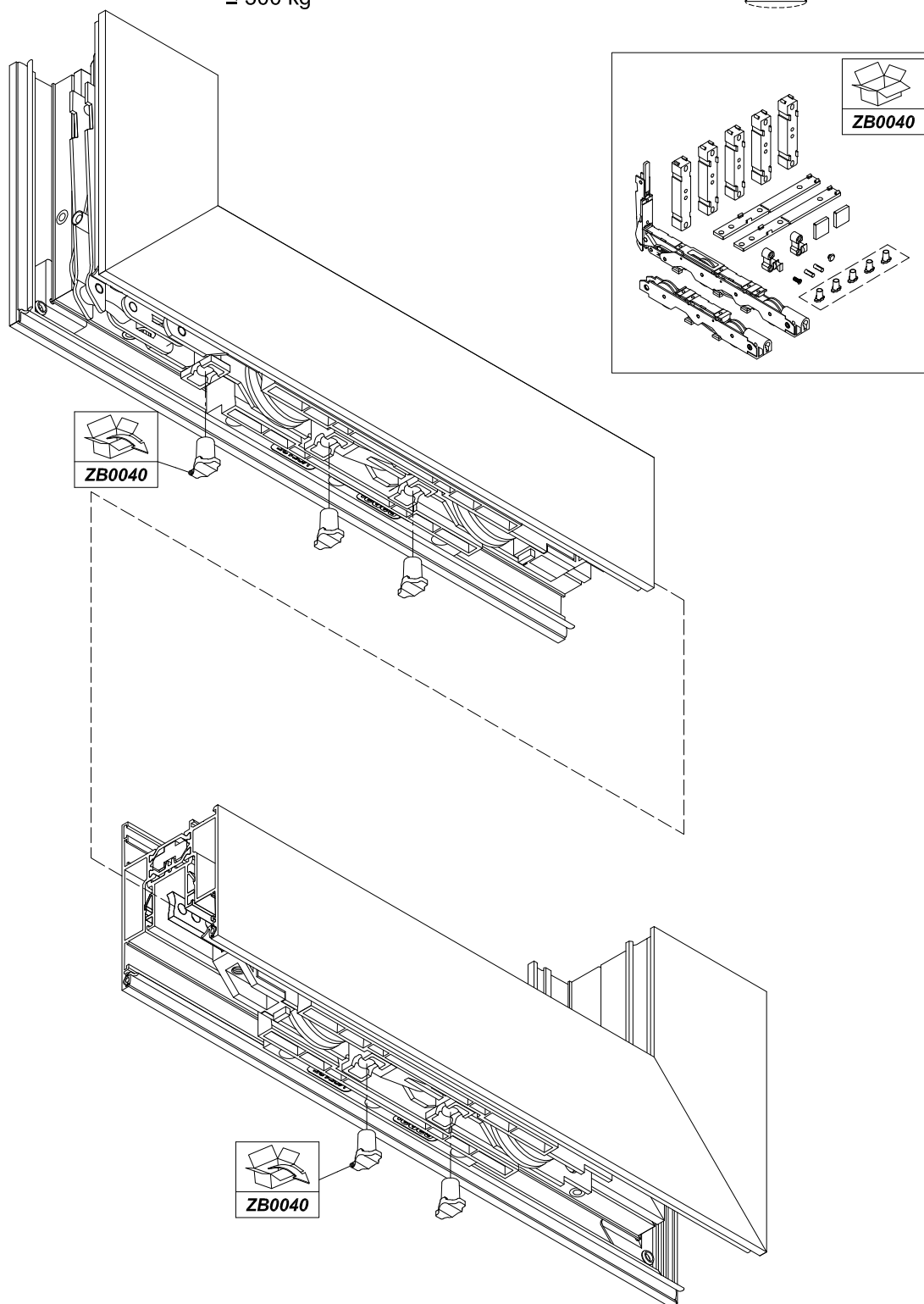
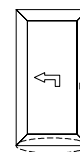

## ASSEMBLAGGIO FERRAMENTA ANTA

### PREPARAZIONE CARRELLI ALZANTE-SCORREVOLE

9 / 9



≤ 300 kg

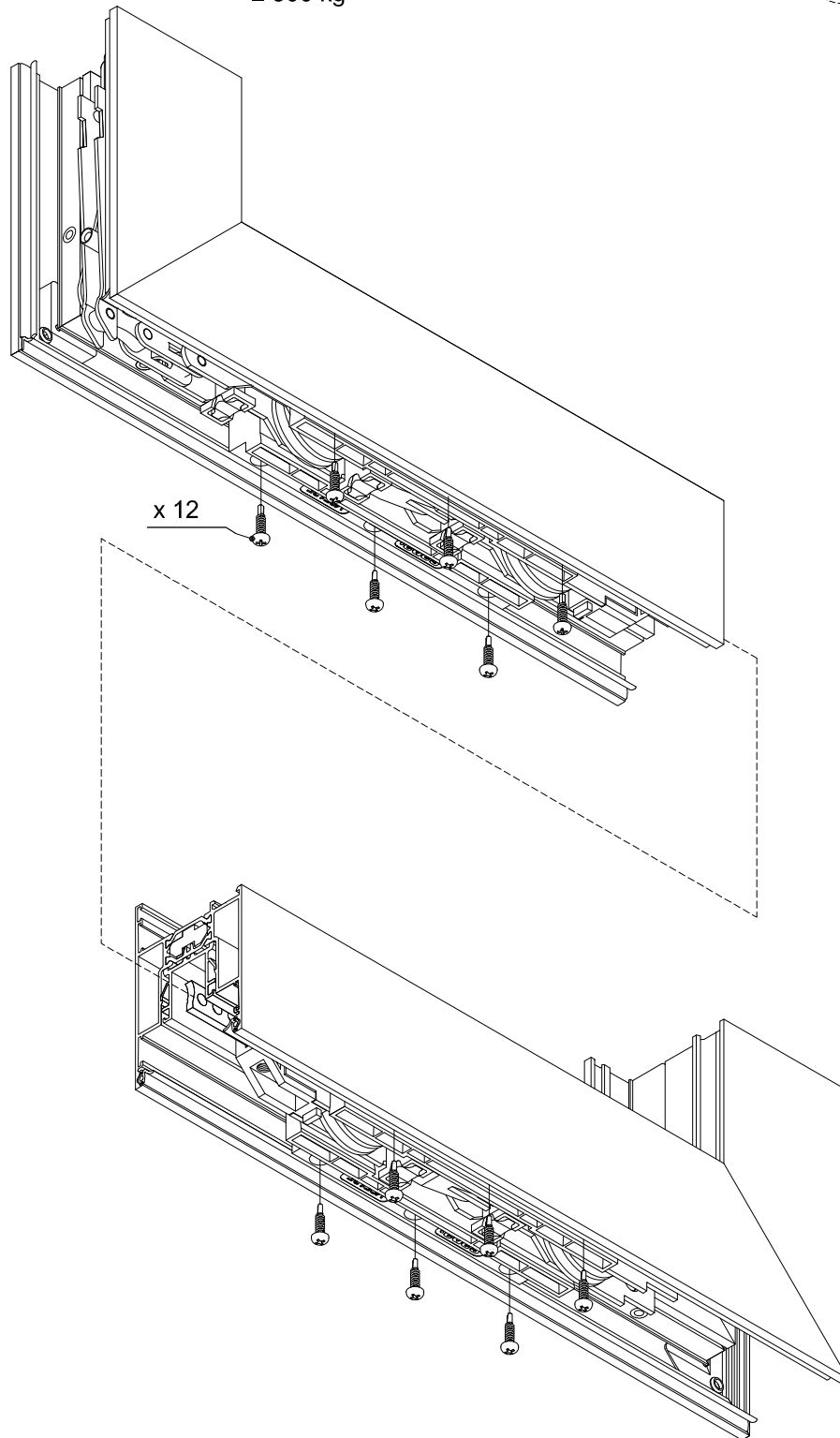
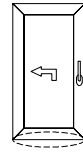

**PREPARAZIONE ZB0033/ZB0034/ZB0035/ZB0036**

1 / 8

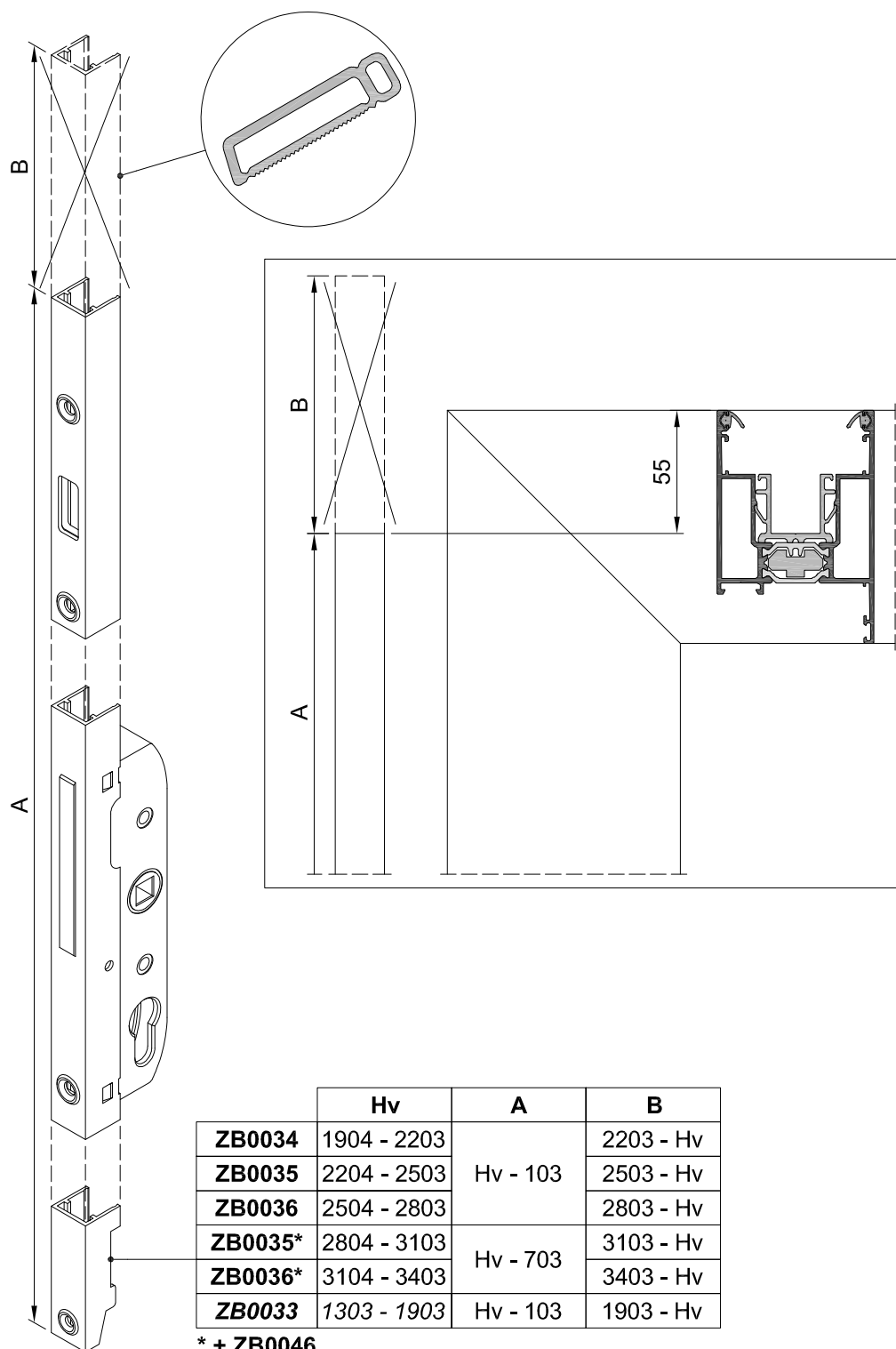
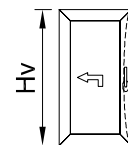

## ASSEMBLAGGIO FERRAMENTA ANTA

### PREPARAZIONE ZB0033/ZB0034/ZB0035/ZB0036 - MANIGLIA INTERNA

2 / 8

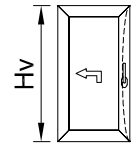

	Hv
<b>ZB0034</b>	1904 - 2203
<b>ZB0035</b>	2204 - 2503
<b>ZB0036</b>	2504 - 2803
<b>ZB0035*</b>	2804 - 3103
<b>ZB0036*</b>	3104 - 3403
<b>ZB0033</b>	1303 - 1903

\* + ZB0046

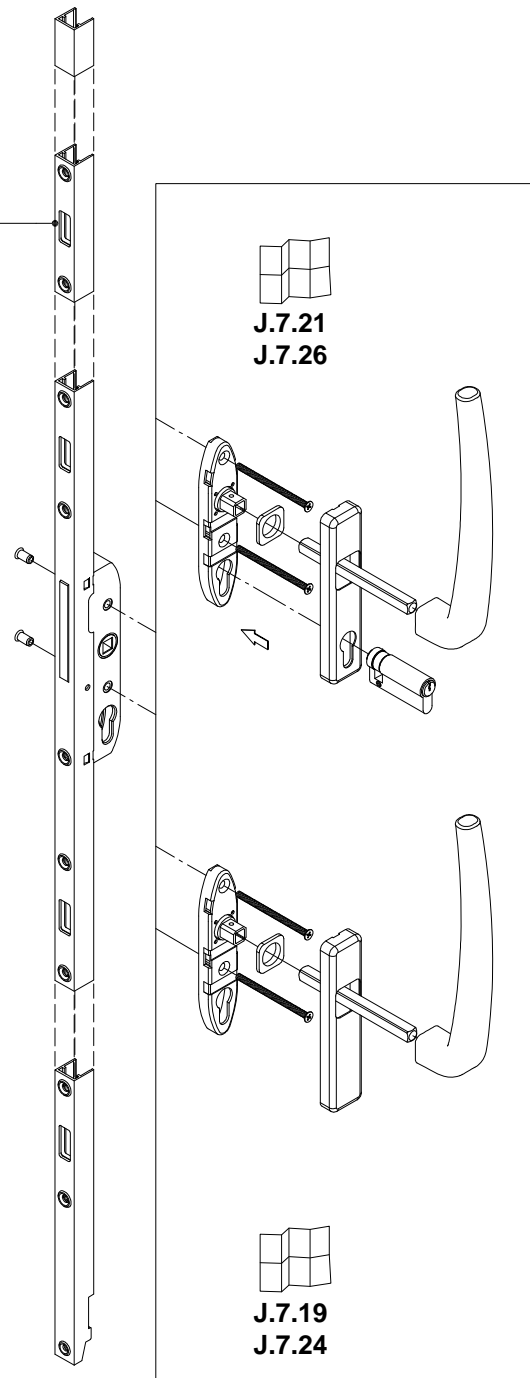
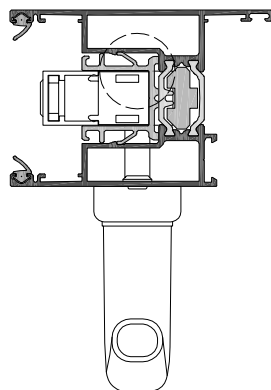
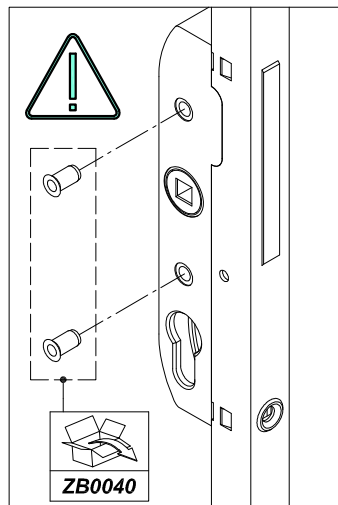

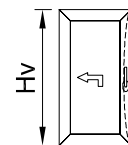

**ASSEMBLAGGIO ZB0053/ZB0054 - SOLLEVAMENTO SERVO ASSISTITO**

3 / 8



	Hv
<b>ZB0034</b>	1904 - 2203
<b>ZB0035</b>	2204 - 2503
<b>ZB0036</b>	2504 - 2803
<b>ZB0035*</b>	2804 - 3103
<b>ZB0036*</b>	3104 - 3403
<b>ZB0033</b>	1303 - 1903

\* + ZB0046

<b>ZB0053</b>	 = 100 kg - 200 kg
<b>ZB0054</b>	 = 201 kg - 400 kg

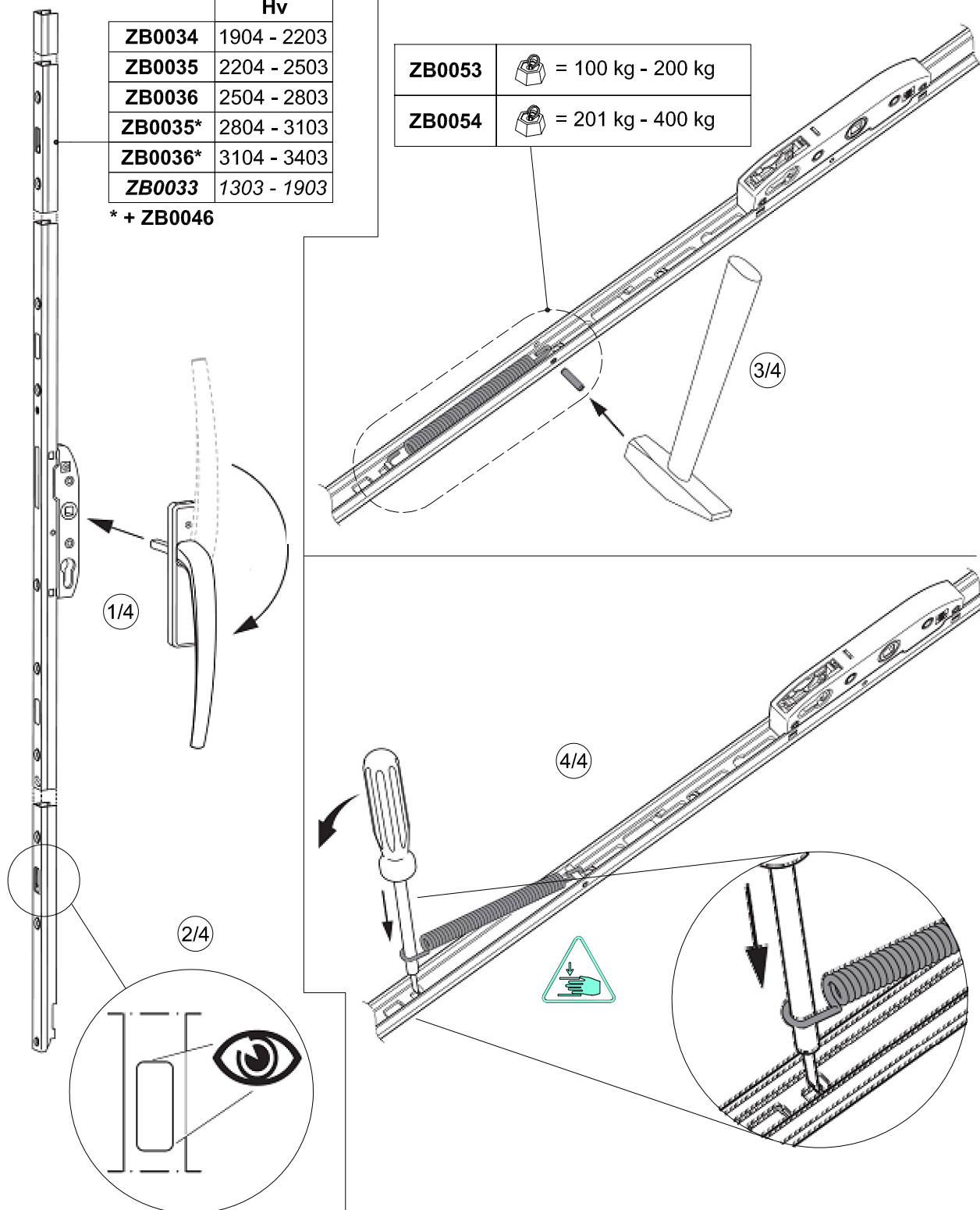

 **C160-ASS-2156L**

## ASSEMBLAGGIO FERRAMENTA ANTA

### PREPARAZIONE ZB0046

4 / 8

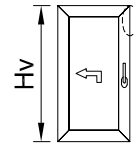

	Hv	B
ZB0035*	2804 - 3103	3103 - Hv
ZB0036*	3104 - 3403	3403 - Hv

\* + ZB0046

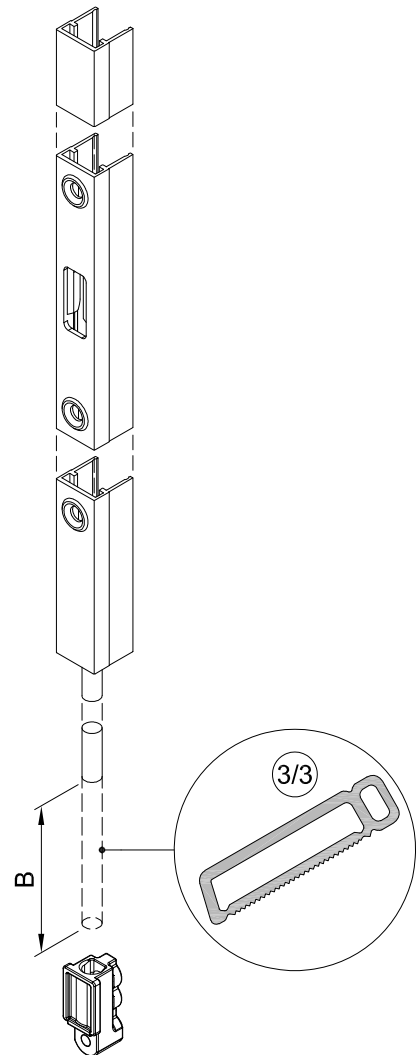
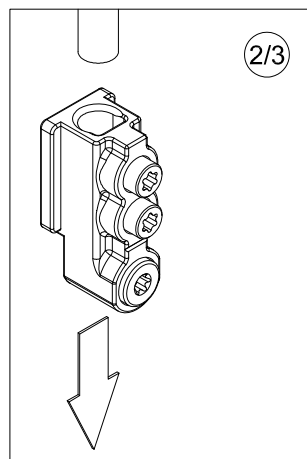
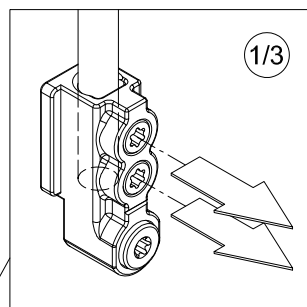
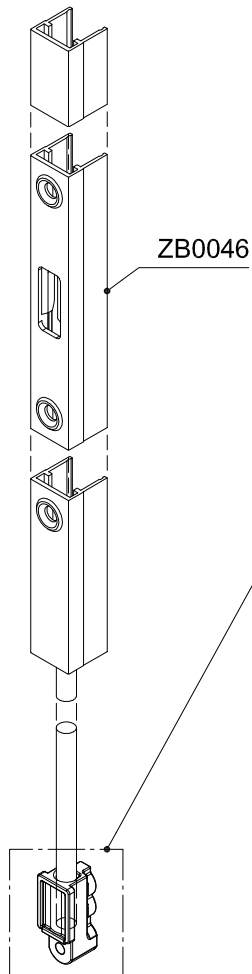

**ASSEMBLAGGIO ZB0035/ZB0036 CON ZB0046**

5 / 8

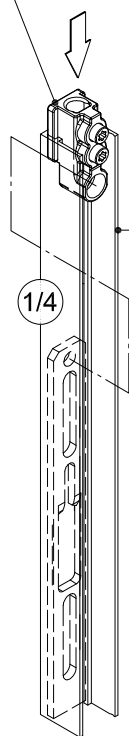
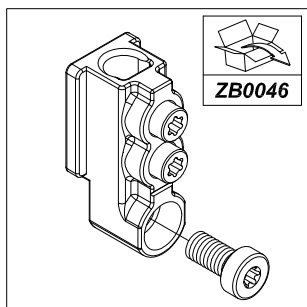
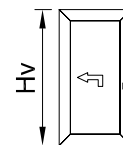

	Hv
ZB0035*	2804 - 3103
ZB0036*	3104 - 3403

\* + ZB0046

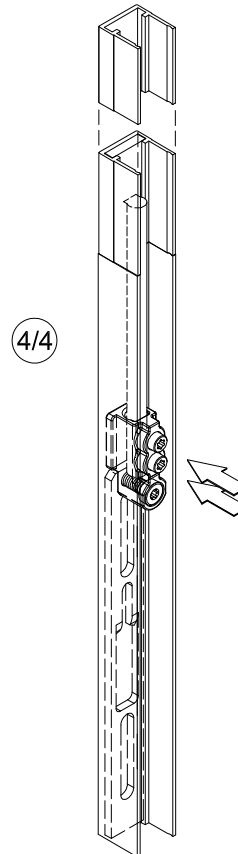
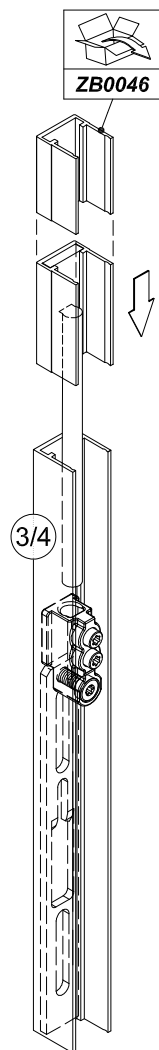
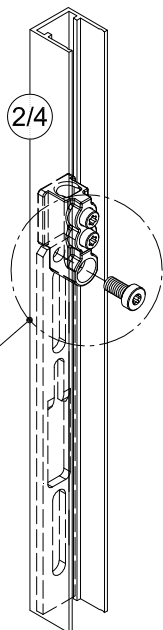
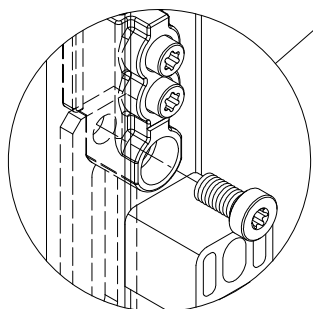



## ASSEMBLAGGIO FERRAMENTA ANTA

### ASSEMBLAGGIO MECCANISMO CHIUSURA ALZANTE-SCORREVOLE

6 / 8

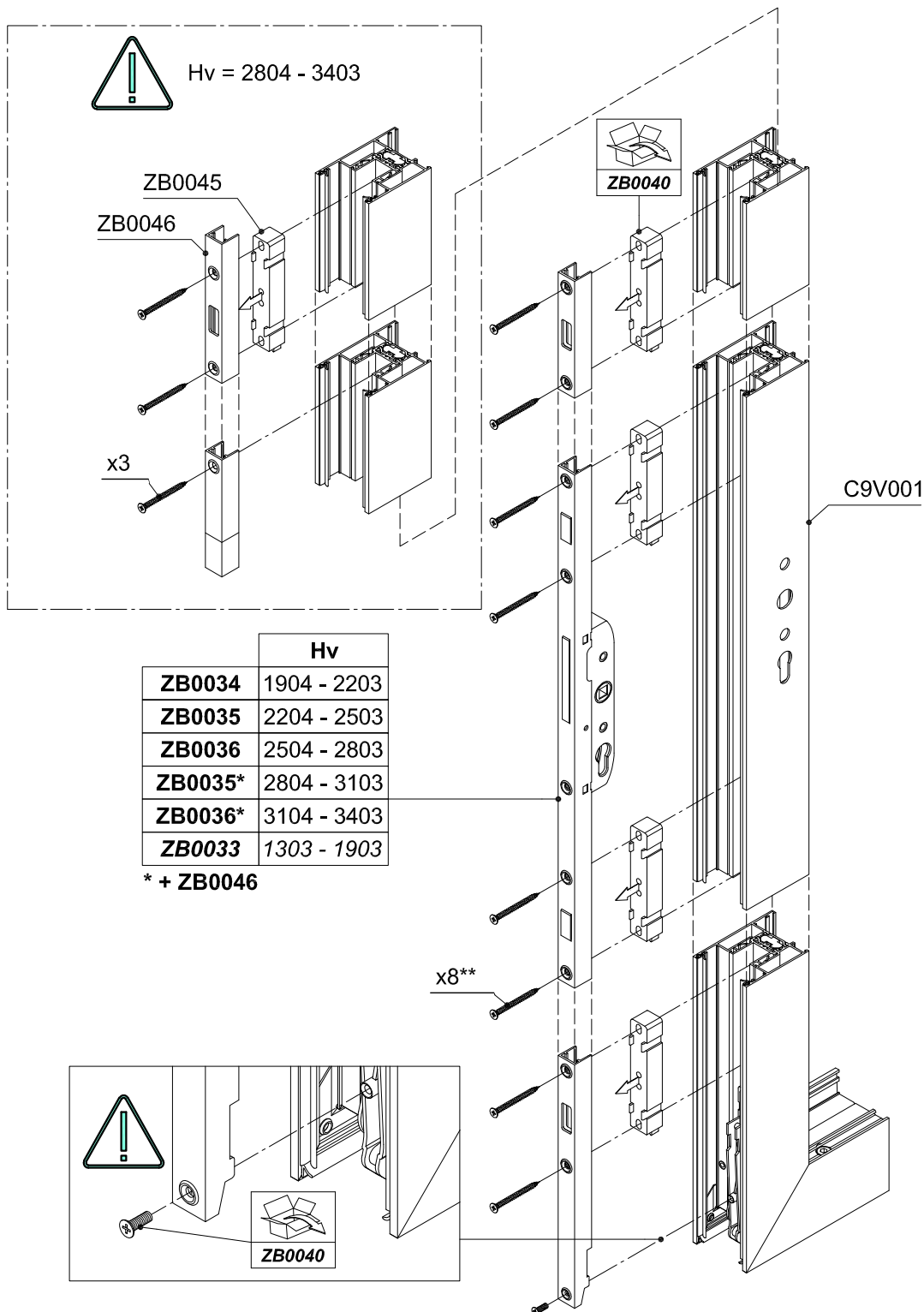
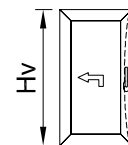

**ASSEMBLAGGIO MECCANISMO CHIUSURA ALZANTE-SCORREVOLE - ANTA PASSIVA SCHEMA 4 ANTE**

7 / 8

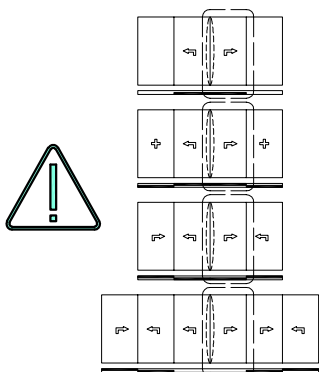
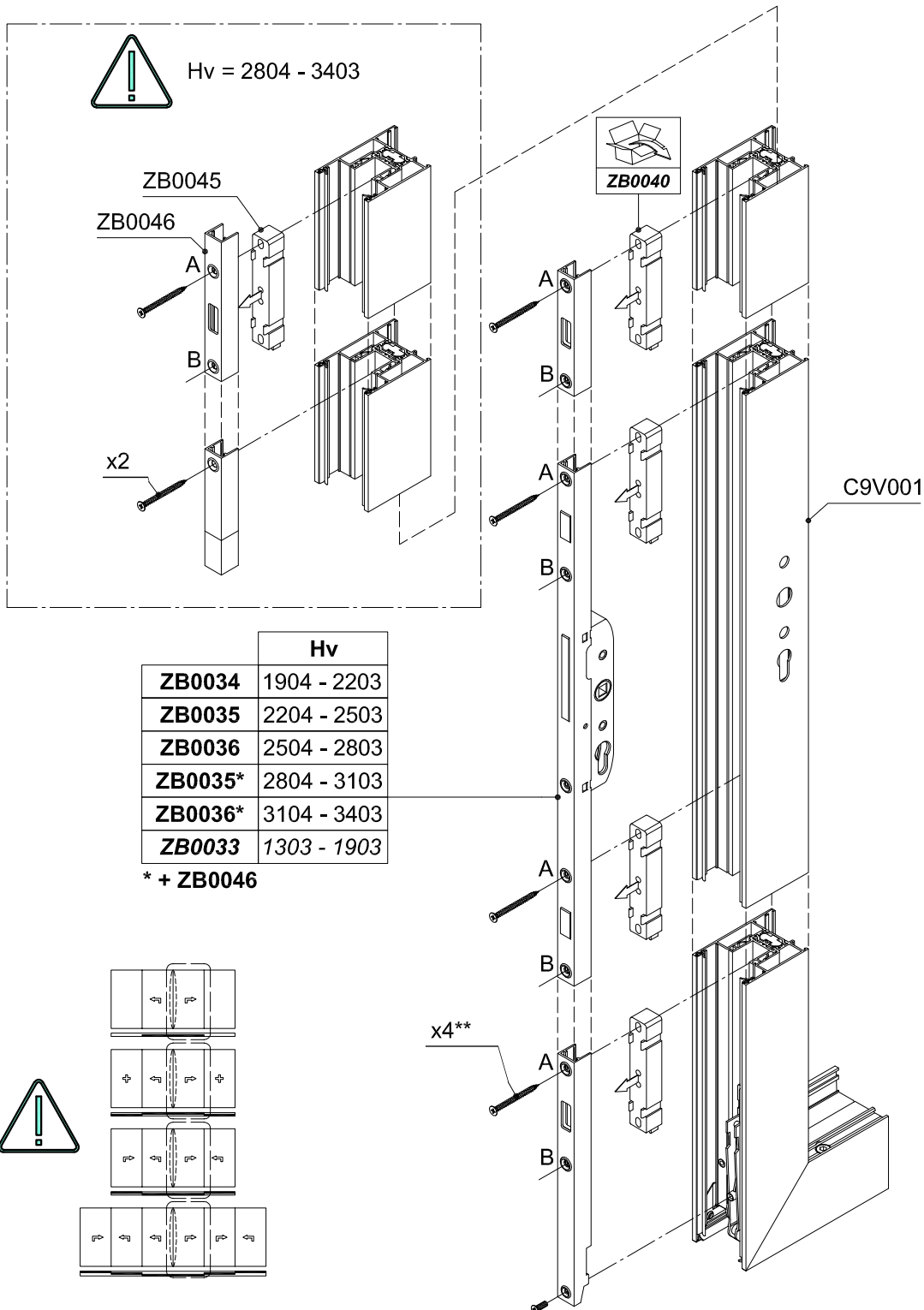
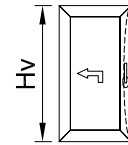

## ASSEMBLAGGIO FERRAMENTA ANTA

### INSTALLAZIONE MANIGLIA INTERNA STANDARD ALZANTE-SCORREVOLE

1 / 5

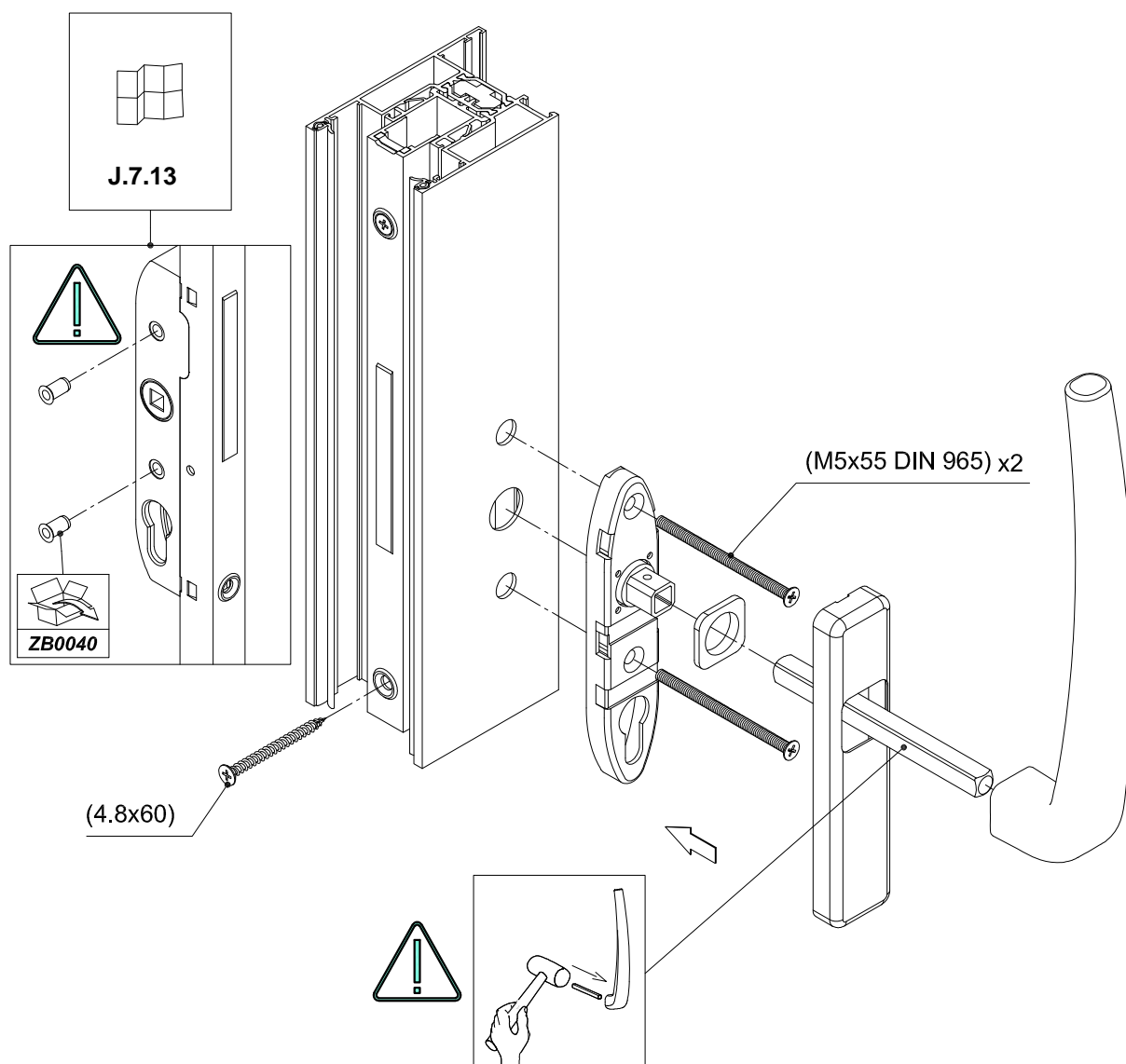
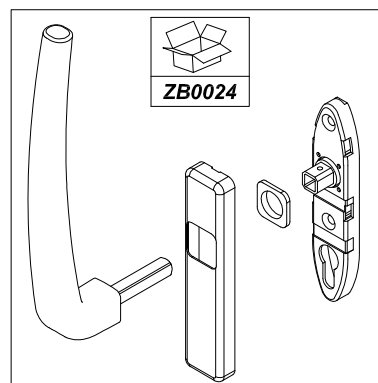
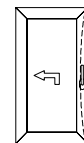

**INSTALLAZIONE MANIGLIA INTERNA STANDARD E VASCHETTA ESTERNA ALZANTE-SCORREVOLE**

2 / 5

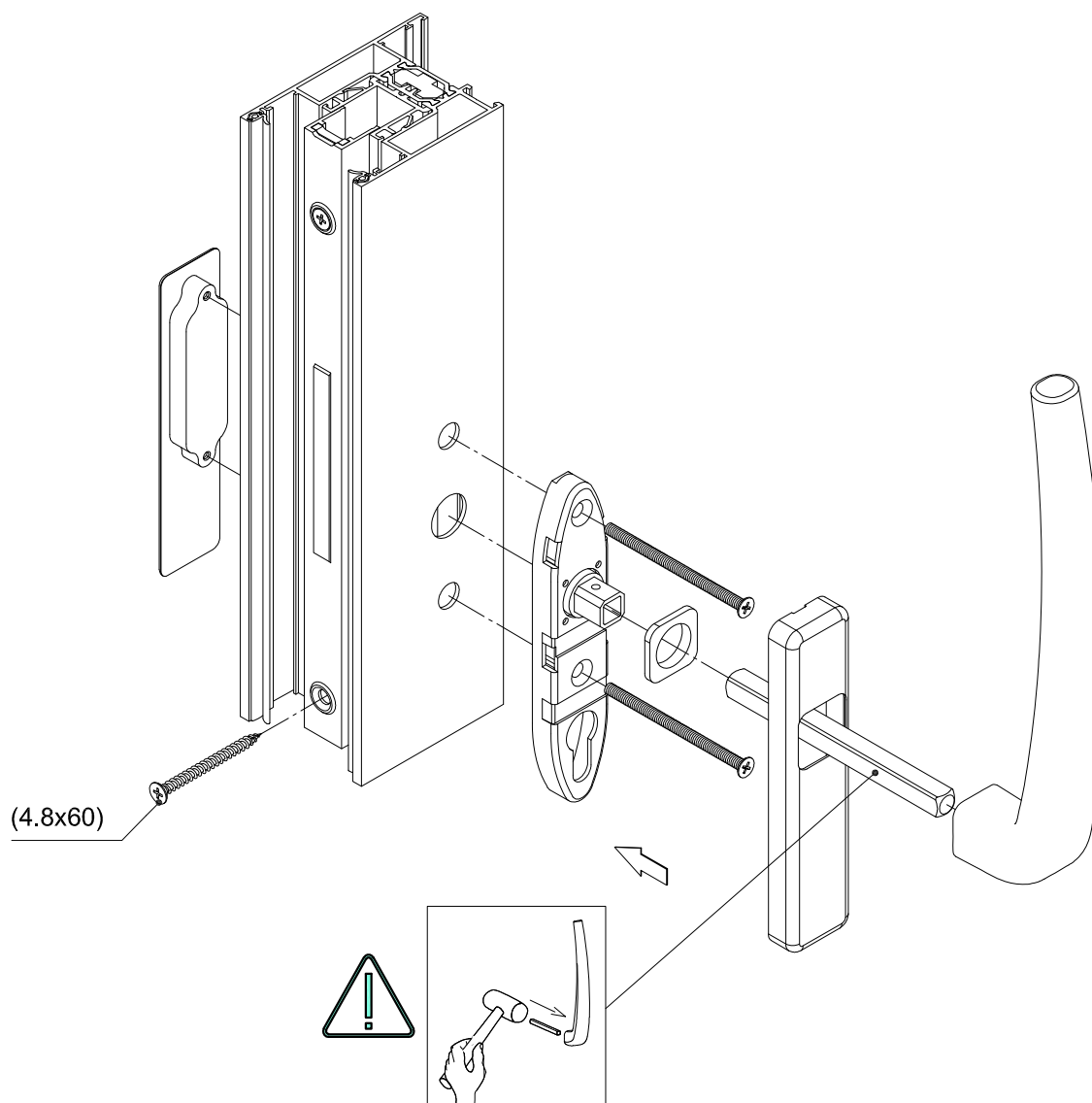
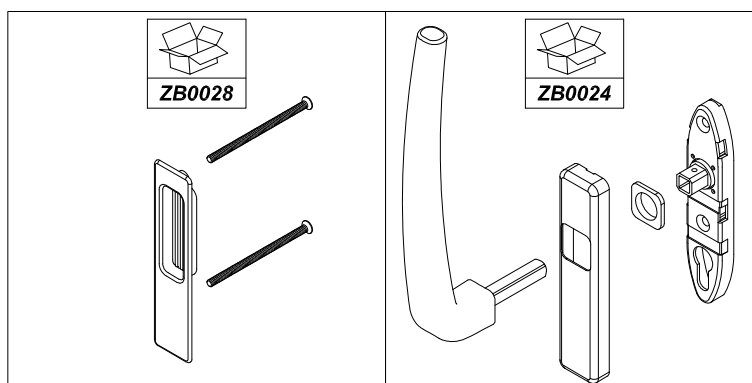
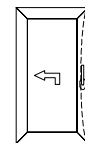

## ASSEMBLAGGIO FERRAMENTA ANTA

### INSTALLAZIONE MANIGLIA INTERNA STANDARD CON MEZZO CILINDRO ALZANTE-SCORREVOLE

3 / 5

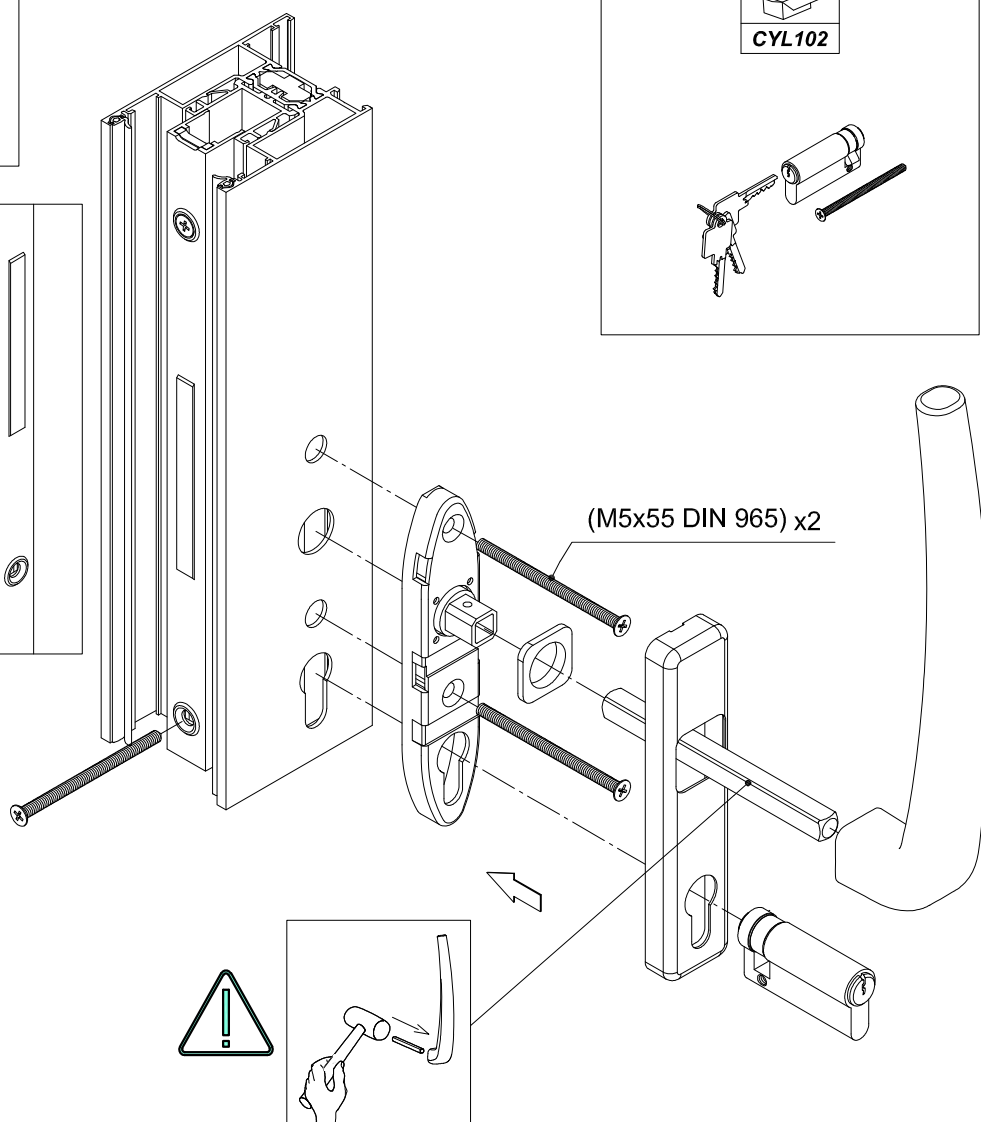
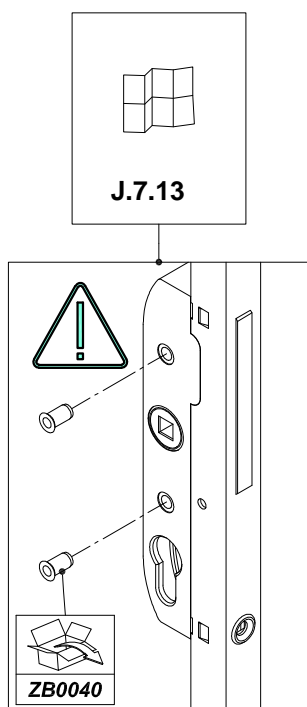
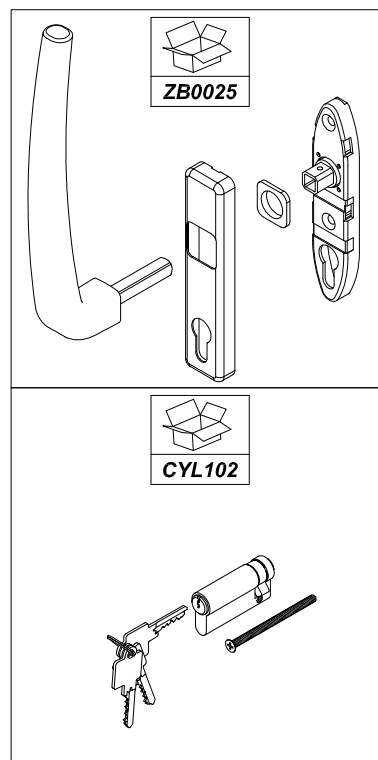
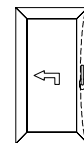

**MANIGLIA INTERNA STANDARD CON MEZZO CILINDRO E VASCHETTA ALZANTE-SCORREVOLE**

4 / 5

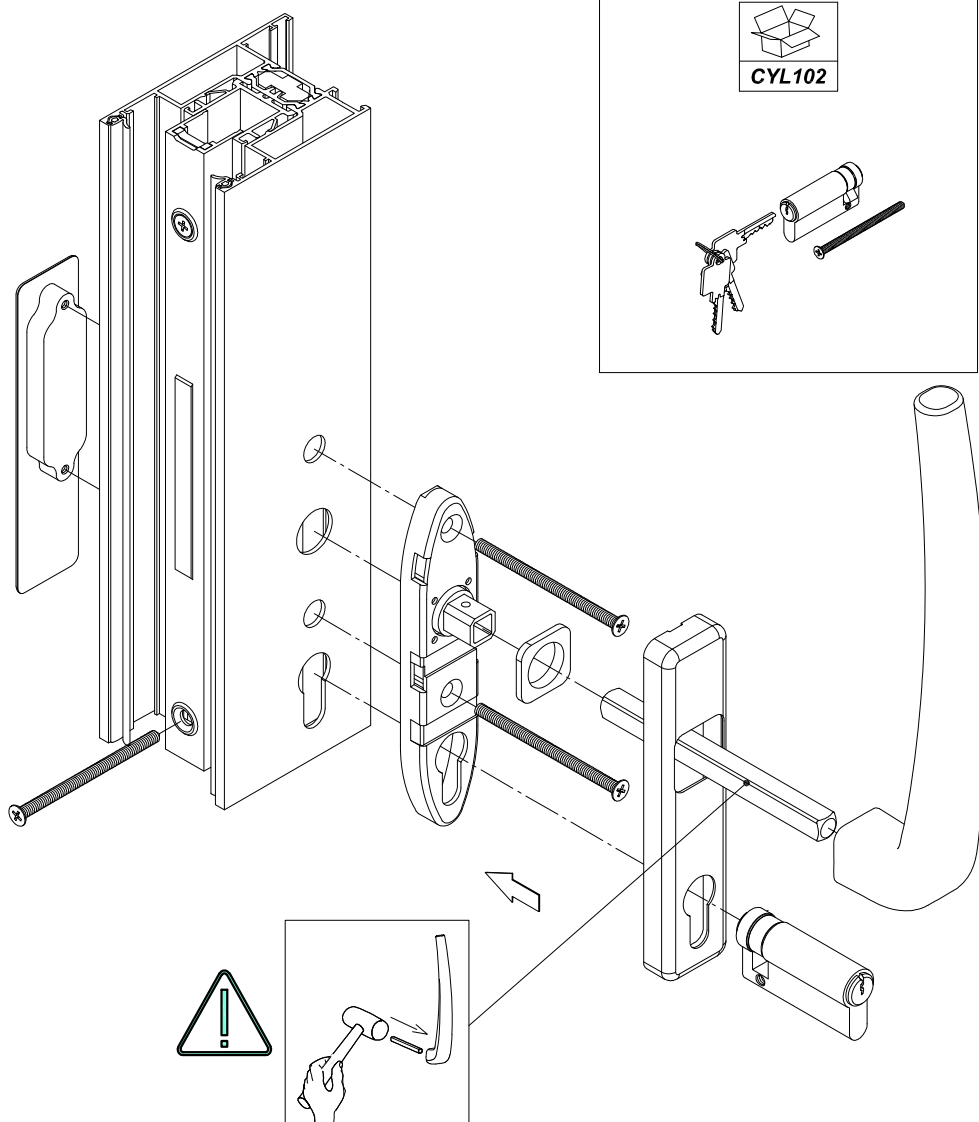
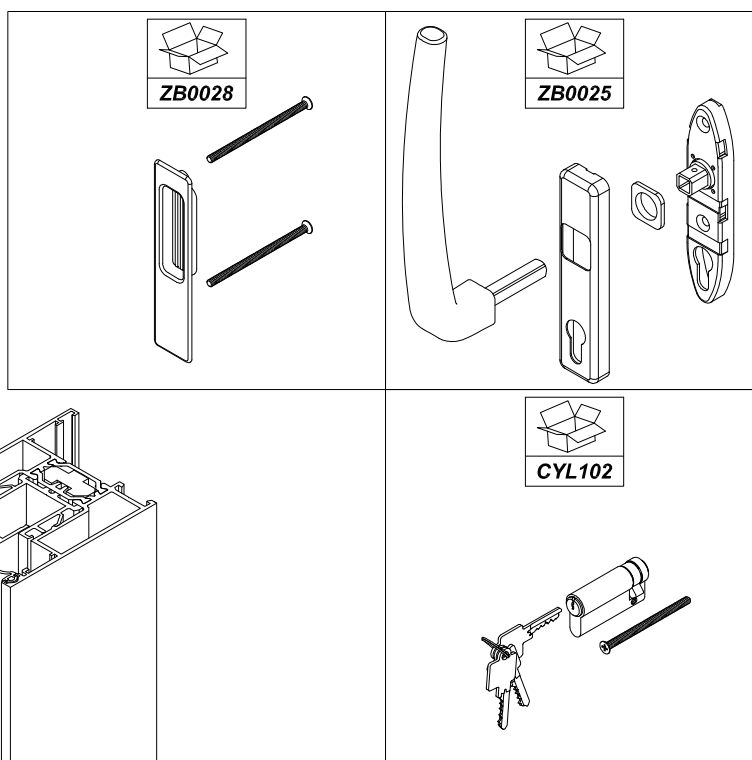
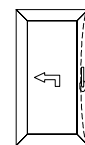

## ASSEMBLAGGIO FERRAMENTA ANTA

### INSTALLAZIONE MANIGLIA STANDARD SU DUE LATI CON CILINDRO ALZANTE-SCORREVOLE

5 / 5

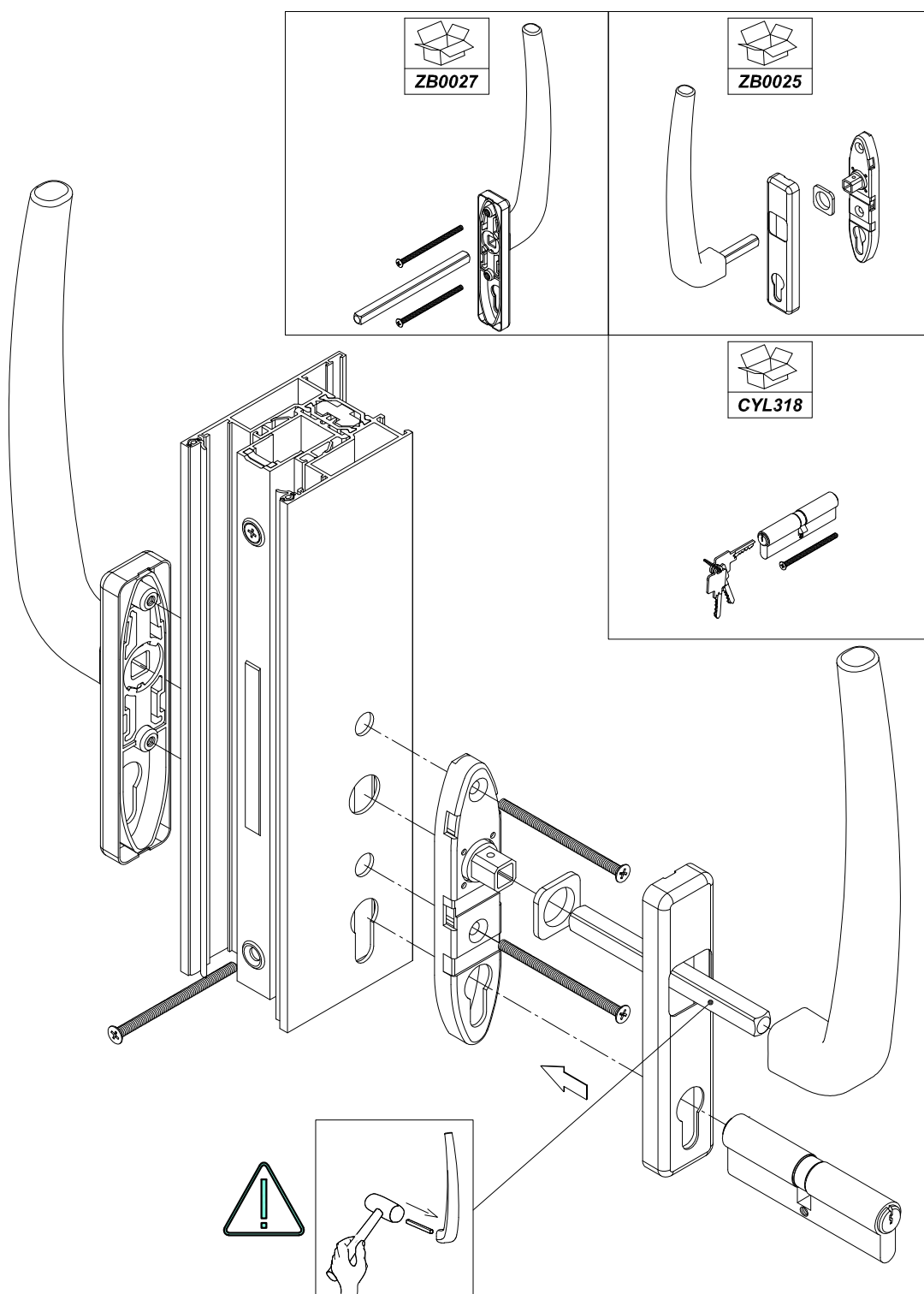
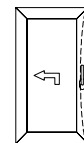

**INSTALLAZIONE MANIGLIA INTERNA S-LINE HARMONY ALZANTE-SCORREVOLE**

1 / 5

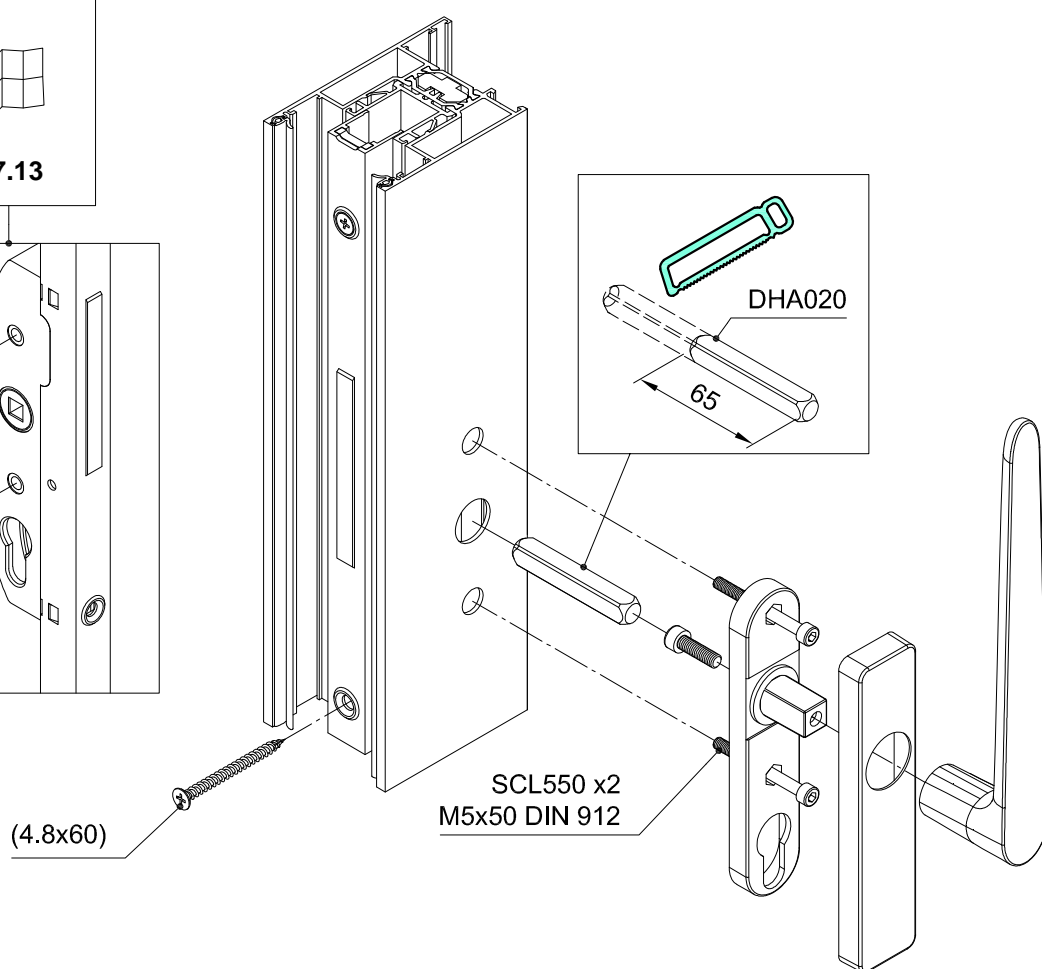
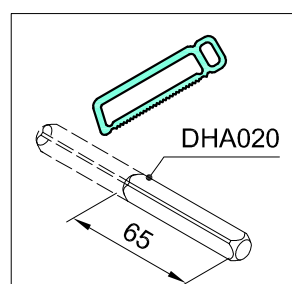
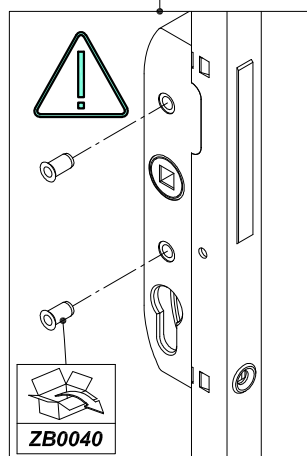
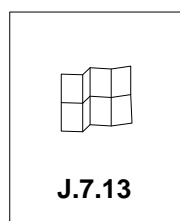
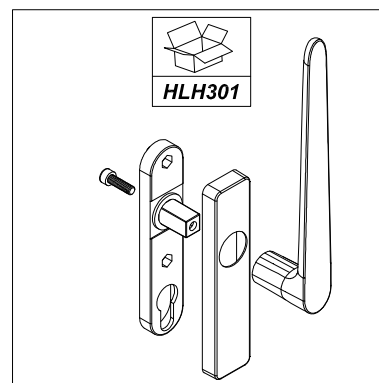
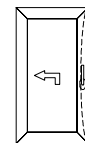



## ASSEMBLAGGIO FERRAMENTA ANTA

### MANIGLIA INTERNA S-LINE HARMONY E VASCHETTA ESTERNA ALZANTE-SCORREVOLE

2 / 5

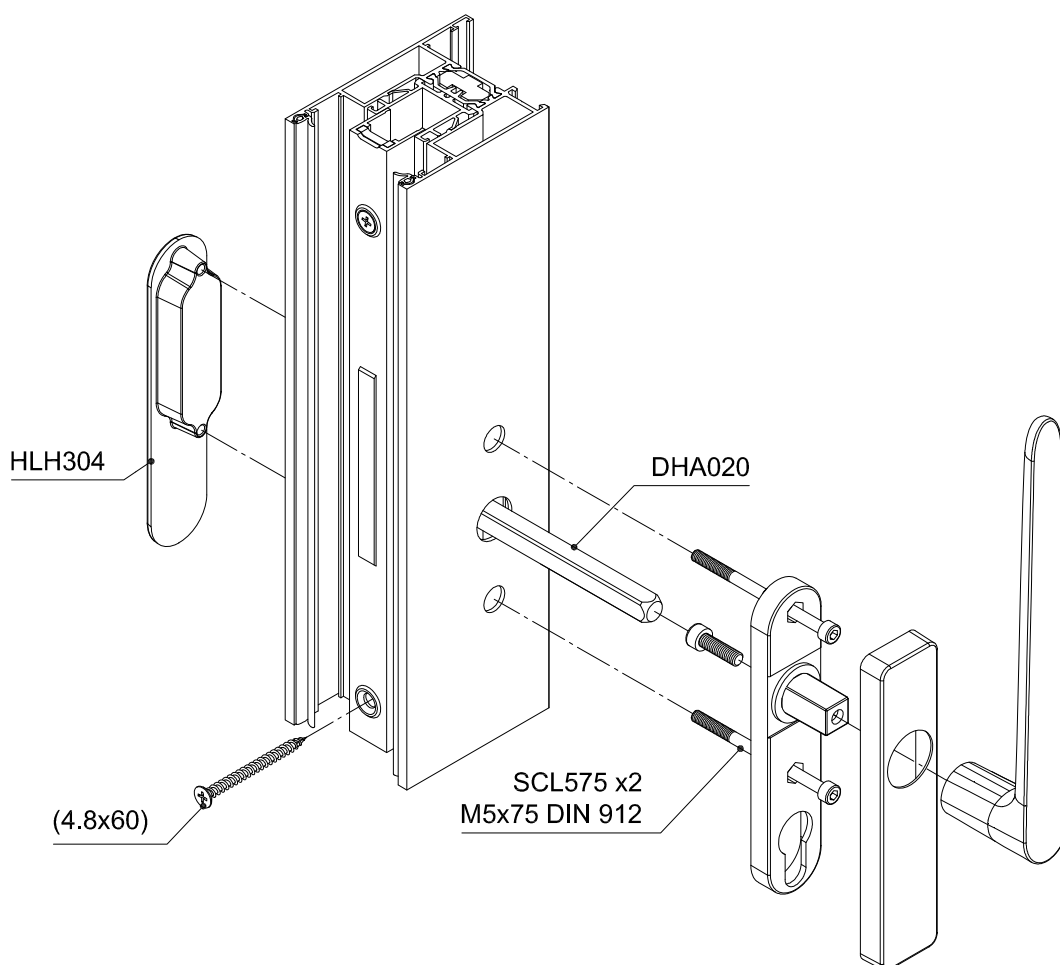
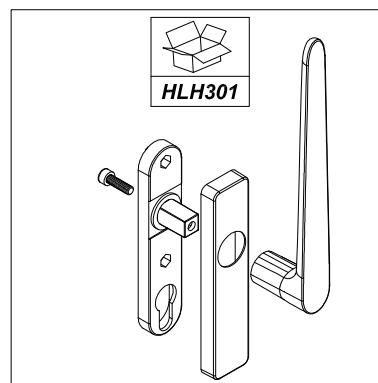
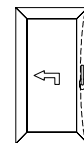

**INSTALLAZIONE MANIGLIA INTERNA S-LINE HARMONY CON MEZZO CILINDRO ALZANTE-SCORREVOLE**

3 / 5

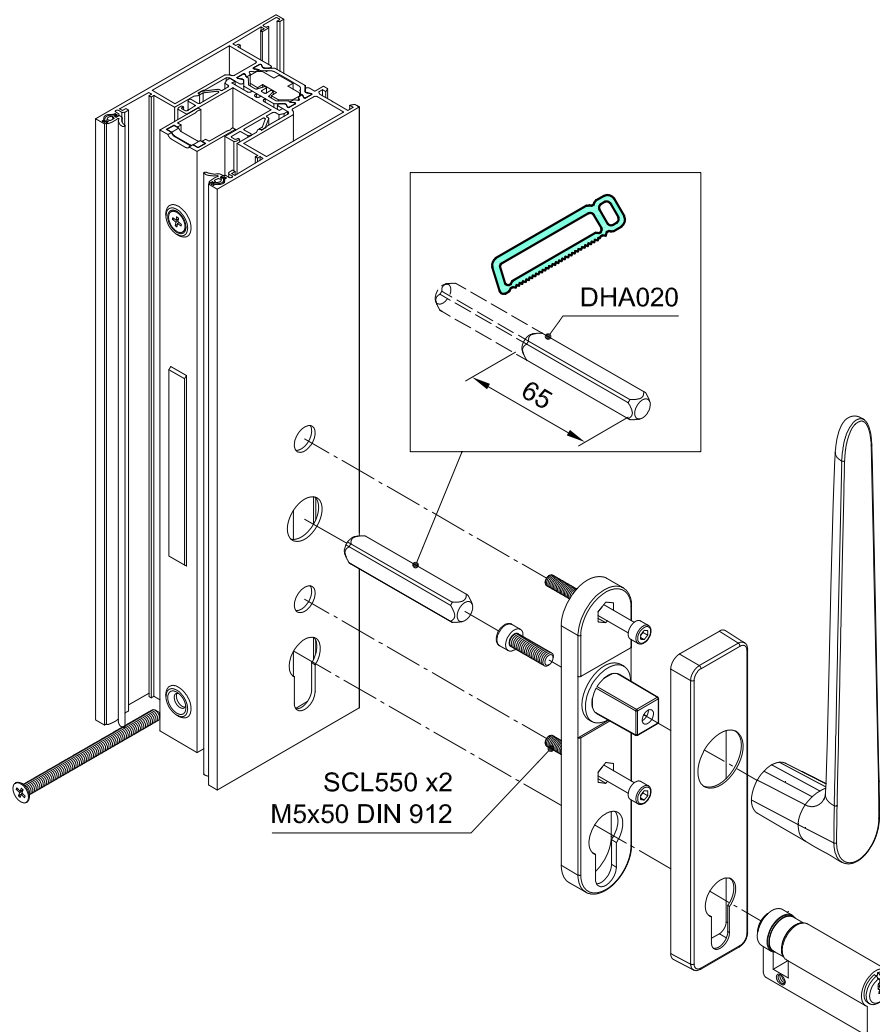
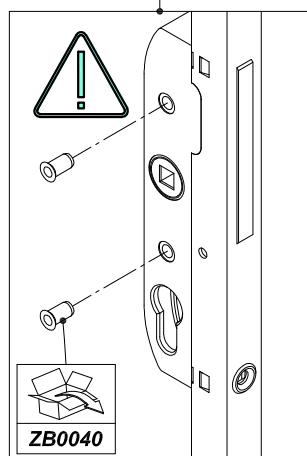
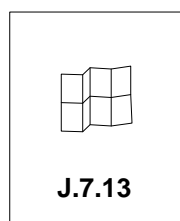
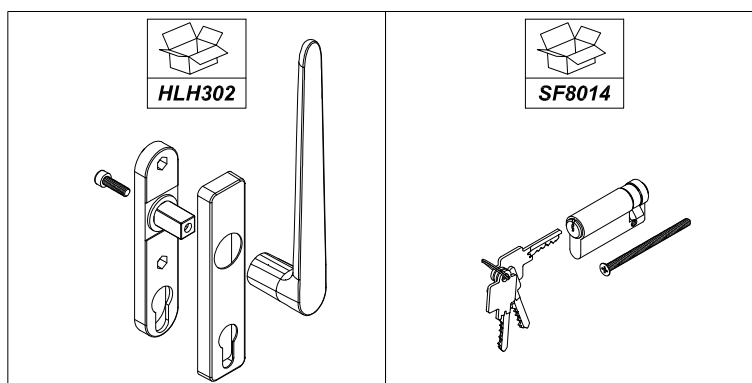
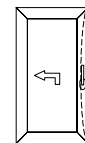

## ASSEMBLAGGIO FERRAMENTA ANTA

### MANIGLIA INTERNA S-LINE HARMONY CON MEZZO CILINDRO E VASCHETTA ALZANTE-SCORREVOLE

4 / 5

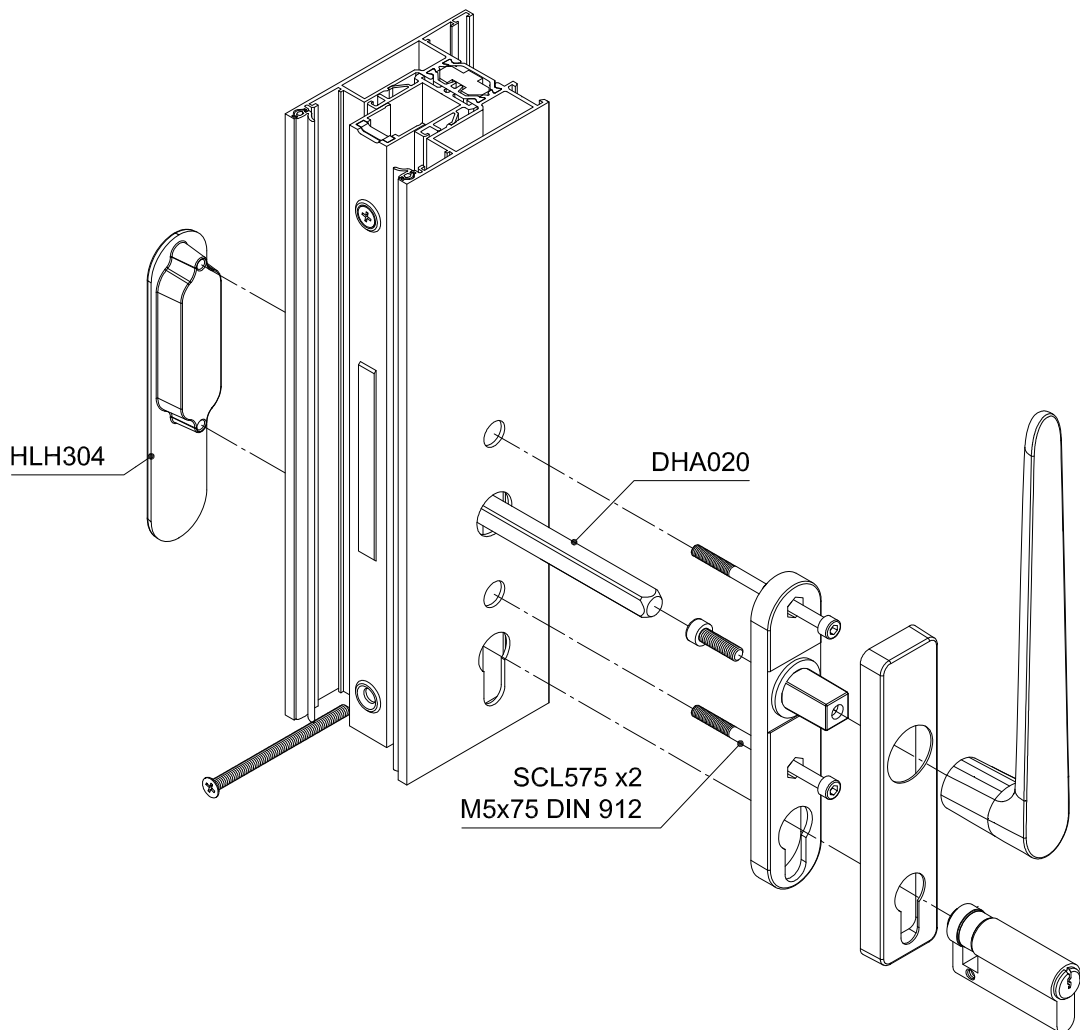
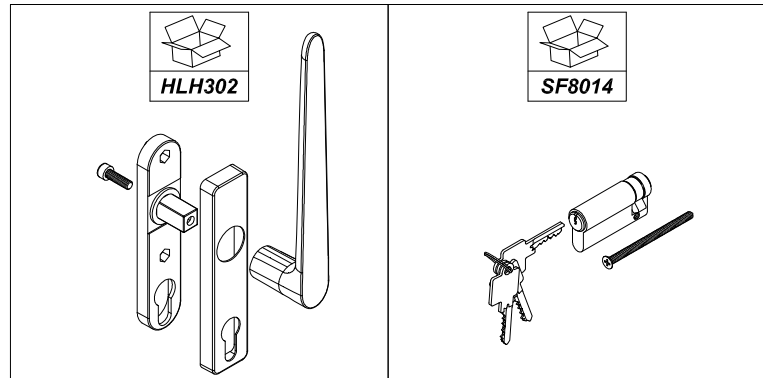
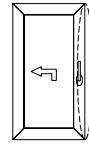

**INSTALLAZIONE MANIGLIA S-LINE HARMONY SU DUE LATI CON CILINDRO ALZANTE-SCORREVOLE**

5 / 5

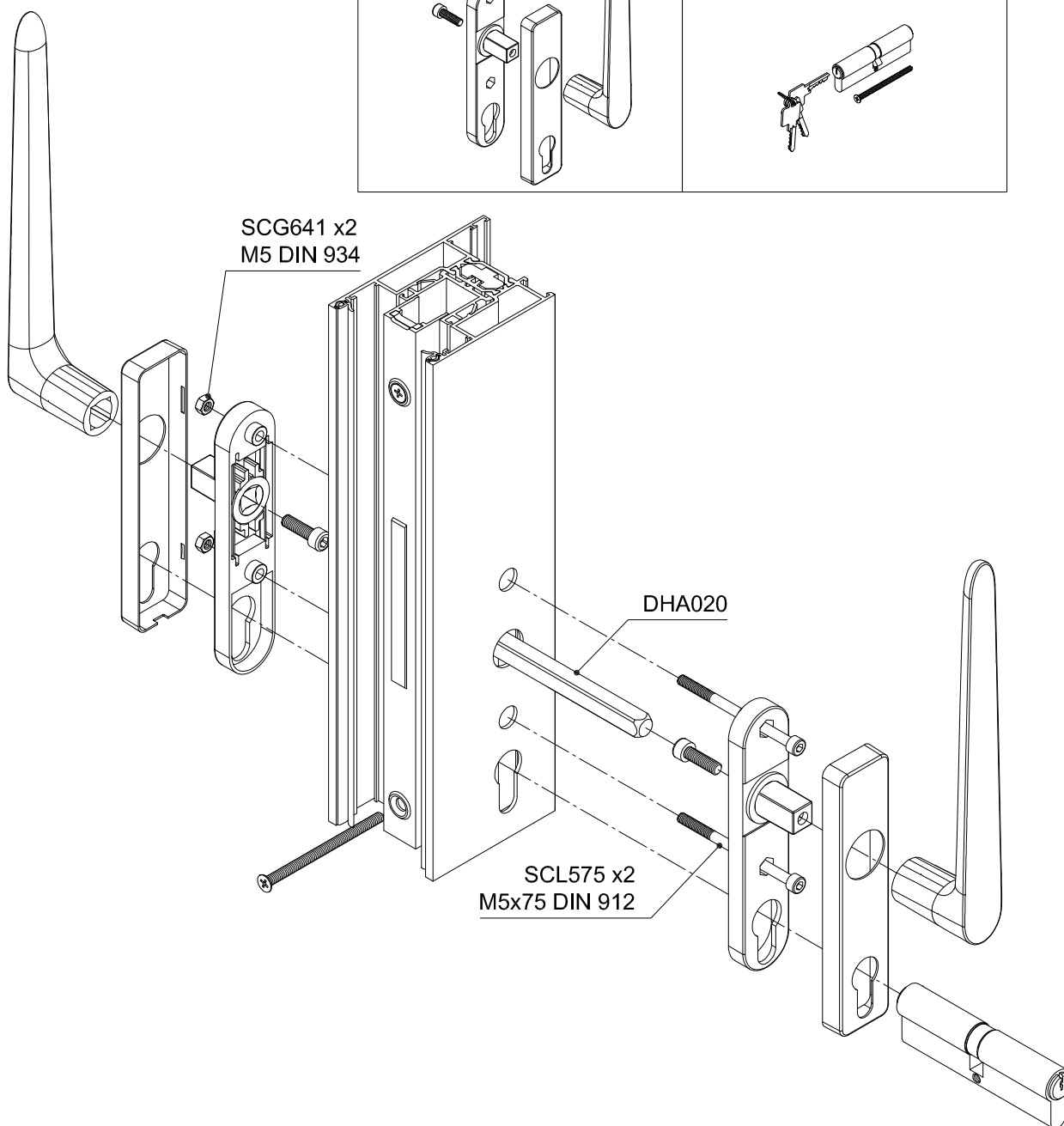
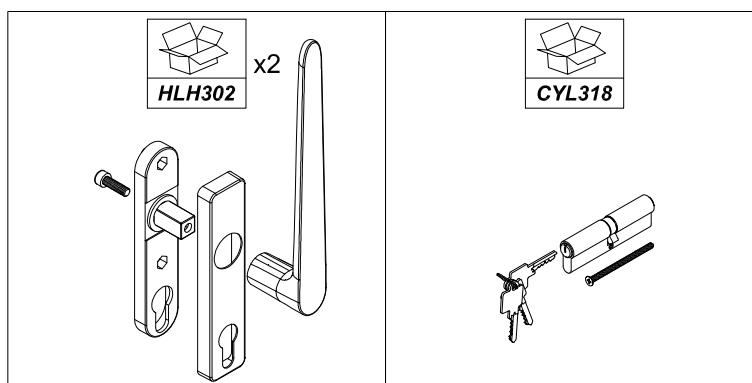
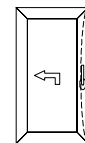

### CONTENUTO

Assemblaggio ferramenta anta - RC2.....	J.9.1
Contenuto.....	J.9.1
Ferramenta alzante-scorrevole panoramica.....	J.9.2
Assemblaggio CO2206.....	J.9.3
Preparazione ZB0033/ZB0034/ZB0035/ZB0036.....	J.9.4
Preparazione chiusura meccanismo alzante-scorrevole.....	J.9.5
Installazione ZB0033/ZB0034/ZB0035/ZB0036 - no maniglia esterna opzioni.....	J.9.6
Assemblaggio ZB0053/ZB0054 - optional.....	J.9.7
Preparazione ZB0046.....	J.9.8
Assemblaggio ZB0035/ZB0036 con ZB0046.....	J.9.9
Assemblaggio ZB0035/ZB0036/ZB0046 con ZB0048 e ZB0049/ZB0050.....	J.9.10
Assemblaggio ZB0048 con ZB0049/ZB0050.....	J.9.11
Assemblaggio ZB0035/ZB0036/ZB0046 con ZB0048.....	J.9.12
Installazione chiusura meccanismo alzante-scorrevole.....	J.9.13
Installazione chiusura meccanismo alzante-scorrevole - anta passiva schema 4 ante.....	J.9.15

**FERRAMENTA ALZANTE-SCORREVOLE PANORAMICA**

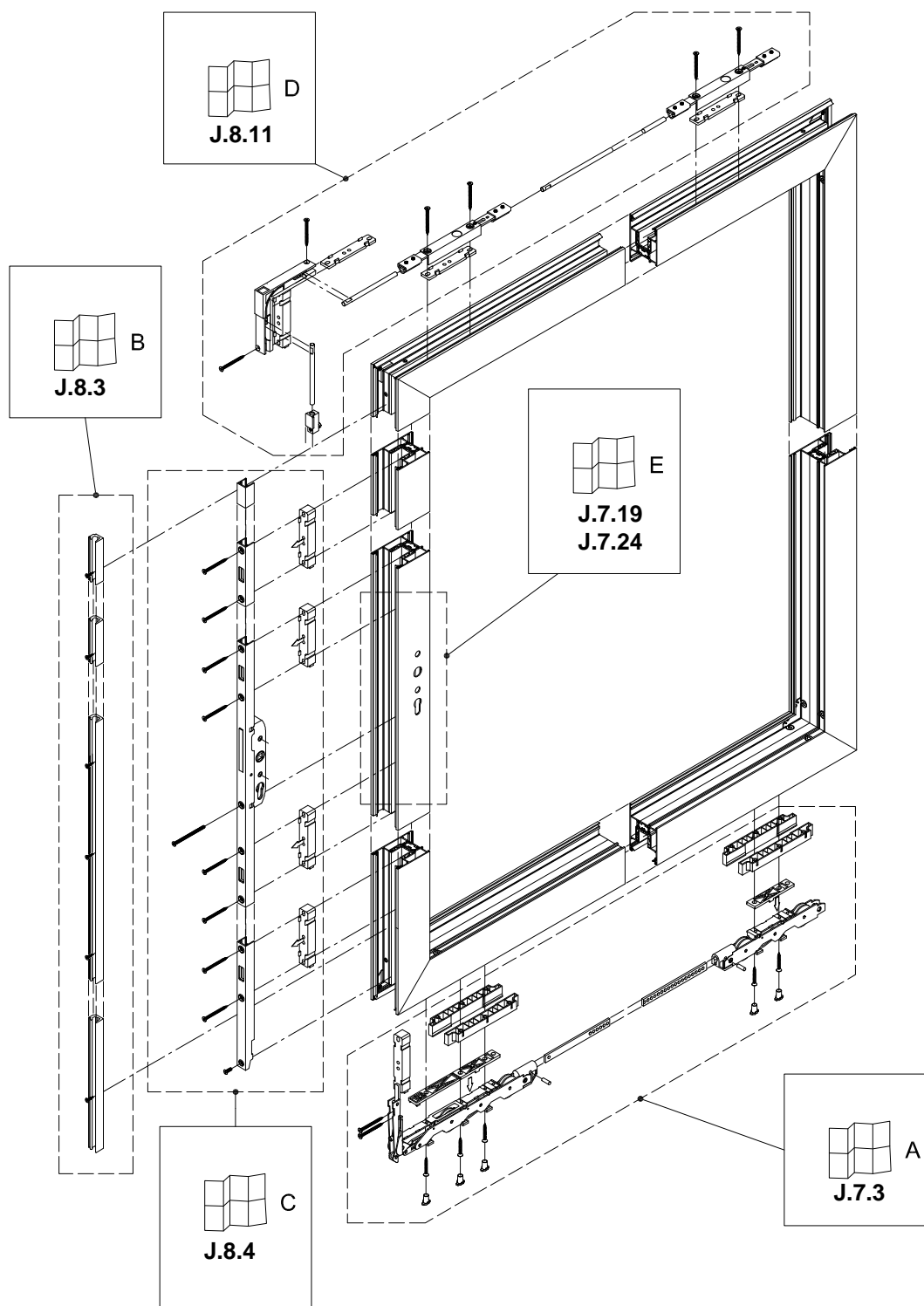
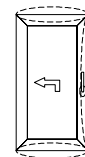
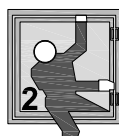

## ASSEMBLAGGIO FERRAMENTA ANTA - RC2

### ASSEMBLAGGIO CO2206

1 / 15

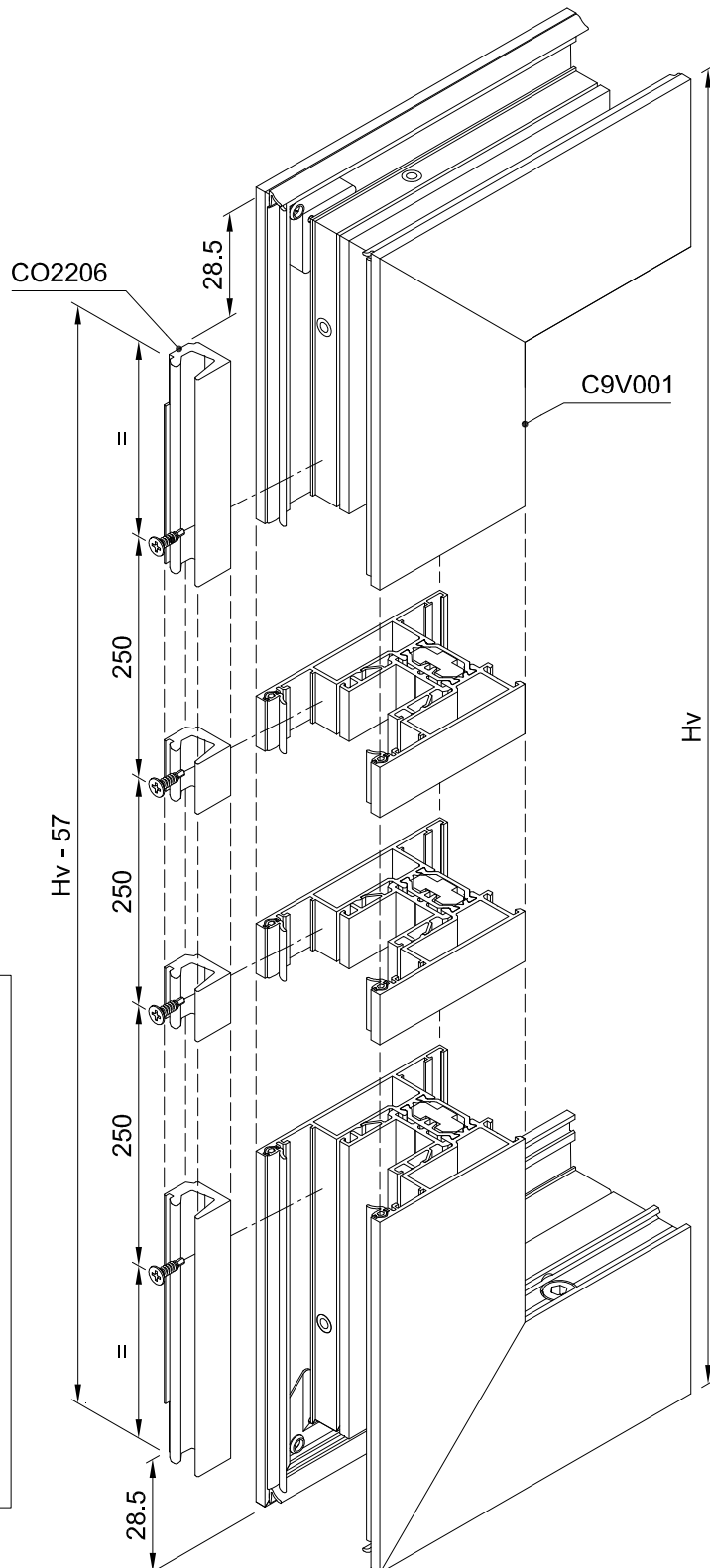
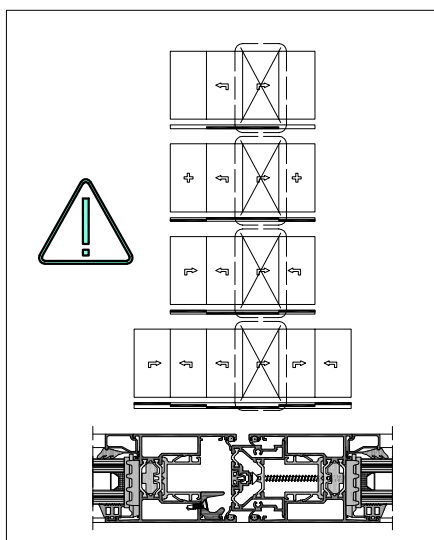
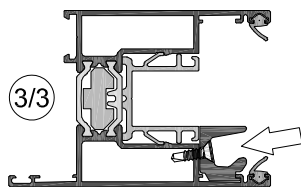
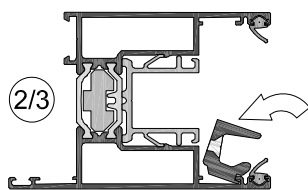
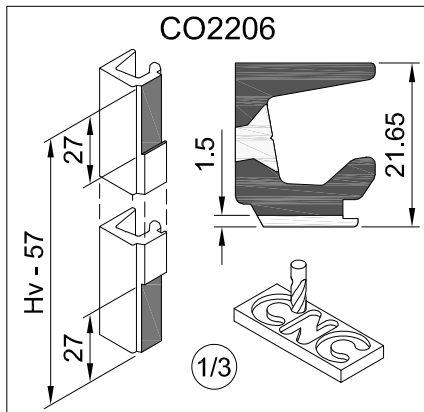
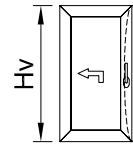

C160-ASS-2159L

PREPARAZIONE ZB0033/ZB0034/ZB0035/ZB0036

2 / 15

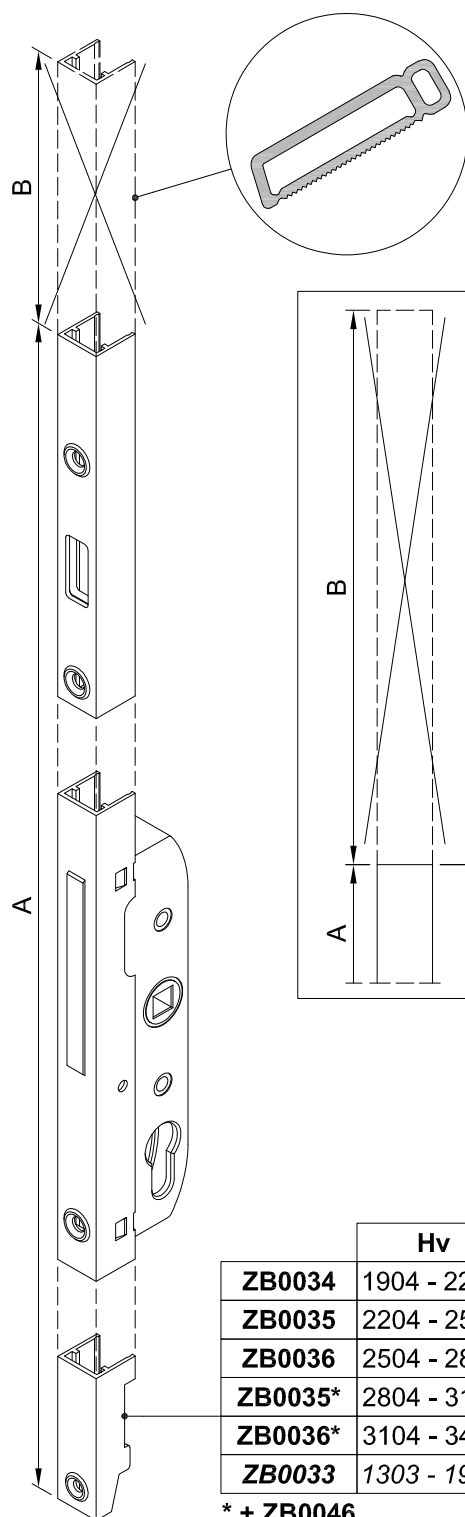
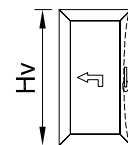
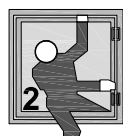

	Hv	A	B
ZB0034	1904 - 2203	Hv - 208	2098 - Hv
ZB0035	2204 - 2503		2398 - Hv
ZB0036	2504 - 2803		2698 - Hv
ZB0035*	2804 - 3103	Hv - 808	2998 - Hv
ZB0036*	3104 - 3403		3298 - Hv
ZB0033	1303 - 1903	Hv - 208	1798 - Hv

\* + ZB0046



## ASSEMBLAGGIO FERRAMENTA ANTA - RC2

### PREPARAZIONE CHIUSURA MECCANISMO ALZANTE-SCORREVOLE

3 / 15

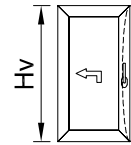

	Hv
<b>ZB0034</b>	1904 - 2203
<b>ZB0035</b>	2204 - 2503
<b>ZB0036</b>	2504 - 2803
<b>ZB0035*</b>	2804 - 3103
<b>ZB0036*</b>	3104 - 3403
<b>ZB0033</b>	1303 - 1903

\* + ZB0046

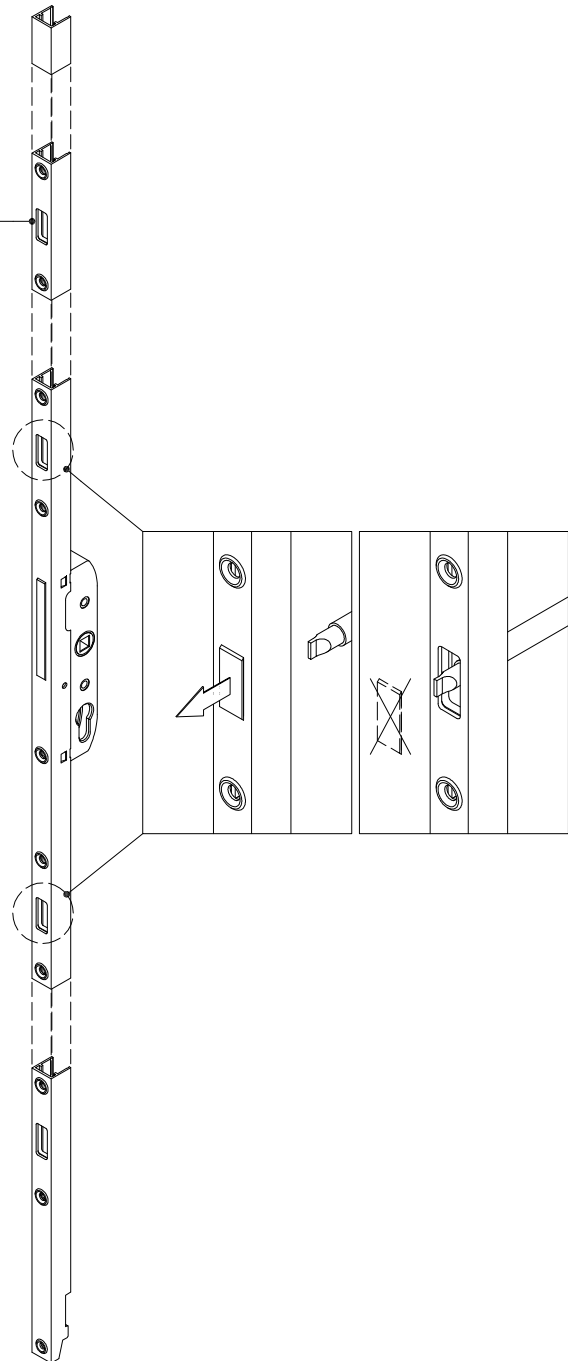

**ASSEMBLAGGIO FERRAMENTA ANTA - RC2**

**INSTALLAZIONE ZB0033/ZB0034/ZB0035/ZB0036 - OPZIONE SENZA MANIGLIA ESTERNA**

4 / 15

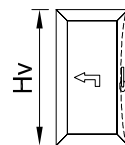
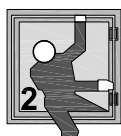

	Hv
ZB0034	1904 - 2203
ZB0035	2204 - 2503
ZB0036	2504 - 2803
ZB0035*	2804 - 3103
ZB0036*	3104 - 3403
ZB0033	1303 - 1903

\* + ZB0046

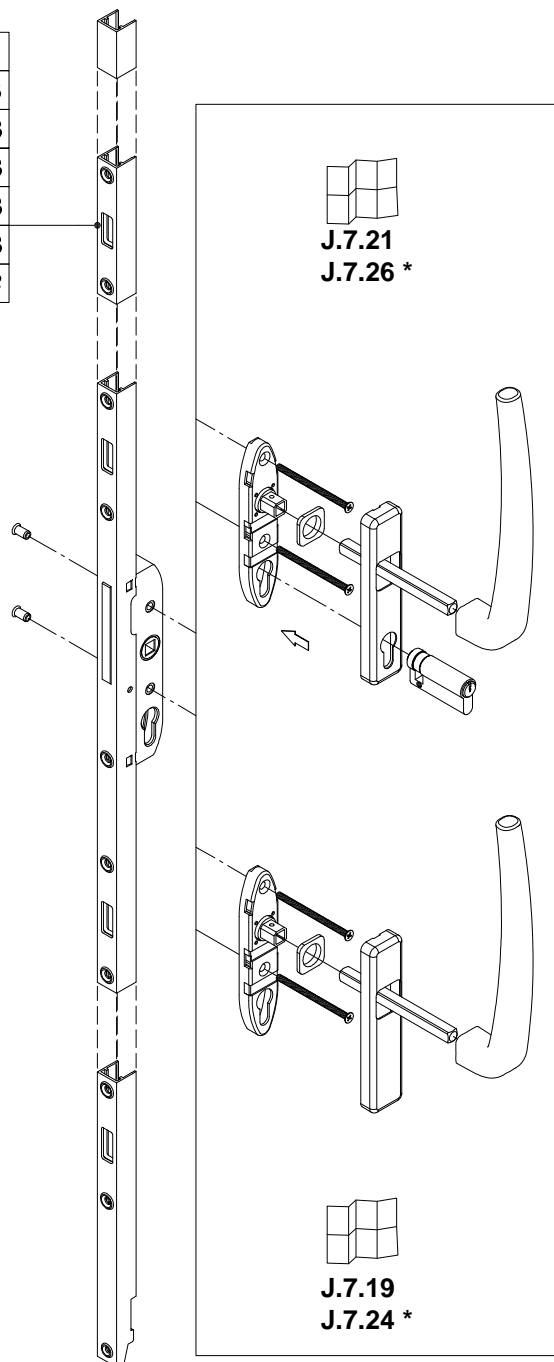
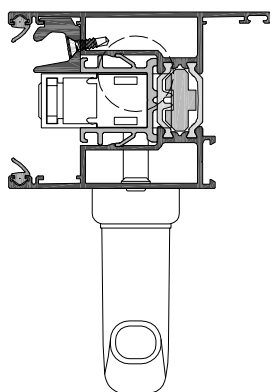
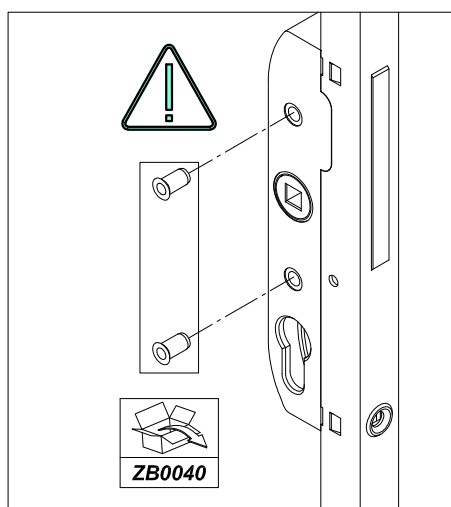

\* - S-LINE

## ASSEMBLAGGIO FERRAMENTA ANTA - RC2

### ASSEMBLAGGIO ZB0053/ZB0054 - OPTIONAL

5 / 15

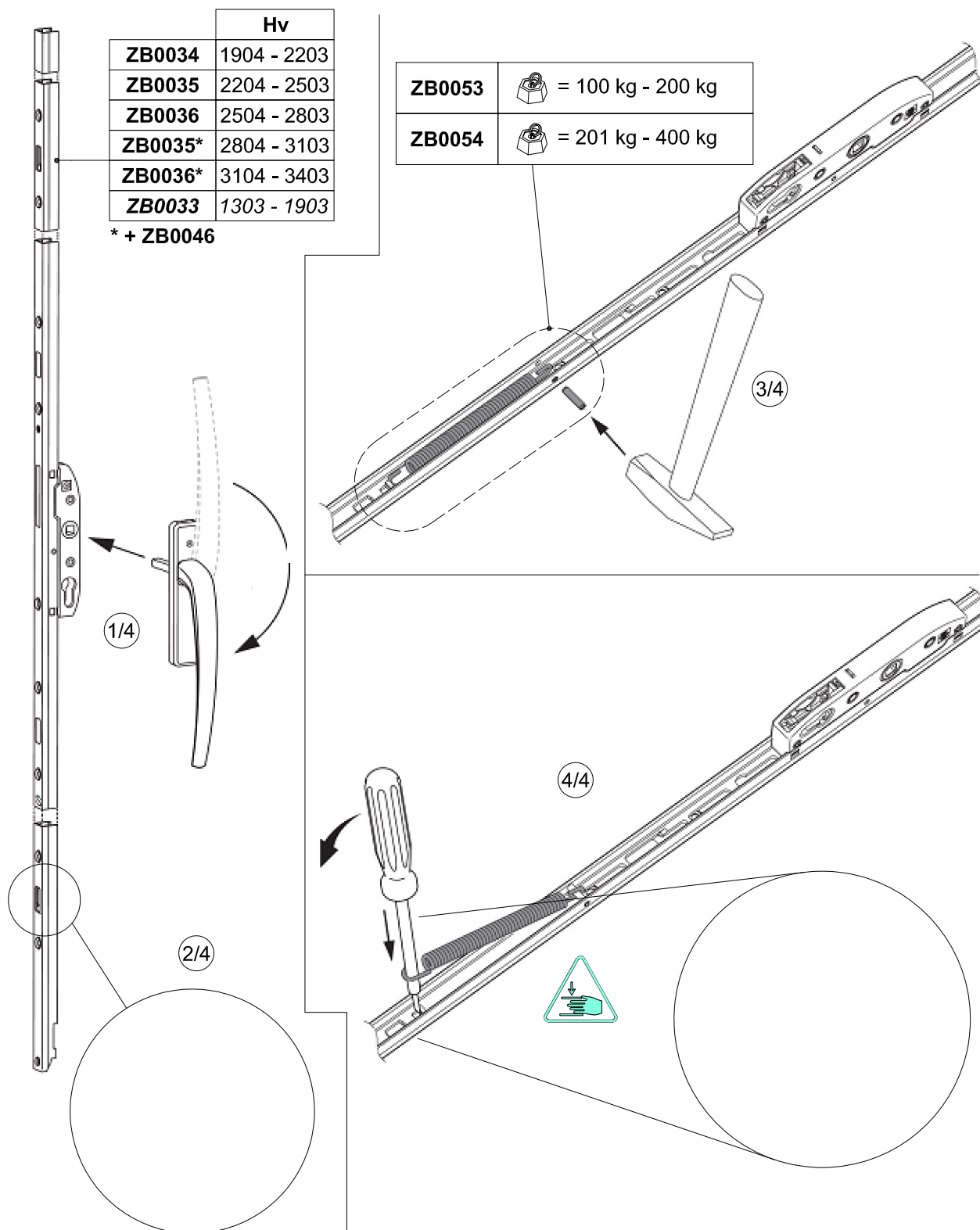
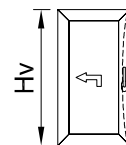
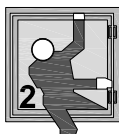

C160-ASS-2157L

**PREPARAZIONE ZB0046**

6 / 15

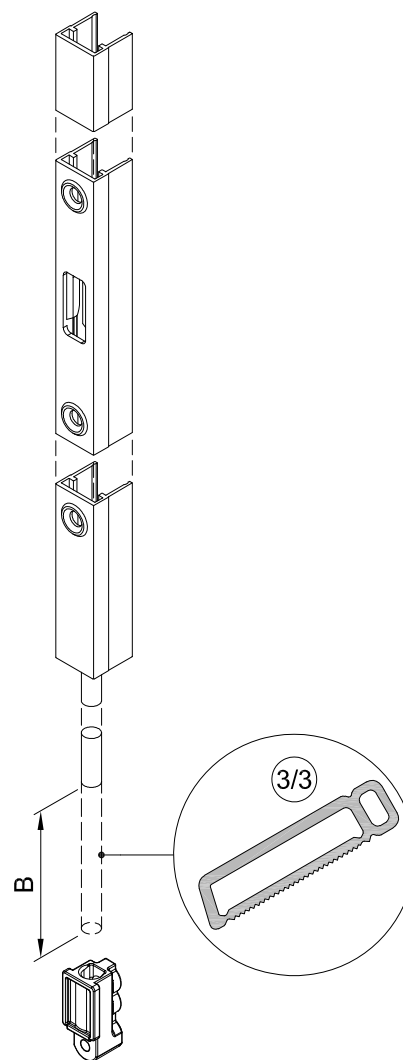
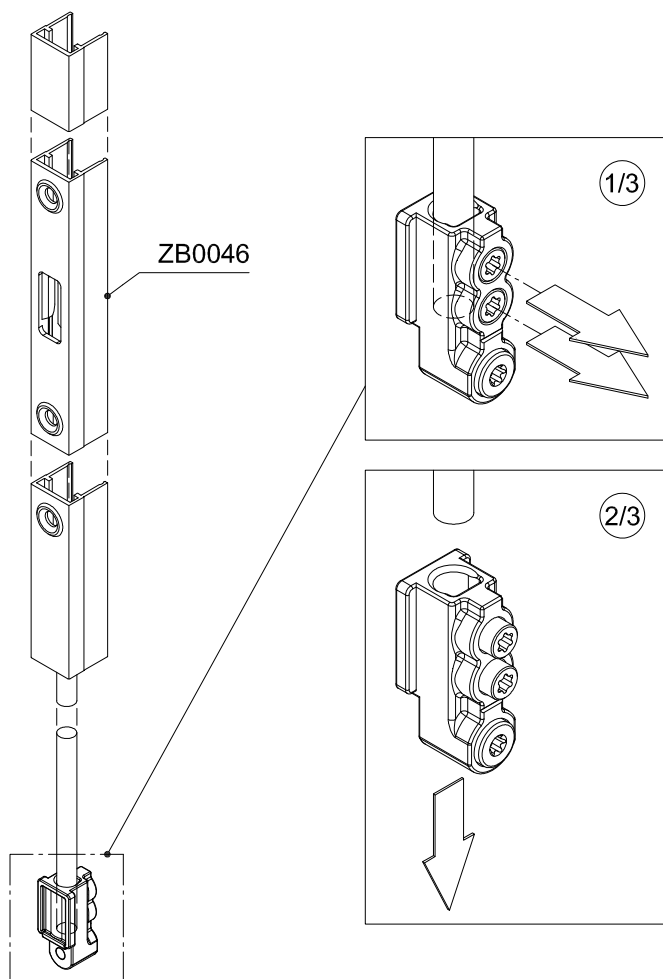
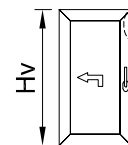
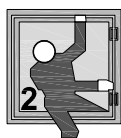

	Hv	B
ZB0035*	2804 - 3103	3077 - Hv
ZB0036*	3104 - 3403	3377 - Hv

\* + ZB0046

## ASSEMBLAGGIO FERRAMENTA ANTA - RC2

### ASSEMBLAGGIO ZB0035/ZB0036 CON ZB0046

7 / 15

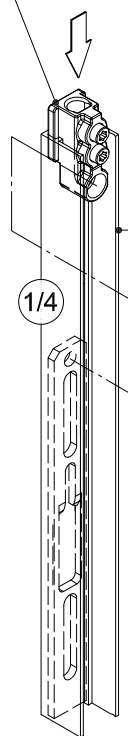
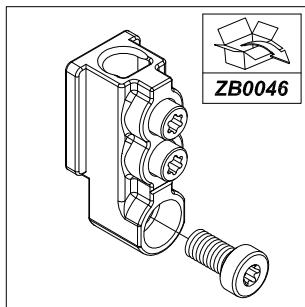
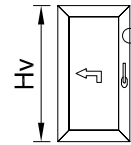

	Hv
ZB0035*	2804 - 3103
ZB0036*	3104 - 3403

\* + ZB0046

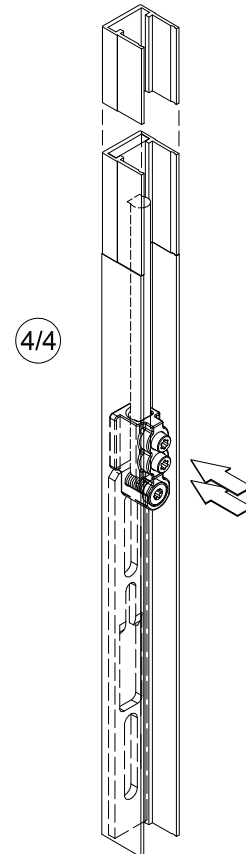
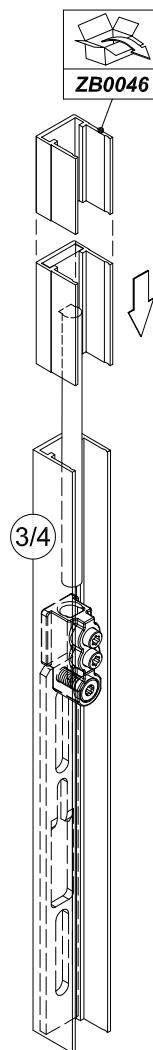
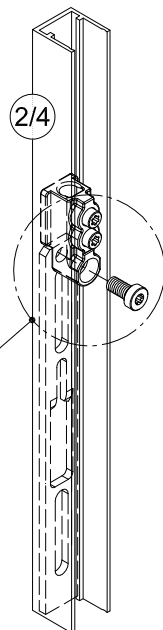
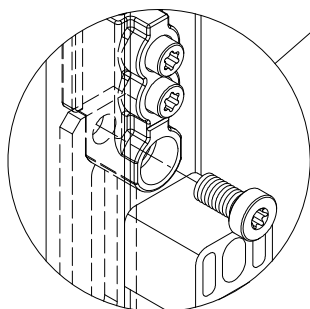

**ASSEMBLAGGIO FERRAMENTA ANTA - RC2**

**ASSEMBLAGGIO ZB0035/ZB0036/ZB0046 CON ZB0048 E ZB0049/ZB0050**

8 / 15

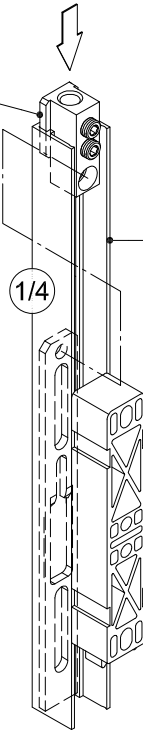
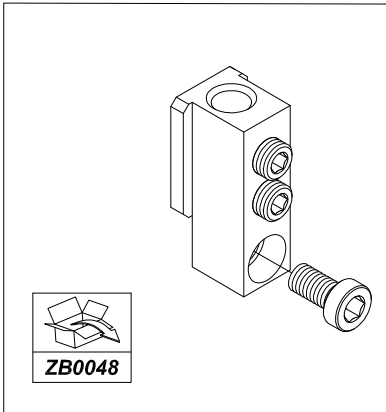
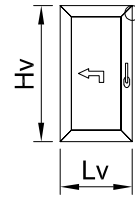

	Hv
<b>ZB0034</b>	1904 - 2203
<b>ZB0035</b>	2204 - 2503
<b>ZB0036</b>	2504 - 2803
<b>ZB0035*</b>	2804 - 3103
<b>ZB0036*</b>	3104 - 3403
<b>ZB0033</b>	1303 - 1903

\* + ZB0046

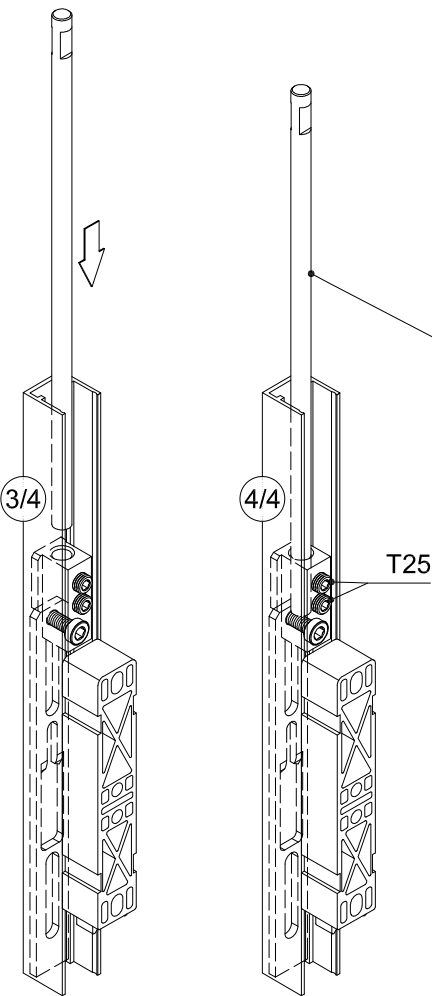
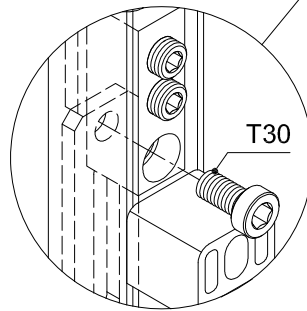

	Hv	C
<b>ZB0034</b>	1904 - 2203	Hv - 1803
<b>ZB0035</b>	2204 - 2503	Hv - 2103
<b>ZB0036</b>	2504 - 2803	Hv - 2403
<b>ZB0035*</b>	2804 - 3103	215 ??
<b>ZB0036*</b>	3104 - 3403	
<b>ZB0033</b>	1303 - 1903	Hv - 1503

\* + ZB0046

$Hv + Lv \leq 5258$	<b>ZB0049 (a)</b>
$Hv + Lv > 5258$	<b>ZB0050 (a)</b>

ZB0049/ZB0050 (b)

## ASSEMBLAGGIO FERRAMENTA ANTA - RC2

### ASSEMBLAGGIO ZB0048 CON ZB0049/ZB0050

9 / 15

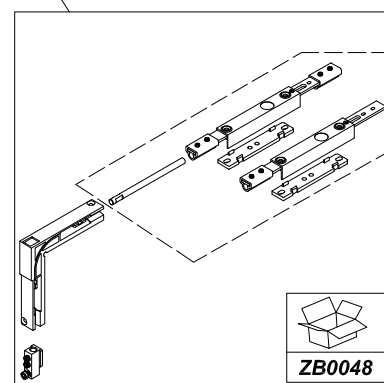
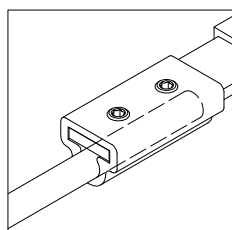
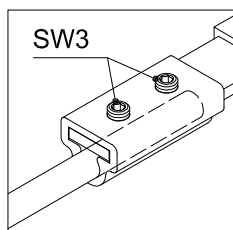
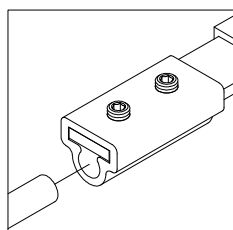
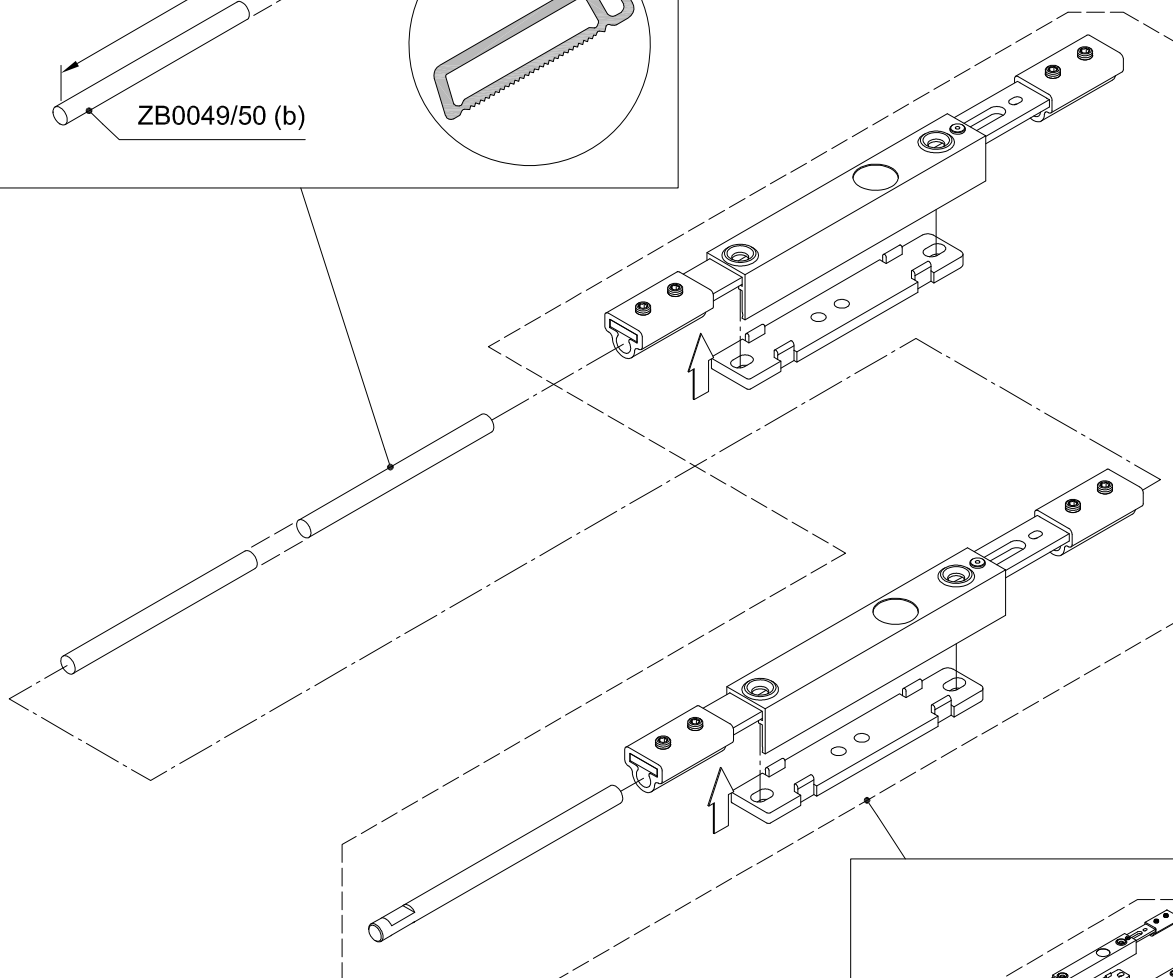
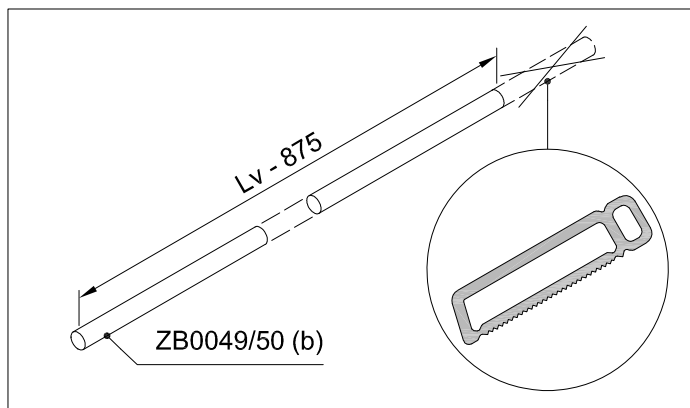
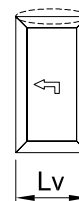
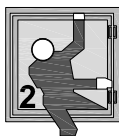





## ASSEMBLAGGIO FERRAMENTA ANTA - RC2

### INSTALLAZIONE CHIUSURA MECCANISMO ALZANTE-SCORREVOLE

11 / 15

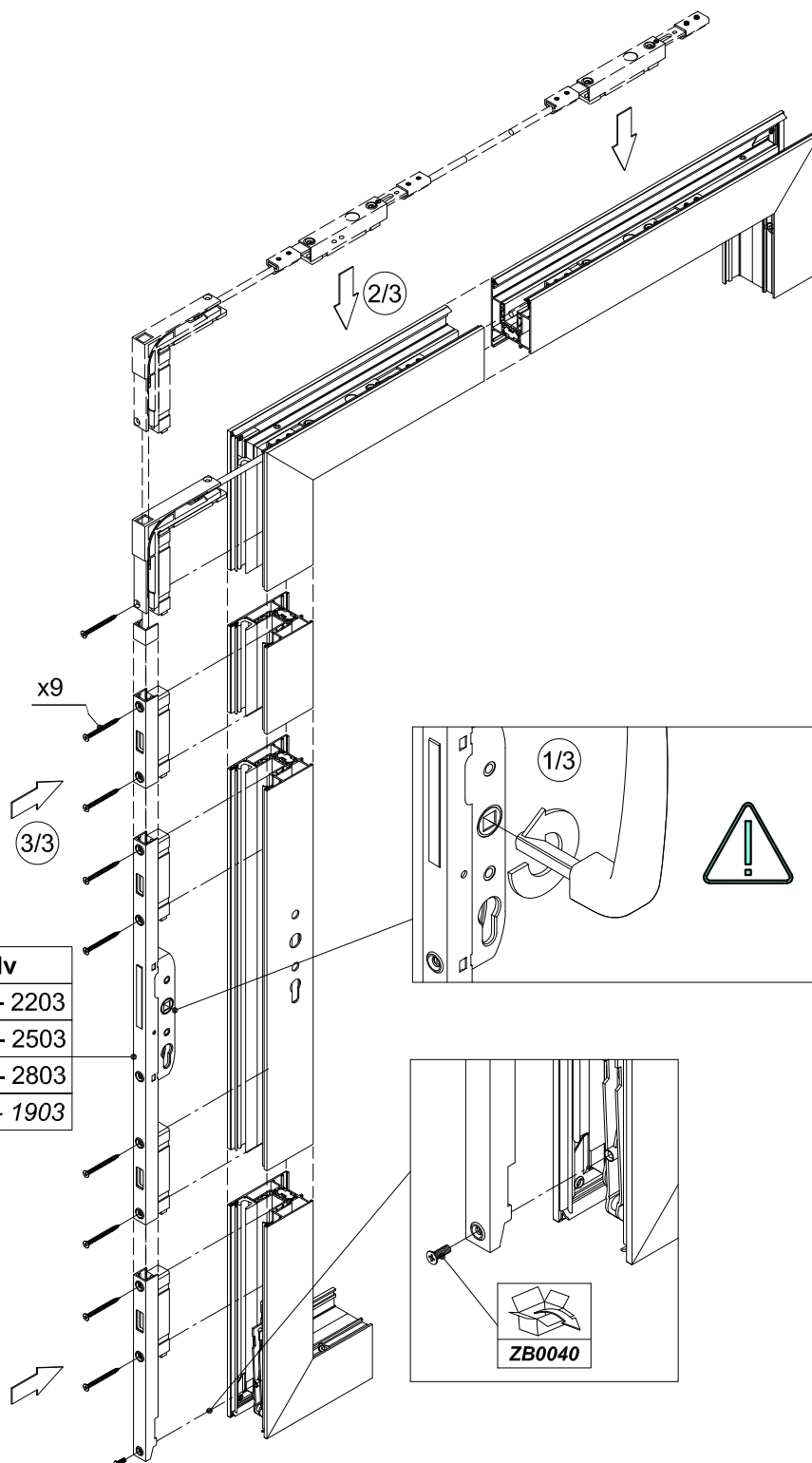
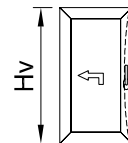
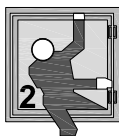

	Hv
ZB0034	1904 - 2203
ZB0035	2204 - 2503
ZB0036	2504 - 2803
ZB0033	1303 - 1903

\* + ZB0046

INSTALLAZIONE CHIUSURA MECCANISMO ALZANTE-SCORREVOLE

12 / 15

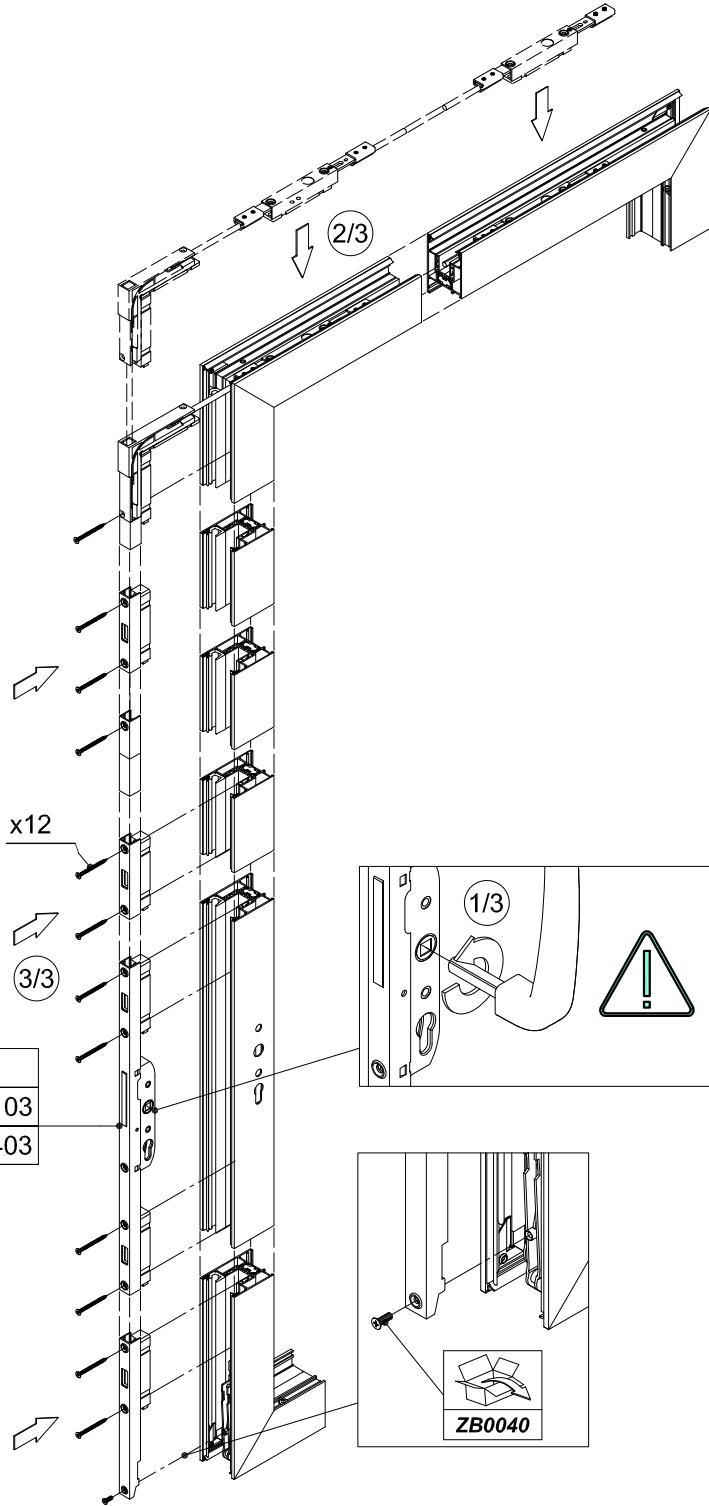
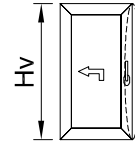

x12

3/3

	Hv
ZB0035*	2804 - 3103
ZB0036*	3104 - 3403

\* + ZB0046

## ASSEMBLAGGIO FERRAMENTA ANTA - RC2

### INSTALLAZIONE CHIUSURA MECCANISMO ALZANTE-SCORREVOLE - ANTA PASSIVA SCHEMA 4 ANTE

13 / 15

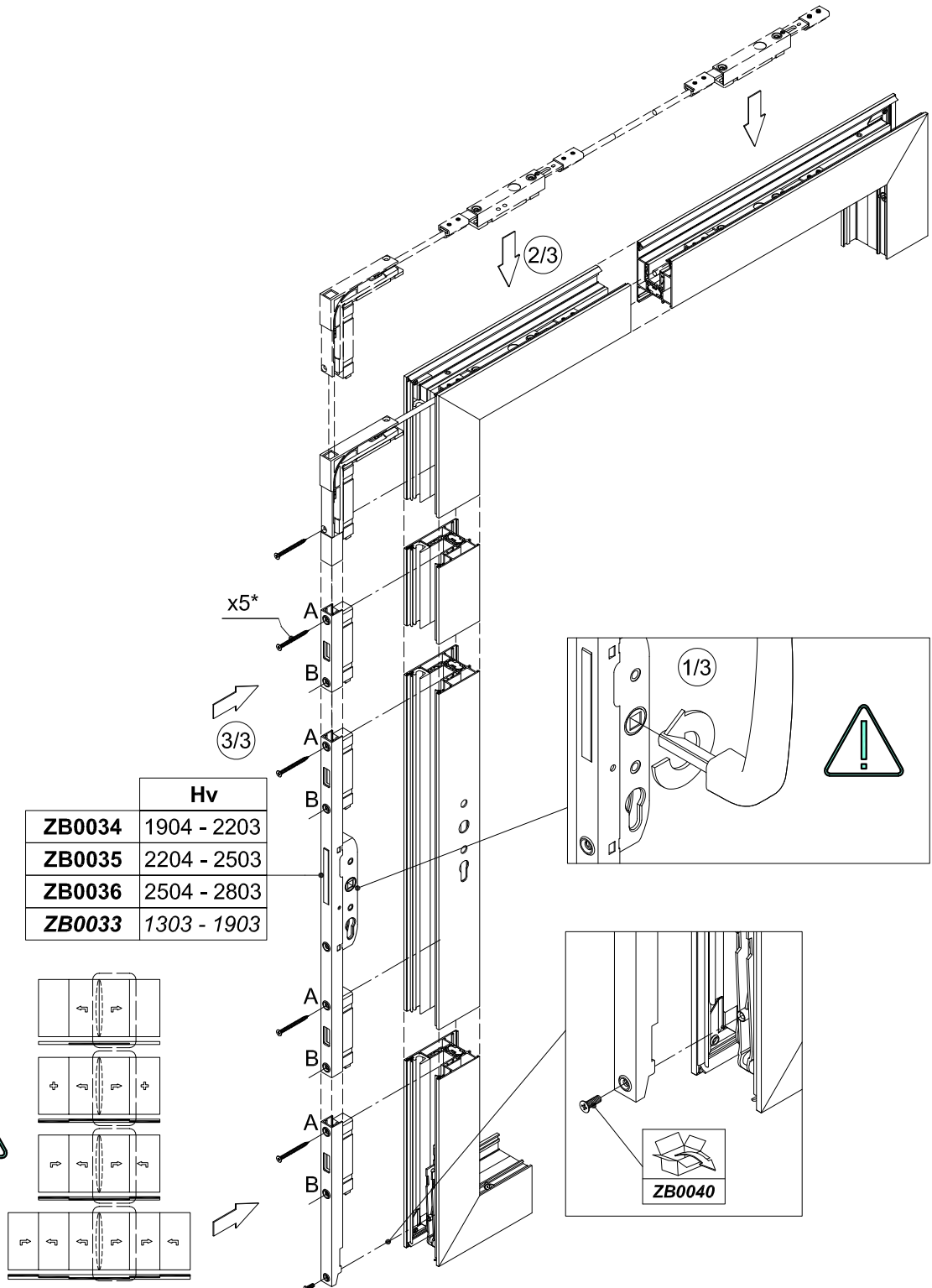
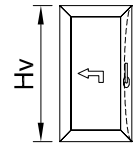

**INSTALLAZIONE CHIUSURA MECCANISMO ALZANTE-SCORREVOLE - ANTA PASSIVA SCHEMA 4 ANTE**

14 / 15

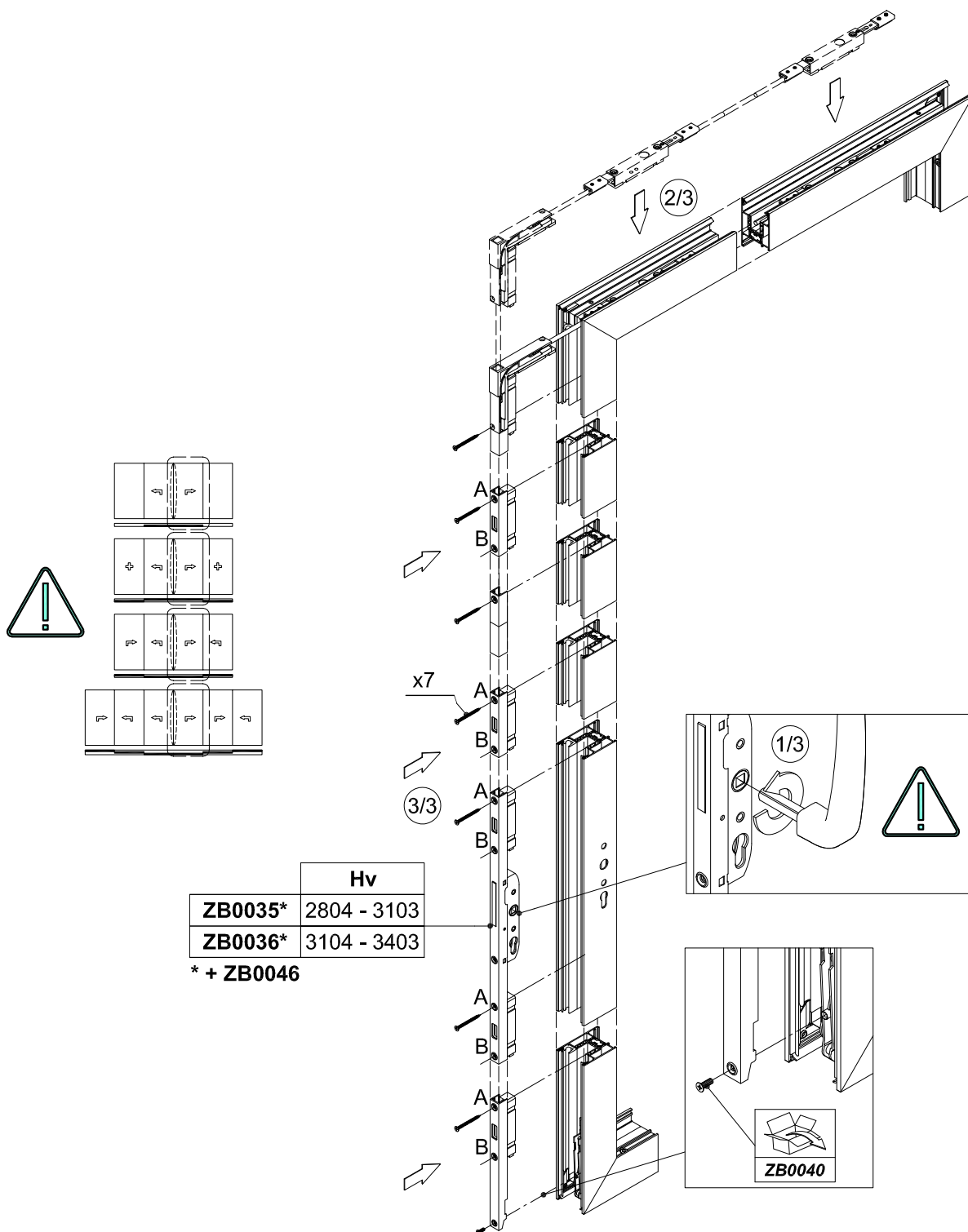
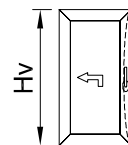
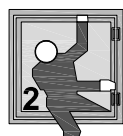

## ASSEMBLAGGIO FERRAMENTA ANTA - RC2

### INSTALLAZIONE CHIUSURA MECCANISMO ALZANTE-SCORREVOLE

15 / 15

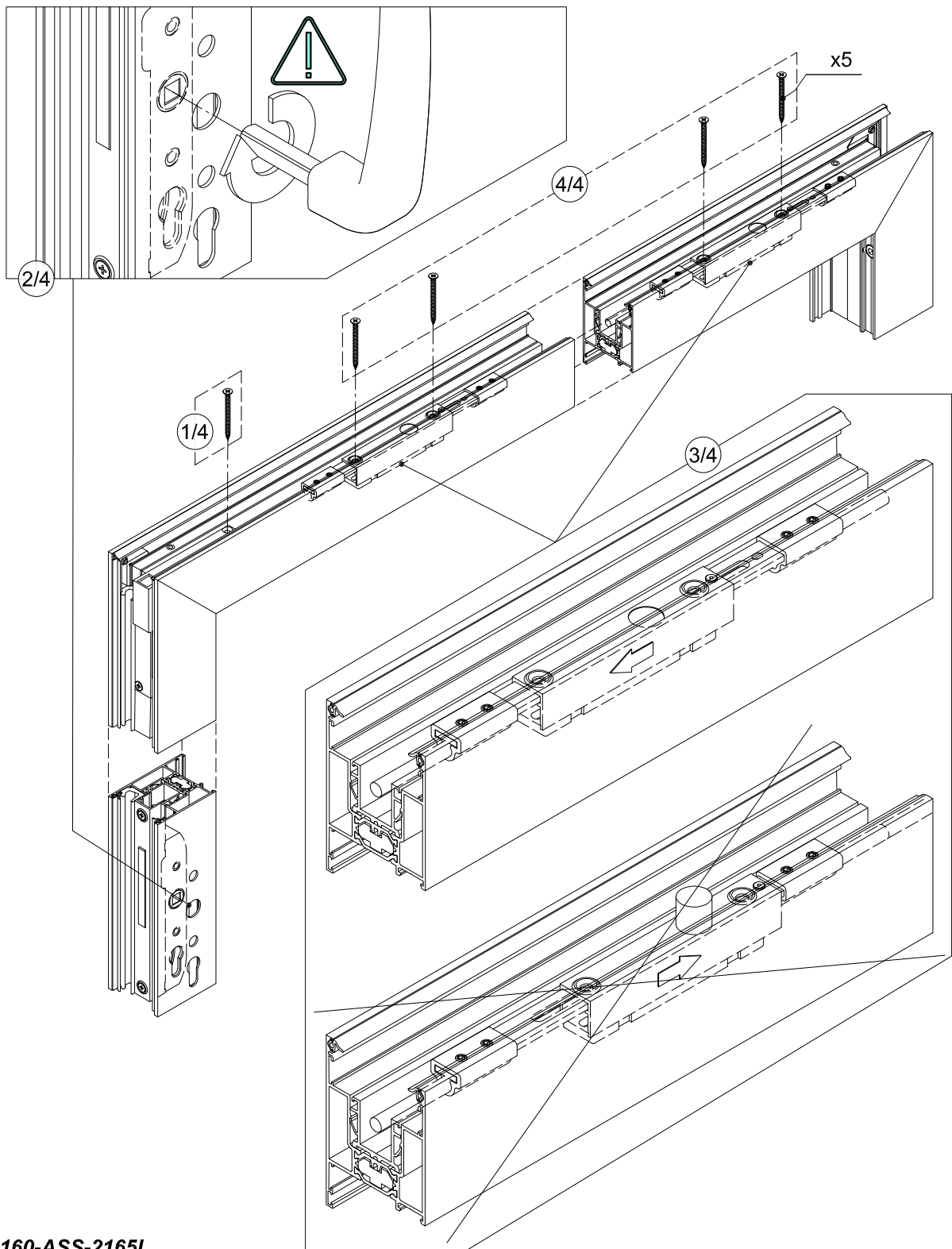
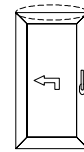

 C160-ASS-2165L



### **CONTENUTO**

Rinforzo anta - optional.....	J.10.1
Contenuto.....	J.10.1
Installazione blocco supporto VS5132 e RU9094.....	J.10.2
Installazione C9C001.....	J.10.3
Lato ferramenta alzante-scorrevole - Installazione RU9094.....	J.10.4
Lato ferramenta alzante-scorrevole - preparazione C9C001.....	J.10.5
Lato ferramenta alzante-scorrevole - Installazione C9C001.....	J.10.6

**INSTALLAZIONE BLOCCO SUPPORTO VS5132 E RU9094**

1 / 2

-SHI-
-SI-
I

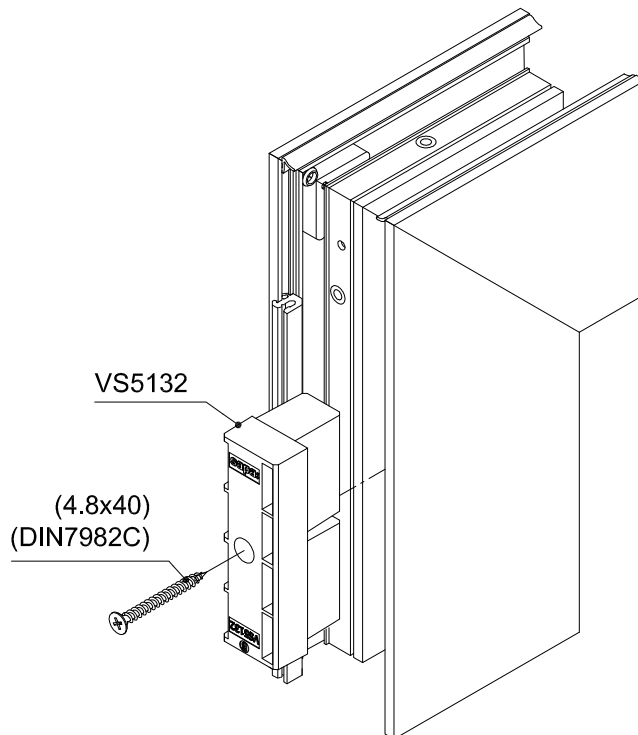
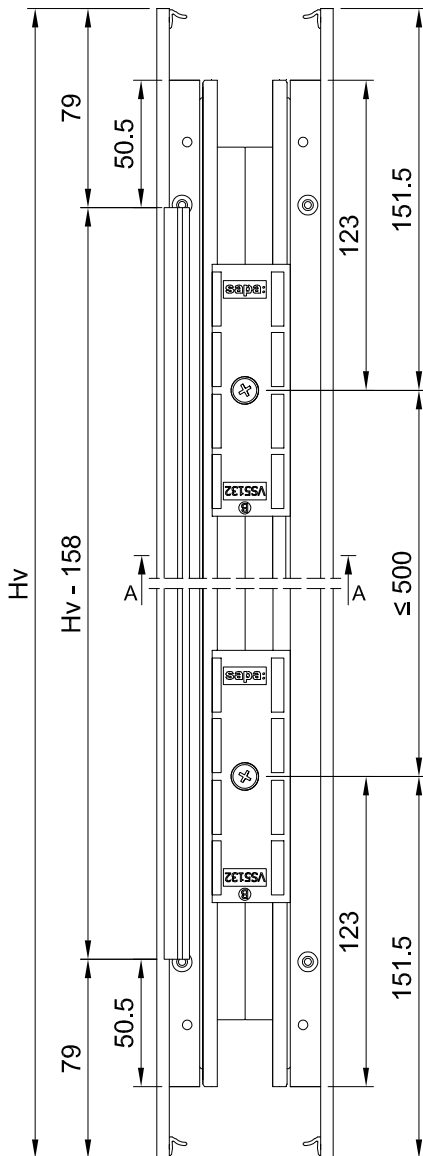
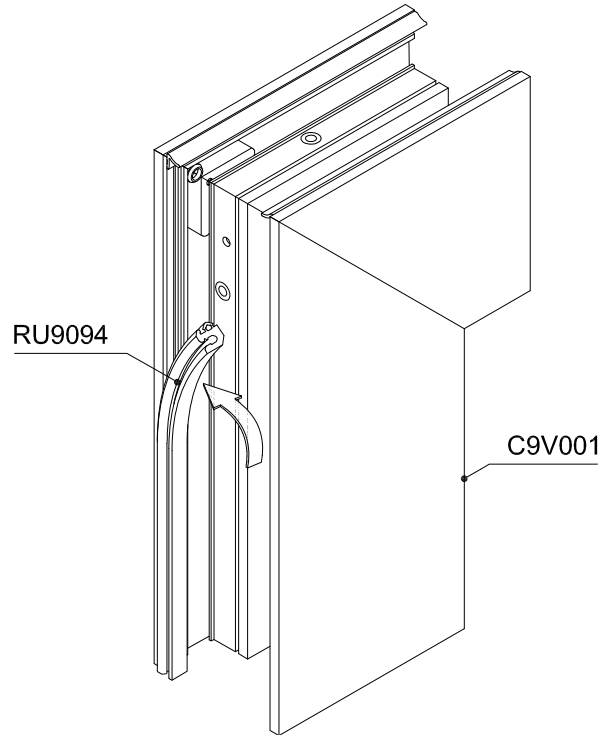
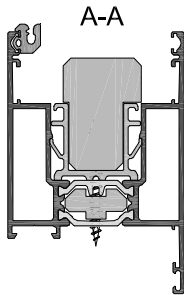
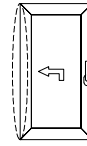

 **C160-ASS-2175L**



## RINFORZO ANTA - OPTIONAL

### INSTALLAZIONE C9C001

2 / 2

-SH-
-SI-
I

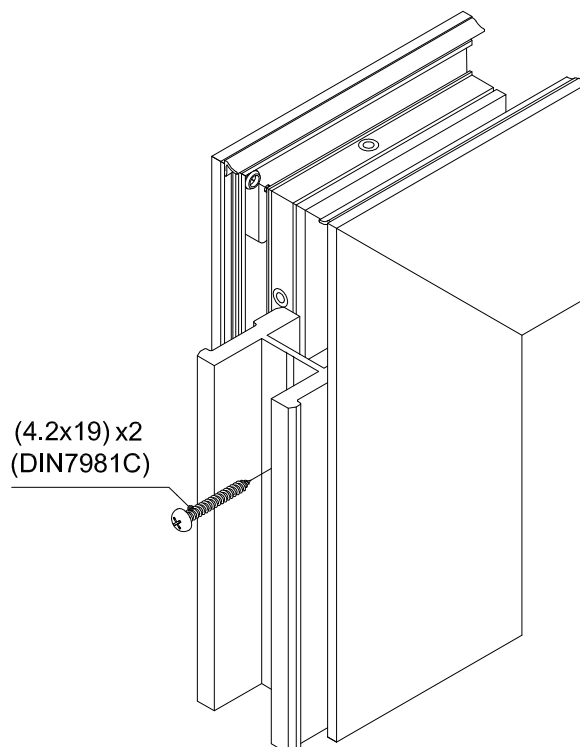
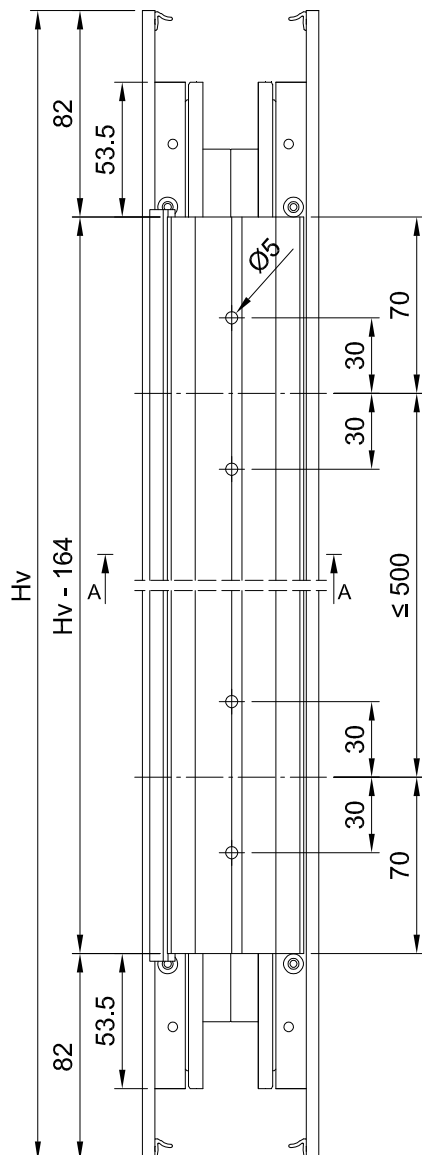
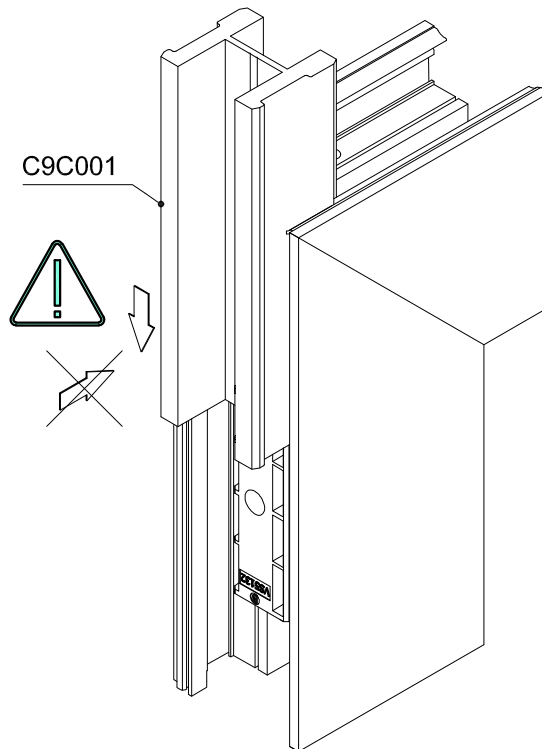
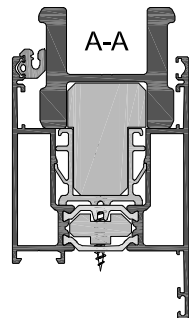
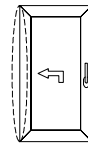

C160-ASS-2176L

**LATO FERRAMENTA ALZANTE-SCORREVOLE - INSTALLAZIONE RU9094**

1 / 3

-SHI-
-SI-
I

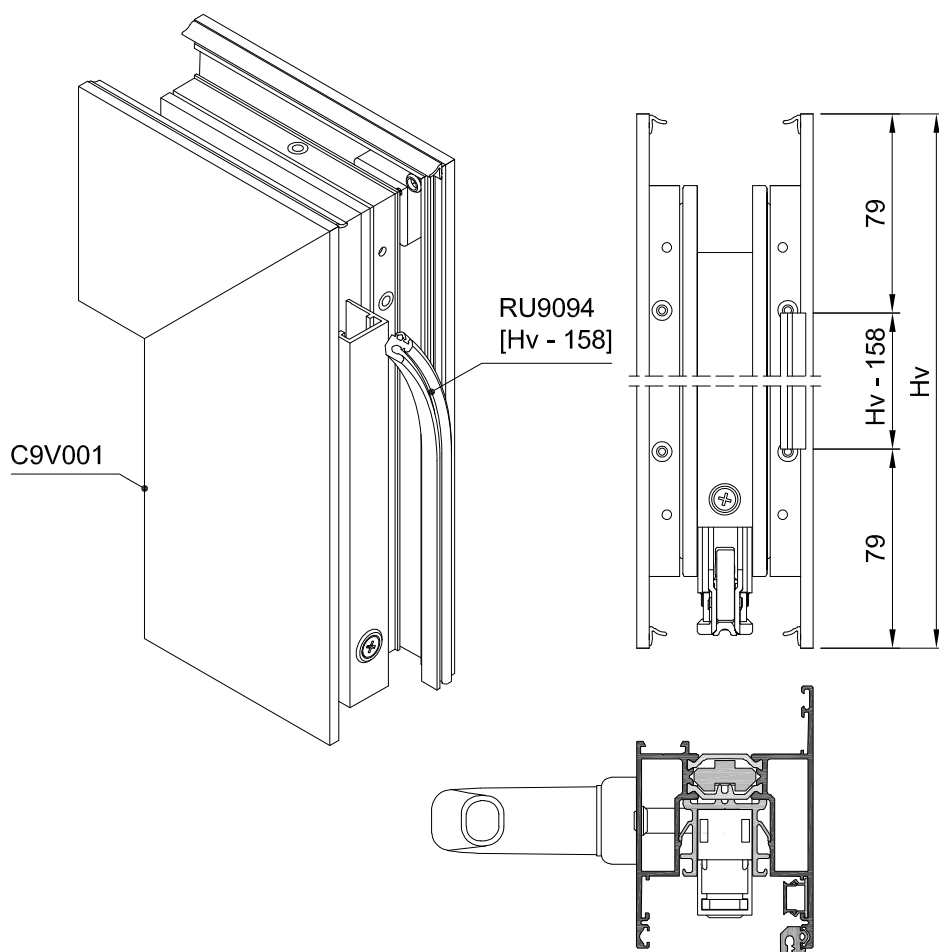
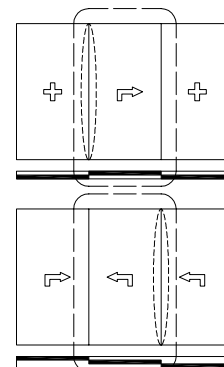
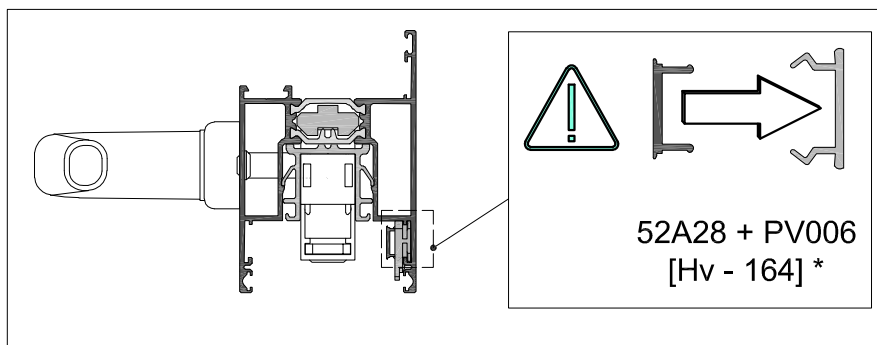
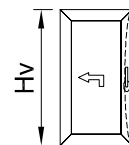

## RINFORZO ANTA - OPTIONAL

### LATO FERRAMENTA ALZANTE-SCORREVOLE - PREPARAZIONE C9C001

2 / 3

-SH-
-SI-
I

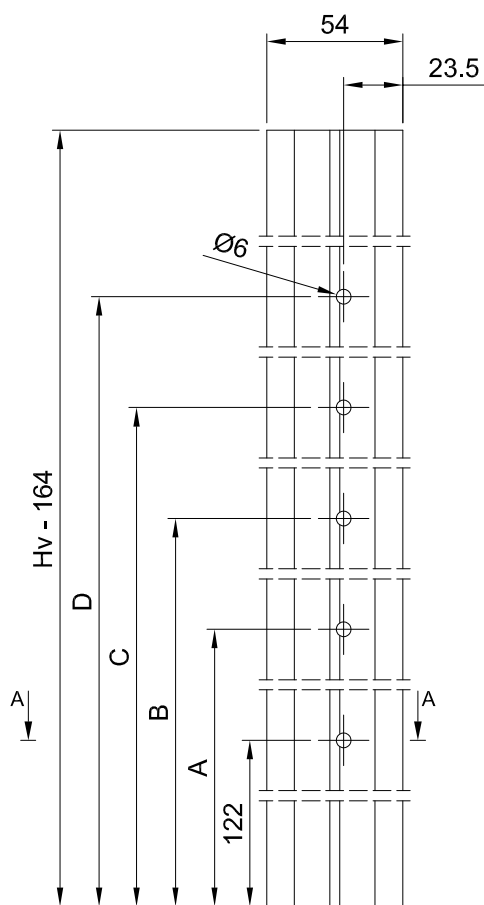
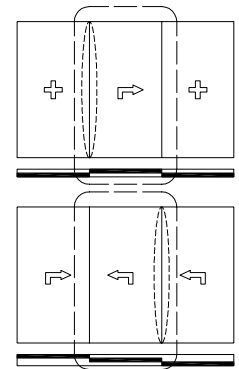
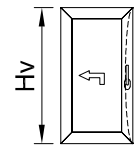

A-A

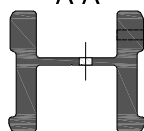

C9C001

	Hv	A	B	C	D	
<b>ZB0034</b>	1904 - 2203	622	1072	1472	/	
<b>ZB0035</b>	2204 - 2503			1772		
<b>ZB0036</b>	2504 - 2803			2072		
<b>ZB0035*</b>	2804 - 3103			1772		Hv - 407
<b>ZB0036*</b>	3104 - 3403			2072		
<b>ZB0033</b>	1303 - 1903	/	472	872	/	

\* + ZB0046

**LATO FERRAMENTA ALZANTE-SCORREVOLE - INSTALLAZIONE C9C001**

3 / 3

-SH-
-SI-
I

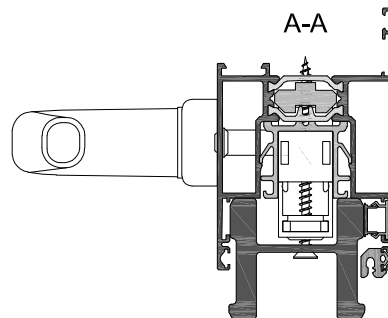
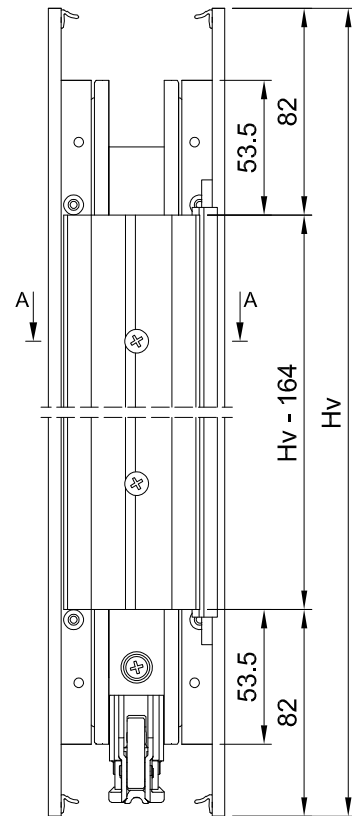
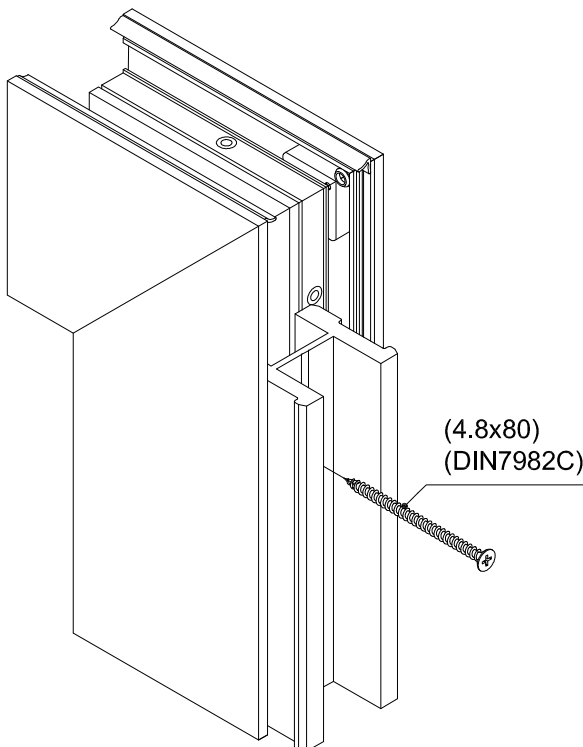
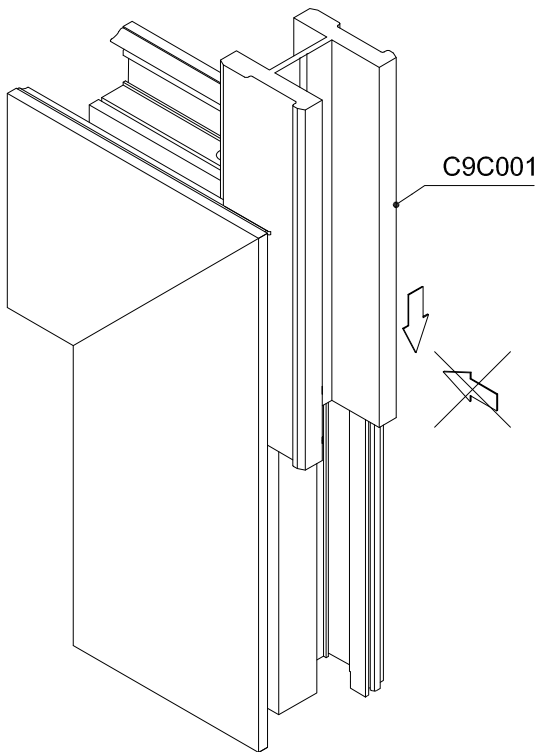
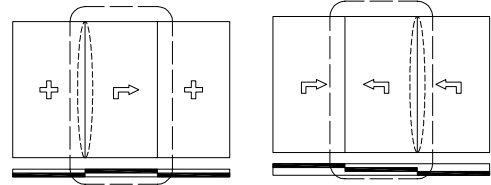
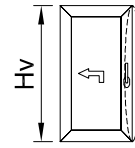

**CONTENUTO**

Assembly accessories vent .....	J.11.1
Contenuto .....	J.11.1
Assemblaggio distanziale VS5131 .....	J.11.2
Lavorazione profilato anta inserimento tappo terminali .....	J.11.3
Anta standard - installazione VS9149 e RU9094 .....	J.11.4
Anta standard - preparazione labirinto .....	J.11.5
Anta standard - assemblaggio labirinto .....	J.11.6
Anta standard - installazione BT6013 e C9A001/C9A002 .....	J.11.7
3-binari alzante-scorrevole lato ferramenta - assemblaggio VS9149 e RU9094 .....	J.11.8
3-binari alzante-scorrevole lato ferramenta - preparazione labirinto .....	J.11.9
3-binari alzante-scorrevole lato ferramenta - assemblaggio labirinto .....	J.11.10
3-binari alzante-scorrevole lato ferramenta - assemblaggio C9A001/C9A002 .....	J.11.11
Fisso-alzante-scorrevole-fissoi lato ferramenta - VS9211 e RU9094 .....	J.11.12
Fisso-alzante-scorrevole-fissoi lato ferramenta - labirinto .....	J.11.13
Fisso-alzante-scorrevole-fissoi lato ferramenta - assemblaggio labirinto .....	J.11.14
Fisso-alzante-scorrevole-fissoi lato ferramenta - assemblaggio C9A007 .....	J.11.15
Fisso-alzante-scorrevole-fissoi lato ferramenta - assemblaggio RU9009 .....	J.11.16
Fisso-alzante-scorrevole-fissoi lato ferramenta .....	J.11.17
Anta passiva schema 4 ante - preparazione RU0099 .....	J.11.22
Anta passiva schema 4 ante - preparazione C9C002 .....	J.11.23
Anta passiva schema 4 ante - installazione tappo sigillatura inferiore .....	J.11.26
Anta passiva schema 4 ante - Installazione punti di chiusura .....	J.11.27
Anta passiva schema 4 ante - installazione tappo sigillatura superiore .....	J.11.28

**ASSEMBLAGGIO DISTANZIALE VS5131**

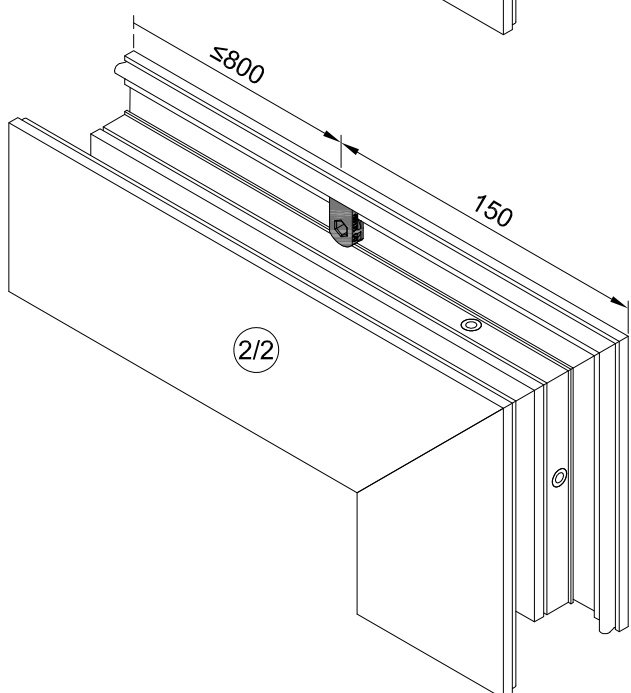
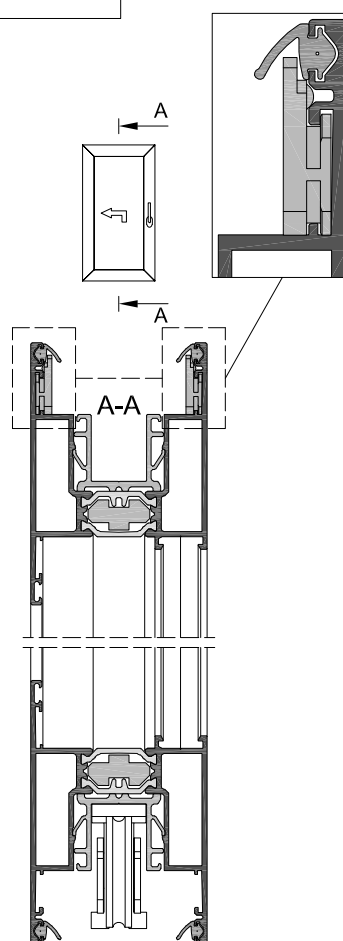
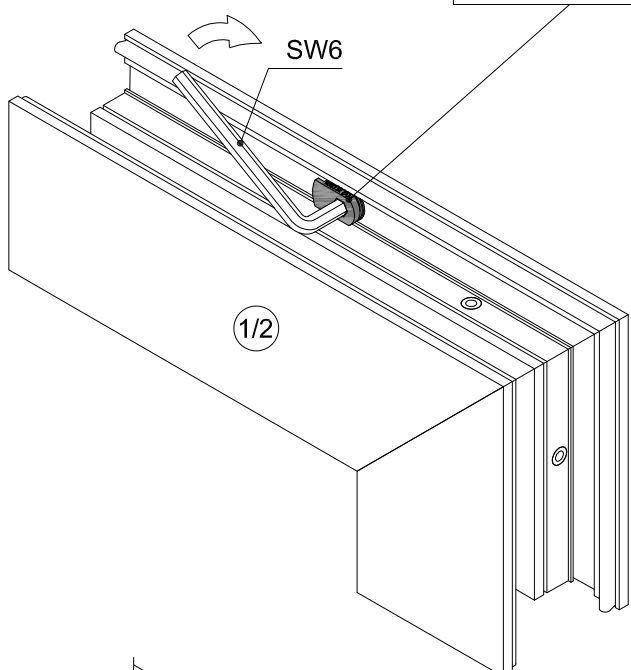
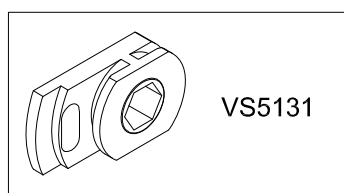
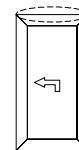

## ASSEMBLAGGIO ACCESSORI ANTA

### LAVORAZIONE PROFILATO ANTA INSERIMENTO TAPPO TERMINALI

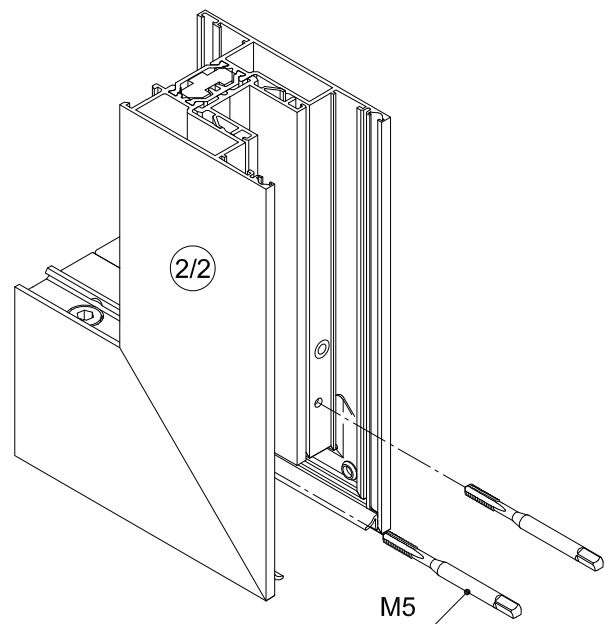
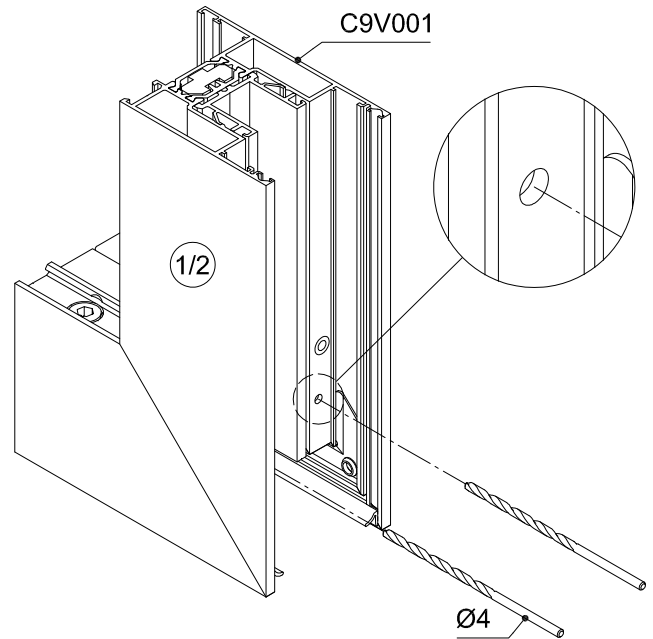
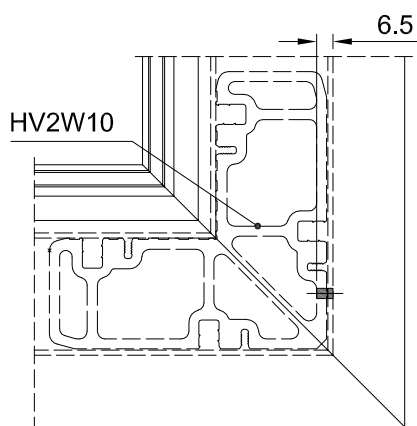
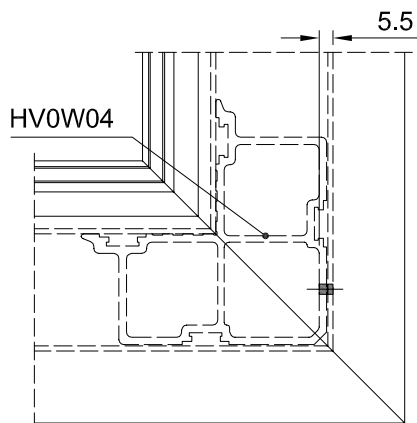
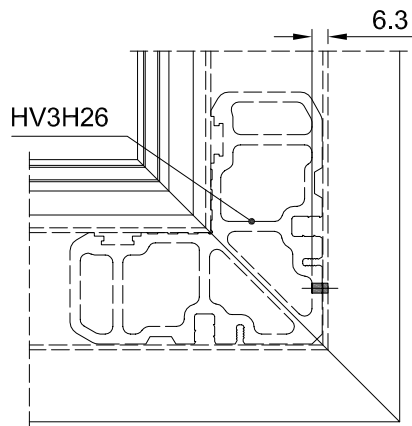
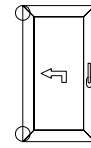

**ANTA STANDARD - INSTALLAZIONE VS9149 E RU9094**

1 / 4



J.10.3

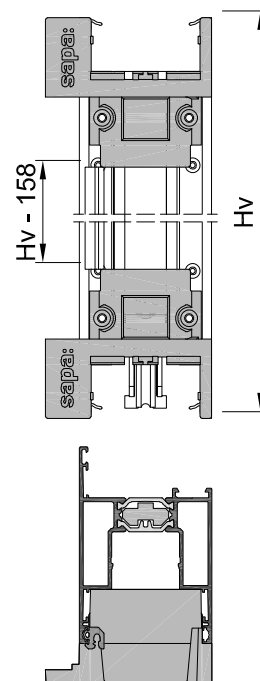
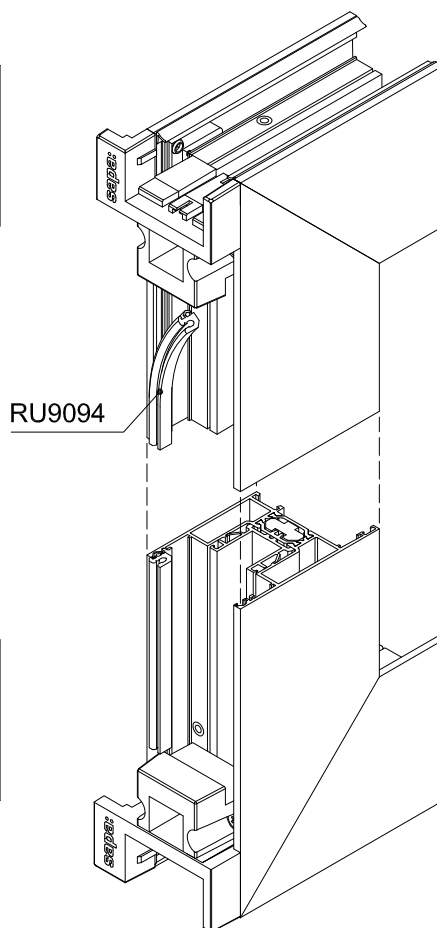
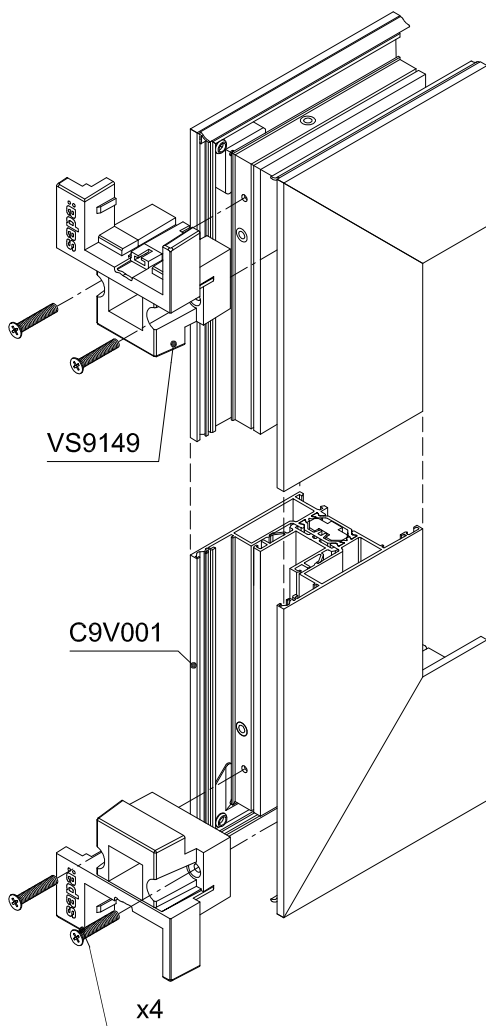
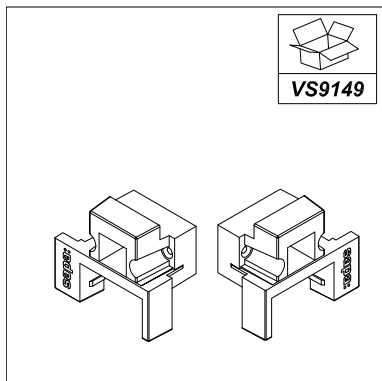
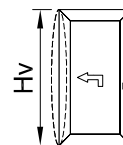



## ASSEMBLAGGIO ACCESSORI ANTA

### ANTA STANDARD - PREPARAZIONE LABIRINTO

2 / 4

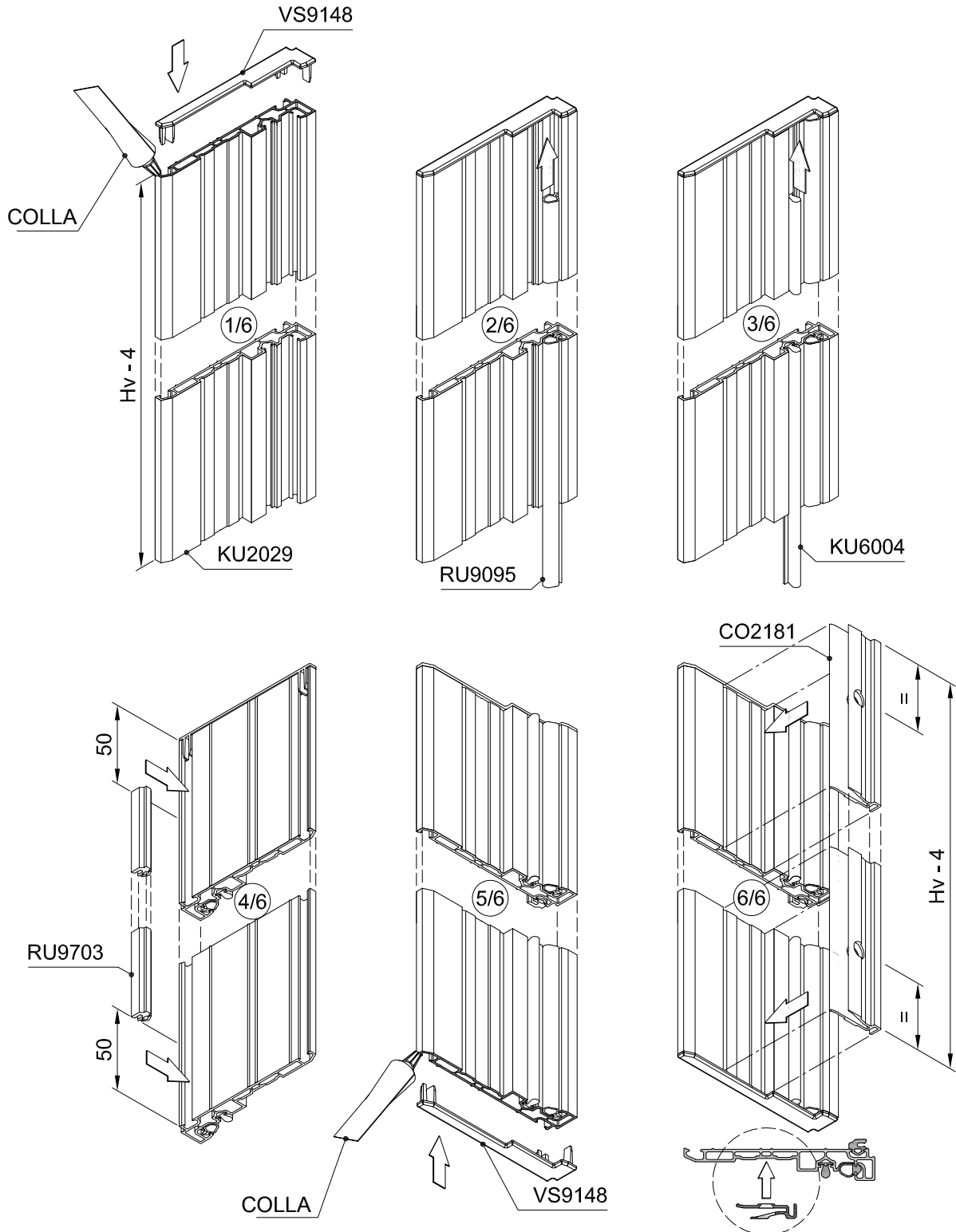
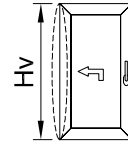

**ANTA STANDARD - ASSEMBLAGGIO LABIRINTO**

3 / 4

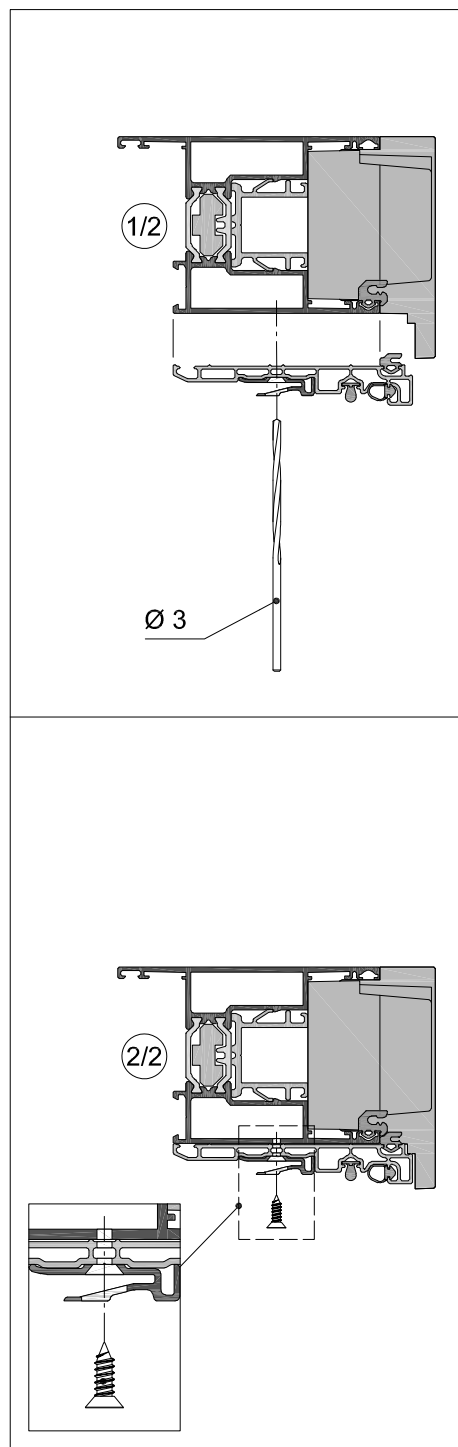
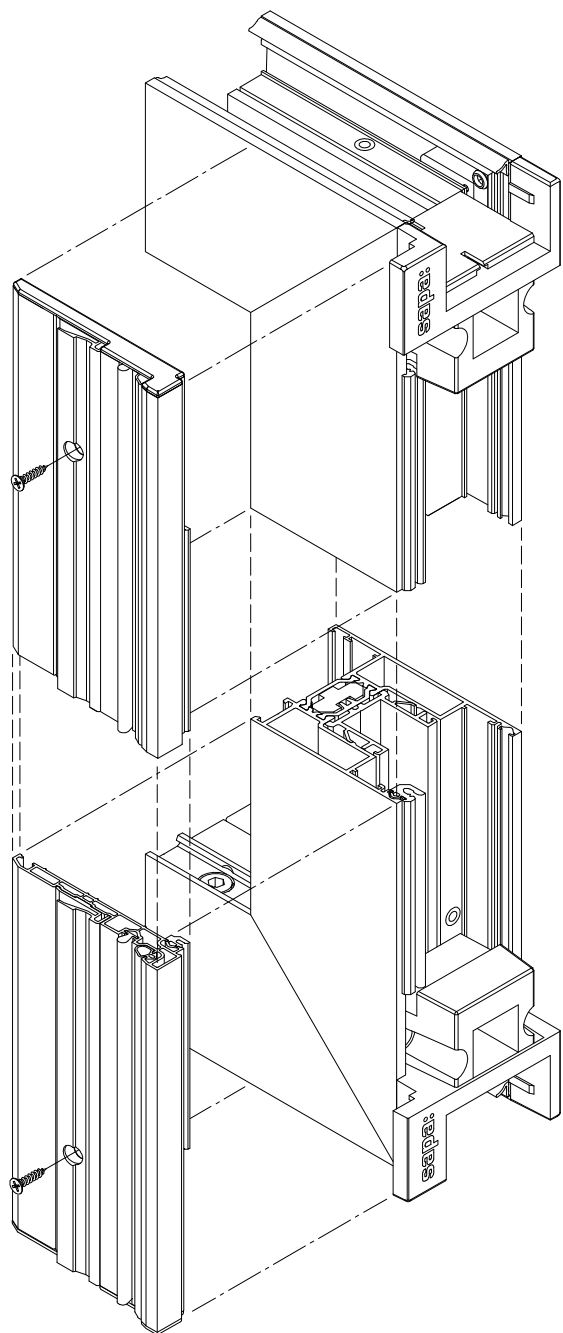
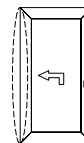

## ASSEMBLAGGIO ACCESSORI ANTA

### ANTA STANDARD - INSTALLAZIONE BT6013 E C9A001/C9A002

4 / 4

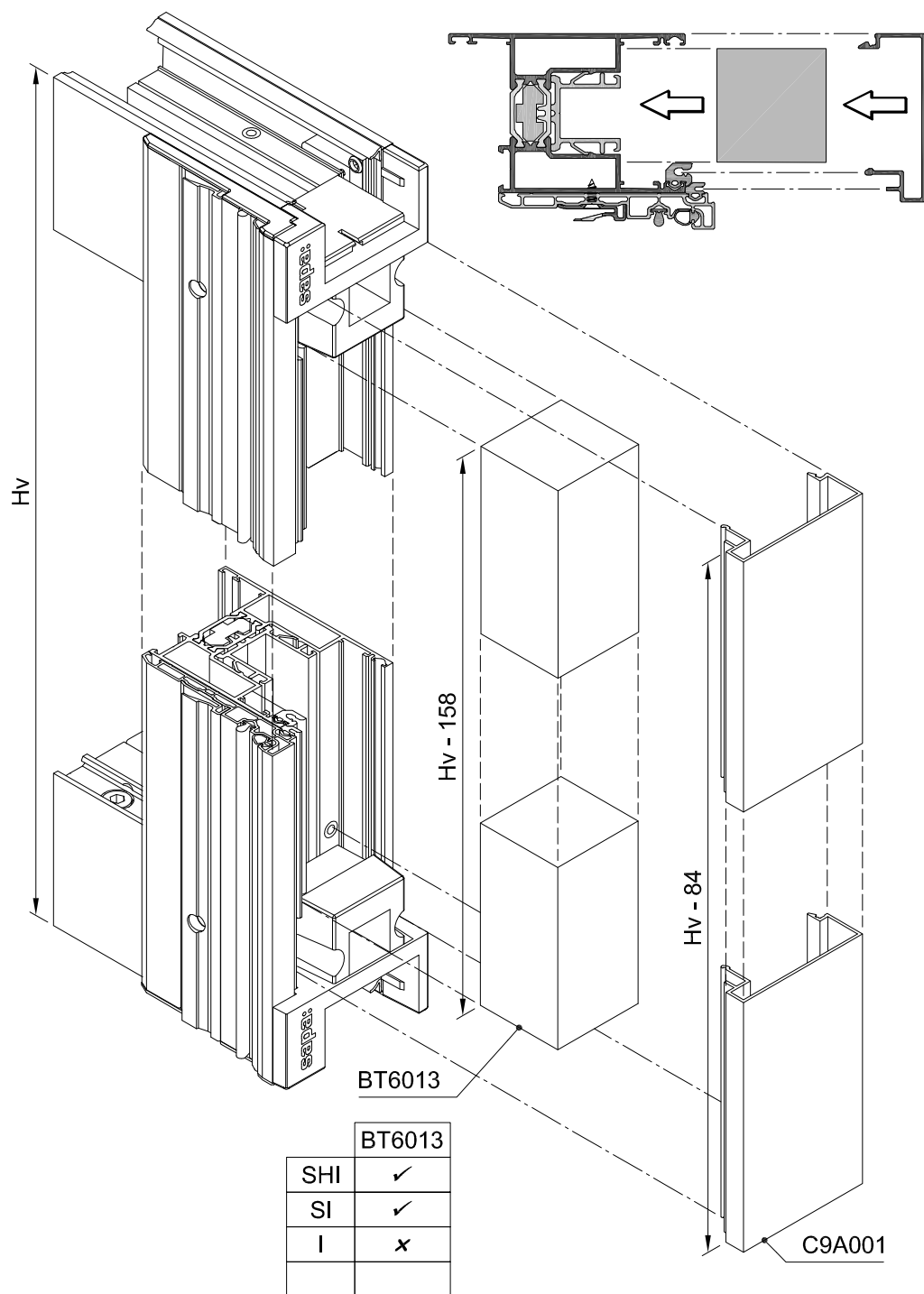
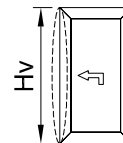

BT6013	
SHI	✓
SI	✓
I	x

**3-BINARI ALZANTE-SCORREVOLE LATO FERRAMENTA - ASSEMBLAGGIO VS9149 E RU9094**

1 / 4

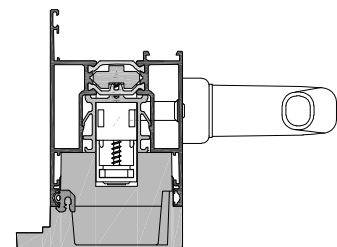
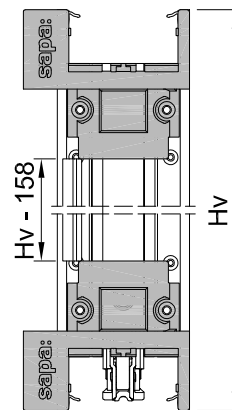
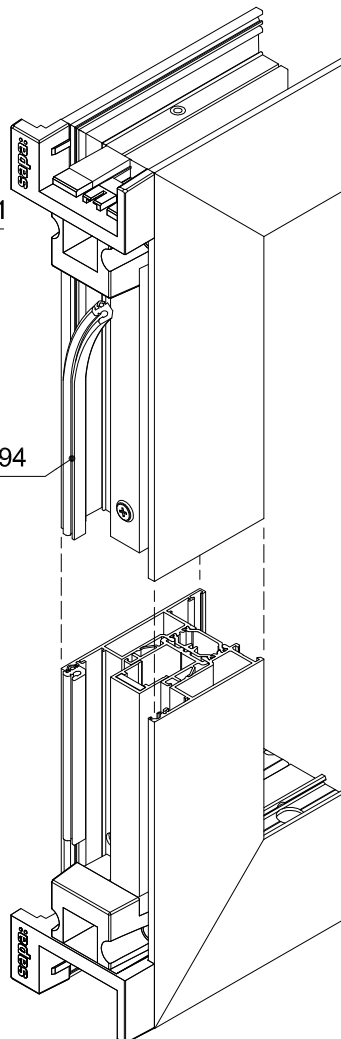
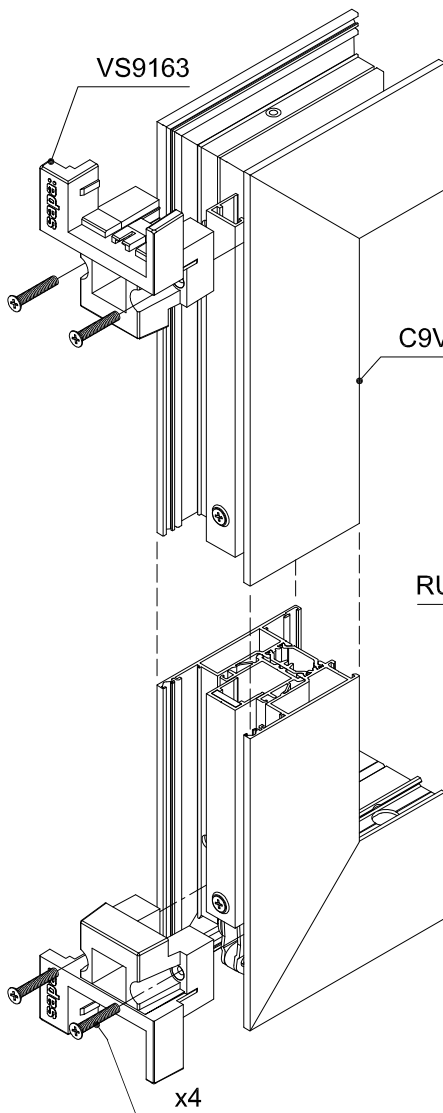
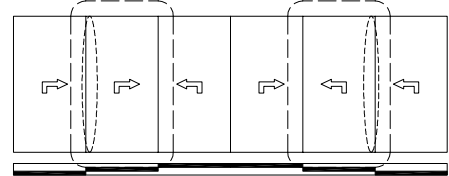
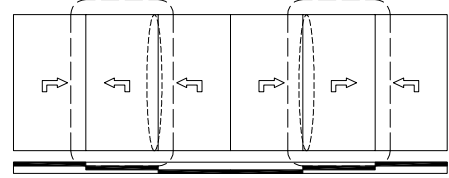
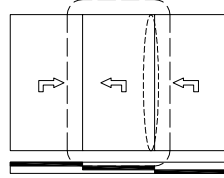
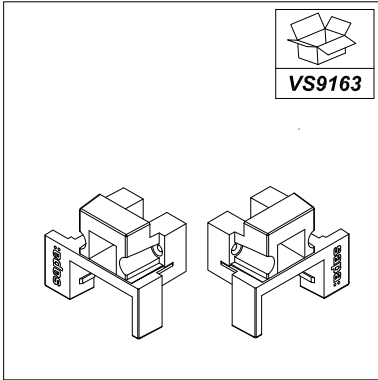
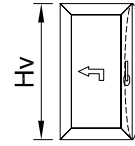

## ASSEMBLAGGIO ACCESSORI ANTA

### 3-BINARI ALZANTE-SCORREVOLE LATO FERRAMENTA - PREPARAZIONE LABIRINTO

2 / 4

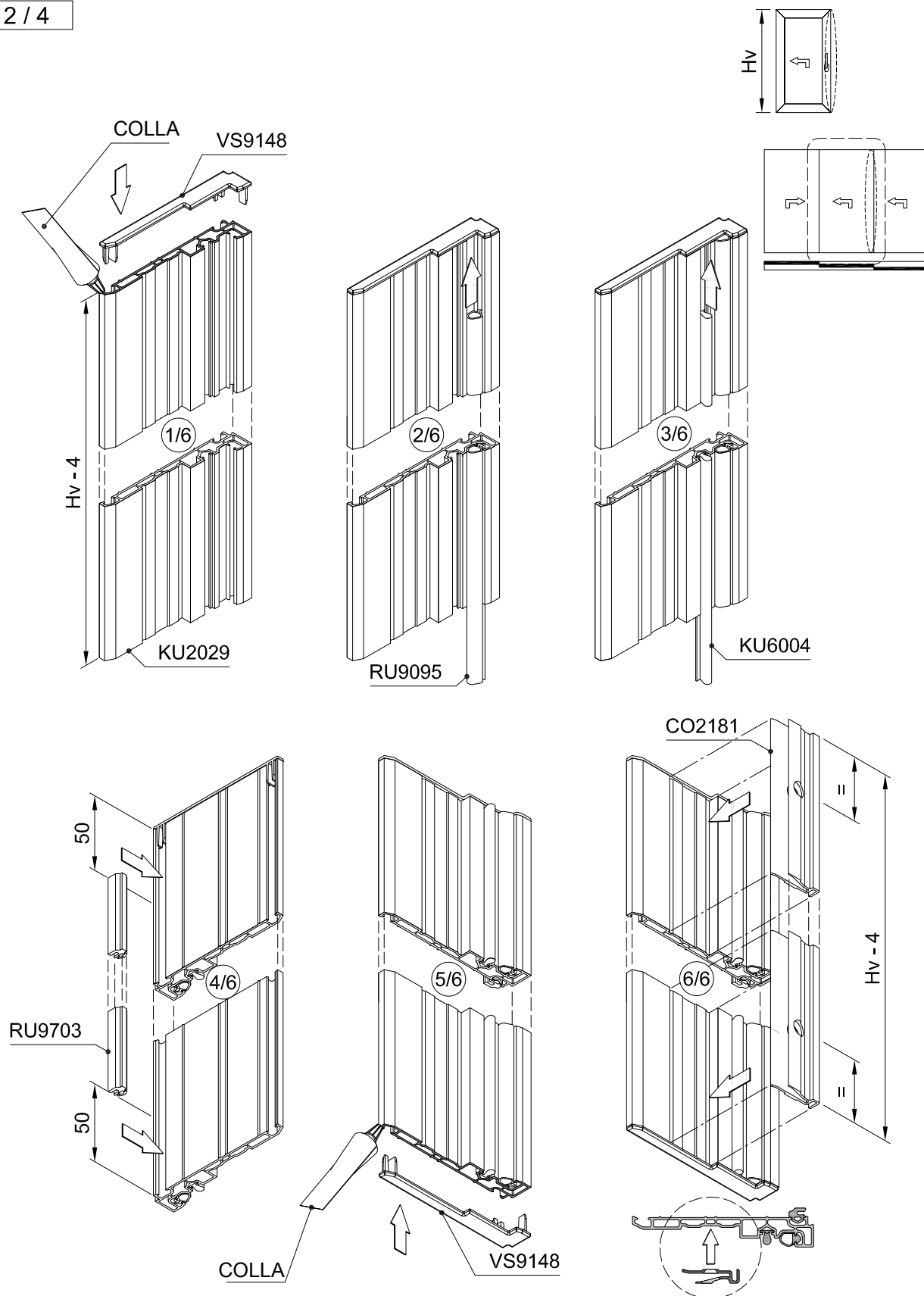

**3-BINARI ALZANTE-SCORREVOLE LATO FERRAMENTA - ASSEMBLAGGIO LABIRINTO**

3 / 4

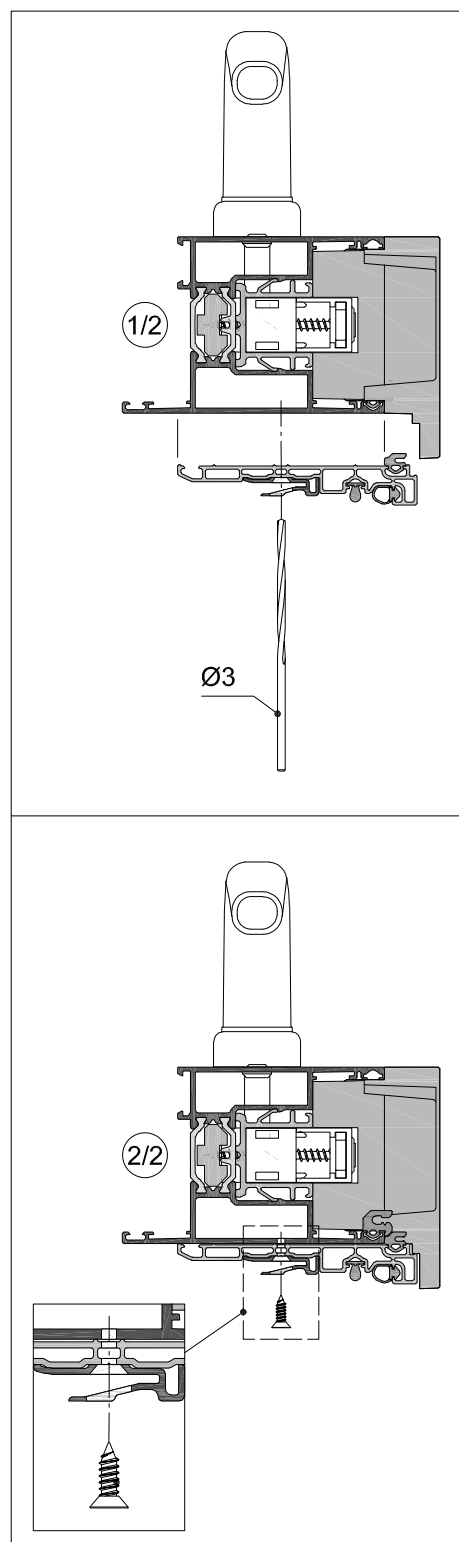
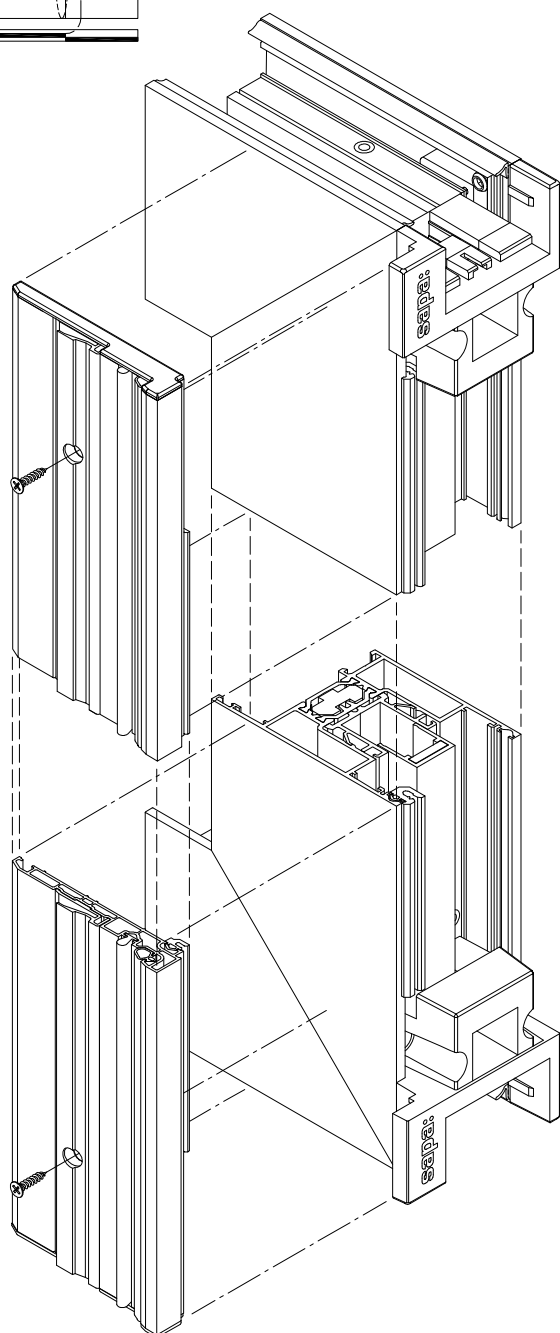
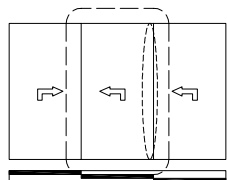
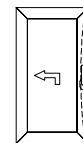

 **C160-ASS-2237L**

## ASSEMBLAGGIO ACCESSORI ANTA

### 3-BINARI ALZANTE-SCORREVOLE LATO FERRAMENTA - ASSEMBLAGGIO C9A001/C9A002

4 / 4

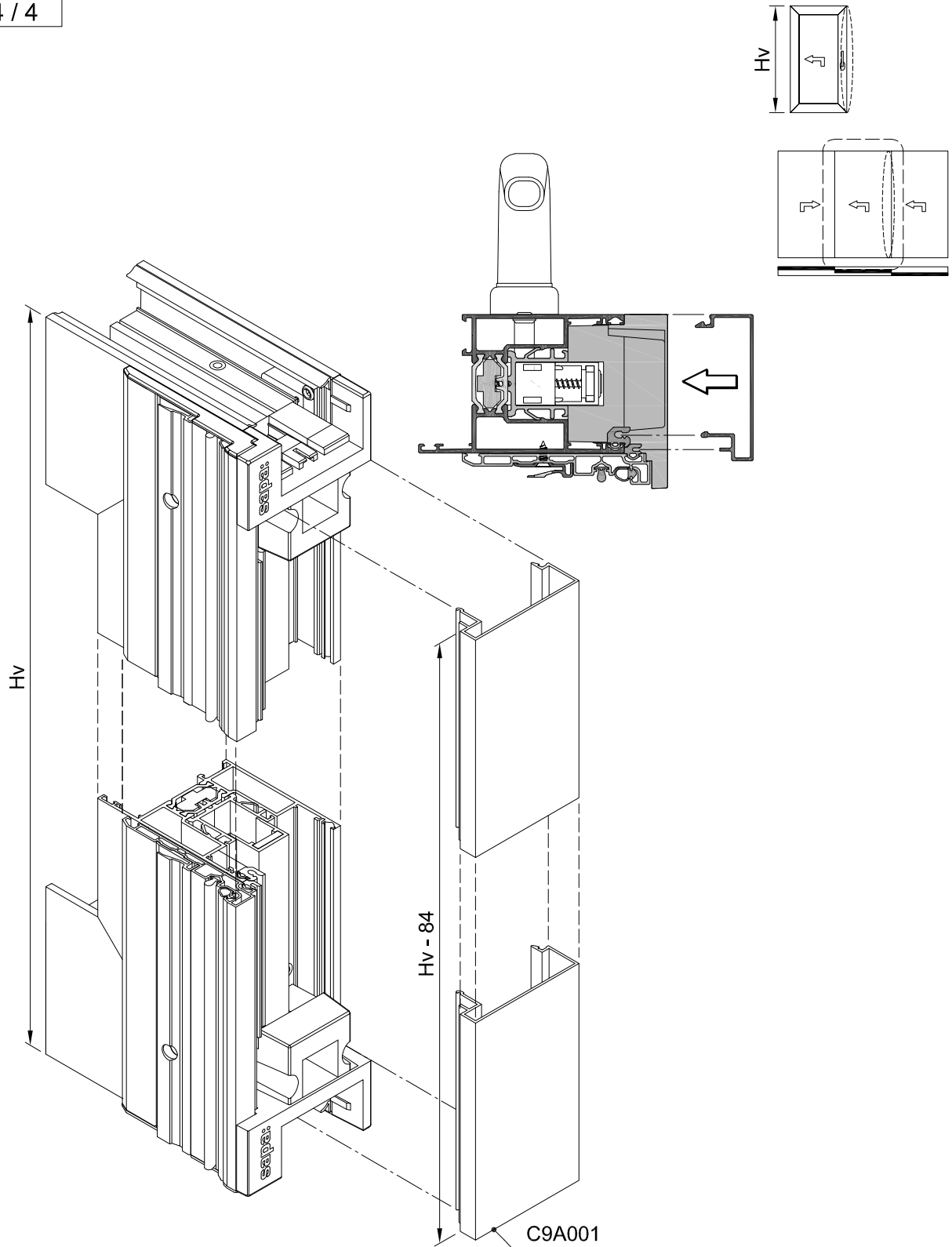

**FISSO-ALZANTE-SCORREVOLE-FISSO LATO FERRAMENTA - VS9211 E RU9094**

1 / 5

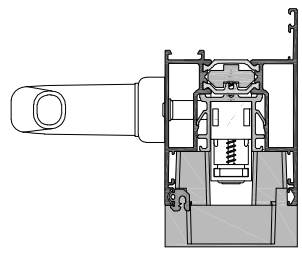
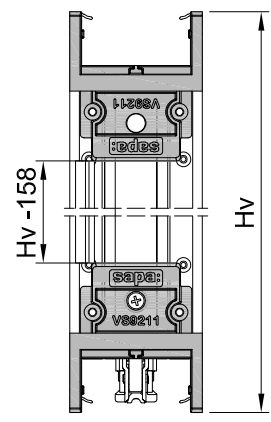
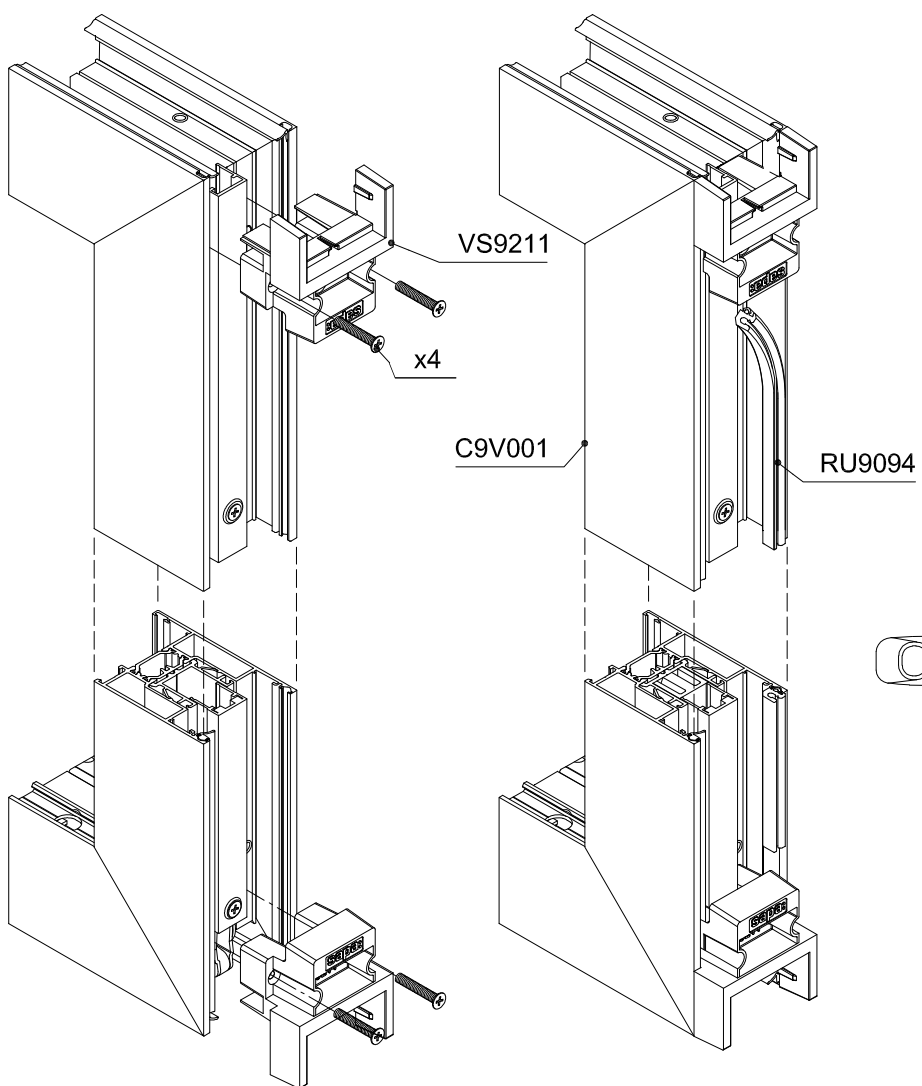
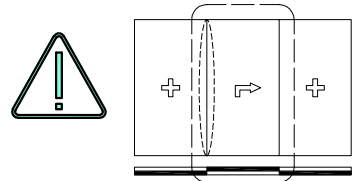
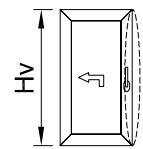
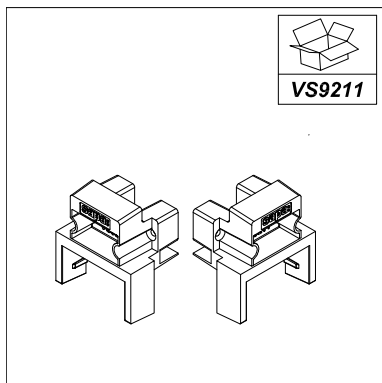

 **C160-ASS-2228L**



## ASSEMBLAGGIO ACCESSORI ANTA

### FISSO-ALZANTE-SCORREVOLE-FISSO LATO FERRAMENTA - LABIRINTO

2 / 5

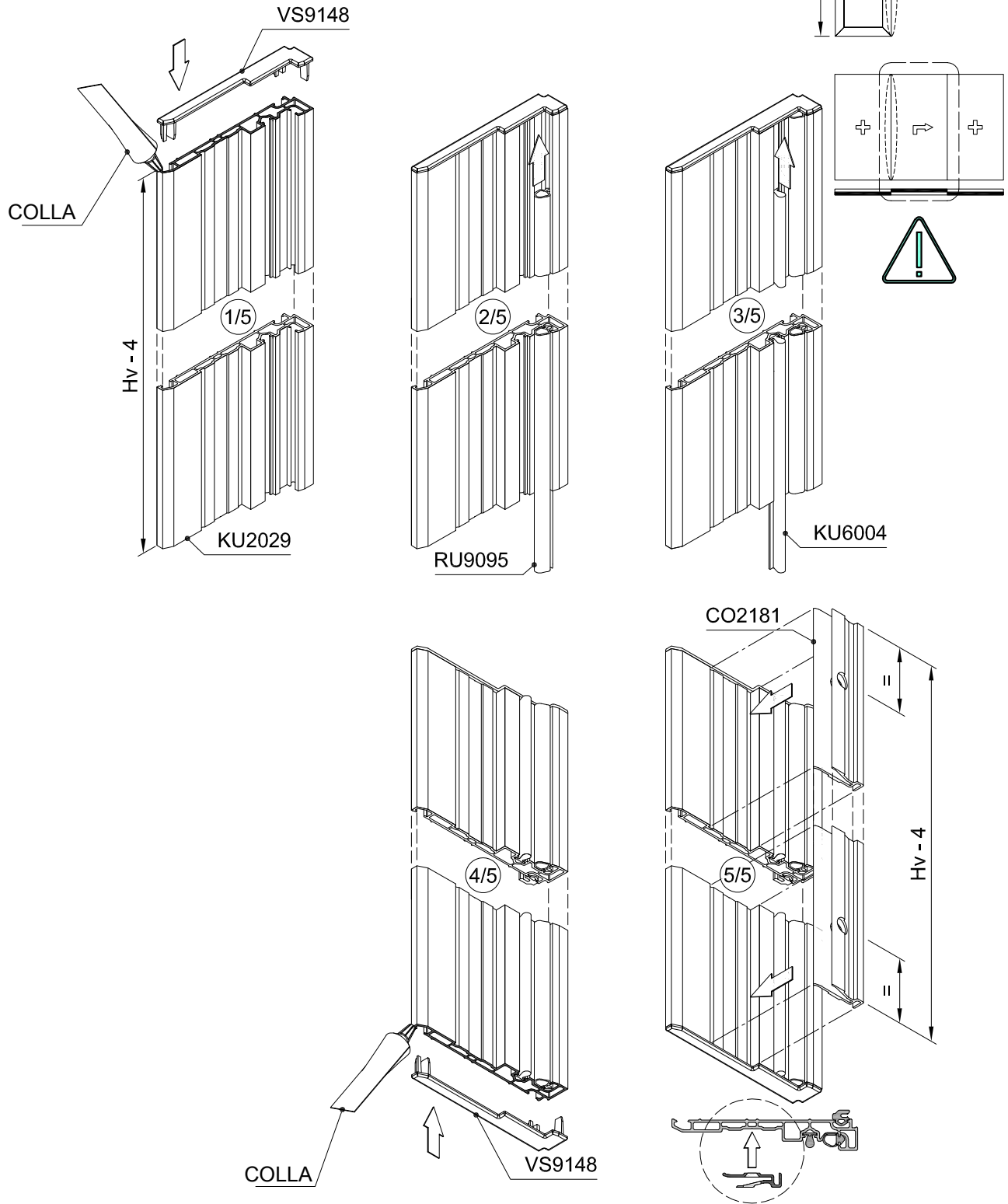

**FISSO-ALZANTE-SCORREVOLE-FISSO LATO FERRAMENTA - ASSEMBLAGGIO LABIRINTO**

3 / 5

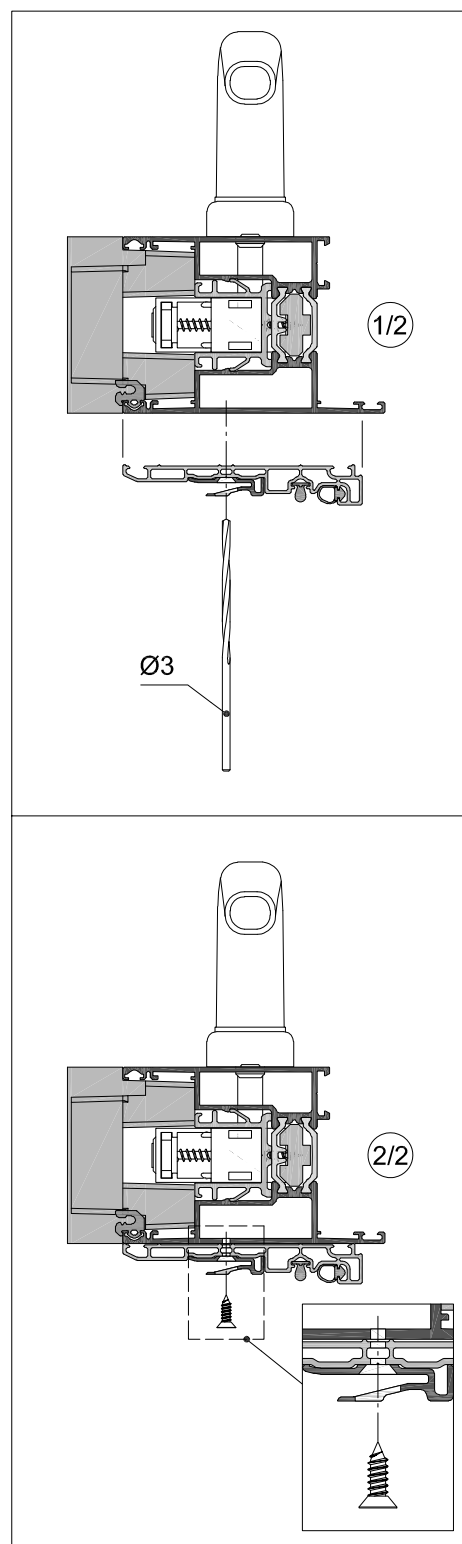
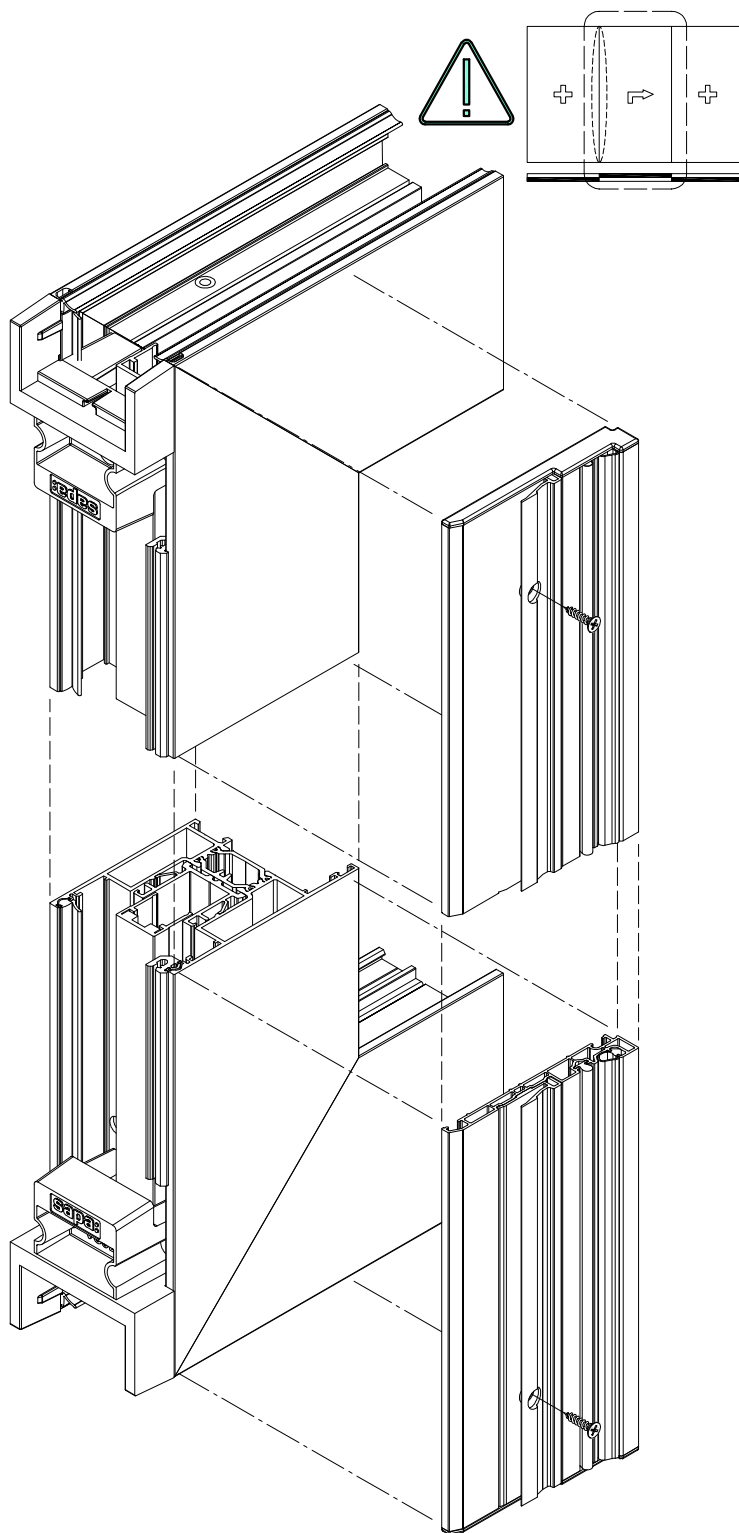
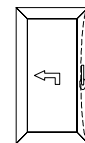

 **C160-ASS-2230L**

## ASSEMBLAGGIO ACCESSORI ANTA

### FISSO-ALZANTE-SCORREVOLE-FISSO LATO FERRAMENTA - ASSEMBLAGGIO C9A007

4 / 5

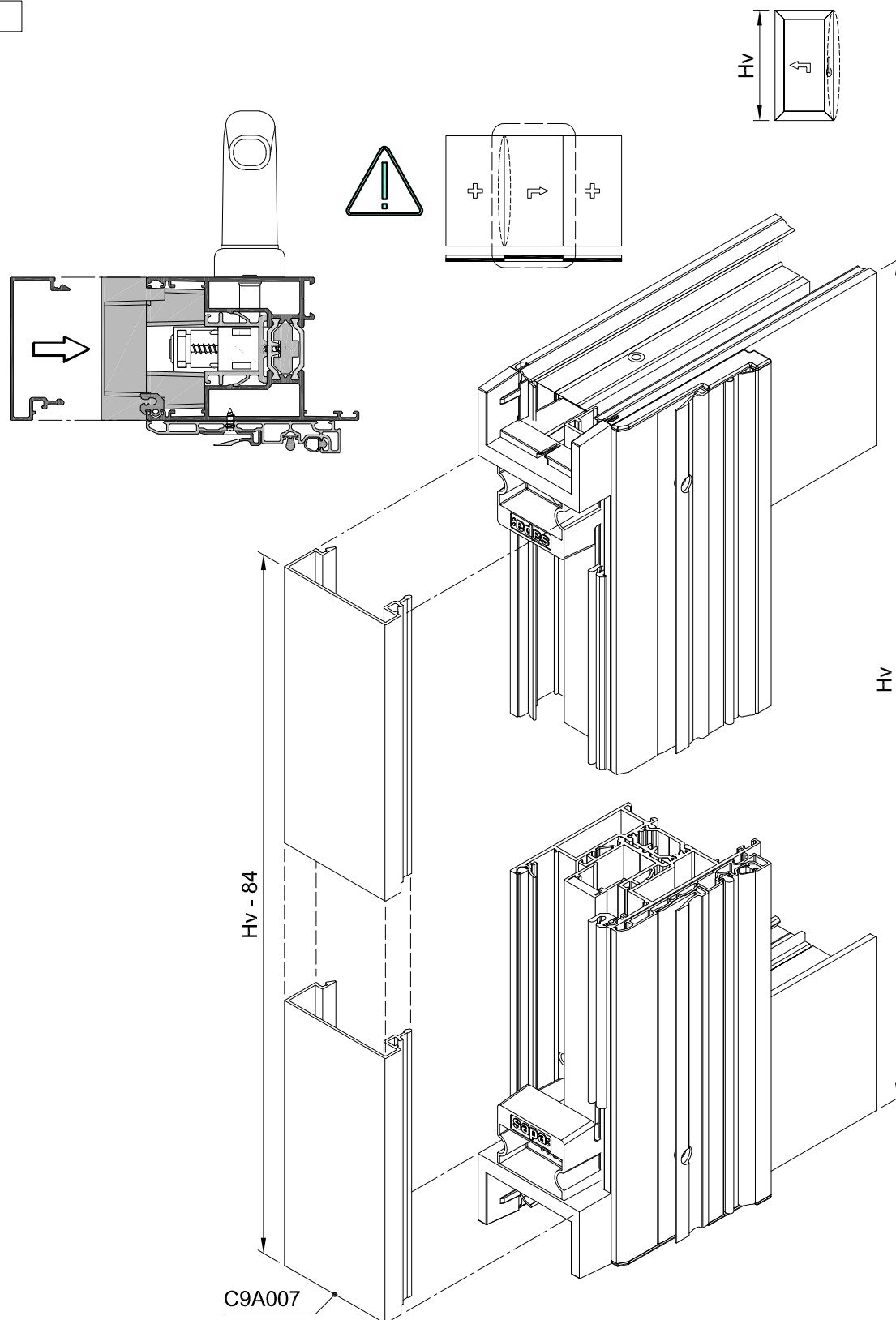

**FISSO-ALZANTE-SCORREVOLE-FISSO LATO FERRAMENTA - ASSEMBLAGGIO RU9009**

5 / 5

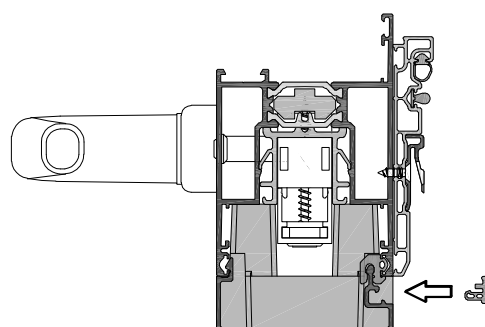
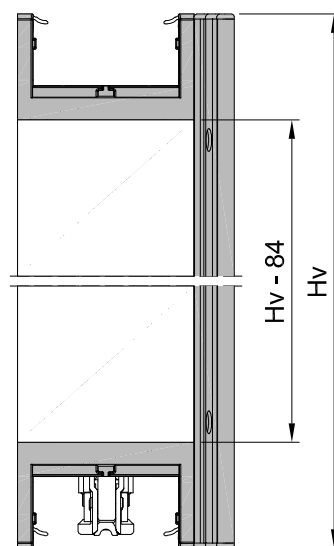
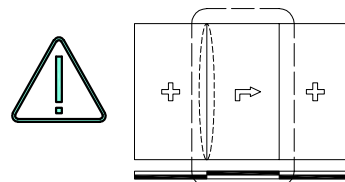
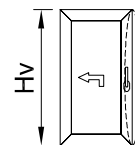
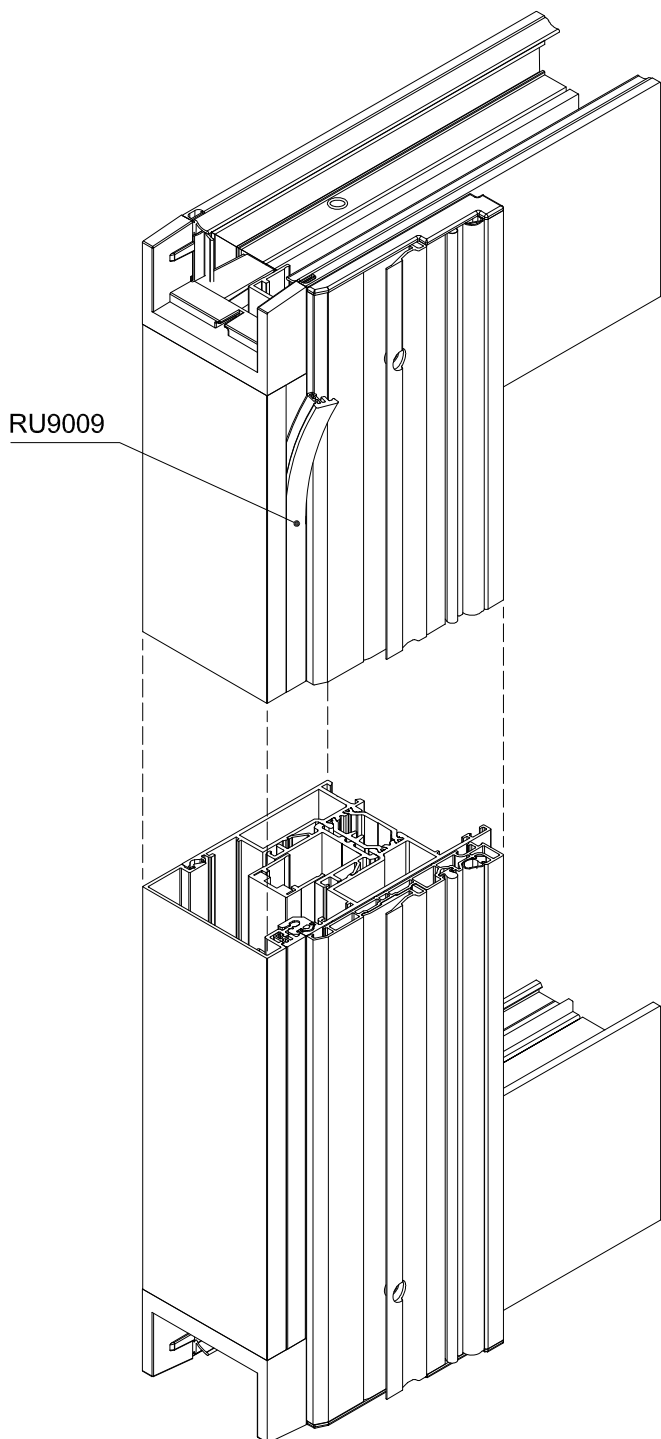

## ASSEMBLAGGIO ACCESSORI ANTA

### FISSO-ALZANTE-SCORREVOLE-FISSO LATO FERRAMENTA

1 / 5

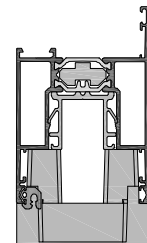
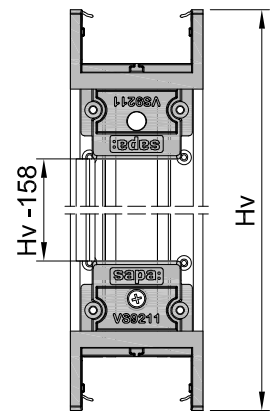
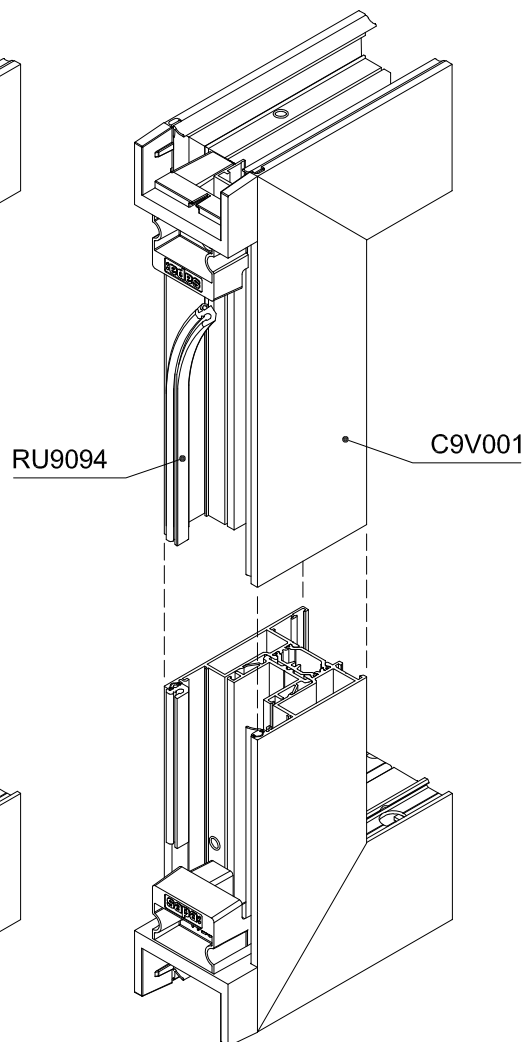
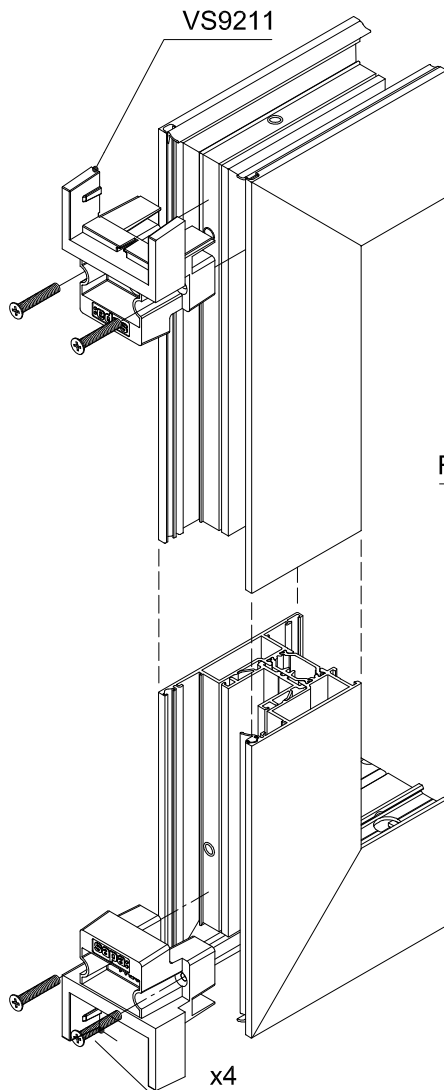
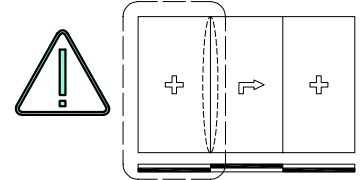
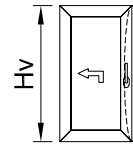
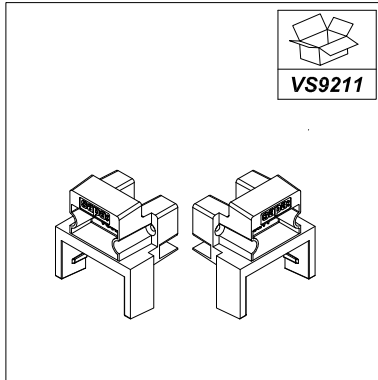

C160-ASS-2257L

**FISSO-ALZANTE-SCORREVOLE-FISSO LATO FERRAMENTA**

2 / 5

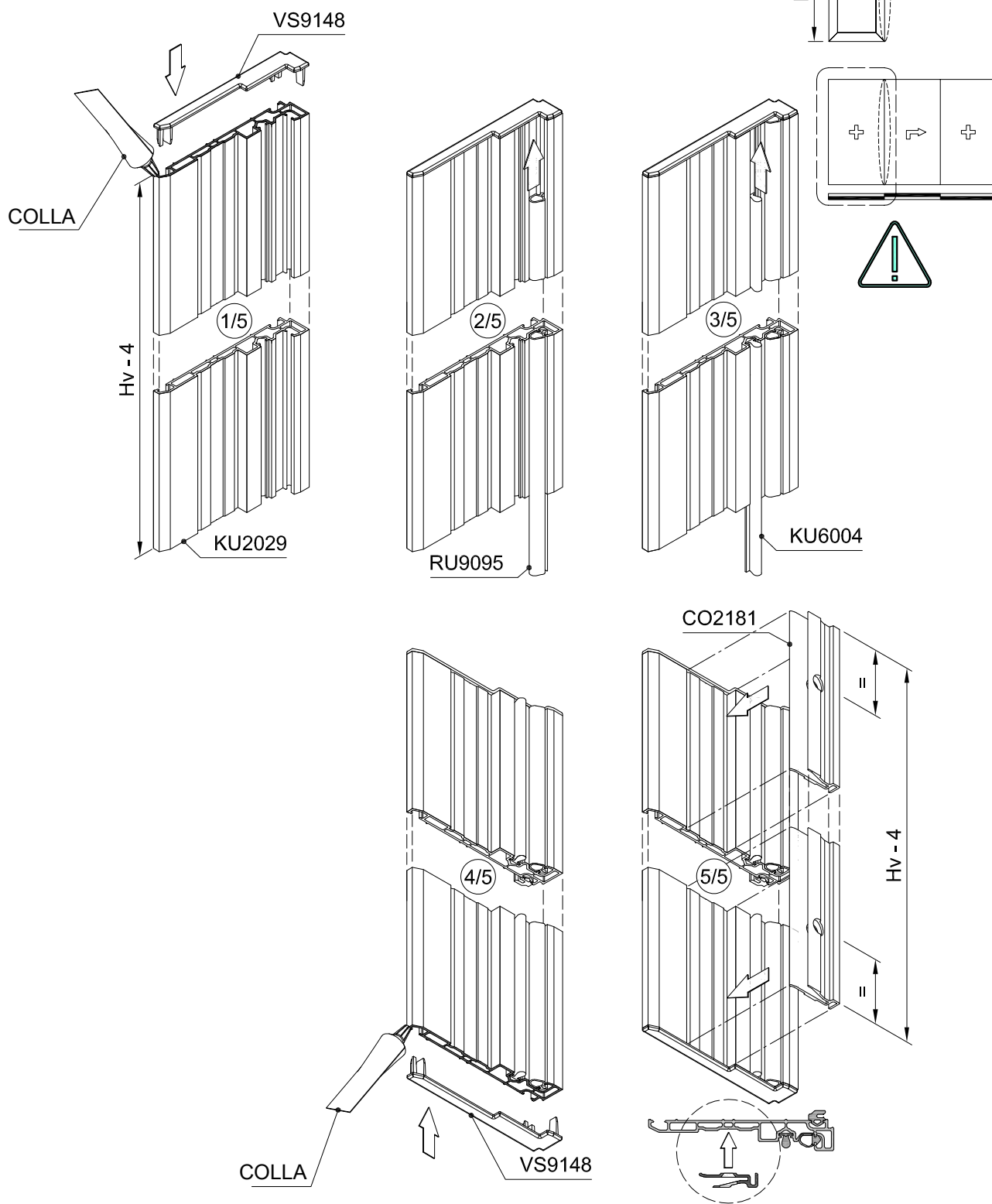

### FISSO-ALZANTE-SCORREVOLE-FISSO LATO FERRAMENTA - ASSEMBLAGGIO LABIRINTO

3 / 5

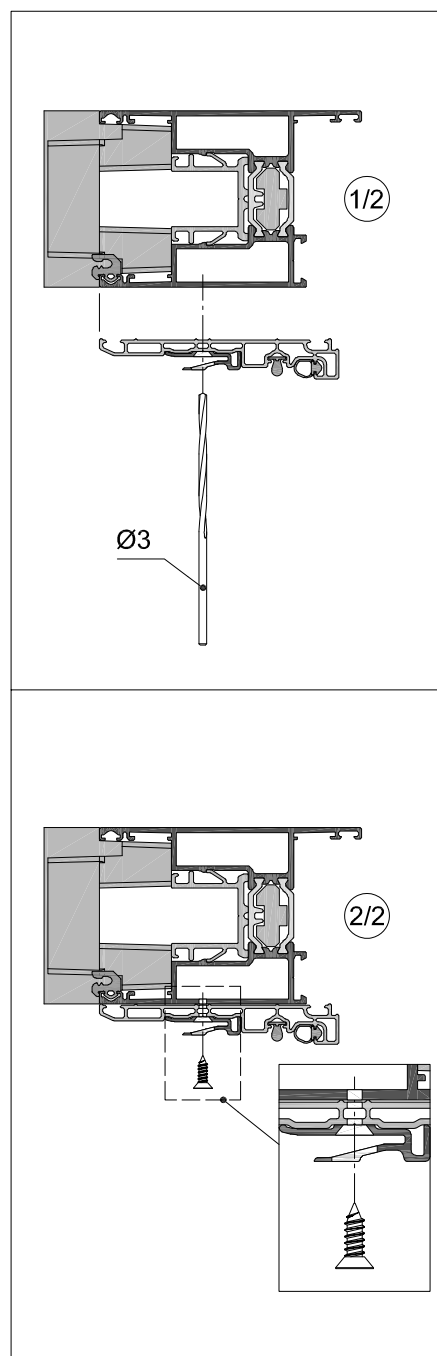
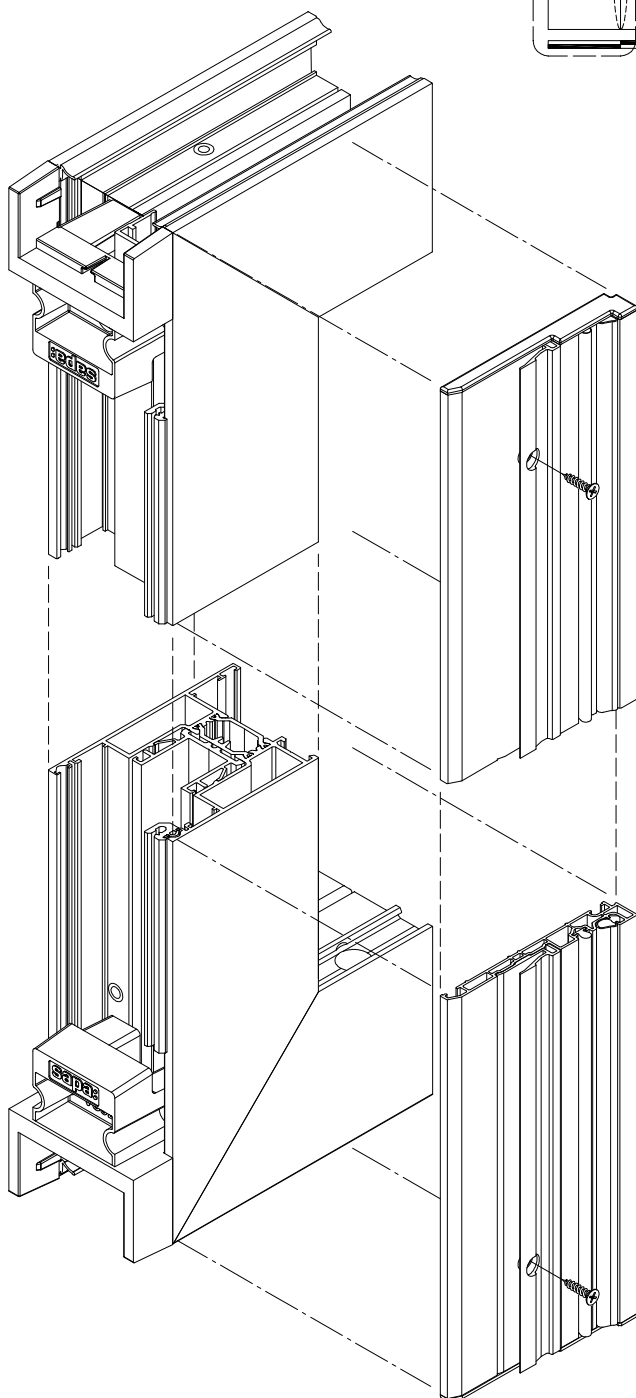
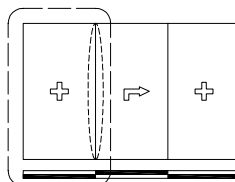
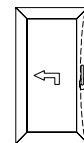

**FISSO-ALZANTE-SCORREVOLE-FISSO LATO FERRAMENTA - BT6013 E C9A007**

4 / 5

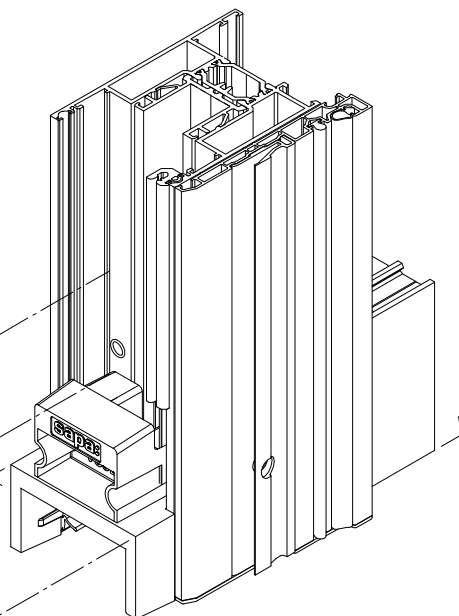
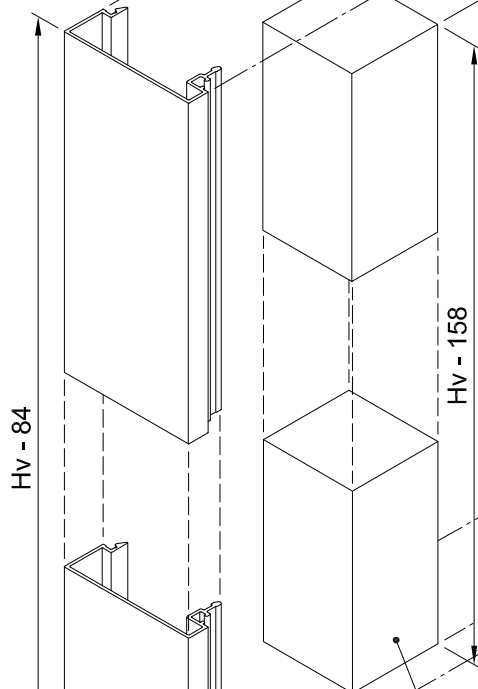
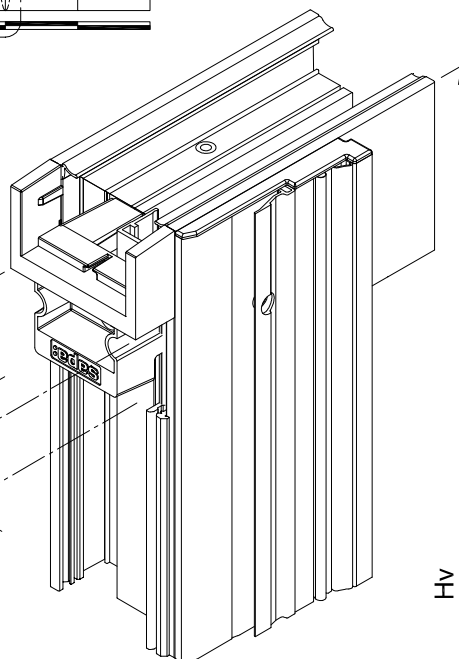
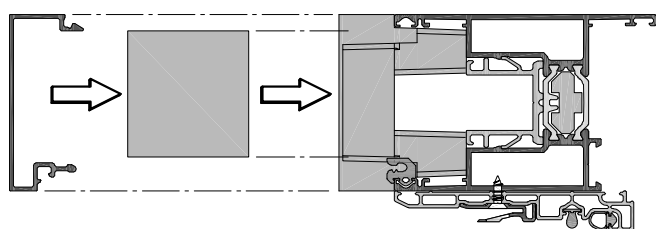
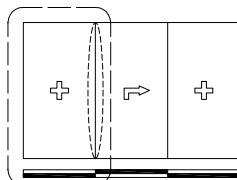
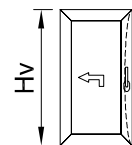

C9A007

BT60013



### FISSO-ALZANTE-SCORREVOLE-FISSO LATO FERRAMENTA - ASSEMBLAGGIO RU9009

5 / 5

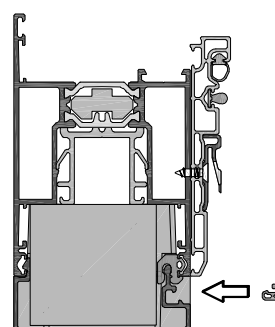
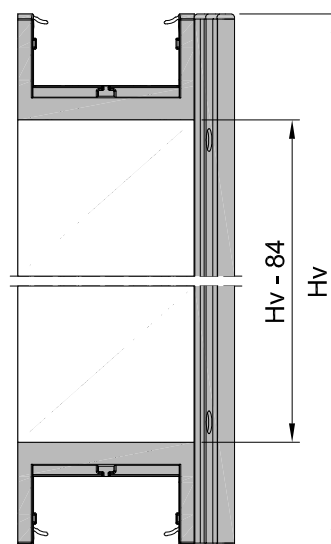
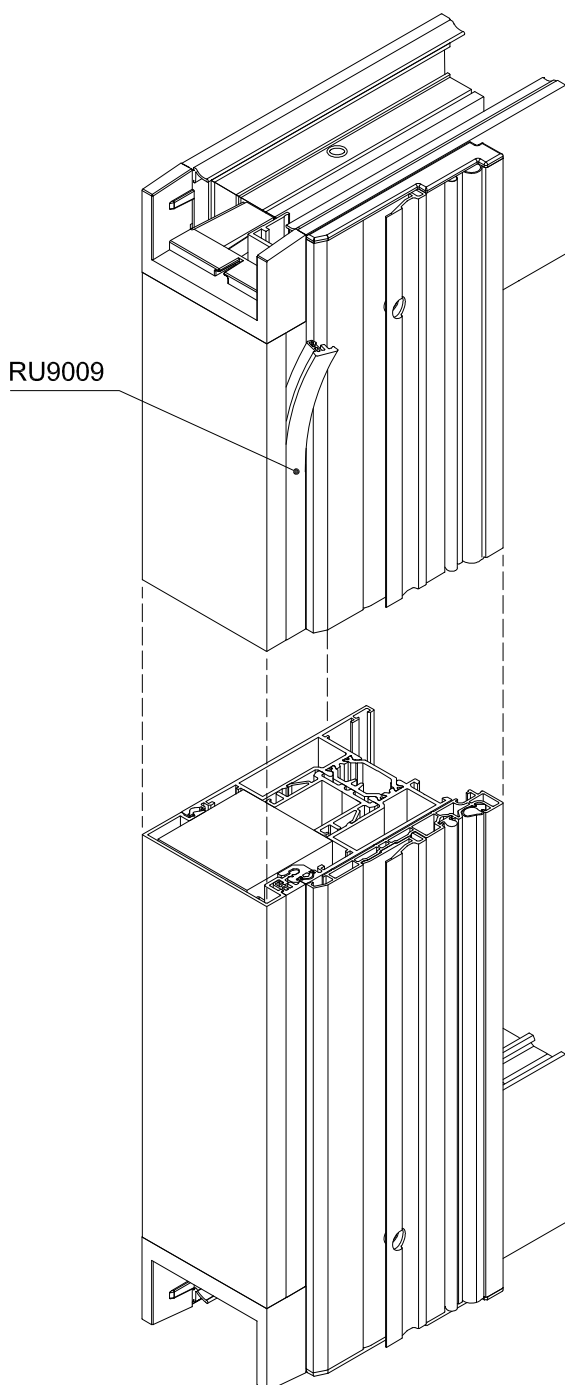
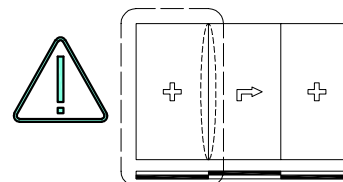
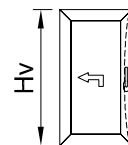

**ANTA PASSIVA SCHEMA 4 ANTE - PREPARAZIONE RU0099**

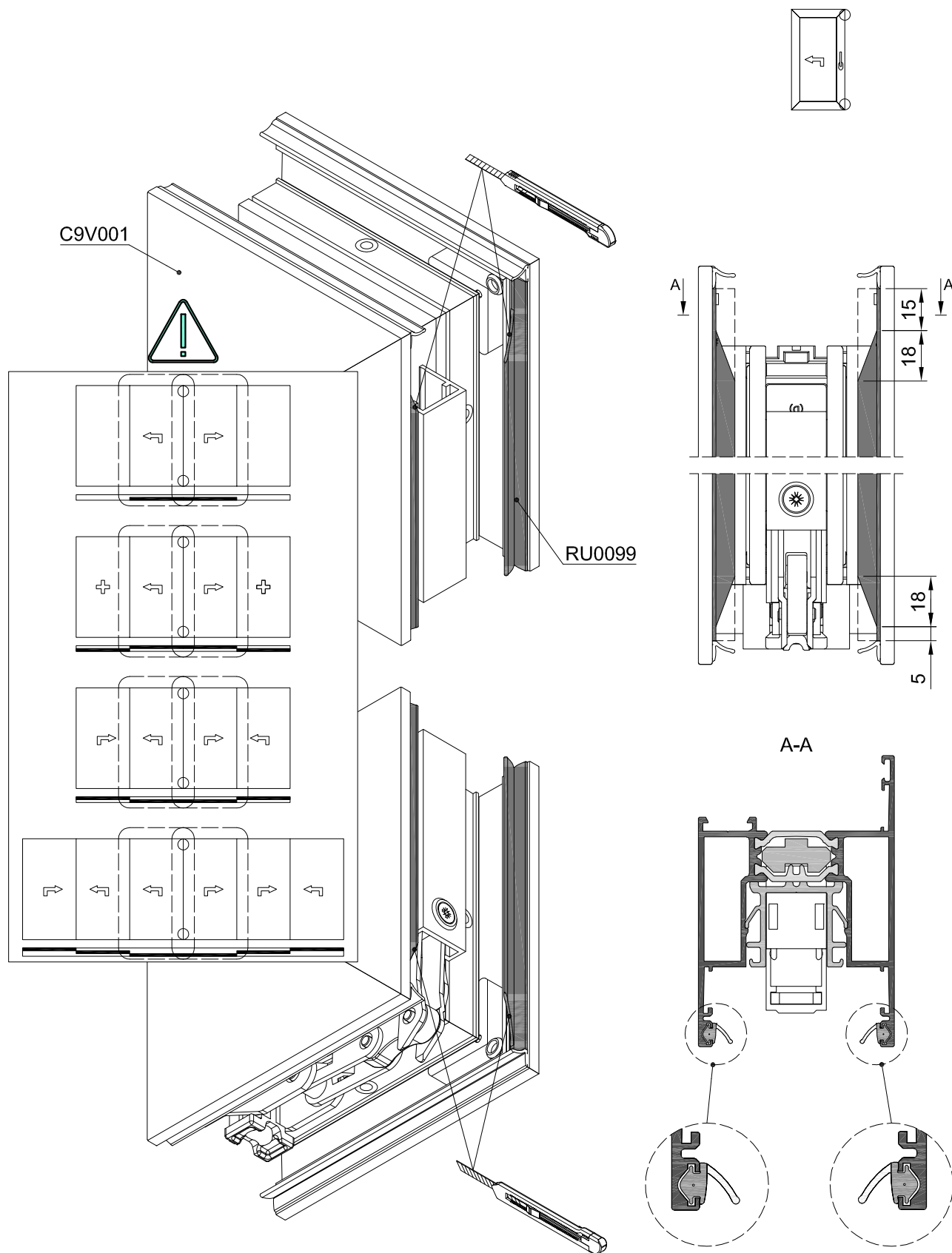

### ANTA PASSIVA SCHEMA 4 ANTE - PREPARAZIONE C9C002

1 / 6

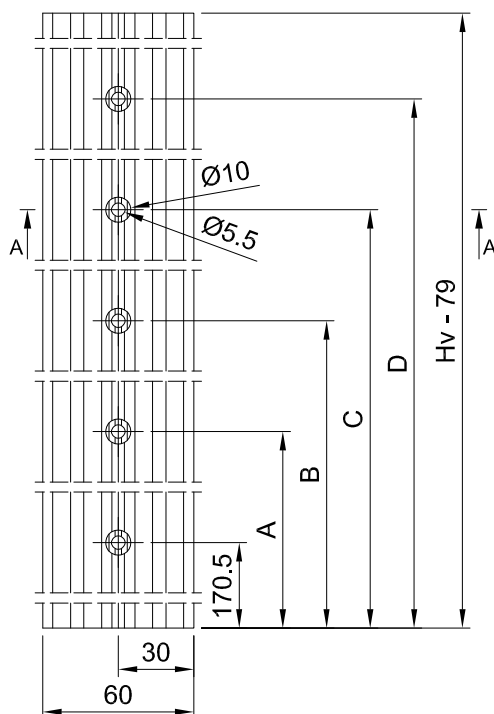
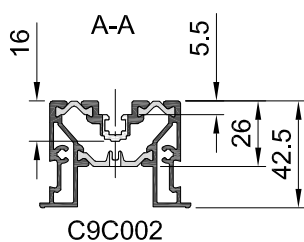
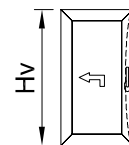

A	B	C	D		Hv
670.5	1120.5	1520.5	/	<b>ZB0034</b>	1904 - 2203
		1820.5		<b>ZB0035</b>	2204 - 2503
		2120.5		<b>ZB0036</b>	2504 - 2803
		1820.5	Hv - 358,5	<b>ZB0035*</b>	2804 - 3103
		2120.5		<b>ZB0036*</b>	3104 - 3403
/	520.5	920.5	/	<b>ZB0033</b>	1303 - 1903

\* + ZB0046

**ANTA PASSIVA SCHEMA 4 ANTE - ASSEMBLAGGIO C9C002**

2 / 6

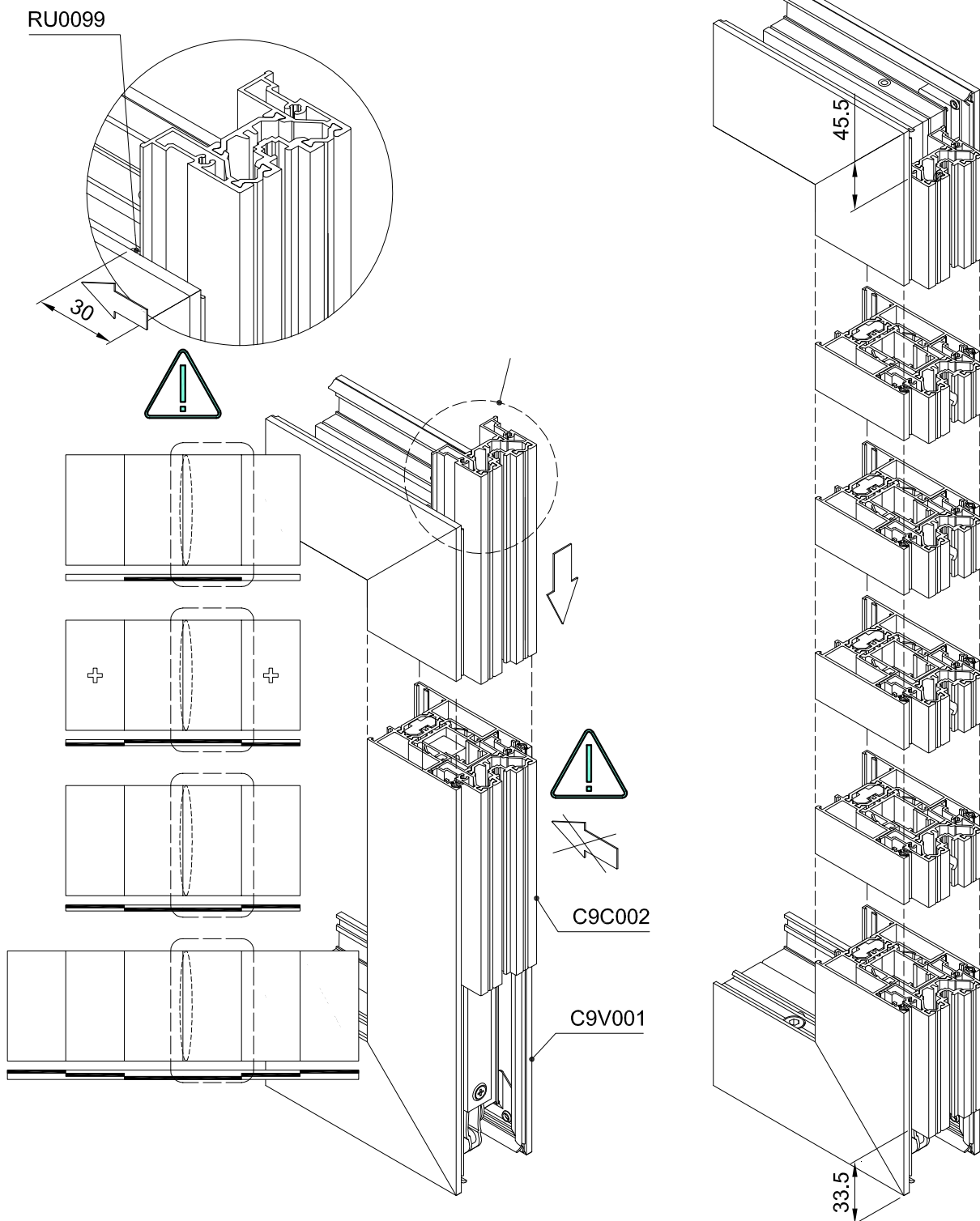
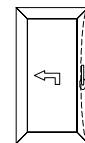

 **C160-ASS-2186L**

### ANTA PASSIVA SCHEMA 4 ANTE - ASSEMBLAGGIO C9C002

3 / 6

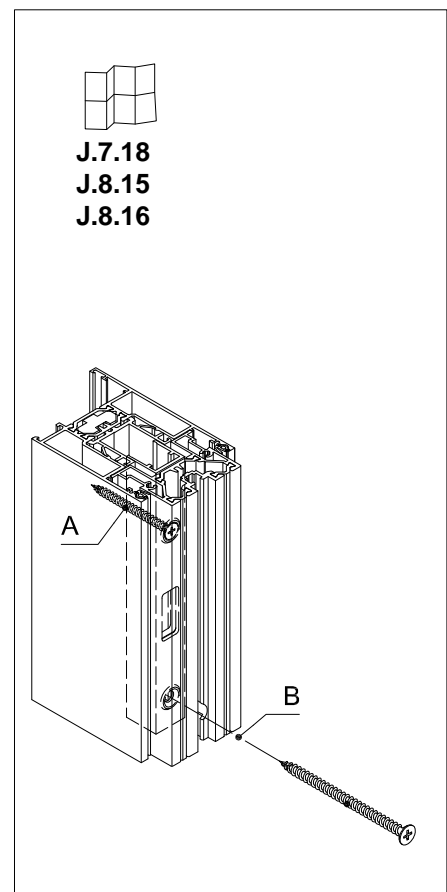
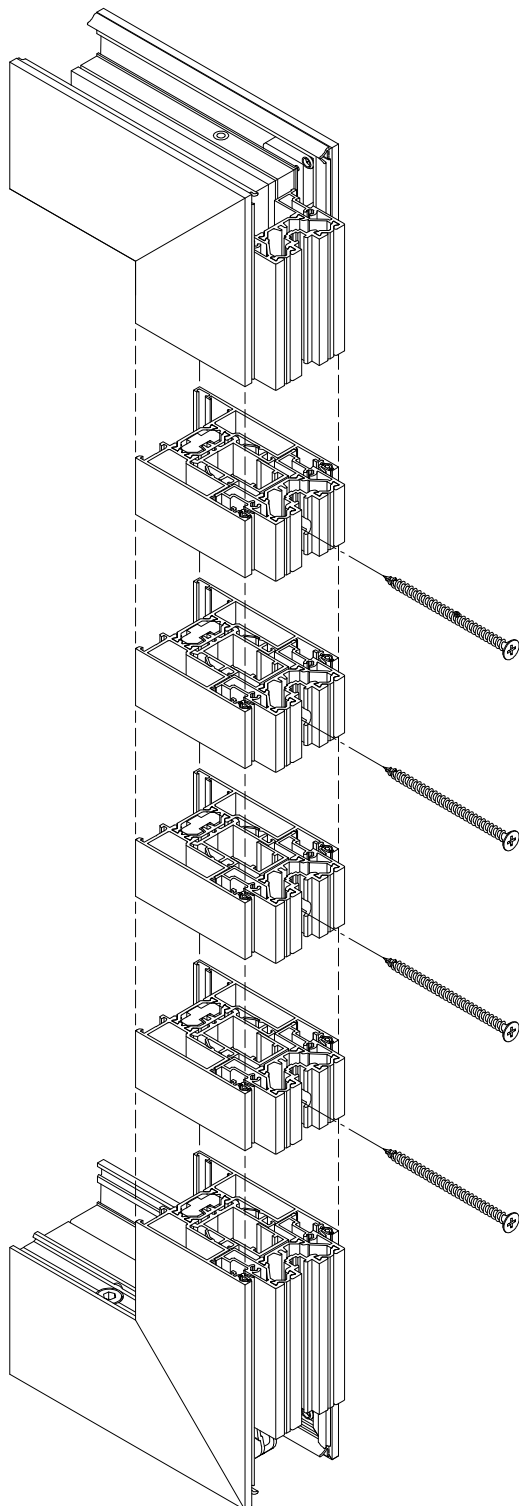
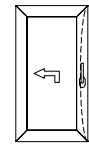

**ANTA PASSIVA SCHEMA 4 ANTE - INSTALLAZIONE TAPPO SIGILLATURA INFERIORE**

4 / 6



J.12.3

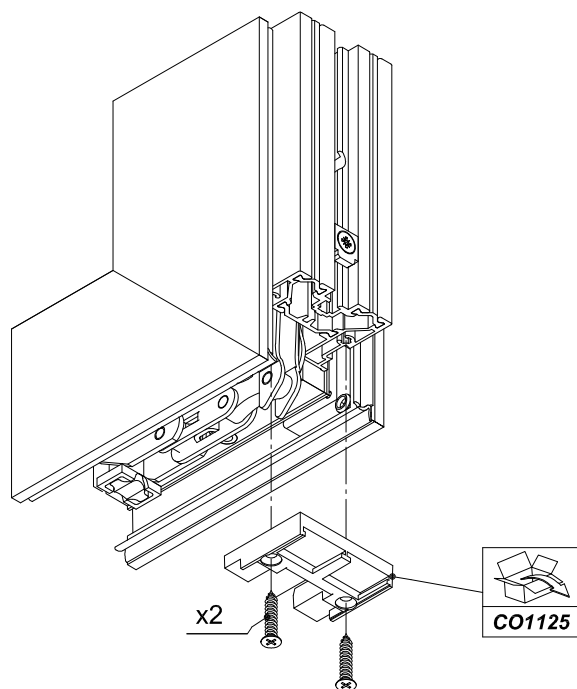
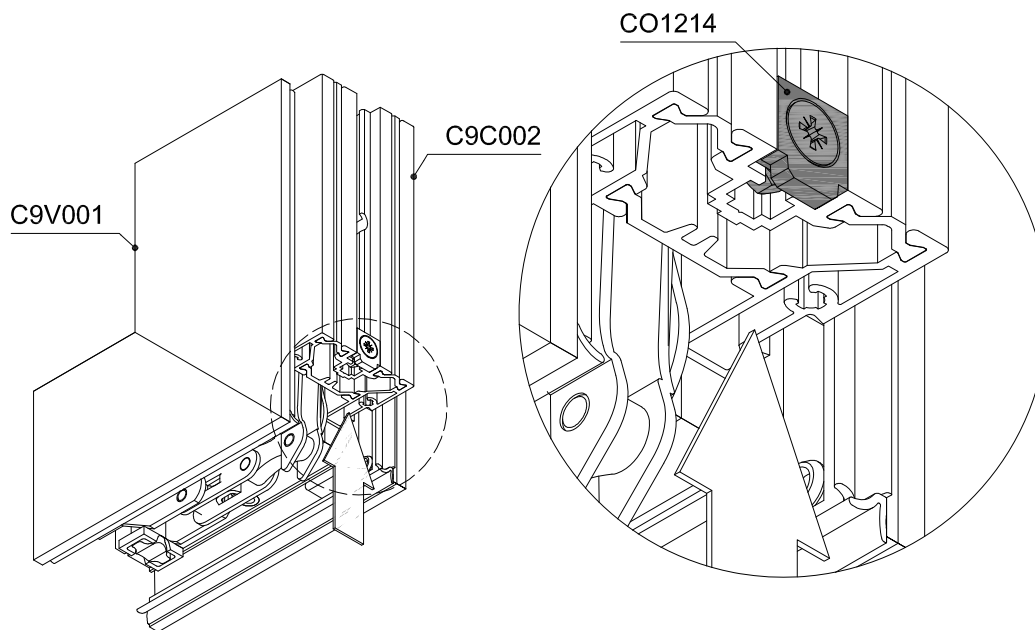
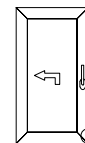

## ASSEMBLAGGIO ACCESSORI ANTA

### ANTA PASSIVA SCHEMA 4 ANTE - INSTALLAZIONE PUNTI DI CHIUSURA

5 / 6



J.12.4

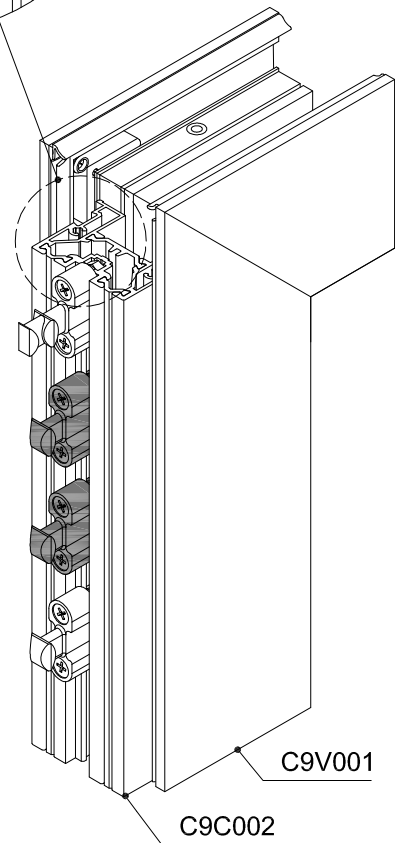
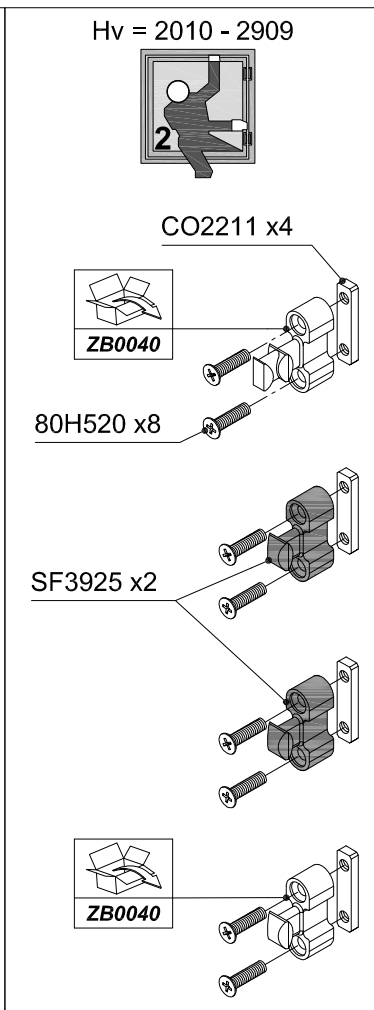
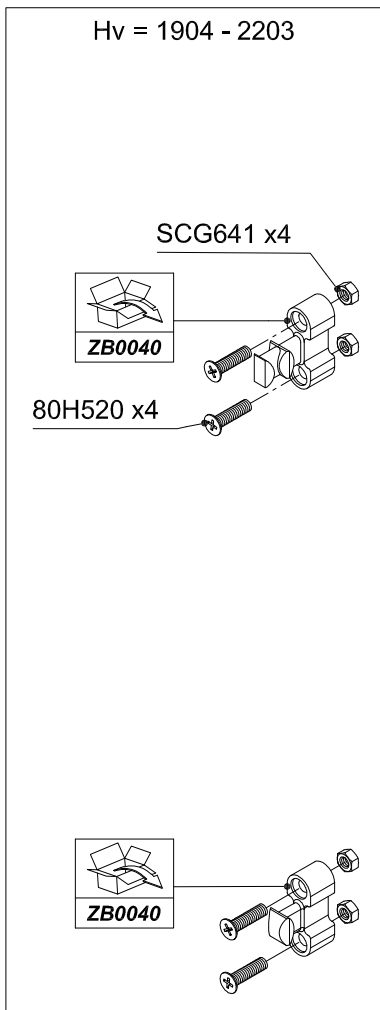
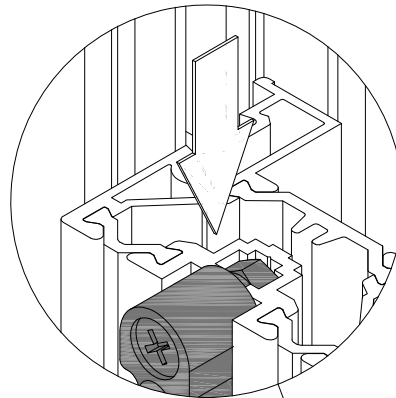
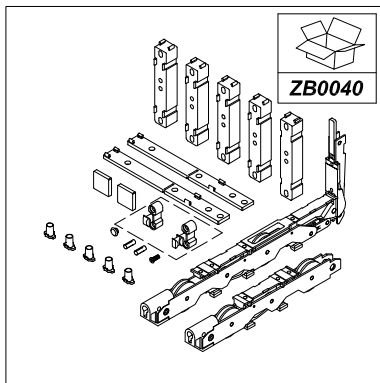
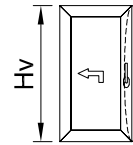

**ANTA PASSIVA SCHEMA 4 ANTE - INSTALLAZIONE TAPPO SIGILLATURA SUPERIORE**

6 / 6



J.12.3

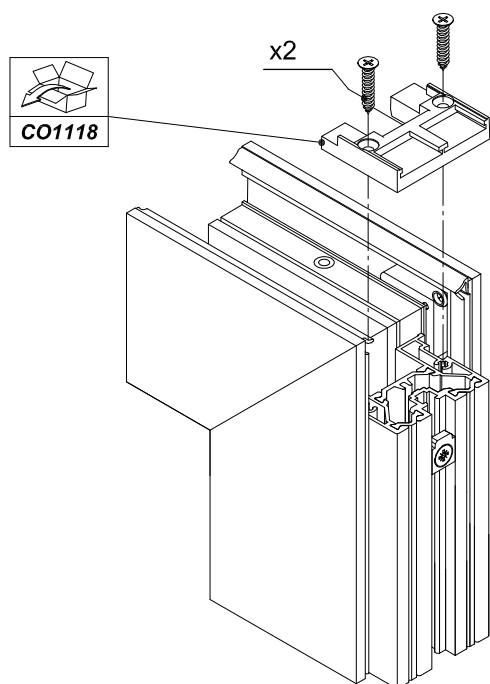
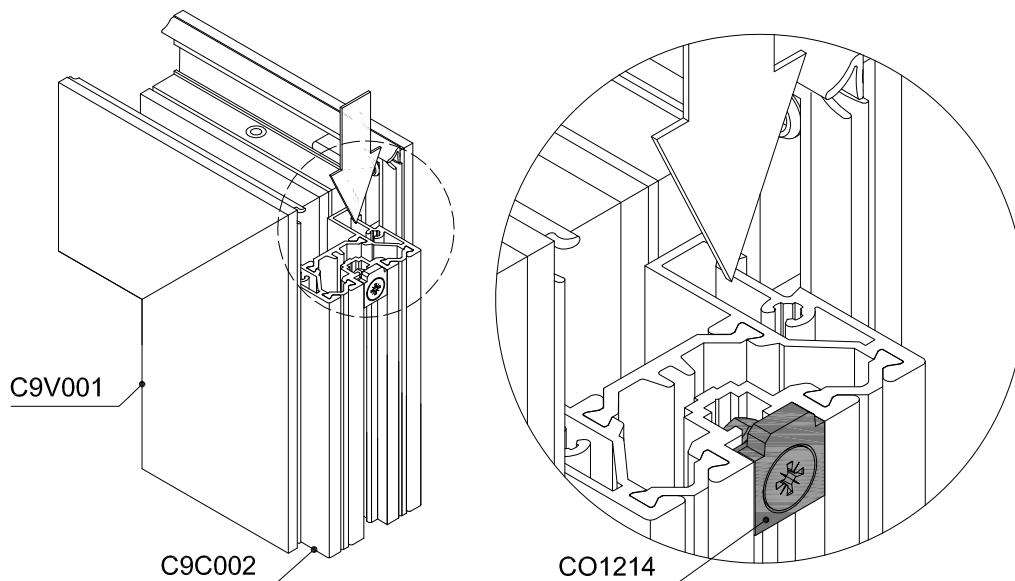
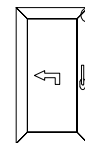





**CONTENUTO**

Installazione ante su telai.....	J.12.1
Contenuto.....	J.12.1
2-binari.....	J.12.2
3-binari.....	J.12.3
Uso standard.....	J.12.6
Aggiustamenti.....	J.12.6
Anta fissa scorrevole-fisso - VS5128/VS5129.....	J.12.6
Anta fissa scorrevole-fisso - assemblaggio VS5128 e BT6015.....	J.12.7
Anta fissa scorrevole-fisso - fori per guide.....	J.12.8
Scorrevole-fisso - VS5129 e BT6026.....	J.12.9
Scorrevole-fisso - assemblaggio anta fissa su telai.....	J.12.10
Scorrevole-fisso - rimozione profilato cartellina.....	J.12.11
Scorrevole-fisso - assemblaggio BT6026 e VS5129 superiore.....	J.12.12
Scorrevole-fisso - fissaggio con SCZ617.....	J.12.13
Scorrevole-fisso - fissaggio con SCZ617.....	J.12.14
Scorrevole-fisso - base tappo di tenuta e cartellina anta.....	J.12.15
Scorrevole-fisso - posizionamento anta apribile sul telaio.....	J.12.16
Assemblaggio tappo di tenuta superiore- 2-binari telai.....	J.12.20
Assemblaggio tappo di tenuta superiore- 3-binari telai.....	J.12.21
Assemblaggio SV9002.....	J.12.22

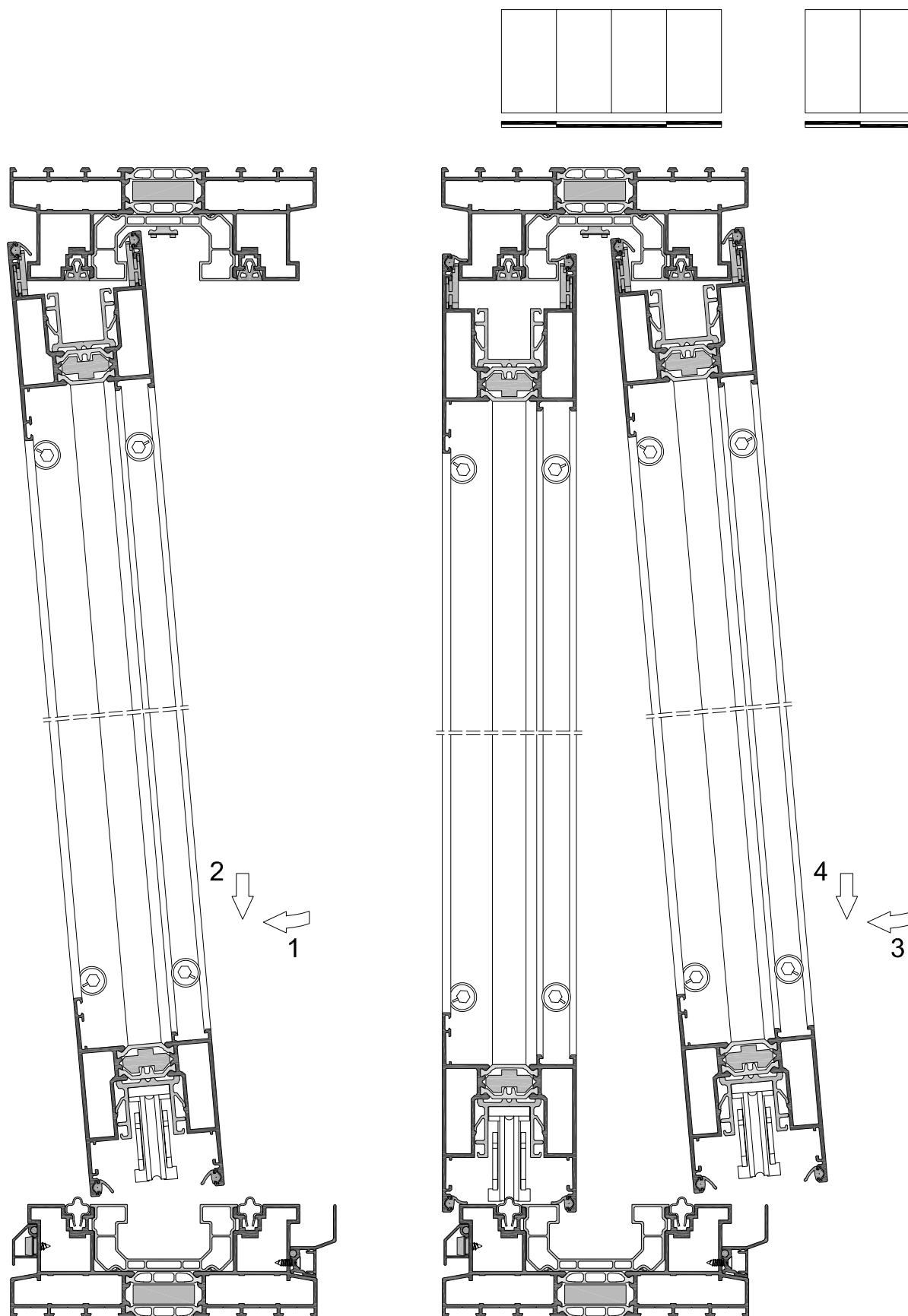
**2-BINARI**



 **C160-ASS-1336**

3-BINARI

1 / 3

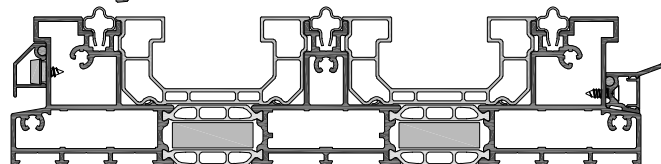
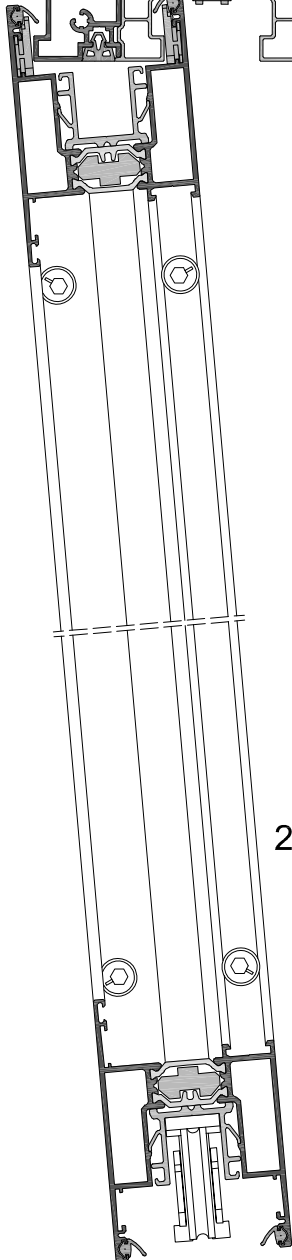
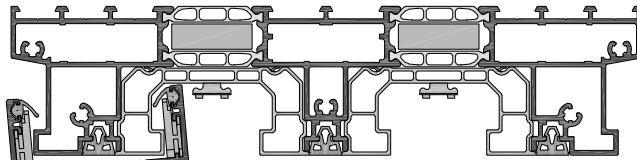
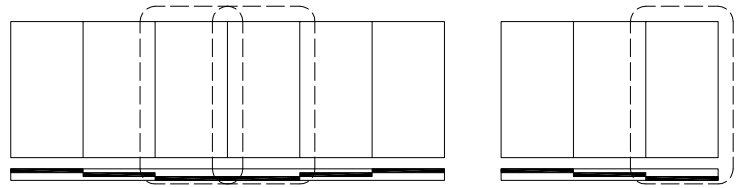

 C160-ASS-1027

3-BINARI

2 / 3

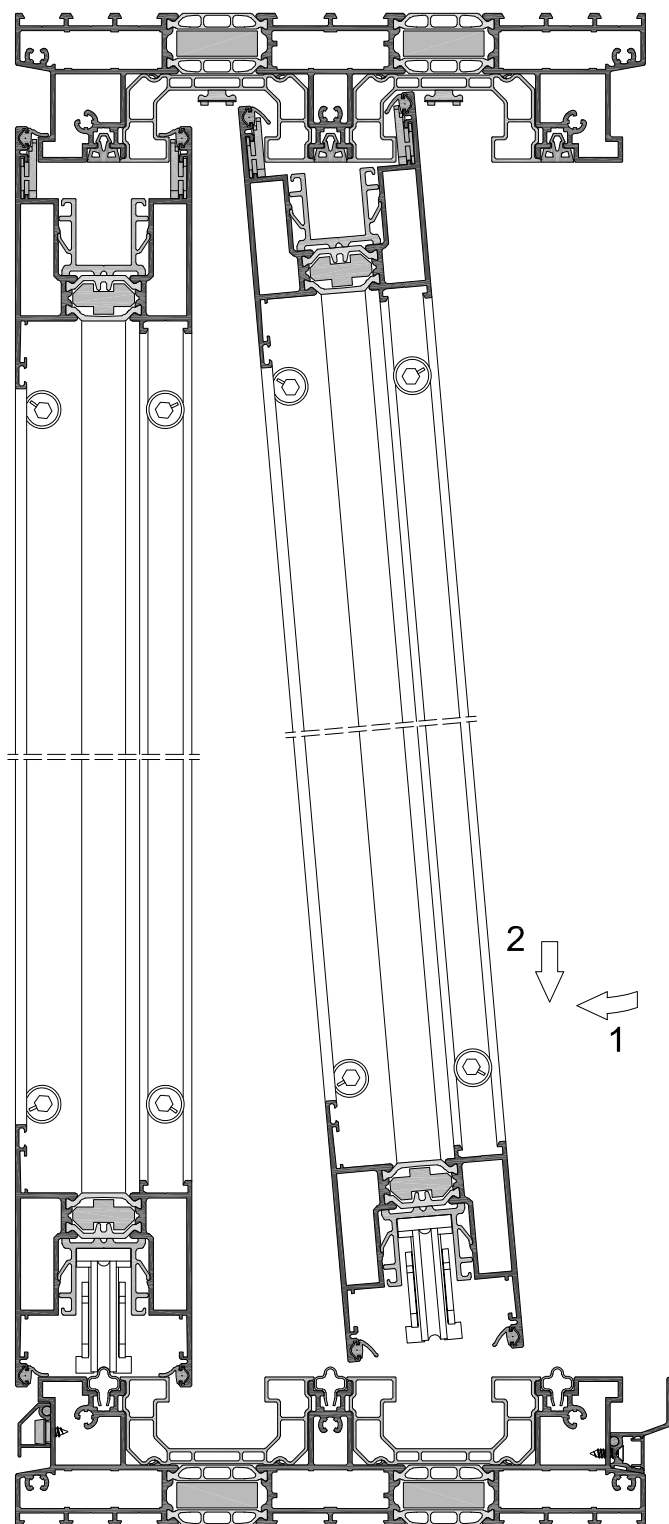
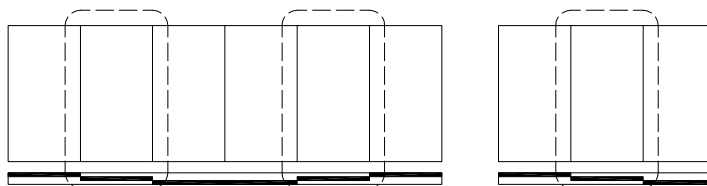

 **C160-ASS-1028**

3-BINARI

3 / 3

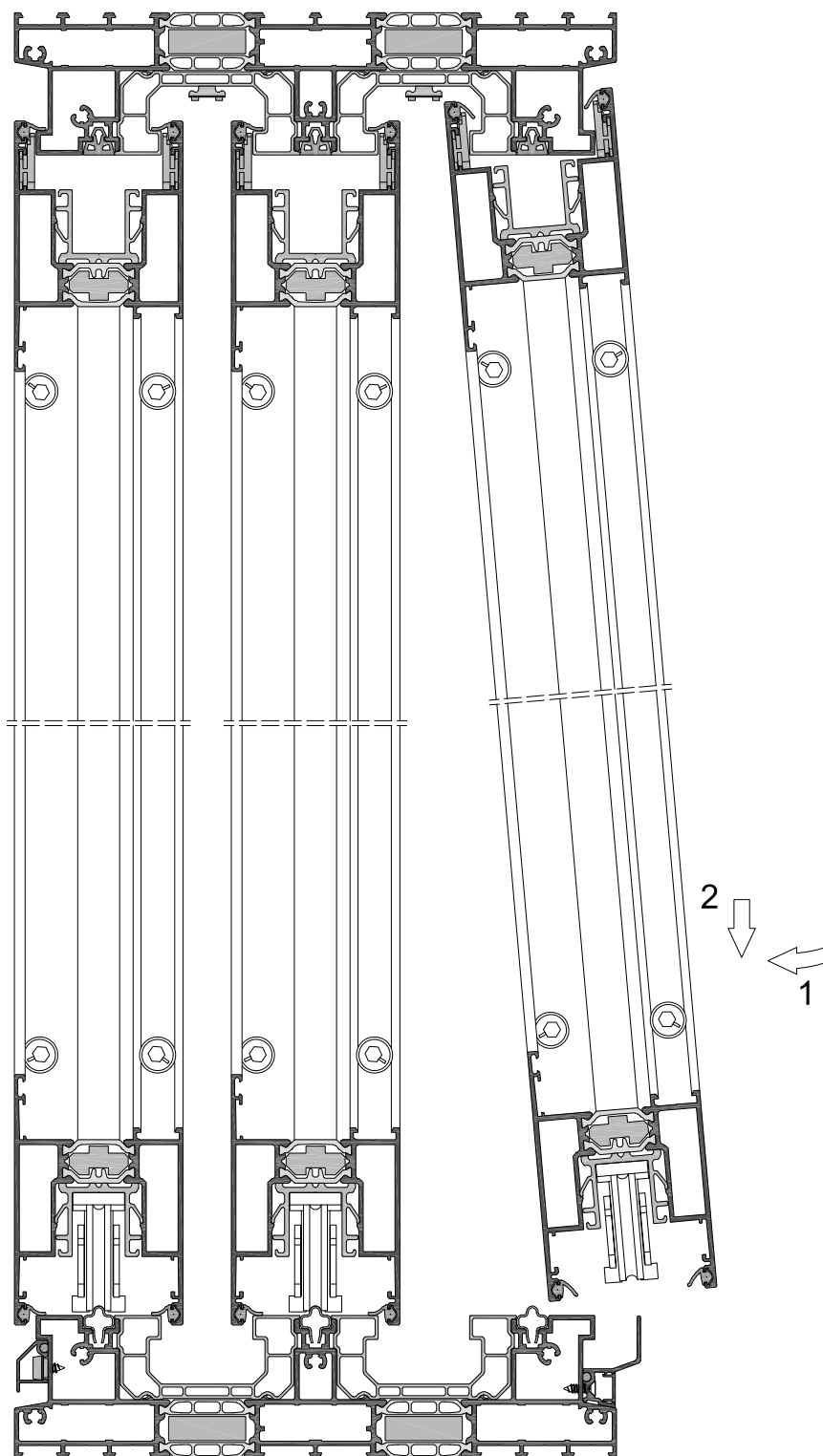
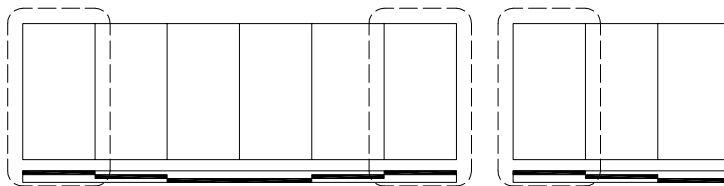

 C160-ASS-1029

**ANTA FISSA SCORREVOLE-FISSO - VS5128/VS5129**

1 / 10

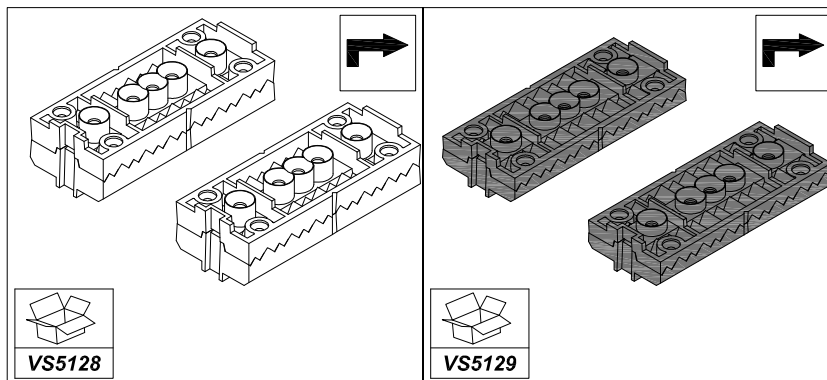

**Uso  
STANDARD**

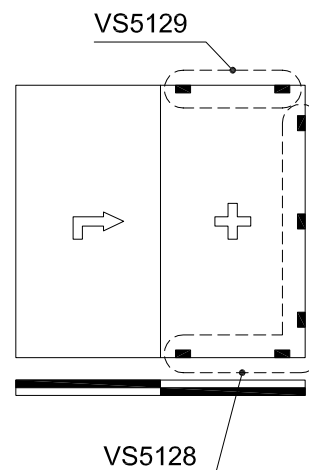

**AGGIUSTAMENTI**

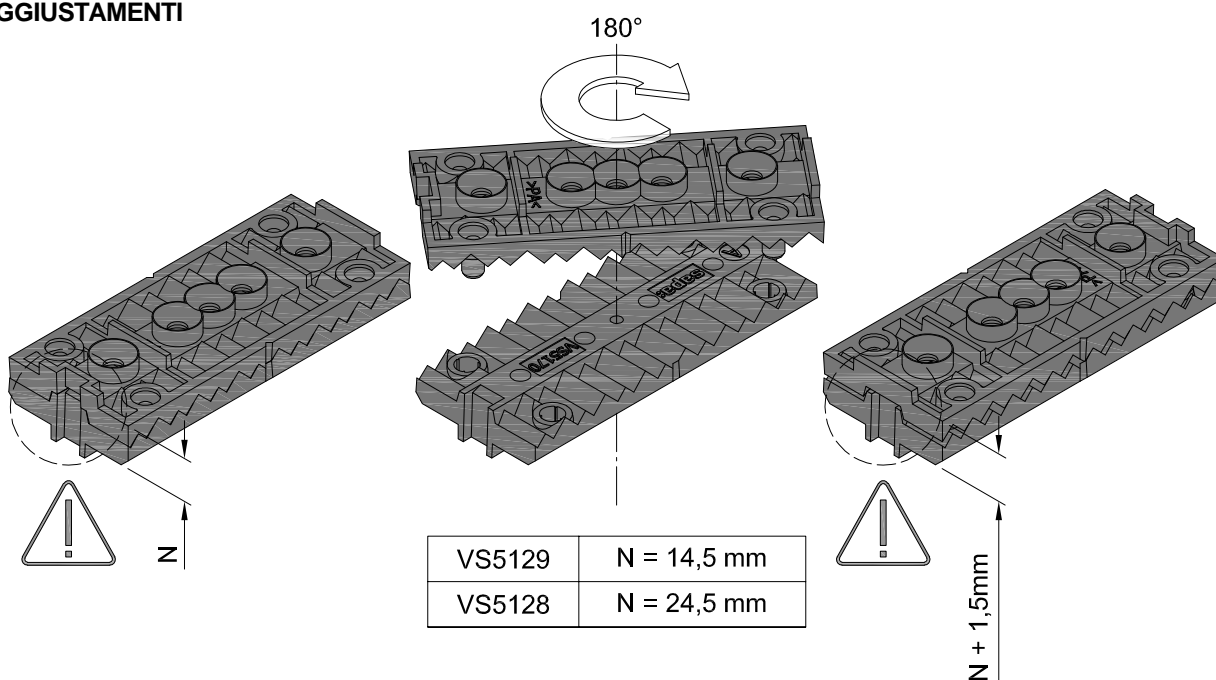

 **C160-ASS-2288L**

## INSTALLAZIONE ANTE SU TELAI

### ANTA FISSA SCORREVOLE-FISSO - ASSEMBLAGGIO VS5128 E BT6015

2 / 10

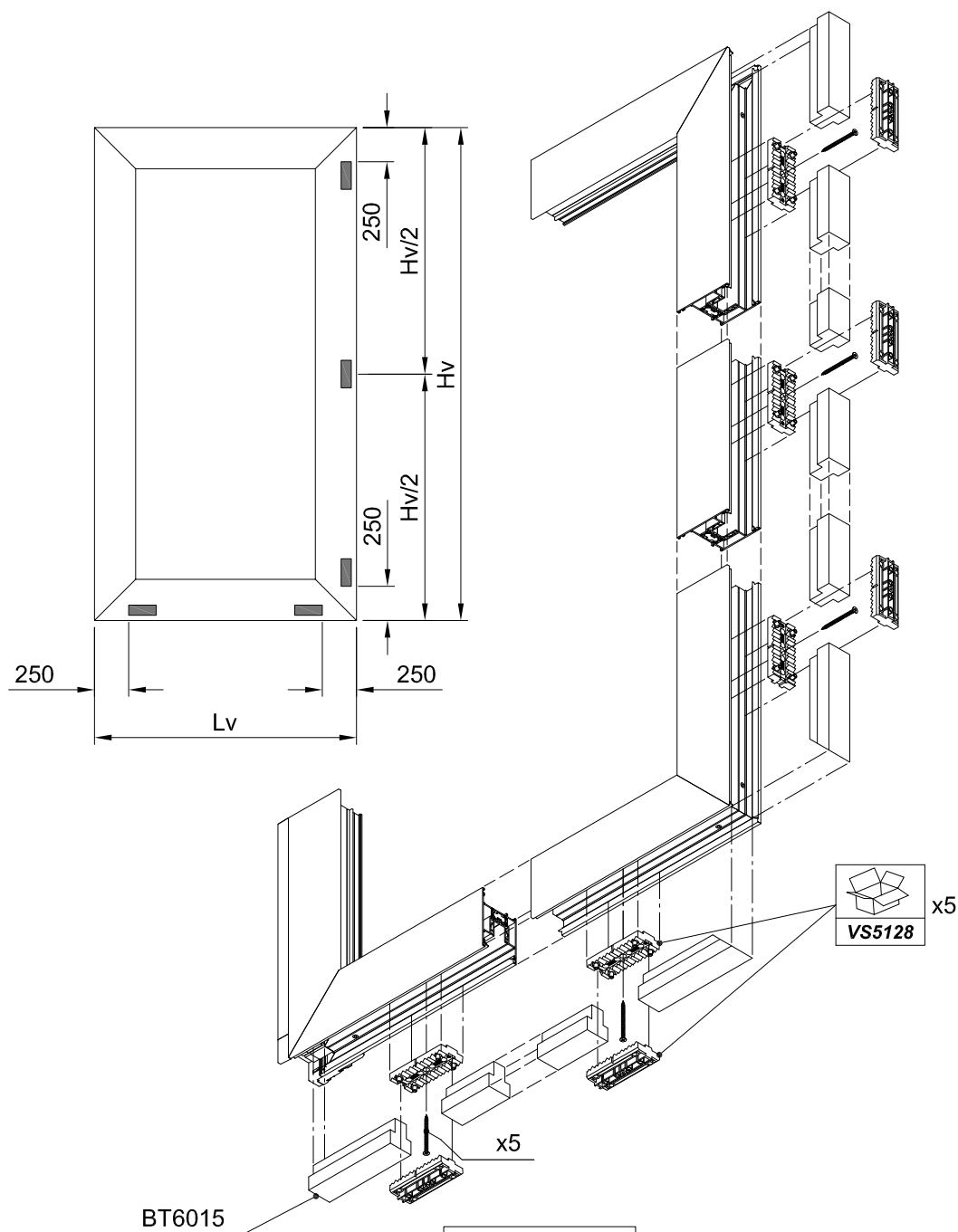
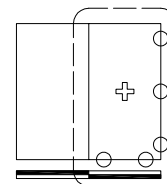

BT6015

	BT6015
SHI	✓
SI	✓
I	x

C160-ASS-2241L

**ANTA FISSA SCORREVOLE-FISSO - FORI PER GUIDE**

3 / 10

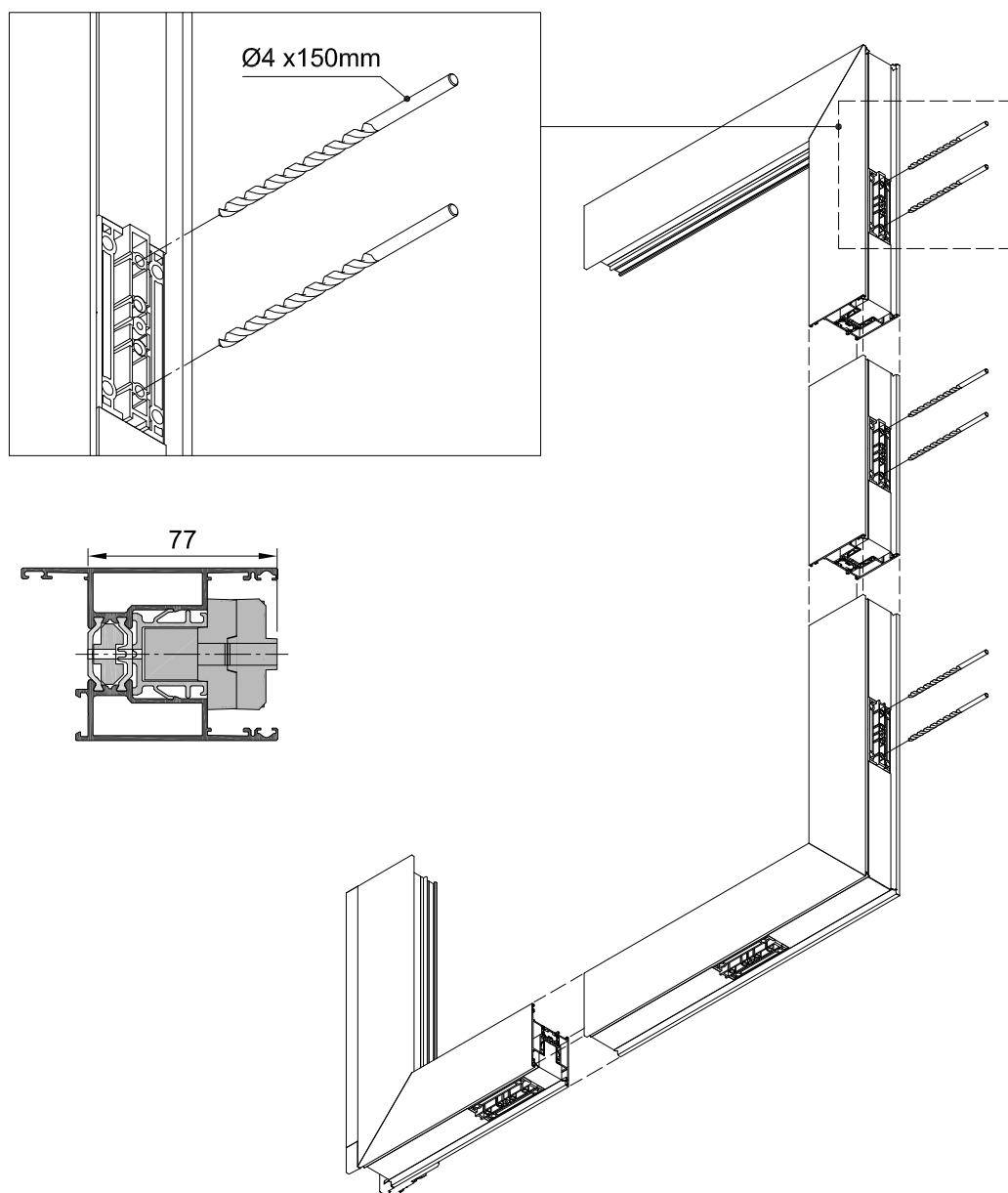
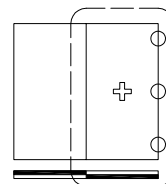



### SCORREVOLE-FISSO - VS5129 E BT6026

4 / 10

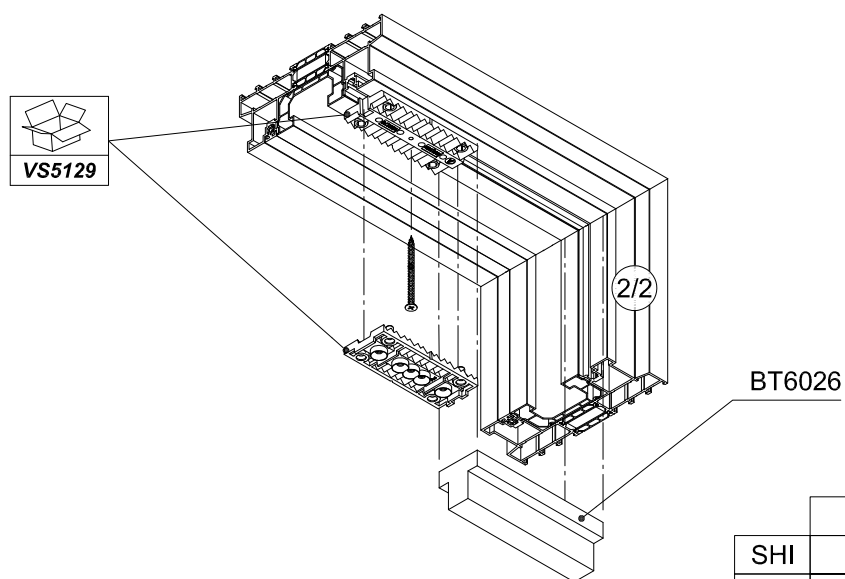
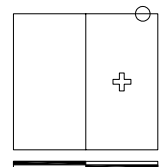
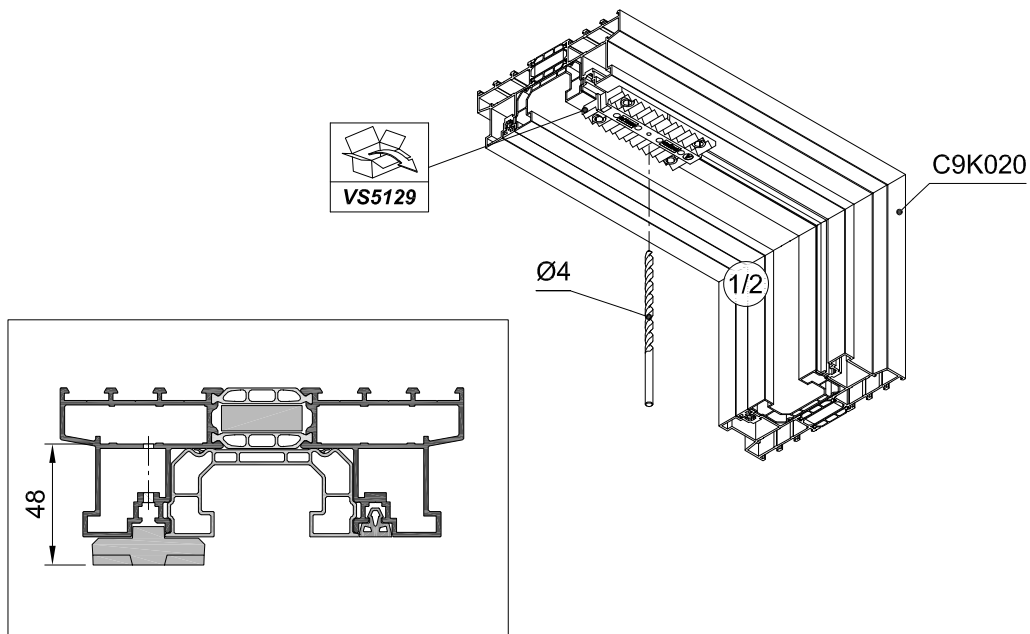
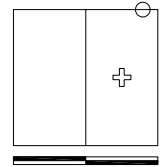

	BT6026
SHI	✓
SI	✓
I	x

**SCORREVOLE-FISSO - ASSEMBLAGGIO ANTA FISSA SU TELAI**

5 / 10

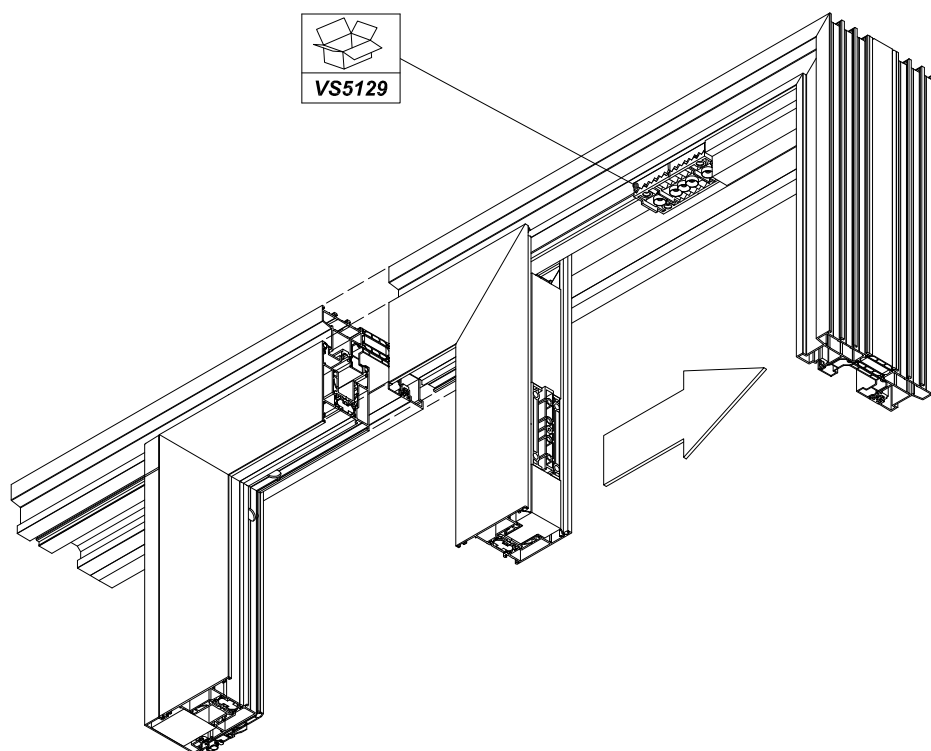
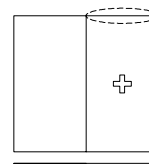
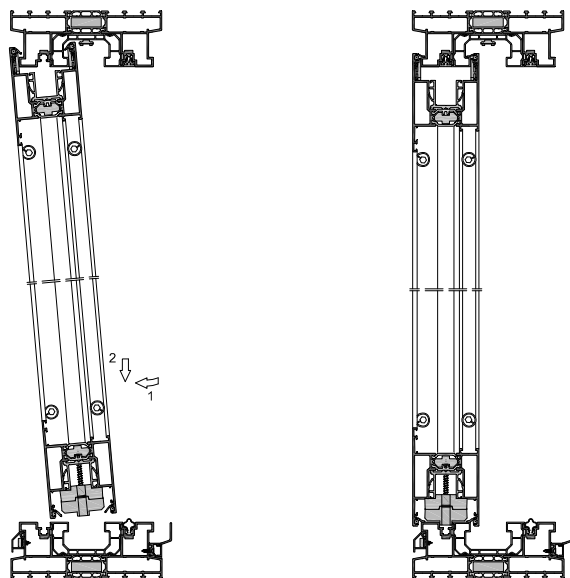
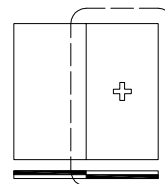

 **C160-ASS-2244L**

### SCORREVOLE-FISSO - RIMOZIONE PROFILATO CARTELLINA

6 / 10

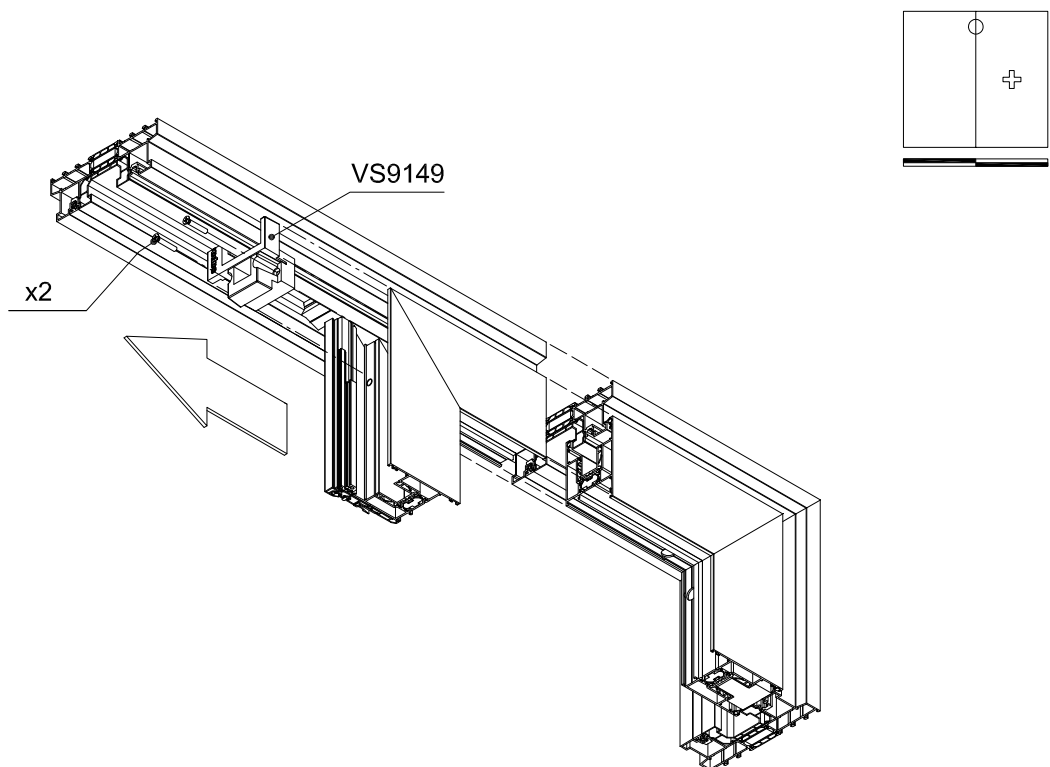
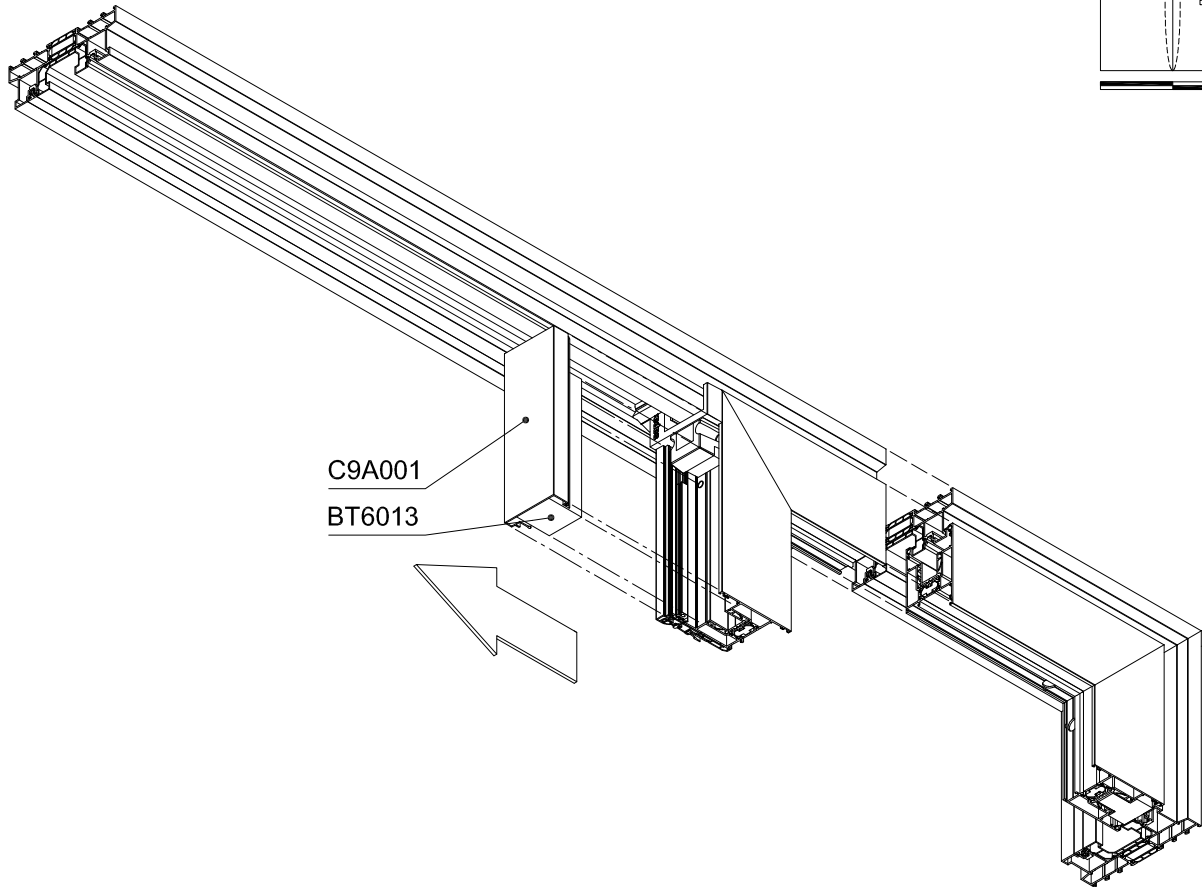

**SCORREVOLE-FISSO - ASSEMBLAGGIO BT6026 E VS5129 SUPERIORE**

7 / 10

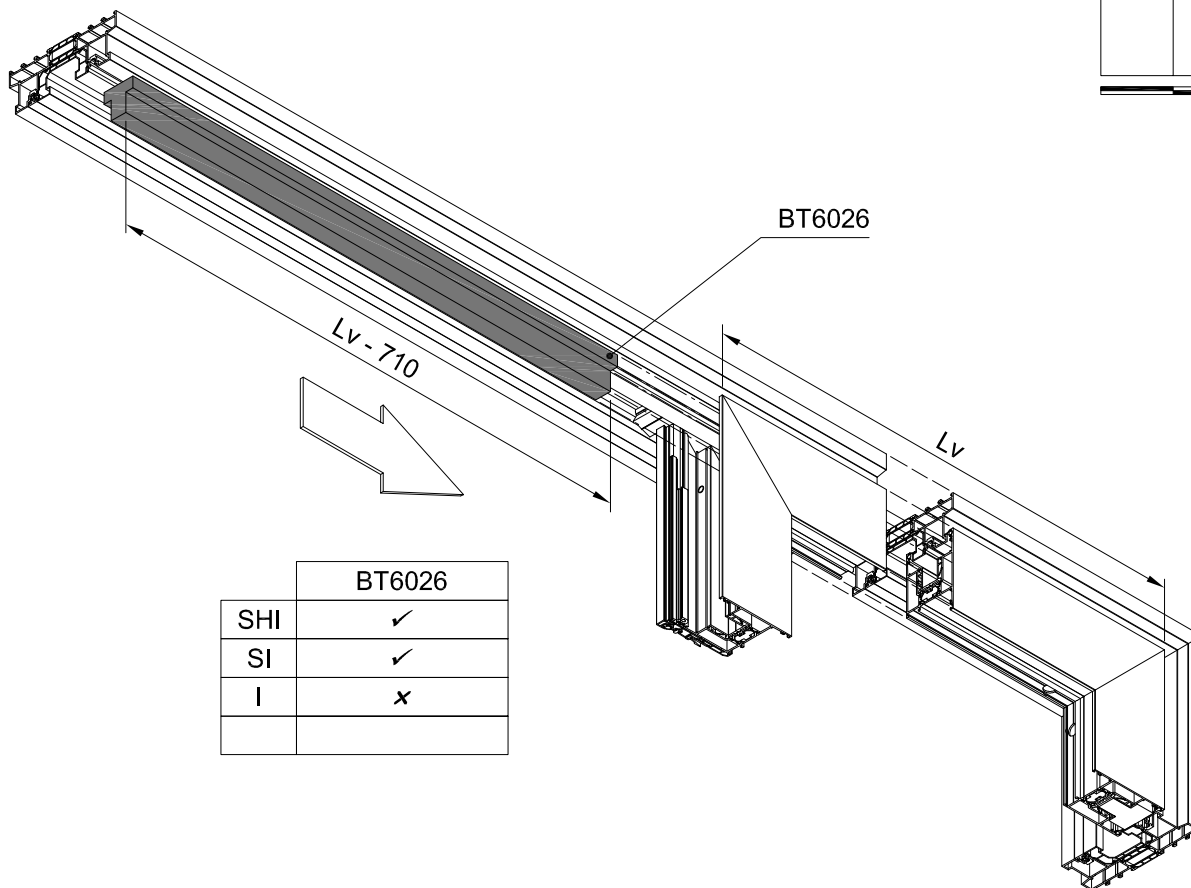
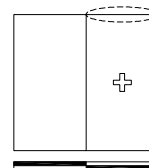

	BT6026
SHI	✓
SI	✓
I	x

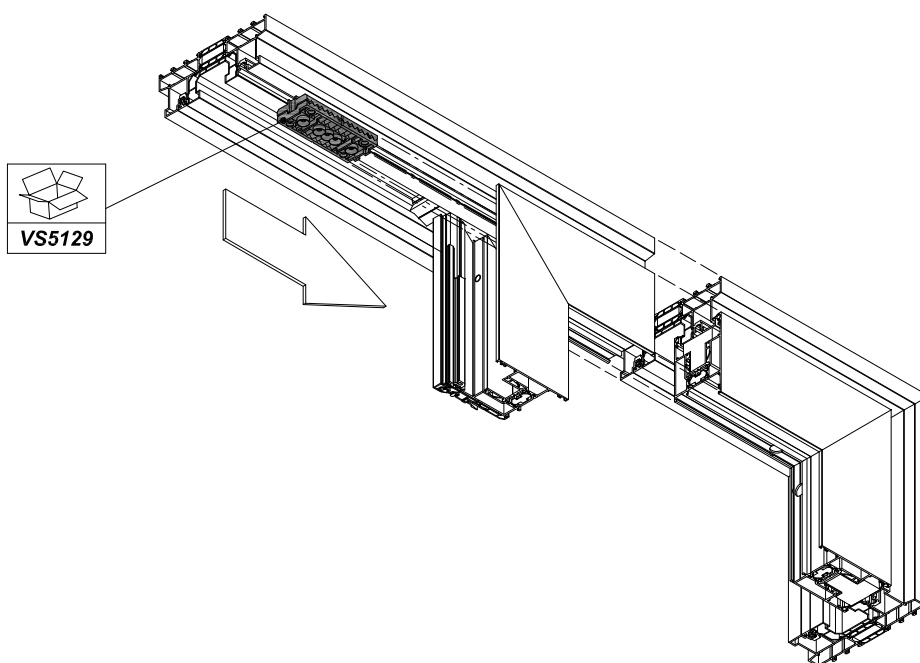
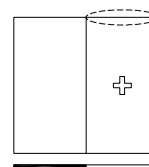

 **C160-ASS-2246L**

### SCORREVOLE-FISSO - FISSAGGIO CON SCZ617

8 / 10

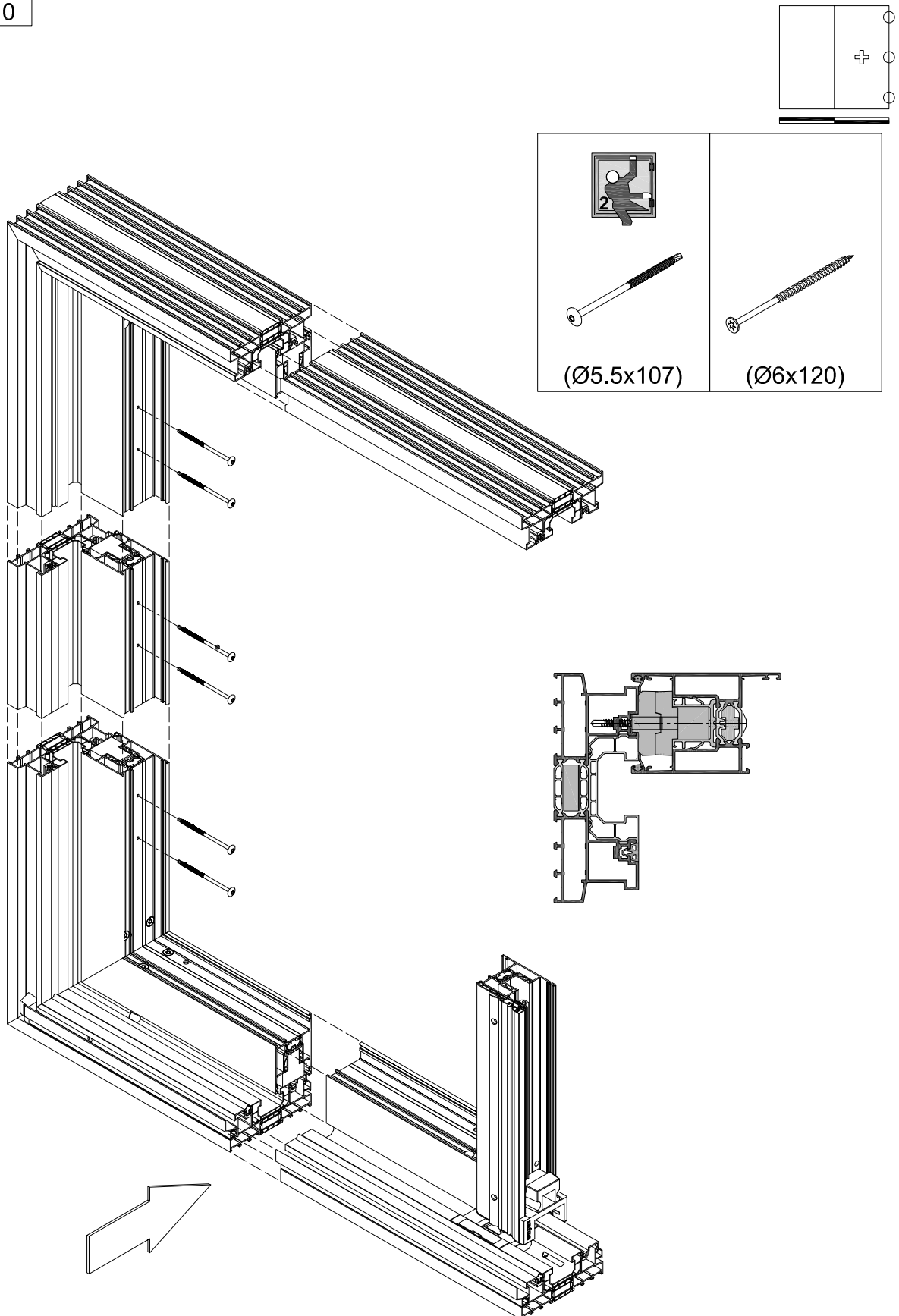



 C160-ASS-2247

**SCORREVOLE-FISSO - FISSAGGIO CON SCZ617**

9 / 10

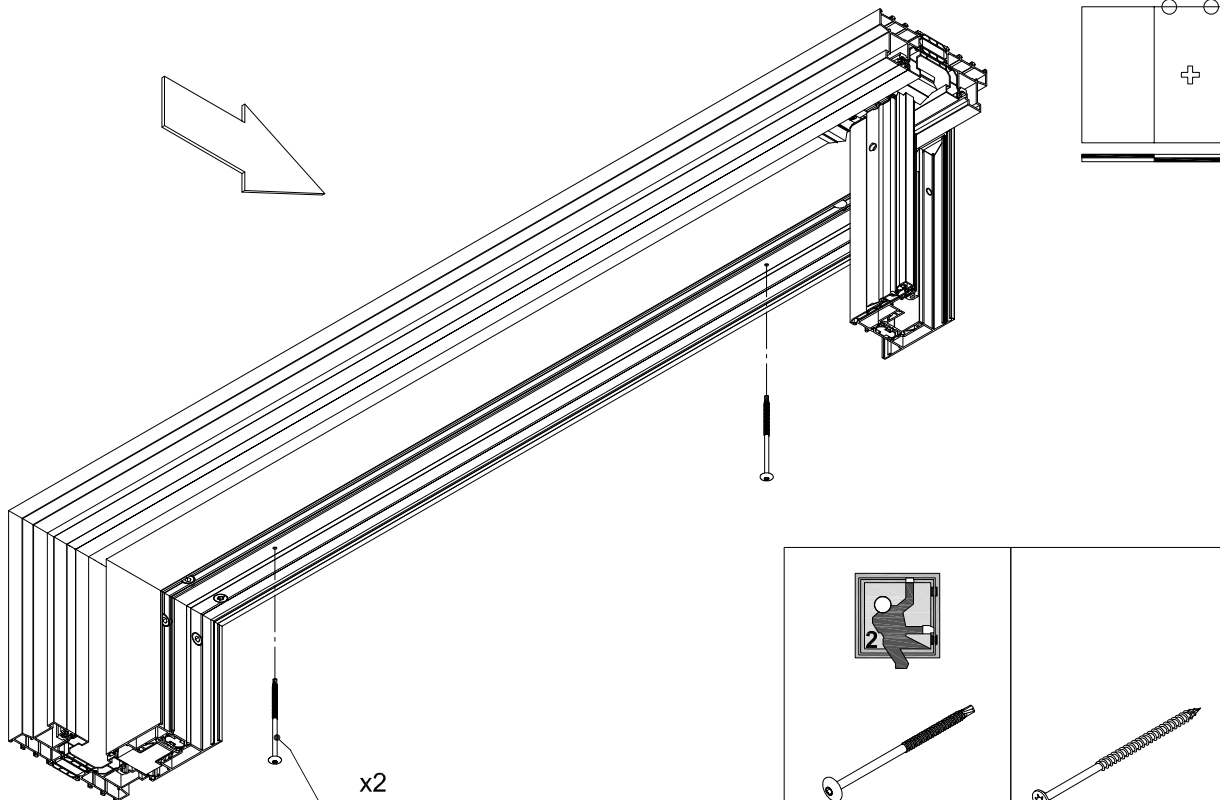
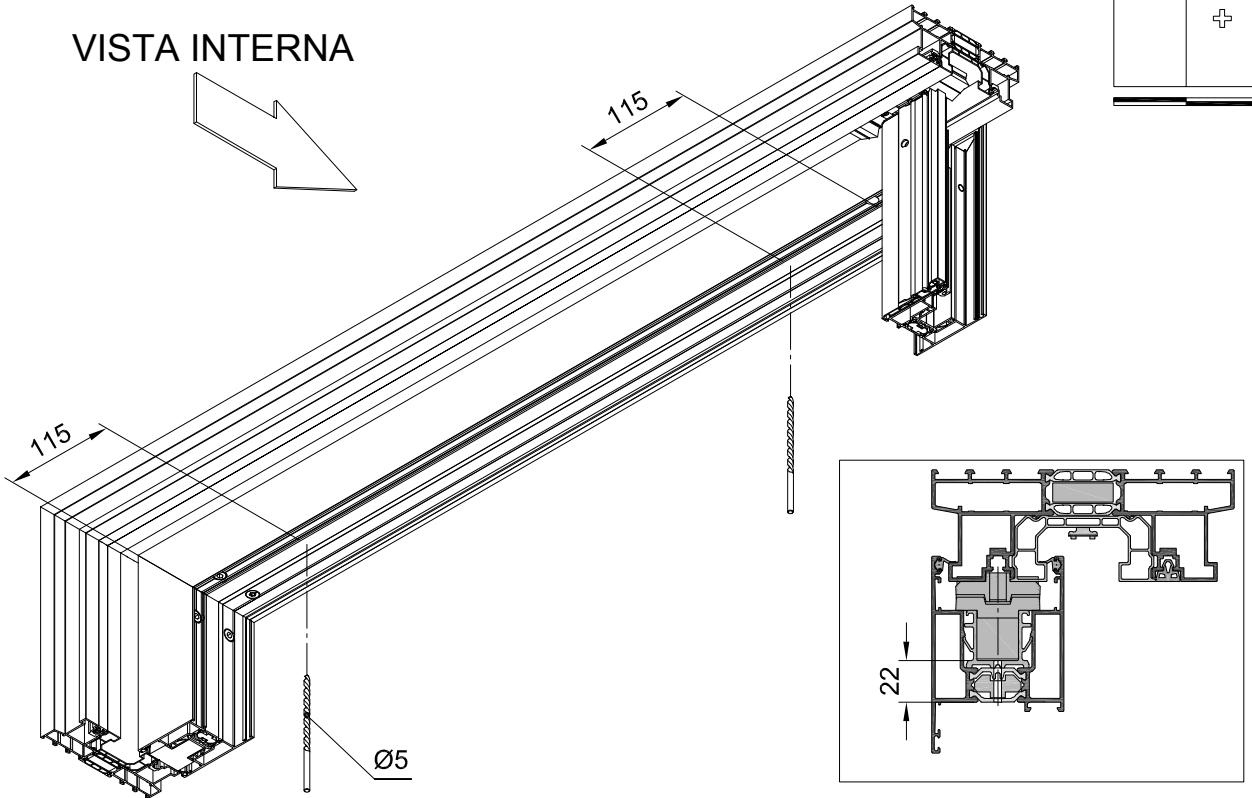
VISTA INTERNA



 **C160-ASS-2248**

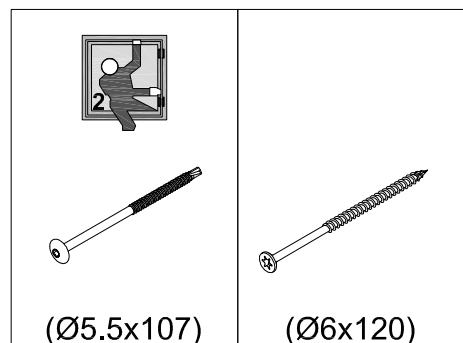

## INSTALLAZIONE ANTE SU TELAI

### SCORREVOLE-FISSO - BASE TAPPO DI TENUTA E CARTELLINA ANTA

10 / 10

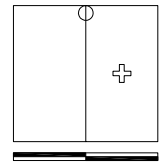
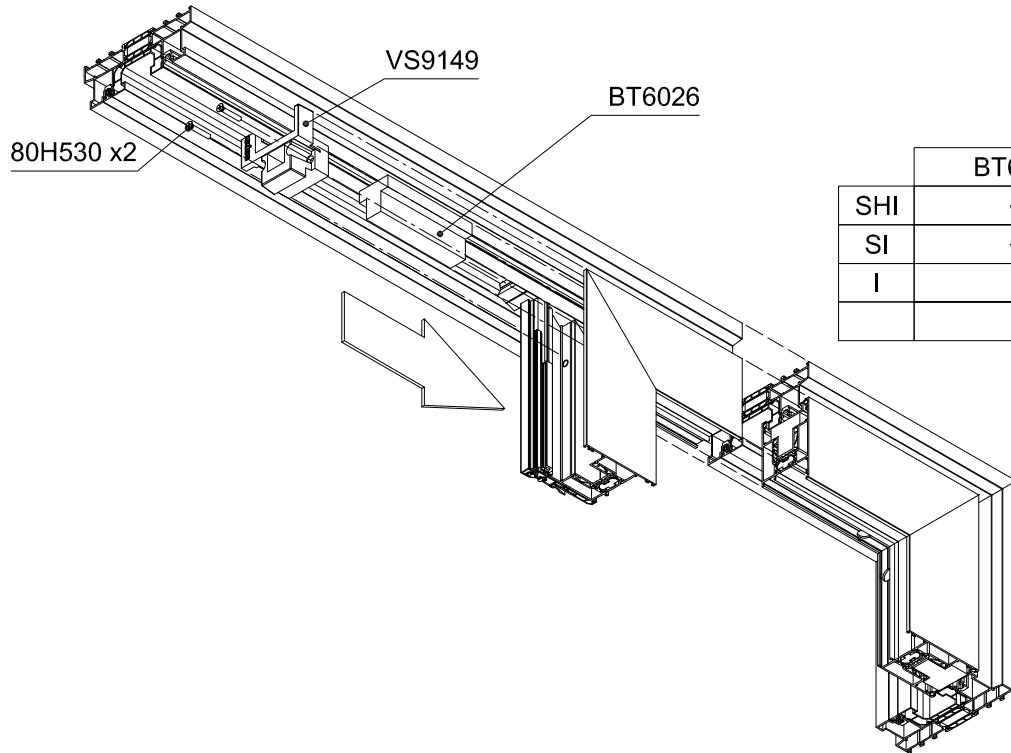

	BT6026
SHI	✓
SI	✓
I	x

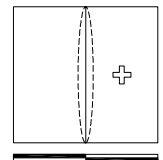
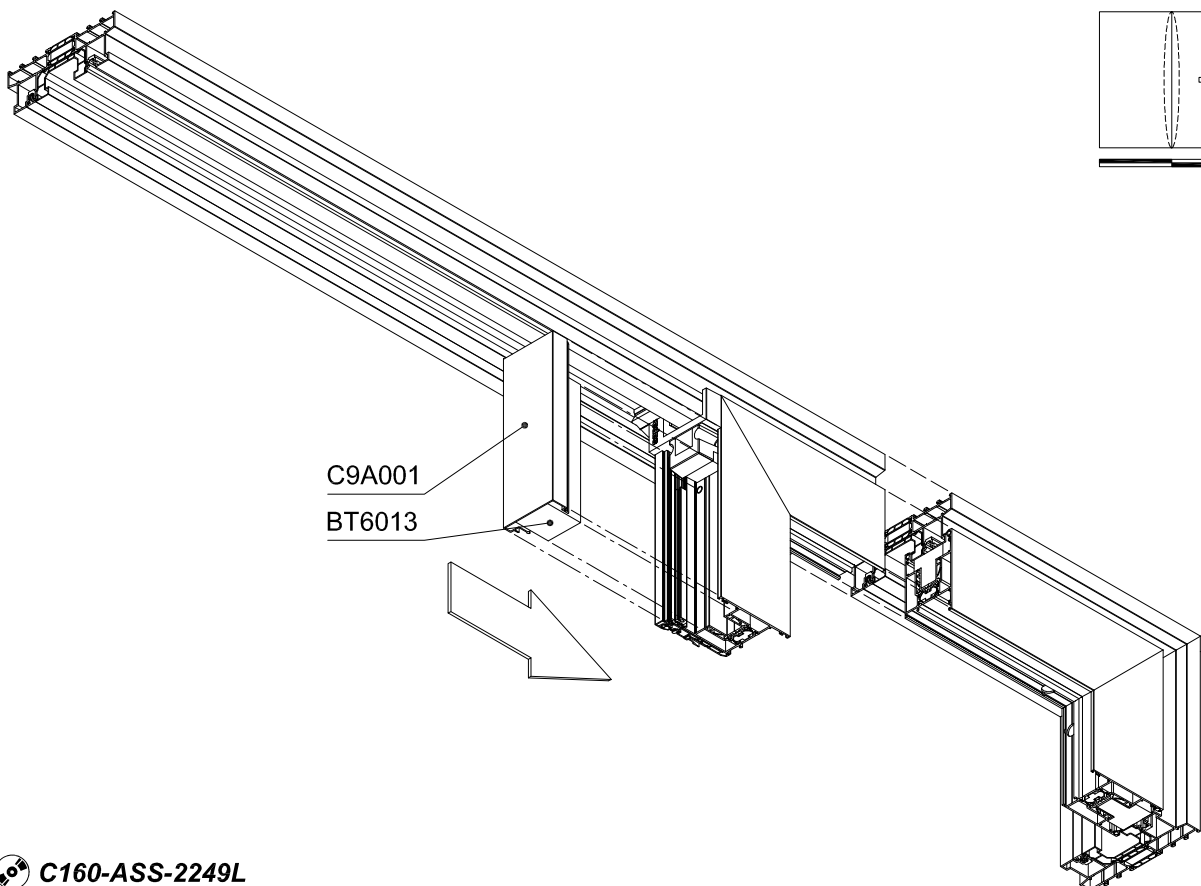

 C160-ASS-2249L

**SCORREVOLE-FISSO - POSIZIONAMENTO ANTA APRIBILE SUL TELAI**

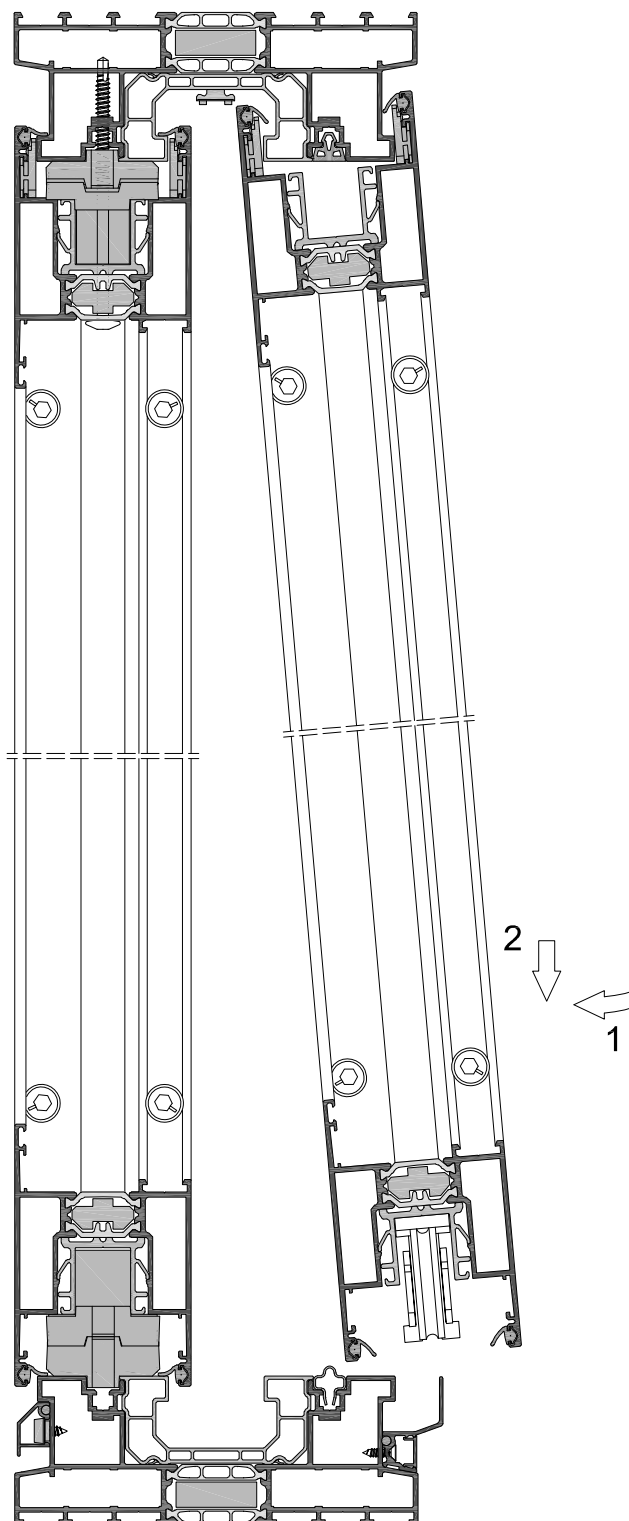
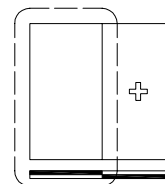



### ASSEMBLAGGIO TAPPO DI TENUTA SUPERIORE- 2-BINARI TELAI

1 / 2

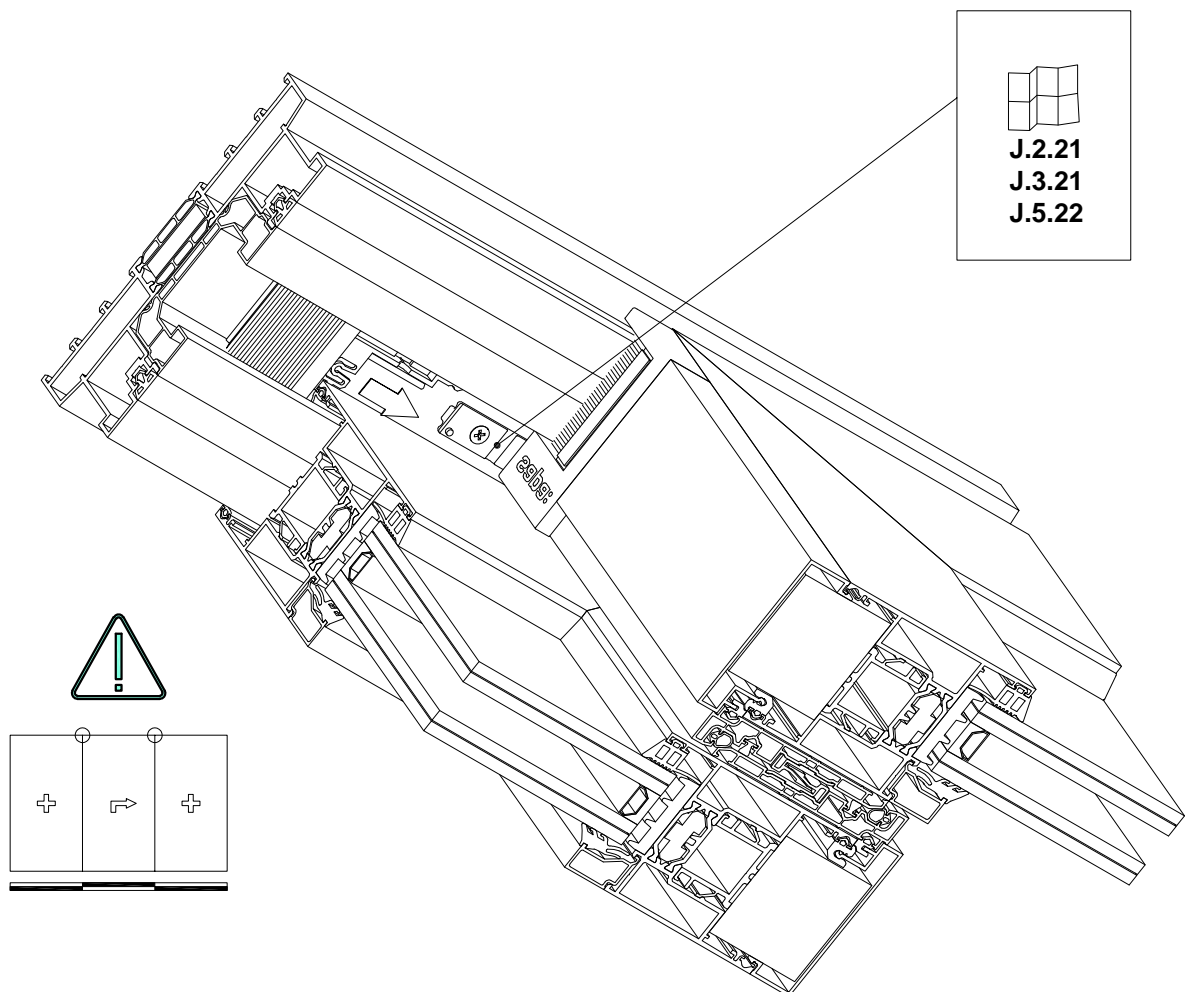
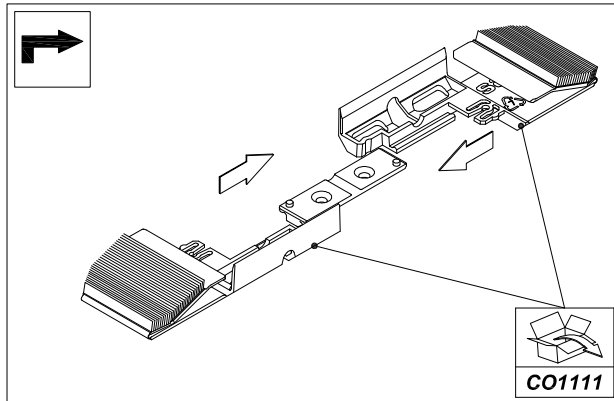
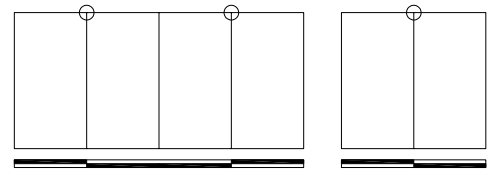

**ASSEMBLAGGIO TAPPO DI TENUTA SUPERIORE- 3-BINARI TELAI**

2 / 2

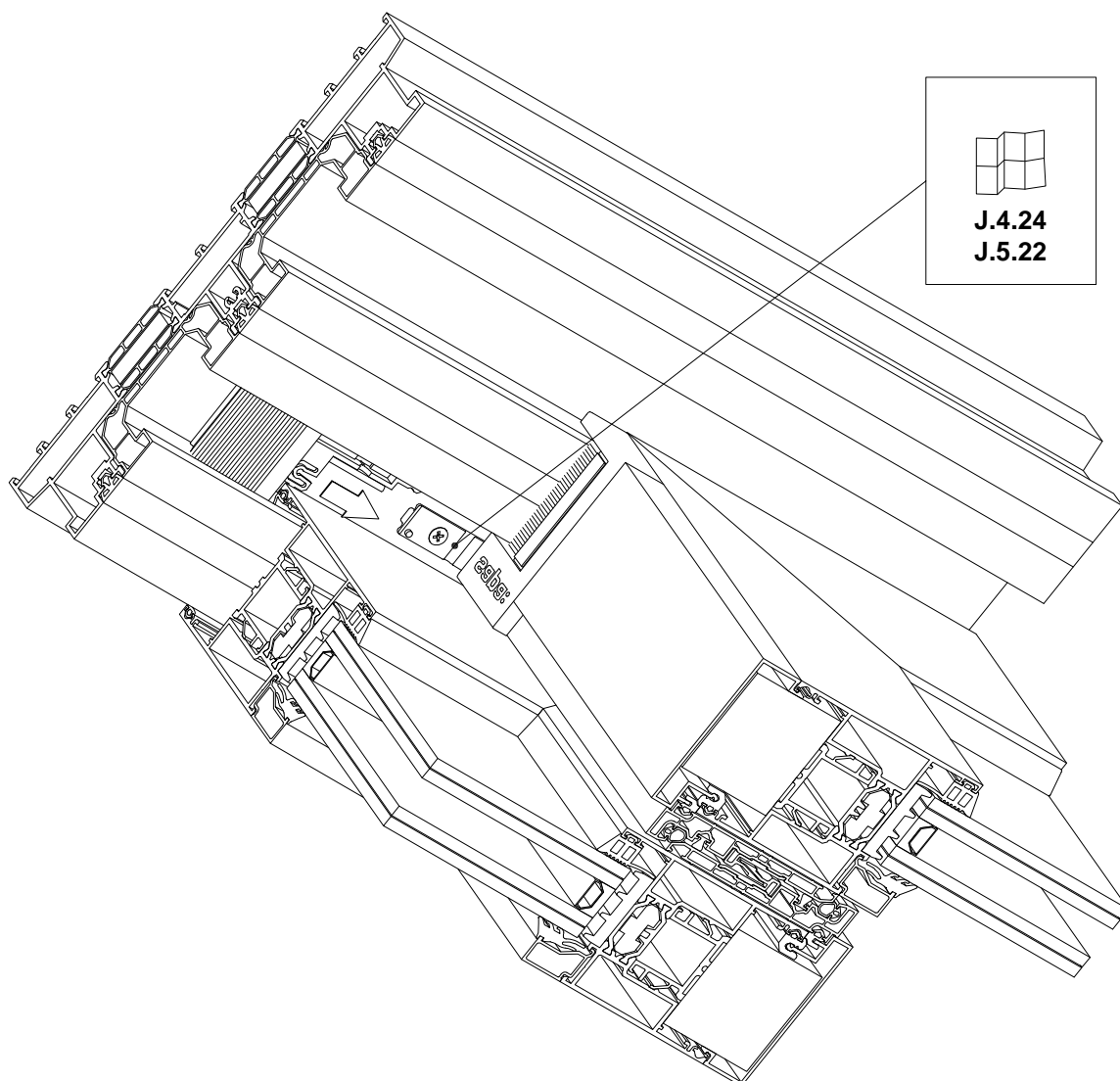
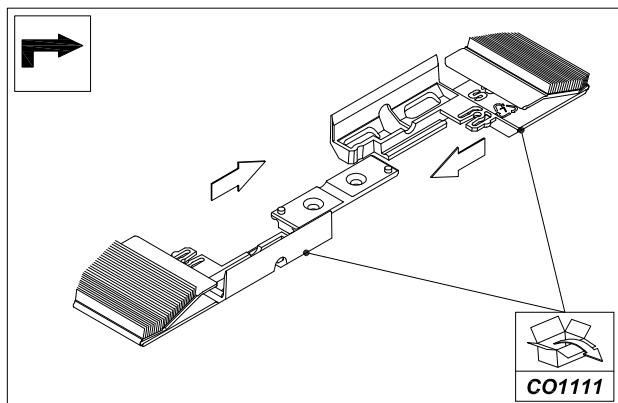
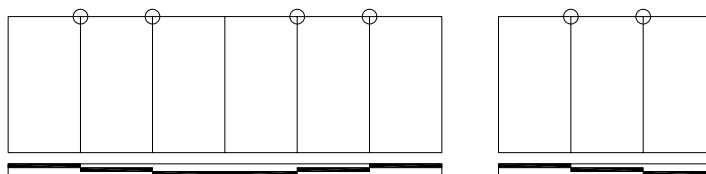

**ASSEMBLAGGIO SV9002**

C9V001+KU2027
C9V051+KU2027
C9V004

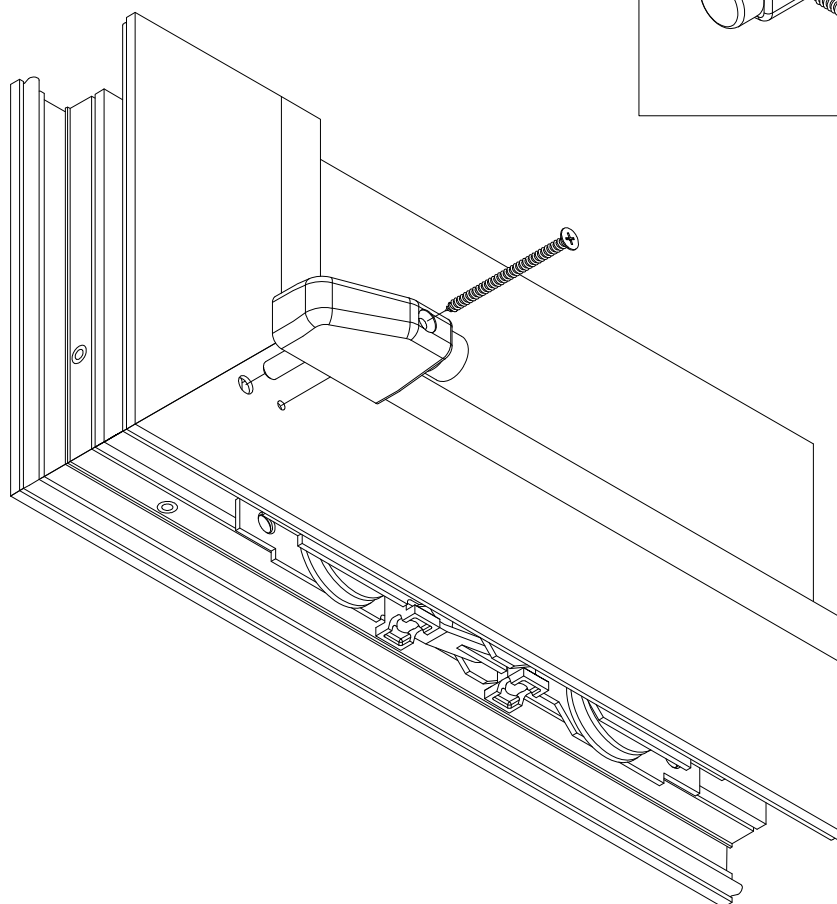
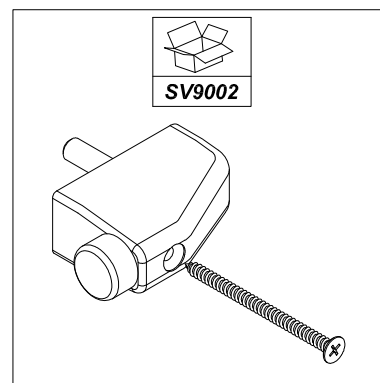
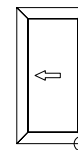
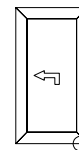



### **CONTENUTO**

Operazioni finitura ante.....	J.13.1
Contenuto.....	J.13.1
Anta passiva schema 4 ante - tappo di tenuta.....	J.13.2
Anta passiva schema 4 ante - fissaggio tappo di tenuta.....	J.13.3
Anta passiva schema 4 ante - posizionamento incontri di chiusura.....	J.13.4
Anta passiva schema 4 ante - installazione guarnizione di finitura RU9704.....	J.13.5
Inserimento finale tappo di tenuta ante alzante-scorrevole.....	J.13.6
Inserimento finale tappo di tenuta ante alzante-scorrevole - Speciale 3-binari.....	J.13.7
Inserimento finale tappo di tenuta ante alzante-scorrevole - Speciale.....	J.13.8

**ANTA PASSIVA SCHEMA 4 ANTE - TAPPO DI TENUTA**

1 / 2

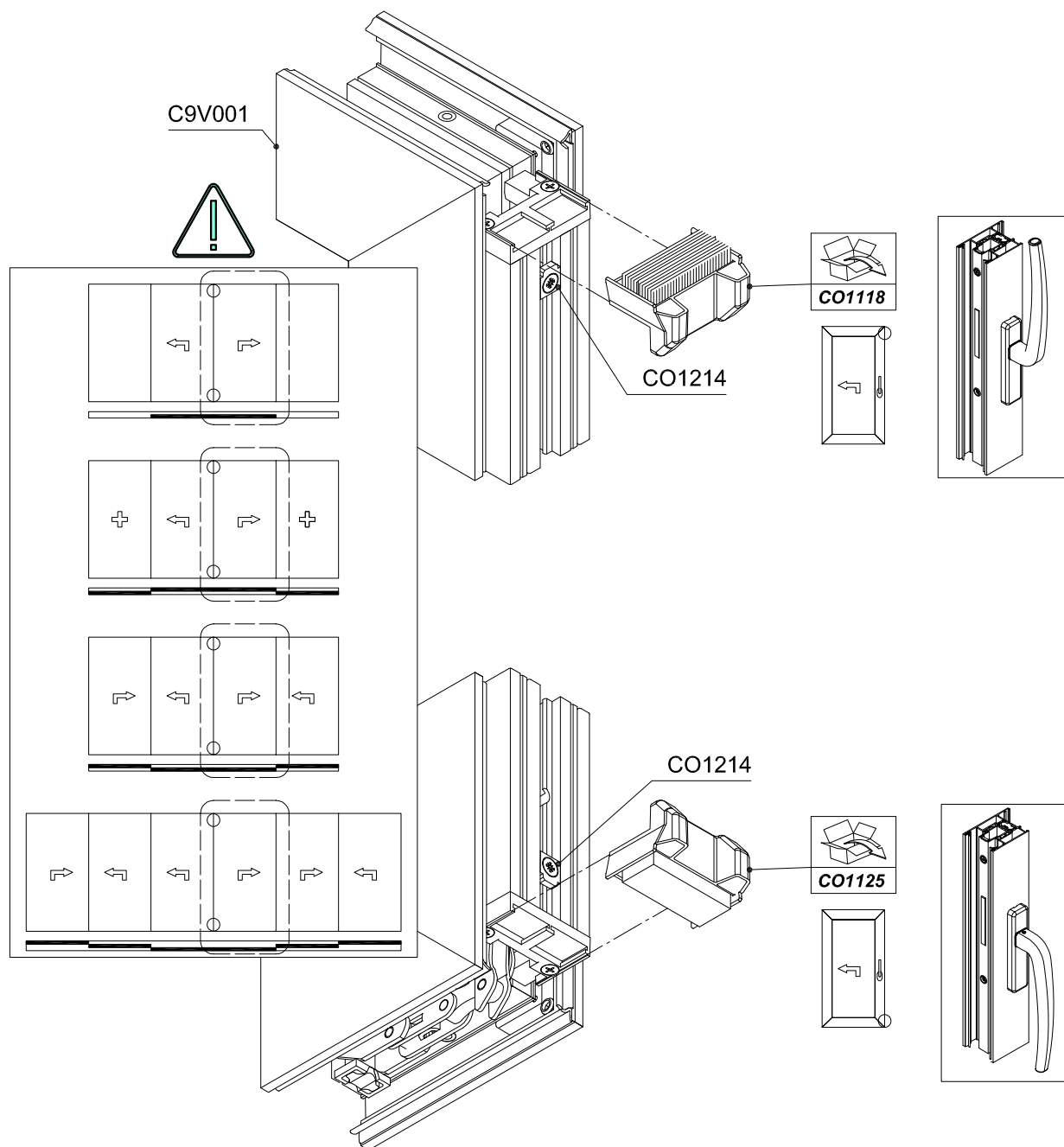
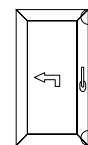

### ANTA PASSIVA SCHEMA 4 ANTE - FISSAGGIO TAPPO DI TENUTA

2 / 2



J.10.26  
J.10.28

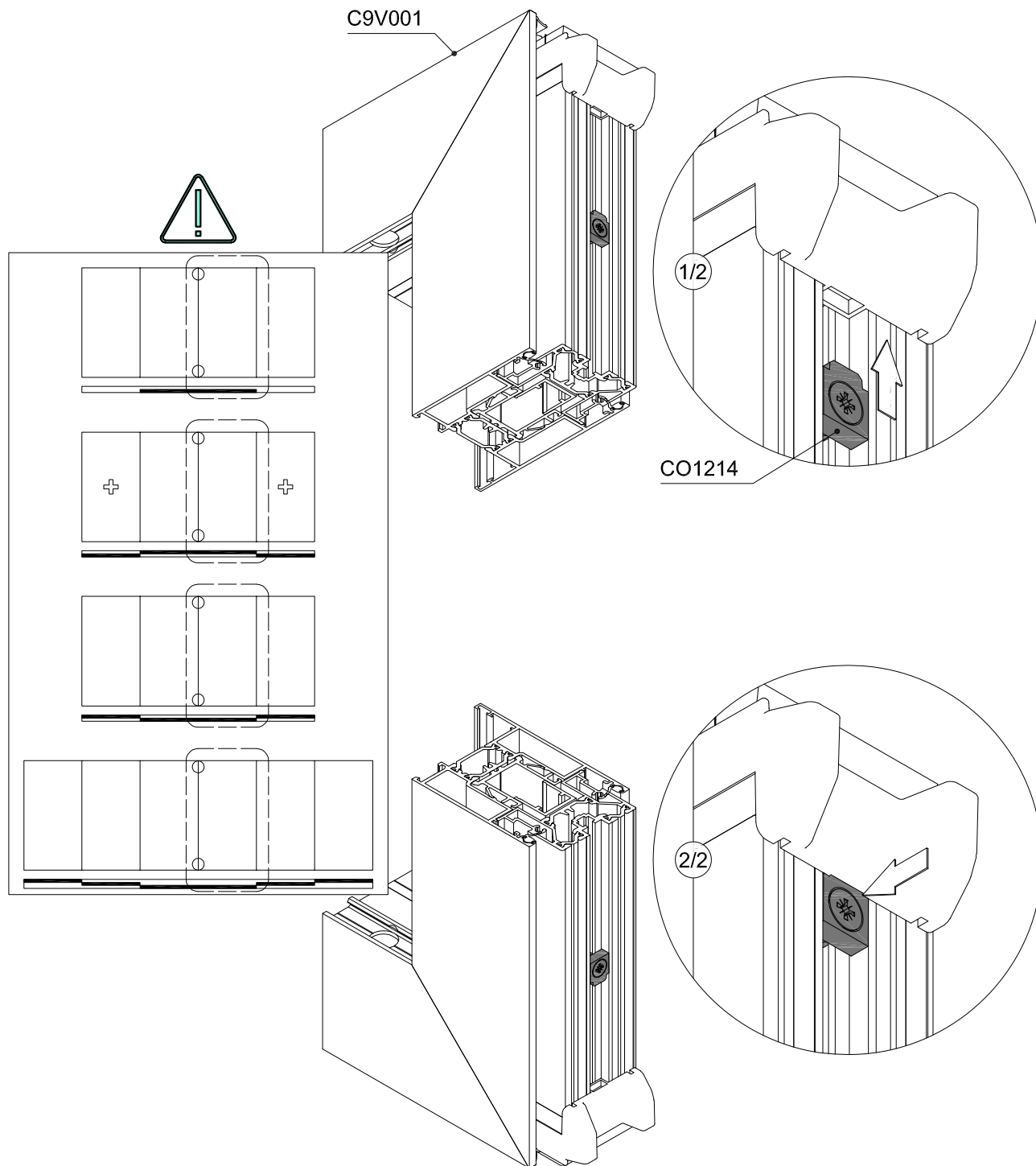
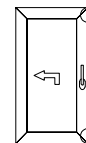

**ANTA PASSIVA SCHEMA 4 ANTE - POSIZIONAMENTO INCONTRI DI CHIUSURA**



J.10.27

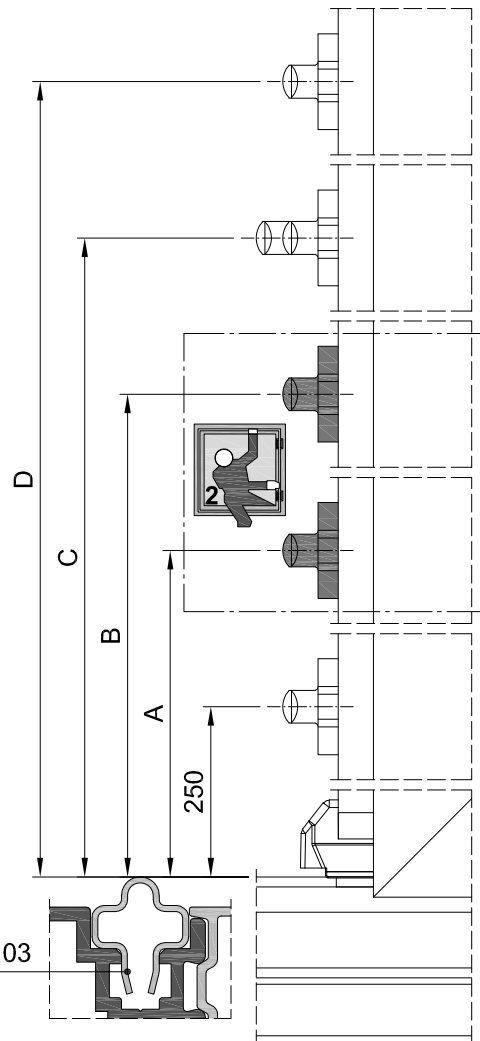
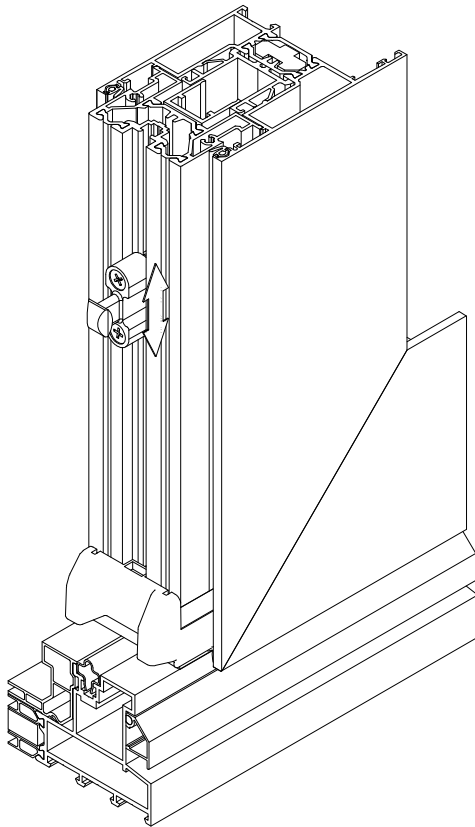
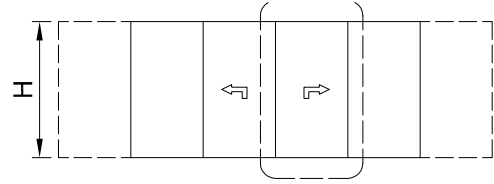

Hv	
H - 100	C9K012 C9K020 C9K021 C9K022 C9K023 C9K030 C9K120/C9K121 C9K130/C9K131
H - 82	C9K010
H - 88	C9K100/C9K120/C9K121

Hv	Hv	ZB0034	A B C D			
			750	1200	1600	1900
	2010 - 2309	ZB0034	750	1200	1600	Hv - 271
	2310 - 2609	ZB0035			1900	
	2610 - 2909	ZB0036			2200	
	2910 - 3209	ZB0035 + ZB0046			1900	
	3210 - 3509	ZB0036 + ZB0046			2200	
	1312 - 2009	ZB0033	600	1000		

 **C160-ASS-2202**



### ANTA PASSIVA SCHEMA 4 ANTE - INSTALLAZIONE GUARNIZIONE DI FINITURA RU9704

C9V001+KU2027
C9V051+KU2027
C9V004

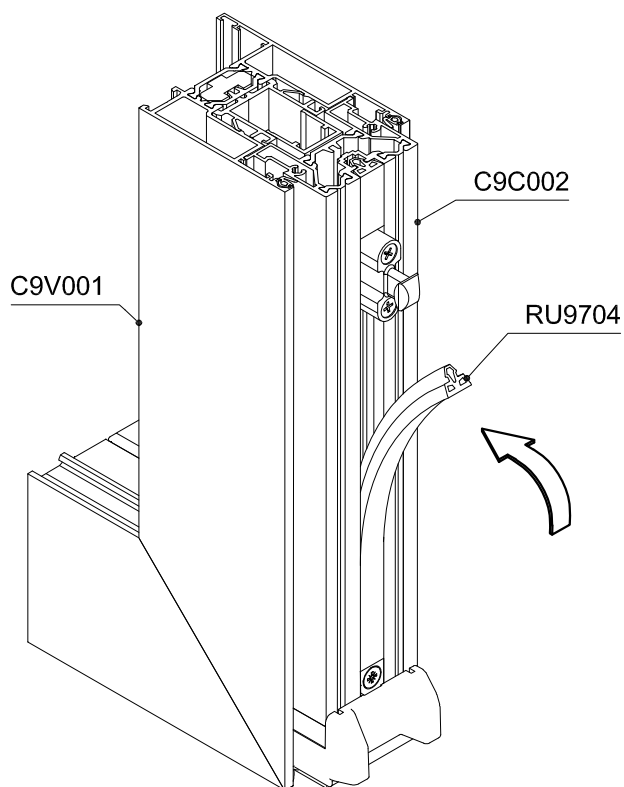
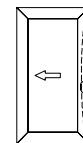
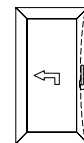

**INSERIMENTO FINALE TAPPO DI TENUTA ANTE ALZANTE-SCORREVOLE**

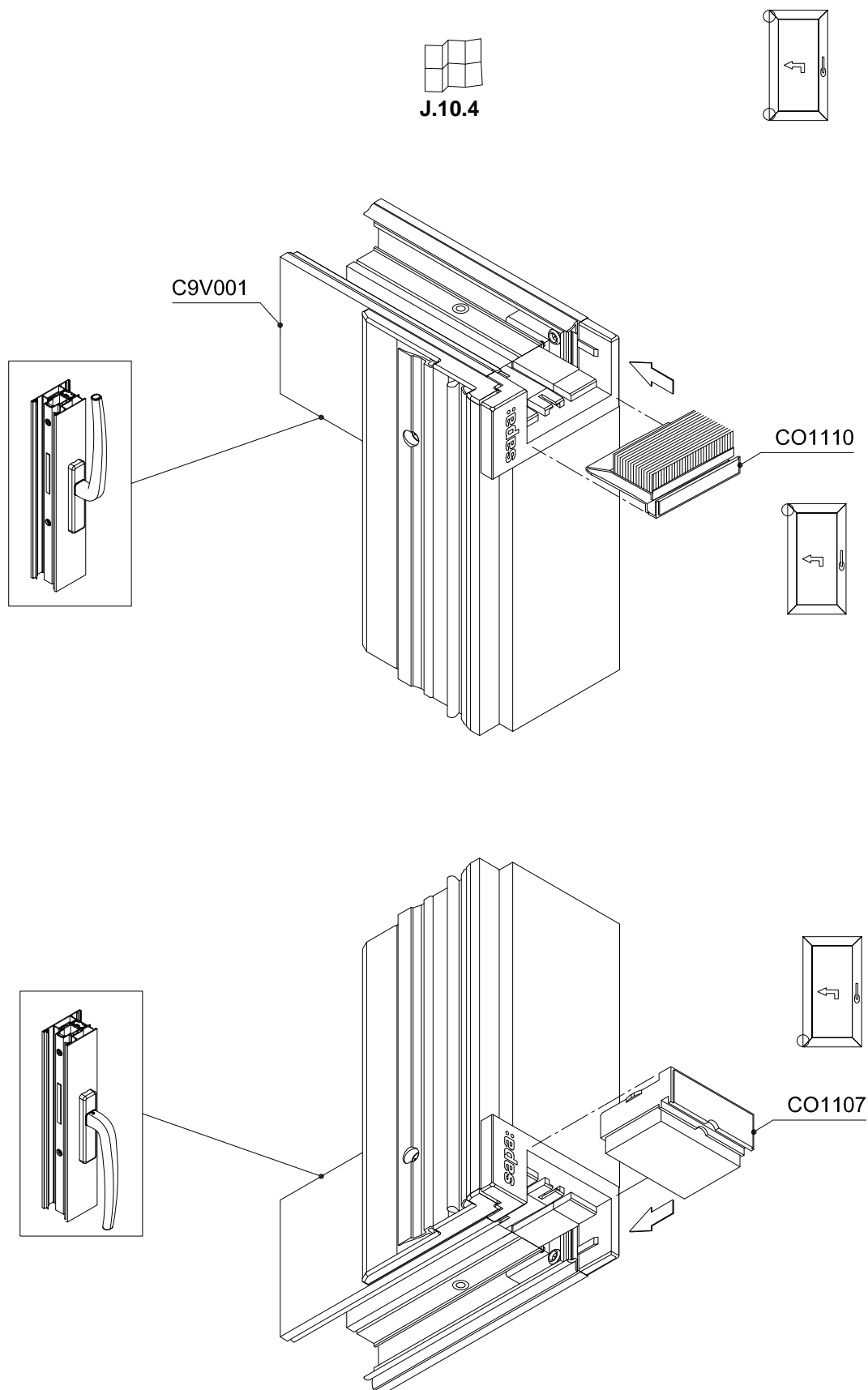

### INSERIMENTO FINALE TAPPO DI TENUTA ANTE ALZANTE-SCORREVOLE - SPECIALE 3-BINARI

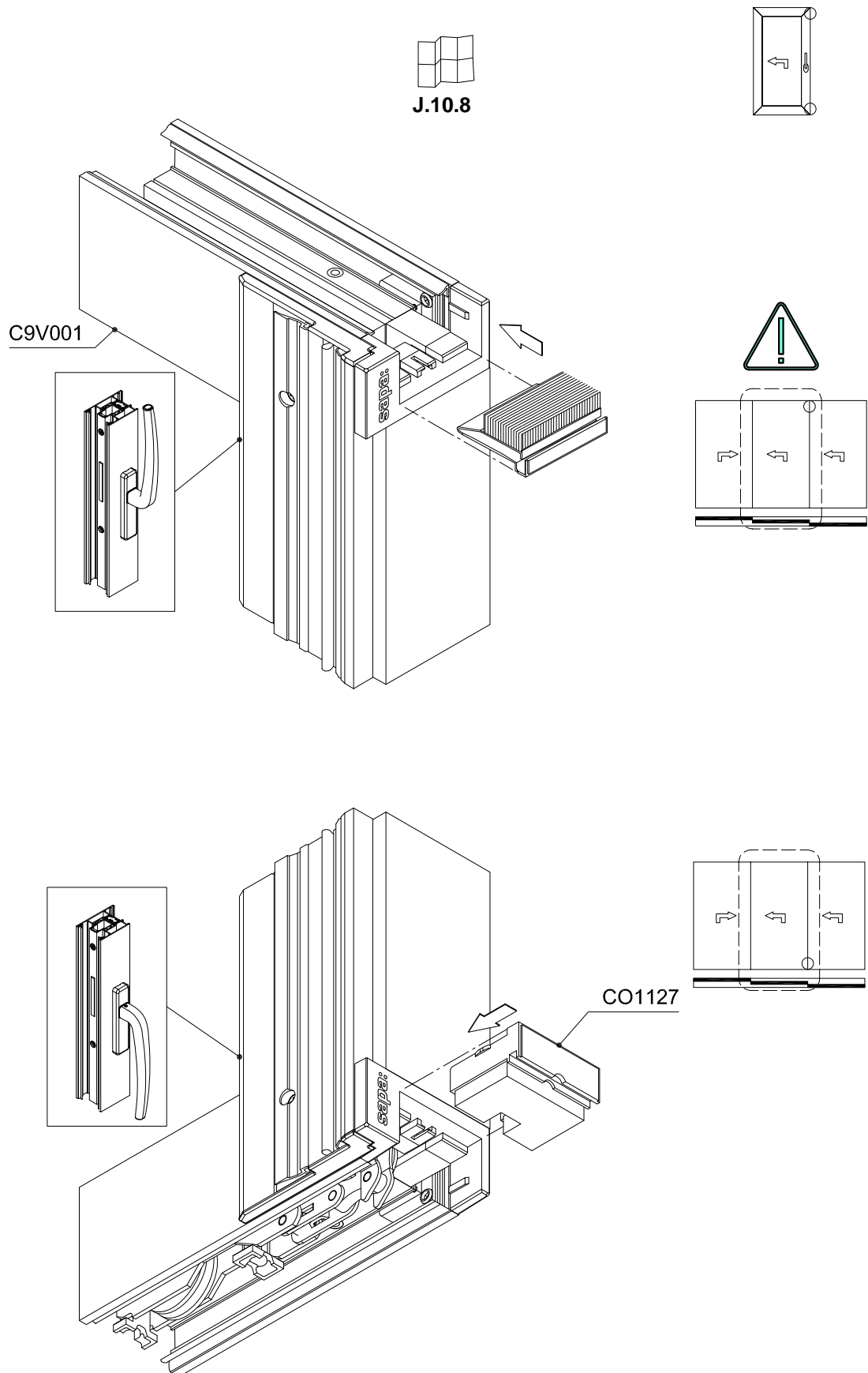

**INSERIMENTO FINALE TAPPO DI TENUTA ANTE ALZANTE-SCORREVOLE - SPECIALE**



**J.10.12**

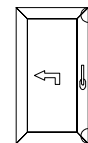

**C9V001**

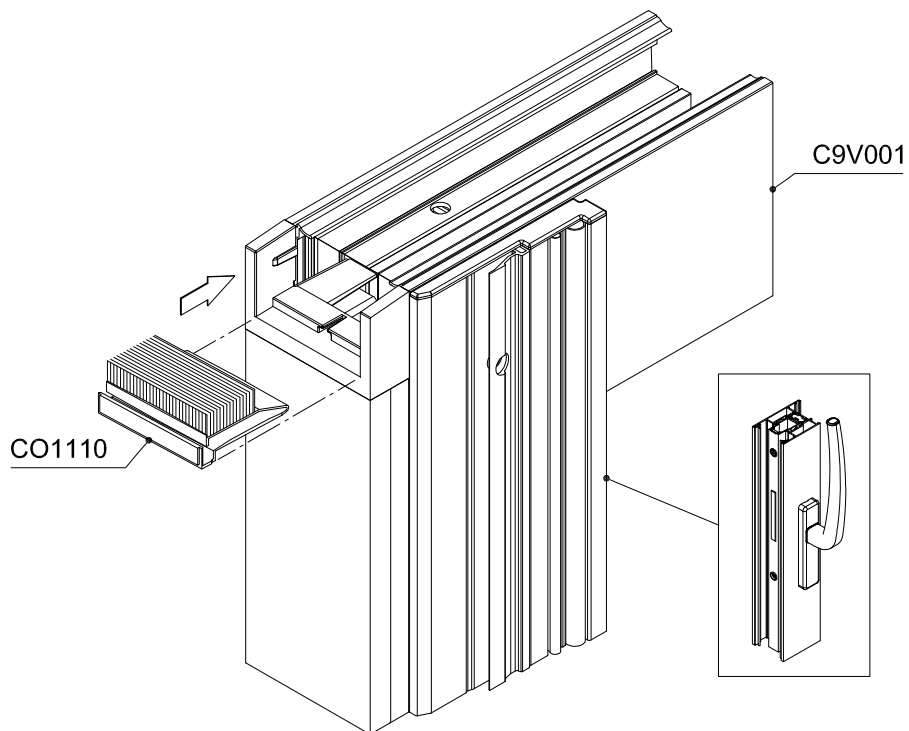
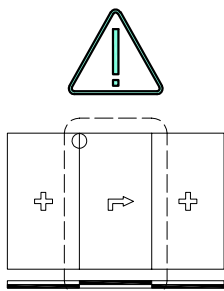

**CO1110**

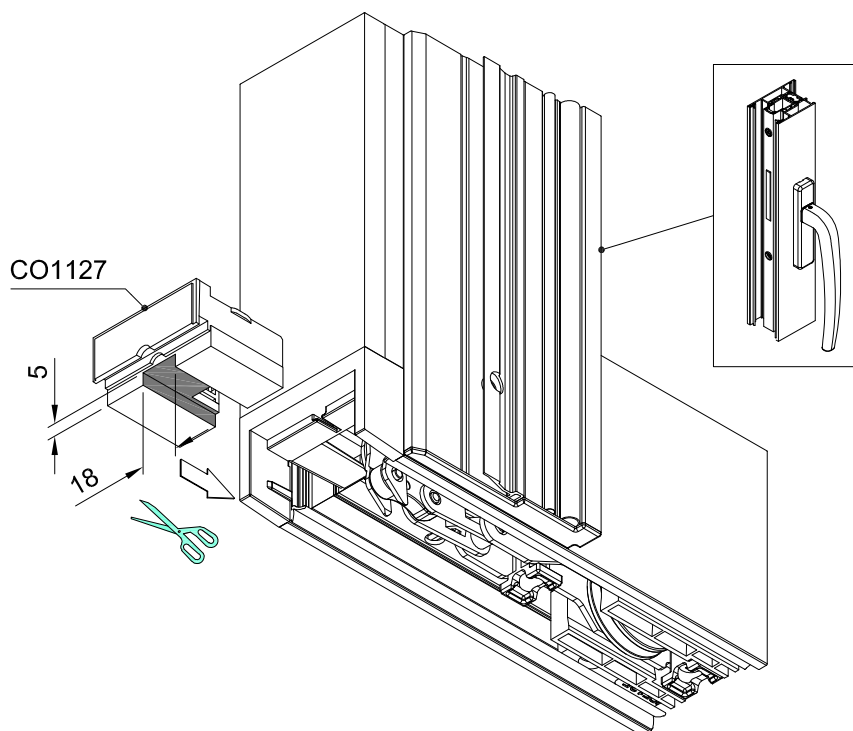
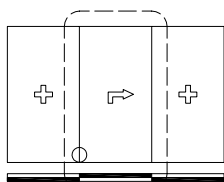

**CO1127**

### ASSEMBLAGGIO SUPPORTI VETRO VS5130

1 / 5

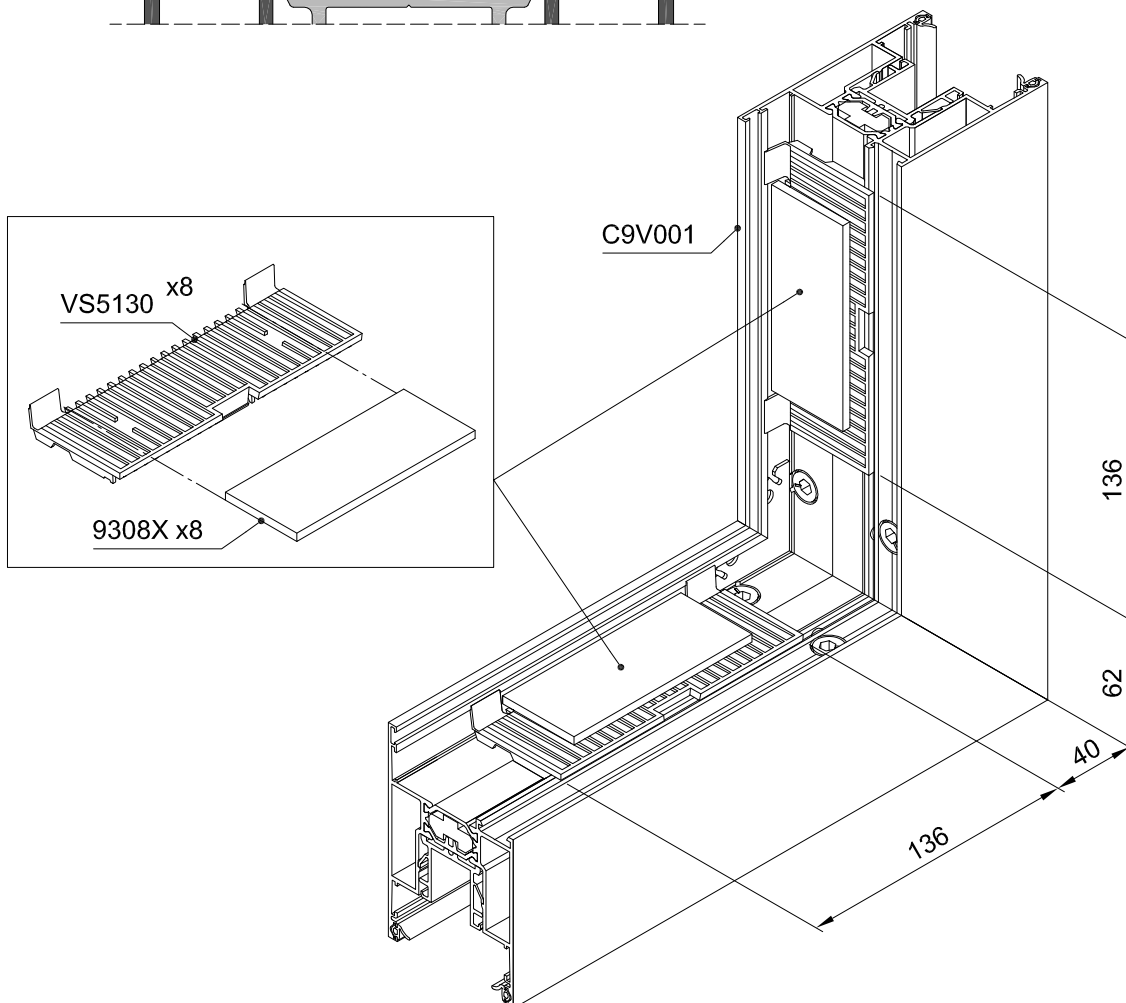
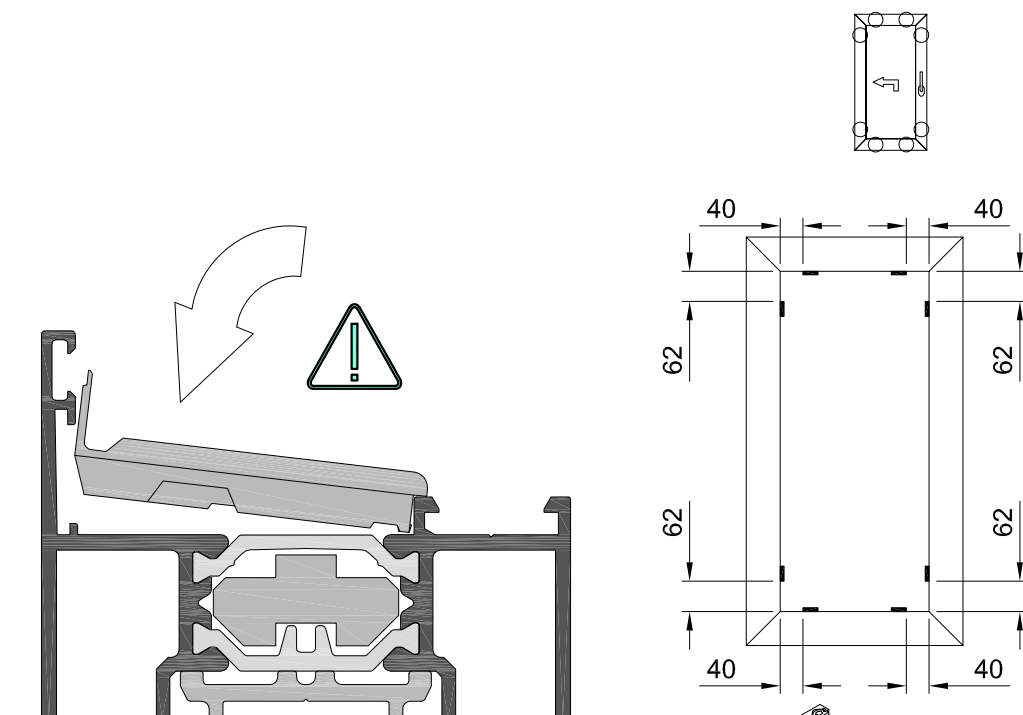

MONTAGGIO FERMAVETRO PER USO CON VS5130

2 / 5

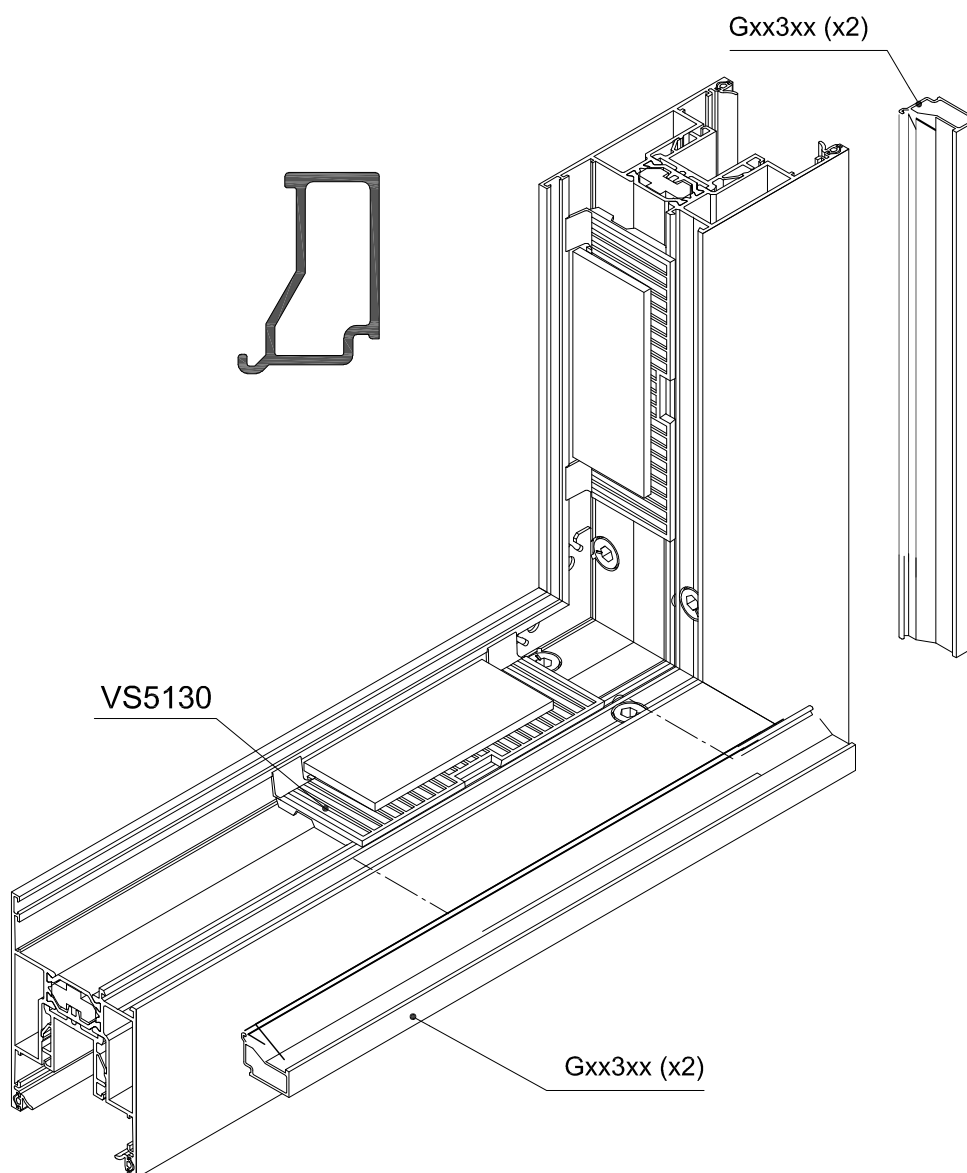
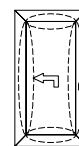

### VETRATURA VERSIONE SHI CON RU0002/RU0004

3 / 5

C9V001+KU2027
C9V051+KU2027

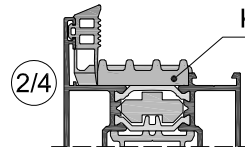
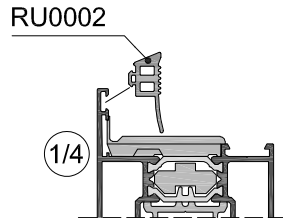
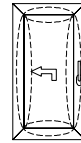

	KU5001
SHI	✓
SI	x
I	x

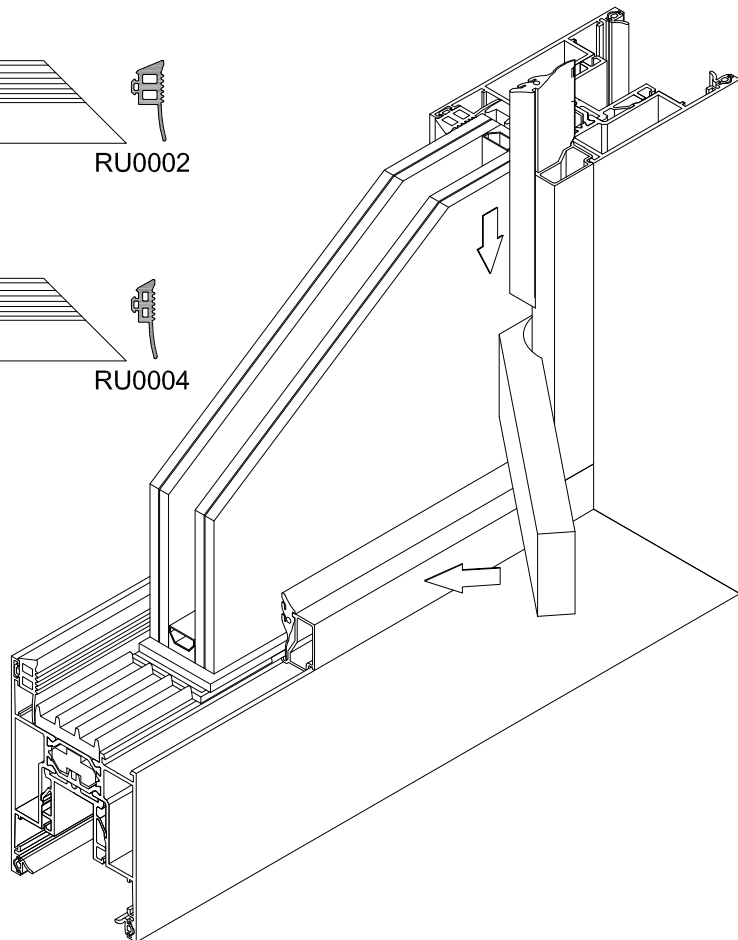
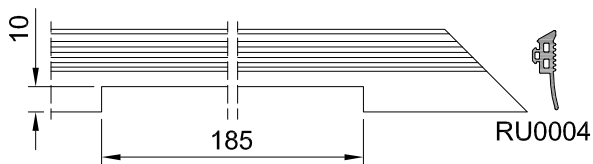
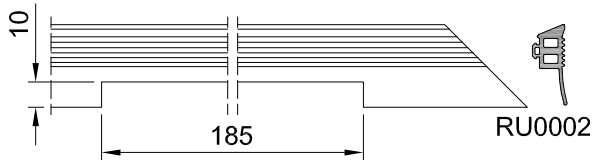
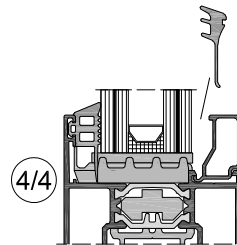
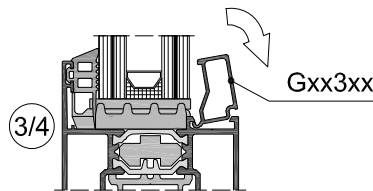

**VETRATURA BASE CON 210-033**

5 / 5

C9V001+KU2027
C9V051+KU2027
C9V004

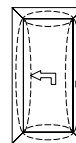

-SH-
-SI-
-I-

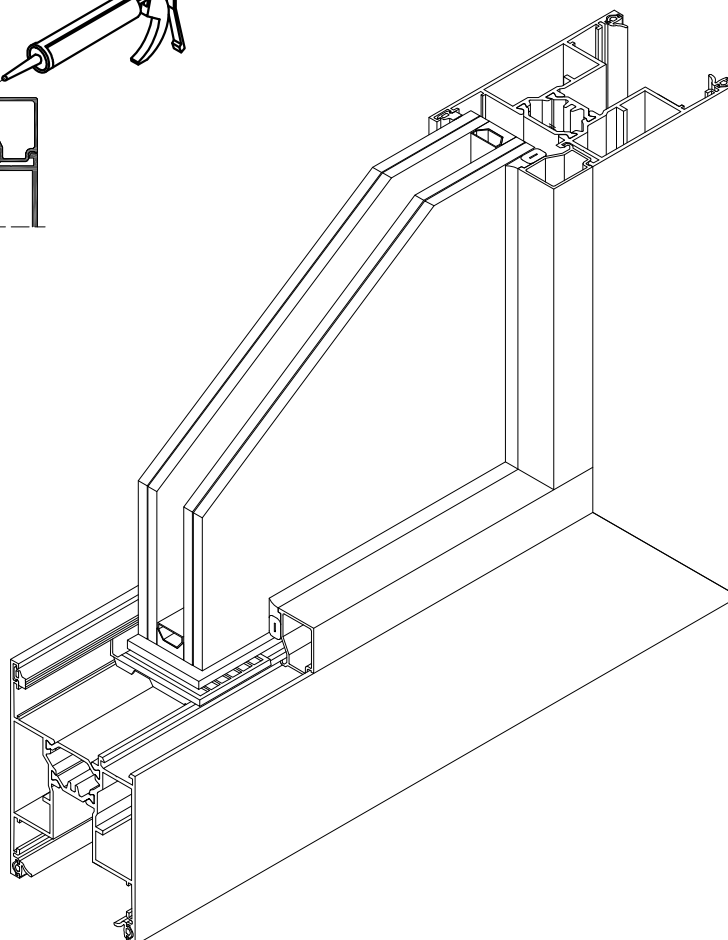
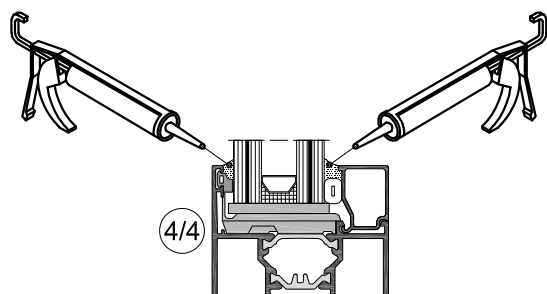
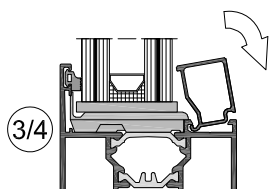
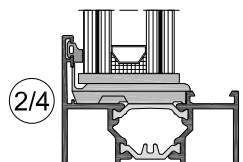
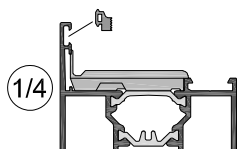



PANORAMICA - INTERNO

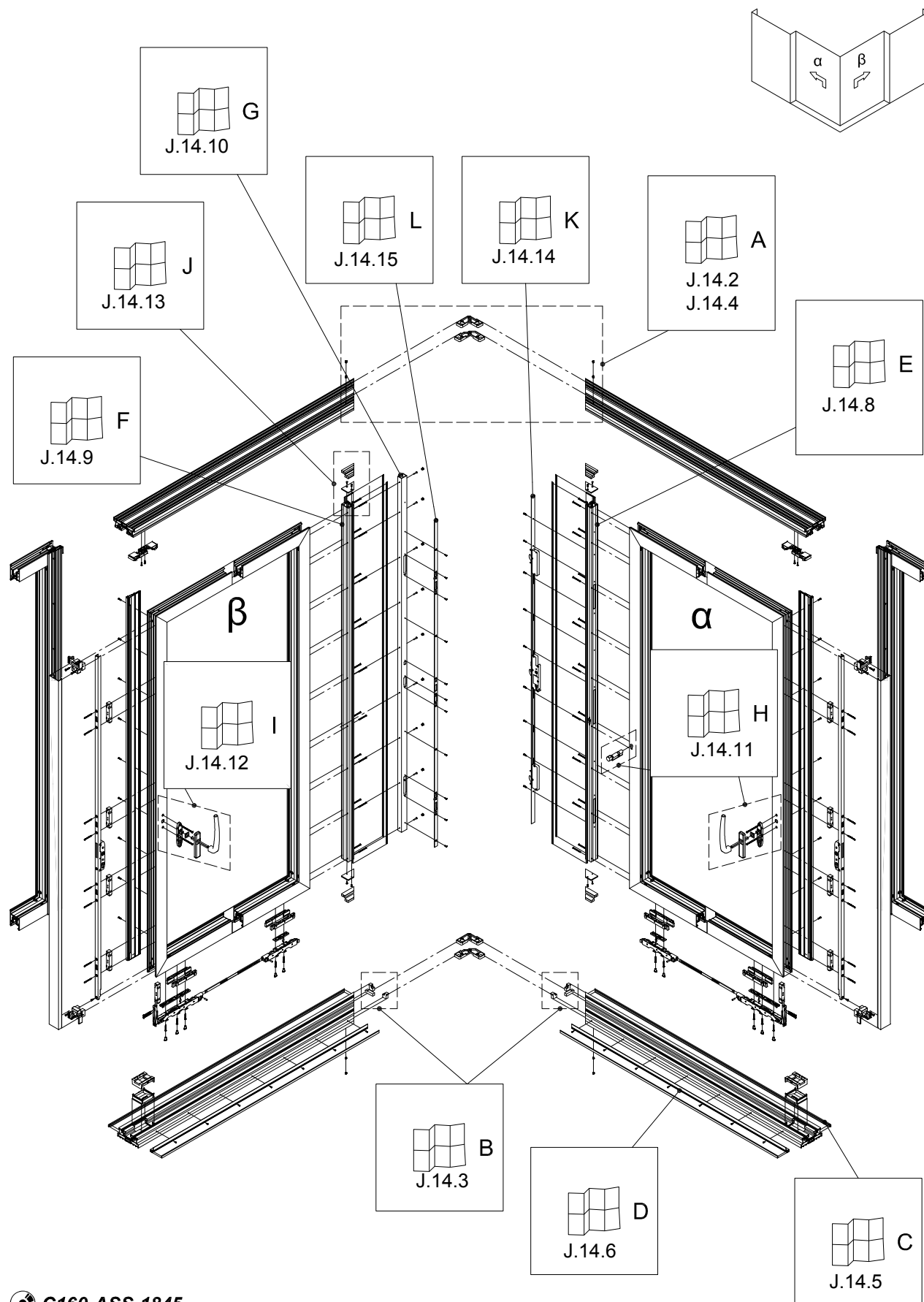

2-BINARI - OPERAZIONI TELAIO



SCZ810

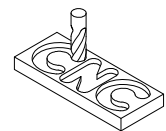
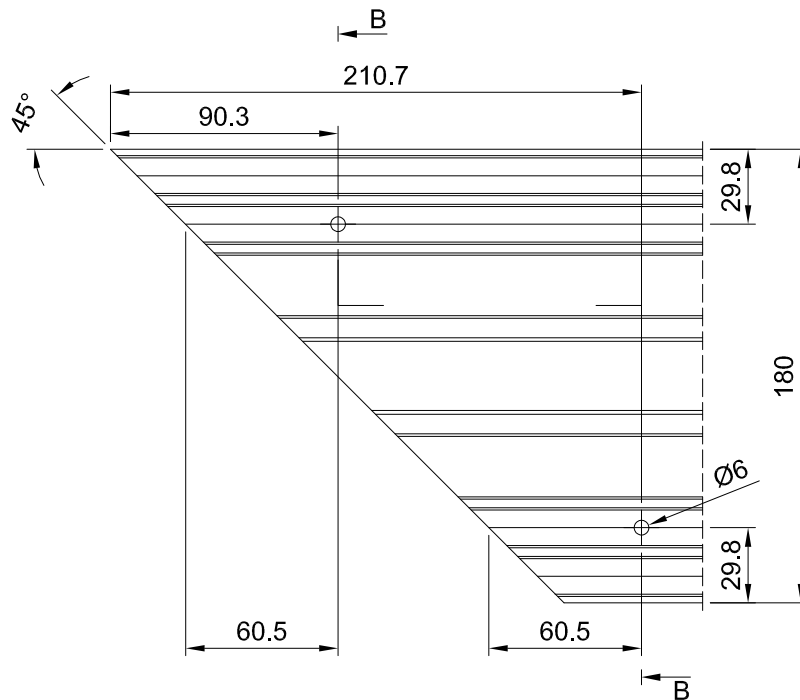
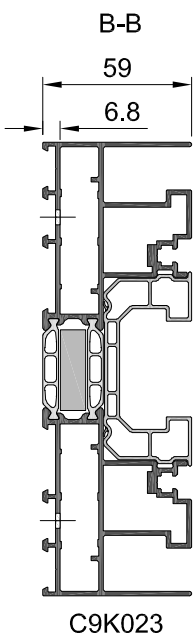
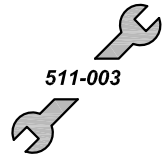
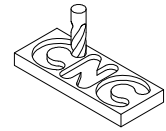
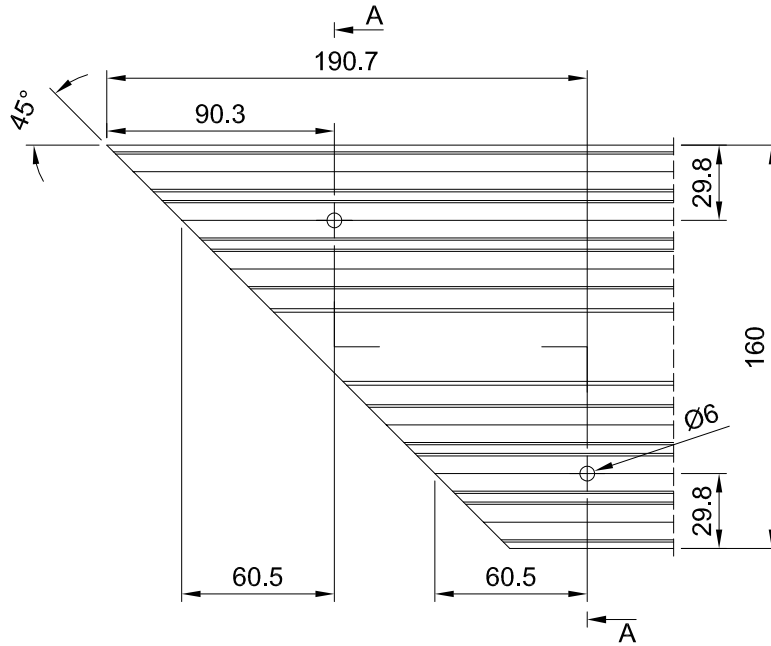
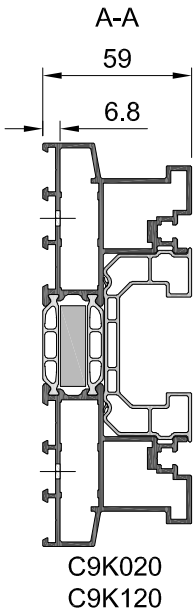
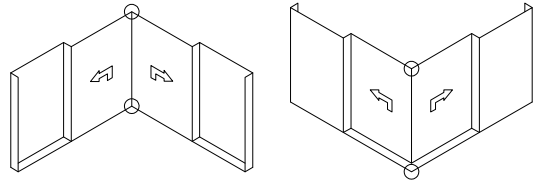

## ANGOLO GALLEGGIANTE

### 2-BINARI - ASSEMBLAGGIO TELAIO

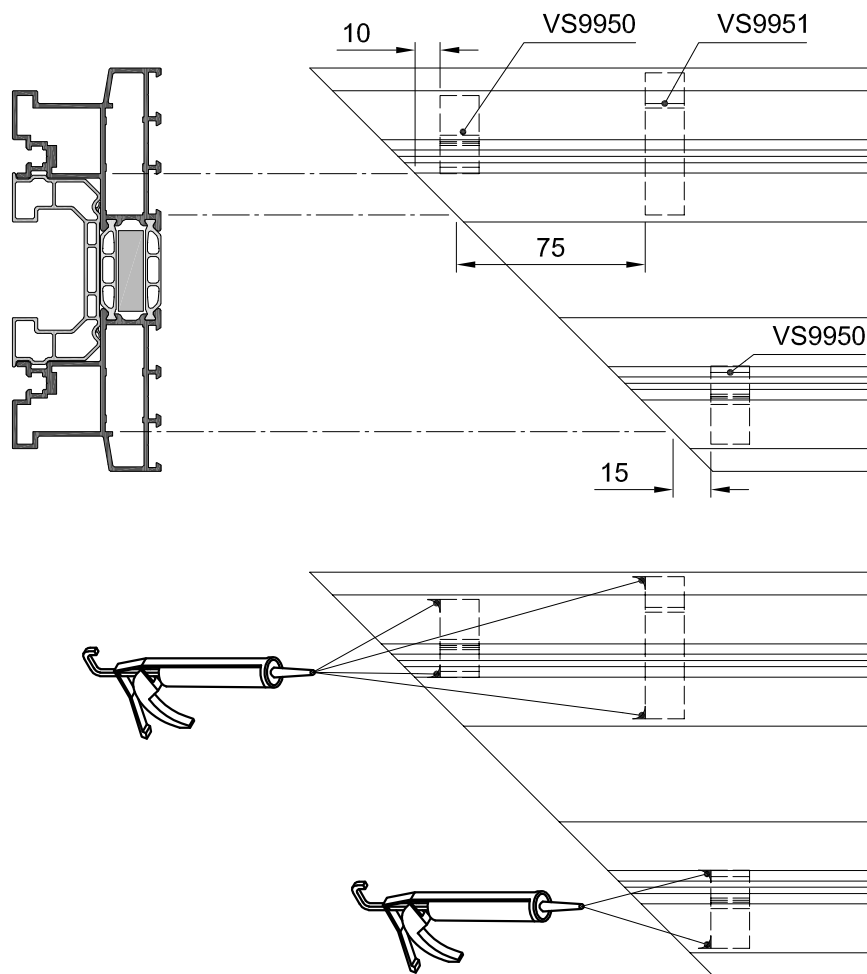
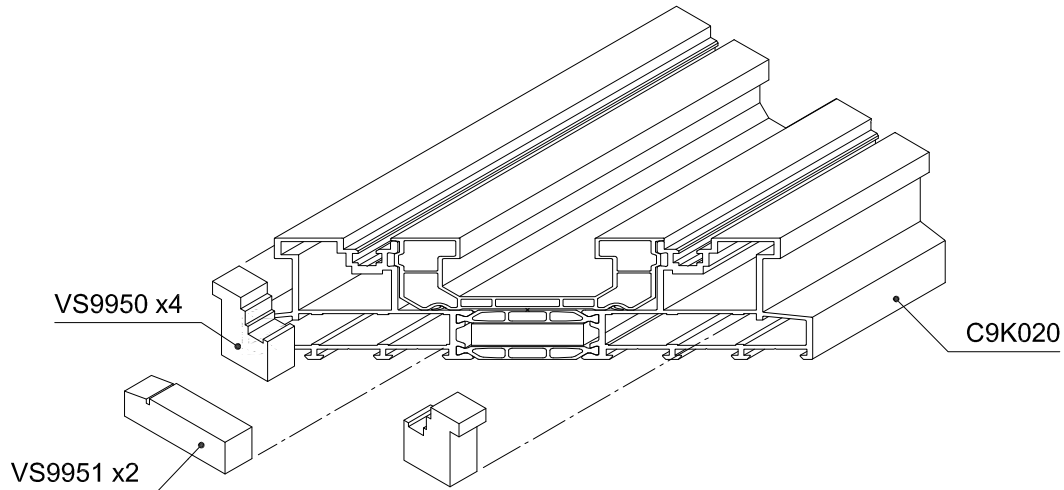
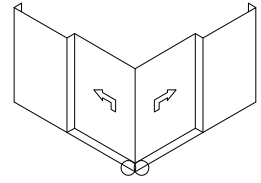

**2-BINARI - ASSEMBLAGGIO TELAIO**

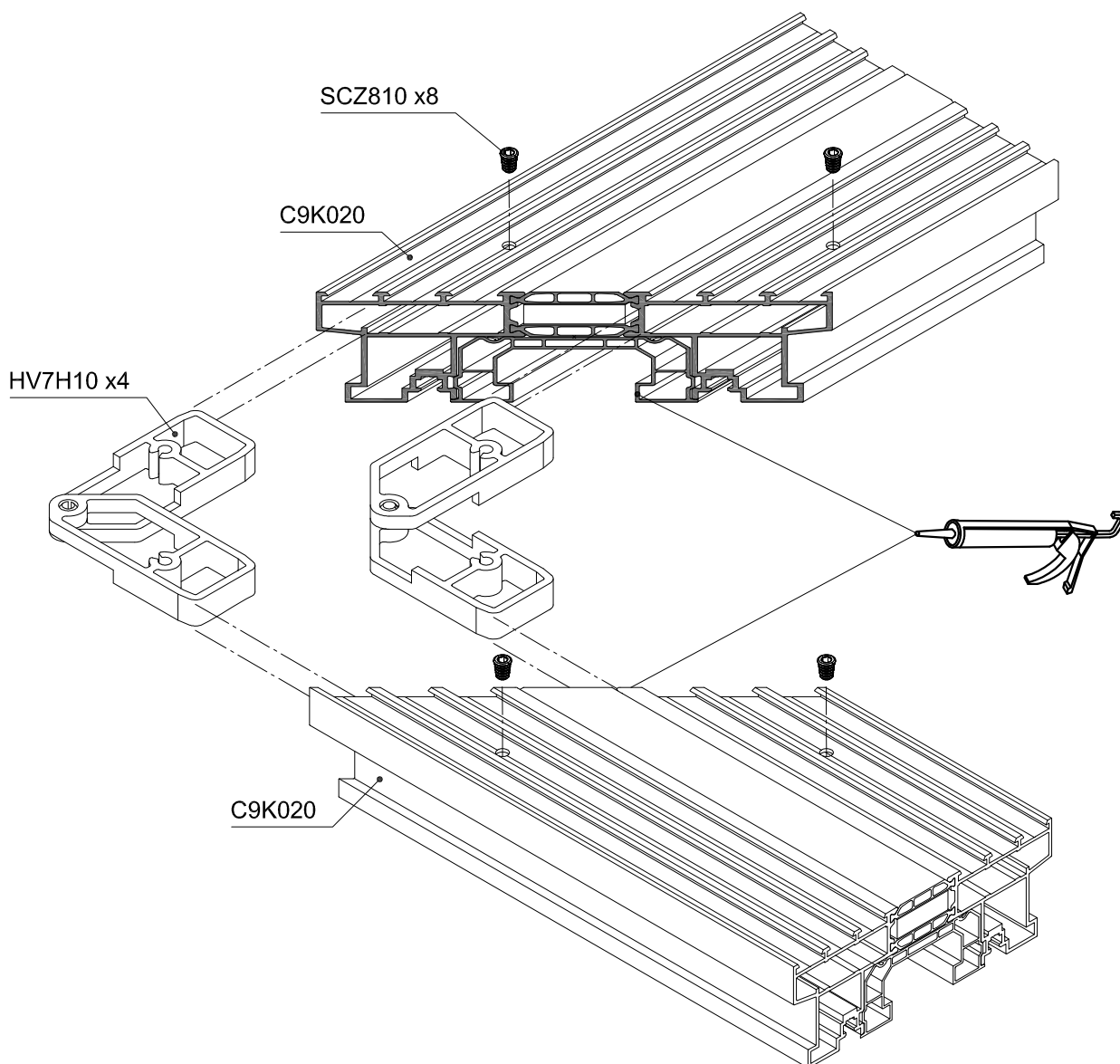
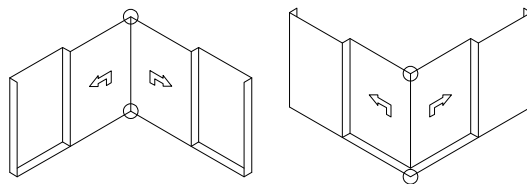

### 2-BINARI - ASSEMBLAGGIO TELAIO

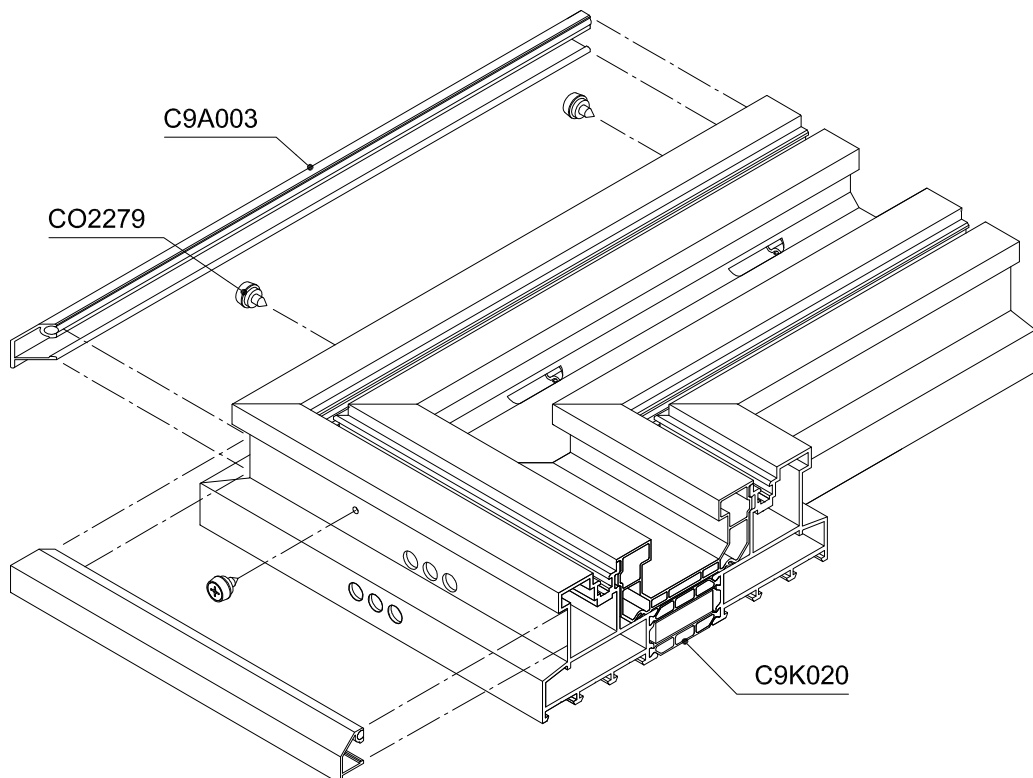
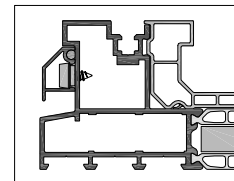
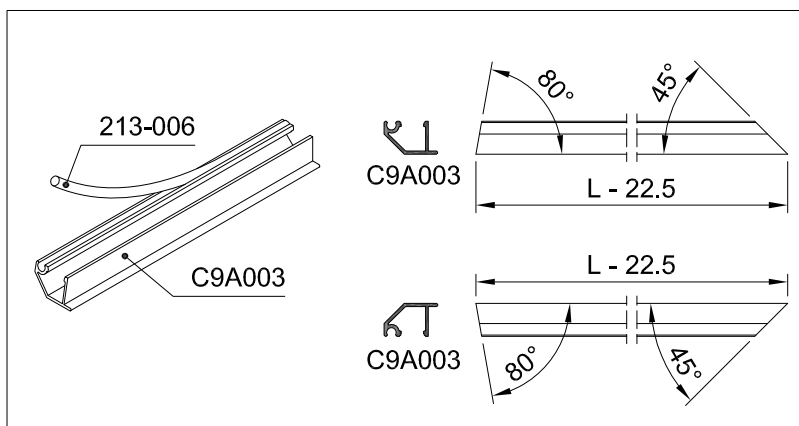
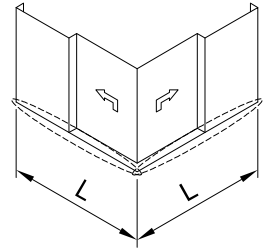

2-BINARI - ASSEMBLAGGIO TELAIO

1 / 2

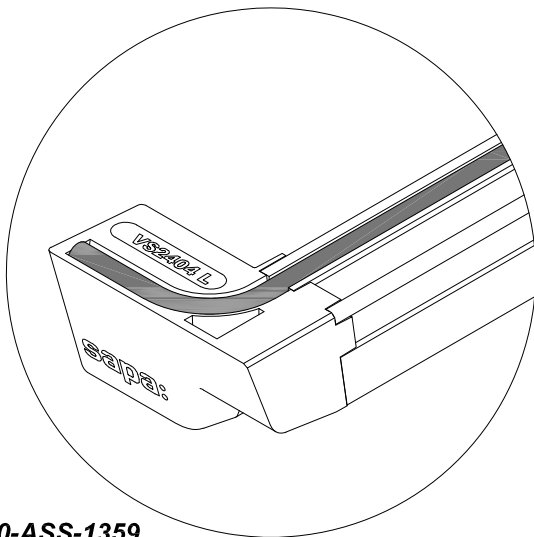
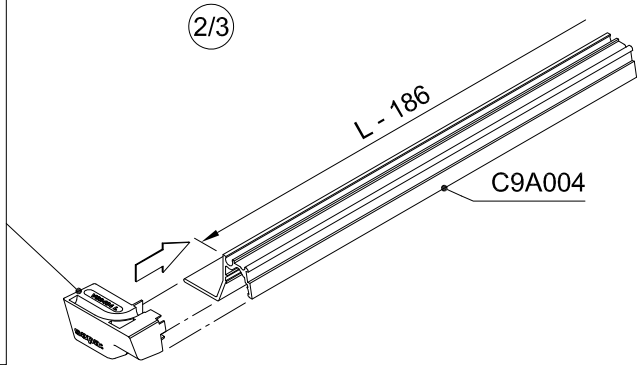
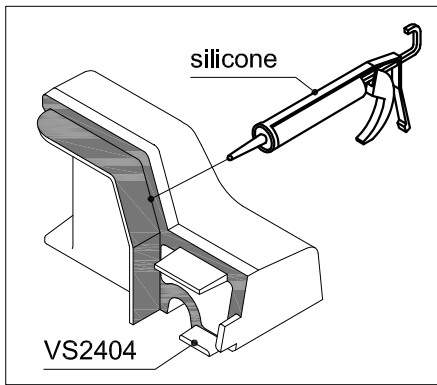
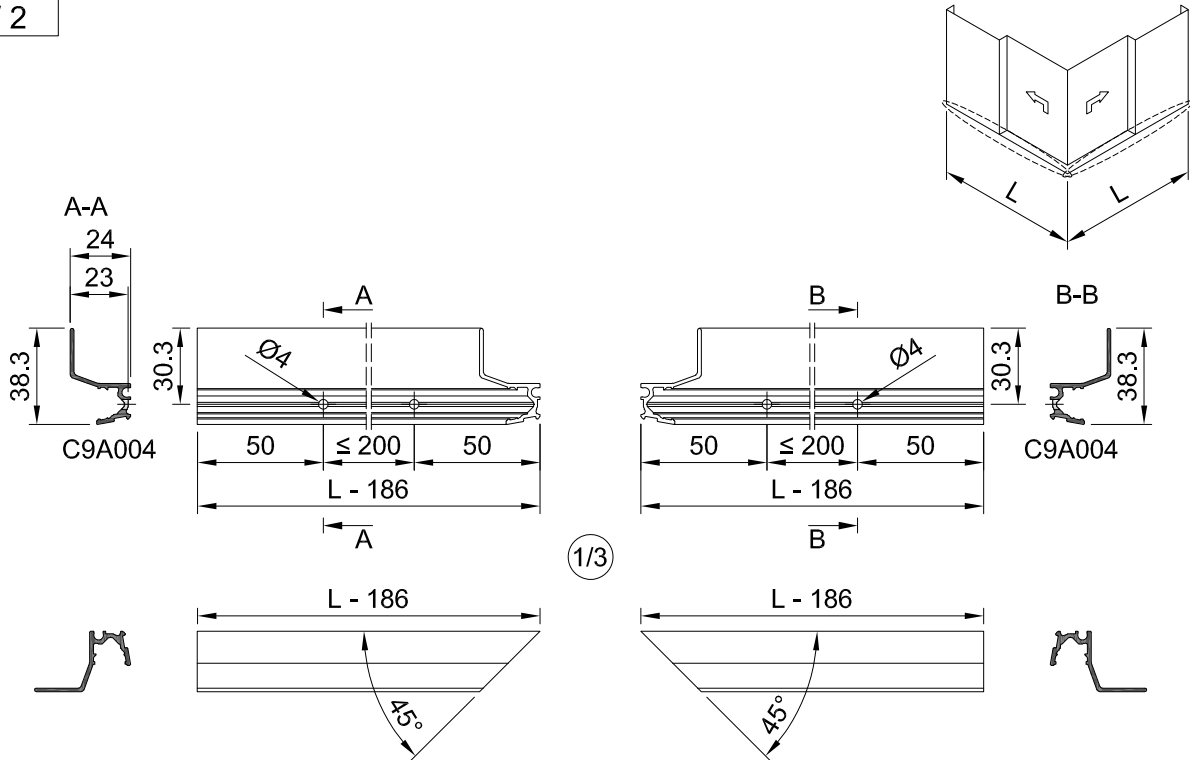

### 2-BINARI - ASSEMBLAGGIO TELAIO

2 / 2

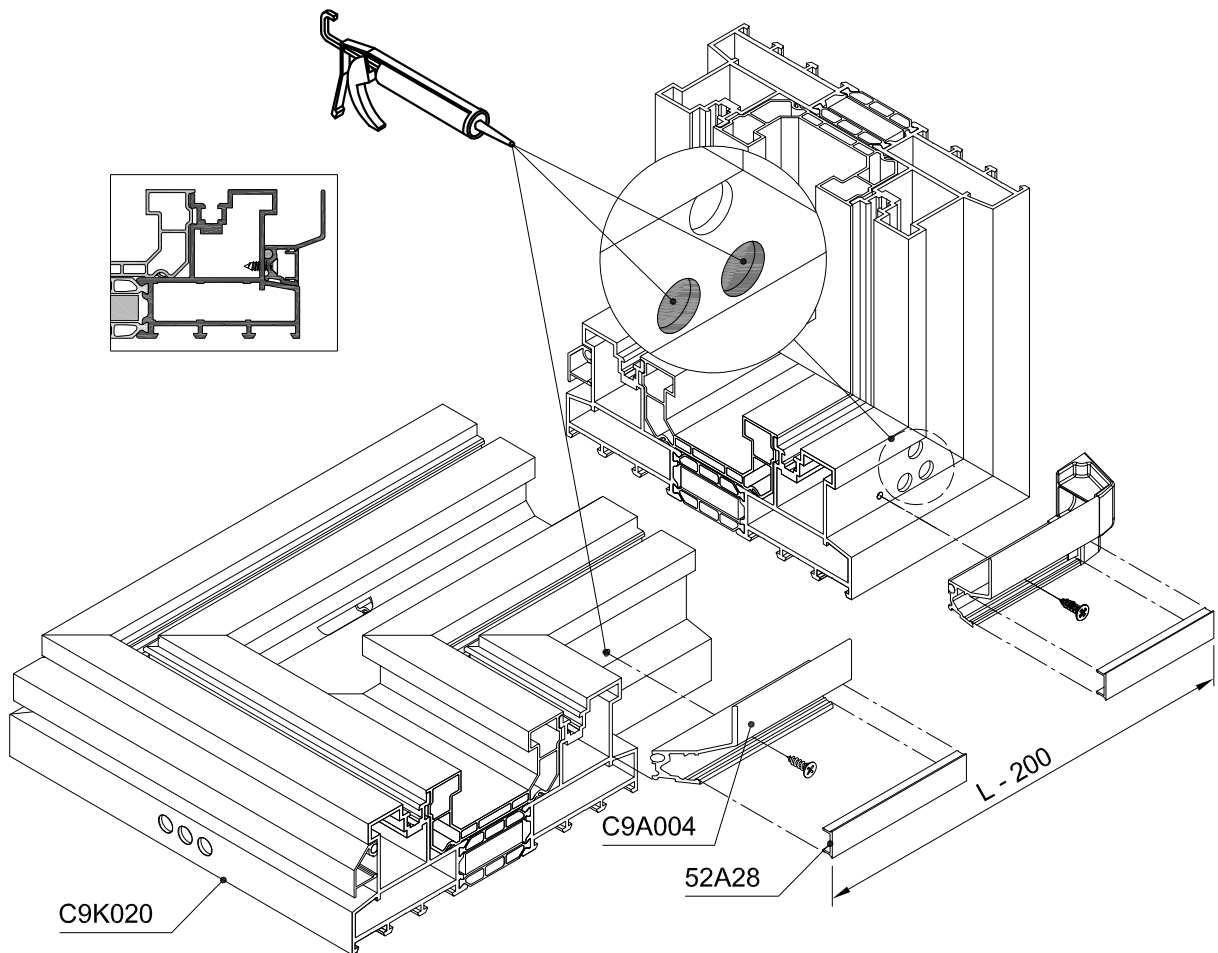
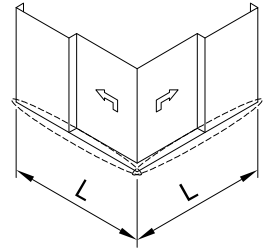

OPERAZIONI C9C003

1 / 5

	Hv	A
SF2127	2400 - 2550	0
SF2129	2550 - 2700	400

C9V001+KU2027
C9V051+KU2027
C9V004

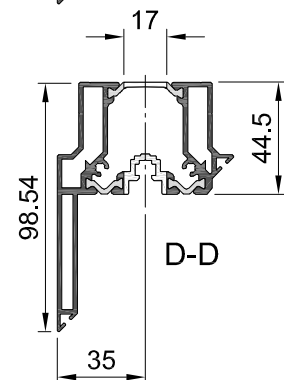
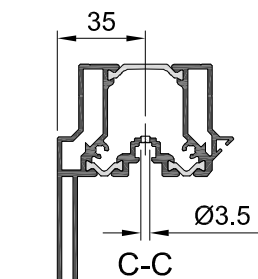
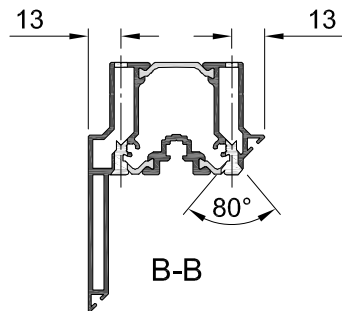
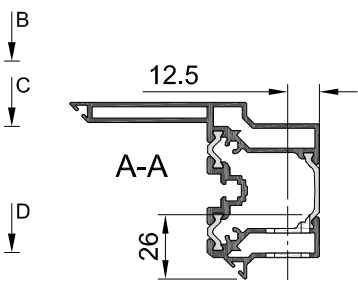
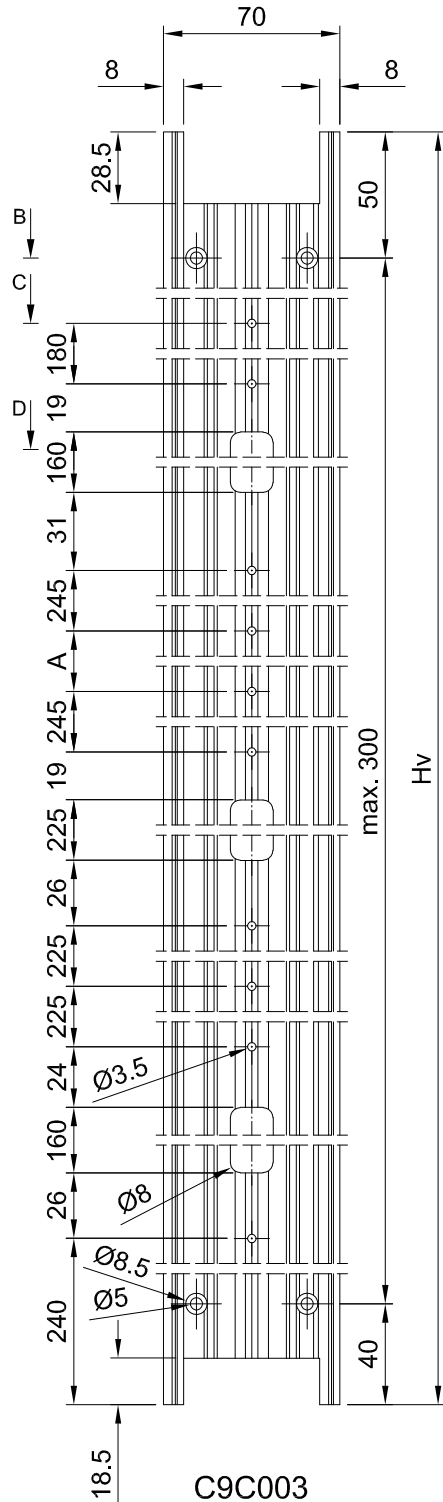
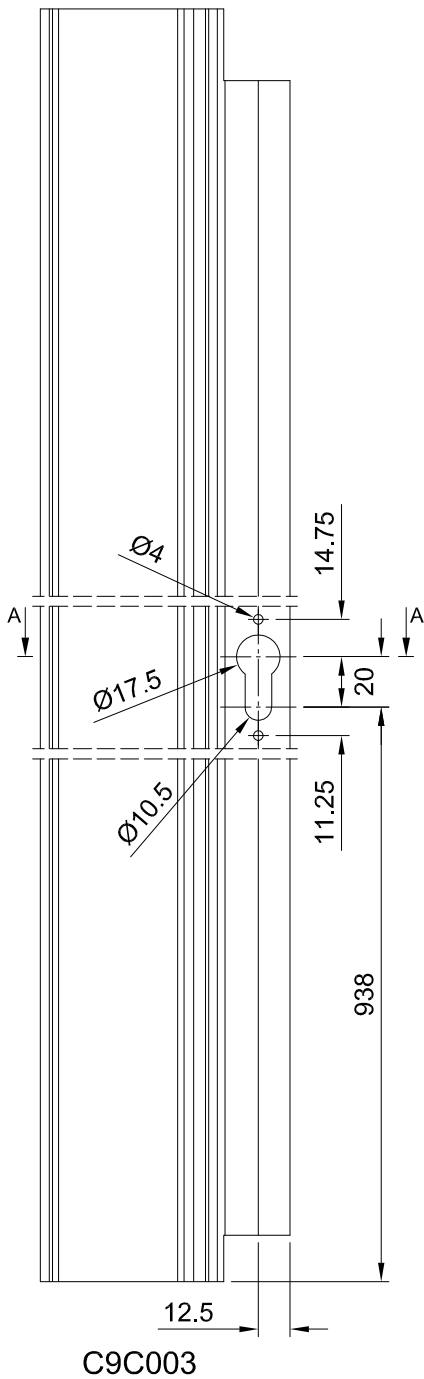
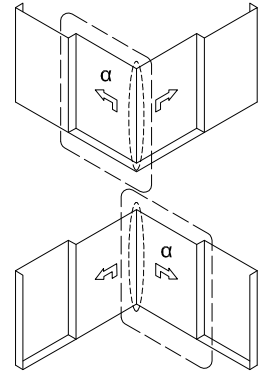



## ANGOLO GALLEGGIANTE

### OPERAZIONI C9C003

2 / 5

C9V001+KU2027
C9V051+KU2027
C9V004

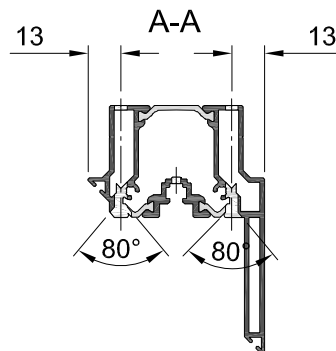
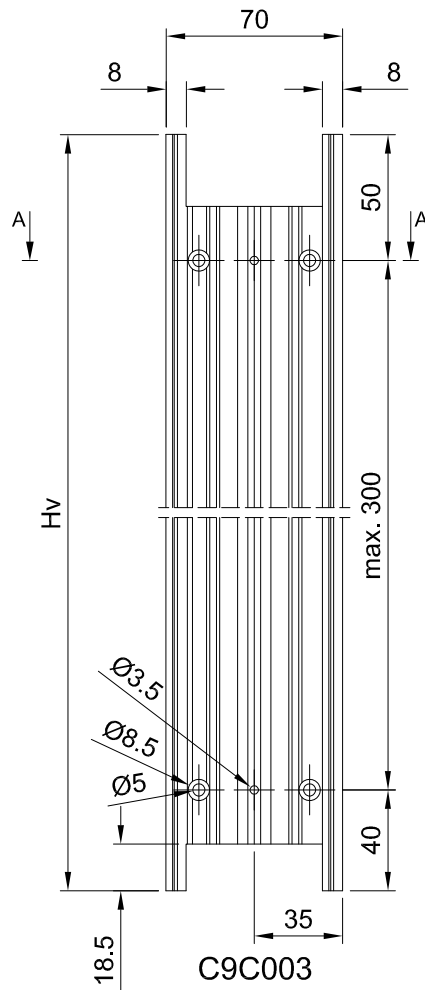
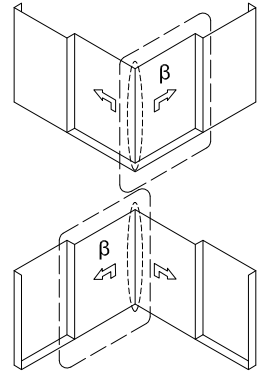

OPERAZIONI RB0086

3 / 5

C9V001+KU2027
C9V051+KU2027
C9V004

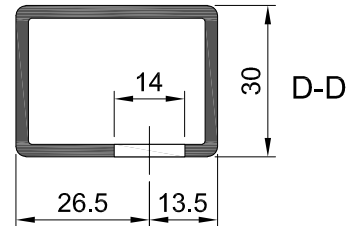
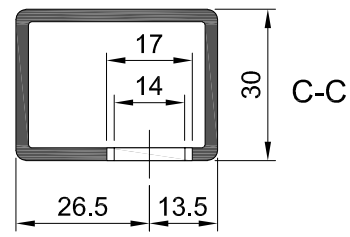
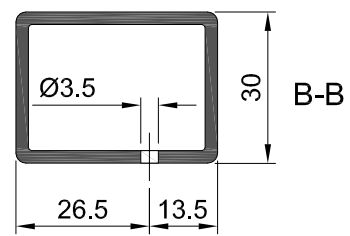
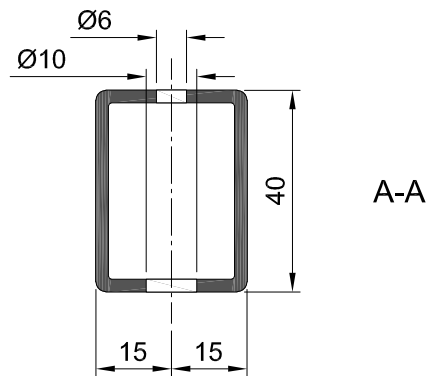
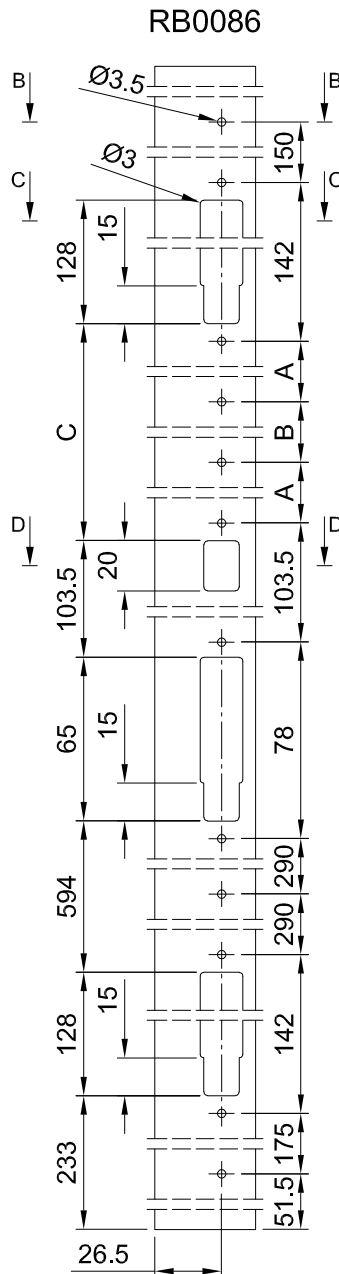
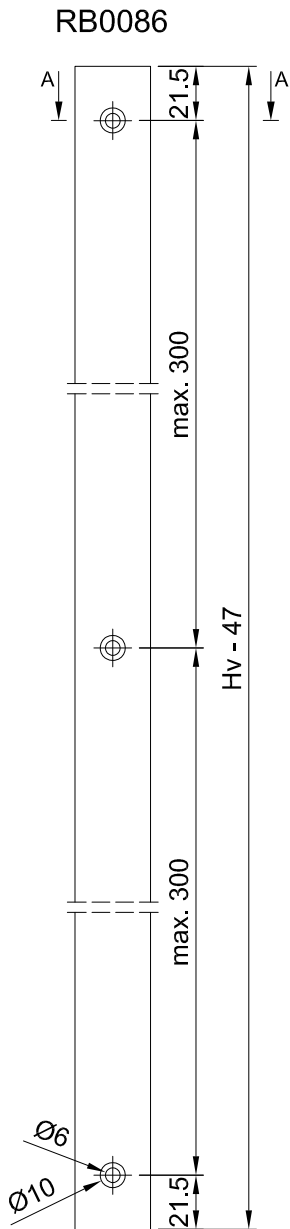
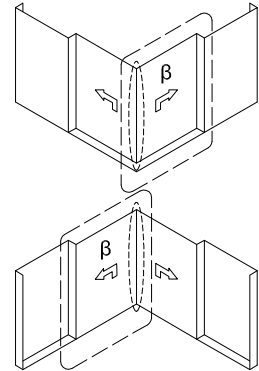

	Hv	A	B	C
SF3066	2400 - 2550	282.5	/	578
SF3068	2550 - 2700	282.5	400	978

### OPERAZIONI C9V001

4 / 5

C9V001+KU2027
C9V051+KU2027
C9V004

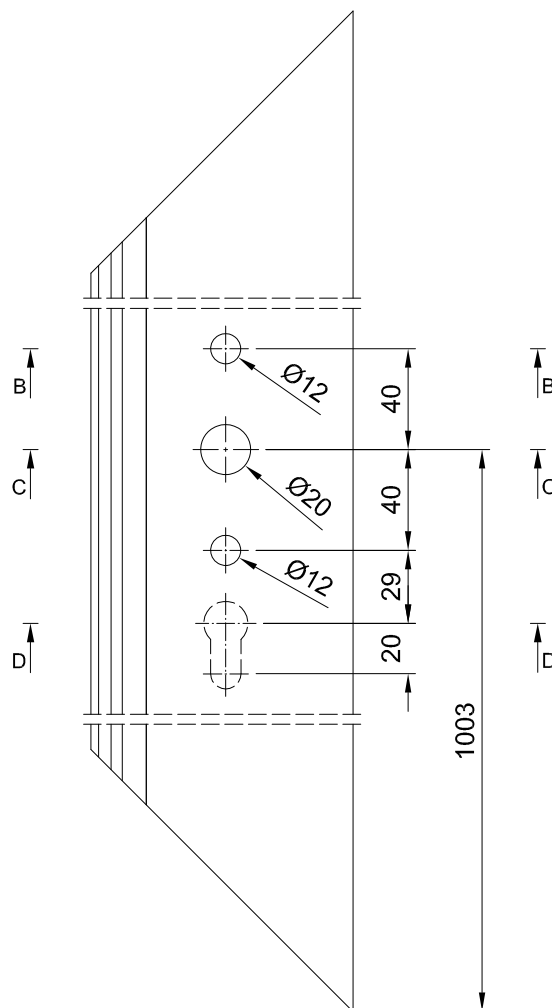
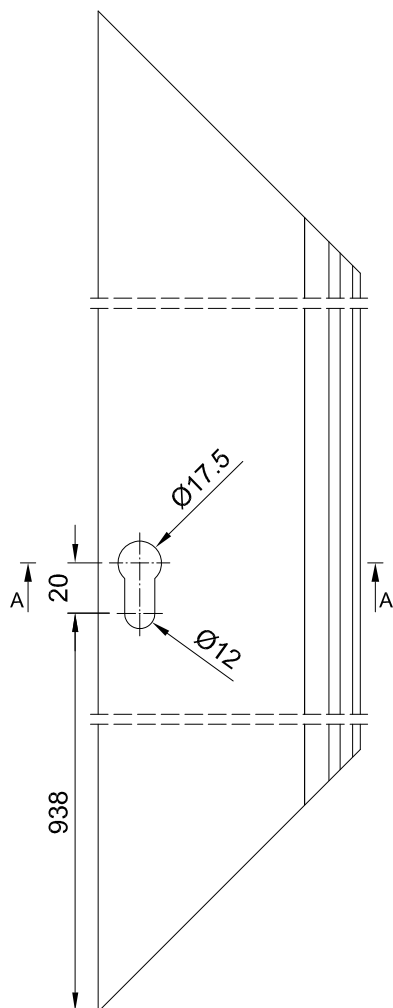
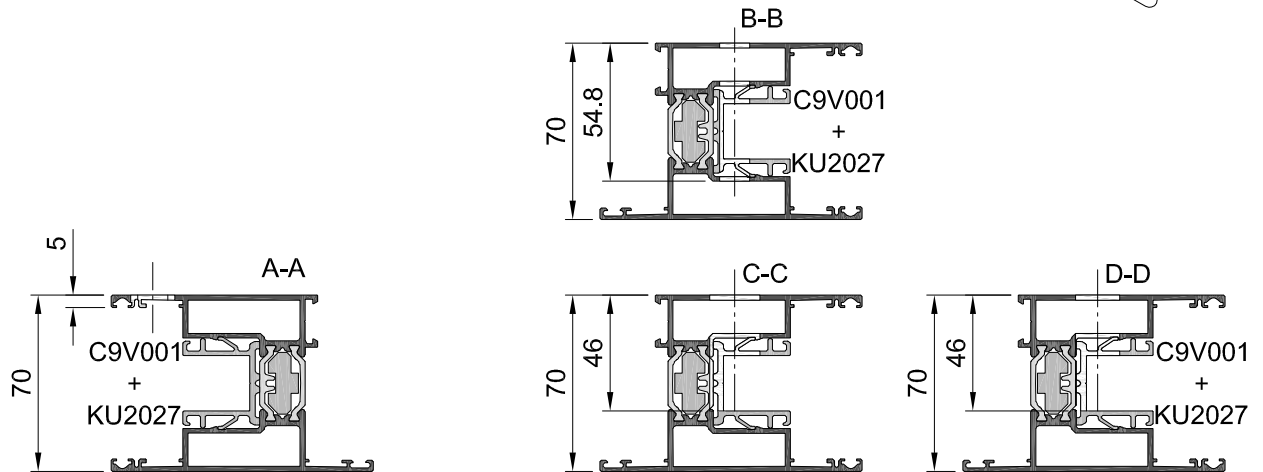
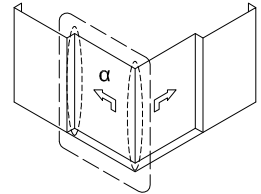

C160-ASS-2294

**OPERAZIONI C9V001**

5 / 5

C9V001+KU2027
C9V051+KU2027
C9V004

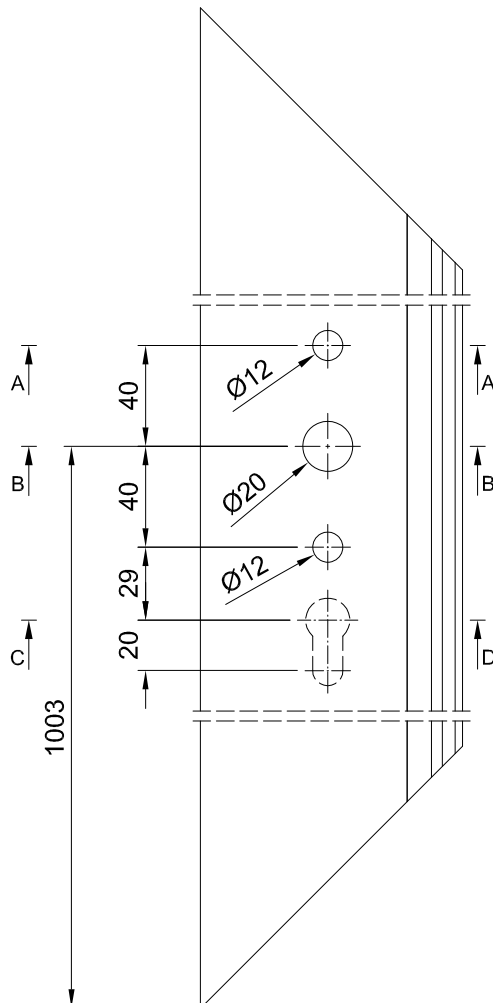
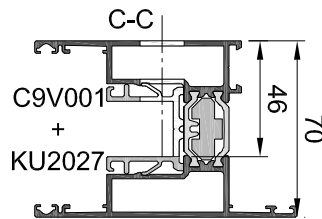
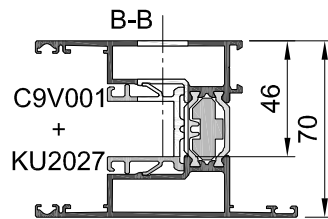
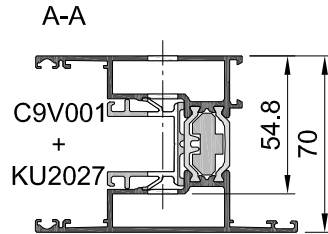
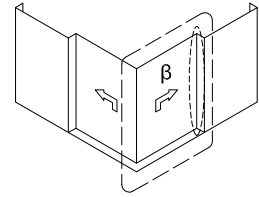

## ANGOLO GALLEGGIANTE

### ASSEMBLAGGIO C9C003 + CO1102 + RU4033

1 / 3

C9V001+KU2027
C9V051+KU2027
C9V004

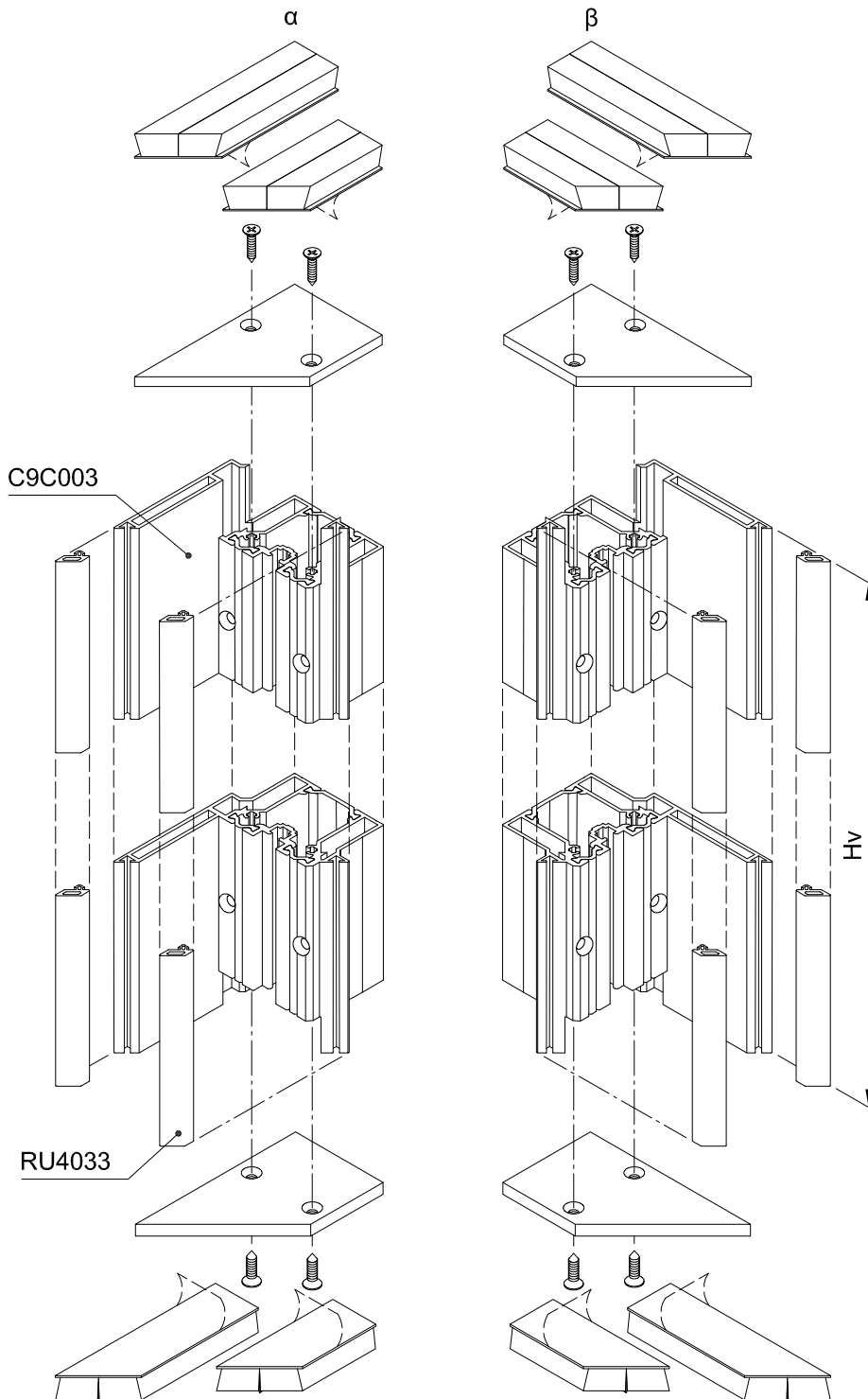
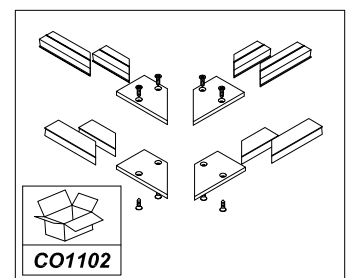
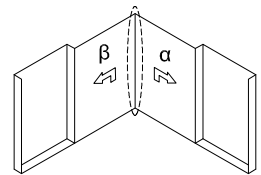
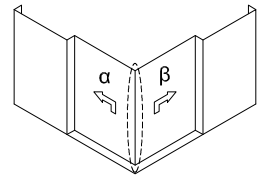

**ASSEMBLAGGIO C9C003 + SF212X**

2 / 3

C9V001+KU2027
C9V051+KU2027
C9V004

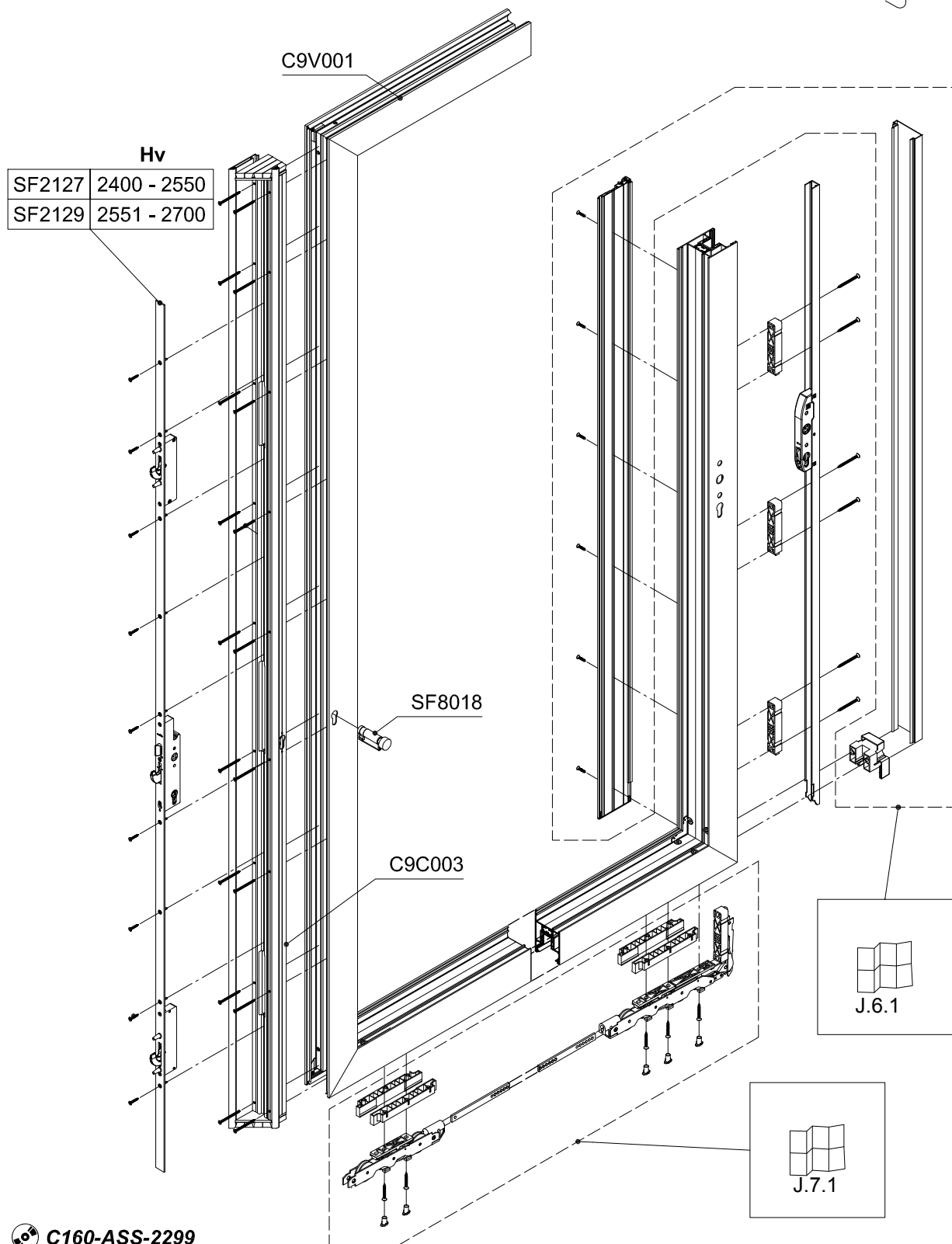
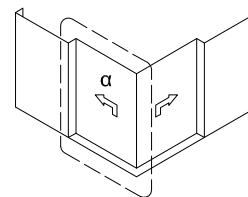

 C160-ASS-2299

### ASSEMBLAGGIO C9C003 + RB0086 + SF36X

3 / 3

C9V001+KU2027
C9V051+KU2027
C9V004

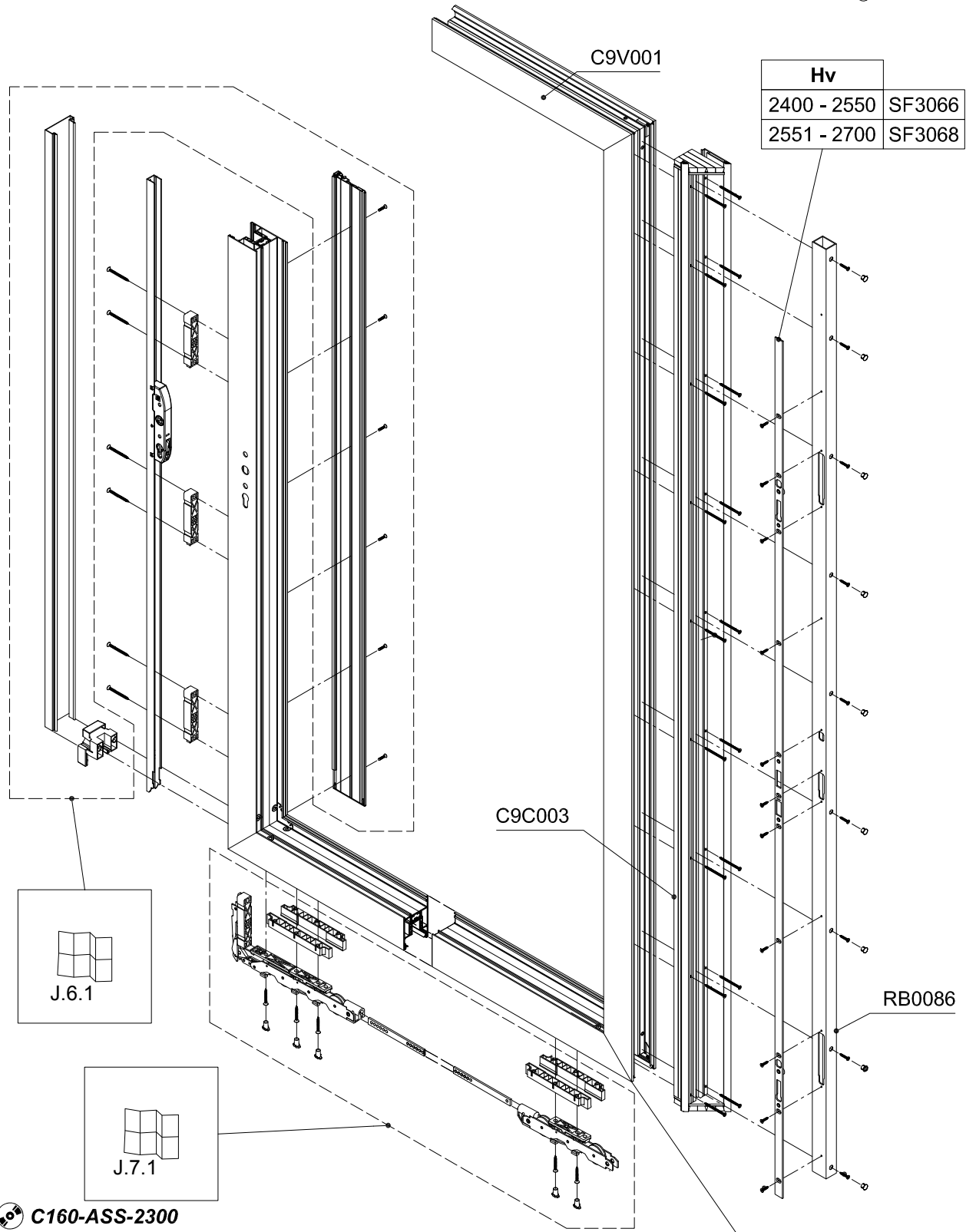
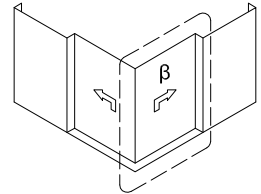

Hv	
2400 - 2550	SF3066
2551 - 2700	SF3068

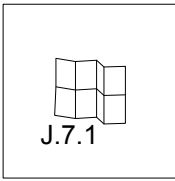
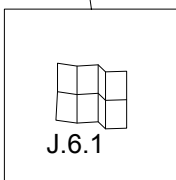

C160-ASS-2300

OPERAZIONI - INTERNO

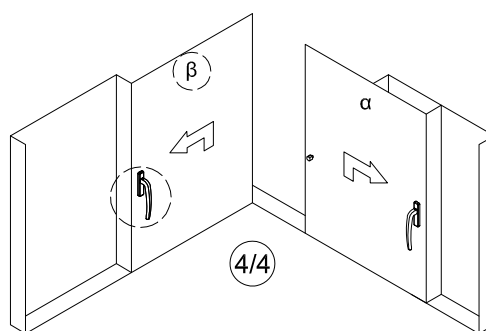
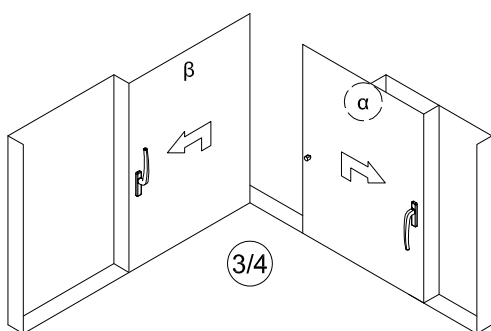
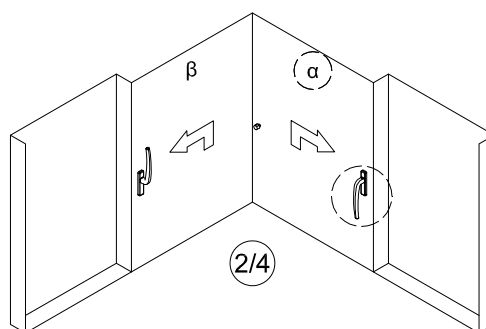
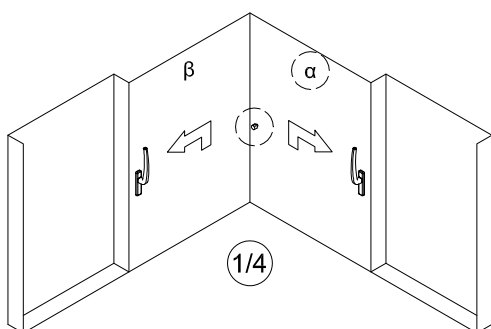



1 / 4

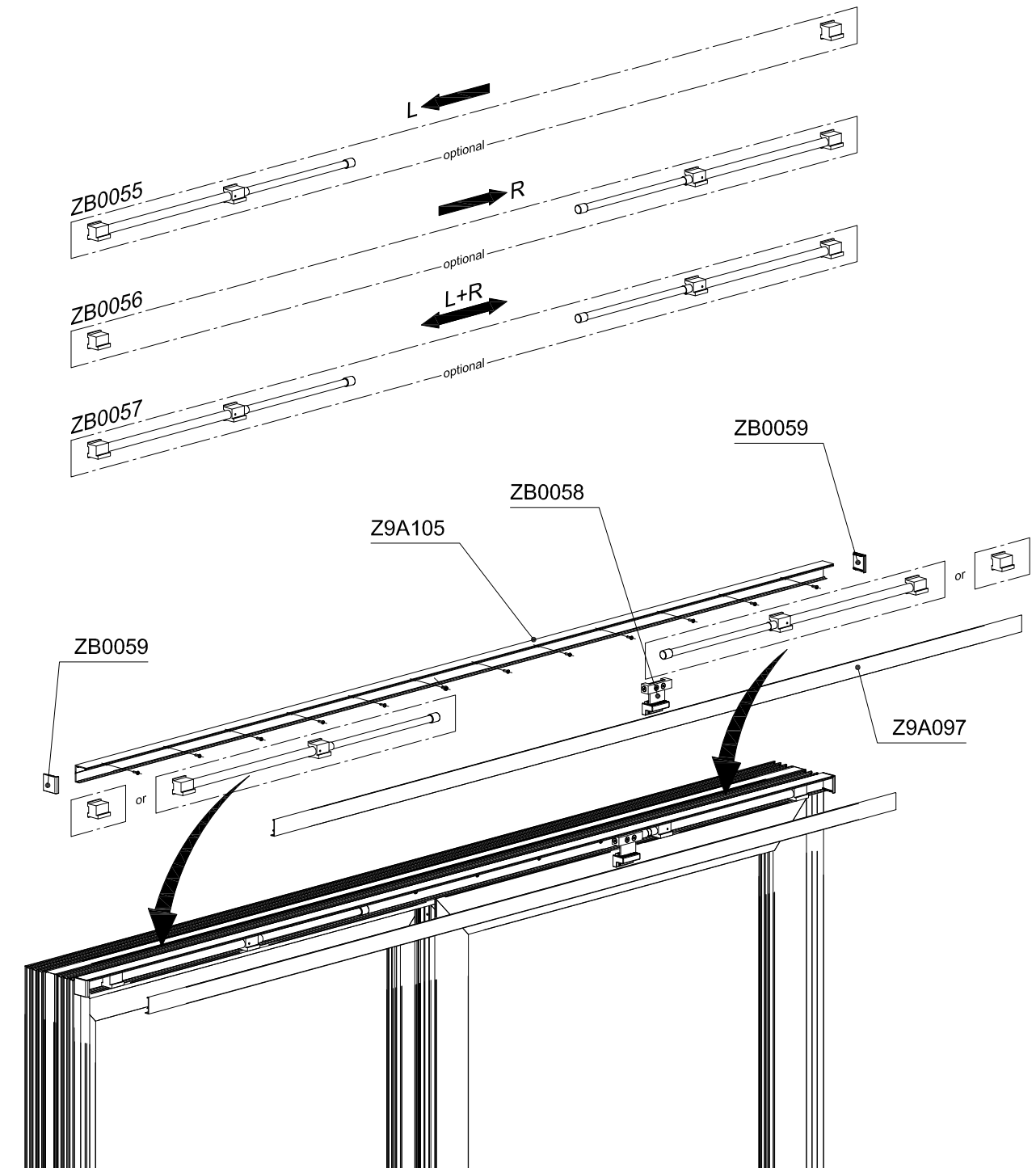
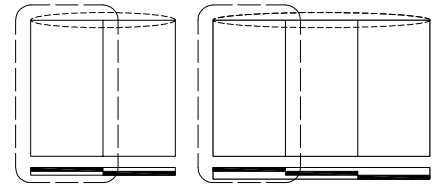

2 / 4

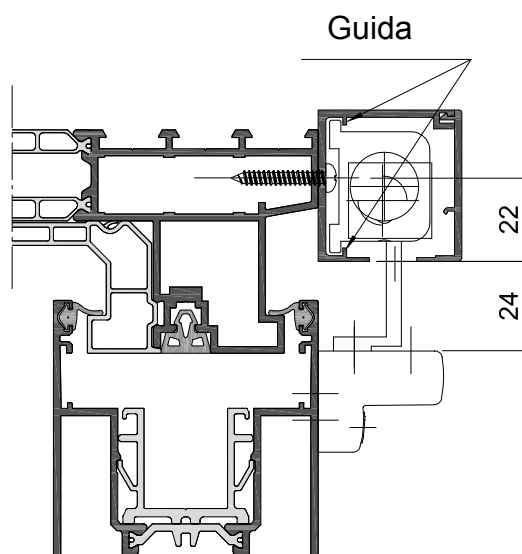
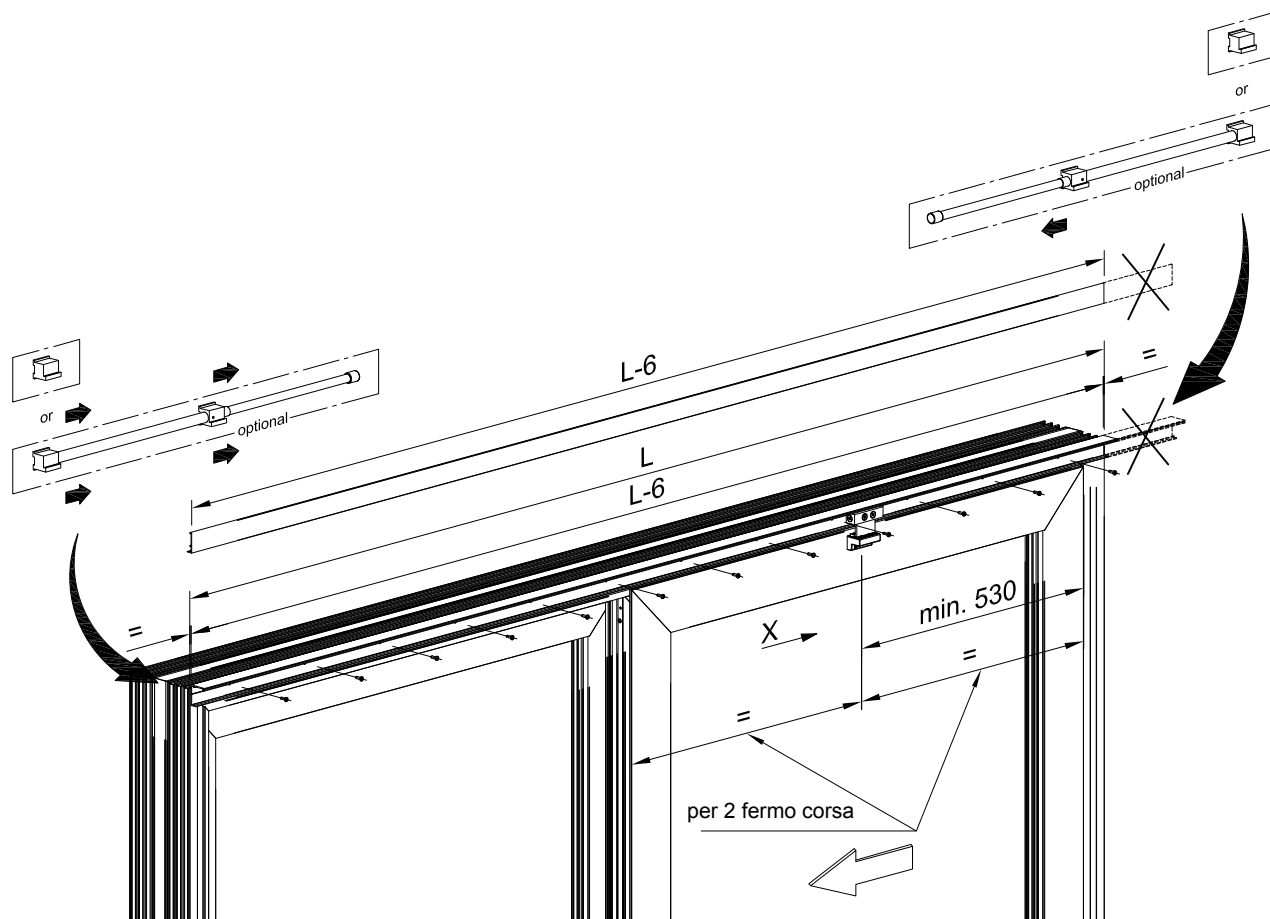
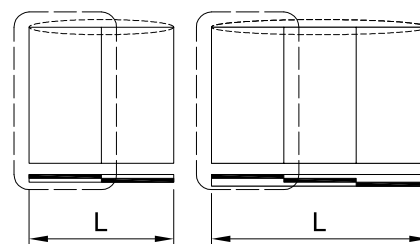

 C160-ASS-1605L

3/4

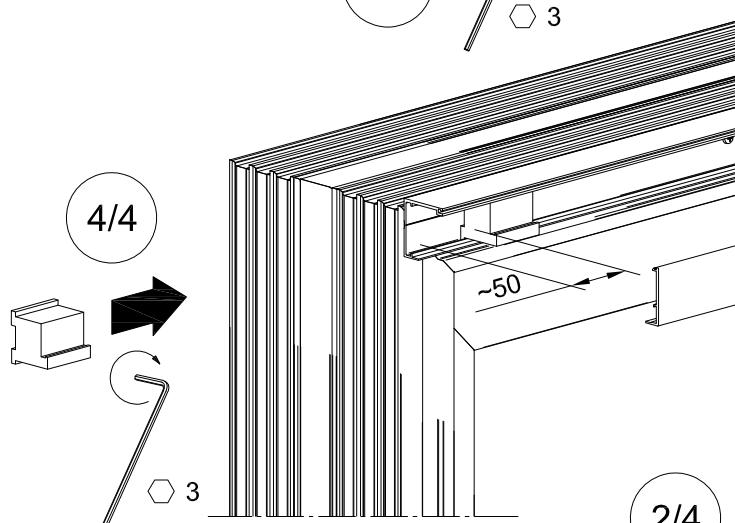
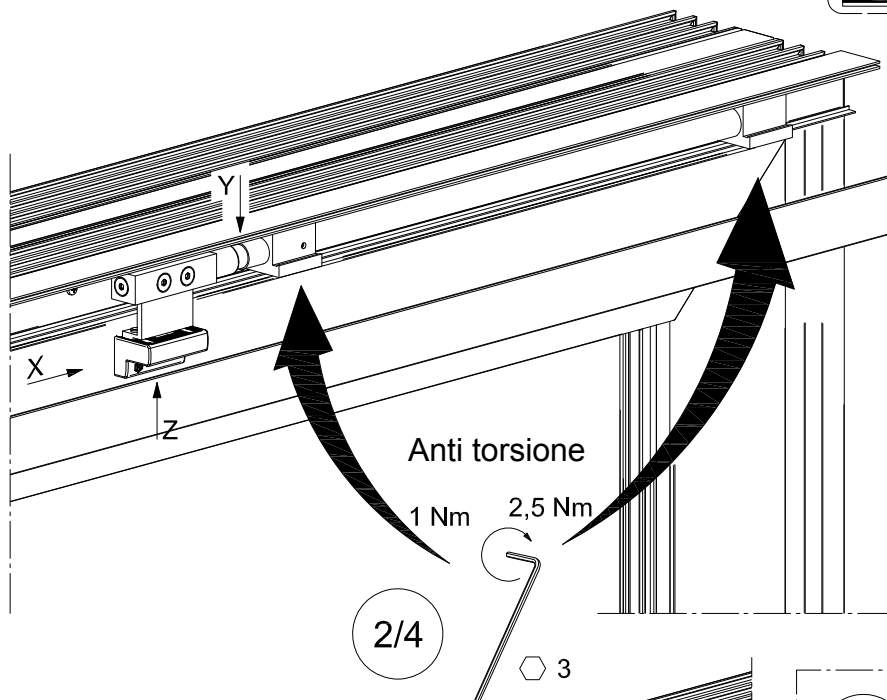
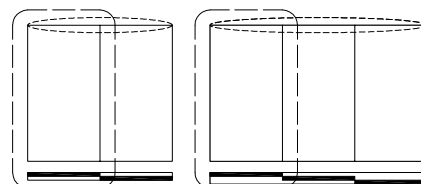

Vista Y



Vista X2

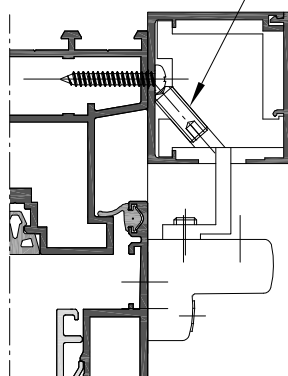

1/4

3/4 Regolazioni

Vista X1

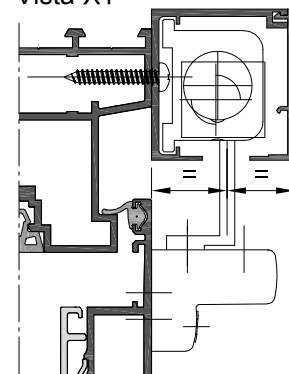

Vista Z

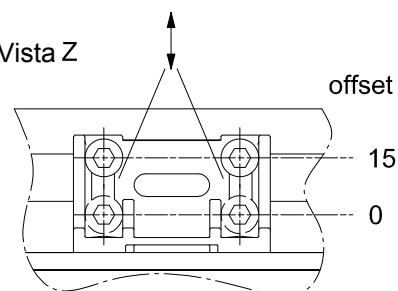

4 / 4

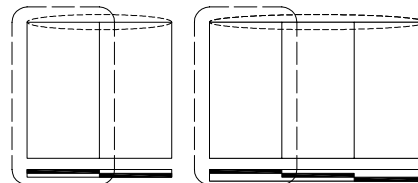

Riduzione della forza di chiusura da applicare con regolazione del fine corsa

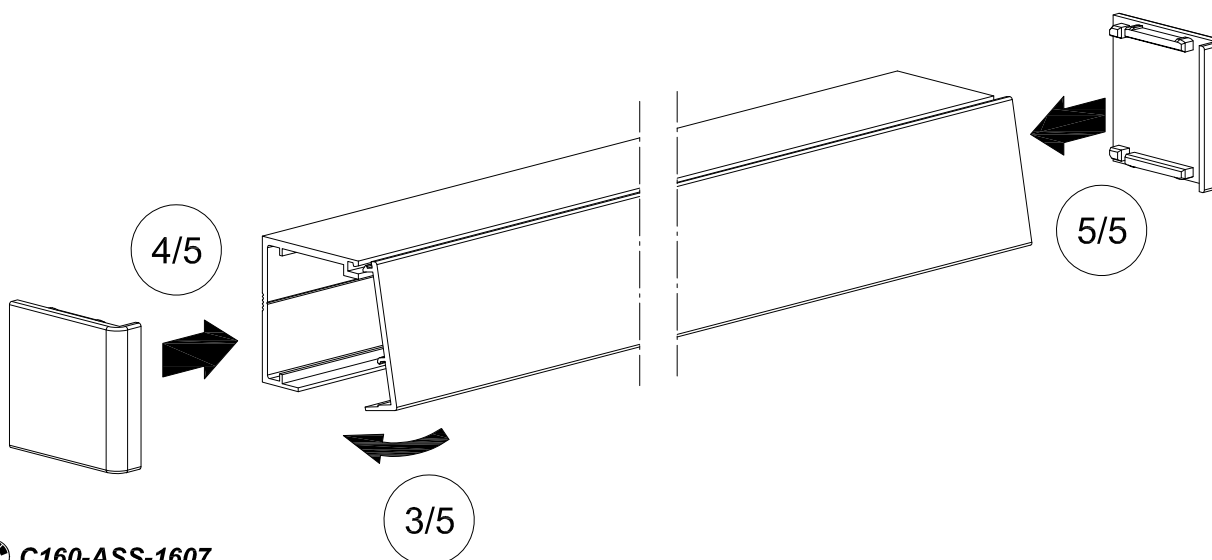
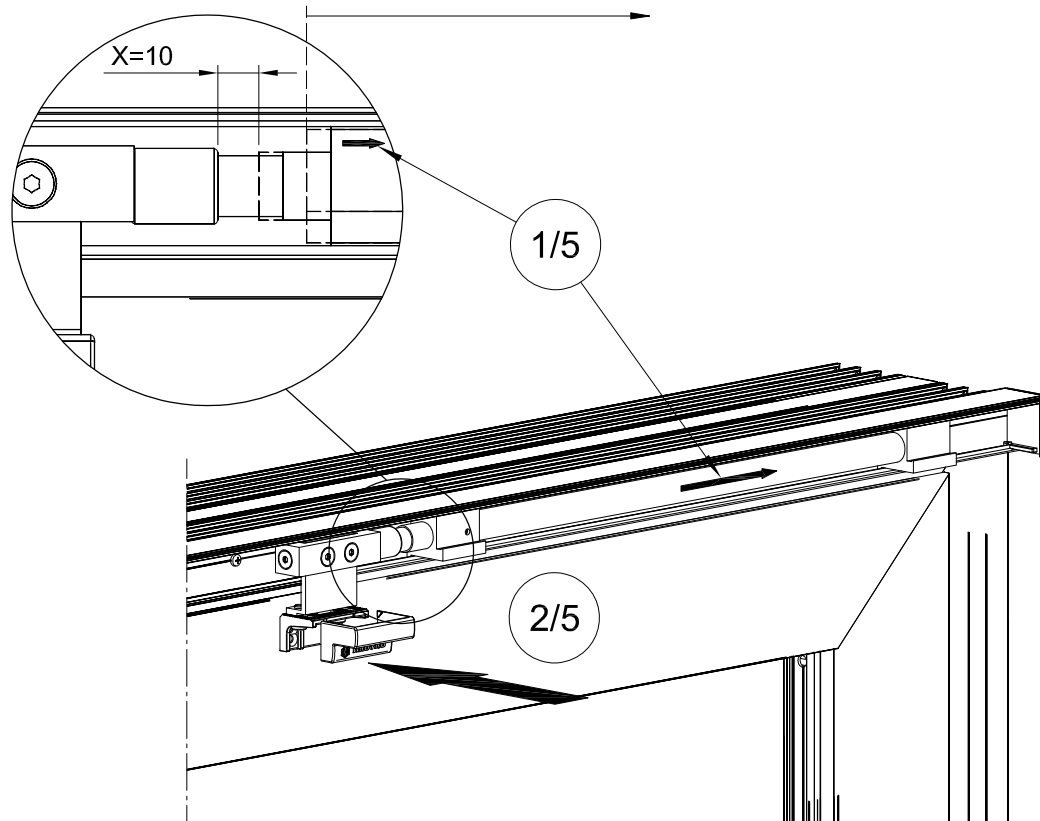

 C160-ASS-1607

### FERRAMENTA ALZANTE-SCORREVOLE

1 / 4

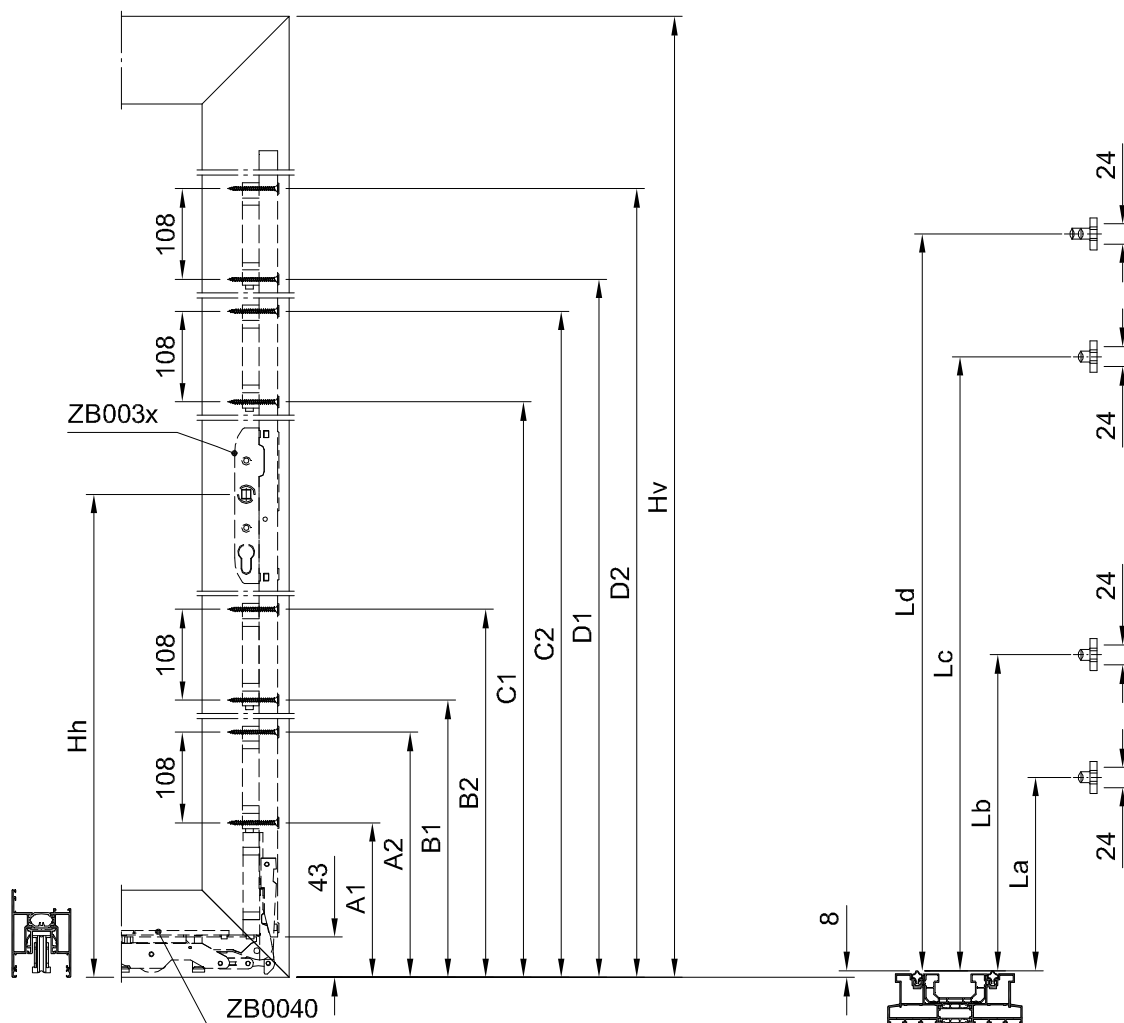

Hv			Hh	A		B		C		D		E	F		L				
min	max			A1	A2	B1	B2	C1	C2	D1	D2		F1	F2	La	Lb	Lc	Ld	Lf
1180	1877	ZB0033	403		-	-	-	554	662	954	1062					-	600	1000	
1878	2177	ZB0034	1003	204	312	704	812	1154	1262	1554	1662	-	-	-	250	750	1200	1600	
2178	2477	ZB0035								1854	1962							1900	
2478	2777	ZB0036								2154	2262							2200	
2778	3077	ZB0035 + ZB0046	Vedi Pagina 2 / 4																
3078	3377	ZB0035 + ZB0046																	

**FERRAMENTA ALZANTE-SCORREVOLE**

2 / 4

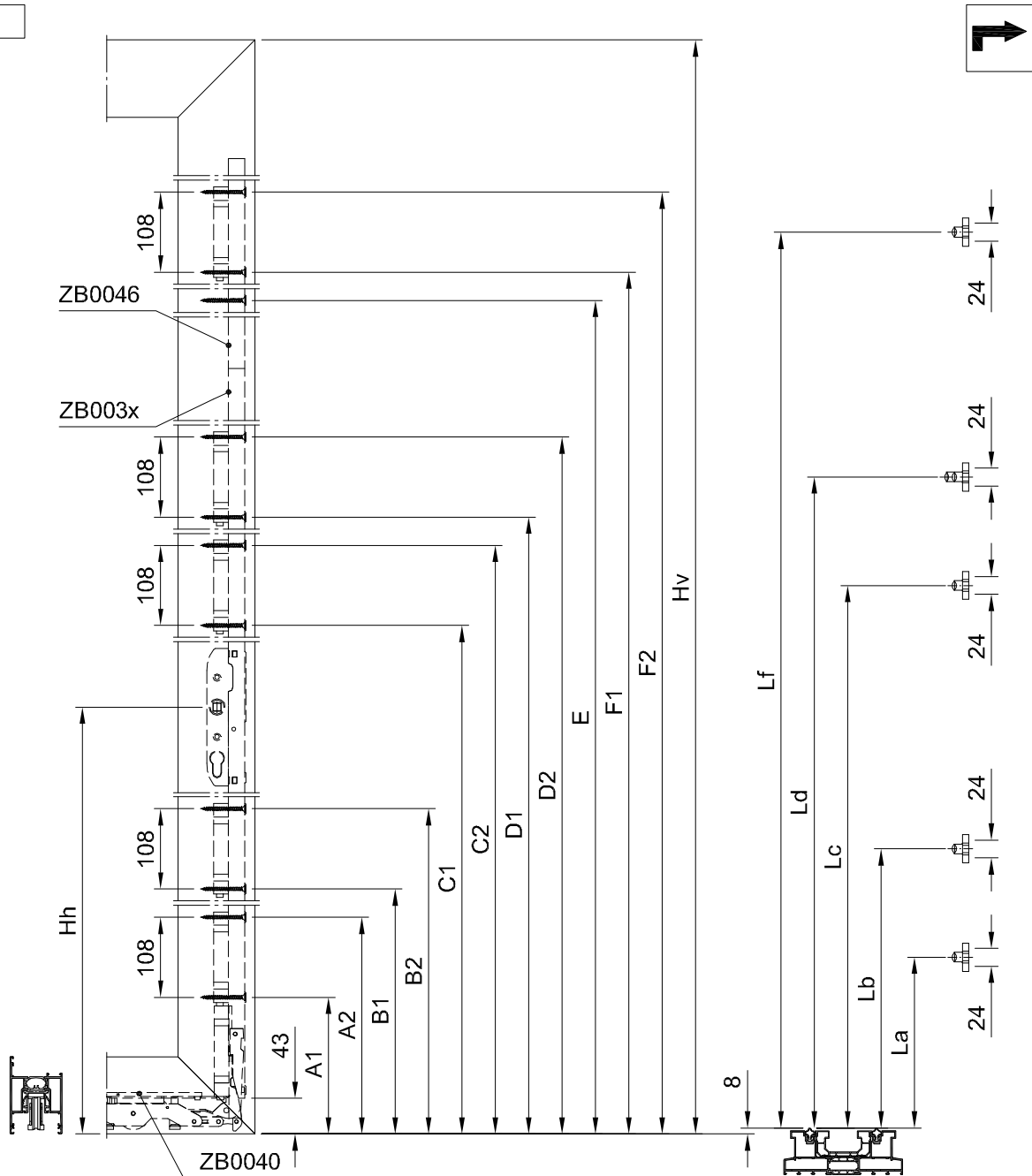

Hv		Hh	A		B		C		D		E	F		L					
min	max		A1	A2	B1	B2	C1	C2	D1	D2		F1	F2	La	Lb	Lc	Ld	Lf	
1180	1877	ZB0033	Vedi Pagina 1 / 4																
1878	2177	ZB0034																	
2178	2477	ZB0035																	
2478	2777	ZB0036																	
2778	3077	ZB0035 + ZB0046	1003	204	312	704	812	1154	1262	1854	1962	HV - 549	HV - 325	HV - 217	250	750	1200	1900	HV - 271
3078	3377	ZB0035 + ZB0046								2154	2262								

 **C160-ASS-3101**

### FERRAMENTA ALZANTE-SCORREVOLE

3 / 4

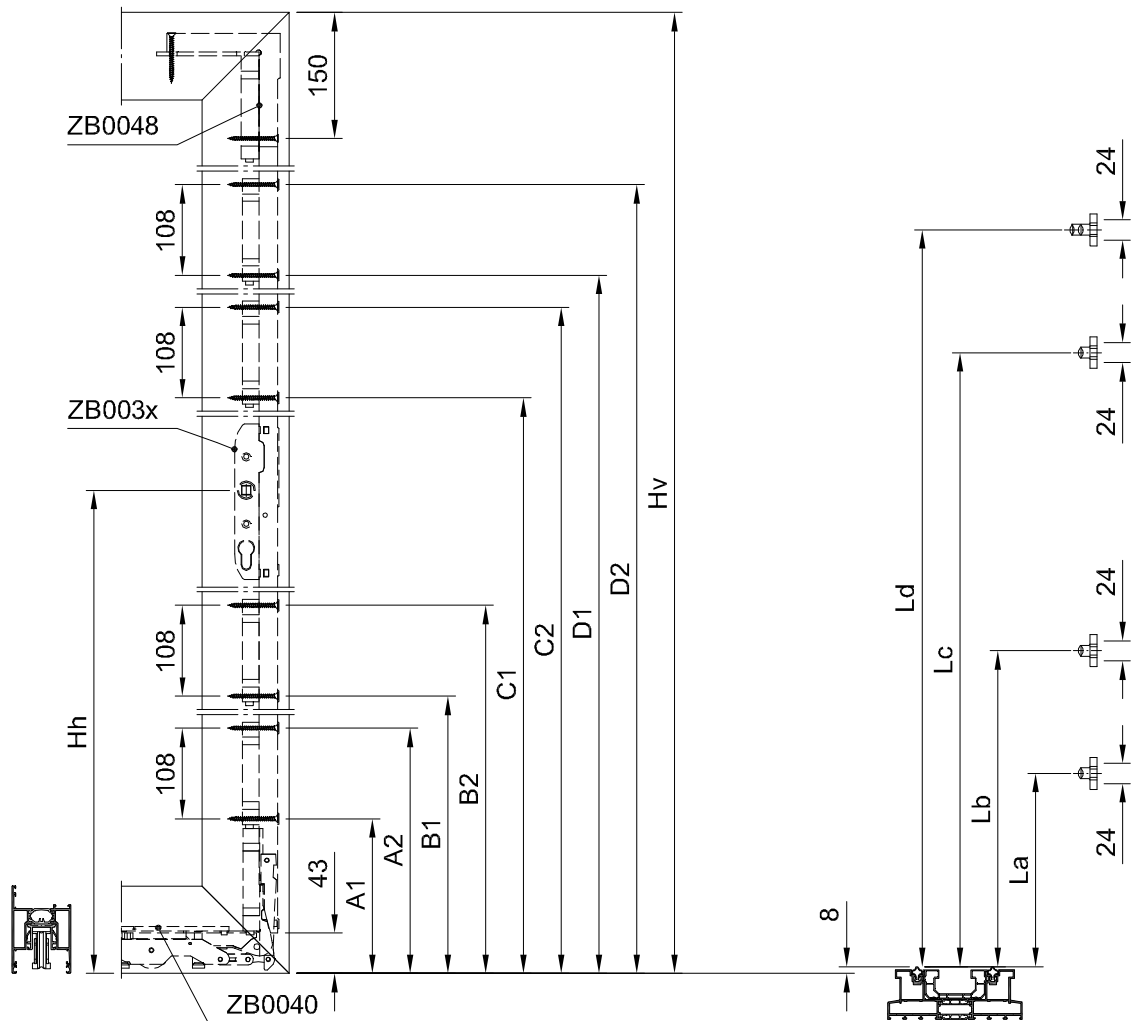
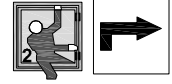

Hv			Hh	A		B		C		D		E	F		L				
min	max			A1	A2	B1	B2	C1	C2	D1	D2		F1	F2	La	Lb	Lc	Ld	Lf
1312	2009	ZB0033	403		-	-	-	554	662	954	1062					-	600	1000	
2010	2309	ZB0034	1003	204	312	704	812	1154	1262	1554	1662	-	-	-	250	750	1200	1600	
2310	2609	ZB0035								1854	1962							1900	
2610	2909	ZB0036								2154	2262							2200	
2910	3209	ZB0035 + ZB0046	Vedi Pagina 4 / 4																
3210	3509	ZB0035 + ZB0046																	

C160-ASS-3102









**Allegati**



**LIMITI DI IMPIEGO - ALZANTE-SCORREVOLE**

**2 ANTE CON C9V001**

W (DAN/M <sup>2</sup> )	80	120	160	200	$f \leq H/300$
	1 C2	2 C3	3 C4	4 C5	$F_{max} \leq 8 \text{ mm}$

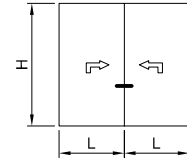
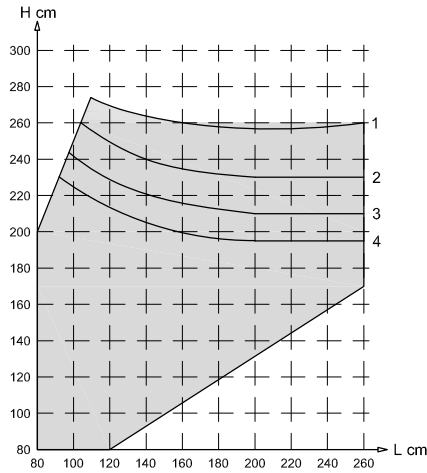
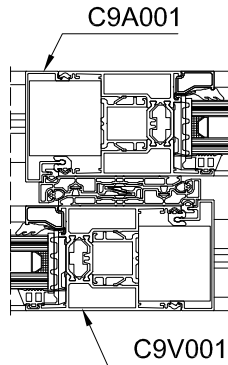

 max. 300 kg/  
(400 kg)

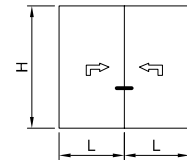
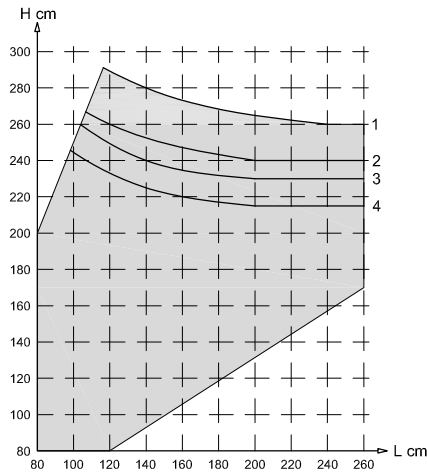
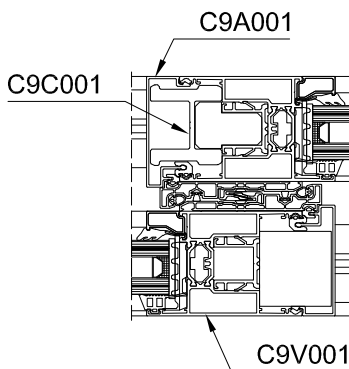

 max. 300 kg/  
(400 kg)

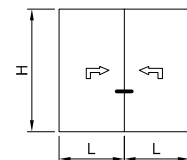
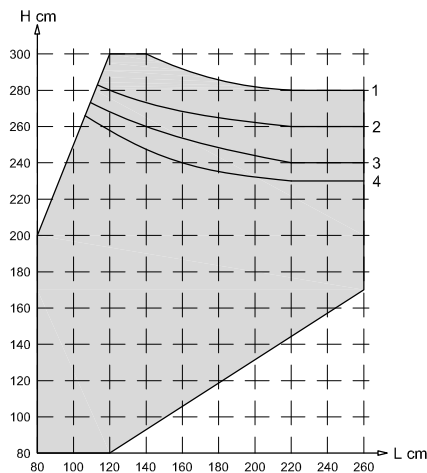
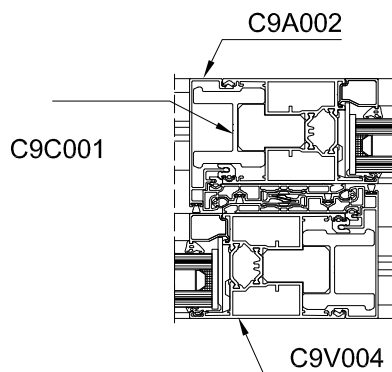

 max. 300 kg/  
(400 kg)

**2 ANTE CON C9V051**

W (DAN/M <sup>2</sup> )	80	120	160	200	$f \leq H/300$
	1	2	3	4	F <sub>max</sub> ≤ 8 mm
	C2	C3	C4	C5	

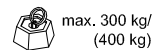
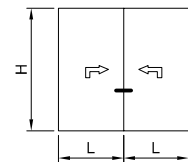
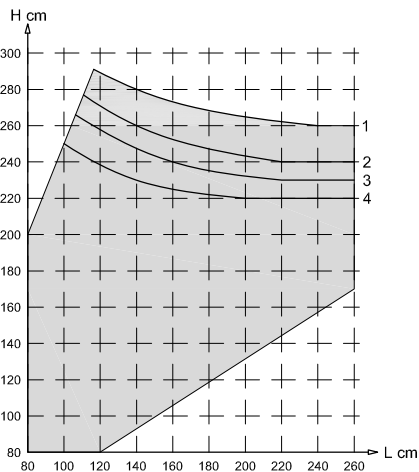
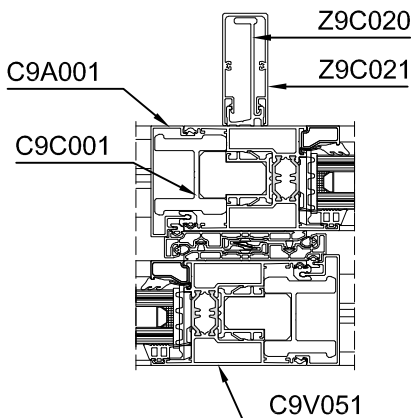
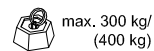
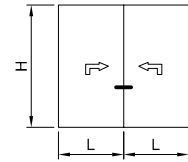
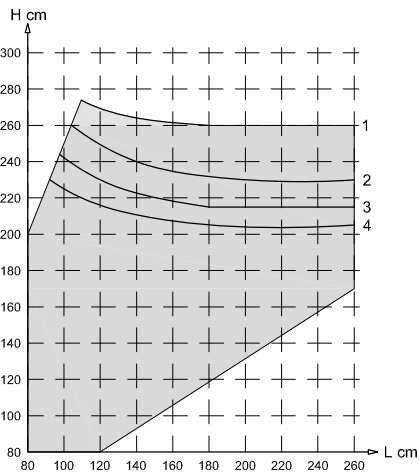
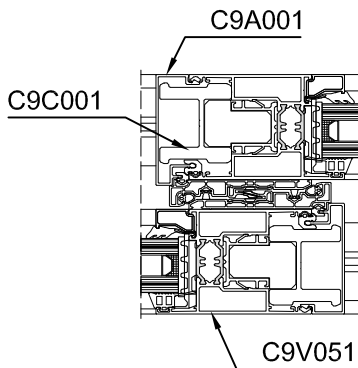
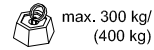
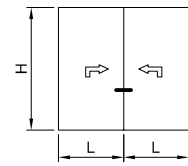
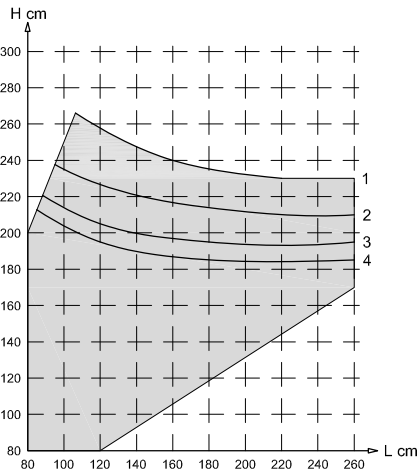
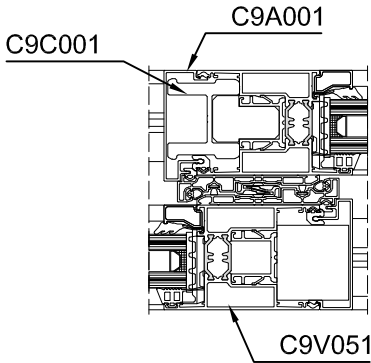



LIMITI DI IMPIEGO - ALZANTE-SCORREVOLE

4 ANTE

<b>W (DAN/M<sup>2</sup>)</b>	<b>80</b>	<b>120</b>	<b>160</b>	<b>200</b>	$f \leq H/300$
	1	2	3	4	$F_{max} \leq 8 \text{ mm}$
	C2	C3	C4	C5	

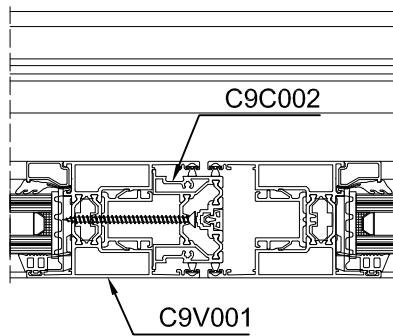
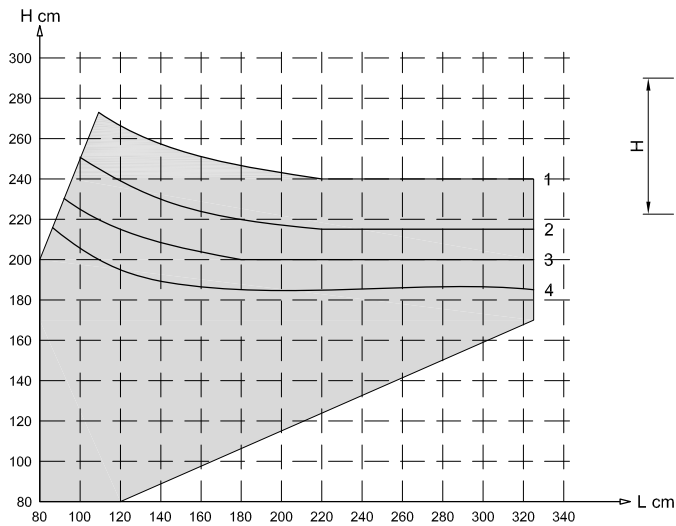





**VALORE UF DI FINESTRE E PORTE**

La trasmittanza termica  $U_w$  dei serramenti nel loro complesso (telaio e vetratura) può essere calcolata con la procedura di calcolo semplificata descritta nella norma EN ISO 10077-1 che tiene conto della trasmittanza termica del telaio, del vetrocamera o del pannello e della trasmittanza termica lineare del distanziatore tra le due lastre vetrate del vetrocamera:

$$U_w = \frac{U_f A_f + U_g A_g + U_p A_p + \Psi_g L_g + \Psi_p L_p}{A_f + A_g + A_p} \left[ \frac{W}{m^2 K} \right]$$

dove:

- $A_f$  area del telaio in  $m^2$  definita come l'area della proiezione della superficie del telaio su un piano parallelo al vetro. Corrisponde all'area più grande tra l'area della superficie frontale interna  $A_{f,i}$  e l'area della superficie frontale esterna  $A_{f,e}$ ;
- $U_f$  trasmittanza termica del telaio metallico in  $W/m^2K$ .
- $A_g$  area della vetratura in  $m^2$ ;
- $U_g$  trasmittanza termica dell'elemento vetrato in  $W/m^2K$ ;
- $U_p$  trasmittanza termica del pannello opaco in  $W/m^2K$ ;
- $A_p$  area del pannello in  $m^2$ ;
- $L_g$  perimetro della vetratura in metri; se il perimetro visto dall'interno differisce da quello visto dall'esterno deve essere assunto il valore maggiore delle lunghezze perimetrali;
- $L_p$  perimetro del pannello opaco in metri;
- $K_l$  trasmittanza lineare in  $W/mK$  (da considerarsi solo nel caso del vetro camera) dovuta alla presenza del distanziatore posto tra i due vetri; si ricava in funzione del tipo di vetro e del materiale del telaio; tale valore si considera nullo per vetri singoli. Questo parametro è introdotto per tenere conto della *dispersione termica perimetrale* che si verifica in prossimità del bordo del vetrocamera per la presenza del distanziatore.
- $K_p$  trasmittanza termica lineare in  $W/mK$ . Può essere calcolata secondo la metodologia descritta dalla norma UNI EN ISO 10077-2. Questo valore può essere posto uguale a zero quando:
  - le superfici interne ed esterne del pannello sono di materiale con conduttività termica inferiore a 0,5  $W/mK$ ;
  - la conduttività termica di qualsiasi materiale di collegamento al bordo del pannello è inferiore a 0,5  $W/mK$ .

Con calcolo semplificato può essere valutata anche la trasmittanza termica di serramenti doppi  $U_{wD}$  (costituiti cioè da telai fissi separati):

$$U_{wD} = \frac{1}{\frac{1}{U_{w1}} - R_{SI} + R_S + R_{SE} + \frac{1}{U_{w2}}} \left[ \frac{W}{m^2 K} \right]$$

dove:

- $U_{w1}$  trasmittanza termica del serramento esterno calcolata secondo la prima formula, in  $W/m^2K$ .
- $U_{w2}$  trasmittanza termica del serramento interno calcolata secondo la prima formula in  $W/m^2K$
- $R_{SI}$  resistenza termica superficiale interna del serramento esterno quando previsto da solo.
- $R_{SE}$  resistenza termica superficiale esterna del serramento interno quando previsto da solo.
- $R_S$  resistenza termica dello spazio compreso tra le vetrazioni dei due serramenti in  $m^2K/W$

Con calcolo semplificato può essere valutata anche la trasmittanza termica di **serramenti accoppiati**  $U_{wA}$  (caratterizzati dalla presenza di un telaio fisso unico):

$$U_{wD} = \frac{1}{\frac{1}{U_{G1}} - R_{SI} + R_S + R_{SE} + \frac{1}{U_{G2}}} \left[ \frac{W}{m^2 K} \right]$$

dove:

- $U_{G1}$  trasmittanza termica della vetratura esterna
- $U_{G2}$  trasmittanza termica della vetratura interna
- $R_{Si}$  resistenza termica superficiale interna della vetratura esterna quando applicata da sola.
- $R_{SE}$  resistenza termica superficiale esterna della finestra interna
- $R_s$  resistenza termica dello spazio compreso tra la vetratura esterna e quella interna del serramento accoppiato in  $m^2K/W$ .

La resistenza termica di una lastra di vetro è fortemente influenzata dalle resistenze superficiali sia interne sia esterne, di conseguenza la presenza di elementi di schermatura contribuisce a modificare lo scambio termico (e conseguentemente tali valori di resistenza liminare) aumentandone la sua resistenza termica.

Pertanto è possibile considerare per i serramenti una *resistenza termica aggiuntiva* che tiene conto della presenza di schermi esterni (tapparelle, persiane, ecc.) e della permeabilità all'aria del serramento. Si esprime cioè la prestazione termica dei serramenti a schermi chiusi tramite la cosiddetta trasmittanza termica notturna  $U_{ws}$ :

$$U_{ws} = \frac{1}{\frac{1}{U_w} + \Delta R} \quad \frac{W}{m^2 K}$$

dove:

- $U_w$  trasmittanza termica del serramento in  $W/m^2K$ ;
- $\Delta R$  resistenza termica aggiuntiva in  $m^2K/W$  dovuta alla presenza degli schermi chiusi il cui valore può essere definito in funzione della permeabilità e della resistenza termica  $R_{sh}$  degli schermi.

Per la valutazione del contributo delle chiusure oscuranti si può far riferimento alla procedura descritta nella norma EN ISO 10077-1.

## TABELLA DI CONTROLLO DEL SERRAMENTO FINITO

Posizione	Caratteristica da esaminare	Requisito	Metodo di prova	Tolleranze
1	Dimensioni telaio	Documenti di commessa	Metro	$\pm 0.5 \text{ mm}$
2	Dimensioni ante	Istruzioni di lavorazione	Metro	$\pm 0.5 \text{ mm}$
3	Angoli	Istruzioni di lavorazione	Goniometro	$\pm 0.5^\circ$
4	Taglio guarnizioni	Istruzioni di lavorazione	Documenti di produzione	$L \times 1.01 \pm 2 \text{ mm}$
5	Montaggio guarnizioni	Istruzioni di lavorazione	Visivo	
6	Sigillatura giunzioni	Istruzioni di lavorazione	Visivo	
7	Numero di drenaggi	Istruzioni di lavorazione	Visivo	
8	Fori di ventilazione	Istruzioni di lavorazione	Visivo	
9	Posizionamento vetrocamera	Istruzioni di lavorazione	Documenti di produzione	
10	Componenti della ferramenta	Completezza	Visivo	
11	Posizionamento della ferramenta	Istruzione di montaggio	Visivo	
12	Regolazione della ferramenta	Istruzione di montaggio	Calibro a corsoio	
13	Funzionamento ferramenta	Istruzione di montaggio	Prova di funzionamento	

## CONDIZIONI GENERALI DI VENDITA

### 1. Premessa

- Le presenti condizioni generali di vendita si applicano integralmente ad ogni ordine e a tutte le nostre vendite, salvo stipulazione contraria che deve risultare espressamente e per iscritto da parte della nostra Società.

- L'invio o la consegna di qualsiasi ordine di acquisto da parte dell'Acquirente alla nostra Società implica l'accettazione integrale e senza riserve da parte sua delle condizioni generali di vendita della nostra Società.

- Le presenti condizioni generali sono riportate in ogni modulo di conferma d'ordine, nei manuali, anche informativi, nei cataloghi e nel sito della nostra Società e si considerano conosciute da tutti i Compratori.

### 2. Offerte

- Le offerte formulate dalla nostra Società sono senza impegno e non valgono quale proposta.

- Le offerte sono subordinate alle condizioni generali di vendita.

- Le condizioni generali di vendita sono riportate nella nostra offerta e s'intendono accettate mediante invio o consegna dell'Ordine/Commessa.

### 3. Ordini/Commesse

- Ogni ordine/commessa formulato dall'Acquirente è soggetto ad accettazione scritta (c.d. Conferma) da parte della nostra Società ed implica l'accettazione delle condizioni generali della nostra Società.

- Gli ordini devono essere completi e definiti in ogni loro parte mediante Distinta inviata a mezzo fax o e-mail.

- La trasmissione dell'ordine impegna l'Acquirente ai dati contenuti nella propria scheda commerciale consegnatagli da nostro delegato e comunque, se non diversamente specificato per iscritto, ai prezzi, alle condizioni di listino ed alle condizioni generali di vendita della nostra Società in vigore alla data di conferma d'ordine.

- Eventuali richieste di variazioni, modifiche o cancellazione dell'ordine da parte dell'Acquirente sono soggette ad approvazione da parte della nostra Società e dovranno pervenire unicamente e inderogabilmente entro 12 ore lavorative dall'invio dell'ordine solo a mezzo e-mail o fax.

- Le 12 ore verranno calcolate considerando data e ora indicata sulla e-mail/fax dell'invio ordine e sulla e-mail/fax di richiesta cancellazione/variazione.

- In caso di variazioni dell'ordine la nostra Società si riserva la facoltà di ritardare i tempi di consegna e di modificare il prezzo.

### 4. Conferme d'Ordine

-La Conferma d'Ordine della nostra Società giungerà all'Acquirente a mezzo e-mail, fax, posta, o a mano.

- La Conferma d'Ordine inviata dalla nostra Società definisce e riporta tutte le condizioni e i contenuti definitivi e vincolanti del Contratto, sostituendosi integralmente all'ordine/commessa.

- La Conferma d'Ordine e le presenti condizioni generali di contratto prevarranno in ogni caso su eventuali condizioni generali o particolari di acquisto predisposte dall'Acquirente.

- Qualsiasi condizione scritta o verbale inviata da parte di nostri collaboratori, funzionari di vendita dipendenti della nostra Società o agenti di vendita è priva di valore se non riprodotta nel testo della nostra conferma d'ordine o se non confermata per iscritto dalla nostra Società.

### 5. Oggetto del contratto

- Il contratto ha ad oggetto la fornitura dei materiali, per i quantitativi specificati nella nostra Conferma d'Ordine o in ogni eventuale successiva modifica trasmessa via fax, mail o a mani dalla nostra Società.

- Non rientrano nell'oggetto del presente contratto con la nostra Società i campioni di materiale e i prototipi da sottoporre a prove e/o a test, tutte le informazioni rese in qualsiasi forma o sede per le lavorazioni dei nostri prodotti, quali ad esempio proposte di calcoli, di progetti, di disegni, informazioni relative all'assemblaggio, all'installazione, alla lavorazione, alle verifiche statiche, all'offerta per gare d'appalto; pertanto non ci assumiamo alcuna responsabilità per le fasi di lavorazione successive alla fornitura dei nostri prodotti, anche con riguardo alla loro interazione con altri prodotti.

- In ogni caso, le dimensioni, gli schemi di montaggio e di lavorazione, i prezzi, le prestazioni e gli altri dati figuranti nei cataloghi, nei manuali di lavorazione, nei prospetti, negli annunci pubblicitari, nelle illustrazioni, nei listini prezzi, od in altri documenti illustrativi della nostra Società, così come le caratteristiche dei modelli e campioni inviati dalla nostra Società all'Acquirente, hanno carattere di mere indicazioni, non saranno vincolanti e non contengono alcuna promessa di qualità in relazione ai prodotti.

Tali dati non hanno valore impegnativo se non sono espressamente richiamati nella Conferma d'ordine.

- La nostra Società si riserva di apportare in qualunque momento ai propri prodotti quelle modifiche tecniche non sostanziali, dettate da esigenze di produzione, che riterrà convenienti, senza obbligo di comunicazione.

### 6. Prezzi

- I prezzi delle nostre merci si intendono sempre Porto Franco (DDP per gli Incoterms), salvo diversa pattuizione tra le parti. I pagamenti e ogni altra somma dovuta a qualsiasi titolo alla nostra Società si intendono netti al domicilio della nostra Società.

- Eventuali pagamenti fatti ad agenti, rappresentanti, funzionari di vendita, dipendenti o collaboratori della nostra Società non saranno considerati validi fino a quando le relative somme non giungeranno alla nostra Società.

- I prezzi applicati sono quelli indicati nel listino prezzi della nostra Società valido al momento della consegna dei nostri prodotti allo spedizioniere, oltre alle rispettive imposte sul valore aggiunto, salvo diversa indicazione da provarsi per iscritto contenuta nella nostra Conferma d'ordine o in altro documento da noi proveniente.

### 7. Condizioni di pagamento

- Il pagamento dovrà essere effettuato, salvo diverso accordo scritto, a fine mese dalla data della fattura o entro il diverso termine indicato nella fattura, a mezzo di ricevuta bancaria, bonifico bancario presso l'istituto bancario indicato dalla nostra Società o tramite rimessa diretta. Vale quale consegna della merce il ritiro della merce da parte dello spedizioniere o il ritiro autonomo della merce da parte dell'Acquirente se concordato tra le parti.

- La nostra Società si riserva di chiedere degli acconti sul prezzo da versare al momento della conclusione del contratto o successivamente.

### 8. Ritardati pagamenti

- In caso di ritardato, mancato o parziale pagamento da parte dell'Acquirente, la nostra Società si riserva il diritto di sospendere immediatamente la fornitura, e/o di risolvere tutti i contratti in essere con l'Acquirente, anche se non relativi al

pagamento in questione, fatto salvo il diritto al risarcimento del danno.

- In caso di ritardato, mancato o parziale pagamento, su tutte le somme dovute matureranno interessi di mora calcolati ai sensi dell'art. 5, comma 2, del decreto legislativo 9 ottobre 2002, n. 231 ("Attuazione della direttiva 2000/35/CE relativa alla lotta contro i ritardi di pagamento nelle transazioni commerciali" pubblicato nella Gazzetta Ufficiale n. 249 del 23 ottobre 2002) senza necessità di messa in mora e tutti i crediti diventeranno immediatamente esigibili con decadenza dal beneficio del termine.

- Nessuna contestazione per eventuali inadempimenti, né eccezione alcuna, né azioni legali di qualsiasi natura potrà essere sollevata od esercitata dall'Acquirente se non previo integrale pagamento del prezzo.

- Non è ammessa alcuna compensazione fra il prezzo dovuto alla nostra Società ed eventuali crediti vantati dall'Acquirente.

- L'Acquirente è obbligato al pagamento integrale del prezzo anche in caso di contestazioni.

### 9. Consegna

- Salvo patto contrario, la fornitura della merce si intende Porto Franco.

- E' facoltà della nostra Società effettuare forniture parziali e/o consegne ripartite della merce.

- I termini di consegna indicati nella Conferma d'Ordine non sono termini essenziali, salvo diverso accordo. La forza maggiore o altre circostanze eccezionali o imprevedibili che si verificassero nei confronti della nostra Società o dei nostri fornitori (quali a mero titolo di esempio scioperi, blocchi stradali, etc. etc.) sospendono i termini per la consegna, senza alcuna responsabilità per la nostra Società.

- Qualora vi sia un ritardo nella consegna della merce superiore ai 30 (trenta) giorni, che non dipenda da forza maggiore o da eventi imprevedibili, è fatto obbligo all'Acquirente contestare per iscritto tale ritardo alla nostra Società, la quale avrà un termine di ulteriori 30 (trenta) giorni per effettuare la consegna. Nessun diritto al risarcimento del danno spetterà all'Acquirente.

- In caso di consegne ripartite, valgono le disposizioni che precedono.

- La nostra Società non risponde per danni da anticipata o ritardata consegna, totale o parziale.

### 10. Rischio di perimento della merce

- Il rischio del perimento o della rovina della merce passa in capo all'Acquirente al più tardi quanto la stessa merce lascia gli stabilimenti della nostra Società ovvero alla consegna. A seguito del passaggio dei rischi la nostra Società non risponde del perimento o della rovina della merce.

- In caso di ritardo da parte dell'Acquirente di presa in consegna della merce, il rischio, qualora non sia già passato in capo all'Acquirente ai sensi del capoverso precedente, si trasmetterà allo stesso alla data di consegna prevista.

- L'Acquirente è obbligato al pagamento integrale del prezzo in caso di danneggiamento o perimento della merce avvenuto dopo il passaggio allo stesso dei rischi.

### 11. Verifiche

- E' fatto obbligo all'Acquirente di verificare la conformità della merce e l'assenza di vizi entro 8 (otto) giorni dal ricevimento, e comunque prima di effettuare qualsiasi lavorazione aggiuntiva sulla stessa.

- Eventuali contestazioni saranno considerate valide solo se comunicate per iscritto mediante raccomandata a.r. entro 8 (otto) giorni dalla ricezione della merce.

- Eventuali vizi occulti dovranno essere denunciati per iscritto, mediante raccomandata a.r., entro 8 (otto) giorni dalla scoperta.

- In ogni caso nessuna denuncia per vizi, difetti o non conformità sarà valida se effettuata oltre un anno dalla consegna.

- Eventuali denunce dovranno essere dettagliate e specifiche, indicare esattamente i difetti riscontrati e, su richiesta della nostra Società, dovranno anche comprendere la restituzione del prodotto difettoso a proprie spese, al fine di consentire le verifiche del caso.

### 12. Garanzie

- La nostra Società garantisce la conformità dei prodotti: per conformità dei prodotti si intende che essi corrispondano per qualità e tipo a quanto stabilito nel contratto e che siano esenti da vizi che possano renderli non idonei all'uso cui sono destinati. I campioni, le indicazioni contenute nei depliant o le informazioni risultanti da altro materiale pubblicitario non sono vincolanti e non contengono alcuna promessa di qualità in relazione ai prodotti.

- La nostra Società non si assume alcuna responsabilità circa la conformità del prodotto alla normativa di Paesi stranieri ove sarà utilizzato il prodotto o destinato, circa eventuali usi speciali, circa gli usi abitualmente previsti nel Paese di destinazione.

- La garanzia avrà una durata di un anno dalla consegna.

- Sulle quantità l'Acquirente riconosce alla nostra Società di accettare quantità di fornitura determinate dalle minime quantità produttive nel caso di ordini riferiti a prodotti non disponibili a magazzino e a multipli interi delle unità di vendita per quanto concerne i materiali gestiti a magazzino.

- La garanzia per i vizi è limitata ai soli vizi dei prodotti dipendenti da difetti di materiale o di lavorazione riferibili alla nostra Società, e non si applica in caso di difetti di installazione o non corretto uso da parte dell'Acquirente. Sarà onere dell'Acquirente fornire alla nostra Società la prova di aver effettuato una corretta installazione o uso.

- La garanzia non si estende a difetti che siano riconducibili a richieste dell'Acquirente, a richieste di imprese terze incaricate dello stesso, alle lavorazioni successive, all'assemblaggio, all'installazione, alle caratteristiche della struttura, o ad altre cause che non sono oggetto della nostra fornitura.

- La nostra Società non risponde dei difetti di conformità dovuti all'usura normale di quelle parti che, per loro natura, sono soggette ad una rapida e continua usura.

- In generale, in nessun caso la nostra Società risponde per difetti di conformità che abbiano la loro causa in un fatto successivo al passaggio dei rischi all'Acquirente ai sensi dell'art. 10.

### 13. Contenuto della garanzia

- In caso di contestazione dei vizi nei termini e con le modalità di cui all'art. 11, la nostra Società eseguirà una verifica del prodotto in contestazione non appena lo stesso verrà inviato presso il nostro stabilimento, a spese dell'Acquirente; in caso di impossibilità di spedizione, la nostra Società effettuerà sopralluogo, a spese dell'Acquirente. All'esito delle verifiche la nostra Società redigerà un verbale contenente il dettaglio degli accertamenti eseguiti.

- Nel caso in cui saranno accertati dalla nostra Società i vizi o i difetti contestati, provvederemo, gratuitamente, a nostra discrezione:

a) alla riparazione;

b) alla sostituzione mediante la fornitura gratuita Porto Franco dei prodotti dello stesso genere e quantità di quelli risultati non conformi o difettosi, entro un termine ragionevole. Prima della sostituzione della merce l'Acquirente dovrà restituirci la merce difettosa.

- La sostituzione s'intende solo in relazione al singolo pezzo danneggiato e non all'intera partita.

- Non è dovuto alcun risarcimento danni; in particolare l'Acquirente non potrà avanzare altre richieste di risarcimento del danno, di riduzione del prezzo o di risoluzione del contratto.

- In nessun caso la nostra Società risponde per danni indiretti o consequenziali, per danni da mancata o ridotta produzione, anche rispetto a già pattuiti termini di consegna.

### 14. Riserva di proprietà

- La merce resta di proprietà della nostra Società fino al completo pagamento del prezzo.

- Nel caso venga esercitata la riserva di proprietà da parte della nostra Società, l'Acquirente presta fin da ora il consenso a consentirci l'accesso presso i luoghi dove è depositata la merce e il diritto a ritirare la merce di nostra proprietà.

- Fino a quando sussiste la riserva di proprietà è fatto divieto all'Acquirente, senza il consenso scritto della nostra Società, di costituire pegno o di vendere a terzi la merce di nostra proprietà.

- E' fatto obbligo all'Acquirente di comunicarci tempestivamente per iscritto eventuali pignoramenti o sequestri della merce di nostra proprietà e di dichiarare all'Ufficiale Giudiziario il nostro diritto di proprietà sulla suddetta merce, al fine di consentirci di esercitare le azioni legali necessarie.

- In caso di omessa o mancata tempestiva comunicazione, le spese legali relative ai procedimenti da noi sostenuti saranno a carico dell'Acquirente.

### 15. Divieto di cessione

- Il presente contratto e i diritti da esso derivanti non potranno, in tutto o in parte, essere ceduti dall'Acquirente, senza il consenso scritto della nostra Società.

### 16. Forma, esclusività e nullità

- Qualsiasi modifica al presente contratto non sarà valida se non fatta per iscritto ed approvata dalla nostra Società.

- L'eventuale nullità di una qualsiasi delle clausole previste nel presente contratto non comporterà la nullità dell'intero contratto, il quale andrà integrato ed interpretato nella sua globalità. Le parti si impegnano a sostituire la clausola nulla o inefficace con una clausola che tenga conto e consenta di realizzare lo scopo economico che le parti, il contratto e le condizioni generali si erano prefissati.

### 17. Obbligo di riservatezza

- L'Acquirente si obbliga a mantenere riservate tutte le notizie e le informazioni di carattere tecnico (disegni, prospetti tecnici, documentazione, formule, corrispondenza etc.) ricevute dalla nostra Società o apprese in esecuzione del presente contratto.

### 18. Risoluzione

- La nostra Società potrà risolvere il presente contratto, senza preavviso, mediante dichiarazione della propria volontà di risoluzione, comunicata per iscritto alla Società acquirente mediante raccomandata a.r., fax o mail, al verificarsi di uno dei seguenti eventi:

a) il mancato pagamento, parziale o totale, di quanto dovuto dalla Società acquirente secondo i tempi e le modalità previste nel presente contratto, salvo che la nostra Società non si avvalga della facoltà di chiedere l'adempimento del contratto, in ogni caso con pagamento dell'importo stabilito nel presente contratto, e previa determinazione dei termini delle consegne ripartite, oltre al risarcimento del danno;

b) In caso di dichiarazione di fallimento della Società acquirente o nel caso in cui la stessa venga sottoposta ad una procedura concorsuale;

c) in tutti gli altri casi previsti dagli artt. 1453 e segg. del codice civile.

### 19. Legge applicabile

- Per tutto quanto non espressamente previsto dalle presenti condizioni generali si applica la legge italiana e gli artt. 1470 e seguenti del codice civile italiano.

### 20. Foro competente

- Per tutte le controversie che dovessero sorgere in relazione all'esistenza, validità interpretazione, esecuzione e risoluzione del presente contratto sarà competente in via esclusiva il Foro di Milano.

### 21. Comunicazioni

- Tutte le comunicazioni riguardanti questo contratto devono essere fatte per iscritto, e si intenderanno validamente effettuate se inviate a mezzo raccomandata a.r. o a mezzo e-mail certificata ai seguenti indirizzi: Sapa Building Systems S.p.A, Via Ponchielli 3, 20063 Cernusco sul Naviglio (MI) - [sapabuildingsystems@peccasapaystems.it](mailto:sapabuildingsystems@peccasapaystems.it)

### 22. Privacy

- Ai sensi del D.Lgs. n.196 del 30.6.2003 entrambe le Società dichiarano di aver ricevuto informativa, ed autorizzano fin da ora ogni trattamento nonché comunicazione e diffusione dei dati, anche sensibili, necessari per la conclusione del presente Contratto di fornitura.

- Entrambe le parti si impegnano altresì a provvedere a propria cura e spese ad ogni adempimento del sopra citato decreto legislativo per soggetti terzi di propria competenza che, nel corso del rapporto contrattuale di cui trattasi, dovesse rendersi necessario per l'espletamento dell'incarico ricevuto.

### 23. Norme tecniche e responsabilità del produttore

- Per ciò che concerne le caratteristiche dei prodotti della nostra Società, essi sono conformi alla legislazione, alle norme tecniche vigenti in Italia e alle norme di prodotto specifiche al momento della conclusione del contratto.

- L'Acquirente si assume per intero il rischio di un'eventuale difformità tra le norme italiane e quelle del Paese di destinazione dei prodotti, tenendo indenne la nostra Società da ogni eventuale richiesta di risarcimento danni o sanzione o altra conseguenza economica.

- La nostra Società garantisce le prestazioni dei prodotti di sua fabbricazione solo ed esclusivamente in relazione ad usi, destinazioni, applicazioni, tolleranze da essa espressamente indicati.

- L'Acquirente non è autorizzato a disporre dei prodotti forniti dalla nostra Società in modo non conforme alle indicazioni di cui al punto precedente.





Sapa Building Systems S.p.A..  
Via A. Ponchielli 3, 20063  
Cernusco sul Naviglio (MI)  
T: + 02 92 42 91  
F: 02 92 42 94 96  
[www.domal.it](http://www.domal.it)

