

Sistema R^{TT}

R 50^{TT}
SYSTEM

Sistema Rtt, per porte e finestre si è arricchito dei più avanzati contenuti estetici, tecnologici e funzionali atti a soddisfare tutte le esigenze costruttive e progettuali.

Rtt System for windows and doors, has been enriched of the most esthetical, technological and functional contents to fulfill all the construction and designing demands.

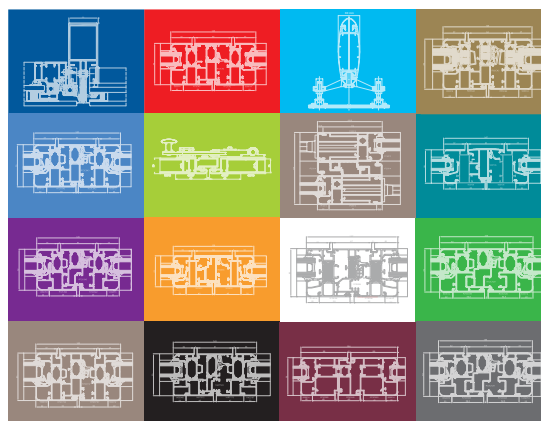

sapa:

R | 50^{TT}
SYSTEM

Finestre e porte a battente a taglio termico
Casement windows and doors with thermal break

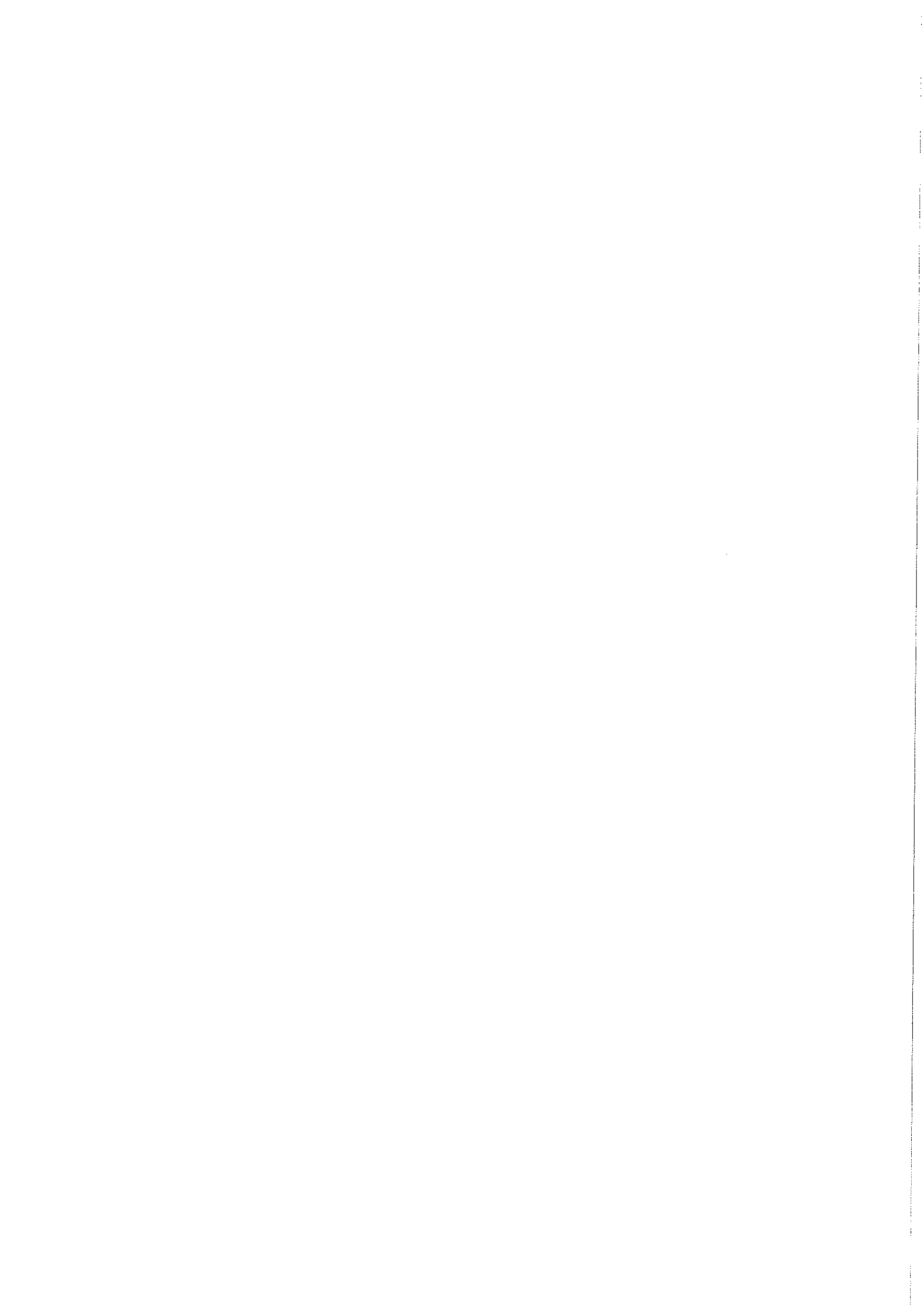

About the Sapa Group

Sapa develops, manufactures and markets value added profiles, profile-based building systems and heat-exchanger strip in the light-weight material aluminium and is one of the world's leading manufacturers.

Sapa's business concept is based on close co-operation with its customers, who are primarily located in Europe, North America and Asia. The largest customer segments are the construction, transport, domestic and office, and engineering sectors.

Sapa is organised into six Business Areas: Profiles North Europe, Profiles Central Europe, Profiles South Europe, Profiles North America, Building System and Heat Transfer.

Sapa Profiles

Sapa is the world's leading producer of extruded aluminium profiles and maintains extensive operations in the value-added fabrication of profiles.

The company has 111 presses and more than 12.000 employees and production facilities in 18 countries: Belgium, China, Denmark, France, Germany, Hungary, Italy, Lithuania, Mexico, the Netherlands, Poland, Portugal, Romania, Slovakia, Spain, Sweden, the United Kingdom and the United States, plus sales representation in a number of additional countries.

With footprints in North and Central America, Europe and Asia we can serve customers on a worldwide basis.

Sapa Profili Srl

With 3 plants in Italy and the support of the rest of the group, Sapa Profili Srl is one of the largest extrusion companies within Italy.

Soft- and hard-alloy aluminium extrusions, standard rod and bars, seamless tube (round or shaped), simple or complex aluminium extrusion profiles (drawings), high fin ratio, tight tolerances with superior surface finish quality, or other demanding high-tech applications... There is a simple solution to almost any design problem: aluminium profiles by Sapa. The solutions are based on our unique experience in extrusion and our focus on the local market.

Sapa Profili Srl strategy is providing its customers with expertise, high quality and resources, releasing capacity to allow them to concentrate on their core operations. It's all about creating competitive, comprehensive solutions.

Il gruppo Sapa

Sapa sviluppa, produce e commercializza profili a valore aggiunto, profili per l'edilizia e scambiatori di calore in alluminio. Sapa è un leader tra i produttori nel mondo.

Un elemento determinante per il concetto di business di Sapa è la stretta collaborazione con il cliente maggiormente basati in Europa, Nord America ed Asia. I segmenti di mercato maggiori sono quelli dell'edilizia, il settore trasporti, casa ed uffici ed il settore della meccanica.

La Sapa è suddivisa in sei aree: Profili Nord Europa, Profili Europa centrale, Profili Sud Europa, Profili Nord America, Sistemi per l'edilizia ed il settore per gli scambiatori di calore.

Sapa Profili

Sapa è il maggior produttore di profili estrusi al mondo.

Questa nuova azienda dispone di 111 presse con oltre 12.000 dipendenti e con centri di produzione in 18 paesi: Belgio, Cina, Danimarca, Francia, Germania, Ungheria, Italia, Lituania, Messico, Olanda, Polonia, Portogallo, Romania, Slovenia, Spagna, Svezia, Gran Bretagna e negli stati uniti oltre ad avere rappresentanti commerciali in altri paesi.

Grazie alla presenza in America del Nord e Centrale, Europa ed Asia, possiamo servire i clienti in tutto il mondo.

Sapa Profili Srl

Con i 3 stabilimenti produttivi in Italia ed il supporto del resto del gruppo la Sapa Profili Srl diventa uno dei maggiori estrusori in Italia.

Estrusioni di alluminio in lega leggera o dura, profili standard o barrame, tubi tondi o a disegno senza saldature, profili estrusi semplici o complessi a disegno, elevato rapporto di atletatura, tolleranze ristrette con qualità superficiale elevata o qualsiasi altra esigenza per applicazioni high tech... esiste una semplice soluzione a quasi tutte le esigenze di design: profili in alluminio Sapa. Le soluzioni basano sulla nostra esperienza unica e focalizzata sul mercato locale..

La strategia di Sapa Profili Srl è quella di fornire al cliente competenza, qualità superiore e risorse, per permettere loro di concentrarsi sulle proprie operazioni essenziali. Plasmiamo il futuro creando soluzioni comprensive e competitive.



Innovation and Experience: Sapa keys to Build The future

Since its beginnings Sapa has been recognized as an innovator. Through the years, we've balanced experience with innovation. We've listened to our customers, and we are dedicated to providing the tools our customers need to succeed.

Following this spirit, in the market of B&C Sapa offers a comprehensive line of architectural aluminum building products and systems for residential and non-residential buildings framing systems, windows and curtain wall systems.

Due to the accurate product design, in the B&C market, the Sistema R allows the realization of windows and doors with the less possible manufacturing, reducing so the assembling time and achieving the best quality.

This system is present in the South European market since more than 20 years and has allowed Sapa to renovate it constantly with the experience acquired. In this way the Sistema R, the most widespread for windows and doors on the Italian market, has evolved with the most advanced esthetical and technological contents, as to satisfy all planning demands.

For this reason Sapa has realized, within the Sistema R, four continuous bar thermal break series with different sections and performances, all defined in dimensional, technological and esthetical versatility.



Innovazione ed esperienza: le chiavi Sapa per costruire il futuro.

Fin dalle sue origini, Sapa è stata riconosciuta come innovatrice. Attraverso gli anni, abbiamo equilibrato l'esperienza con l'innovazione. Abbiamo ascoltato i nostri clienti e ci siamo dedicati a fornir loro i mezzi necessari per avere successo.

Seguendo questo spirito, nel mercato dell'edilizia, Sapa offre una completa linea di prodotti architettonici in alluminio e sistemi strutturali per edifici residenziali e non, finestre e pareti divisorie.

Nel mercato dell'edilizia, Il sistema R, grazie all'attenta progettazione, consente di realizzare serramenti in alluminio con il minor numero di lavorazioni possibili, riducendo i tempi di assemblaggio nel rispetto della migliore qualità.

La pluri decennale presenza sul mercato sud europeo di questo sistema ha permesso a Sapa di rinnovarlo costantemente nel tempo utilizzando l'esperienza acquisita negli anni. In questo modo il sistema R, il più diffuso e venduto, per porte e finestre, sul mercato italiano, si è arricchito dei più avanzati contenuti estetici, tecnologici e funzionali atti a soddisfare tutte le esigenze costruttive e progettuali.

Per questo Sapa ha realizzato, all'interno del sistema R, quattro serie di profilati a taglio termico a barra continua con diverse sezioni e prestazioni, tutte caratterizzate da polivalenza dimensionale, tecnologica ed estetica.



Original Systems®
sapa:

Le serie dei sistemi di Sapa

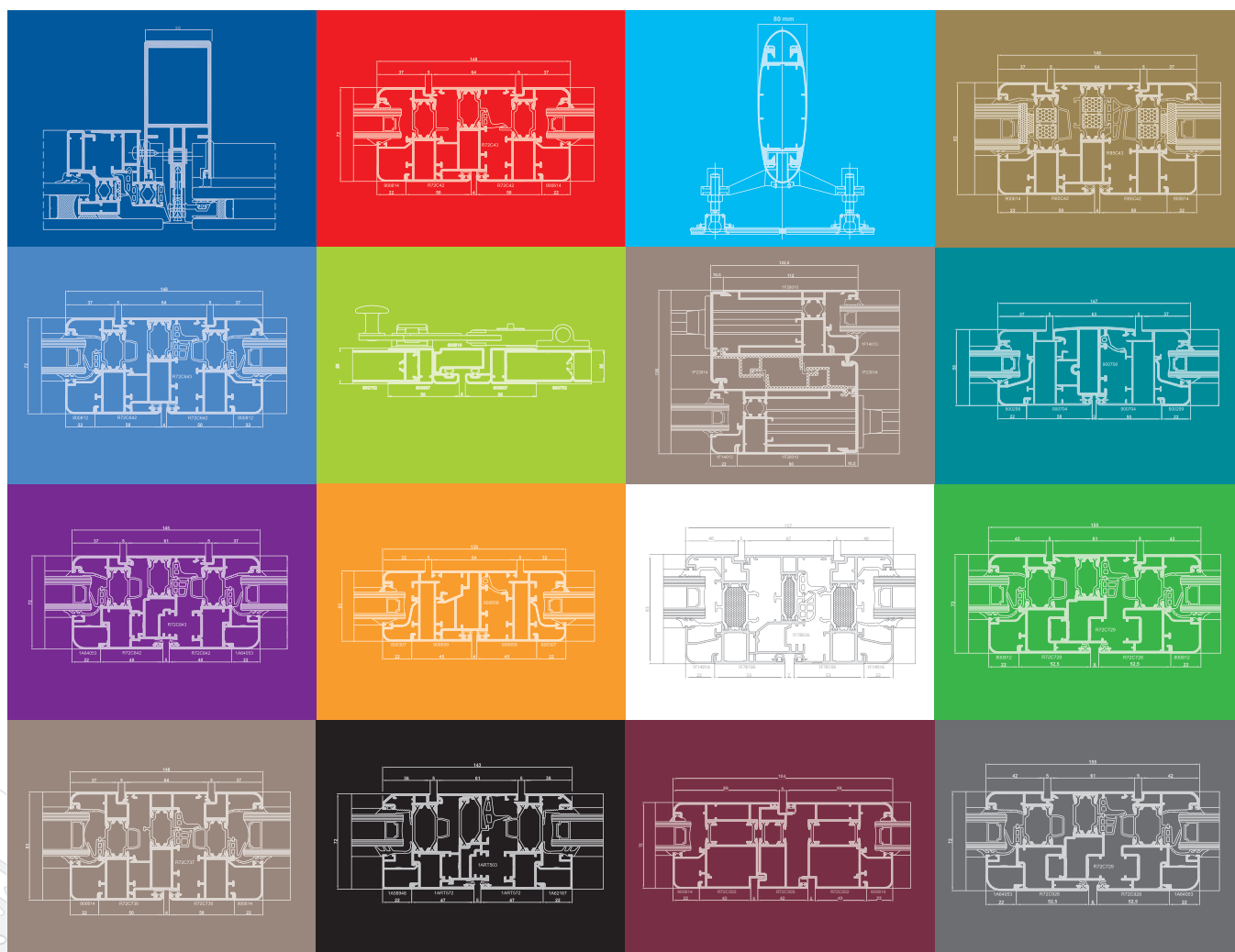

Scegliere con **serenità**

sapa:
Creiamo il futuro

sapa:

Original Systems®

... scegliere con serenità

Original Systems Sapa non è soltanto un profilo in alluminio: è una soluzione completa per tutti gli attori della filiera, con l'obiettivo di fornire il miglior prodotto, col più alto valore aggiunto, dalla bauxite al serramento.

L'assistenza tecnica pre e post vendita, i certificati delle prestazioni dei serramenti, la formazione della Scuola del Serramento di Bareggio (MI), i software di calcolo, le soluzioni Autocad, gli opuscoli tecnici, i cataloghi, la comunicazione ed una capillare e competente Rete di Distribuzione Original Systems Sapa vi danno la serenità di aver fatto la scelta migliore.

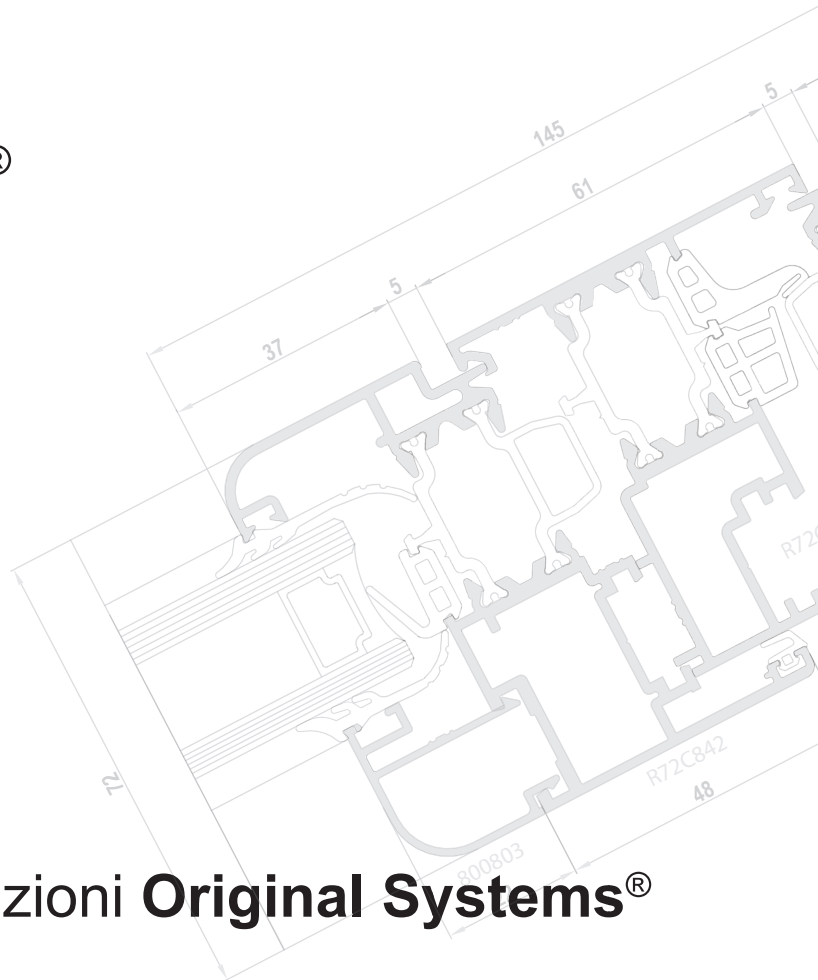

soluzioni Original Systems®

Sistema R^{TT}

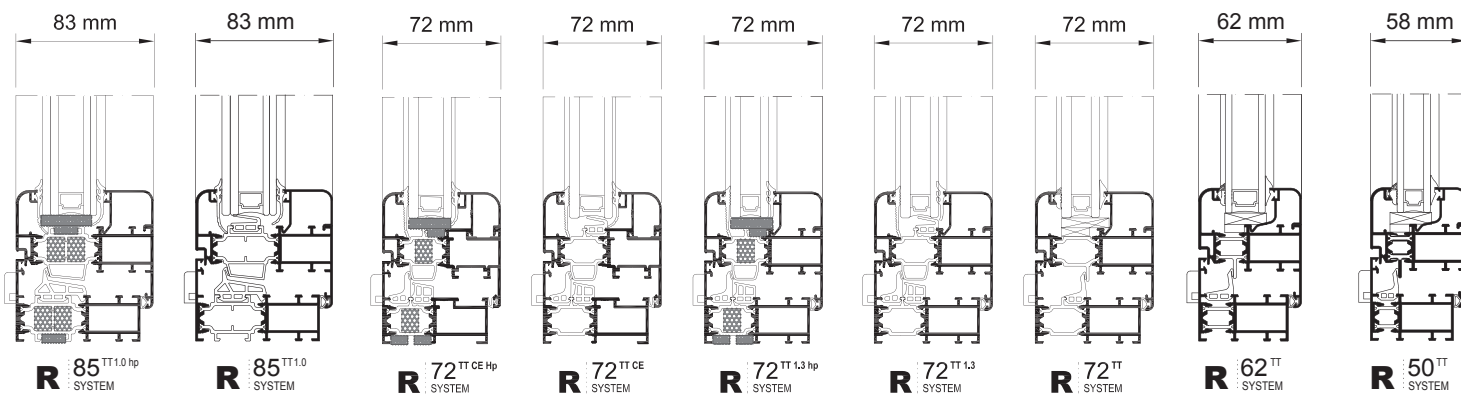

Alfil *next*

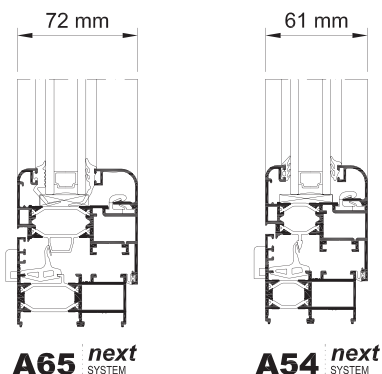

Sistema R

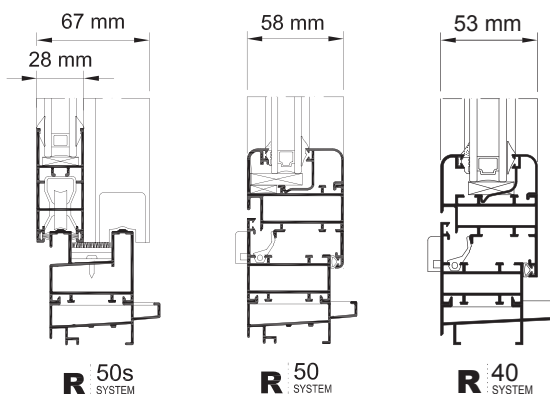

Mr. Hide SYSTEM

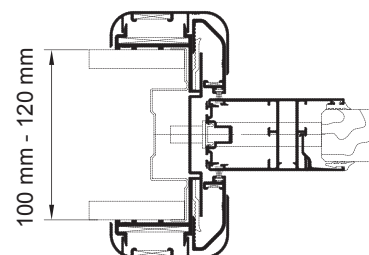

Teknowindow Battente

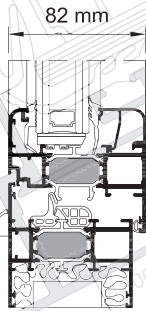

WIN 82su^{TT}
SYSTEM

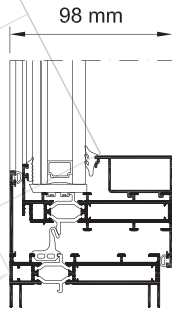

WIN 70^{TT}
SYSTEM

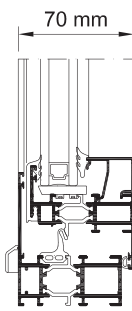

WIN 70^{TT}
SYSTEM

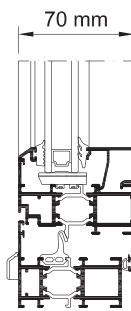

WIN 70^{TT}
SYSTEM

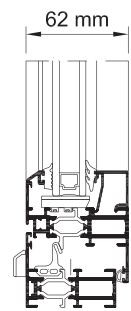

WIN 62^{TT}
SYSTEM

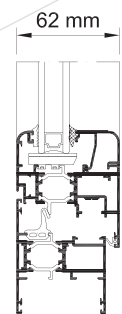

WIN 62^{PTT}
SYSTEM

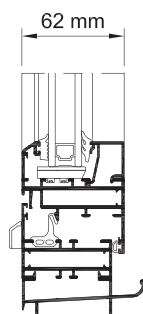

WIN 62
SYSTEM

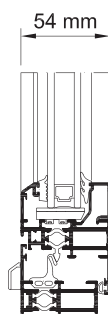

WIN 54^{TT}
SYSTEM

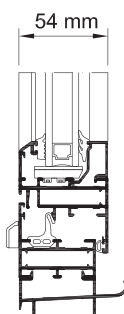

WIN 54
SYSTEM

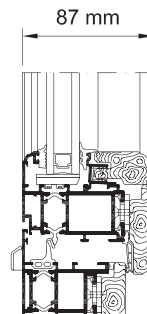

WIN LIGNUM^{TT}
SYSTEM

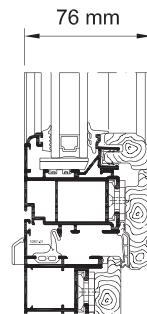

WIN LIGNUM
SYSTEM

Teknowindow Scorrevole

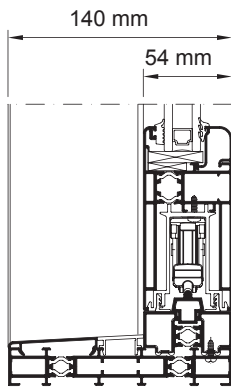

WIN 140sa^{TT}
SYSTEM

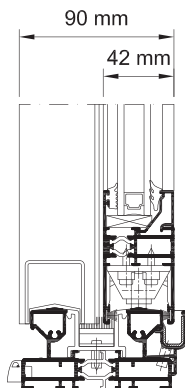

WIN 90s^{TT}
SYSTEM

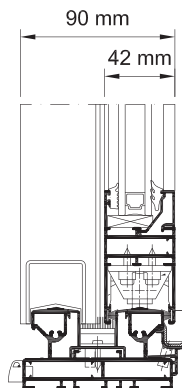

WIN 90s
SYSTEM

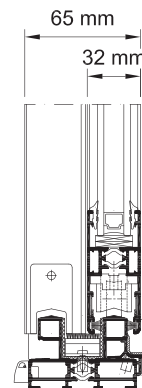

WIN 65s^{TT}
SYSTEM

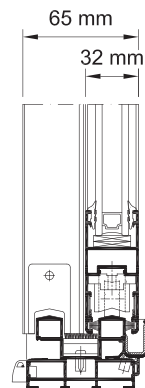

WIN 65s
SYSTEM

Sistemi Oscuranti

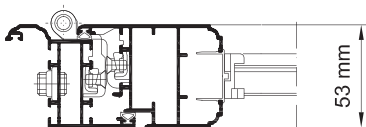

Persiane

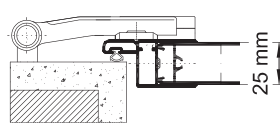

Scurone Venezia

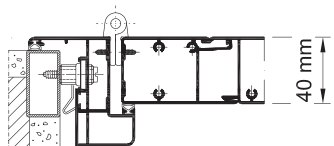

Scurone Padova

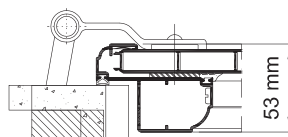

Scurone Romagna

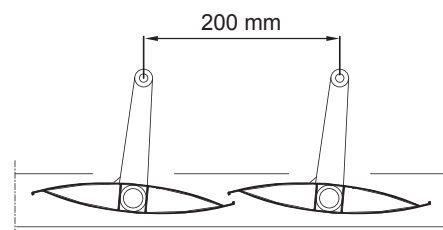

Frangisole

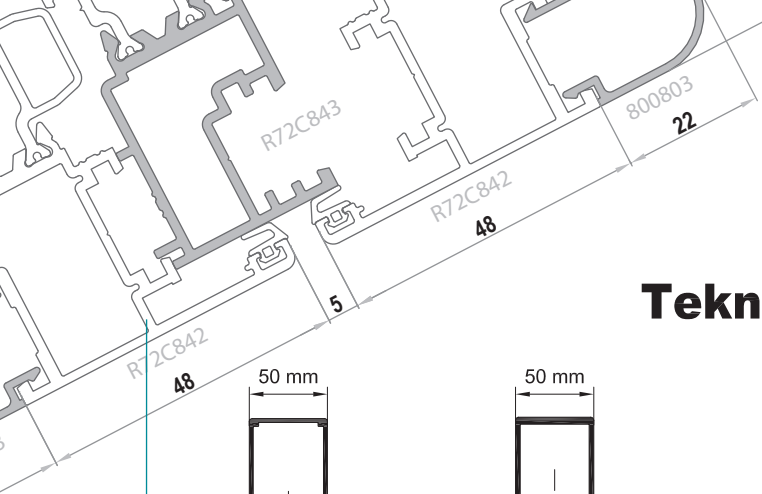

Teknowall

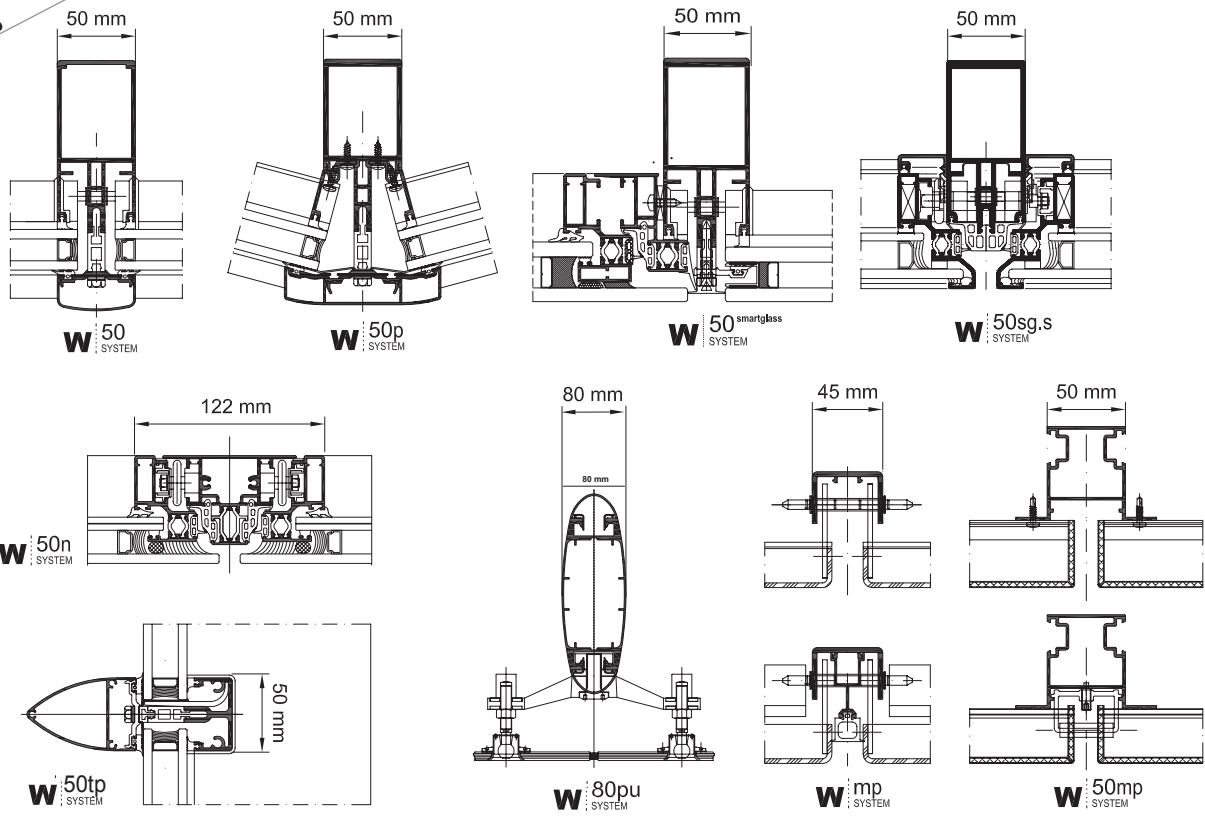

Portoni

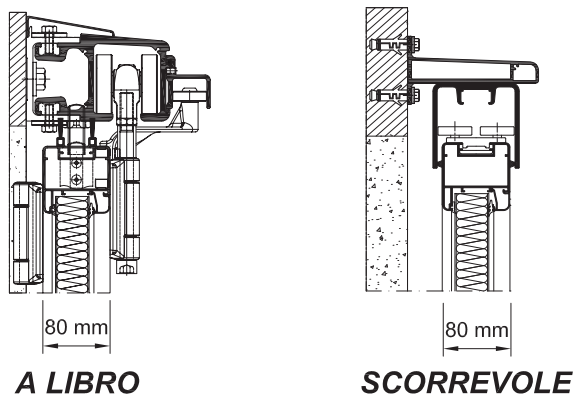

Veranda a Libro

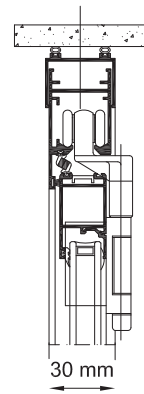

GR 14 SYSTEM

plus® SYSTEM

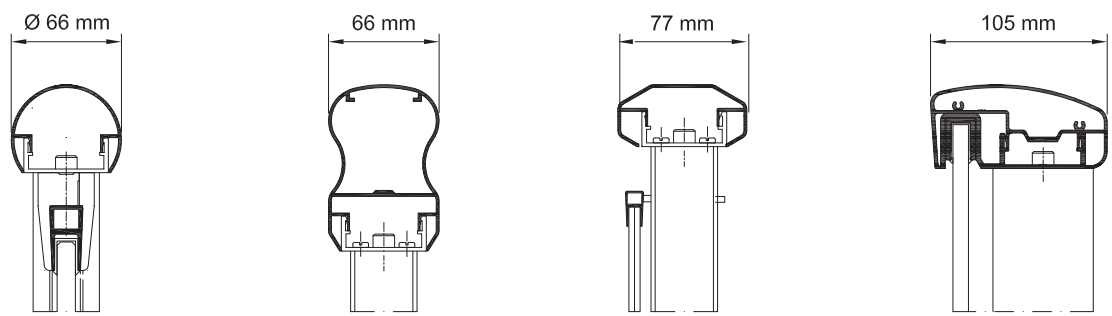

RINGHIERE E BALCONI

Il sistema

Il Sistema R a taglio termico è composto da sei serie di profilati:
R50TT, con telaio fisso da 50 mm ed anta mobile da 58 mm
R62TT, con telaio fisso da 54 mm ed anta mobile da 62 mm
R72TT, con telaio fisso da 64 mm ed anta mobile da 72 mm
R72TT1.3, con telaio fisso da 64 mm ed anta mobile da 72 mm
R72TTCE, sistema a "Camera Europea", con telaio fisso da 64mm ed anta mobile da 72mm
R85TT1.0, con telaio fisso da 75 mm ed anta mobile da 83 mm

I Profilati:

Estrusi in lega di alluminio primario da lavorazione plastica EN AW 6060 UNI-EN 573-3 sottoposti ad un processo di trattamento termico applicato secondo Normativa UNI EN 755-2 (bonifica con tempra in aria alla pressa, seguita da invecchiamento artificiale) per ottenere lo stato T5. Per dettagli tecnici vedere pagina F1-T50-A-08

Trattamenti superficiali:

I trattamenti superficiali di ossidazione anodica, elettrocolorazione e di verniciatura eseguiti negli impianti di proprietà Sapa, sono nel rispetto di quanto previsto dalle normative richieste dai marchi Qualanod (per ossidazione) e Qualicoat (per la verniciatura).

Vetratura:

La scelta ed il tipo di vetro sarà in funzione del suo campo di impiego, per il montaggio attenersi scrupolosamente alle prescrizioni dei produttori.

Il Sistema consente l'inserimento di vetri aventi spessori da 6 a 39 mm per R50TT; da 10 a 43 mm per R62TT; da 20 a 53 mm per R72TT ed R72TT 1.3; da 14 a 52 per R72TT CE; da 26 a 62 per R85TT 1.0.

Le guarnizioni di tenuta vetro sono in EPDM ed inseribili e sostituibili a serramento assemblato, studiate in vari spessori che, interpolati nel modo idoneo, garantiscono un'adeguata compressione sulla lastra di vetro. La tassellatura sarà effettuata con appositi tasselli di regolazione e spessoramento aventi posizioni nel serramento ideali e rinforzate. Solo la completa e totale osservanza della tecnica di vetratura potrà garantire uno scatto vincolante e sicuro del fermavetro e la garanzia di durata agli sforzi di normale utenza.

Calcolo dimensioni massime serramenti:

Nel definire le misure massime dei diversi tipi di serramento, si devono considerare oltre agli elementi costruttivi dell'infisso (sezione dei profili e loro campi d'impiego, tipo di attacco al muro, spessore e tipo del vetro), le caratteristiche di utilizzo, nonché le varianti metereologiche (esposizione dell'infisso, velocità dei venti agenti nella zona, altezza dal suolo alla quale sarà installato l'infisso, ecc.).

Consigliamo a tal fine la consultazione delle prescrizioni Uncsaal.

Attrezzature:

Le attrezzature raccomandate (Comall e Tekna) sono state appositamente progettate e realizzate per le particolari caratteristiche del sistema e per l'applicazione specifica degli accessori a catalogo.

Peso dei profilati:

I pesi indicati sono puramente indicativi (peso teorico ricavato sullo spessore nominale del profilato); Le matrici di estrusione sono soggette ad un normale processo di usura che porta il peso dell'estruso da un minimo (matrice nuova) ad un massimo (matrice usurata al limite delle tolleranze dimensionali).

Tolleranze dimensionali

Per le tolleranze dimensionali si fa riferimento alla Normativa UNI EN 12020-2

NB:

Il mancato impiego, anche parziale, dei prodotti originali, esclude qualsiasi possibilità di rivalsa nei confronti di Sapa.

Al fine di migliorare i propri prodotti, Sapa si riserva la facoltà di apportare, in qualsiasi momento e senza preavviso, le modifiche che riterrà opportuno.

I dati riportati su questo catalogo sono indicativi e non impegnativi.

The system

The thermal break R system is made up of six series of section bars:
R50TT, with 50 mm fixed frame and 58 mm moving shutter
R62TT, with 54 mm fixed frame and 62 mm moving shutter
R72TT, with 64 mm fixed frame and 72 mm moving shutter
R72TT1.3, with 64 mm fixed frame and 72 mm moving shutter
R72TTCE, "European Chamber" system, with 64 mm fixed frame and 72 mm moving shutter
R85TT1.0, with 75 mm fixed frame and 83 mm moving shutter

The sections

These are extruded in primary aluminium alloy from EN AW 6060 UNI-EN 573-3 plastic manufacturing, subject to a thermal treatment, applied according to UNI EN 755-2 regulation (austempering through air tempering at the press, followed by artificial ageing) in order to achieve the T5 physical state.

For technical detail refer to page F1-T50-A-08

Surface treatments:

The surface treatments of anodization, electrocoloration and painting carried out in Sapa Italy plants, respect the regulations required by the brands: Qualanod (for anodization) and Qualicoat (for painting).

Glazing:

The choice and the type of glass will depend on its final use. While assembling, it is essential to follow scrupulously the manufacturers' instructions.

With this System it is possible to insert glass with thickness of 6 to 39 mm for R50TT; 10 to 43 mm R62TT; 20 to 53 mm for R72TT and R72TT 1.3; 14 to 52 for R72TT CE; 26 to 62 for R85TT 1.0.

The weatherstrips for the glass containment is in EPDM and is conceived in different thickness. If interpolated in the correct way, it assures a proper compression on the glass.

The plugging will be carried out through proper adjusting and shimming plugs, located in ideal and reinforced positions in the fastening. Only the full respect of the glazing technique will assure the proper functioning of the glass beading and will guarantee a long term resistance to the normal uses.

Window maximum dimensions

During the definition of the maximum dimensions of the different sorts of windows, beside the structural elements of the frame (section, uses, juncture to the wall, thickness and sort of glass), the final use and the weather conditions (exposure of the window frame, speed of the wind in the area, distance from the ground where the frame will be installed, etc.) have to be taken into account.

To this purpose, we suggest to consult the Uncsaal regulations.

Equipment:

The recommended equipment (Comall and Tekna) has been planned and realized on purpose according to the particular characteristics of the system and to the specific application of the catalogue accessories.

Weight

Any weight is shown just as an indication (theoretical weight made out of the nominal thickness of the section) The extrusion dies are subject to the natural wear and tear, therefore the section weight varies from a minimum when the dies is new, to a maximum weight when the die is at highest dimensional tolerances limits.

Dimensional allowance

As for the dimensional allowance it is to refer to UNI EN 12020-2 Regulation.

NB:

Sapa declines any responsibility in case of use or partial use of non original products.

With the aim of improving it's products, Sapa reserves the possibility to make changes to this document at any moment and with no advise.

The data reported in this catalogue are indicative and not binding.

L'esecuzione del serramento dovrà prevedere tutte le operazioni necessarie per il buon funzionamento del "componente finestra" quali la sigillatura e il bloccaggio sicuro degli angoli, il fissaggio a muro adeguato e, necessariamente, l'utilizzo di accessori e guarnizioni originali. Le lavorazioni, proprio per garantire la giusta applicazione dei particolari, dovranno essere eseguite con attrezzature originali e collaudate sul sistema stesso. Gli scarichi dell'acqua e le asole di aerazione per vetri camera dovranno essere di dimensione e numero ottimale in funzione della dimensione e della tipologia del serramento.

The frame construction must include all the operations necessary for good working of the "window component", such as sealing and safe blocking of corners, suitable wall fixtures and the use of the original accessories and weatherstrips. In order to guarantee the correct application of the parts, works must be carried out with original equipment that has been tested on the system. The size and number of water drains and ventilation slots for double glazing must correspond to the size and type of window frame.

Attenzione

Nelle porte a taglio termico, nei casi in cui ci sia un'eccessiva variazione di temperatura, si possono generare, sulle ante, fenomeni di deformazione dovuta alla diversa dilatazione tra profilato esterno e profilato interno, con conseguente difficoltà di chiusura dell'anta stessa.

Ciò accade perché il sole riscalda i profilati esterni del serramento provocandone la dilatazione che risulta essere differente da quella del profilato interno non riscaldato dal sole, questo provoca delle tensioni che fanno deformare il profilato anta curvandolo verso l'esterno.

Non avendo più l'allineamento anta/telaio si hanno problemi di chiusura, nelle ore di maggiore esposizione si può riscontrare il bloccaggio e/o l'impossibile chiusura della porta.

Questo fenomeno si evidenzia in particolar modo quando si hanno porte d'ingresso con tamponamenti ciechi.

Ad oggi non esistono sistemi a taglio termico che risolvano totalmente il problema. Stiamo studiando, in collaborazione con i maggiori produttori di barrette, soluzioni che possano risolvere questo fenomeno nel prossimo futuro.

Oggi, per ridurre il problema, si possono adottare accorgimenti da valutare di volta in volta.

Attention

In case of sensitive variations of temperature in the Thermal break door solution, deformation of the wings can take place due to the diversified expansion of the internal and external profiles. This can bring to a difficult closing of the wing itself.

Deformation takes place because the sun heats the external profile of the window causing a dilatation which is different from the one of the internal profile. This causes tension that curve the wing profile to the external part. As the wing and the frame are no longer aligned there could be some difficulty in closing the doors. In the hottest hours of the day the door could stall, or it could be impossible to lock the door.

This phenomena is more common when the doors have non glass closures. Up to today there are no thermal break door systems which do not present this problem, although we are studying alternative solutions together with the biggest suppliers of polyamide bars.

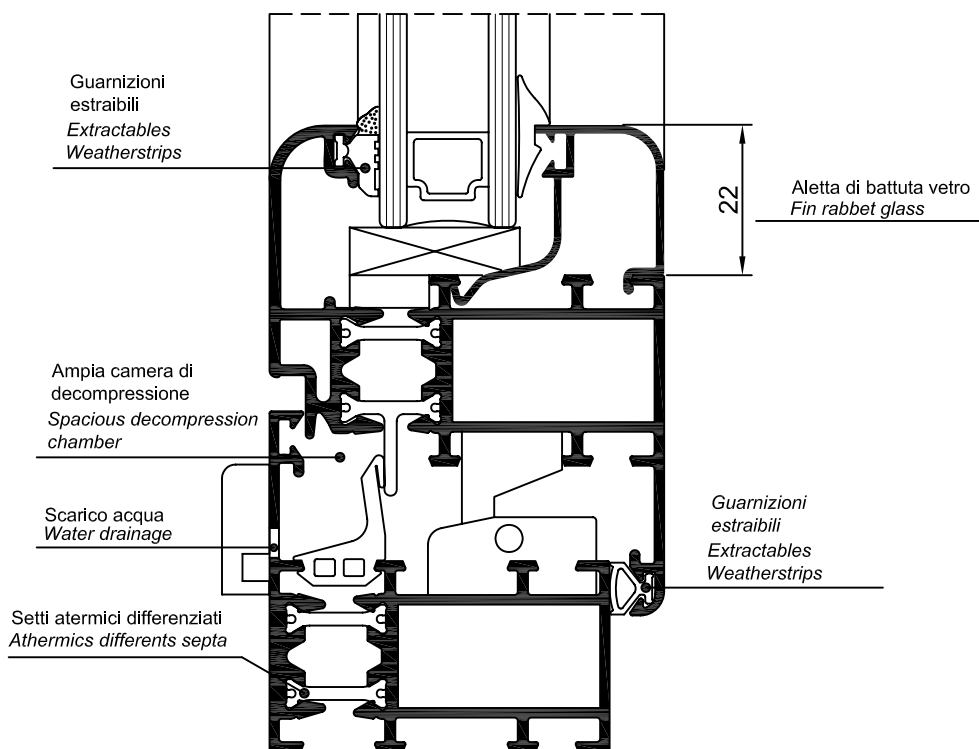

ACCESSORI E GUARNIZIONI

ACCESSORIES AND PACKING

Originali e marcati Sapa, con corpo in lega di alluminio, perni e viteria in acciaio inox, le boccole e i particolari di scorrimento sono in poliammide rinforzato. Le guarnizioni in EPDM sono state studiate con durezza differenti secondo la funzione che dovranno svolgere all'interno del serramento.

They are original and Sapa marked. Their features are: core in aluminium alloy, pins and screw in stainless steel, bushings and sliding elements are in reinforced polyamide. The packing in EPDM has been conceived in different hardness according to its functions in the fastening.

Per garantire il massimo delle prestazioni in funzionalità e durata, il sistema RTT è stato sottoposto ai collaudi rescritti dalle vigenti Normative europee ottenendo ottimi risultati

To guarantee the maximum functionality and wear, R system has been tested according to the running european norms.

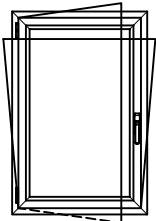
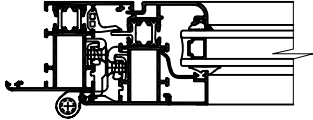
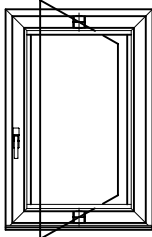
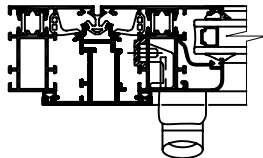
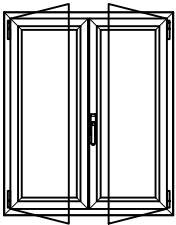
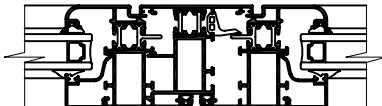
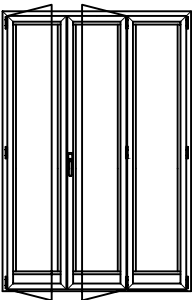
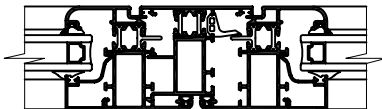
CERTIFICATI		CERTIFICATES					
Sistema System	Tipologia Windows and doors	Dimensioni Dimensions L x H mm	Risultati prove Test values			Sezioni Cross section	Laboratorio Certificato N° Laboratory Certificate Nr.
			Aria Air	Acqua Water	Vento Wind		
R 50 ^{TT} SYSTEM		1054 x 1402	4	E1050	C5		ISTEDIL 0868/2008-A
R 50 ^{TT} SYSTEM		1400 x 2200	4	E750	C5		ISTEDIL 1448/2008-H
R 50 ^{TT} SYSTEM		1514 x 1684	4	E750	C4		ISTEDIL 0683/2002-D
R 50 ^{TT} SYSTEM		1839 x 2217	4	9A	C4		ISTEDIL 0868/2008

- Collaudi classificati secondo Normative UNI EN 12207 -
 UNI EN 12208 - UNI EN 12210

- Tests Classify as UNI EN 12207 - UNI EN 12208 -
 UNI EN 12210 standards

Tecnicamente, viene definito "a taglio termico" un profilato metallico che, una volta impiegato nella costruzione di un infisso, presenti il lato rivolto all'interno nettamente diviso dal lato esposto all'esterno per impedire lo scambio termico. Le due parti della sezione devono essere perciò separate da un materiale diverso, con bassi valori di conducibilità termica.

Il taglio termico del sistema R, realizzato con barrette in poliammide rinforzato, si colloca su bassi valori di trasmittanza termica, in linea con i sistemi a taglio termico più avanzati.

Per evitare slittamenti dei vari componenti del profilato a taglio termico è prescritta la pre-zigrinatura dei particolari di bloccaggio prima dell'operazione meccanica di accoppiamento.

A metal section which, when used in the construction of a frame, has the side facing inwards clearly divided from that facing outwards to prevent heat exchange is technically defined "with thermal break". The two parts of the section must therefore be separated by a different material, with low conductivity values.

The thermal break of the R system, produced with reinforced polyamide bars, is placed on low k values (heat transmission coefficient), in line with the most advanced systems with thermal break.

To prevent the components of the thermal break section from slipping, it is advisable to pre-knurl the blocking parts before carrying out the mechanical coupling operation.

Tutti i profilati a taglio termico venduti da Sapa sono sempre riconoscibili.

Il marchio, impresso a laser è stato previsto per essere sempre visibile nel profilato assemblato come dalla figura sottostante

All thermal break sections are always recognizable.

The laser impressed brand is always visible on the assembled sections as you can see in the picture here under

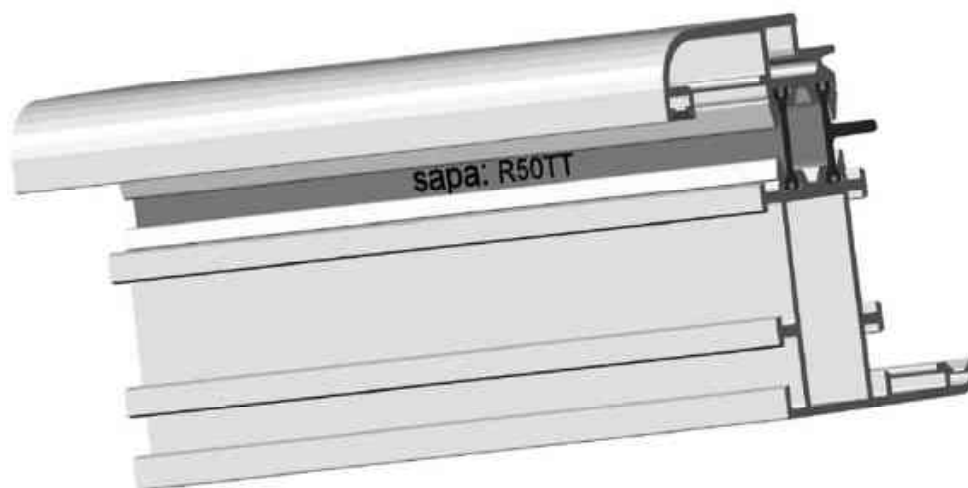

Sapa non risponde di eventuali difetti imputabili ad accoppiamenti non eseguiti nei propri stabilimenti e/o dovuti all'utilizzo di macchine non idonee e/o mal regolate.

Sapa will not be responsible for any incidental defects due to couplings which have not been carried out in its own premises and/or due to the use of not proper and/or not well-regulated machines.

"Valido solo per il territorio ITALIANO"

"Applicable only for Italy"

Requisiti della prestazione energetica degli edifici

Decreto legislativo 29 dicembre 2006, n. 311

Disposizioni correttive ed integrative al decreto legislativo 19 agosto 2005, n. 192, recante attuazione alla direttiva 2002/91/CE, relativa al rendimento energetico nell'edilizia.

Stabilisce i valori massimi della trasmittanza termica dei vetri e delle chiusure trasparenti comprensive di vetri e profilati metallici.

Tabella 4a Valori limite della trasmittanza termica U delle chiusure trasparenti comprensive degli infissi espressa in W/m ² K			
Zona climatica	Dall' 1 gennaio 2006 U (W/m ² K)	Dall' 1 gennaio 2008 U (W/m ² K)	Dall' 1 gennaio 2010 U (W/m ² K)
A	5,5	5,0	4,6
B	4,0	3,6	3,0
C	3,3	3,0	2,6
D	3,1	2,8	2,4
E	2,8	2,4	2,2
F	2,4	2,2	2,0

Tabella 4b Valori limite della trasmittanza U dei vetri espressa in W/m ² K			
Zona climatica	Dall' 1 gennaio 2006 U (W/m ² K)	Dall' 1 luglio 2008 U (W/m ² K)	Dall' 1 gennaio 2011 U (W/m ² K)
A	5,0	4,5	3,7
B	4,0	3,4	2,7
C	3,0	2,3	2,1
D	2,6	2,1	1,9
E	2,4	1,9	1,7
F	2,3	1,7	1,3

Il territorio nazionale è suddiviso nelle seguenti zone climatiche in funzione dei gradi-giorno, indipendentemente dalla ubicazione geografica:

Zona A - Comuni che presentano un numero di gradi-giorno non superiore a 600;

Zona B - Comuni che presentano un numero di gradi-giorno maggiore di 600 e non superiore a 900;

Zona C - Comuni che presentano un numero di gradi-giorno maggiore di 900 e non superiore a 1400;

Zona D - Comuni che presentano un numero di gradi-giorno maggiore di 1400 e non superiore a 2100;

Zona E - Comuni che presentano un numero di gradi-giorno maggiore di 2100 e non superiore a 3000;

Zona F - Comuni che presentano un numero di gradi-giorno maggiore di 3000.

I valori di trasmittanza termica U_f sotto riportati sono i risultati di calcolo eseguiti dall'Istituto ITC-CNR di San Giuliano Milanese, secondo la normativa UNI EN ISO 10077-2

The thermal performance values U_f hereunder reported are calculation results from the Institute ITC-CNR of San Giuliano Milanese, in accordance with the norm UNI EN ISO 10077-2

Nella porzione di tubolarità delimitata dalle barrette del taglio termico si assume:

- Il valore pari a 0,90 per l'emissività dell'alluminio verniciato
- Il valore pari a 0,30 per l'emissività dell'alluminio non verniciato

The equivalent thermal conductivity of the cavity between aluminium and polyamid bars is:

- 0,90 If the aluminium is painted
- 0,30 If the aluminium is mill finish

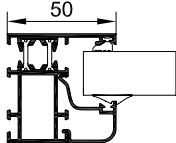
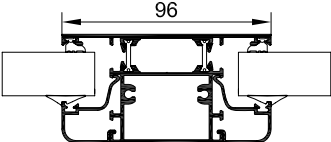
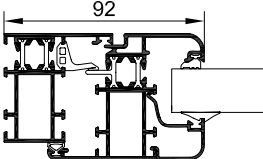
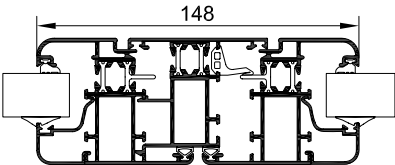
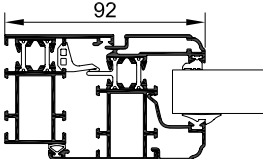
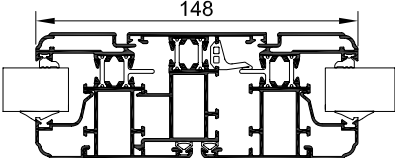
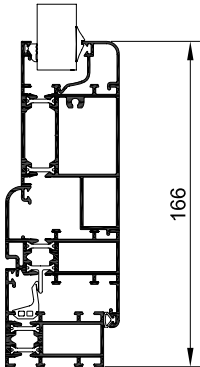
CERTIFICATI		CERTIFICATES			
Sistema System	Sezioni Cross section	Profilati Section	Risultati calcolo Calculus values		Laboratorio Certificato N°. Laboratory Certificate Nr°.
			$U_f = W/m^2 \cdot K$		
			$\epsilon = 0.9$	$\epsilon = 0.3$	
R 50 ^{TT} SYSTEM		R50C44	3.69	3.59	ITC N°4707/RP/08
R 50 ^{TT} SYSTEM		R50C69	3.38	3.13	ITC N°4708/RP/08
R 50 ^{TT} SYSTEM		R50C44 R50C42	3.73	3.67	ITC N°4681/RP/08
R 50 ^{TT} SYSTEM		R50C42 R50C43 R50C42	3.78	3.67	ITC N°4709/RP/08
R 50 ^{TT} SYSTEM		R50C98 R50C44	3.73	3.65	ITC N°4711/RP/08
R 50 ^{TT} SYSTEM		R50C98 R50C43 R50C98	3.70	3.62	ITC N°4712/RP/08
R 50 ^{TT} SYSTEM		R50C54 R50C42 R50C44	3.56	3.43	ITC N°4710/RP/08

Una corretta posa in opera, evita spesso il decadimento delle prestazioni ottenute in laboratorio, curare in maniera appropriata la posa valorizza tutto il processo produttivo dalla progettazione all'installazione.

Fare una pulizia periodica con prodotti neutri riduce notevolmente i rischi di corrosione ed allunga sicuramente la vita dell'infisso. Per una corretta installazione, manutenzione e pulizia dei serramenti, Vi raccomandiamo di consultare le prescrizioni riportate sulle seguenti note tecniche UNCSAAL:

UX42 - "Guida alla posa in opera dei serramenti"

UX10 - " La pulizia delle superfici di serramenti e facciate continue"

A correct installation, often avoids the decay of the performances obtained in the laboratory. Taking appropriate care of the installation increases the value of the whole production process from the planning to the installation.

Cleaning periodically with neutral products reduces remarkably the corrosion risk and extends surely the life of the frame.

For a correct installation, maintenance and cleaning of the sections, we recommend you refer to the prescriptions quoted in the following technical notes of UNCSAAL UX42 and UX10



LEGHE IN ALLUMINIO DA BONIFICA - PROFILATI ESTRUSI
HEAT-TREATABLE ALUMINIUM ALLOYS - EXTRUSION SECTIONS

Leghe / Alloys		6060 UNI EN 573-3				
Composizione chimica normale / Normal chemical compos		Mg 0,4 Si 0,4 Fe 0,2				
Stato / State		0	T1	T5	T6	
Caratteristiche meccaniche <i>Mechanical Characteristics</i>	Carico di rottura a trazione <i>Ultimate tensite stress</i>	R _m N/mm ²	140 Max	120	185	205
	Carico al limite di snervamento <i>Yield point</i>	R _p N/mm ²	80 Max	50	145	165
	Allungamento <i>Elongation</i>	A %	20	16	11	10
Caratteristiche fisiche <i>Physical Characteristics</i>	Peso specifico <i>Specific weight</i>	Kg/dm ³	2,70			
	Conducibilità termica a 20°C <i>Heat conductivity at 20°C</i>	W/ (cm °K)	≈ 2,09		≈ 1,75	
	Resistività elettrica a 20°C <i>Electrical resistivity at 20°C</i>	μΩ ·cm	≈ 3,14		≈ 3,25	
	Coef. di dilatazione termica lineare da 20° a 200°C <i>Linear thermal expansion coefficient from 20° to 200° C</i>		24 ·10 ⁻⁶ K ⁻¹			

Gli accessori originali Sapa, specifici del sistema, sono gli unici che garantiscono nel tempo la qualità del prodotto finale

The original Sapa accessories, specifically designed for the system, are the only ones that guarantee quality of end products through time

AVVERTENZA
NOTE

Per gli articoli indicati con ^(xxx) è possibile scegliere tra diversi produttori, tali articoli sono comunque forniti da Sapa. Le combinazioni possibili sono le seguenti:

(ABP) - Prodotte da ALUTEC, BMP e PRODUCTA.
(AB) - Prodotte da ALUTEC e BMP.
(AP) - Prodotte da ALUTEC e PRODUCTA.
(BP) - Prodotte da BMP e PRODUCTA.

For the articles indicating ^(xxx) there is the possibility to choose between different manufacturers although the goods will be supplied by Sapa. Here following the different combinations:

*(ABP) - Produced by ALUTEC, BMP and PRODUCTA.
(AB) - Produced by ALUTEC and BMP.
(AP) - Produced by ALUTEC and PRODUCTA.
(BP) - Produced by BMP and PRODUCTA.*

Per ordinare tali prodotti, è necessario inserire al termine del codice i seguenti numeri:

To order the articles you will need to indicate following numbers at the end of the code:

01 - Per BMP

01 - For manufacturer BMP

02 - Per ALUTEC

02 - For manufacturer ALUTEC

03 - Per PRODUCTA

03 - For manufacturer PRODUCTA

Esempio: Art. G.0135.EN^(ABP) La scelta può essere fatta tra BMP (ordinando il codice G.0135.EN.01), ALUTEC (codice G.0135.EN.02) e PRODUCTA (codice G.0135.EN.03).

Example: Article G.0135.EN^(ABP) the choice may be between BMP (ordering art. G.0135.EN.01), ALUTEC (ordering art. G.0135.EN.02) and PRODUCTA (ordering art. G.0135.EN.03).

Es.2: Art. G.0135.EN^(AB) La scelta può essere fatta tra BMP (ordinando il codice G.0135.EN.01) ed ALUTEC (codice G.0135.EN.02).

Example n°2: Article G.0135.EN^(AB) the choice may be between BMP (ordering art. G.0135.EN.01) and Alutec (ordering art. G.0135.EN.02)

Il codice di alcuni accessori comprende due lettere tra parentesi (xx) ciò significa che all'atto dell'ordine occorre specificare la finitura sostituendo le xx con i numeri riportati nella seguente tabella.

In some of the accessory codes you will find 2 letters in brackets (xx), this means that when you will order these articles you will have to specify the finishing replacing the xx with the numbers listed here below:

01=grezzo	} a richiesta
02=ossidato argento	
03=ossidato bronzo	
04=elettrocolore testa di moro	
05=ossidato nero	
08=ossidato oro lucido	
24=PVD oro	
28=PVD inox satinato	
60=verniciato bianco RAL 9010	
61=verniciato avorio RAL 1013	
62=verniciato crema RAL 9001	
65=verniciato verde RAL 6005	
67=verniciato marrone RAL 8017	
69=verniciato nero RAL 9005	
71=verniciato argento RAL 9006	

01=raw	} upon request
02=anodized silver	
03=anodized bronze	
04=eletcrocolor dark brown	
05=anodized black	
08=anodized	
24=PVD gold	
28=PVD glazed steel	
60=white painted RAL 9010	
61=ivory painted RAL 1013	
62=cream painted RAL 9001	
65=green painted RAL 6005	
67=brown painted RAL 8017	
69=black painted RAL 9005	
71=silver painted RAL 9006	

Esempio:

A.4003.ZX.(xx) (Cremonese reversibile per aperture interne) se ordinata **A.4003.ZX.60** verrà fornita verniciata bianco RAL 9010, se invece viene ordinata **A.4003.ZX.69**, verrà fornita Verniciata nero RAL 9005.

For example:

A.4003.ZX.(xx) (reversible cremone bolt for internal opening) if you order **A.4003.ZX.60** you will receive it white painted RAL 9010, if instead you order **A.4003.ZX.69** you will receive it black painted RAL 9005

ACCESSORI UNIVERSALI
UNIVERSAL ACCESSORIES

ACCESSORI UNIVERSALI
UNIVERSAL ACCESSORIES

Articolo Item	Immagine Picture	Descrizione Description	Articolo Item	Immagine Picture	Descrizione Description
299.703.XX (Alutec)		Cerniera pesante per porta - 3 ali interasse 70 mm 3 wings heavy hinge for door distance between centers mm 70	299.602.XX (Alutec)		Cerniera pesante per porta - 2 ali interasse 60 mm. Heavy hinge for door door - 2 wings distance between centers 60 mm
		R50TT R62TT R72TT R72TTCE R72TT1.3 R85TT1.0			R50TT R62TT R72TT R72TTCE R72TT1.3 R85TT1.0
299.702.XX (Alutec)		Cerniera pesante per porta - 2 ali interasse 70 mm 2 wings heavy hinge for door distance between centers mm 70	299.603.XX (Alutec)		Cerniera pesante per porta - 3 ali interasse 60 mm. Heavy hinge for door door - 3 wings distance between centers mm 60
		R50TT R62TT R72TT R72TTCE R72TT1.3 R85TT1.0			R50TT R62TT R72TT R72TTCE R72TT1.3 R85TT1.0
299.007.XX (Alutec)		Spessore da 7 mm per cerniere pesanti 7 mm shims for heavy hinges	299.862.XX (Alutec)		Cerniera pesante per porta - 2 ali interasse 86 mm. Heavy hinge for door door - 2 wings distance between centers mm 86
		R50TT R62TT R72TT R72TTCE R72TT1.3 R85TT1.0			R50TT R62TT R72TT R72TTCE R72TT1.3 R85TT1.0
299.962.XX (Alutec)		Cerniera pesante per porta - 2 ali interasse 96 mm 2 wings heavy hinge for door distance between centers mm 96	299.863.XX (Alutec)		Cerniera pesante per porta - 3 ali interasse 86 mm. Asse di rotazione a 20 mm. Heavy hinge for door door - 3 wings distance between centers mm 86
		R50TT R62TT R72TT R72TTCE R72TT1.3 R85TT1.0			R50TT R62TT R72TT R72TTCE R72TT1.3 R85TT1.0
299.963.XX (Alutec)		Cerniera pesante per porta - 3 ali interasse 96 mm 3 wings heavy hinge for door distance between centers mm 96	280.068.01 (Alutec)		Albero con losanga per profili 55 a 64mm Lozenge rod for profiles from 55 to 64mm
		R50TT R62TT R72TT R72TTCE R72TT1.3 R85TT1.0			R50TT R62TT
299.008.XX (Alutec)		Spessore da 8 mm per cerniere pesanti. 8 mm shims for heavy hinges.	A.4702.ZX		Kit per maniglia porte doppia Double door handle kit
		R50TT R62TT R72TT R72TTCE R72TT1.3 R85TT1.0			R50TT R62TT R72TT R72TTCE R72TT1.3 R85TT1.0
299.017.00 (Alutec)		Kit distanziali da 17 a 26 mm per profili T.T. apertura esterna Kit spacers from mm 17 to 26 for T.B. profiles external opening			
		R50TT R62TT			

CERNIERE E CARDINI
HINGES AND PIVOTS

CERNIERE E CARDINI
HINGES AND PIVOTS

Articolo Item	Immagine Picture	Descrizione Description						
401.024.XX (Alutec)		Cerniera STOPPER portata max 100 Kg <i>Hinge STOPPER capacity max kg 100</i>						
		<table border="1"> <tr> <td>R50TT</td> <td>R62TT</td> <td>R72TT</td> </tr> <tr> <td></td> <td>R72TT1.3</td> <td>R85TT1.0</td> </tr> </table>	R50TT	R62TT	R72TT		R72TT1.3	R85TT1.0
R50TT	R62TT	R72TT						
	R72TT1.3	R85TT1.0						

Articolo Item	Immagine Picture	Descrizione Description						
501.340.XX (Alutec)		Cerniera sfilabile per 3a anta da 50 mm. <i>Slip-off 3rd leaf hinge mm 50</i>						
		<table border="1"> <tr> <td>R50TT</td> <td>R62TT</td> <td>R72TT</td> </tr> <tr> <td></td> <td>R72TT1.3</td> <td>R85TT1.0</td> </tr> </table>	R50TT	R62TT	R72TT		R72TT1.3	R85TT1.0
R50TT	R62TT	R72TT						
	R72TT1.3	R85TT1.0						

401.124.XX (Alutec)		Cerniera STOPPER 3a anta portata max 100 Kg <i>Hinge STOPPER 3rd leaf capacity max kg 100</i>						
		<table border="1"> <tr> <td>R50TT</td> <td>R62TT</td> <td>R72TT</td> </tr> <tr> <td></td> <td>R72TT1.3</td> <td>R85TT1.0</td> </tr> </table>	R50TT	R62TT	R72TT		R72TT1.3	R85TT1.0
R50TT	R62TT	R72TT						
	R72TT1.3	R85TT1.0						

501.342.XX (Alutec)		Cerniera sfilabile maggiorata con contropiastra in acciaio inox. <i>Slip-off oversized hinge with stainless steel counterplate.</i>						
		<table border="1"> <tr> <td>R50TT</td> <td>R62TT</td> <td>R72TT</td> </tr> <tr> <td></td> <td>R72TT1.3</td> <td>R85TT1.0</td> </tr> </table>	R50TT	R62TT	R72TT		R72TT1.3	R85TT1.0
R50TT	R62TT	R72TT						
	R72TT1.3	R85TT1.0						

501.013.55 (Alutec)		Rondella spessoramento cerniere sfilabili. <i>Spacing washer for slip off hinges.</i>						
		<table border="1"> <tr> <td>R50TT</td> <td>R62TT</td> <td>R72TT</td> </tr> <tr> <td></td> <td>R72TT1.3</td> <td>R85TT1.0</td> </tr> </table>	R50TT	R62TT	R72TT		R72TT1.3	R85TT1.0
R50TT	R62TT	R72TT						
	R72TT1.3	R85TT1.0						

501.349.XX (Alutec)		Cerniera sfilabile su profili complanari I.E. monoblocco a cinghia da 40 mm <i>Slip-off hinge on coplanar profile I.E. beltshutter winding system mm 40</i>						
		<table border="1"> <tr> <td>R50TT</td> <td>R62TT</td> <td>R72TT</td> </tr> <tr> <td></td> <td>R72TT1.3</td> <td>R85TT1.0</td> </tr> </table>	R50TT	R62TT	R72TT		R72TT1.3	R85TT1.0
R50TT	R62TT	R72TT						
	R72TT1.3	R85TT1.0						

401.002.XX (Alutec)		Cerniera sfilabile con contropiastra in acciaio inox. <i>Slip-off hinge with stainless steel counterplate.</i>						
		<table border="1"> <tr> <td>R50TT</td> <td>R62TT</td> <td>R72TT</td> </tr> <tr> <td></td> <td>R72TT1.3</td> <td>R85TT1.0</td> </tr> </table>	R50TT	R62TT	R72TT		R72TT1.3	R85TT1.0
R50TT	R62TT	R72TT						
	R72TT1.3	R85TT1.0						

501.370.XX (Alutec)		Cerniera a pettine a 5 ali R50 Special 5 wings hing						
		<table border="1"> <tr> <td>R50TT</td> <td>R62TT</td> <td>R72TT</td> </tr> <tr> <td></td> <td>R72TT1.3</td> <td>R85TT1.0</td> </tr> </table>	R50TT	R62TT	R72TT		R72TT1.3	R85TT1.0
R50TT	R62TT	R72TT						
	R72TT1.3	R85TT1.0						









501.240.XX (Alutec)		Cerniera sfilabile 3a anta con contropiastra in acciaio inox. <i>Slip-off hinge 3rd leaf with stainless steel counterplate.</i>						
		<table border="1"> <tr> <td>R50TT</td> <td>R62TT</td> <td>R72TT</td> </tr> <tr> <td></td> <td>R72TT1.3</td> <td>R85TT1.0</td> </tr> </table>	R50TT	R62TT	R72TT		R72TT1.3	R85TT1.0
R50TT	R62TT	R72TT						
	R72TT1.3	R85TT1.0						









501.310.XX (Alutec)		Cerniera a pettine Special hinge						
		<table border="1"> <tr> <td>R50TT</td> <td>R62TT</td> <td>R72TT</td> </tr> <tr> <td></td> <td>R72TT1.3</td> <td>R85TT1.0</td> </tr> </table>	R50TT	R62TT	R72TT		R72TT1.3	R85TT1.0
R50TT	R62TT	R72TT						
	R72TT1.3	R85TT1.0						

501.330.XX (Alutec)		Cerniera sfilabile da 50 mm. <i>Slip-off hinge mm 50</i>						
		<table border="1"> <tr> <td>R50TT</td> <td>R62TT</td> <td>R72TT</td> </tr> <tr> <td></td> <td>R72TT1.3</td> <td>R85TT1.0</td> </tr> </table>	R50TT	R62TT	R72TT		R72TT1.3	R85TT1.0
R50TT	R62TT	R72TT						
	R72TT1.3	R85TT1.0						

SQUADRETTE D'ANGOLO
CORNER JOINTS

SQUADRETTE D'ANGOLO
CORNER JOINTS

Articolo Item	Immagine Picture	Descrizione Description						
A.2919.NN		Squadretta d'allineamento in nylon su aletta. <i>Nylon alignment corner joint on fin.</i>						
		<table border="1"> <tr> <td>R50TT</td> <td>R62TT</td> <td>R72TT</td> </tr> <tr> <td>R72TTCE</td> <td>R72TT1.3</td> <td>R85TT1.0</td> </tr> </table>	R50TT	R62TT	R72TT	R72TTCE	R72TT1.3	R85TT1.0
R50TT	R62TT	R72TT						
R72TTCE	R72TT1.3	R85TT1.0						
A.2920.NN		Squadretta d'allineamento in nylon per profili complanari ed arrotondati. <i>Nylon alignment corner joint for coplanar and rounded profiles.</i>						
		<table border="1"> <tr> <td>R50TT</td> <td>R62TT</td> <td>R72TT</td> </tr> <tr> <td>R72TTCE</td> <td>R72TT1.3</td> <td>R85TT1.0</td> </tr> </table>	R50TT	R62TT	R72TT	R72TTCE	R72TT1.3	R85TT1.0
R50TT	R62TT	R72TT						
R72TTCE	R72TT1.3	R85TT1.0						
A.5624.AA		Squadretta d'allineamento a cianfrinare in alluminio per tubolarità 27x6.8 <i>Aluminium alignment corner joint for caulking for piping 27x6.8</i>						
		<table border="1"> <tr> <td>R50TT</td> <td>R62TT</td> <td>R72TT</td> </tr> <tr> <td>R72TTCE</td> <td>R72TT1.3</td> <td>R85TT1.0</td> </tr> </table>	R50TT	R62TT	R72TT	R72TTCE	R72TT1.3	R85TT1.0
R50TT	R62TT	R72TT						
R72TTCE	R72TT1.3	R85TT1.0						
A.5662.AA		Squadretta a cianfrinare per profili con tubolarità 6,7x7,5 <i>Crimped corner joint for profiles piping 6.7x7.5</i>						
		<table border="1"> <tr> <td>R50TT</td> <td>R62TT</td> <td>R72TT</td> </tr> <tr> <td>R72TTCE</td> <td>R72TT1.3</td> <td>R85TT1.0</td> </tr> </table>	R50TT	R62TT	R72TT	R72TTCE	R72TT1.3	R85TT1.0
R50TT	R62TT	R72TT						
R72TTCE	R72TT1.3	R85TT1.0						
2020 (Monticelli)		Squadretta d'allineamento aletta esterna "FUJI" <i>Alignment corner joint for external rabbet "FUJI"</i>						
		<table border="1"> <tr> <td>R50TT</td> <td>R62TT</td> <td>R72TT</td> </tr> <tr> <td>R72TTCE</td> <td>R72TT1.3</td> <td>R85TT1.0</td> </tr> </table>	R50TT	R62TT	R72TT	R72TTCE	R72TT1.3	R85TT1.0
R50TT	R62TT	R72TT						
R72TTCE	R72TT1.3	R85TT1.0						
2006 (Monticelli)		Squadretta d'allineamento profilati complanari "FUJI" <i>Alignment corner joint profiles complanarities "FUJI"</i>						
		<table border="1"> <tr> <td>R50TT</td> <td>R62TT</td> <td>R72TT</td> </tr> <tr> <td>R72TTCE</td> <td>R72TT1.3</td> <td>R85TT1.0</td> </tr> </table>	R50TT	R62TT	R72TT	R72TTCE	R72TT1.3	R85TT1.0
R50TT	R62TT	R72TT						
R72TTCE	R72TT1.3	R85TT1.0						
2013 (Monticelli)		Squadretta d'allineamento aletta interna "FUJI" <i>Alignment corner joint for internal rabbet "FUJI"</i>						
		<table border="1"> <tr> <td>R50TT</td> <td>R62TT</td> <td>R72TT</td> </tr> <tr> <td>R72TTCE</td> <td>R72TT1.3</td> <td>R85TT1.0</td> </tr> </table>	R50TT	R62TT	R72TT	R72TTCE	R72TT1.3	R85TT1.0
R50TT	R62TT	R72TT						
R72TTCE	R72TT1.3	R85TT1.0						
5033 (Monticelli)		Squadretta d'angolo interno profilato R50C104 <i>Corner joint for internal profile R50C104</i>						
		<table border="1"> <tr> <td>R50TT</td> <td>R62TT</td> <td>R72TT</td> </tr> <tr> <td></td> <td>R72TT1.3</td> <td></td> </tr> </table>	R50TT	R62TT	R72TT		R72TT1.3	
R50TT	R62TT	R72TT						
	R72TT1.3							

Articolo Item	Immagine Picture	Descrizione Description						
VILM 5x14_D8 (Monticelli)		Vite per squadrette 5033,5043,5044 <i>Screw for corner joint 5033,5043,5044</i>						
VILM 5x14_0088 (Monticelli)		Spina per squadrette 5043,5044 <i>Pinned for corner joint 5043,5044</i>						
		<table border="1"> <tr> <td>R50TT</td> <td>R62TT</td> <td>R72TT</td> </tr> <tr> <td></td> <td>R72TT1.3</td> <td>R85TT1.0</td> </tr> </table>	R50TT	R62TT	R72TT		R72TT1.3	R85TT1.0
R50TT	R62TT	R72TT						
	R72TT1.3	R85TT1.0						
A.3102.AA		Squadretta d'allineamento profilati mostra <i>Alignment corner joint profiles cornice</i>						
		<table border="1"> <tr> <td>R50TT</td> <td>R62TT</td> <td>R72TT</td> </tr> <tr> <td>R72TTCE</td> <td>R72TT1.3</td> <td>R85TT1.0</td> </tr> </table>	R50TT	R62TT	R72TT	R72TTCE	R72TT1.3	R85TT1.0
R50TT	R62TT	R72TT						
R72TTCE	R72TT1.3	R85TT1.0						
A.4411.AA		Squadretta in alluminio estruso per tubolarità 10,4x42 <i>Extruded aluminium corner joint piping 10,4x42</i>						
		<table border="1"> <tr> <td>R50TT</td> <td>R62TT</td> <td>R72TT</td> </tr> <tr> <td>R72TTCE</td> <td>R72TT1.3</td> <td>R85TT1.0</td> </tr> </table>	R50TT	R62TT	R72TT	R72TTCE	R72TT1.3	R85TT1.0
R50TT	R62TT	R72TT						
R72TTCE	R72TT1.3	R85TT1.0						
A.5429.AA		Squadretta in alluminio estruso per profili maggiorati 38.8x29.2 <i>Extruded aluminium corner joint for oversized profiles piping 38.8x29.2</i>						
		<table border="1"> <tr> <td>R50TT</td> <td>R62TT</td> <td>R72TT</td> </tr> <tr> <td></td> <td>R72TT1.3</td> <td>R85TT1.0</td> </tr> </table>	R50TT	R62TT	R72TT		R72TT1.3	R85TT1.0
R50TT	R62TT	R72TT						
	R72TT1.3	R85TT1.0						
A.5411.AA		Squadretta in alluminio estruso per tubolarità 15 x 25 <i>Extruded aluminium corner joint piping 15 x 25</i>						
		<table border="1"> <tr> <td>R50TT</td> <td>R62TT</td> <td>R72TT</td> </tr> <tr> <td>R72TTCE</td> <td>R72TT1.3</td> <td>R85TT1.0</td> </tr> </table>	R50TT	R62TT	R72TT	R72TTCE	R72TT1.3	R85TT1.0
R50TT	R62TT	R72TT						
R72TTCE	R72TT1.3	R85TT1.0						
A.5441.AA		Squadretta in alluminio estruso con inserto unificato per tubolarità 15x29,2 <i>Extruded aluminium corner joint with unified ins. piping 15x29.2</i>						
		<table border="1"> <tr> <td>R50TT</td> <td>R62TT</td> <td>R72TT</td> </tr> <tr> <td></td> <td>R72TT1.3</td> <td>R85TT1.0</td> </tr> </table>	R50TT	R62TT	R72TT		R72TT1.3	R85TT1.0
R50TT	R62TT	R72TT						
	R72TT1.3	R85TT1.0						
A.2921.AA		Squadretta esterna a cianfrinare per tubolarità 16,8x7 <i>External corner joint for crimped 16,8x7</i>						
		<table border="1"> <tr> <td>R50TT</td> <td>R62TT</td> <td>R72TT</td> </tr> <tr> <td>R72TTCE</td> <td>R72TT1.3</td> <td>R85TT1.0</td> </tr> </table>	R50TT	R62TT	R72TT	R72TTCE	R72TT1.3	R85TT1.0
R50TT	R62TT	R72TT						
R72TTCE	R72TT1.3	R85TT1.0						
A.2906.AA		Squadretta a cianfrinare per profili con tubolarità 15x29,5mm <i>Crimped corner joint for profiles piping 15x29,5mm</i>						
		<table border="1"> <tr> <td>R50TT</td> <td>R62TT</td> <td>R72TT</td> </tr> <tr> <td>R72TTCE</td> <td>R72TT1.3</td> <td>R85TT1.0</td> </tr> </table>	R50TT	R62TT	R72TT	R72TTCE	R72TT1.3	R85TT1.0
R50TT	R62TT	R72TT						
R72TTCE	R72TT1.3	R85TT1.0						

SQUADRETTE D'ANGOLO
CORNER JOINTS

ACCESSORI COMPLEMENTARI
COMPLEMENTARY ACCESSORIES

Articolo Item	Immagine Picture	Descrizione Description						
A.2915.AA		Squadretta d'angolo per profilato R50C115 (tubolarità 15x24,7) Corner joint for profile R50C115 (piping mm 15x24,7)						
		<table border="1"> <tr> <td>R50TT</td> <td>R62TT</td> <td>R72TT</td> </tr> <tr> <td></td> <td>R72TT1.3</td> <td></td> </tr> </table>	R50TT	R62TT	R72TT		R72TT1.3	
R50TT	R62TT	R72TT						
	R72TT1.3							

Articolo Item	Immagine Picture	Descrizione Description						
502.002.XX (Alutec)		Angolo stampato per fermavetro arrotondato. Moulded corner for snap-on rounded glass beading.						
		<table border="1"> <tr> <td>R50TT</td> <td>R62TT</td> <td>R72TT</td> </tr> <tr> <td></td> <td>R72TT1.3</td> <td>R85TT1.0</td> </tr> </table>	R50TT	R62TT	R72TT		R72TT1.3	R85TT1.0
R50TT	R62TT	R72TT						
	R72TT1.3	R85TT1.0						

Articolo Item	Immagine Picture	Descrizione Description						
0092 (Monticelli)		Spina in acciaio inox per squadrette Pinned stainless to corner joints						
		<table border="1"> <tr> <td>R50TT</td> <td>R62TT</td> <td>R72TT</td> </tr> <tr> <td>R72TTCE</td> <td>R72TT1.3</td> <td>R85TT1.0</td> </tr> </table>	R50TT	R62TT	R72TT	R72TTCE	R72TT1.3	R85TT1.0
R50TT	R62TT	R72TT						
R72TTCE	R72TT1.3	R85TT1.0						

Articolo Item	Immagine Picture	Descrizione Description						
R950.001		Aggancio fermavetri arrotondati. Rounded glass beading coupling.						
		<table border="1"> <tr> <td>R50TT</td> <td>R62TT</td> <td>R72TT</td> </tr> <tr> <td></td> <td>R72TT1.3</td> <td>R85TT1.0</td> </tr> </table>	R50TT	R62TT	R72TT		R72TT1.3	R85TT1.0
R50TT	R62TT	R72TT						
	R72TT1.3	R85TT1.0						

Articolo Item	Immagine Picture	Descrizione Description						
0133 (Monticelli)		Squadretta a cianfrinare, spinare e avvitare per profili con tubolarità 6,7x7,5mm Corner joint for piping, crimped and screw to profiles 6,7x7,5mm						
		<table border="1"> <tr> <td>R50TT</td> <td>R62TT</td> <td>R72TT</td> </tr> <tr> <td>R72TTCE</td> <td>R72TT1.3</td> <td>R85TT1.0</td> </tr> </table>	R50TT	R62TT	R72TT	R72TTCE	R72TT1.3	R85TT1.0
R50TT	R62TT	R72TT						
R72TTCE	R72TT1.3	R85TT1.0						

GIUNTI
JOINTS

Articolo Item	Immagine Picture	Descrizione Description						
A.3204.ZA		Cavalotto di giunzione telai-traversi. T-joint for frames and transoms						
		<table border="1"> <tr> <td>R50TT</td> <td>R62TT</td> <td>R72TT</td> </tr> <tr> <td>R72TTCE</td> <td>R72TT1.3</td> <td>R85TT1.0</td> </tr> </table>	R50TT	R62TT	R72TT	R72TTCE	R72TT1.3	R85TT1.0
R50TT	R62TT	R72TT						
R72TTCE	R72TT1.3	R85TT1.0						

Articolo Item	Immagine Picture	Descrizione Description						
5043 (Monticelli)		Squadretta in alluminio estruso a cianfrinare, spinare e avvitare per profili maggiorati 38,8x29,2mm Extruded aluminium corner joint for piping, crimped and screw to profiles 38,8x29,2mm						
		<table border="1"> <tr> <td>R50TT</td> <td>R62TT</td> <td>R72TT</td> </tr> <tr> <td></td> <td>R72TT1.3</td> <td>R85TT1.0</td> </tr> </table>	R50TT	R62TT	R72TT		R72TT1.3	R85TT1.0
R50TT	R62TT	R72TT						
	R72TT1.3	R85TT1.0						

Articolo Item	Immagine Picture	Descrizione Description						
505.267.01 (Alutec)		Giunto in alluminio estruso. Extruded aluminium joint.						
		<table border="1"> <tr> <td>R50TT</td> <td>R62TT</td> <td>R72TT</td> </tr> <tr> <td></td> <td>R72TT1.3</td> <td>R85TT1.0</td> </tr> </table>	R50TT	R62TT	R72TT		R72TT1.3	R85TT1.0
R50TT	R62TT	R72TT						
	R72TT1.3	R85TT1.0						

Articolo Item	Immagine Picture	Descrizione Description						
5034 (Monticelli)		Squadretta in alluminio estruso a cianfrinare, spinare e avvitare con inserto unificato per tubolarità 15x29,2mm Extruded aluminium corner joint for piping, crimped and screw to profiles 15x29,2mm						
		<table border="1"> <tr> <td>R50TT</td> <td>R62TT</td> <td>R72TT</td> </tr> <tr> <td></td> <td>R72TT1.3</td> <td>R85TT1.0</td> </tr> </table>	R50TT	R62TT	R72TT		R72TT1.3	R85TT1.0
R50TT	R62TT	R72TT						
	R72TT1.3	R85TT1.0						

MANIGLIE, CREMONESI, ETC.
HANDLES, CREMONE BOLTS, ETC.

MANIGLIE, CREMONESI, ETC.
HANDLES, CREMONE BOLTS, ETC.

Articolo Item	Immagine Picture	Descrizione Description
------------------	---------------------	----------------------------

Articolo Item	Immagine Picture	Descrizione Description
------------------	---------------------	----------------------------

A.4003.ZX.(xx)		Cremonese reversibile per aperture interne interasse 84-100 <i>Reversible cremone bolt for internal opening distance between centers 84-100</i>	R50TT	R62TT	R72TT
				R72TT1.3	R85TT1.0

A.4011.ZX.(xx)		Cremonese reversibile con chiave per anta ribalta interasse 84-100 <i>Reversible cremone bolt with key for tilt and turn distance between centers 84-100</i>	R50TT	R62TT	R72TT
				R72TT1.3	R85TT1.0

A.4004.ZX.(xx)		Cremonese reversibile per anta ribalta interasse 84-100 <i>Reversible cremone bolt for tilt and turn distance between centers 84-100</i>	R50TT	R62TT	R72TT
				R72TT1.3	R85TT1.0

A.4012.ZX.(xx)		Cremonese reversibile per anta ribalta con chiave logica DX interasse 84-100 <i>Reversible cremone bolt for tilt and turn with logical key DX distance between centers 84-100</i>	R50TT	R62TT	R72TT
				R72TT1.3	R85TT1.0

A.4005.ZX.(xx)		Cremonese reversibile con chiave per apertura interna interasse 84-100 <i>Reversible cremone bolt with key for internal opening distance between centers 84-100</i>	R50TT	R62TT	R72TT
				R72TT1.3	R85TT1.0

A.4013.ZX.(xx)		Cremonese reversibile per anta ribalta con chiave logica SX interasse 84-100 <i>Reversible cremone bolt for tilt and turn with logical key SX distance between centers 84-100</i>	R50TT	R62TT	R72TT
				R72TT1.3	R85TT1.0

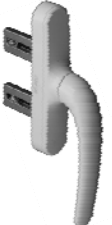
A.4006.ZX.(xx)		Cremonese reversibile per apertura esterna interasse 84-100 <i>Reversible cremone bolt for external opening distance between centers 84-100</i>	R50TT	R62TT	R72TT
				R72TT1.3	R85TT1.0

A.4014.ZX.(xx)		Cremonese reversibile con chiave per apertura esterna interasse 84-100 <i>Reversible cremone bolt with key for external opening distance between centers 84-100</i>	R50TT	R62TT	R72TT
				R72TT1.3	R85TT1.0

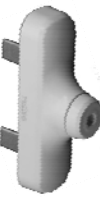
A.4008.ZX.(xx)		Cremonese reversibile aperture interne senza manico interasse 84-100 <i>Reversible cremone bolt without handle for internal opening distance between centers 84-100</i>	R50TT	R62TT	R72TT
				R72TT1.3	R85TT1.0

A.4015.ZX.(xx)		Cremonese reversibile con manico ribassato per apertura esterna interasse 84-100 <i>Reversible cremone with lowered handle bolt for external opening distance between centers 84-100</i>	R50TT	R62TT	R72TT
				R72TT1.3	R85TT1.0

A.4009.ZX.(xx)		Cremonese reversibile per anta ribalta interasse 84-100 senza manico <i>Reversible cremone bolt for tilt and turn without handle distance between centers 84-100</i>	R50TT	R62TT	R72TT

A.4701.ZX.(xx)		Maniglia martellina interasse 43 <i>Marteline handle distance between centers 43</i>	R50TT	R62TT	R72TT
				R72TT1.3	R85TT1.0

A.4010.ZN		Manico estraibile per cremone <i>Detachable handle cremone bolt</i>	R50TT	R62TT	R72TT
				R72TT1.3	R85TT1.0

MANIGLIE, CREMONESI, ETC.
HANDLES, CREMONE BOLTS, ETC.

CHIUSURE
LOCKINGS

Articolo Item	Immagine Picture	Descrizione Description	Articolo Item	Immagine Picture	Descrizione Description												
503.463.XX (Alutec)		Maniglia a tavellino VELA reversibile, per apertura esterna con battuta 8 mm, manico smontabile e meccanismo a scatto a 90°. <i>VELA flat catch, reversible, for external opening with mm 8 rabbet and removable handle and snap mechanism at 90°.</i>	A.4308.ZA		Meccanismo interno per maniglia martellina interasse 43 quadro 7 mm <i>Internal mechanism for marteline handle distance between centers 43 square 7 mm</i>												
		<table border="1"><tr><td>R50TT</td><td>R62TT</td><td>R72TT</td></tr><tr><td>R72TTCE</td><td>R72TT1.3</td><td>R85TT1.0</td></tr></table>	R50TT	R62TT	R72TT	R72TTCE	R72TT1.3	R85TT1.0			<table border="1"><tr><td>R50TT</td><td>R62TT</td><td>R72TT</td></tr><tr><td></td><td>R72TT1.3</td><td>R85TT1.0</td></tr></table>	R50TT	R62TT	R72TT		R72TT1.3	R85TT1.0
R50TT	R62TT	R72TT															
R72TTCE	R72TT1.3	R85TT1.0															
R50TT	R62TT	R72TT															
	R72TT1.3	R85TT1.0															
503.464.XX (Alutec)		Maniglia a tavellino VELA reversibile, per apertura esterna con battuta 8 mm, manico smontabile e meccanismo a scatto a 90°. Manico in zama <i>VELA flat catch, reversible, for external opening with mm 8 rabbet and removable handle and snap mechanism at 90°. Zamak handle</i>	A.4309.ZA		Meccanismo interno per anta ribalta e maniglia martellina interasse 43 quadro 7 mm <i>Internal mechanism for tilt ant turn and marteline handle distance between centers 43 square 7 mm</i>												
		<table border="1"><tr><td>R50TT</td><td>R62TT</td><td>R72TT</td></tr><tr><td>R72TTCE</td><td>R72TT1.3</td><td>R85TT1.0</td></tr></table>	R50TT	R62TT	R72TT	R72TTCE	R72TT1.3	R85TT1.0			<table border="1"><tr><td>R50TT</td><td>R62TT</td><td>R72TT</td></tr><tr><td></td><td>R72TT1.3</td><td>R85TT1.0</td></tr></table>	R50TT	R62TT	R72TT		R72TT1.3	R85TT1.0
R50TT	R62TT	R72TT															
R72TTCE	R72TT1.3	R85TT1.0															
R50TT	R62TT	R72TT															
	R72TT1.3	R85TT1.0															
503.963.XX (Alutec)		Maniglia a tavellino linea "600" per sporgere e bilico. <i>"600" flatcatch handle for projecting and pivoting windows.</i>	403.801.55 (Alutec)		Manovra per puntali 404.145.05 - 404.141.55 in abbinamento all'asta 900221 <i>Deadlatch for terminals 404.145.05 - 404.141.55 to pair with rod 900221</i>												
		<table border="1"><tr><td>R50TT</td><td>R62TT</td><td>R72TT</td></tr><tr><td></td><td>R72TT1.3</td><td>R85TT1.0</td></tr></table>	R50TT	R62TT	R72TT		R72TT1.3	R85TT1.0			<table border="1"><tr><td>R50TT</td><td>R62TT</td><td>R72TT</td></tr><tr><td></td><td>R72TT1.3</td><td>R85TT1.0</td></tr></table>	R50TT	R62TT	R72TT		R72TT1.3	R85TT1.0
R50TT	R62TT	R72TT															
	R72TT1.3	R85TT1.0															
R50TT	R62TT	R72TT															
	R72TT1.3	R85TT1.0															
280.002.XX (Alutec)		Cricchetto universale UNIV. carter, gancio e riscontro in alluminio, particolari di scorrimento in nylon caricato <i>Universal spring latch aluminium carter, hook and striker, nylon sliding parts</i>	403.806.05 (Alutec)		Manovra a leva con blocchetto di collegamento per puntali 404.145.05 - 404.141.55 <i>Lever deadlatch with junction block for terminals 404.145.05 - 404.141.55</i>												
		<table border="1"><tr><td>R50TT</td><td>R62TT</td><td>R72TT</td></tr><tr><td>R72TTCE</td><td>R72TT1.3</td><td>R85TT1.0</td></tr></table>	R50TT	R62TT	R72TT	R72TTCE	R72TT1.3	R85TT1.0			<table border="1"><tr><td>R50TT</td><td>R62TT</td><td>R72TT</td></tr><tr><td></td><td>R72TT1.3</td><td>R85TT1.0</td></tr></table>	R50TT	R62TT	R72TT		R72TT1.3	R85TT1.0
R50TT	R62TT	R72TT															
R72TTCE	R72TT1.3	R85TT1.0															
R50TT	R62TT	R72TT															
	R72TT1.3	R85TT1.0															
503.641.XX (Alutec)		Chiusura a cricchetto regolabile per vasistas <i>Adjustable spring catch for hopper windows</i>	403.852.05 (Alutec)		Asta di prolunga <i>Extension rod</i> L = 1000 mm												
		<table border="1"><tr><td>R50TT</td><td>R62TT</td><td>R72TT</td></tr><tr><td></td><td>R72TT1.3</td><td>R85TT1.0</td></tr></table>	R50TT	R62TT	R72TT		R72TT1.3	R85TT1.0			<table border="1"><tr><td>R50TT</td><td>R62TT</td><td>R72TT</td></tr><tr><td></td><td>R72TT1.3</td><td>R85TT1.0</td></tr></table>	R50TT	R62TT	R72TT		R72TT1.3	R85TT1.0
R50TT	R62TT	R72TT															
	R72TT1.3	R85TT1.0															
R50TT	R62TT	R72TT															
	R72TT1.3	R85TT1.0															
503.642.XX (Alutec)		Chiusura a cricchetto per vasistas. <i>Spring latch locking for hopper windows.</i>	503.094.55 (Alutec)		Chiusura a scatto per anta semifissa. <i>Snap release locking for semi-fixed leaf.</i>												
		<table border="1"><tr><td>R50TT</td><td>R62TT</td><td>R72TT</td></tr><tr><td></td><td>R72TT1.3</td><td>R85TT1.0</td></tr></table>	R50TT	R62TT	R72TT		R72TT1.3	R85TT1.0			<table border="1"><tr><td>R50TT</td><td>R62TT</td><td>R72TT</td></tr><tr><td></td><td>R72TT1.3</td><td>R85TT1.0</td></tr></table>	R50TT	R62TT	R72TT		R72TT1.3	R85TT1.0
R50TT	R62TT	R72TT															
	R72TT1.3	R85TT1.0															
R50TT	R62TT	R72TT															
	R72TT1.3	R85TT1.0															
			503.160.69 (Alutec)		Serratura con cilindro in zama con perno in acciaio inox. <i>Locking with zamak cylinder with stainless steel pivot.</i>												
					<table border="1"><tr><td>R50TT</td><td>R62TT</td><td>R72TT</td></tr><tr><td></td><td>R72TT1.3</td><td>R85TT1.0</td></tr></table>	R50TT	R62TT	R72TT		R72TT1.3	R85TT1.0						
R50TT	R62TT	R72TT															
	R72TT1.3	R85TT1.0															

INNESTI - PUNTALI - RICONTRI
COUPLINGS - TERMINALS - STRIKERS

INNESTI - PUNTALI - RICONTRI
COUPLINGS - TERMINALS - STRIKERS

Articolo Item	Immagine Picture	Descrizione Description
------------------	---------------------	----------------------------

Articolo Item	Immagine Picture	Descrizione Description
------------------	---------------------	----------------------------

A.3501.TA		Coppia innesti cremonese apertura interna su profilo 900221 <i>Pair of couplings internal opening for profile 900221</i>				
		<table border="1"> <tr> <td>R50TT</td> <td>R62TT</td> <td>R72TT</td> </tr> <tr> <td></td> <td>R72TT1.3</td> <td>R85TT1.0</td> </tr> </table>	R50TT	R62TT	R72TT	
R50TT	R62TT	R72TT				
	R72TT1.3	R85TT1.0				

504.081.55 (Alutec)		Riscontro in nylon con rullino per puntali <i>Nylon striker with roller for terminals</i>				
		<table border="1"> <tr> <td>R50TT</td> <td>R62TT</td> <td>R72TT</td> </tr> <tr> <td></td> <td>R72TT1.3</td> <td>R85TT1.0</td> </tr> </table>	R50TT	R62TT	R72TT	
R50TT	R62TT	R72TT				
	R72TT1.3	R85TT1.0				

A.4016.IA A.4017.IA A.4018.IA A.4019.IA		Perno di collegamento per aperture esterne lunghezza: <i>Pin for external opening lenght:</i>										
		<table border="1"> <tr> <td>17 mm</td> <td></td> <td></td> </tr> <tr> <td>22 mm</td> <td></td> <td></td> </tr> <tr> <td>25 mm</td> <td></td> <td></td> </tr> <tr> <td>30 mm</td> <td></td> <td></td> </tr> </table>	17 mm			22 mm			25 mm			30 mm
17 mm												
22 mm												
25 mm												
30 mm												
		<table border="1"> <tr> <td>R50TT</td> <td>R62TT</td> <td>R72TT</td> </tr> <tr> <td></td> <td>R72TT1.3</td> <td>R85TT1.0</td> </tr> </table>	R50TT	R62TT	R72TT		R72TT1.3	R85TT1.0				
R50TT	R62TT	R72TT										
	R72TT1.3	R85TT1.0										

504.091.05 (Alutec)		Riscontro regolabile per puntali: <i>Adjustable striker for terminals:</i>				
		<table border="1"> <tr> <td>R50TT</td> <td>R62TT</td> <td>R72TT</td> </tr> <tr> <td></td> <td>R72TT1.3</td> <td>R85TT1.0</td> </tr> </table>	R50TT	R62TT	R72TT	
R50TT	R62TT	R72TT				
	R72TT1.3	R85TT1.0				

404.100.02 (Alutec)		Nottolino di chiusura supplementare su astina <i>Rivetting additional locking point on the rod</i>				
		<table border="1"> <tr> <td>R50TT</td> <td>R62TT</td> <td>R72TT</td> </tr> <tr> <td></td> <td>R72TT1.3</td> <td>R85TT1.0</td> </tr> </table>	R50TT	R62TT	R72TT	
R50TT	R62TT	R72TT				
	R72TT1.3	R85TT1.0				

504.103.01 (Alutec)		Riscontro per terza chiusura su innesti cremonese: 404.110.55 <i>Striker for 3rd locking on couplings: 404.110.55</i>				
		<table border="1"> <tr> <td>R50TT</td> <td>R62TT</td> <td>R72TT</td> </tr> <tr> <td></td> <td>R72TT1.3</td> <td>R85TT1.0</td> </tr> </table>	R50TT	R62TT	R72TT	
R50TT	R62TT	R72TT				
	R72TT1.3	R85TT1.0				

404.101.02 (Alutec)		Incontro supplementare su telaio <i>Additional locking point on the sash</i>				
		<table border="1"> <tr> <td>R50TT</td> <td>R62TT</td> <td>R72TT</td> </tr> <tr> <td></td> <td>R72TT1.3</td> <td>R85TT1.0</td> </tr> </table>	R50TT	R62TT	R72TT	
R50TT	R62TT	R72TT				
	R72TT1.3	R85TT1.0				

504.120.01 (Alutec)		Riscontro con rullino in acciaio inox per chiusure supplementari, apertura interna e anta ribalta. <i>Striker with stainless steel roller for additional lockings internal opening and tilt and turn</i>				
		<table border="1"> <tr> <td>R50TT</td> <td>R62TT</td> <td>R72TT</td> </tr> <tr> <td></td> <td>R72TT1.3</td> <td>R85TT1.0</td> </tr> </table>	R50TT	R62TT	R72TT	
R50TT	R62TT	R72TT				
	R72TT1.3	R85TT1.0				

404.141.55 (Alutec)		Coppia puntali in nylon su profilo 900221 <i>Pair of terminals on profile 900221</i>				
		<table border="1"> <tr> <td>R50TT</td> <td>R62TT</td> <td>R72TT</td> </tr> <tr> <td></td> <td>R72TT1.3</td> <td>R85TT1.0</td> </tr> </table>	R50TT	R62TT	R72TT	
R50TT	R62TT	R72TT				
	R72TT1.3	R85TT1.0				

504.206.05 (Alutec)		Incontro di chiusura supplementare lato cerniere. <i>U-Bolt for additional locking hinge side</i>				
		<table border="1"> <tr> <td>R50TT</td> <td>R62TT</td> <td>R72TT</td> </tr> <tr> <td></td> <td>R72TT1.3</td> <td>R85TT1.0</td> </tr> </table>	R50TT	R62TT	R72TT	
R50TT	R62TT	R72TT				
	R72TT1.3	R85TT1.0				

404.121.05 (Alutec)		Kit chiusura supplementare per apertura interna ed esterna. <i>Additional lock kit for internal and external opening.</i>				
		<table border="1"> <tr> <td>R50TT</td> <td>R62TT</td> <td>R72TT</td> </tr> <tr> <td></td> <td>R72TT1.3</td> <td>R85TT1.0</td> </tr> </table>	R50TT	R62TT	R72TT	
R50TT	R62TT	R72TT				
	R72TT1.3	R85TT1.0				

INCONTRI SERRATURA
LOCK JUNCTION

Articolo Item	Immagine Picture	Descrizione Description
------------------	---------------------	----------------------------

404.145.05 (Alutec)		Coppia puntali in zama, su profilo 900221 <i>Pair of zamak terminals on profile 900221</i>				
		<table border="1"> <tr> <td>R50TT</td> <td>R62TT</td> <td>R72TT</td> </tr> <tr> <td></td> <td>R72TT1.3</td> <td>R85TT1.0</td> </tr> </table>	R50TT	R62TT	R72TT	
R50TT	R62TT	R72TT				
	R72TT1.3	R85TT1.0				

417.250.55 (Alutec)		Incontro serratura. <i>Lock junction.</i>				
		<table border="1"> <tr> <td>R50TT</td> <td>R62TT</td> <td>R72TT</td> </tr> <tr> <td></td> <td>R72TT1.3</td> <td>R85TT1.0</td> </tr> </table>	R50TT	R62TT	R72TT	
R50TT	R62TT	R72TT				
	R72TT1.3	R85TT1.0				

COMPASSI
ARMS

COMPASSI
ARMS

Articolo Item	Immagine Picture	Descrizione Description
------------------	---------------------	----------------------------

Articolo Item	Immagine Picture	Descrizione Description
------------------	---------------------	----------------------------

A.1812.VV



Braccio limitatore di apertura DX
Opening limiter arm DX

R50TT	R62TT	R72TT
	R72TT1.3	R85TT1.0

406.499.05
(Alutec)



Gruppo articolazione per sporgere rinforzato completo di bracci, portata max kg. 90
Kit for stiffened projecting windows with arms capacity max 90 kg.

L = mm 300

R50TT	R62TT	R72TT
	R72TT1.3	R85TT1.0

A.1813.VV



Braccio limitatore di apertura SX
Opening limiter arm SX

R50TT	R62TT	R72TT
	R72TT1.3	R85TT1.0

406.500.05
(Alutec)



Coppia aste a sporgere portata max 50 kg.
Pair of projecting rods capacity max 50 kg.

L = mm 500

R50TT	R62TT	R72TT
	R72TT1.3	R85TT1.0

A.3905.IA



Coppia bracci ammortizzati sganciabili in acciaio inox per vasistas
Pair of detachable amortized stainless steel arms for hopper windows

250 ≤ H_{ANTA} ≤ 500 mm

R50TT	R62TT	R72TT
	R72TT1.3	R85TT1.0

A.3906.IA



Coppia bracci ammortizzati sganciabili in acciaio inox per vasistas
Pair of detachable amortized stainless steel arms for hopper windows

350 ≤ H_{ANTA} ≤ 1600 mm

R50TT	R62TT	R72TT
	R72TT1.3	R85TT1.0

A.3907.IA



Coppia bracci ammortizzati sganciabili in acciaio inox per vasistas
Pair of detachable amortized stainless steel arms for hopper windows

1000 ≤ H_{ANTA} ≤ 2000 mm

R50TT	R62TT	R72TT
	R72TT1.3	R85TT1.0

506.300.05
(Alutec)



Gruppo articolazione per sporgere comprensivo di coppie di rinforzo in acciaio inox portata max. kg. 75
Kit for projecting windows inclusive of stiffened stainless steel torques capacity max 75 kg.

R50TT	R62TT	R72TT
	R72TT1.3	R85TT1.0

406.300.05
(Alutec)



Coppia aste a sporgere portata max 50 kg.
Pair of projecting rods capacity max 50 kg.

L = mm 300

R50TT	R62TT	R72TT
	R72TT1.3	R85TT1.0

ANTA RIBALTA **R**balta 150
TILT AND TURN

R50TT	R62TT	R72TT
	R72TT1.3	R85TT1.0

ANTA RIBALTA **R**balta 150
TILT AND TURN

R50TT	R62TT	R72TT
	R72TT1.3	R85TT1.0

Articolo Item	Immagine Picture	Descrizione Description
------------------	---------------------	----------------------------

A.1800.VV		<p>Kit base anta ribalta "Rbalta 150" composto da:</p> <ul style="list-style-type: none"> • Rinvio d'angolo in zama con perno di chiusura integrale • Riscontro per chiusura su rinvio d'angolo • innesto cremonese personalizzato • Meccanismo anti falsa manovra • Puntale inferiore dx • Puntale inferiore sx • Perno di chiusura per puntale inferiore • Riscontro per chiusura su puntale • Riscontro orizzontale per puntale inferiore
		<p>"Rbalta 150" tilt and turn basic kit, consisting of :</p> <ul style="list-style-type: none"> • with zama corner locking pin integral • lock striker to corner drive • custom couplings cremonese • lock movement • lower terminals dx • lower terminals sx • lock pin for lower terminals • lock striker on terminals • orizontal striker on lower terminals

Articolo Item	Immagine Picture	Descrizione Description
------------------	---------------------	----------------------------

A.1805.VX.(xx)		<p>Kit completo anta ribalta "Rbalta 150" con braccio medio, composto da:</p> <ul style="list-style-type: none"> • Kit base - A.1800.VV • Kit cerniere verniciate - A.1801.VX • Cremonese anta ribalta - A.4004.ZX • Braccio medio (L=550 / 1700) - A.1802.VV <p>"Rbalta 150" tilt and turn complete with standard arm:</p> <ul style="list-style-type: none"> • Kit base - A.1800.VV • Kit hinge painted - A.1801.VX • Tilt and turn cremone - A.4004.ZX • Standard arm (L=550/1700) A.1802.VV
		<p>Kit completo anta ribalta "Rbalta 150" con braccio corto, composto da:</p> <ul style="list-style-type: none"> • Kit base - A.1800.VV • Kit cerniere verniciate - A.1801.VX • Cremonese anta ribalta - A.4004.ZX • Braccio corto (L=350 / 549) - A.1803.VV <p>"Rbalta 150" tilt and turn complete with short arm:</p> <ul style="list-style-type: none"> • Kit base - A.1800.VV • Kit hinge painted - A.1801.VX • Tilt and turn cremone - A.4004.ZX • Short arm (L=350/549) A.1803.VV

Accessori supplementari
Additional accessories

R50TT	R62TT	R72TT
	R72TT1.3	R85TT1.0

Articolo Item	Descrizione Description
------------------	----------------------------

A.1801.VX.(xx)	Kit cerniere verniciate portata 150 Kg Hinges kit painted loaded 150 Kg
A.1802.VV	Braccio medio (L=550 / 1700mm) Standard arm (L=550 / 1700mm)
A.1803.VV	Braccio corto (L=350 / 549mm) Short arm (L=350 / 549mm)
A.1804.VV	Braccio supplementare (L>1200mm) Supplementary arm (L>1200mm)
A.1807.VV	Kit chiusura supplementare su asta Supplementary closure point
A.1808.VV	Rinvio d'angolo supplementare inferiore e superiore Supplementary corner drive upper and lower







Accessori supplementari
Additional accessories

R50TT	R62TT	R72TT
	R72TT1.3	R85TT1.0

Articolo Item	Descrizione Description
------------------	----------------------------

A.1809.VX.(xx)	Kit cerniere anta affiancata Hinge kit to side leaf
A.1810.VV	Kit paletti anta semifissa Kit of latches for semi-fixed leaf
A.1811.VV	Kit paletti anta semifissa a manovra e leva Kit of latches lever bolt for semi-fixed leaf
A.1812.VV	Braccio limitatore di apertura DX Opening limitator arm DX
A.1813.VV	Braccio limitatore di apertura SX Opening limitator arm SX
A.4004.ZX.(xx)	Cremonese anta ribalta Tilt and turn cremone





MONOBLOCCO
SHUTTER WINDING SYSTEM

Articolo Item	Immagine Picture	Descrizione Description						
402.200.55 (Alutec)		Angolare assiemaggio cassonetto in nylon su profilo 900297 <i>Nylon angle for shutter box assembling on profile 900297</i>						
402.201.55 (Alutec)		- Nero - Black - Bianco - White						
		<table border="1"> <tr> <td>R50TT</td> <td>R62TT</td> <td>R72TT</td> </tr> <tr> <td></td> <td>R72TT1.3</td> <td></td> </tr> </table>	R50TT	R62TT	R72TT		R72TT1.3	
R50TT	R62TT	R72TT						
	R72TT1.3							
410.485.55 (Alutec)		Distanziale per fissaggio stipite monoblocco in nylon su profilo 900274 <i>Nylon spacer for fixing door frame shutter winding system on profile 900274</i>						
		<table border="1"> <tr> <td>R50TT</td> <td>R62TT</td> <td>R72TT</td> </tr> <tr> <td></td> <td>R72TT1.3</td> <td></td> </tr> </table>	R50TT	R62TT	R72TT		R72TT1.3	
R50TT	R62TT	R72TT						
	R72TT1.3							
425.010.00 (Alutec)		Kit manovra a cinghia con avvolgitore da 5,5 m <i>Kit for belt deadlatch coiler with 5,5 m</i>						
425.011.00 (Alutec)		Kit manovra a cinghia con avvolgitore da 10 m <i>Kit for belt deadlatch coiler with 10 m</i>						
		<table border="1"> <tr> <td>R50TT</td> <td>R62TT</td> <td>R72TT</td> </tr> <tr> <td></td> <td>R72TT1.3</td> <td></td> </tr> </table>	R50TT	R62TT	R72TT		R72TT1.3	
R50TT	R62TT	R72TT						
	R72TT1.3							
425.012.00 (Alutec)		Kit manovra ad asta con arganello reversibile <i>Kit for reversible winch rod deadlatch</i>						
425.310.00 (Alutec)		Asta per arganello con snodo a 45° <i>Swinging winch rod at 45°</i>						
		<table border="1"> <tr> <td>R50TT</td> <td>R62TT</td> <td>R72TT</td> </tr> <tr> <td></td> <td>R72TT1.3</td> <td></td> </tr> </table>	R50TT	R62TT	R72TT		R72TT1.3	
R50TT	R62TT	R72TT						
	R72TT1.3							
425.112.05 (Alutec)		Coppia mensole in nylon di guida cinghia <i>Pair of nylon guide brackets</i>						
		<table border="1"> <tr> <td>R50TT</td> <td>R62TT</td> <td>R72TT</td> </tr> <tr> <td></td> <td>R72TT1.3</td> <td></td> </tr> </table>	R50TT	R62TT	R72TT		R72TT1.3	
R50TT	R62TT	R72TT						
	R72TT1.3							
425.560.55 (Alutec)		Pannello isolante cassonetto in polistirolo espanso su profili 900297 <i>Nylon bi-hole upper rabbet on profile 900297</i>						
		<table border="1"> <tr> <td>R50TT</td> <td>R62TT</td> <td>R72TT</td> </tr> <tr> <td></td> <td>R72TT1.3</td> <td></td> </tr> </table>	R50TT	R62TT	R72TT		R72TT1.3	
R50TT	R62TT	R72TT						
	R72TT1.3							
507.001.55 (Alutec)		Inviti tapparella. <i>Shutter guides.</i>						
		<table border="1"> <tr> <td>R50TT</td> <td>R62TT</td> <td>R72TT</td> </tr> <tr> <td></td> <td>R72TT1.3</td> <td></td> </tr> </table>	R50TT	R62TT	R72TT		R72TT1.3	
R50TT	R62TT	R72TT						
	R72TT1.3							



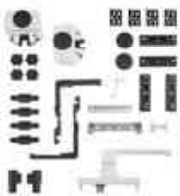
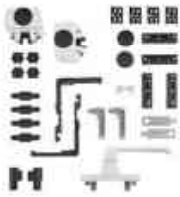

MONOBLOCCO
SHUTTER WINDING SYSTEM

Articolo Item	Immagine Picture	Descrizione Description						
510.020.00 (Alutec)		Molla tenuta cassonetto (900297) <i>Clip for shutter box fastening (Prof. 900297)</i>						
		<table border="1"> <tr> <td>R50TT</td> <td>R62TT</td> <td>R72TT</td> </tr> <tr> <td></td> <td>R72TT1.3</td> <td></td> </tr> </table>	R50TT	R62TT	R72TT		R72TT1.3	
R50TT	R62TT	R72TT						
	R72TT1.3							

BILICO
PIVOTING WINDOW

Articolo Item	Immagine Picture	Descrizione Description						
408.213.XX (Alutec)		CONFEZIONE COMPLETA Kit bilico orizzontale a chiusura multiple con cremone pressofusa <i>COMPLETE KIT Multi-point lockings horizontal pivoting window with die-casting cremone bolt</i>						
		<table border="1"> <tr> <td>R50TT</td> <td>R62TT</td> <td></td> </tr> <tr> <td></td> <td>R72TT1.3</td> <td></td> </tr> </table>	R50TT	R62TT			R72TT1.3	
R50TT	R62TT							
	R72TT1.3							
408.214.XX (Alutec)		CONFEZIONE COMPLETA Kit bilico verticale a chiusura multiple con cuscinetto reggispinta e cremone pressofusa. <i>COMPLETE KIT Multi-point locking kit for vertical pivot windows with thrust bearing with die-cast cremone bolt handle</i>						
		<table border="1"> <tr> <td>R50TT</td> <td>R62TT</td> <td></td> </tr> <tr> <td></td> <td>R72TT1.3</td> <td></td> </tr> </table>	R50TT	R62TT			R72TT1.3	
R50TT	R62TT							
	R72TT1.3							
508.025.01 (Alutec)		Distanziale fissaggio profilo inversione bilico <i>Spacer for fixing profile inversion pivoting window</i>						
		<table border="1"> <tr> <td>R50TT</td> <td>R62TT</td> <td></td> </tr> <tr> <td></td> <td>R72TT1.3</td> <td></td> </tr> </table>	R50TT	R62TT			R72TT1.3	
R50TT	R62TT							
	R72TT1.3							
508.080.XX (Alutec)		Coppia di frizioni per bilico. <i>Pair of clutches for pivoting window.</i>						
		<table border="1"> <tr> <td>R50TT</td> <td>R62TT</td> <td></td> </tr> <tr> <td></td> <td>R72TT1.3</td> <td></td> </tr> </table>	R50TT	R62TT			R72TT1.3	
R50TT	R62TT							
	R72TT1.3							
508.081.XX (Alutec)		Coppia di frizioni per bilico verticale con cuscinetto reggispinta. <i>Pair of clutches for vertical pivoting windows with thrust bearing.</i>						
		<table border="1"> <tr> <td>R50TT</td> <td>R62TT</td> <td></td> </tr> <tr> <td></td> <td>R72TT1.3</td> <td></td> </tr> </table>	R50TT	R62TT			R72TT1.3	
R50TT	R62TT							
	R72TT1.3							





TAPPI
PLUGS

Articolo Item	Immagine Picture	Descrizione Description						
A.2129.TN ^(AP)		Coppia tappi per battuta centrale su profilo R50C43. <i>Pair of plugs for central rabbet on profile R50C43.</i>						
		<table border="1"> <tr> <td>R50TT</td> <td></td> <td></td> </tr> <tr> <td></td> <td></td> <td></td> </tr> </table>	R50TT					
R50TT								
A.2143.NN ^(AP)		Tappo aggiuntivo in nylon per profilo R50C76 in abbinamento con tappo A.2129.TN <i>Nylon additional plug for profile R50C76 to combine to cod. A.2129.TN</i>						
A.2143.NB ^(AP)		Bianco RAL 9010/ White RAL 9010						
		<table border="1"> <tr> <td>R50TT</td> <td>R62TT</td> <td>R72TT</td> </tr> <tr> <td></td> <td>R72TT1.3</td> <td>R85TT1.0</td> </tr> </table>	R50TT	R62TT	R72TT		R72TT1.3	R85TT1.0
R50TT	R62TT	R72TT						
	R72TT1.3	R85TT1.0						
A.2116.TN		Tappo aggiuntivo in nylon su profilo R50C84 in abbinamento con i tappi cod. A.2129.TN <i>Nylon additional plug for section R50C84 to combine to cod. A.2129.TN</i>						
		<table border="1"> <tr> <td>R50TT</td> <td>R62TT</td> <td>R72TT</td> </tr> <tr> <td></td> <td>R72TT1.3</td> <td>R85TT1.0</td> </tr> </table>	R50TT	R62TT	R72TT		R72TT1.3	R85TT1.0
R50TT	R62TT	R72TT						
	R72TT1.3	R85TT1.0						
A.2130.TN ^(AP)		Coppia tappi per battuta centrale per apertura esterna su profilo R50C58. <i>Pair of plugs for central rabbet for external opening on profile R50C58.</i>						
		<table border="1"> <tr> <td>R50TT</td> <td></td> <td></td> </tr> <tr> <td></td> <td></td> <td></td> </tr> </table>	R50TT					
R50TT								

SCARICHI ACQUA
WATER DRAINAGES

Articolo Item	Immagine Picture	Descrizione Description						
509.270.55 (Alutec)		Valvola scarico acqua in nylon. <i>Nylon water drainage valve.</i>						
		<table border="1"> <tr> <td>R50TT</td> <td>R62TT</td> <td>R72TT</td> </tr> <tr> <td>R72TTCE</td> <td>R72TT1.3</td> <td>R85TT1.0</td> </tr> </table>	R50TT	R62TT	R72TT	R72TTCE	R72TT1.3	R85TT1.0
R50TT	R62TT	R72TT						
R72TTCE	R72TT1.3	R85TT1.0						
509.260.55 (Alutec)		Paratempesta in nylon. <i>Water drain cover of nylon.</i>						
509.260.60 (Alutec)		- nero - black - bianco - white						
		<table border="1"> <tr> <td>R50TT</td> <td>R62TT</td> <td>R72TT</td> </tr> <tr> <td>R72TTCE</td> <td>R72TT1.3</td> <td>R85TT1.0</td> </tr> </table>	R50TT	R62TT	R72TT	R72TTCE	R72TT1.3	R85TT1.0
R50TT	R62TT	R72TT						
R72TTCE	R72TT1.3	R85TT1.0						
509.261.55 (Alutec)		Paratempesta in nylon. <i>Water drain cover of nylon.</i>						
509.261.60 (Alutec)		- nero - black - bianco - white						
		<table border="1"> <tr> <td>R50TT</td> <td>R62TT</td> <td>R72TT</td> </tr> <tr> <td>R72TTCE</td> <td>R72TT1.3</td> <td>R85TT1.0</td> </tr> </table>	R50TT	R62TT	R72TT	R72TTCE	R72TT1.3	R85TT1.0
R50TT	R62TT	R72TT						
R72TTCE	R72TT1.3	R85TT1.0						
509.264.55 (Alutec)		Paratempesta in nylon. <i>Water drain cover of nylon.</i>						
509.265.55 (Alutec)		- nero - black - bianco - white						
		<table border="1"> <tr> <td>R50TT</td> <td>R62TT</td> <td>R72TT</td> </tr> <tr> <td>R72TTCE</td> <td>R72TT1.3</td> <td>R85TT1.0</td> </tr> </table>	R50TT	R62TT	R72TT	R72TTCE	R72TT1.3	R85TT1.0
R50TT	R62TT	R72TT						
R72TTCE	R72TT1.3	R85TT1.0						

SPESSORAMENTO VETRI
SHIM FOR GLASSES

Articolo Item	Immagine Picture	Descrizione Description						
507.704.55		Tassello spessoramento vetri da: <i>Shim for glasses:</i>						
507.705.55		S = mm 4 marrone - brown						
507.706.55		S = mm 5 nero - black						
507.707.55		S = mm 6 grigio - grey						
507.708.55		S = mm 7 rosso - red						
507.709.55		S = mm 8 verde - green						
		<table border="1"> <tr> <td>R50TT</td> <td>R62TT</td> <td></td> </tr> <tr> <td></td> <td></td> <td></td> </tr> </table>	R50TT	R62TT				
R50TT	R62TT							
		<table border="1"> <tr> <td>R50TT</td> <td>R62TT</td> <td></td> </tr> <tr> <td></td> <td></td> <td></td> </tr> </table>	R50TT	R62TT				
R50TT	R62TT							

ATTACCHI ALLA MURATURA
WALL FASTENERS

ATTACCHI ALLA MURATURA
WALL FASTENERS

Articolo <i>Item</i>	Immagine <i>Picture</i>	Descrizione <i>Description</i>						
410.100.00 (Alutec)		Molla in acciaio zincato per coprifilo angolare <i>Galvanized steel spring for angular coverwire</i>						
		<table border="1"> <tr> <td>R50TT</td> <td>R62TT</td> <td>R72TT</td> </tr> <tr> <td></td> <td>R72TT1.3</td> <td>R85TT1.0</td> </tr> </table>	R50TT	R62TT	R72TT		R72TT1.3	R85TT1.0
R50TT	R62TT	R72TT						
	R72TT1.3	R85TT1.0						

Articolo <i>Item</i>	Immagine <i>Picture</i>	Descrizione <i>Description</i>						
510.490.55 (Alutec)		Tappo rettangolare copriforo Ø 12 mm in polietilene <i>Rectangular coverhole plug Ø mm 12 made of polyethylene</i>						
510.490.60 (Alutec)		- colore nero - <i>black color</i> - colore bianco - <i>white color</i>						
		<table border="1"> <tr> <td>R50TT</td> <td>R62TT</td> <td>R72TT</td> </tr> <tr> <td></td> <td>R72TT1.3</td> <td>R85TT1.0</td> </tr> </table>	R50TT	R62TT	R72TT		R72TT1.3	R85TT1.0
R50TT	R62TT	R72TT						
	R72TT1.3	R85TT1.0						

410.330.55 (Alutec)		Clip ad infilare per profili angolari. <i>Insert clip for angular profiles.</i>						
		<table border="1"> <tr> <td>R50TT</td> <td>R62TT</td> <td>R72TT</td> </tr> <tr> <td></td> <td>R72TT1.3</td> <td>R85TT1.0</td> </tr> </table>	R50TT	R62TT	R72TT		R72TT1.3	R85TT1.0
R50TT	R62TT	R72TT						
	R72TT1.3	R85TT1.0						

510.481.55 (Alutec)		Distanziale per fissaggio profili 900318 e 900319 <i>Fixing 900318 and 900319</i>						
		<table border="1"> <tr> <td>R50TT</td> <td>R62TT</td> <td>R72TT</td> </tr> <tr> <td>R72TTCE</td> <td>R72TT1.3</td> <td></td> </tr> </table>	R50TT	R62TT	R72TT	R72TTCE	R72TT1.3	
R50TT	R62TT	R72TT						
R72TTCE	R72TT1.3							

410.405.01 (Alutec)		Basetta unificata per regolo mobile in zama pressofusa. <i>Unified plate for adjustable block made of die-casting zamak.</i>						
		<table border="1"> <tr> <td>R50TT</td> <td>R62TT</td> <td>R72TT</td> </tr> <tr> <td></td> <td>R72TT1.3</td> <td>R85TT1.0</td> </tr> </table>	R50TT	R62TT	R72TT		R72TT1.3	R85TT1.0
R50TT	R62TT	R72TT						
	R72TT1.3	R85TT1.0						









510.480.01 (Alutec)		Fissaggio a muro laterale in alluminio estruso. <i>Extruded aluminium lateral wall fastener.</i>						
		<table border="1"> <tr> <td>R50TT</td> <td>R62TT</td> <td>R72TT</td> </tr> <tr> <td></td> <td>R72TT1.3</td> <td>R85TT1.0</td> </tr> </table>	R50TT	R62TT	R72TT		R72TT1.3	R85TT1.0
R50TT	R62TT	R72TT						
	R72TT1.3	R85TT1.0						





510.491.55 (Alutec)		Tappo rotondo copriforo Ø 12 mm in polietilene. <i>Circular coverhole plug Ø mm 12 made of polyethylene.</i>						
		<table border="1"> <tr> <td>R50TT</td> <td>R62TT</td> <td>R72TT</td> </tr> <tr> <td></td> <td>R72TT1.3</td> <td>R85TT1.0</td> </tr> </table>	R50TT	R62TT	R72TT		R72TT1.3	R85TT1.0
R50TT	R62TT	R72TT						
	R72TT1.3	R85TT1.0						

510.415.01 (Alutec)		Regolo mobile. <i>Adjustable block.</i>						
510.420.01 (Alutec)		L = mm 15						
510.430.01 (Alutec)		L = mm 20						
510.445.01 (Alutec)		L = mm 30						
510.460.01 (Alutec)		L = mm 45						
		L = mm 60						
		<table border="1"> <tr> <td>R50TT</td> <td>R62TT</td> <td>R72TT</td> </tr> <tr> <td></td> <td>R72TT1.3</td> <td>R85TT1.0</td> </tr> </table>	R50TT	R62TT	R72TT		R72TT1.3	R85TT1.0
R50TT	R62TT	R72TT						
	R72TT1.3	R85TT1.0						

ATTREZZATURE
TOOLS







ATTREZZATURE
TOOLS



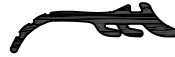





Articolo Item	Immagine Picture	Descrizione Description						
581.021.00 (Alutec)		Attezzo per posizionamento contropiastra cerniere pesanti e cardini <i>Tool for positioning counterplate for heavy hinges and</i>						
		<table border="1"> <tr> <td>R50TT</td> <td>R62TT</td> <td>R72TT</td> </tr> <tr> <td></td> <td>R72TT1.3</td> <td>R85TT1.0</td> </tr> </table>	R50TT	R62TT	R72TT		R72TT1.3	R85TT1.0
R50TT	R62TT	R72TT						
	R72TT1.3	R85TT1.0						
581.023.00 (Alutec)		Boccola per foratura con impugnatura <i>Drilling bushing with handgrip</i>						
		<table border="1"> <tr> <td>R50TT</td> <td>R62TT</td> <td>R72TT</td> </tr> <tr> <td></td> <td>R72TT1.3</td> <td>R85TT1.0</td> </tr> </table>	R50TT	R62TT	R72TT		R72TT1.3	R85TT1.0
R50TT	R62TT	R72TT						
	R72TT1.3	R85TT1.0						
581.024.00 (Alutec)		Maschera piazzamento slitta rientro anta <i>Leaf retracting slide positioning template</i>						
		<table border="1"> <tr> <td>R50TT</td> <td>R62TT</td> <td>R72TT</td> </tr> <tr> <td></td> <td>R72TT1.3</td> <td>R85TT1.0</td> </tr> </table>	R50TT	R62TT	R72TT		R72TT1.3	R85TT1.0
R50TT	R62TT	R72TT						
	R72TT1.3	R85TT1.0						
581.025.00 (Alutec)		Morsetto di piazzamento guide scorrevoli <i>Sliding guides positioning clamp</i>						
		<table border="1"> <tr> <td>R50TT</td> <td>R62TT</td> <td>R72TT</td> </tr> <tr> <td></td> <td>R72TT1.3</td> <td>R85TT1.0</td> </tr> </table>	R50TT	R62TT	R72TT		R72TT1.3	R85TT1.0
R50TT	R62TT	R72TT						
	R72TT1.3	R85TT1.0						
581.026.00 (Alutec)		Maschera di foratura piazzamento carrelli <i>Rollers positioning drilling template</i>						
		<table border="1"> <tr> <td>R50TT</td> <td>R62TT</td> <td>R72TT</td> </tr> <tr> <td></td> <td>R72TT1.3</td> <td>R85TT1.0</td> </tr> </table>	R50TT	R62TT	R72TT		R72TT1.3	R85TT1.0
R50TT	R62TT	R72TT						
	R72TT1.3	R85TT1.0						
581.030.00 (Alutec)		Dima foratura per cerniere pesanti per montante ridotto interasse 60 mm <i>Drilling template for heavy hinges for small stile distance between centers mm 60</i>						
		<table border="1"> <tr> <td>R50TT</td> <td>R62TT</td> <td>R72TT</td> </tr> <tr> <td></td> <td>R72TT1.3</td> <td>R85TT1.0</td> </tr> </table>	R50TT	R62TT	R72TT		R72TT1.3	R85TT1.0
R50TT	R62TT	R72TT						
	R72TT1.3	R85TT1.0						
581.033.00 (Alutec)		Dima universale per tavellino. <i>Universal template for flat catch.</i>						
		<table border="1"> <tr> <td>R50TT</td> <td>R62TT</td> <td>R72TT</td> </tr> <tr> <td></td> <td>R72TT1.3</td> <td>R85TT1.0</td> </tr> </table>	R50TT	R62TT	R72TT		R72TT1.3	R85TT1.0
R50TT	R62TT	R72TT						
	R72TT1.3	R85TT1.0						
581.034.00 (Alutec)		Punzonatrice lavorazione astine <i>Punching machine for rods processing</i>						
		<table border="1"> <tr> <td>R50TT</td> <td>R62TT</td> <td>R72TT</td> </tr> <tr> <td></td> <td>R72TT1.3</td> <td>R85TT1.0</td> </tr> </table>	R50TT	R62TT	R72TT		R72TT1.3	R85TT1.0
R50TT	R62TT	R72TT						
	R72TT1.3	R85TT1.0						

Articolo Item	Immagine Picture	Descrizione Description						
581.041.00 (Alutec)		Dima foratura per cerniere ad elevata portata <i>Drilling template for heavy hinges</i>						
		<table border="1"> <tr> <td>R50TT</td> <td>R62TT</td> <td>R72TT</td> </tr> <tr> <td></td> <td>R72TT1.3</td> <td>R85TT1.0</td> </tr> </table>	R50TT	R62TT	R72TT		R72TT1.3	R85TT1.0
R50TT	R62TT	R72TT						
	R72TT1.3	R85TT1.0						
581.171.00 (Alutec)		Cesoia taglia guarnizioni in metallo UNIV. <i>Metal shear for weatherstrips cutting</i>						
		<table border="1"> <tr> <td>R50TT</td> <td>R62TT</td> <td>R72TT</td> </tr> <tr> <td>R72TTCE</td> <td>R72TT1.3</td> <td>R85TT1.0</td> </tr> </table>	R50TT	R62TT	R72TT	R72TTCE	R72TT1.3	R85TT1.0
R50TT	R62TT	R72TT						
R72TTCE	R72TT1.3	R85TT1.0						
M.2001.00		Cianfrinatrice manuale <i>Manual crimping tool</i>						
		<table border="1"> <tr> <td>R50TT</td> <td>R62TT</td> <td>R72TT</td> </tr> <tr> <td>R72TTCE</td> <td>R72TT1.3</td> <td>R85TT1.0</td> </tr> </table>	R50TT	R62TT	R72TT	R72TTCE	R72TT1.3	R85TT1.0
R50TT	R62TT	R72TT						
R72TTCE	R72TT1.3	R85TT1.0						
U.9801.VV		Chiave esagonale doppia da 4-5-6 UNIV. <i>Double hexagonal wrench of 4-5-6</i>						
		<table border="1"> <tr> <td>R50TT</td> <td>R62TT</td> <td>R72TT</td> </tr> <tr> <td>R72TTCE</td> <td>R72TT1.3</td> <td>R85TT1.0</td> </tr> </table>	R50TT	R62TT	R72TT	R72TTCE	R72TT1.3	R85TT1.0
R50TT	R62TT	R72TT						
R72TTCE	R72TT1.3	R85TT1.0						
U.9802.VV		Chiave esagonale doppia da 2.5-3 UNIV. <i>Double hexagonal wrench of 2.5-3</i>						
		<table border="1"> <tr> <td>R50TT</td> <td>R62TT</td> <td>R72TT</td> </tr> <tr> <td>R72TTCE</td> <td>R72TT1.3</td> <td>R85TT1.0</td> </tr> </table>	R50TT	R62TT	R72TT	R72TTCE	R72TT1.3	R85TT1.0
R50TT	R62TT	R72TT						
R72TTCE	R72TT1.3	R85TT1.0						

GUARNIZIONI
WEATHERSTRIPS

GUARNIZIONI
WEATHERSTRIPS

Articolo Item	Immagine Picture	Descrizione Description						
G.0119.EN		Guarnizione di battuta per bilico <i>Pivoting weatherstrip of rabbet</i> E.P.D.M. <table border="1"><tr><td>R50TT</td><td>R62TT</td><td></td></tr><tr><td></td><td>R72TT1.3</td><td></td></tr></table>	R50TT	R62TT			R72TT1.3	
R50TT	R62TT							
	R72TT1.3							
G.0123.EN		Guarnizione da 4-6 mm su f.vetro <i>mm 4-6 glass support weatherstrip</i> E.P.D.M. <table border="1"><tr><td>R50TT</td><td>R62TT</td><td>R72TT</td></tr><tr><td>R72TTCE</td><td>R72TT1.3</td><td>R85TT1.0</td></tr></table>	R50TT	R62TT	R72TT	R72TTCE	R72TT1.3	R85TT1.0
R50TT	R62TT	R72TT						
R72TTCE	R72TT1.3	R85TT1.0						
G.0124.EN		Guarnizione su fermavetro da 2,5-3,5 mm <i>mm 2,5-3,5 glass support weatherstrip</i> E.P.D.M. <table border="1"><tr><td>R50TT</td><td>R62TT</td><td>R72TT</td></tr><tr><td>R72TTCE</td><td>R72TT1.3</td><td>R85TT1.0</td></tr></table>	R50TT	R62TT	R72TT	R72TTCE	R72TT1.3	R85TT1.0
R50TT	R62TT	R72TT						
R72TTCE	R72TT1.3	R85TT1.0						
G.0126.EN ^(ABP)		Guarnizione di battuta <i>Weatherstrip of rabbet</i> EN = E.P.D.M.						
G.0138.RN ^(ABP)		RN = PVC coestruso <i>Coextruded P.V.C.</i>						
G.0155.TN ^(BP)		TN = Termoplastica <i>T.P.R.</i>						
G.0156.FN ^(BP)		FN = E.P.D.M. coestruso <i>Coextruded E.P.D.M.</i> <table border="1"><tr><td>R50TT</td><td>R62TT</td><td>R72TT</td></tr><tr><td></td><td>R72TT1.3</td><td>R85TT1.0</td></tr></table>	R50TT	R62TT	R72TT		R72TT1.3	R85TT1.0
R50TT	R62TT	R72TT						
	R72TT1.3	R85TT1.0						
G.0127.EN ^(ABP)		Guarnizione su fermavetro spessore 2 mm <i>Weatherstrip on glazing bead shim 2 mm</i> E.P.D.M. <table border="1"><tr><td>R50TT</td><td>R62TT</td><td>R72TT</td></tr><tr><td>R72TTCE</td><td>R72TT1.3</td><td>R85TT1.0</td></tr></table>	R50TT	R62TT	R72TT	R72TTCE	R72TT1.3	R85TT1.0
R50TT	R62TT	R72TT						
R72TTCE	R72TT1.3	R85TT1.0						
G.0128.EN ^(ABP)		Guarnizione su fermavetro spessore 3 mm <i>Weatherstrip on glazing bead shim 3 mm</i> E.P.D.M. <table border="1"><tr><td>R50TT</td><td>R62TT</td><td>R72TT</td></tr><tr><td>R72TTCE</td><td>R72TT1.3</td><td>R85TT1.0</td></tr></table>	R50TT	R62TT	R72TT	R72TTCE	R72TT1.3	R85TT1.0
R50TT	R62TT	R72TT						
R72TTCE	R72TT1.3	R85TT1.0						
G.0129.EN ^(ABP)		Guarnizione su fermavetro spessore 6 mm <i>Weatherstrip on glazing bead shim 6 mm</i> E.P.D.M. <table border="1"><tr><td>R50TT</td><td>R62TT</td><td>R72TT</td></tr><tr><td>R72TTCE</td><td>R72TT1.3</td><td>R85TT1.0</td></tr></table>	R50TT	R62TT	R72TT	R72TTCE	R72TT1.3	R85TT1.0
R50TT	R62TT	R72TT						
R72TTCE	R72TT1.3	R85TT1.0						
G.0131.EN ^(ABP)		Guarnizione di battuta ad inserimento a scatto <i>Released insertion weatherstrip of rabbet</i> E.P.D.M. <table border="1"><tr><td>R50TT</td><td>R62TT</td><td>R72TT</td></tr><tr><td></td><td>R72TT1.3</td><td>R85TT1.0</td></tr></table>	R50TT	R62TT	R72TT		R72TT1.3	R85TT1.0
R50TT	R62TT	R72TT						
	R72TT1.3	R85TT1.0						

Articolo Item	Immagine Picture	Descrizione Description						
G.0134.EN ^(ABP)		Guarnizione esterna vetro <i>External weatherstrips on glass</i> E.P.D.M. <table border="1"><tr><td>R50TT</td><td>R62TT</td><td>R72TT</td></tr><tr><td>R72TTCE</td><td>R72TT1.3</td><td>R85TT1.0</td></tr></table>	R50TT	R62TT	R72TT	R72TTCE	R72TT1.3	R85TT1.0
R50TT	R62TT	R72TT						
R72TTCE	R72TT1.3	R85TT1.0						
G.0135.EN ^(ABP)		Guarnizione di precamera. <i>Central weatherstrip.</i> E.P.D.M. <table border="1"><tr><td>R50TT</td><td></td><td>R72TT</td></tr><tr><td>R72TTCE</td><td>R72TT1.3</td><td></td></tr></table>	R50TT		R72TT	R72TTCE	R72TT1.3	
R50TT		R72TT						
R72TTCE	R72TT1.3							
G.0139.RN ^(ABP)		Guarnizione appoggio vetri 1.5 mm <i>Weatherstrip on glass support mm 1,5</i> PVC coestruso <i>Coextruded P.V.C.</i> <table border="1"><tr><td>R50TT</td><td>R62TT</td><td>R72TT</td></tr><tr><td>R72TTCE</td><td>R72TT1.3</td><td>R85TT1.0</td></tr></table>	R50TT	R62TT	R72TT	R72TTCE	R72TT1.3	R85TT1.0
R50TT	R62TT	R72TT						
R72TTCE	R72TT1.3	R85TT1.0						
G.0140.RN ^(ABP)		Guarnizione appoggio vetri da 3 mm <i>mm 3 glass support weatherstrip</i> PVC coestruso <i>Coextruded P.V.C.</i> <table border="1"><tr><td>R50TT</td><td>R62TT</td><td>R72TT</td></tr><tr><td>R72TTCE</td><td>R72TT1.3</td><td>R85TT1.0</td></tr></table>	R50TT	R62TT	R72TT	R72TTCE	R72TT1.3	R85TT1.0
R50TT	R62TT	R72TT						
R72TTCE	R72TT1.3	R85TT1.0						
G.0149.EN ^(BP)		Guarnizione su fermavetro spessore 4 mm <i>Weatherstrip on glazing bead shim 4 mm</i> E.P.D.M. <table border="1"><tr><td>R50TT</td><td>R62TT</td><td>R72TT</td></tr><tr><td>R72TTCE</td><td>R72TT1.3</td><td>R85TT1.0</td></tr></table>	R50TT	R62TT	R72TT	R72TTCE	R72TT1.3	R85TT1.0
R50TT	R62TT	R72TT						
R72TTCE	R72TT1.3	R85TT1.0						
G.0150.EN ^(BP)		Guarnizione su fermavetro spessore 5 mm <i>Weatherstrip on glazing bead shim 5 mm</i> E.P.D.M. <table border="1"><tr><td>R50TT</td><td>R62TT</td><td>R72TT</td></tr><tr><td>R72TTCE</td><td>R72TT1.3</td><td>R85TT1.0</td></tr></table>	R50TT	R62TT	R72TT	R72TTCE	R72TT1.3	R85TT1.0
R50TT	R62TT	R72TT						
R72TTCE	R72TT1.3	R85TT1.0						
G.0152.EN		Guarnizione appoggio esterno vetri da 3 mm <i>mm 3 glass support weatherstrip</i> E.P.D.M. <table border="1"><tr><td>R50TT</td><td>R62TT</td><td>R72TT</td></tr><tr><td>R72TTCE</td><td>R72TT1.3</td><td>R85TT1.0</td></tr></table>	R50TT	R62TT	R72TT	R72TTCE	R72TT1.3	R85TT1.0
R50TT	R62TT	R72TT						
R72TTCE	R72TT1.3	R85TT1.0						
G.0168.EN		Guarnizione isolamento termico telaio-muro <i>Weatherstrip thermal insulation frame-wall</i> E.P.D.M. <table border="1"><tr><td>R50TT</td><td>R62TT</td><td>R72TT</td></tr><tr><td>R72TTCE</td><td>R72TT1.3</td><td>R85TT1.0</td></tr></table>	R50TT	R62TT	R72TT	R72TTCE	R72TT1.3	R85TT1.0
R50TT	R62TT	R72TT						
R72TTCE	R72TT1.3	R85TT1.0						
G.0314.RN ^(AP)		Guarnizione di tenuta inferiore porte <i>Lower door seal</i> P.V.C. coestruso <i>Coextruded P.V.C.</i> <table border="1"><tr><td>R50TT</td><td>R62TT</td><td>R72TT</td></tr><tr><td>R72TTCE</td><td>R72TT1.3</td><td>R85TT1.0</td></tr></table>	R50TT	R62TT	R72TT	R72TTCE	R72TT1.3	R85TT1.0
R50TT	R62TT	R72TT						
R72TTCE	R72TT1.3	R85TT1.0						

GUARNIZIONI
WEATHERSTRIPS

ANGOLI STAMPATI IN EPDM
EPDM MOULDED CORNERS

Articolo Item	Immagine Picture	Descrizione Description						
G.0316.QN		Guarnizione porta spazzolino <i>Brush holder seal</i>						
		P.V.C. rigid <i>Rigid P.V.C.</i>						
		<table border="1"> <tr> <td>R50TT</td> <td>R62TT</td> <td>R72TT</td> </tr> <tr> <td></td> <td>R72TT1.3</td> <td>R85TT1.0</td> </tr> </table>	R50TT	R62TT	R72TT		R72TT1.3	R85TT1.0
R50TT	R62TT	R72TT						
	R72TT1.3	R85TT1.0						

Articolo Item	Immagine Picture	Descrizione Description						
A.0228.EN		Angolo stampato per guarnizione G.0135.EN <i>Moulded corner for weatherstrip G.0135.EN</i>						
		EN = E.P.D.M.						
A.0228.TN ^(AP)		TN = Termoplastica <i>T.P.R.</i>						
		<table border="1"> <tr> <td>R50TT</td> <td></td> <td>R72TT</td> </tr> <tr> <td>R72TTCE</td> <td>R72TT1.3</td> <td></td> </tr> </table>	R50TT		R72TT	R72TTCE	R72TT1.3	
R50TT		R72TT						
R72TTCE	R72TT1.3							

G.0317.RN		Guarnizione per collegamento profili <i>Profile connection gasket</i>						
		P.V.C. coestruso <i>Coextruded P.V.C.</i>						
		<table border="1"> <tr> <td>R50TT</td> <td>R62TT</td> <td>R72TT</td> </tr> <tr> <td></td> <td>R72TT1.3</td> <td>R85TT1.0</td> </tr> </table>	R50TT	R62TT	R72TT		R72TT1.3	R85TT1.0
R50TT	R62TT	R72TT						
	R72TT1.3	R85TT1.0						

DIAGRAMMI PER IL DIMENSIONAMENTO STATICO DELLE ANTE STATIC WING-SIZING DIAGRAMS

I grafici di seguito riportati sono stati ottenuti con la seguente formula:
The graphs below were created using the following formula:

$$J(\text{cm}^4) = \frac{q(\text{Kg}/\text{cm}^2) \times H^4 (\text{cm}) \times A(\text{cm})}{1920 \times E(\text{Kg}/\text{cm}^2) \times f(\text{cm})} \times \left[25 \cdot 40 \times \left(\frac{A}{H} \right)^2 + 16 \times \left(\frac{A}{H} \right)^4 \right]$$

Dove:

Jx = Momento d'inerzia (cm⁴) A = Larghezza anta : 2 (cm)
q = Carico del vento (Kg/cm²) E = Modulo di elasticità (Kg/cm²)
H = Altezza anta (cm) f = Freccia (cm)

Essa è riferita al dimensionamento delle ante rispetto all'inerzia del profilato, per cui verificare sempre che il peso delle ante sia compatibile con la portata degli accessori impiegati, cerniere ecc. Inoltre verificare, sempre che la freccia dei profilati sia compatibile con il vetro impiegato.

Were:

Jx = Moment of inertia (cm⁴) A = Wing/2 width (cm)
q = Wind load (Kg/cm²) E = Coefficient of elasticity (Kg/cm²)
H = Wing height (cm) f = Camber (cm)

This refers to the size of the wings compared with the section inertia so always make sure the weight of the wings is compatible with the load of accessories hinge etc. used. Also always check that the section camber is suitable for the glass used.

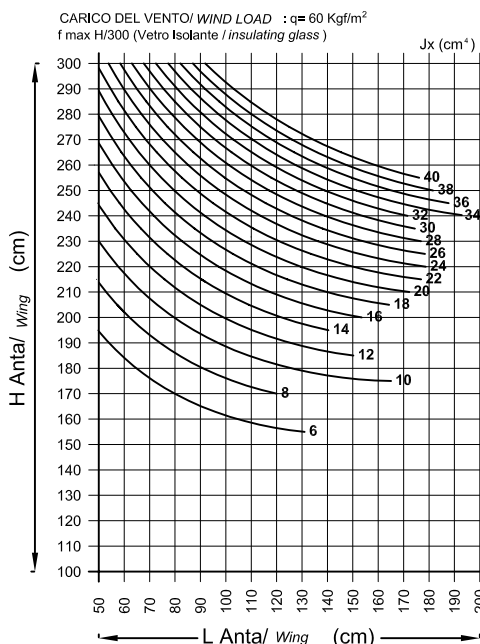
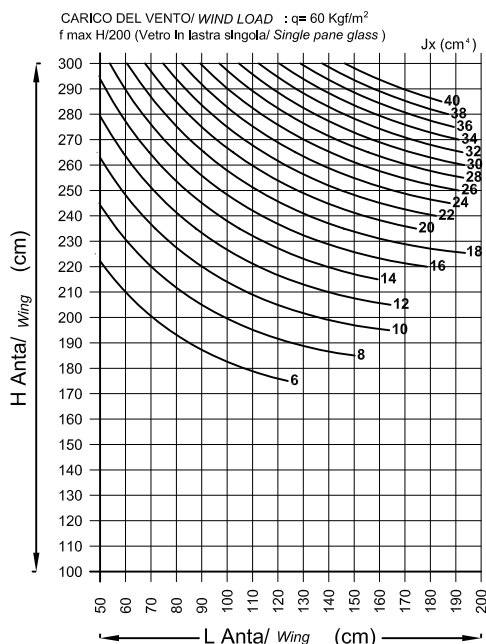
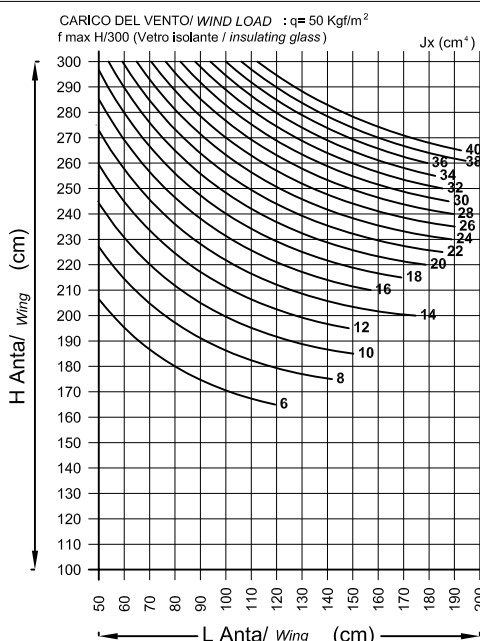
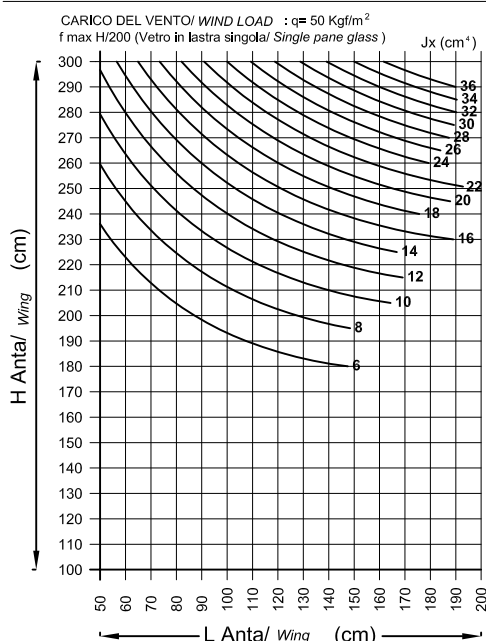
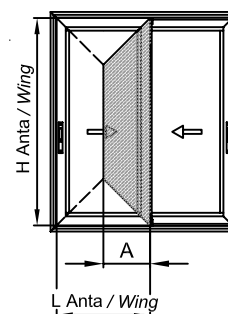
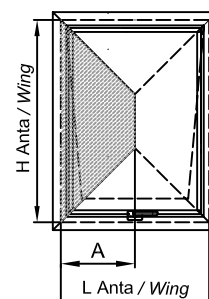
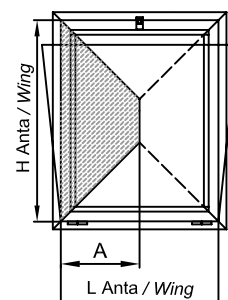
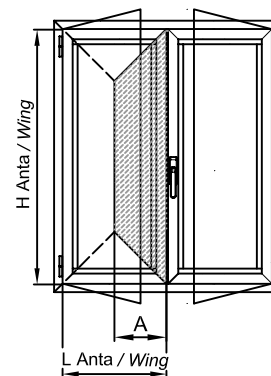
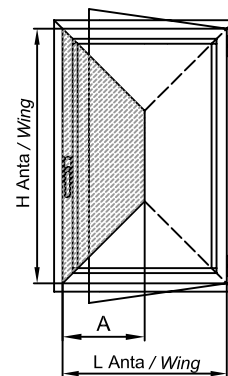

DIAGRAMMI PER IL DIMENSIONAMENTO STATICO DELLE ANTE

STATIC WING-SIZING DIAGRAMS

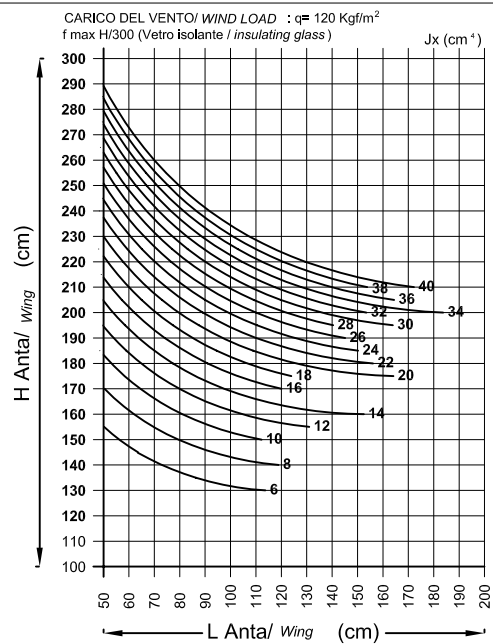
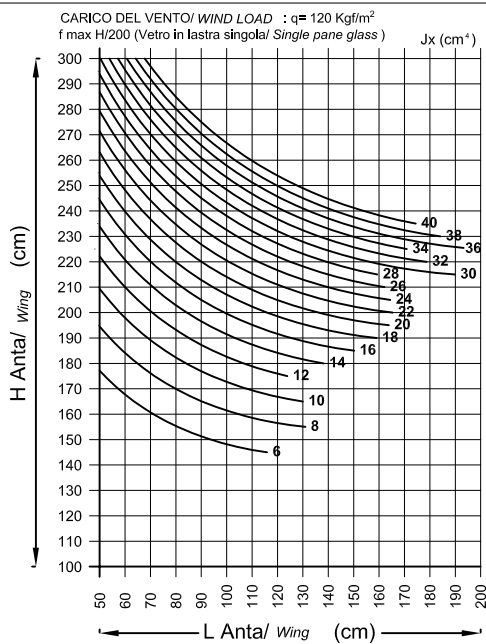
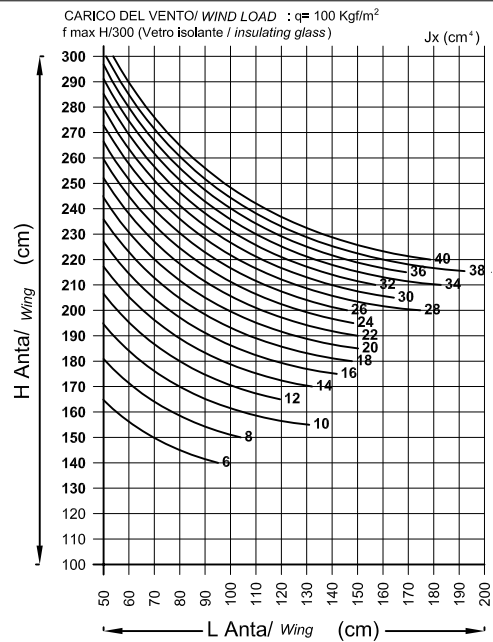
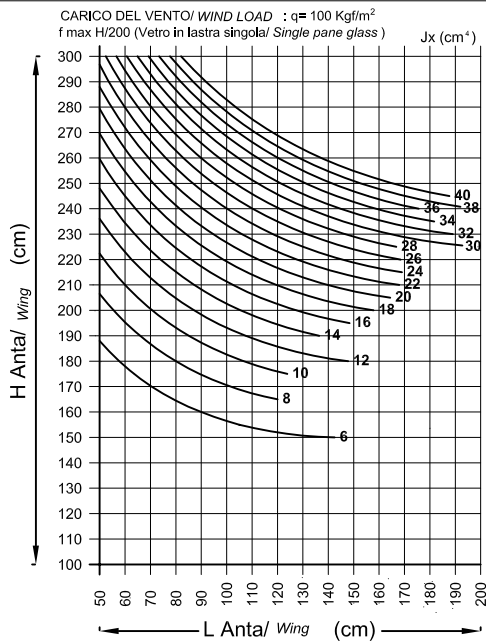
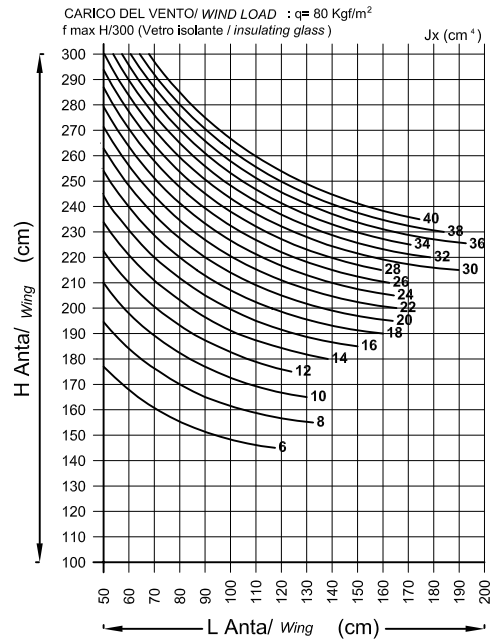
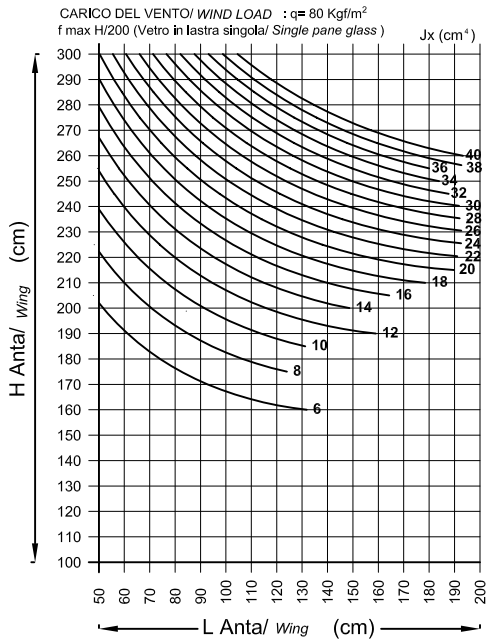

INSERIMENTO GUARNIZIONI, VETRI E FERMAVETRI WEATHERSTRIPS. GLASS AND GLASS BEADINGS INSERTION

R 50^{TT}
SYSTEM

Articolo <i>Item</i>	Guarnizioni esterne <i>External weatherstrips</i>	Sezione <i>Section</i>	Articolo <i>Item</i>	Guarnizioni interne <i>Internal weatherstrips</i>	Sezione <i>Section</i>
G.0139.RN	A = 1,5 mm		G.0127.EN	D = 2 mm	
G.0134.EN	B = 3 mm		G.0128.EN	E = 3 mm	
G.0140.RN	C = 3 mm		G.0129.EN	F = 5/6 mm	
Spessore vetri <i>Glass thickness</i>	Guarnizioni <i>Weatherstrips</i>	Dimensione fermavetri <i>Glass beading size</i>	Vetro ad infilare <i>Glass to insert</i>		
1/2 3/4 4 5 6 7	B/C + F A + F B/C + E B/C + D A + E A + D	35 mm	800902		
6/7 8/9 9 10 11 12	B/C + F A + F B/C + E B/C + D A + E A + D	30 mm	900260	900614	R950.001 900617
8/9 10/11 11 12 13 14	B/C + F A + F B/C + E B/C + D A + E A + D	28 mm	800741		
10/11 12/13 13 14 15 16	B/C + F A + F B/C + E B/C + D A + E A + D	26 mm	900259	800812	800677
14/15 15/16 17 18 18 19	B/C + F A + F B/C + E B/C + D A + E A + D	22,5 mm	900607	R950.001 600027	
14/15 16/17 17 18 19 20	B/C + F A + F B/C + E B/C + D A + E A + D	22 mm	900258		
17/18 19/20 20 21 22 23	B/C + F A + F B/C + E B/C + D A + E A + D	19 mm	800303	R950.001 800339	
18/19 20/21 21 22 23 24	B/C + F A + F B/C + E B/C + D A + E A + D	18 mm	900257	800651	R950.001 800679
19/20 21/22 22 23 24 25	B/C + F A + F B/C + E B/C + D A + E A + D	17 mm	900530		
22/23 24/25 25 26 27 28	B/C + F A + F B/C + E B/C + D A + E A + D	14 mm	900256	800307	R950.001 800313
25/26 28/27 28 29 30 31	B/C + F A + F B/C + E B/C + D A + E A + D	11 mm	800829		
26/27 28/29 29 30 31 32	B/C + F A + F B/C + E B/C + D A + E A + D	10 mm	800851		
● 27/28 ● 29/30 ● 30 ● 31 ● 32 ● 33	B/C + F A + F B/C + E B/C + D A + E A + D	9 mm	800755		
● 31/32 ● 33/34 ● 34 ● 35 ● 36 ● 37	B/C + F A + F B/C + E B/C + D A + E A + D	5 mm	800873		
● 34/35 ● 36/37 ● 37 ● 38 ● 39 ● 40	B/C + F A + F B/C + E B/C + D A + E A + D	2 mm	800874		
18/19 19/20 21 22 22 23/24	B/C + F A + F B/C + E B/C + D A + E A + D	X = 27 mm	R50C55		

















N.B.: Le combinazioni sopra indicate sono state ottenute considerando le quote teoriche. Si consiglia sempre di verificare le tolleranze per applicare vetri, fermavetri e guarnizioni ottimali.

● Spessore pannelli /

Panel thickness

The above combinations were obtained considering the theoretic heights. It is always best to check tolerances to apply correct glass, glass beadings and weatherstrips.

POSIZIONAMENTO ACCESSORIO FERMAVETRO ARROTONDATO
ROUNDED GLASSES BEADING ACCESSORY POSITIONING

Sezione Fermavetri Glass Beading Section		Dimensione Size
F	G	
		30 mm
900614	900617	
		30 mm
800681	800682	
		26 mm
800677	800678	
		22,5 mm
900607	600027	
		19 mm
800303	800339	
		18 mm
800679	800680	
		14 mm
800307	800313	
		14 mm
800661	800662	

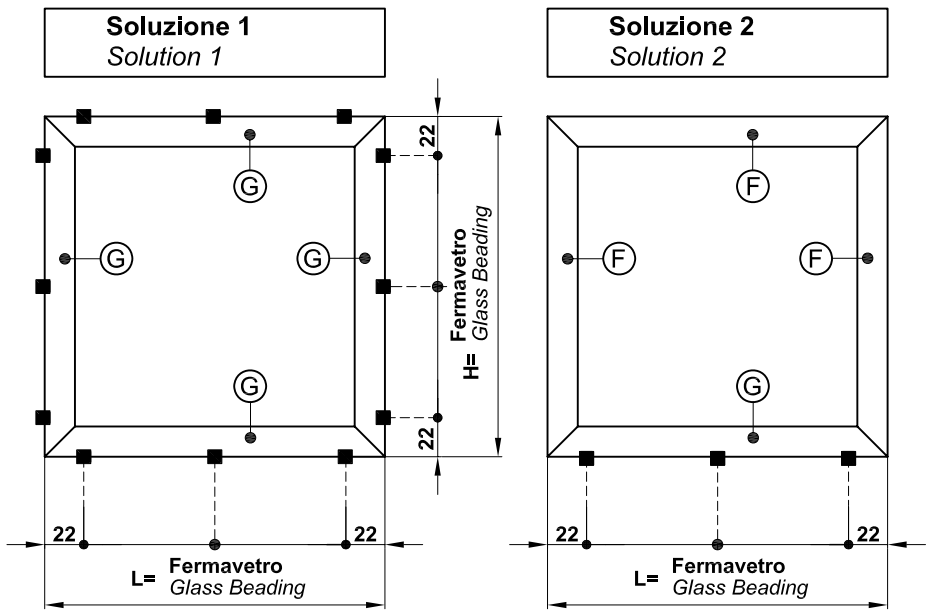



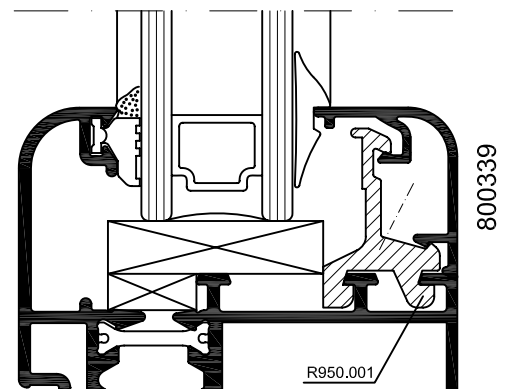
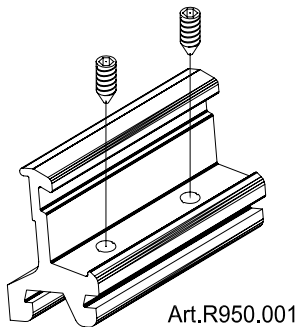



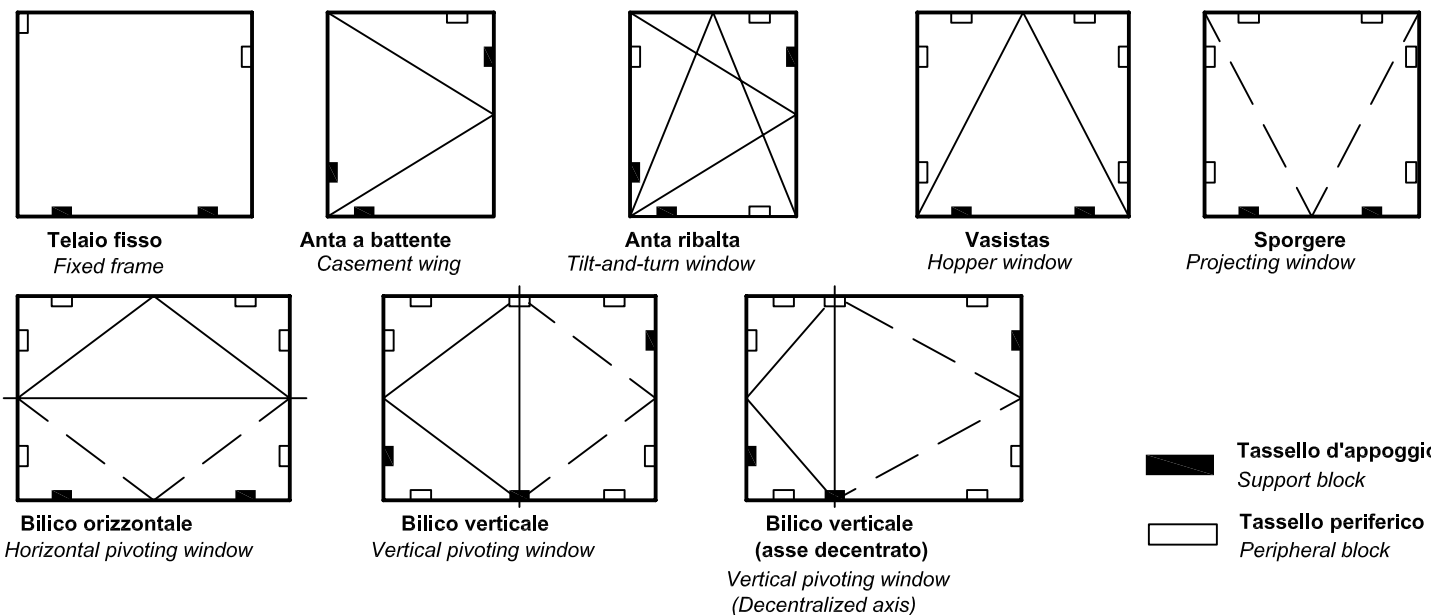









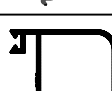
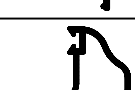
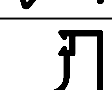

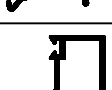

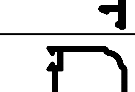

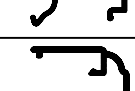
- F** = Fermavetro arr. a scatto
Radiused glass beading snap
- G** = Fermavetro arr. con accessorio R950.001
Radiused glass beading with accessorire R950.001
- = Art. R950.001
Per L/H ≤ 1000mm n°3pz
Per L/H < 1000mm ≤ 1500mm n°4pz
Per L/H > 1500mm n°5pz

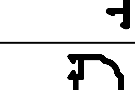

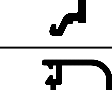
SPESSORAMENTO VETRI
GLASS SHIM

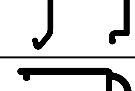
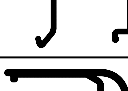

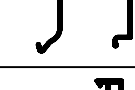
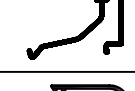
Profilato Section	Sezione Cross section	Peso Weight Kg/m	Perlm. Perim. mm	Sup. in vista Expose surface m /m ²	Profilato Section	Sezione Cross section	Peso Weight Kg/m	Perlm. Perim. mm	Sup. in vista Expose surface m /m ²
600027		0,181	115	0,042	800829		0,253	167	0,030
800303		0,271	173	0,041	800851		0,231	109	0,035
800307		0,256	169	0,040	800873		0,186	87	0,029
800313		0,145	93	0,040	800874		0,183	71	0,026
800339		0,170	108	0,044	800902		0,322	203	0,056
800651		0,251	161	0,033	900256		0,273	183	0,036
800661		0,259	167	0,032	900257		0,275	177	0,040
800662		0,140	90	0,031	900258		0,278	178	0,044
800677		0,273	173	0,044	900259		0,286	180	0,048
800678		0,184	117	0,044	900260		0,288	182	0,052
800679		0,265	169	0,036	900530		0,276	114	0,039
800680		0,154	99	0,036	900607		0,271	175	0,042
800681		0,281	178	0,048	900614		0,278	180	0,050
800682		0,197	125	0,048	900617		0,219	129	0,052
800741		0,289	183	0,050					
800755		0,262	167	0,032					
800812		0,275	174	0,040					

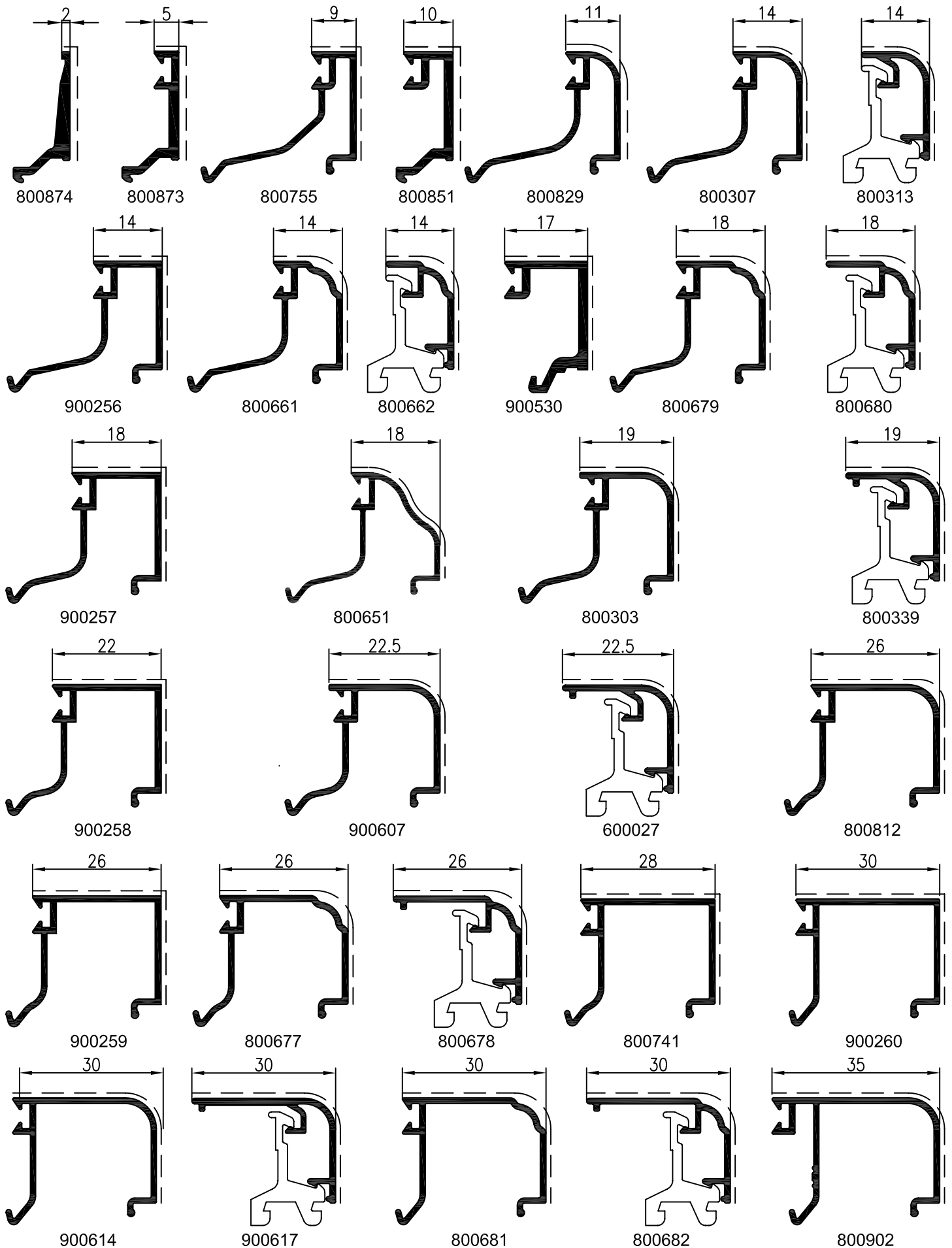









ELENCO PROFILATI
LIST OF SECTIONS

Profilato Section	Comp.ne Composition	Sezione Cross section	Peso Weight Kg/m	Perimetro Perimeter mm	Superficie in vista Exposed surface m ² /m	Jx cm ⁴	Wx cm ³	Jy cm ⁴	Wy cm ³
R50C37 R50D37	800612 A.0318.LN A.0318.LN 800610		1,618	336	0,196	27,02	5,73	27,84	5,89
R50C38 R50D38	800617 A.0318.LN A.0318.LN 800591		2,396	612	0,283	83,19	15,59	42,01	8,42
R50C39 R50D39	800617 A.0318.LN A.0318.LN 800592		2,283	550	0,258	74,30	14,56	36,02	7,50
R50C40 R50D40	800611 A.0318.LN A.0318.LN 800610		1,494	310	0,170	14,05	4,09	25,84	5,47
R50C41 R50D41	800504 A.0318.LN A.0318.LN 800585		1,232	400	0,109	14,68	5,44	8,82	2,44
R50C42 R50D42	800507 A.0317.LN A.0318.LN 800585		1,371	436	0,114	19,22	6,37	10,54	2,79
R50C43 R50D43	800587 A.0318.LN A.0318.LN 800586		1,255	405	0,107	14,34	4,30	8,22	2,31
R50C44 R50D44	800504 A.0318.LN A.0318.LN 800588		1,120	338	0,083	11,70	3,94	5,43	1,65
R50C45 R50D45	800508 A.0318.LN A.0318.LN 800588		1,236	402	0,110	13,08	4,14	9,08	2,52
R50C46 R50D46	800511 A.0318.LN A.0318.LN 800589		2,527	574	0,282	30,65	10,37	174,36	22,07
R50C47 R50D47	800511 A.0318.LN A.0318.LN 800590		2,645	638	0,309	33,93	11,98	194,80	23,73
R50C48 R50D48	800508 A.0318.LN A.0318.LN 800585		1,348	464	0,136	16,51	5,70	11,86	3,09
R50C49 R50D49	800514 A.0318.LN A.0318.LN 800591		1,532	448	0,156	19,17	7,01	27,16	5,64

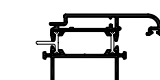
Le lettere C e D presenti nei codici sopra riportati stanno ad indicare rispettivamente:
C = profili interno ed esterno più barrette assemblati - es. R50C41
D = profili interno ed esterno più barrette non assemblati - es. R50D41
N.B.: I profilati sono forniti in lunghezza di 6800 mm

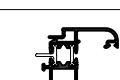
The letters C and D in the above codes indicate respectively:
C = Assembled internal and external sections with bars - ex. R50C41
D = Non assembled internal and external sections with bars - ex. R50D41
The sections are supplied with length of 6800 mm

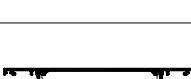

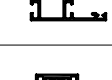
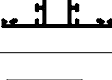
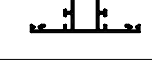
ELENCO PROFILATI
LIST OF SECTIONS

Profilato Section	Comp.ne Composition	Sezione Cross section	Peso Weight Kg/m	Perimetro Perimeter mm	Superficie in vista Exposed surface m ² /m	Jx cm ⁴	Wx cm ³	Jy cm ⁴	Wy cm ³
R50C50 R50D50	800514 A.0318.LN A.0318.LN 800592		1,419	386	0,131	16,17	5,47	20,34	4,57
R50C51 R50D51	800516 A.0318.LN A.0318.LN 800592		1,536	450	0,158	17,61	5,66	27,62	5,75
R50C52 R50D52	800516 A.0318.LN A.0318.LN 800591		1,649	512	0,183	20,97	7,24	33,41	6,58
R50C53 R50D53	800517 A.0317.LN A.0318.LN 800591		1,772	482	0,161	26,19	8,29	31,24	6,24
R50C54 R50D54	800514 A.0318.LN A.0318.LN 800593		1,742	400	0,153	19,95	7,61	36,91	7,40
R50C55 R50D55	800507 A.0317.LN A.0318.LN 800596		1,472	479	0,150	22,16	7,33	14,85	3,65
R50C56 R50D56	800516 A.0318.LN A.0318.LN 800594		1,792	487	0,214	15,61	7,42	41,59	8,67
R50C57 R50D57	800511 A.0318.LN A.0318.LN 800595		2,617	611	0,338	23,52	10,95	199,42	25,24
R50C58 R50D58	800538 A.0318.LN A.0318.LN 800613		1,267	417	0,102	14,05	5,20	8,54	2,36
R50C59 R50D59	800538 A.0318.LN A.0318.LN 800608		1,119	338	0,083	12,54	4,90	5,42	1,64
R50C60 R50D60	800538 A.0318.LN A.0318.LN 800597		1,236	402	0,110	14,61	5,24	9,05	2,51
R50C61 R50D61	800504 A.0318.LN A.0318.LN 800597		1,354	466	0,137	17,36	6,82	12,06	3,14
R50C62 R50D62	800540 A.0318.LN A.0318.LN 800598		1,536	450	0,158	19,44	7,31	27,60	5,75

Le lettere C e D presenti nei codici sopra riportati stanno ad indicare rispettivamente:
C = profili interno ed esterno più barrette assemblati - es. R50C41
D = profili interno ed esterno più barrette non assemblati - es. R50D41
N.B.: I profilati sono forniti in lunghezza di 6800 mm

The letters C and D in the above codes indicate respectively:
C = Assembled internal and external sections with bars - ex. R50C41
D = Non assembled internal and external sections with bars - ex. R50D41
The sections are supplied with length of 6800 mm

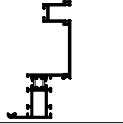

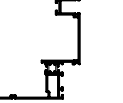
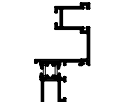
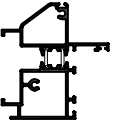
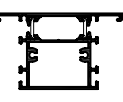
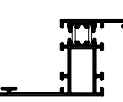
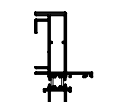
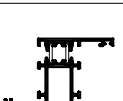
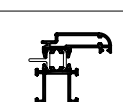
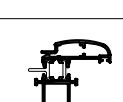
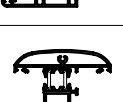



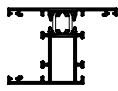
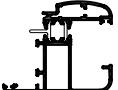
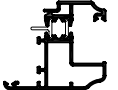

ELENCO PROFILATI
LIST OF SECTIONS

Profilato Section	Comp.ne Composition	Sezione Cross section	Peso Weight Kg/m	Perimetro Perimeter mm	Superficie in vista Exposed surface m ² /m	Jx cm ⁴	Wx cm ³	Jy cm ⁴	Wy cm ³
R50C63 R50D63	800514 A.0318.LN A.0318.LN 800599		1,492	373	0,159	12,26	5,69	24,26	5,96
R50C64 R50D64	800547 A.0318.LN A.0318.LN 800585		1,977	713	0,126	131,27	17,11	22,45	4,87
R50C65 R50D65	800548 A.0318.LN A.0318.LN 800585		1,830	649	0,094	64,10	11,43	18,73	4,26
R50C66 R50D66	800547 A.0318.LN A.0318.LN 800705		2,163	794	0,166	153,33	18,67	68,69	8,08
R50C67 R50D67	800548 A.0318.LN A.0318.LN 800705		2,016	730	0,134	78,20	12,86	62,25	7,55
R50C68 R50D68	800602 A.0318.LN A.0318.LN 800601		1,693	449	0,102	29,66	7,44	16,64	3,70
R50C69 R50D69	800516 A.0318.LN A.0318.LN 800603		1,694	450	0,158	18,05	5,97	29,36	6,12
R50C70 R50D70	800504 A.0318.LN A.0318.LN 800604		1,427	492	0,143	18,68	7,01	28,20	4,46
R50C71 R50D71	800575 A.0318.LN A.0318.LN 800605		2,112	615	0,162	96,50	17,12	11,19	2,99
R50C72 R50D72	800504 A.0318.LN A.0318.LN 800607		1,264	409	0,114	15,10	5,70	10,03	2,73
R50C73 R50D73	800618 A.0317.LN A.0318.LN 800585		1,384	414	0,114	19,09	6,31	11,11	2,89
R50C75 R50D75	800621 A.0317.LN A.0318.LN 800585		1,438	418	0,116	20,47	6,54	11,42	2,94
R50C76 R50D76	800622 A.0318.LN A.0318.LN 800586		1,583	417	0,114	21,34	5,44	12,08	3,48

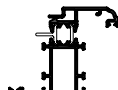
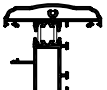
Le lettere C e D presenti nei codici sopra riportati stanno ad indicare rispettivamente:
C = profili interno ed esterno più barrette assemblati - es. R50C41
D = profili interno ed esterno più barrette non assemblati - es. R50D41
N.B.: I profilati sono forniti in lunghezza di 6800 mm

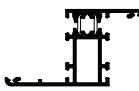
The letters C and D in the above codes indicate respectively:
C = Assembled internal and external sections with bars - ex. R50C41
D = Non assembled internal and external sections with bars - ex. R50D41
The sections are supplied with length of 6800 mm

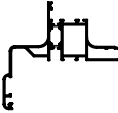
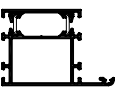
ELENCO PROFILATI
LIST OF SECTIONS

Profilato Section	Comp.ne Composition	Sezione Cross section	Peso Weight Kg/m	Perimetro Perimeter mm	Superficie in vista Exposed surface m ² /m	Jx cm ⁴	Wx cm ³	Jy cm ⁴	Wy cm ³
R50C77 R50D77	800508 A.0318.LN A.0318.LN 800608		1,353	471	0,137	16,65	5,78	12,08	3,14
R50C79 R50D79	800621 A.0317.LN A.0318.LN 800596		1,539	457	0,152	23,67	7,60	15,51	3,74
R50C80 R50D80	800628 A.0317.LN A.0318.LN 800627		1,401	427	0,138	19,53	6,51	11,60	2,97
R50C81 R50D81	800648 A.0318.LN A.0318.LN 800588		1,332	395	0,088	16,88	4,88	7,57	2,37
R50C82 R50D82	800648 A.0318.LN A.0318.LN 800585		1,444	457	0,114	21,04	6,61	11,25	3,00
R50C83 R50D83	800649 A.0317.LN A.0318.LN 800585		1,374	447	0,115	19,44	6,41	10,63	2,80
R50C84 R50D84	800650 A.0318.LN A.0318.LN 800586		1,596	415	0,117	21,40	5,44	12,50	3,60
R50C85 R50D85	800618 A.0317.LN A.0318.LN 800596		1,490	458	0,150	22,03	7,30	15,23	3,70
R50C86 R50D86	800504 A.0318.LN A.0318.LN 800701		1,322	458	0,127	16,52	6,50	15,43	3,02
R50C87 R50D87	800504 A.0318.LN A.0318.LN 800659		1,478	518	0,156	19,68	7,14	40,73	5,59
R50C88 R50D88	800690 A.0318.LN A.0318.LN 800689		2,707	857	0,267	158,56	19,03	77,14	10,19
R50C89 R50D89	800540 A.0318.LN A.0318.LN 800591		1,419	384	0,131	17,01	6,69	19,90	4,45
R50C90 R50D90	800504 A.0318.LN A.0318.LN 800608		1,241	402	0,110	14,82	5,52	9,07	2,52

Le lettere C e D presenti nei codici sopra riportati stanno ad indicare rispettivamente:
C = profili interno ed esterno più barrette assemblati - es. R50C41
D = profili interno ed esterno più barrette non assemblati - es. R50D41
N.B.: I profilati sono forniti in lunghezza di 6800 mm



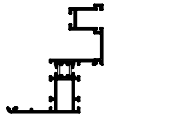
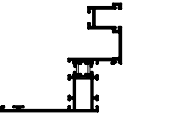
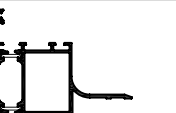
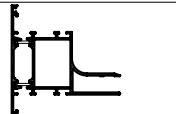
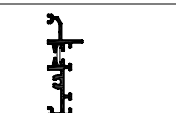
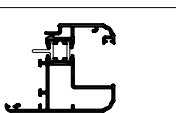
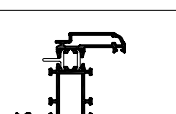
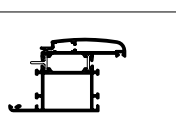
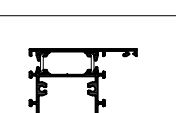
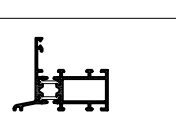
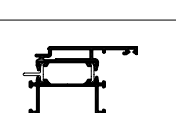
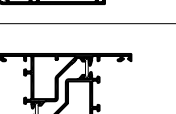
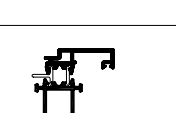

The letters C and D in the above codes indicate respectively:
C = Assembled internal and external sections with bars - ex. R50C41
D = Non assembled internal and external sections with bars - ex. R50D41
The sections are supplied with length of 6800 mm

ELENCO PROFILATI
LIST OF SECTIONS

Profilato Section	Comp.ne Composition	Sezione Cross section	Peso Weight Kg/m	Perimetro Perimeter mm	Superficie in vista Exposed surface m ² /m	Jx cm ⁴	Wx cm ³	Jy cm ⁴	Wy cm ³
R50C91 R50D91	800548 A.0318.LN A.0318.LN 800701		1,920	688	0,112	69,53	12,00	27,74	4,66
R50C92 R50D92	800548 A.0318.LN A.0318.LN 800659		2,041	766	0,189	80,09	13,00	61,08	7,35
R50C94 R50D94	800514 A.0318.LN A.0318.LN 800727		1,909	545	0,150	26,59	5,34	48,44	8,49
R50C95 R50D95	800516 A.0318.LN A.0318.LN 800727		2,026	609	0,177	32,36	6,22	52,49	8,90
R50C96 R50D96	800730 A.0318.LN 800731		0,859	320	0,016	11,30	3,29	0,62	0,41
R50C97 R50D97	800649 A.0317.LN A.0318.LN 800739		1,520	454	0,151	22,12	7,34	15,39	3,73
R50C98 R50D98	800722 A.0317.LN A.0318.LN 800585		1,387	476	0,138	18,96	6,29	10,98	2,87
R50C100 R50D100	800770 A.0317.LN A.0318.LN 800591		1,819	577	0,165	27,79	6,90	32,70	5,68
R50C101 R50D101	800514 A.0318.LN A.0318.LN 800603		1,581	386	0,131	16,45	5,72	22,08	4,92
R50C102 R50D102	800786 A.0318.LN A.0318.LN 800588		1,173	404	0,098	5,75	1,71	13,77	4,11
R50C103 R50D103	800788 A.0317.LN A.0318.LN 800591		1,765	592	0,157	26,63	8,40	27,88	5,70
R50C104 R50D104	800797 A.0318.LN A.0318.LN 800796		1,853	449	0,158	21,24	7,54	28,40	5,92
R50C105 R50D105	800802 A.0317.LN A.0318.LN 800585		1,380	451	0,120	19,63	6,43	11,05	2,90

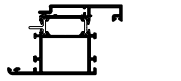
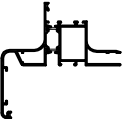
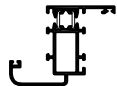
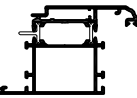
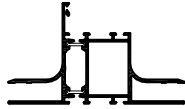
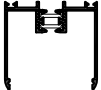
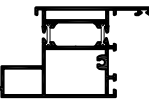
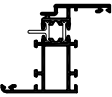
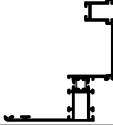
Le lettere C e D presenti nei codici sopra riportati stanno ad indicare rispettivamente:
C = profili interno ed esterno più barrette assemblati - es. R50C41
D = profili interno ed esterno più barrette non assemblati - es. R50D41
N.B.: I profilati sono forniti in lunghezza di 6800 mm

The letters C and D in the above codes indicate respectively:
C = Assembled internal and external sections with bars - ex. R50C41
D = Non assembled internal and external sections with bars - ex. R50D41
The sections are supplied with length of 6800 mm

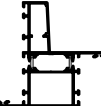
Profilato Section	Comp.ne Composition	Sezione Cross section	Peso Weight Kg/m	Perimetro Perimeter mm	Superficie in vista Exposed surface m ² /m	Jx cm ⁴	Wx cm ³	Jy cm ⁴	Wy cm ³
R50C106 R50D106	800805 A.0317.LN A.0318.LN 800591		1,780	495	0,163	26,51	8,35	31,86	6,32
R50C107 R50D107	800689 A.0318.LN A.0318.LN 800806		2,852	863	0,267	82,76	10,99	164,01	19,32
R50C108 R50D108	800504 A.0318.LN A.0318.LN 800825		1,377	465	0,132	20,28	6,49	13,82	3,57
R50C109 R50D109	800827 A.0317.LN A.0318.LN 800591		1,782	506	0,165	26,43	8,33	31,49	6,26
R50C110 R50D110	800828 A.0318.LN A.0318.LN 800727		2,375	717	0,163	30,77	5,84	87,29	12,99
R50C111 R50D111	800830 A.0318.LN A.0318.LN 800830		1,078	409	0,105	8,26	2,26	16,12	5,70
R50C112 R50D112	800832 A.0318.LN A.0318.LN 800593		1,955	429	0,153	28,94	9,50	39,07	7,90
R50C113 R50D113	800831 A.0317.LN A.0318.LN 800585		1,328	436	0,115	19,11	6,42	8,87	2,42
R50C114 R50D114	800547 A.0318.LN A.0318.LN 800659		2,227	834	0,170	194,59	20,33	68,71	8,09
R50C115 R50D115	800504 A.0318.LN A.0318.LN 800835		1,069	316	0,061	9,55	3,03	4,97	1,55
R50C121 R50D121	800508 A.0318.LN A.0318.LN 800852		1,322	406	0,132	13,36	4,30	9,11	2,52
R50C122 R50D122	800504 A.0318.LN A.0318.LN 800852		1,206	347	0,087	11,87	4,06	5,47	1,65
R50C123 R50D123	800859 A.0318.LN A.0318.LN 800591		2,093	591	0,165	58,89	10,72	31,66	6,13

Le lettere C e D presenti nei codici sopra riportati stanno ad indicare rispettivamente:
C = profili interno ed esterno più barrette assemblati - es. R50C41
D = profili interno ed esterno più barrette non assemblati - es. R50D41
N.B.: I profilati sono forniti in lunghezza di 6800 mm

The letters C and D in the above codes indicate respectively:
C = Assembled internal and external sections with bars - ex. R50C41
D = Non assembled internal and external sections with bars - ex. R50D41
The sections are supplied with length of 6800 mm

ELENCO PROFILATI
LIST OF SECTIONS

Profilato Section	Comp.ne Composition	Sezione Cross section	Peso Weight Kg/m	Perimetro Perimeter mm	Superficie in vista Exposed surface m ² /m	Jx cm ⁴	Wx cm ³	Jy cm ⁴	Wy cm ³
R50C129 R50D129	800828 A.0318.LN A.0318.LN 800592		1,889	546	0,147	37,97	7,59	26,59	5,36
R50C144 R50D144	800917 A.0318.LN A.0318.LN 800588		1,385	405	0,059	18,23	5,12	7,55	2,34
R50C145 R50D145	800917 A.0318.LN A.0318.LN 800585		1,497	466	0,111	22,69	6,89	11,18	2,99
R50C146 R50D146	800918 A.0318.LN A.0318.LN 800592		1,798	432	0,139	25,40	7,06	26,90	6,10
R50C147 R50D147	800918 A.0318.LN A.0318.LN 800591		1,911	494	0,167	30,03	8,86	33,95	6,88
R50C153 R50D153	800690 A.0318.LN A.0318.LN 800925		2,334	694	0,248	76,51	10,00	95,18	17,62
R50C158 R50D158	800831 A.0317.LN A.0318.LN 800608		1,334	438	0,110	19,26	6,50	9,11	2,49

Le lettere C e D presenti nei codici sopra riportati stanno ad indicare rispettivamente:
C = profili interno ed esterno più barrette assemblati - es. R50C41
D = profili interno ed esterno più barrette non assemblati - es. R50D41
N.B.: I profilati sono forniti in lunghezza di 6800 mm

The letters C and D in the above codes indicate respectively:
C = Assembled internal and external sections with bars - ex. R50C41
D = Non assembled internal and external sections with bars - ex. R50D41
The sections are supplied with length of 6800 mm

ELENCO PROFILATI
LIST OF SECTIONS

Profilato Section	Sezione Cross section	Peso Weight Kg/m	Perim. Perim. mm	Sup. in vista Expose surface m /m ²	Profilato Section	Sezione Cross section	Peso Weight Kg/m	Perim. Perim. mm	Sup. in vista Expose surface m /m ²
100009		0.234	82	0.029	800585		0.758	284	0.054
100342		0.143	64	0.025	800586		0.710	247	0.034
800129		0.324	182	0.074	800587		0.461	213	0.073
800291		0.629	231	0.080	800588		0.646	221	0.028
800504		0.390	172	0.055	800589		1.519	395	0.114
800507		0.497	193	0.060	800590		1.637	459	0.141
800508		0.506	236	0.082	800591		0.942	333	0.077
800511		0.924	409	0.168	800592		0.829	271	0.052
800514		0.506	221	0.079	800593		1.148	285	0.074
800516		0.623	285	0.106	800594		1.085	308	0.108
800517		0.714	239	0.084	800595		1.609	432	0.170
800538		0.272	108	0.028	800596		0.859	328	0.090
800540		0.389	157	0.052	800597		0.880	350	0.082
800547		1.135	485	0.072	800598		1.063	399	0.106
800548		0.988	420	0.040	800599		0.902	257	0.080
800575		1.315	416	0.125	800601		0.830	241	0.043
800581		0.314	163	0.015	800603		0.987	271	0.052

ELENCO PROFILATI
LIST OF SECTIONS







Profilato Section	Sezione Cross section	Peso Weight Kg/m	Perim. Perim. mm	Sup. in vista Expose surface m /m ²	Profilato Section	Sezione Cross section	Peso Weight Kg/m	Perim. Perim. mm	Sup. in vista Expose surface m /m ²
800604		0.949	376	0.088	800650		0,802	222	0.083
800605		0.713	258	0.037	800659		1,004	518	0.156
800607		0.790	292	0.059	800689		1.188	423	0.071
800608		0.763	285	0.055	800690		1.431	531	0.196
800609		0.984	343	0.074	800701		0.844	324	0.072
800610		0.450	120	0.057	800705		0.940	366	0.094
800611		0.960	245	0.113	800722		0.513	164	0.061
800612		1.084	271	0.139	800727		1.315	431	0.071
800613		0.911	363	0.074	800728		0.297	122	0.042
800617		1,370	381	0.206	800729		0.383	159	0.058
800618		0,515	163	0.060	800730		0.297	131	0.000
800621		0,569	162	0.062	800731		0.497	197	0.016
800622		0,789	219	0.080	800737		0.980	333	0.105
800627		0,826	278	0.083	800738		0,170	92	0.027
800628		0,464	176	0.055	800739		0,899	291	0,090
800648		0,605	229	0.060	800759		1,370	469	0,188
800649		0,505	197	0.061	800760		1,043	354	0,185

ELENCO PROFILATI
LIST OF SECTIONS

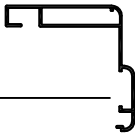
Profilato Section	Sezione Cross section	Peso Weight Kg/m	Perim. Perim. mm	Sup. in vista Expose surface m /m ²	Profilato Section	Sezione Cross section	Peso Weight Kg/m	Perim. Perim. mm	Sup. in vista Expose surface m /m ²
800761		1,193	389	0,165	800830		0,495	221	0,054
800762		1,542	540	0,222	800831		0,455	175	0,055
800770		0,761	210	0,087	800832		0,719	236	0,085
800780		0,432	216	0,027	800835		0,591	201	0,006
800786		0,440	194	0,073	800839		0,498	188	0,080
800788		0,707	229	0,080	800852		0,728	222	0,030
800789		0,818	300	0,102	800859		1,063	356	0,110
800796		0,769	235	0,052	800917		0,651	234	0,065
800797		0,996	362	0,106	800918		0,881	286	0,088
800802		0,507	197	0,065	800925		0,815	259	0,052
800804		0,779	263	0,059	900106		0,262	152	0,062
800805		0,722	245	0,084	900162		0,370	202	0,070
800806		1,577	101	0,190	900221		0,167	57	0,015
800822		0,228	128	0,062	900316		0,213	133	0,068
800825		0,899	349	0,065	900317		0,850	312	0,055
800827		0,724	246	0,084	900318		0,786	285	0,052
800828		0,972	383	0,095	900319		0,413	138	0,000

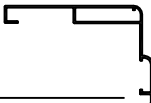

ELENCO PROFILATI
LIST OF SECTIONS

R 50^{TT}
SYSTEM

Profilato Section	Sezione Cross section	Peso Weight Kg/m	Perim. Perim. mm	Sup. in vista Expose surface m /m ²	Profilato Section	Sezione Cross section	Peso Weight Kg/m	Perim. Perim. mm	Sup. in vista Expose surface m /m ²
900362		0,440	187	0,000	900602		0,980	381	0,156
900390		0,286	104	0,030	1F14039		0,411	103	0,000
900424		0,220	93	0,037	1F14041		0,633	199	0,000
900600		1,102	441	0,186	1F14042		0,141	77	0,000
900601		0,820	302	0,136					

ELENCO BARRETTE IN POLIAMMIDE
LIST OF REINFORCED POLYAMIDE BARS

R 50^{TT}
SYSTEM

Codice Code	Sezione Cross section	Peso Weight Kg/m
A.0317.LN		0,069
A.0318.LN		0,043

Scala 1:1
Scale 1:1

A.0317.LN

A.0318.LN



N.B.: I profilati sono forniti in lunghezza di 6800 mm

The sections are supplied with length of 6800 mm

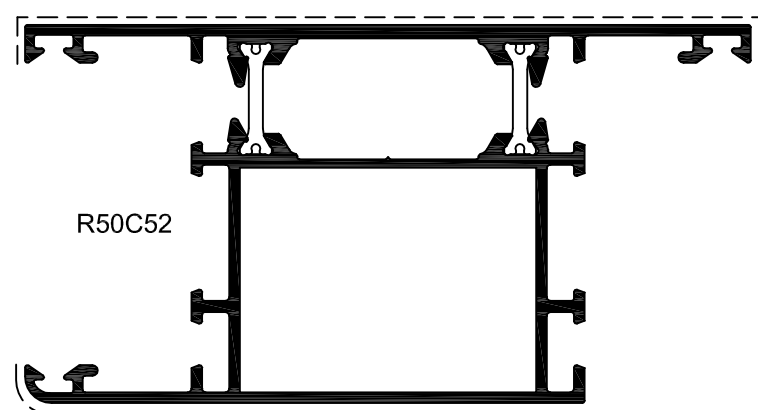
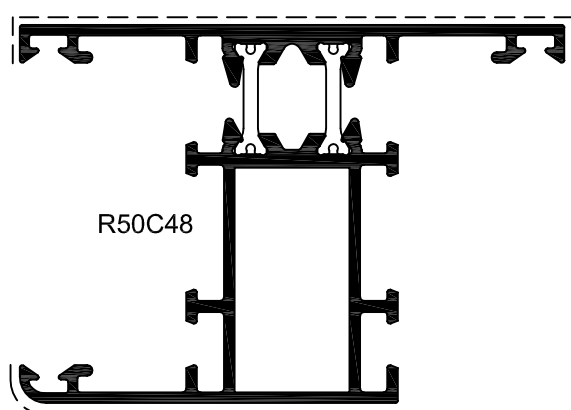
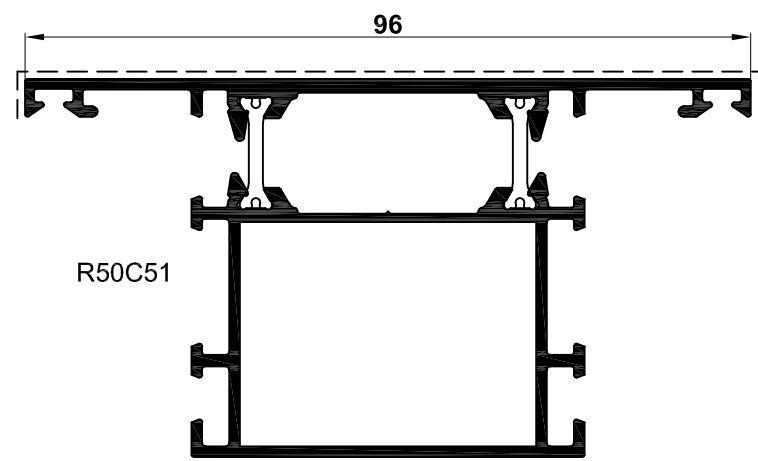
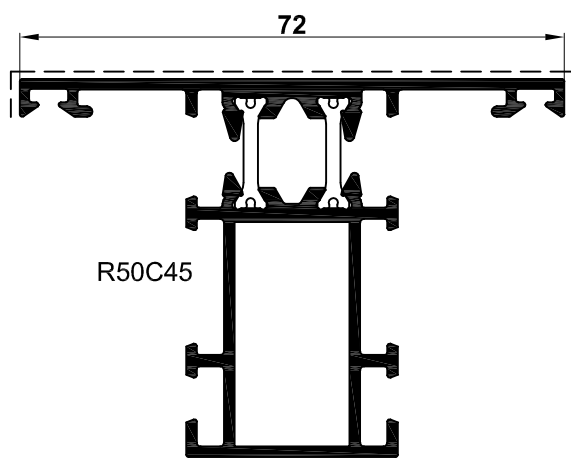
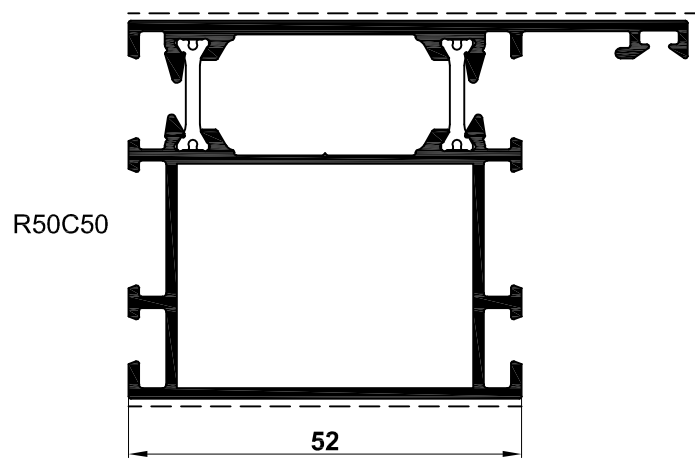
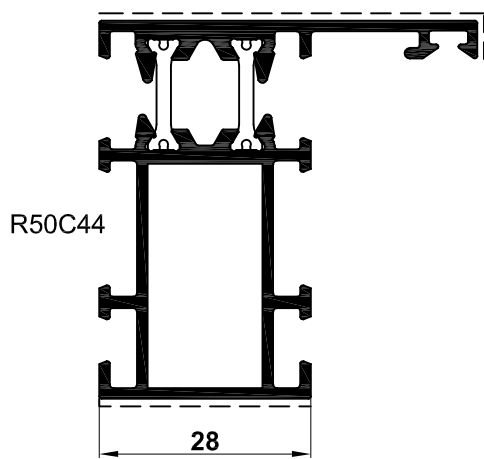
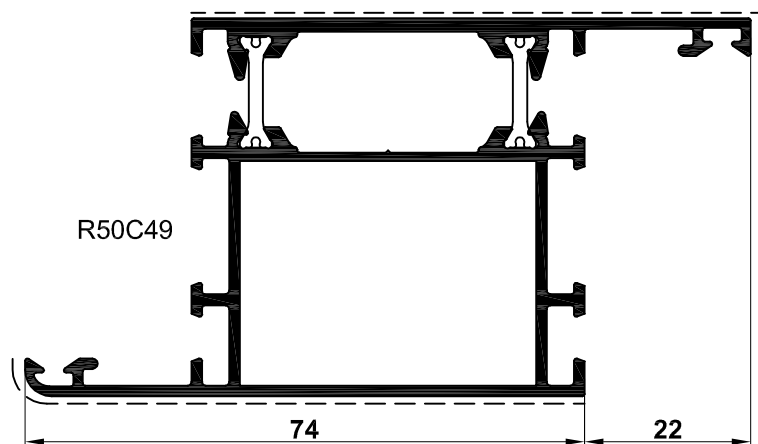
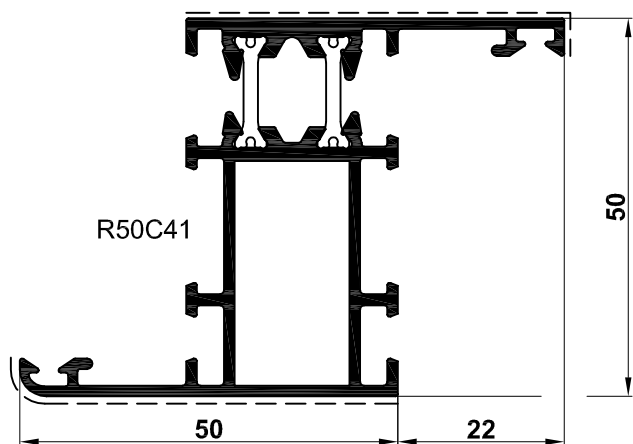

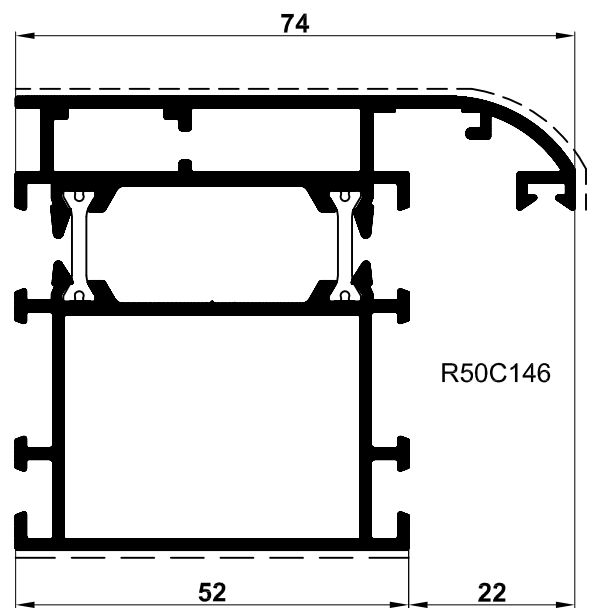
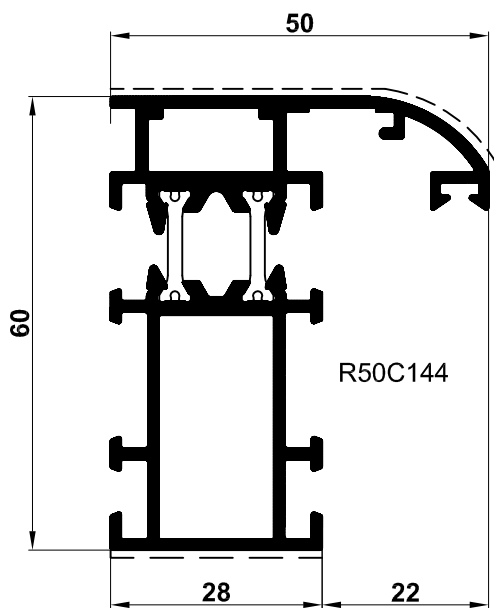
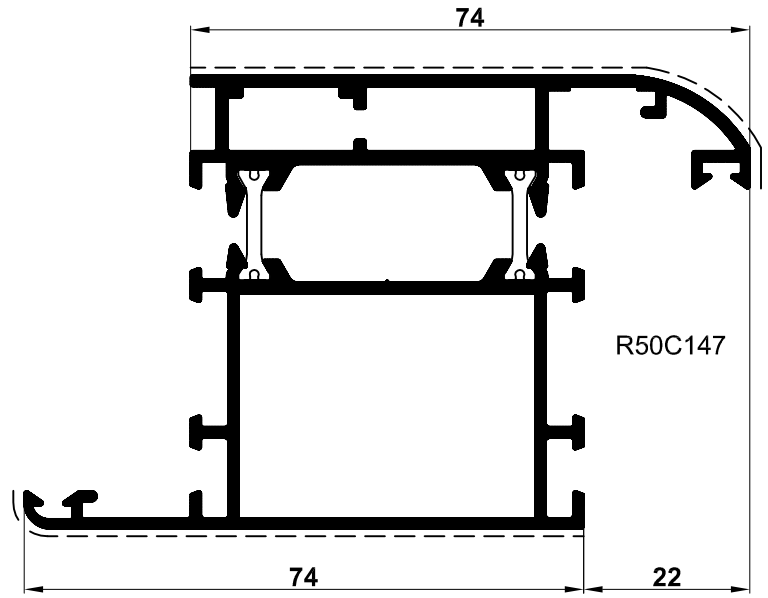
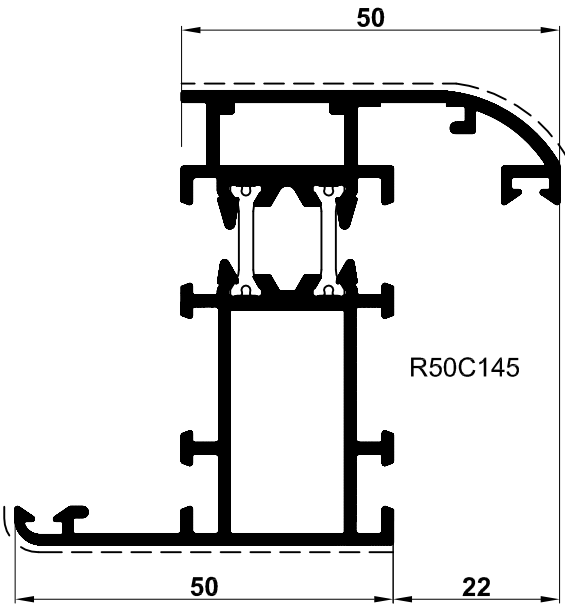
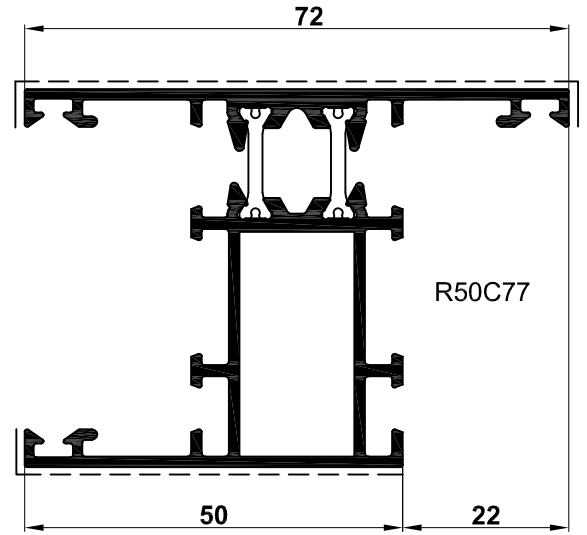
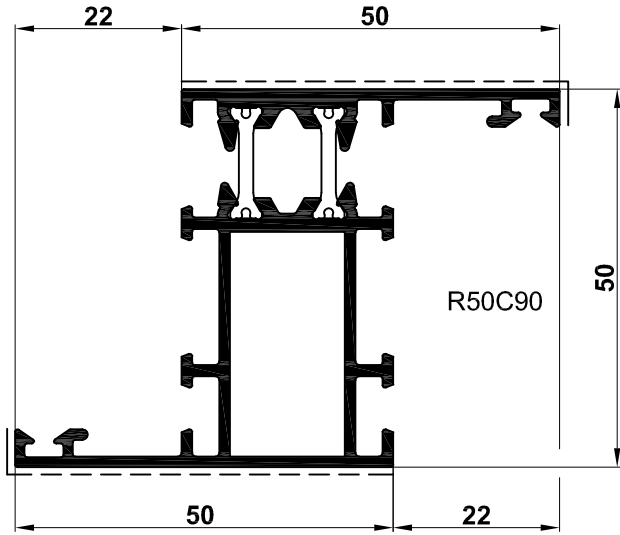

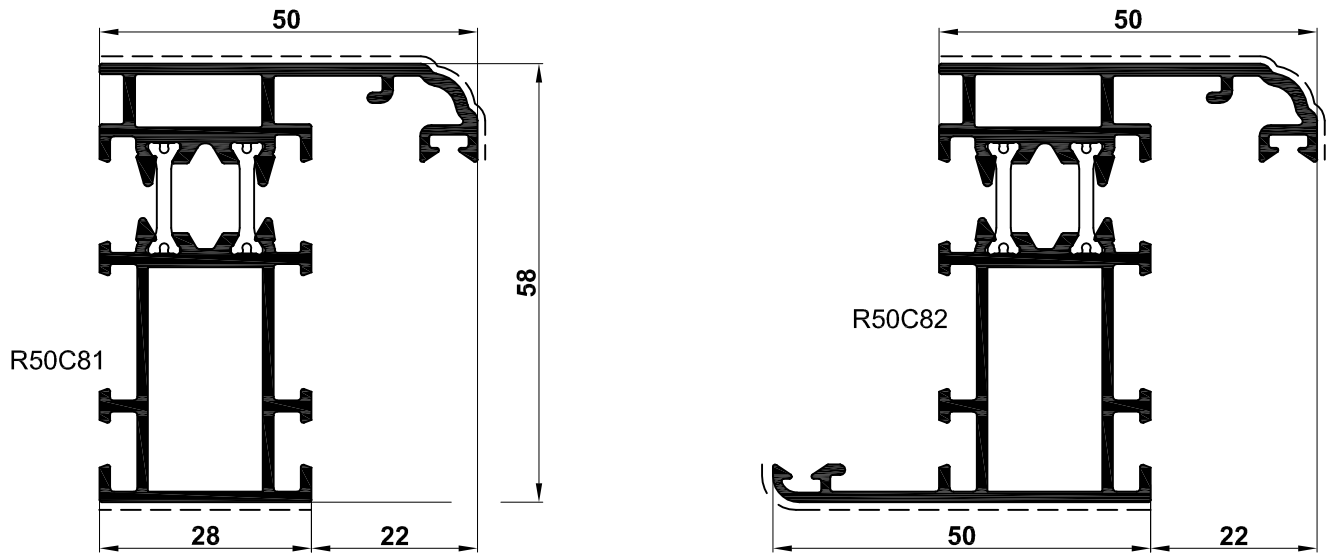

TELAJ SPECIALI
SPECIAL FRAMES

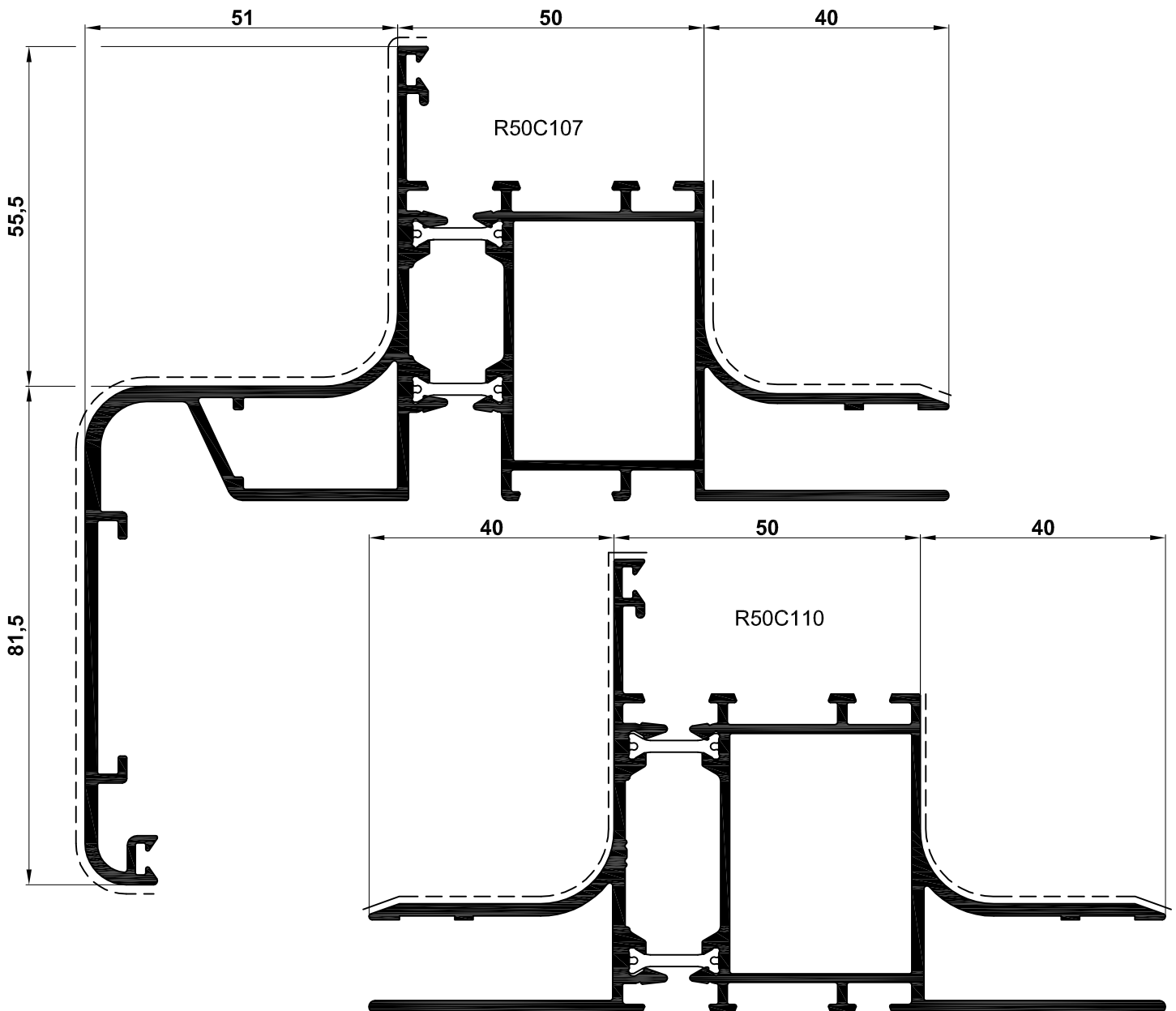

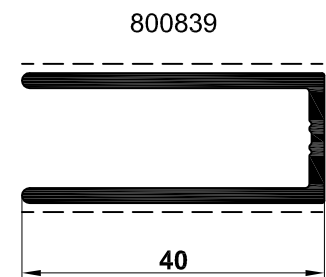
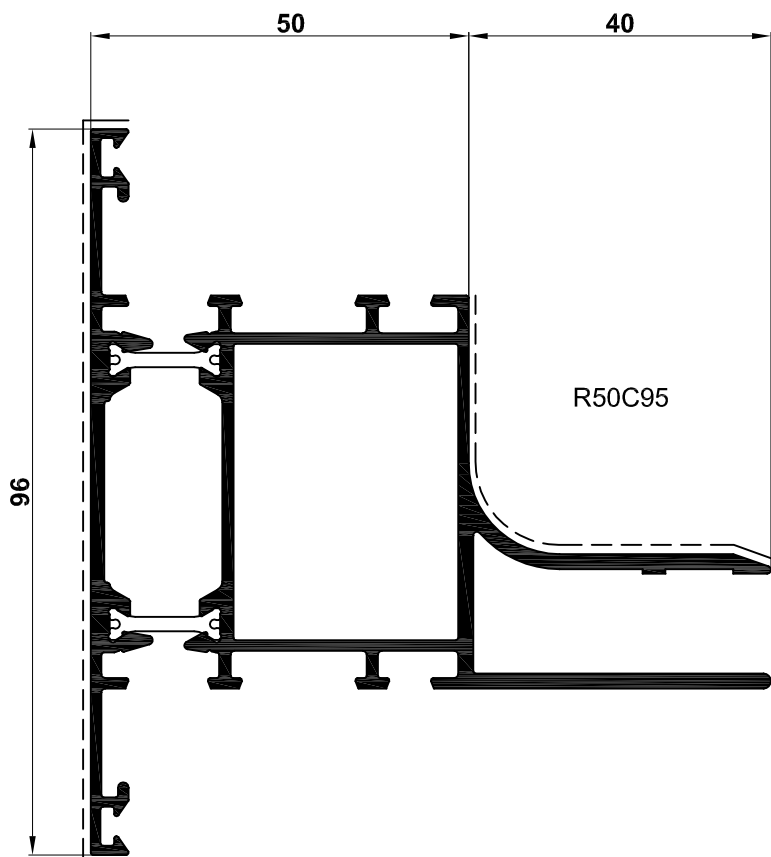
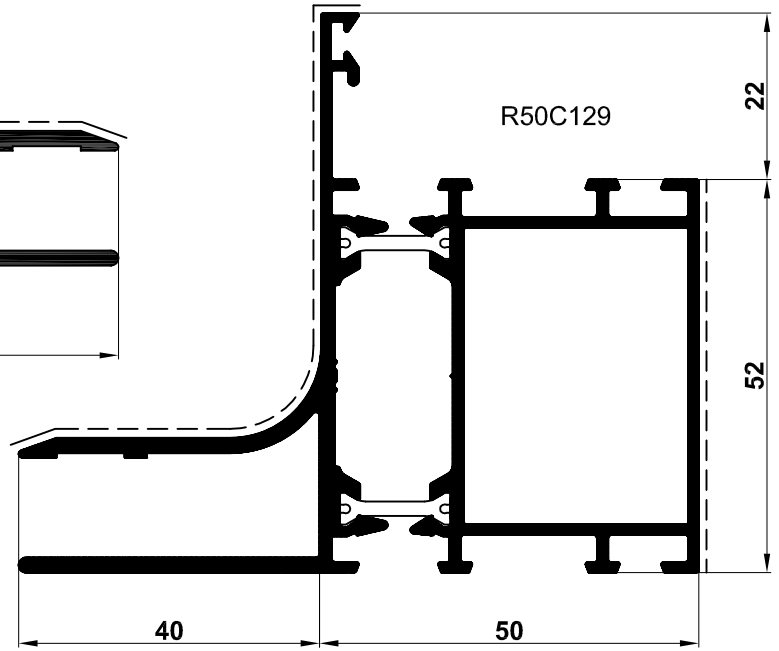
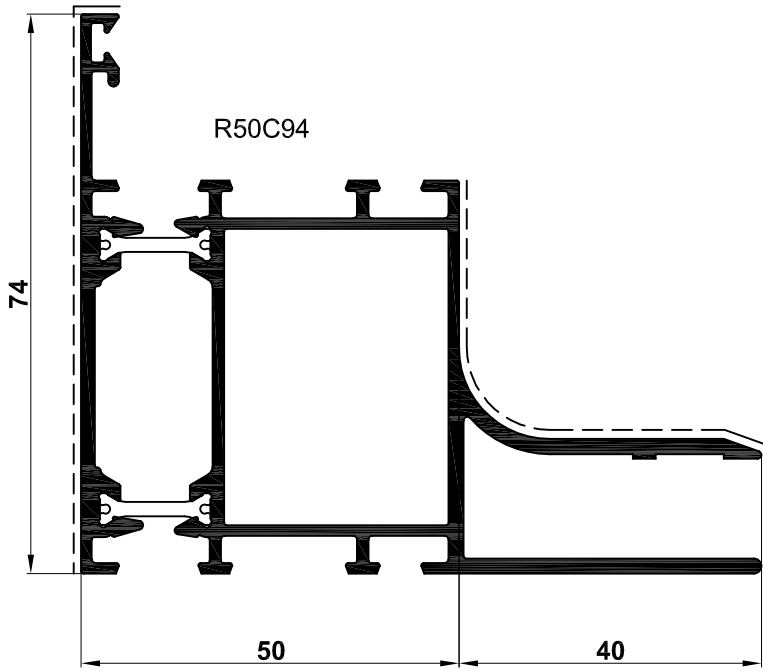

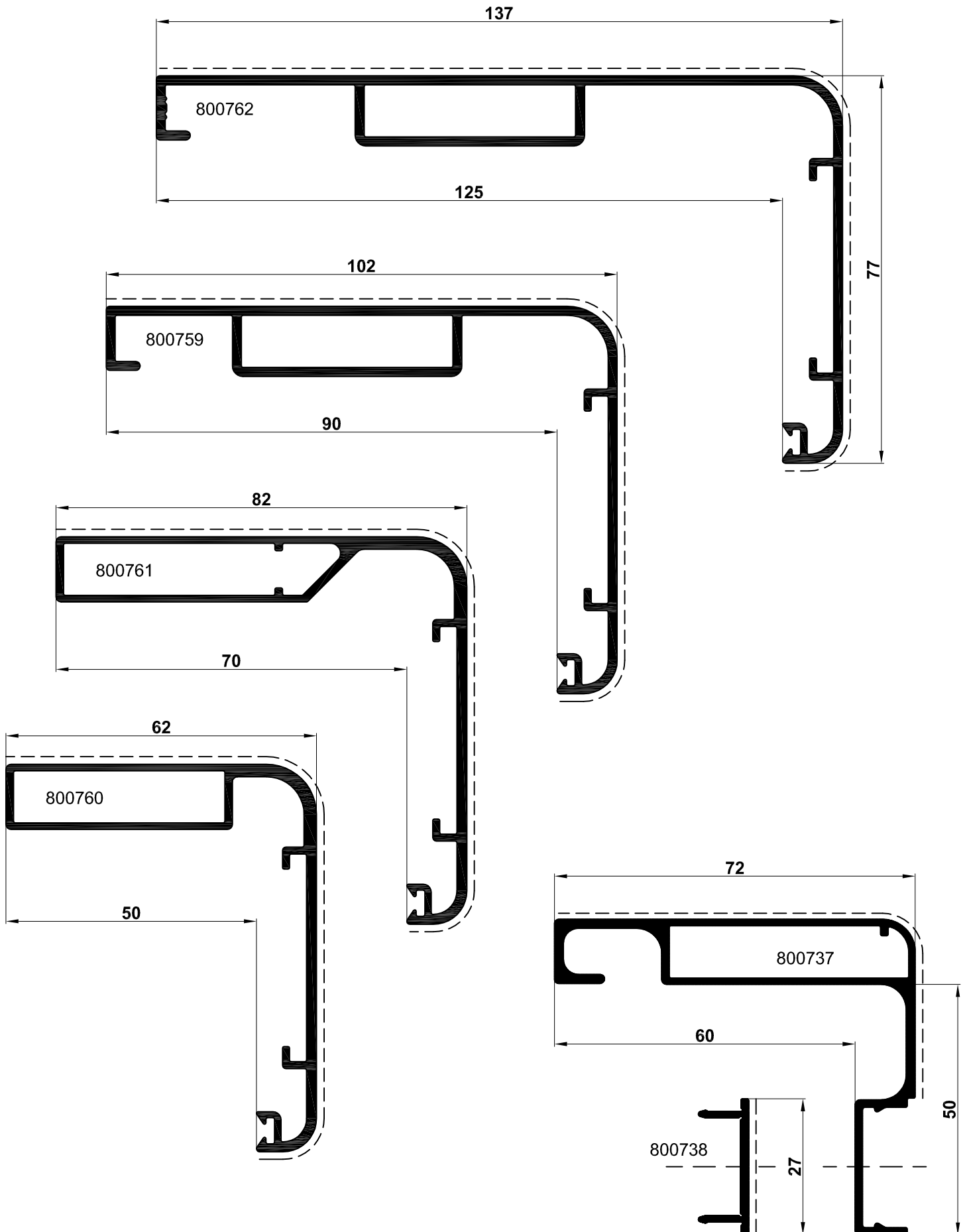

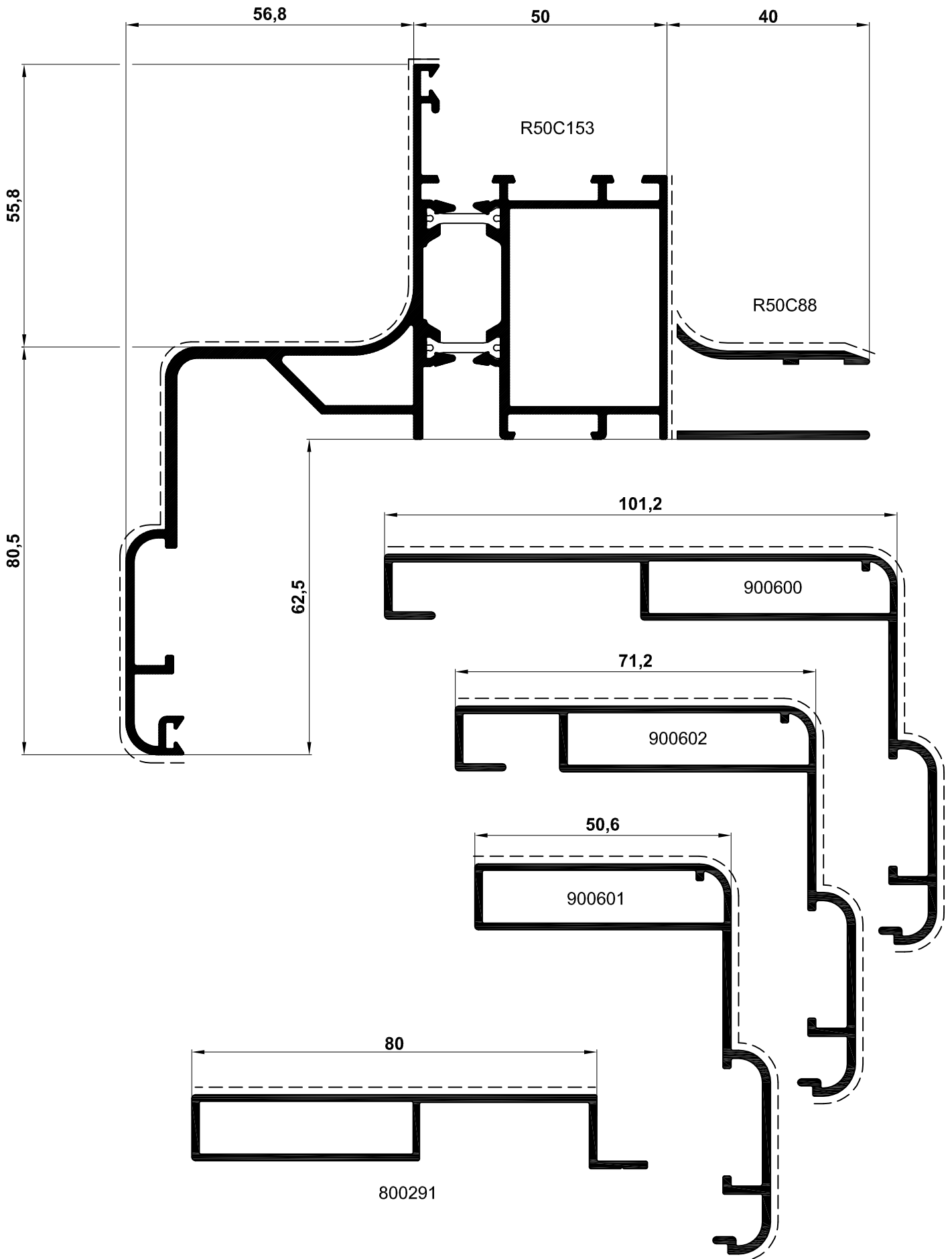

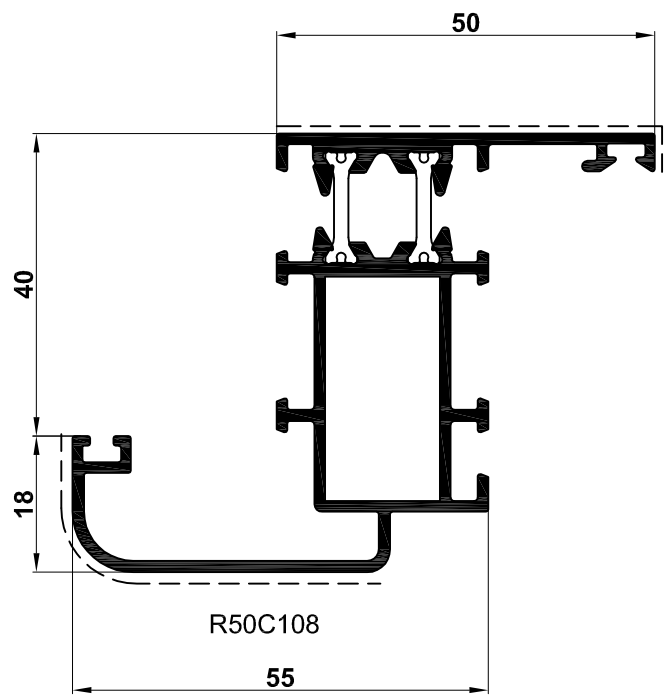
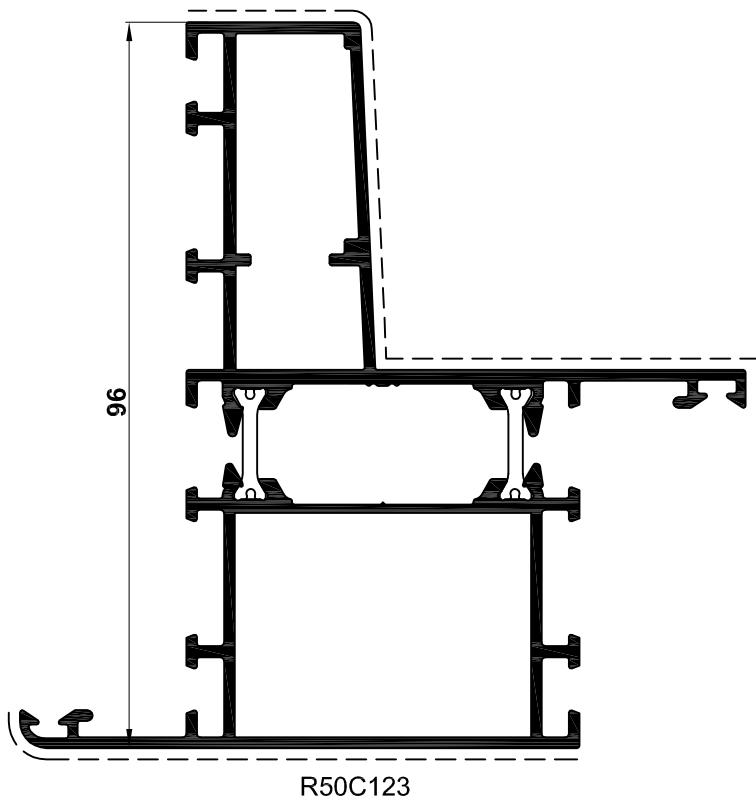
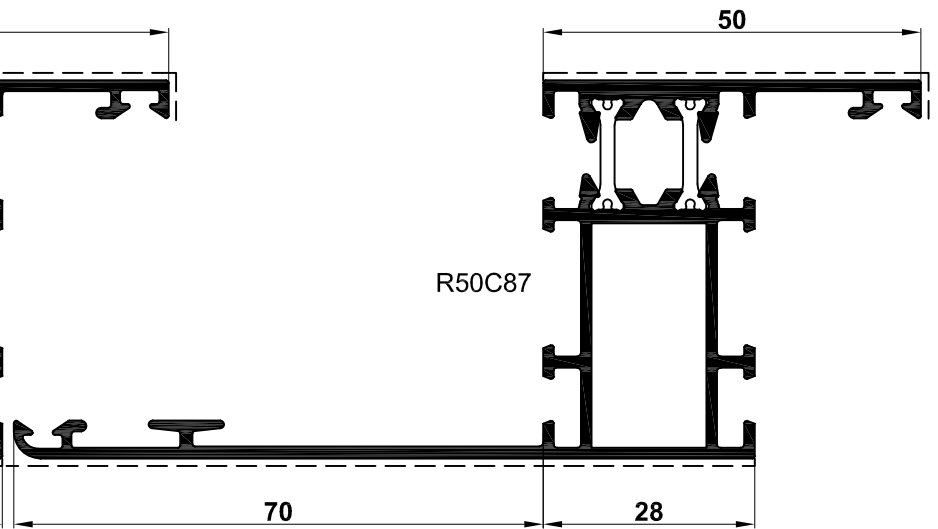
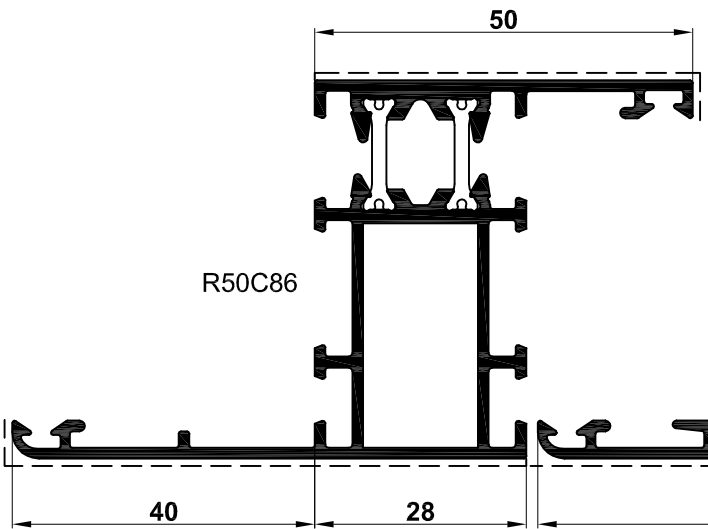
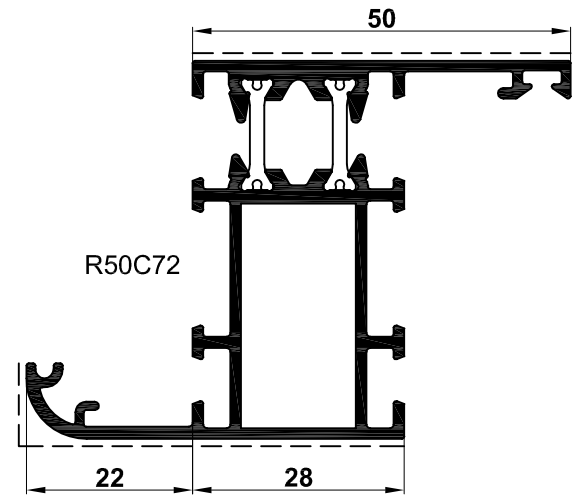
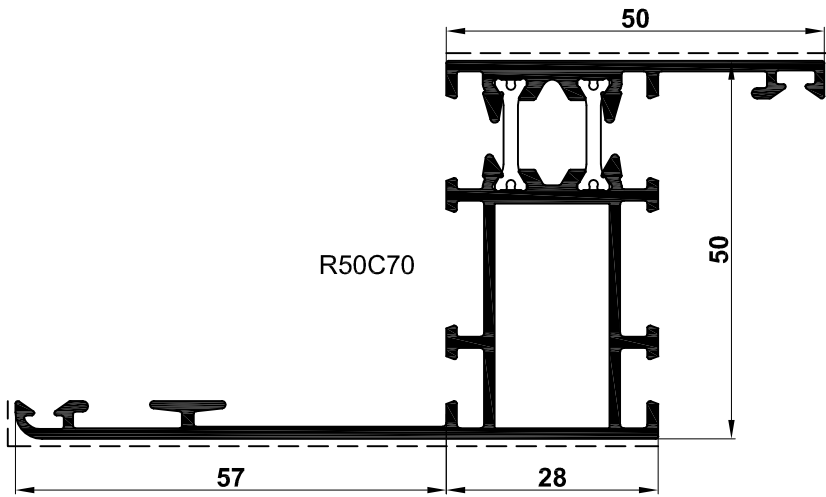

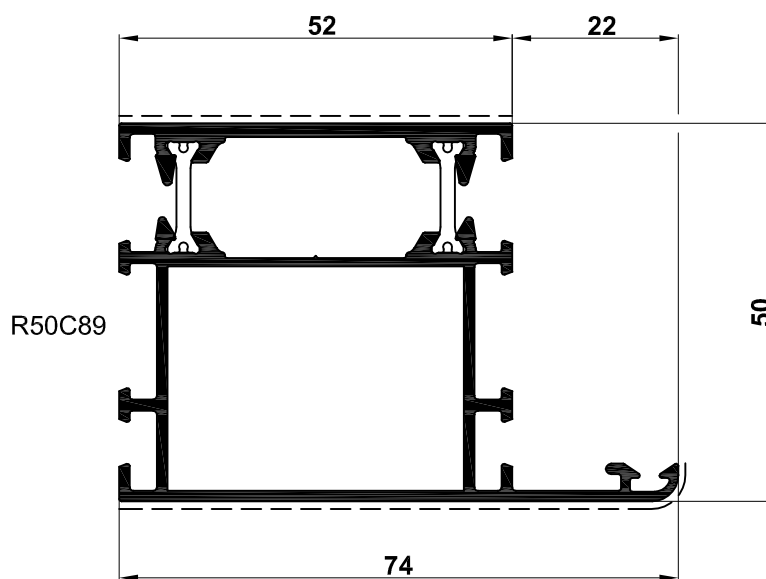
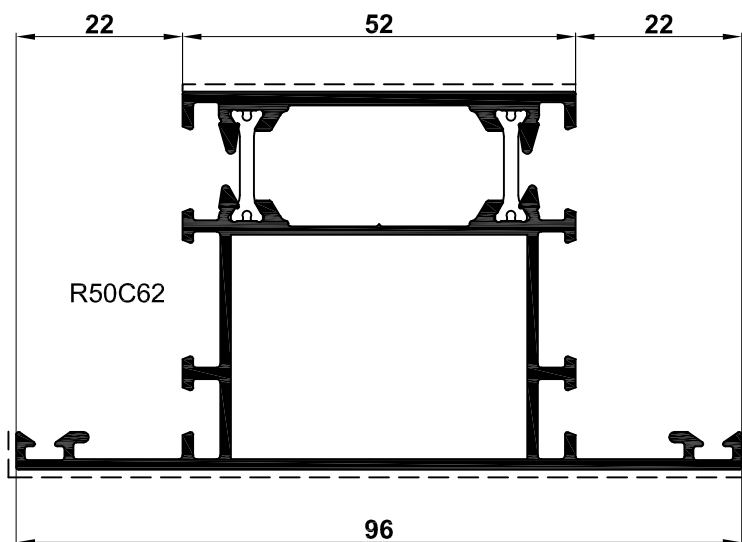
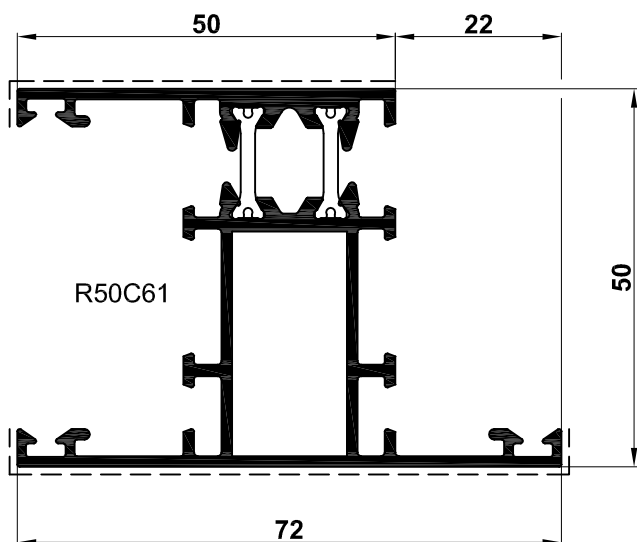
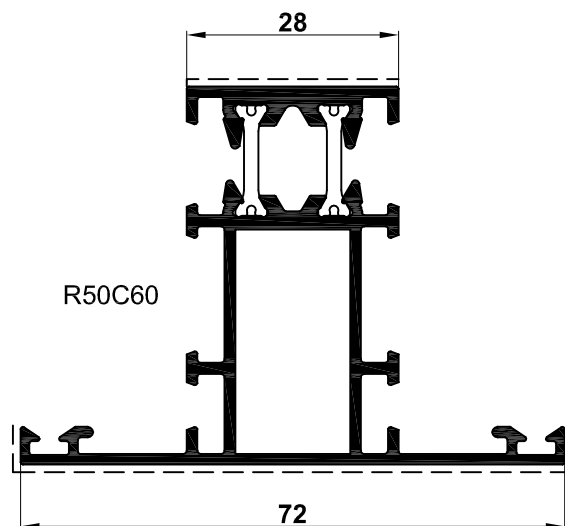
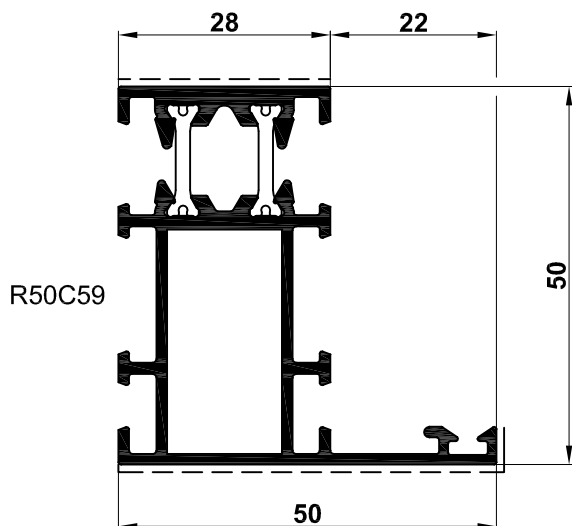

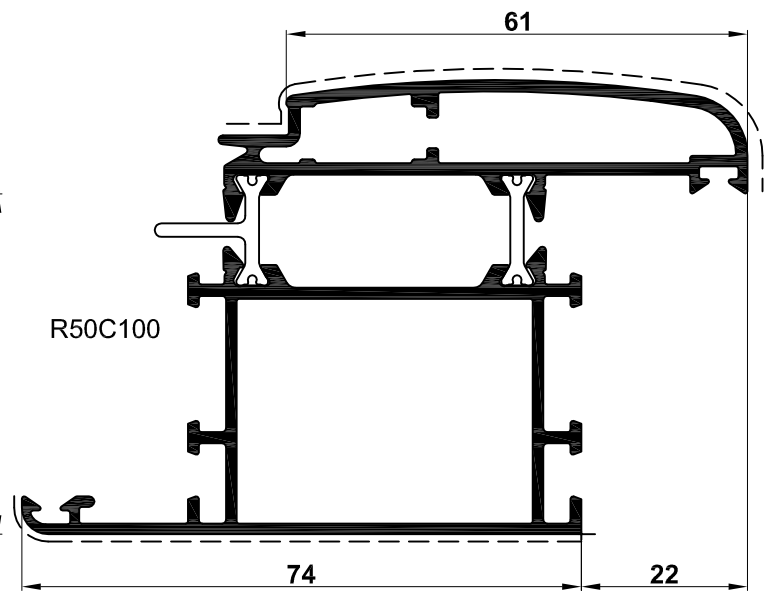
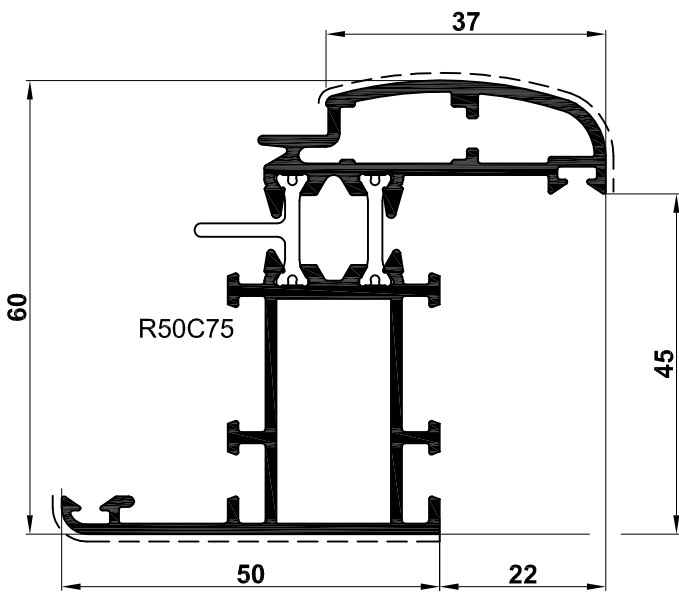
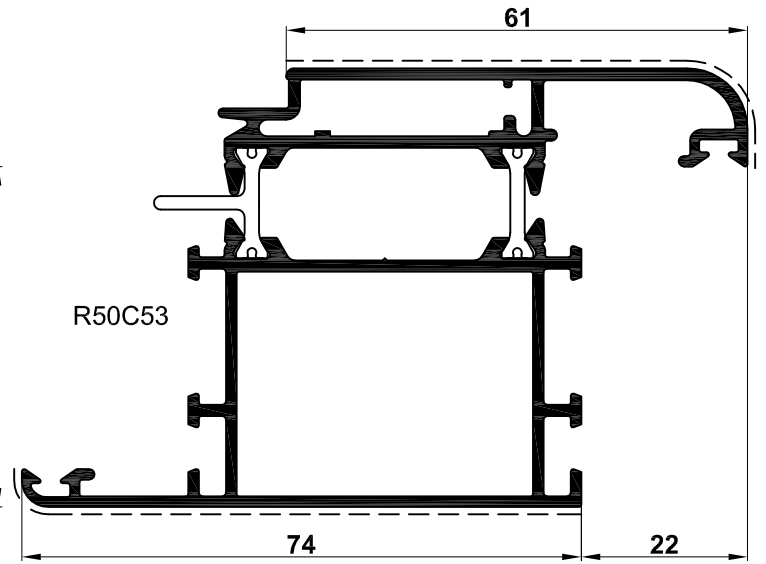
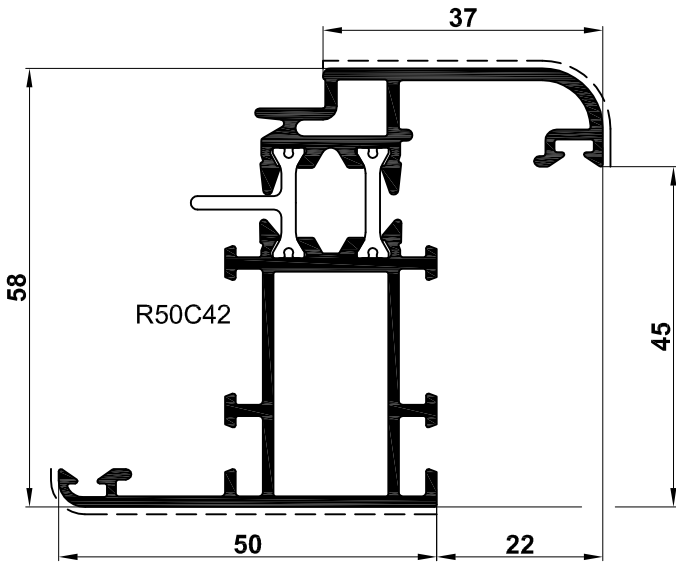
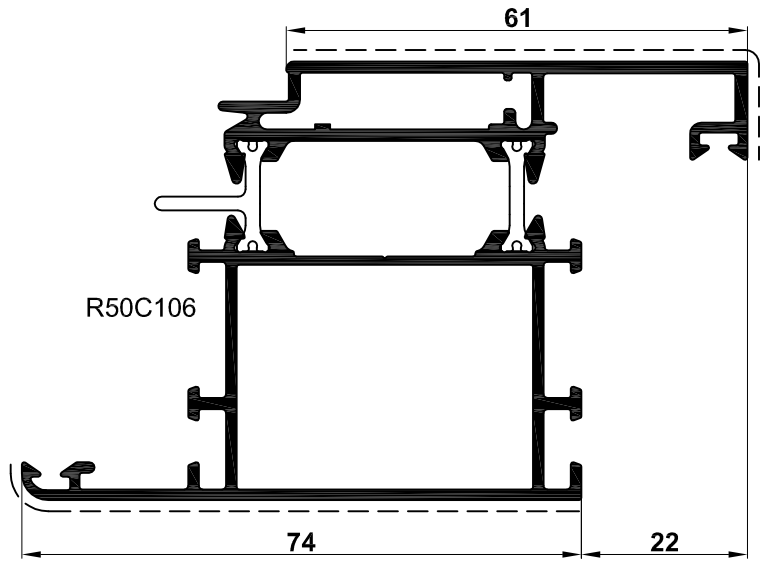
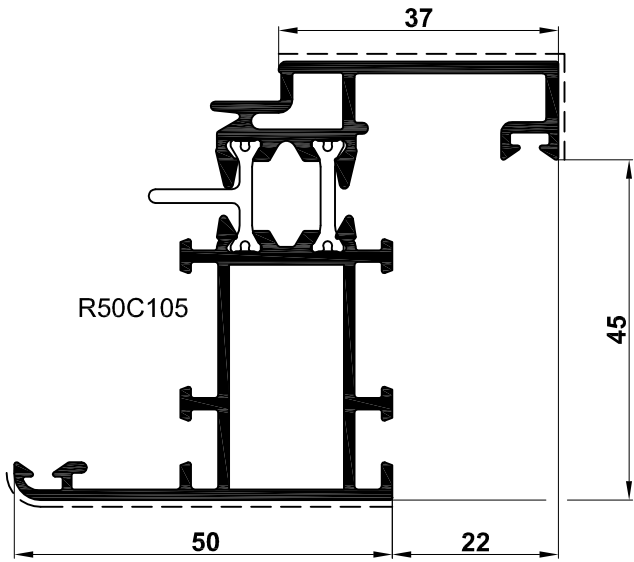

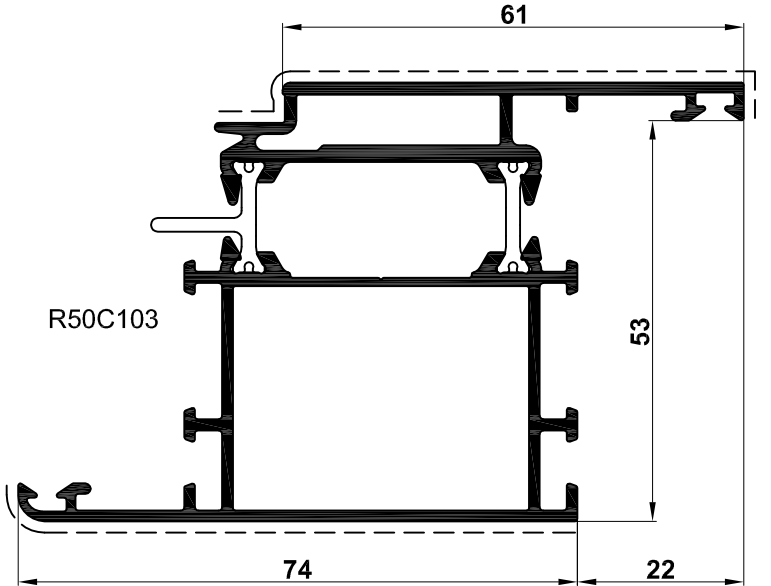
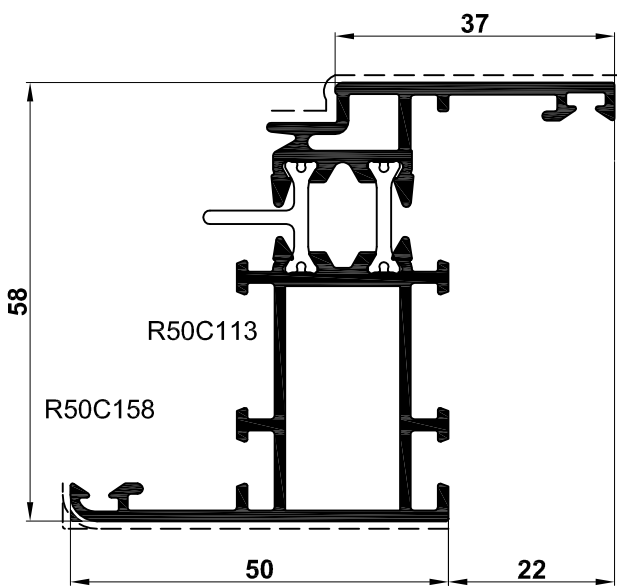
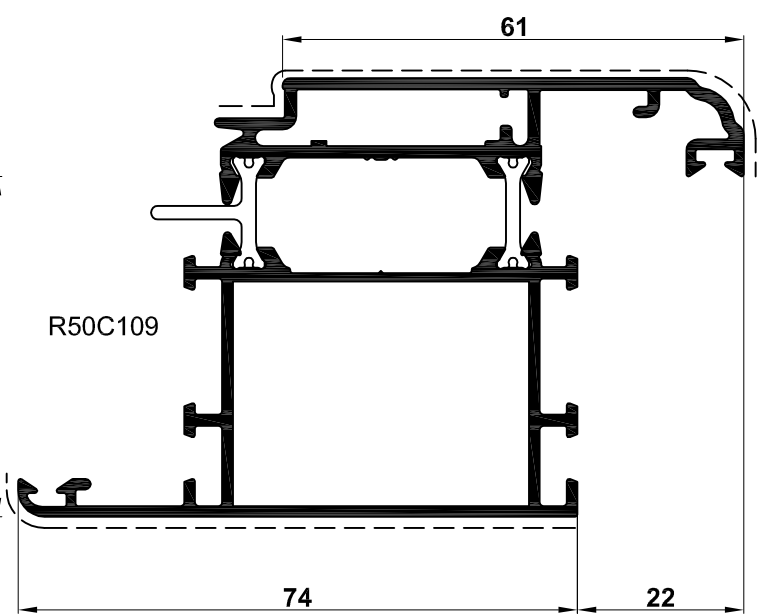
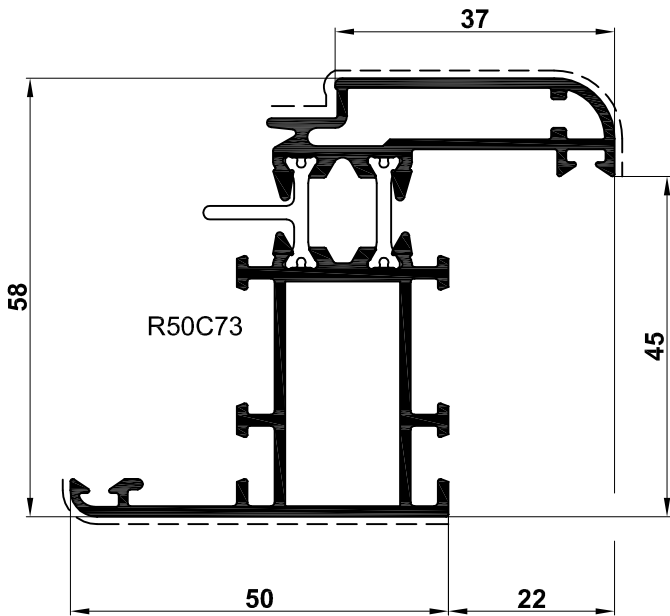
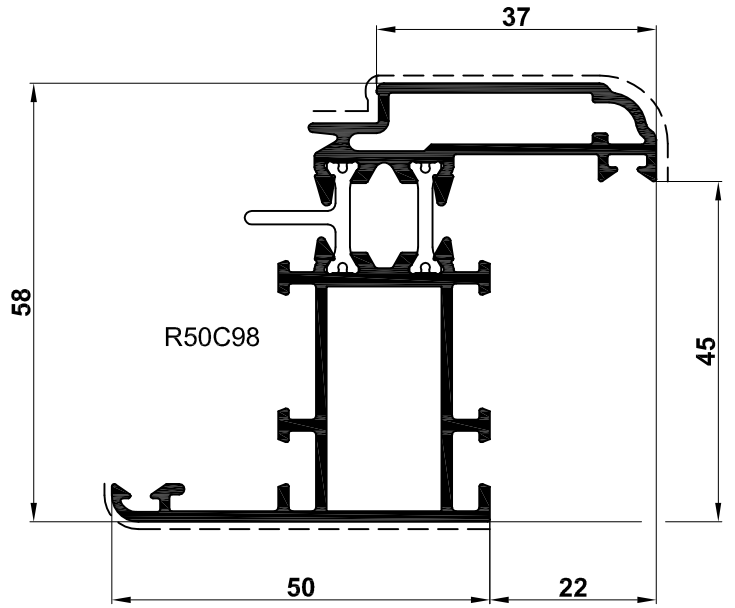
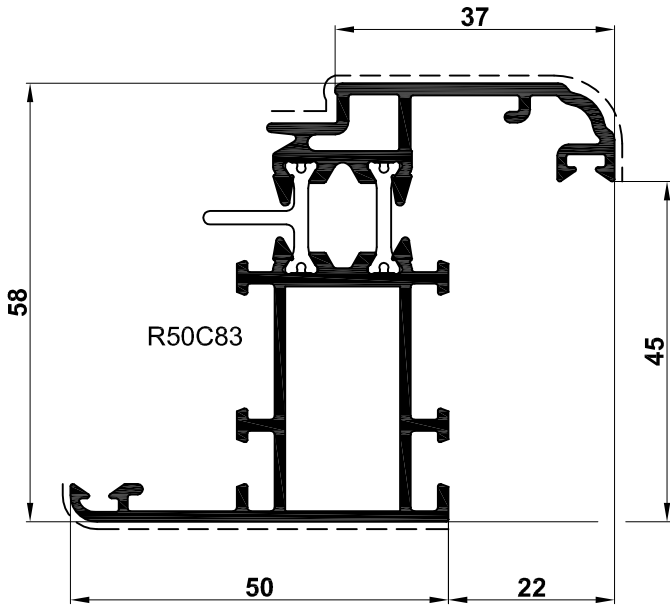

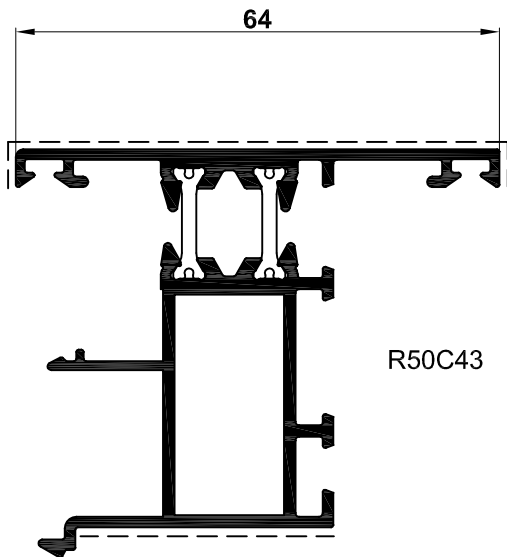

R50C43

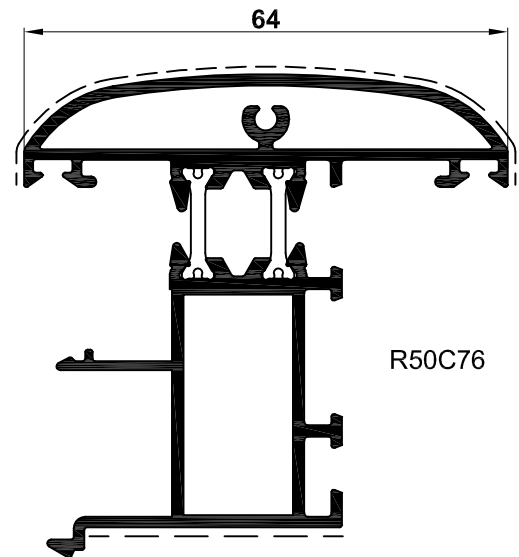

R50C76

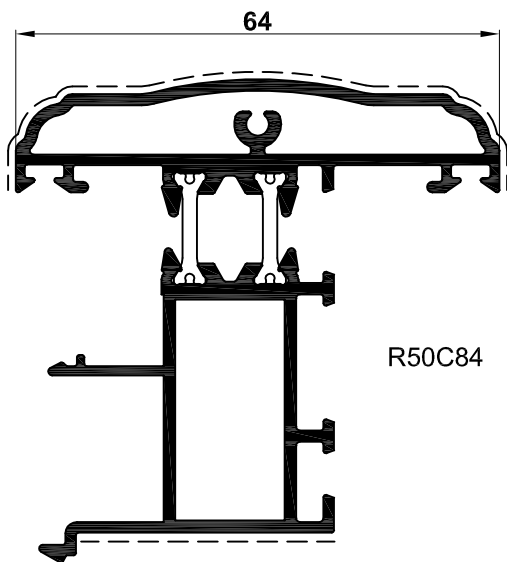

R50C84

INVERSIONE DI BATTUTA
RABBET INVERSION

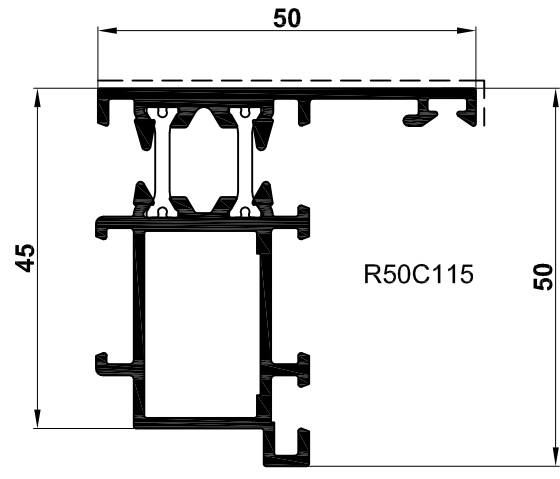

R50C115

RIPORTO CENTRALE - APERTURA ESTERNA
CENTRAL FILLING - OUTWARD OPENING

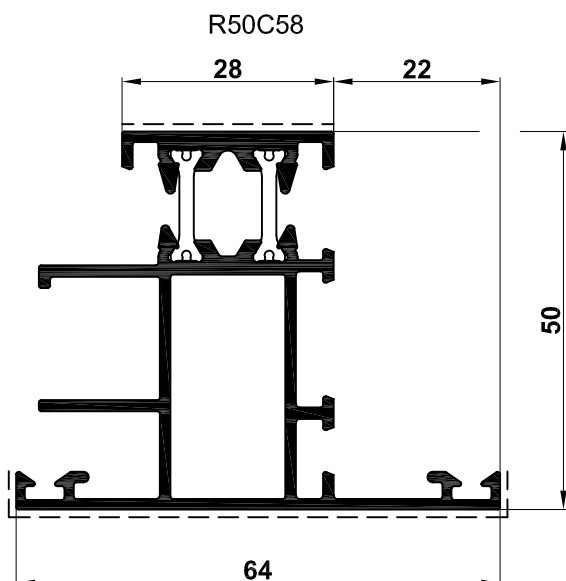

R50C58

ANTA PER APERTURE ESTERNE
WING FOR OUTWARD OPENING

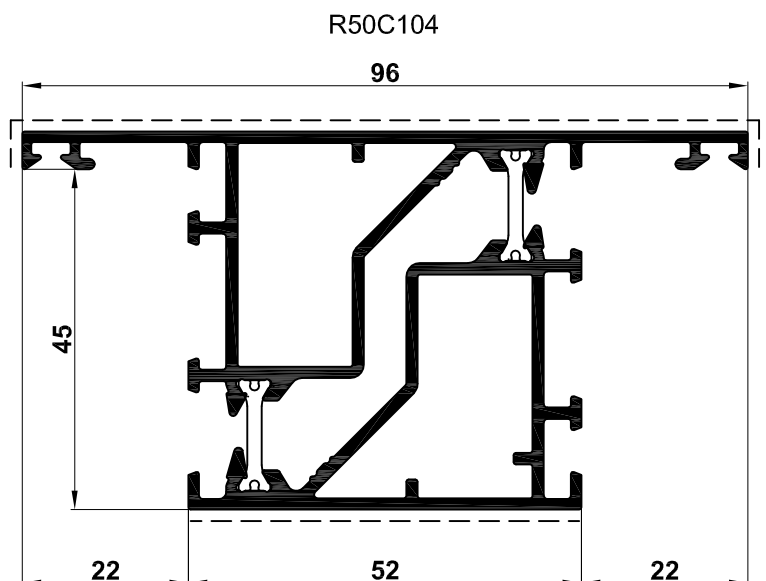

R50C104

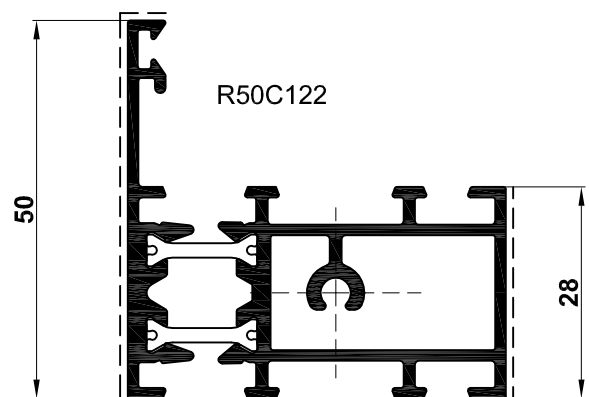
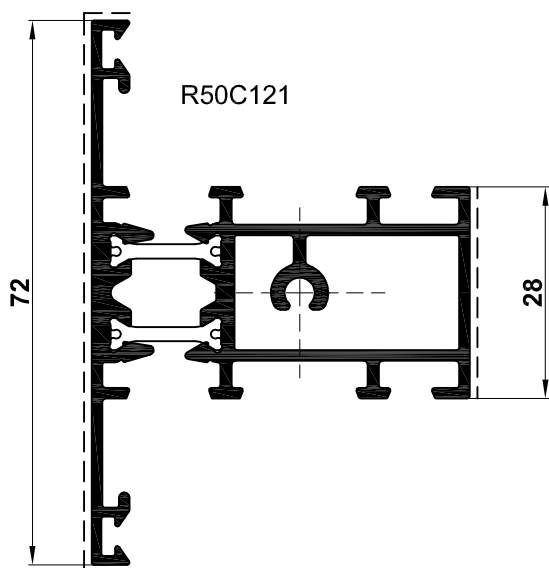
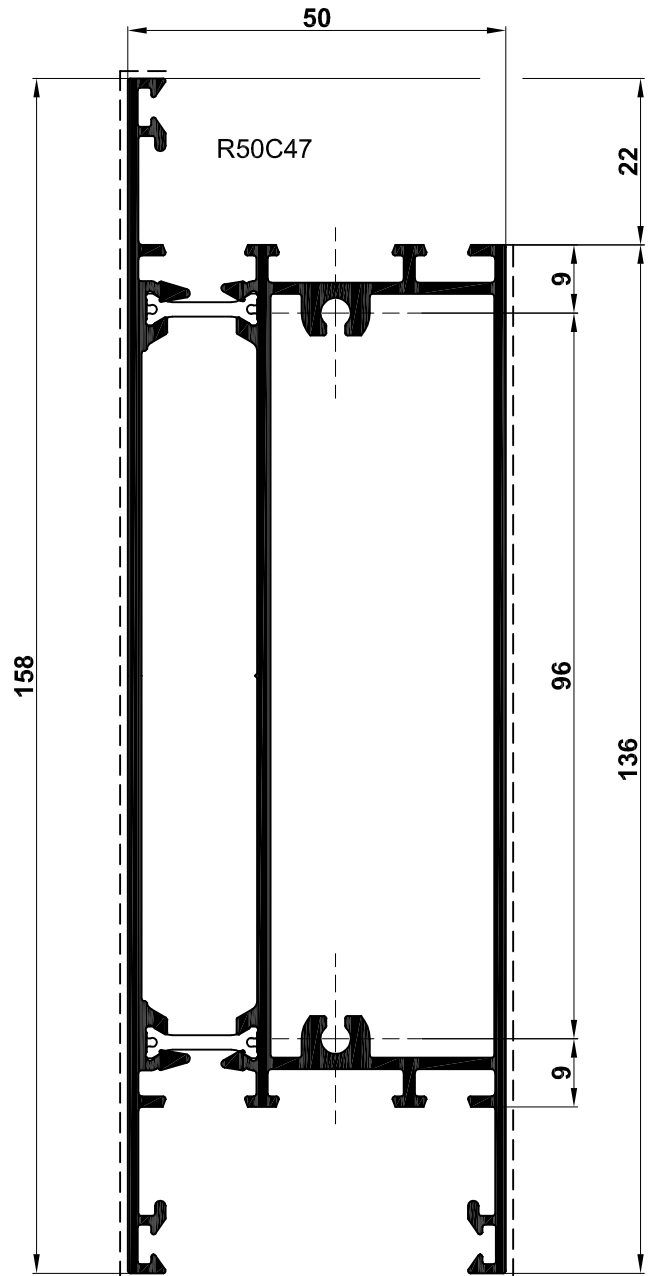
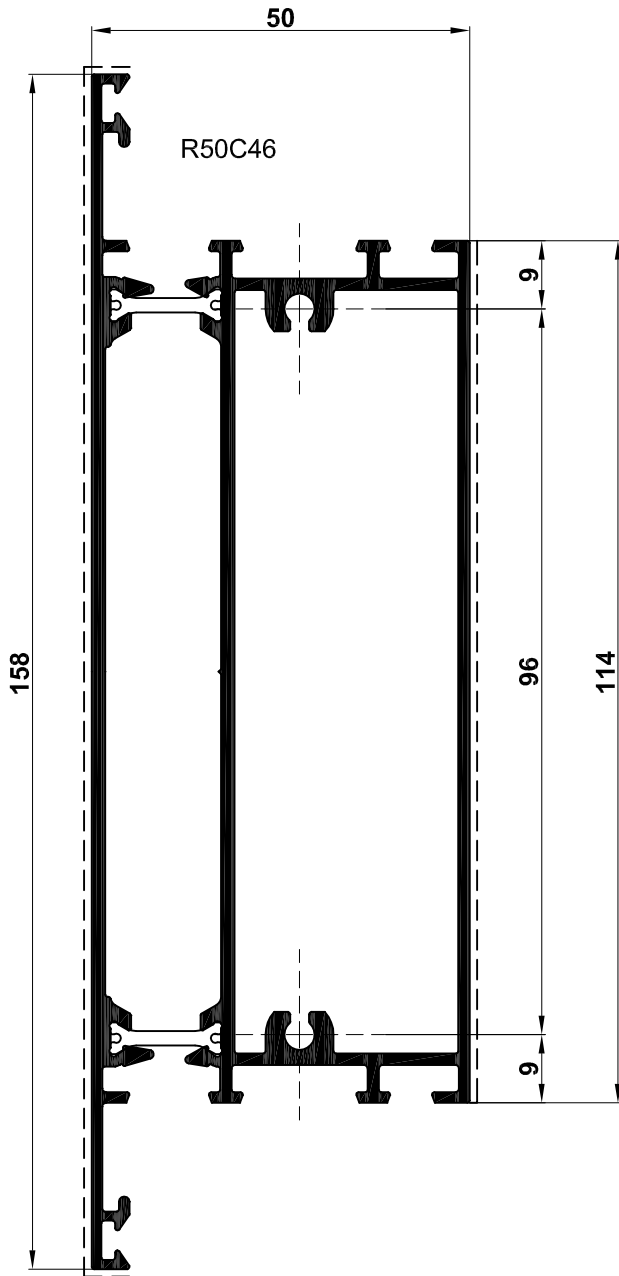

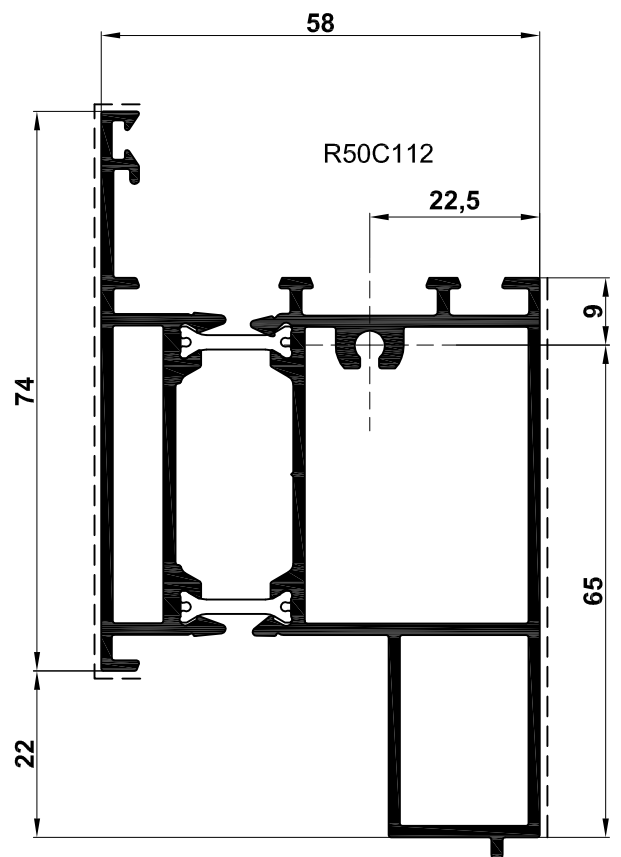
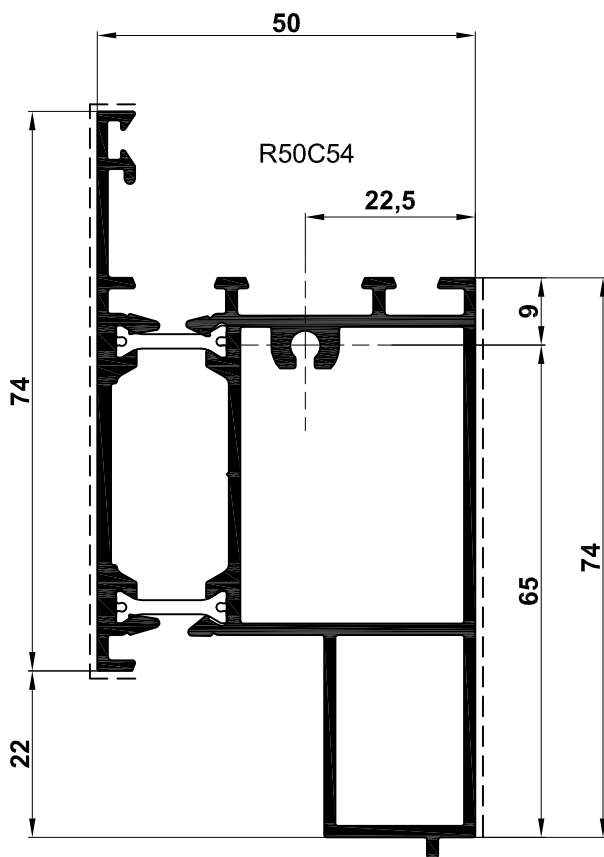
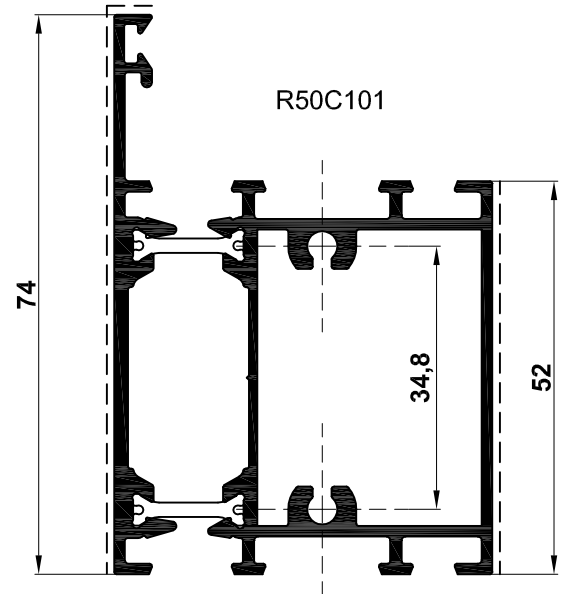
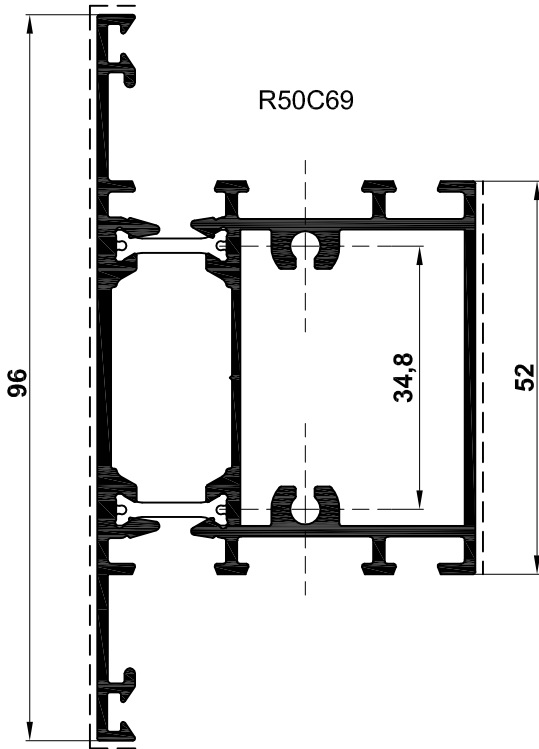

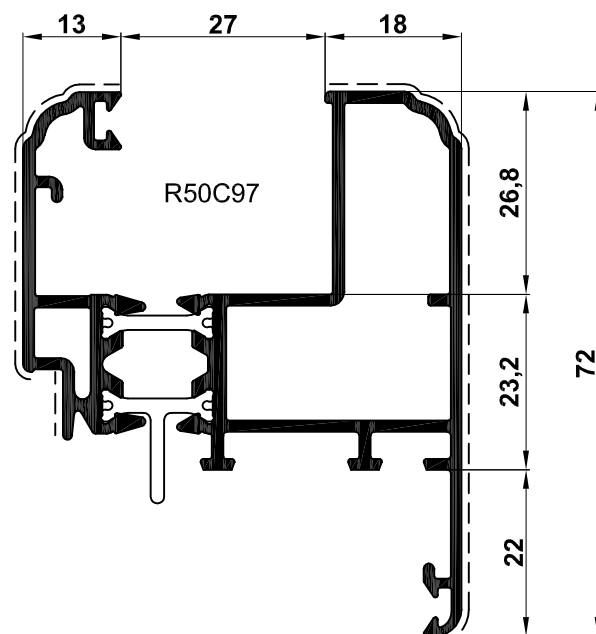
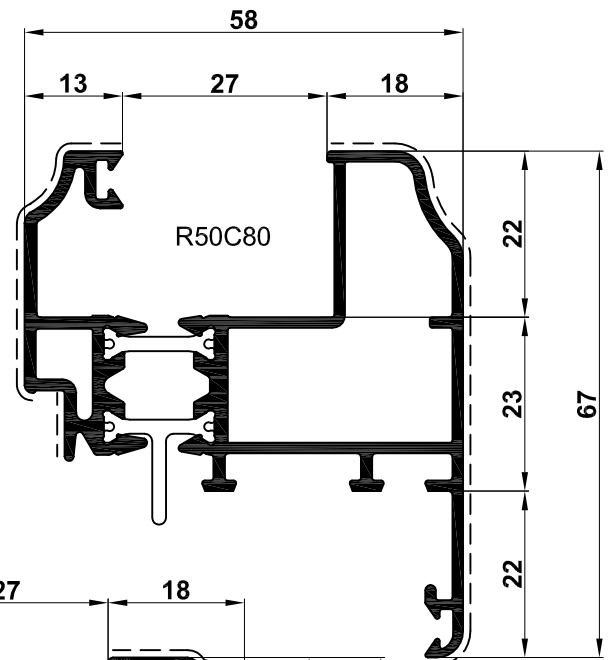
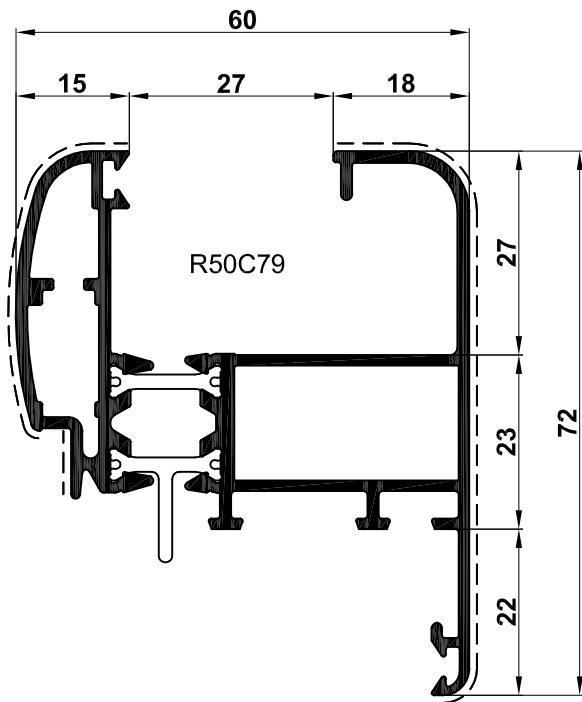
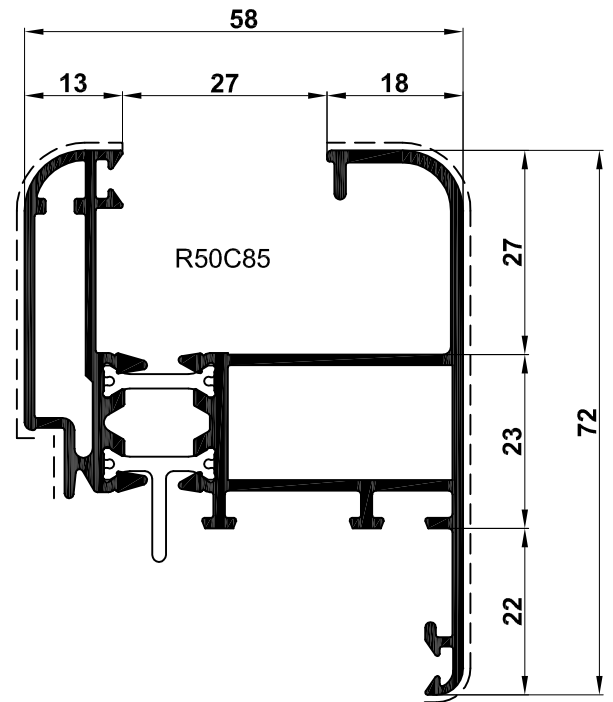
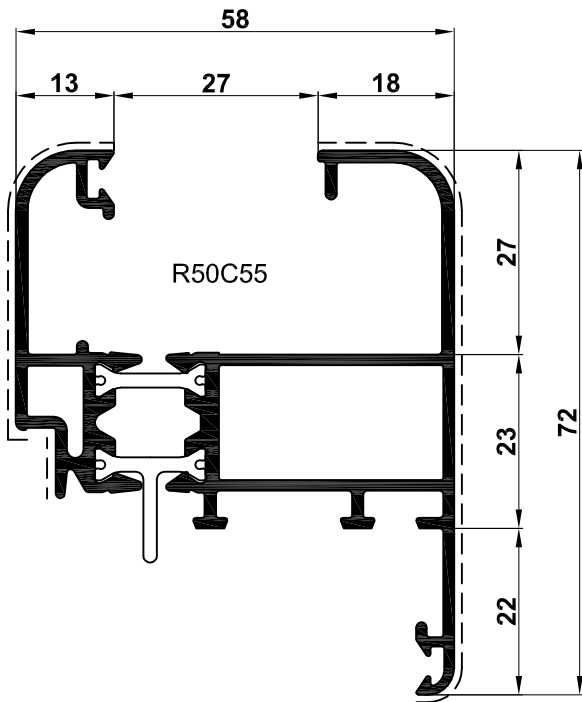

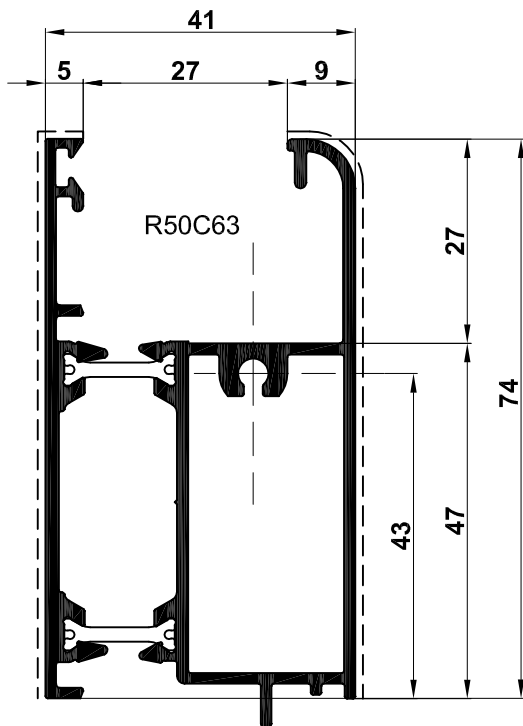
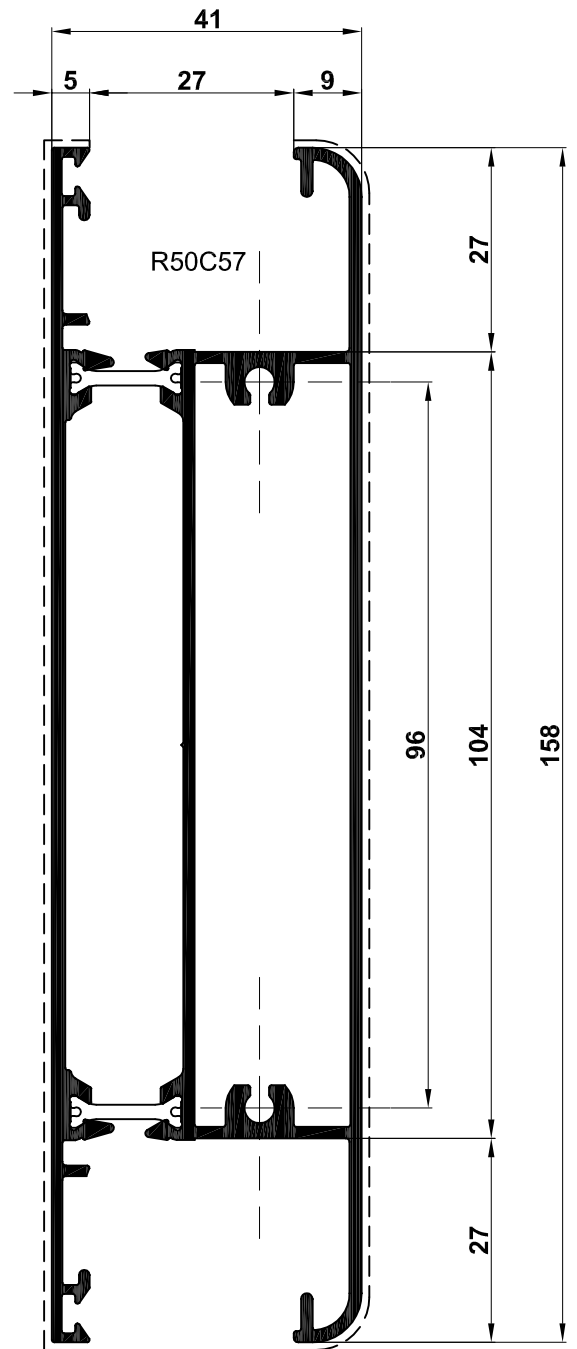
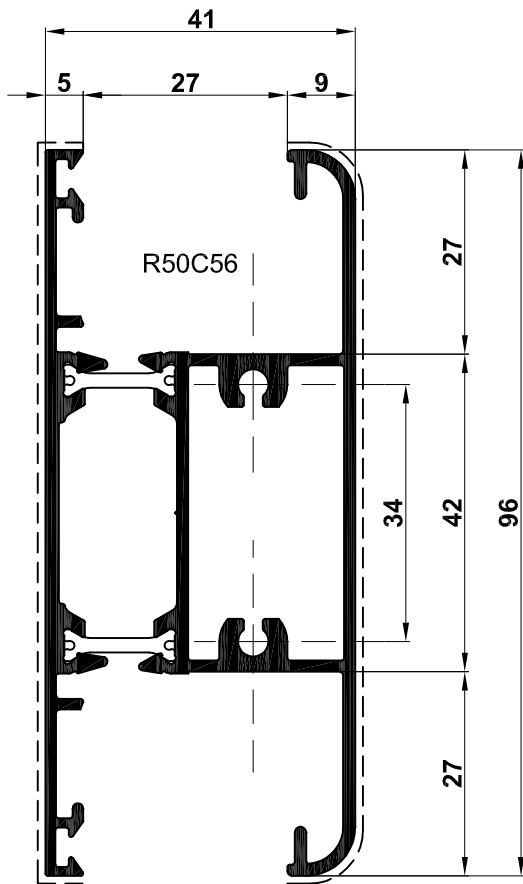

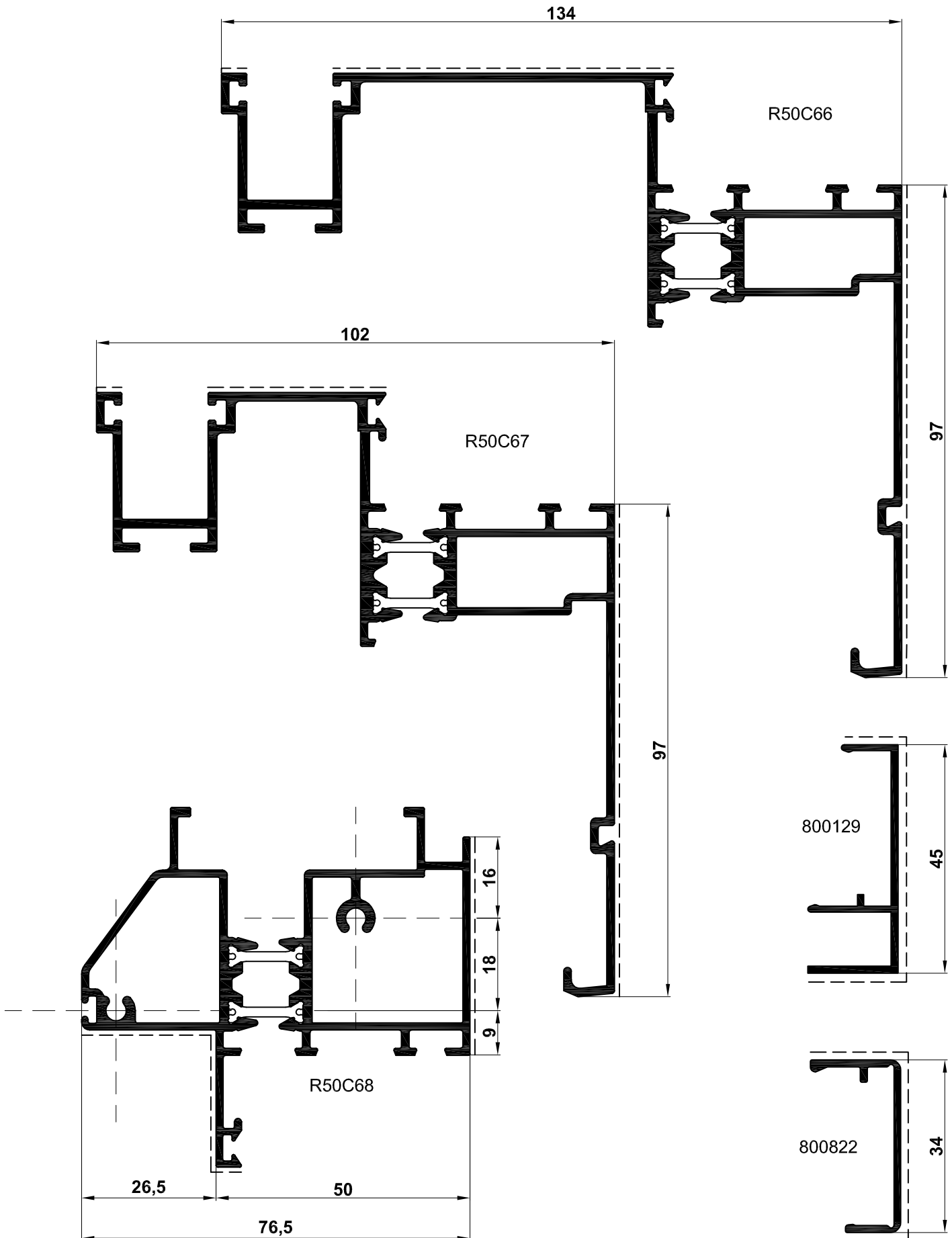

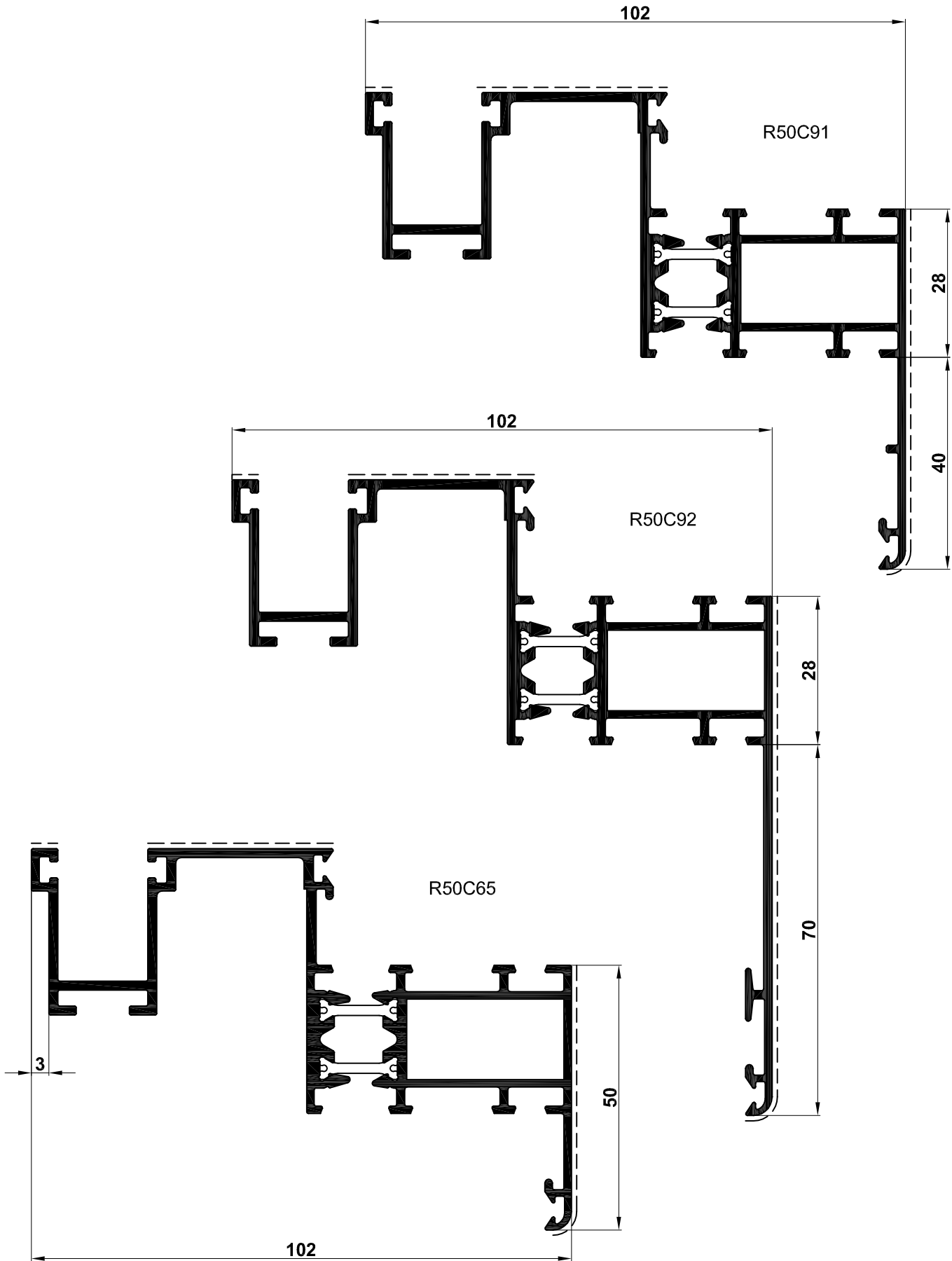

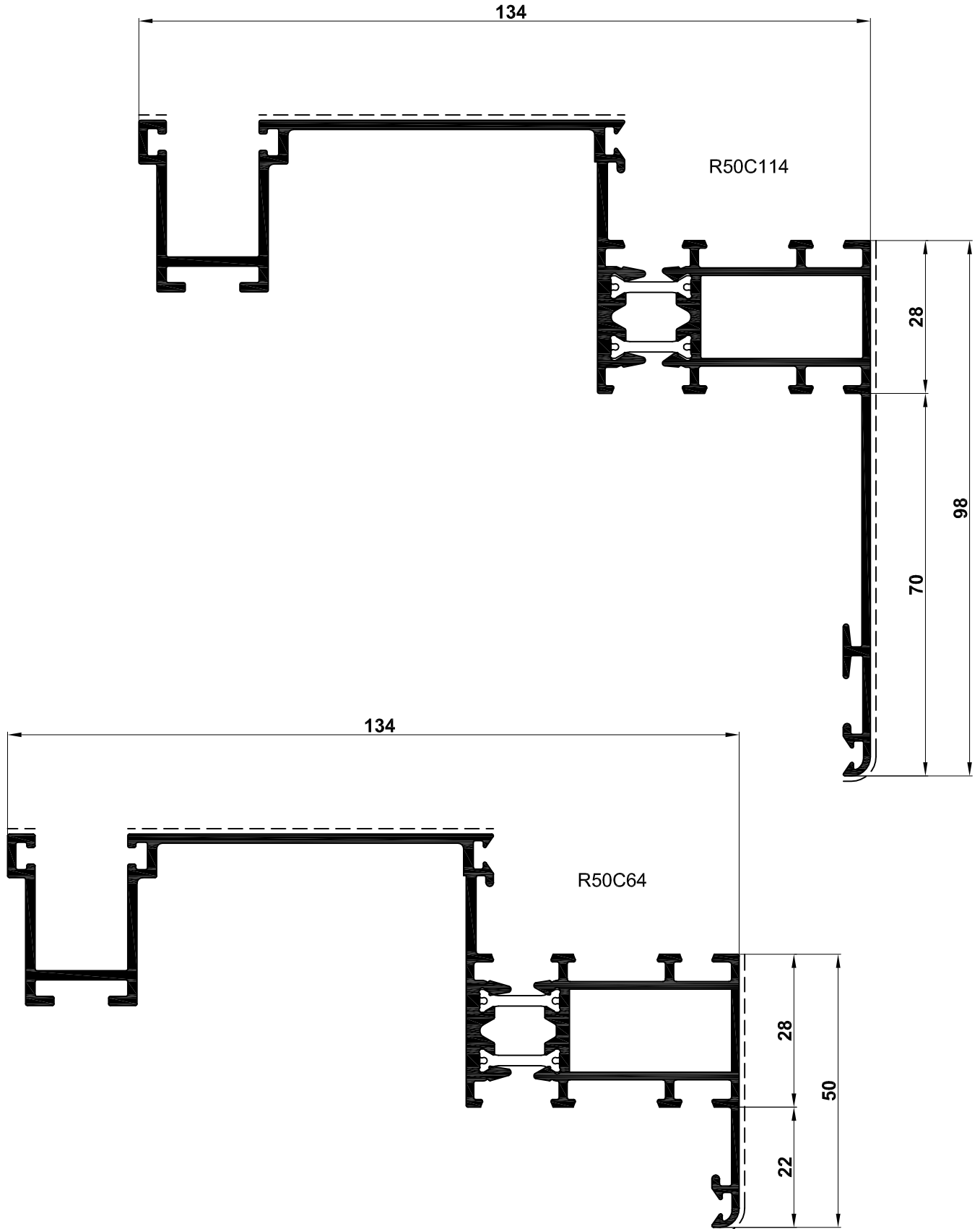

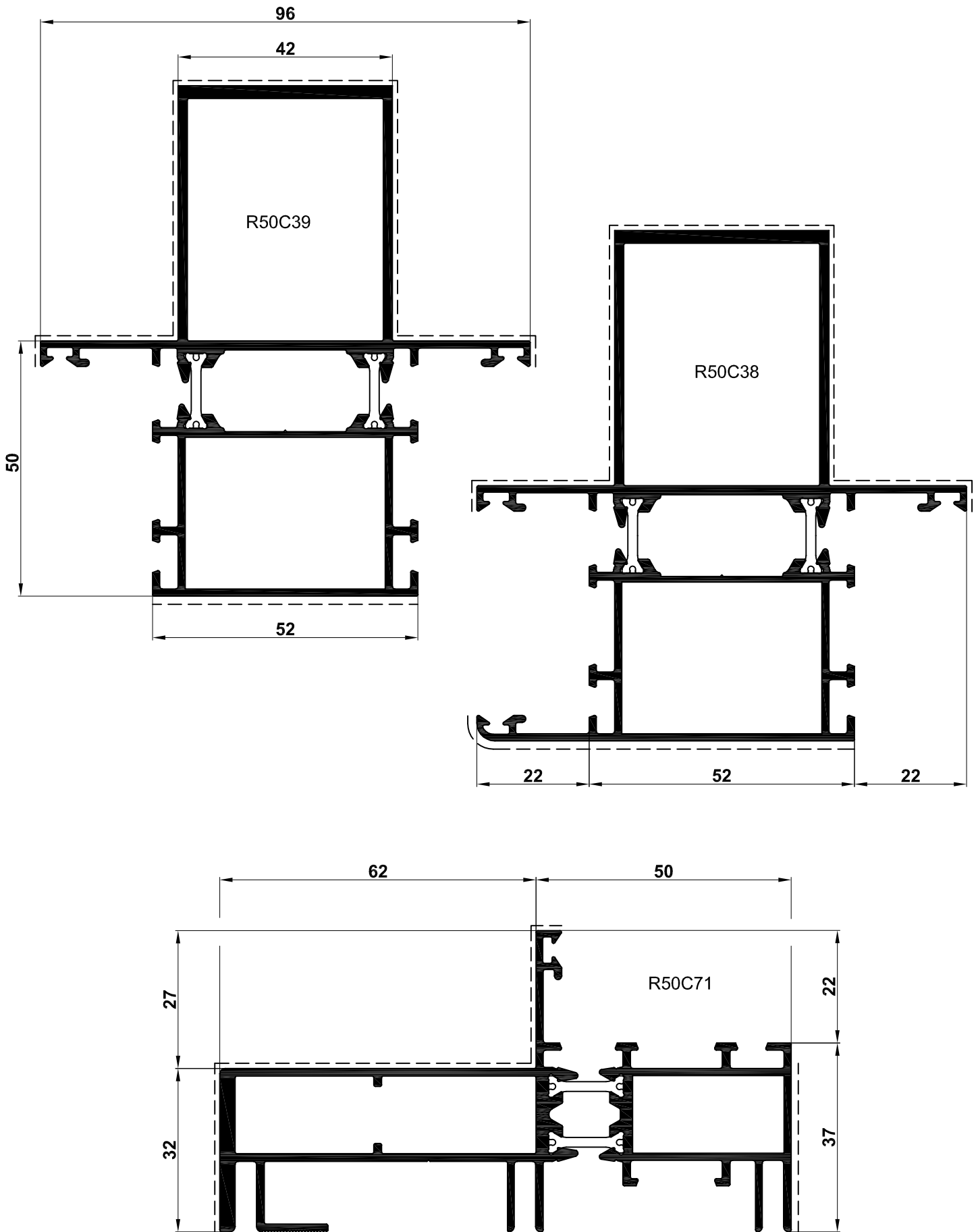

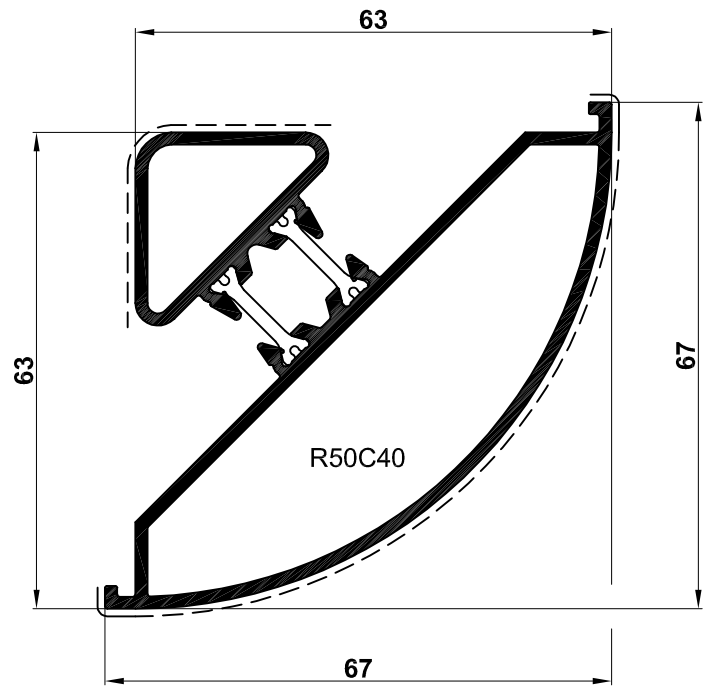
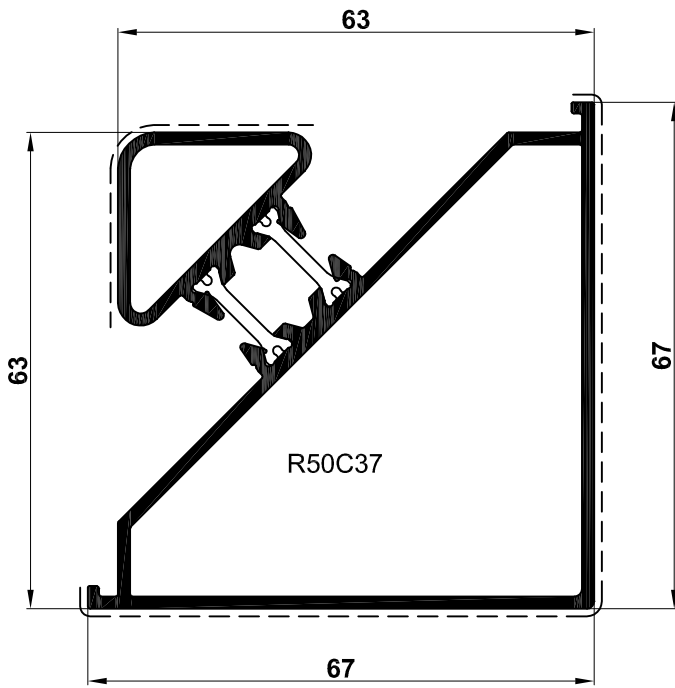

BATTUTA SOGLIA SOTTOZOCCOLO
THRESHOLD RABBET UNDER SKIRTING BOARD

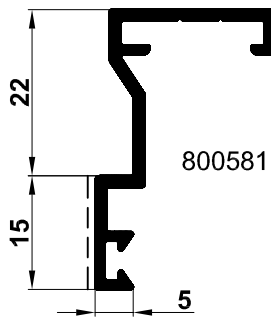

INVERSIONE PER BILICO
INVERSION FOR PIVOTING WINDOW

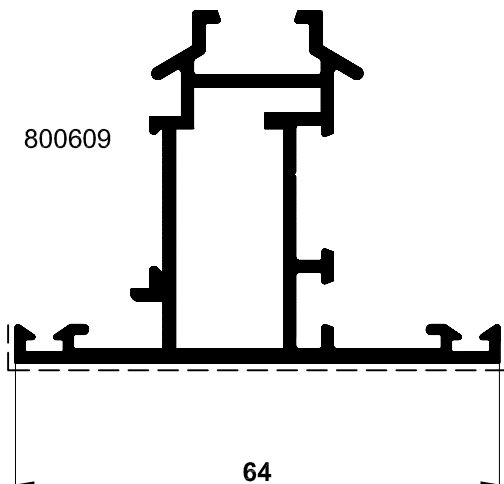

PER ABBINAMENTO CON WIN 65sTT
FOR USE WITH WIN 65sTT

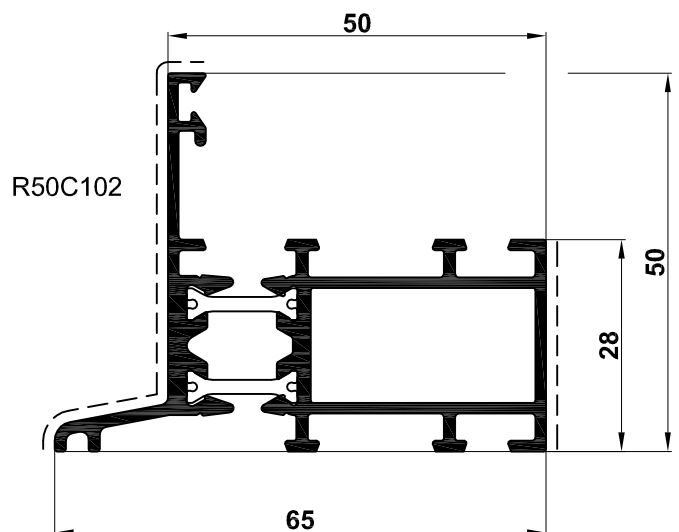

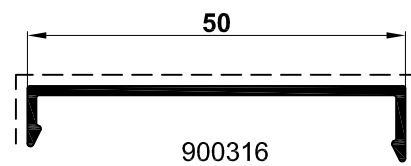
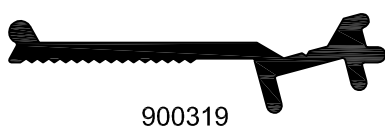
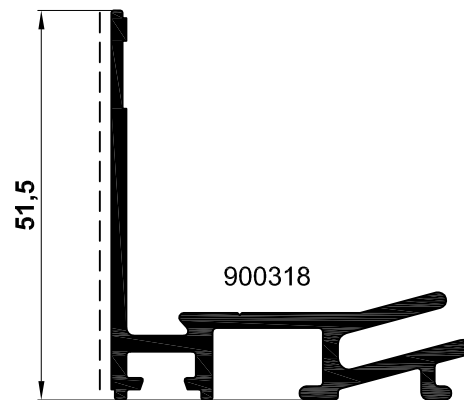
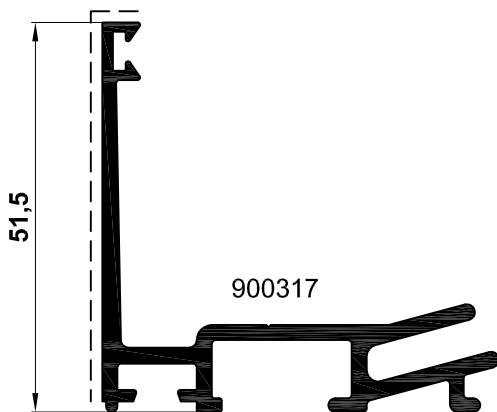
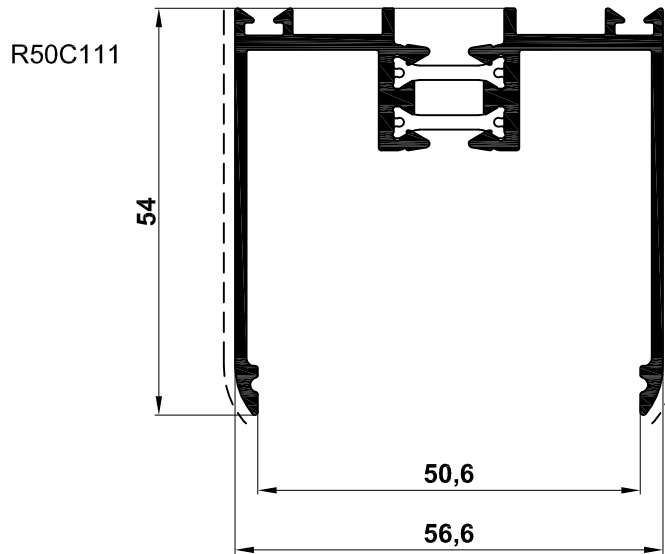

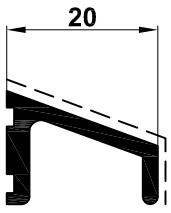

100009

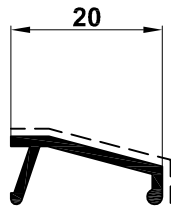

100342

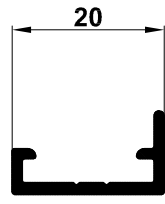

1F14042

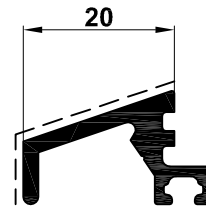

900390

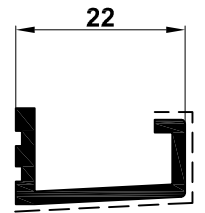

900424

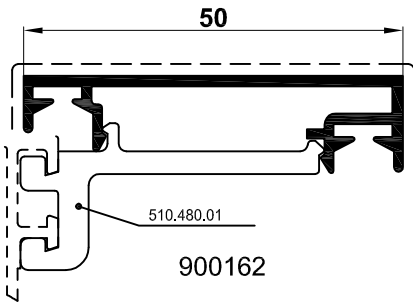

900162

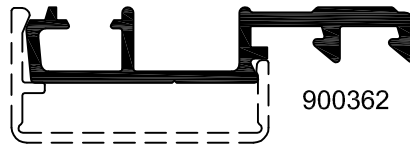

800822

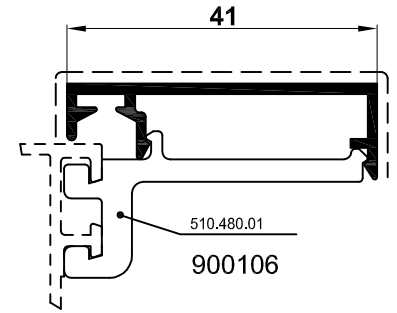

900106

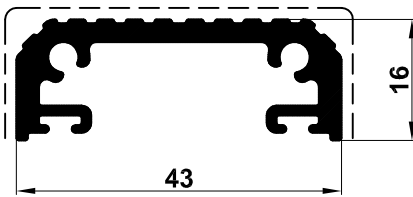

1F14041

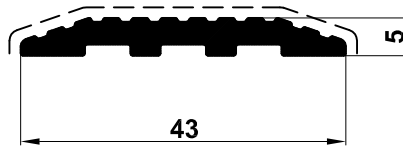

1F14039

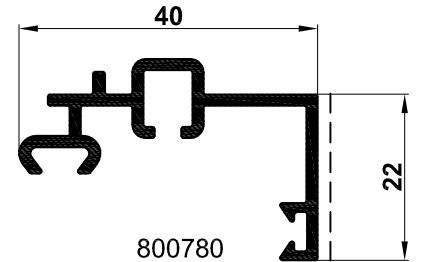

800780

PROFILATI PER SOGLIA
FRAME SECTIONS

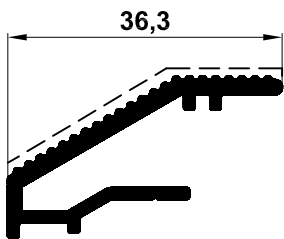

800729

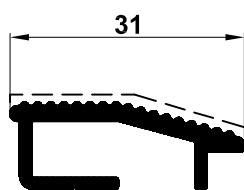

800728

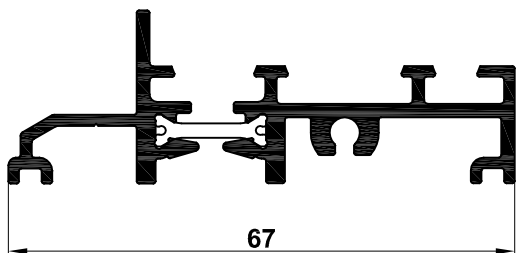

R50C96

ASTA
BAR



900221

Peso Kg/ml 0.162
Perimetro mm 60
Lunghezza Standard Barre = 6500 mm
Standard length = 6500 mm

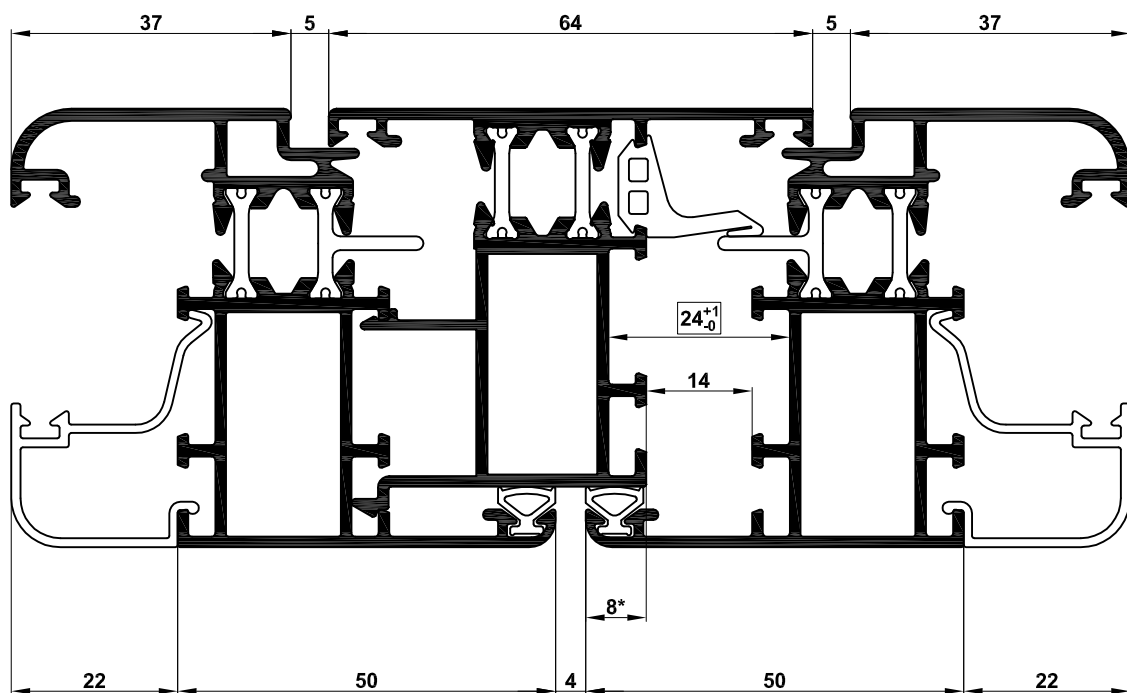
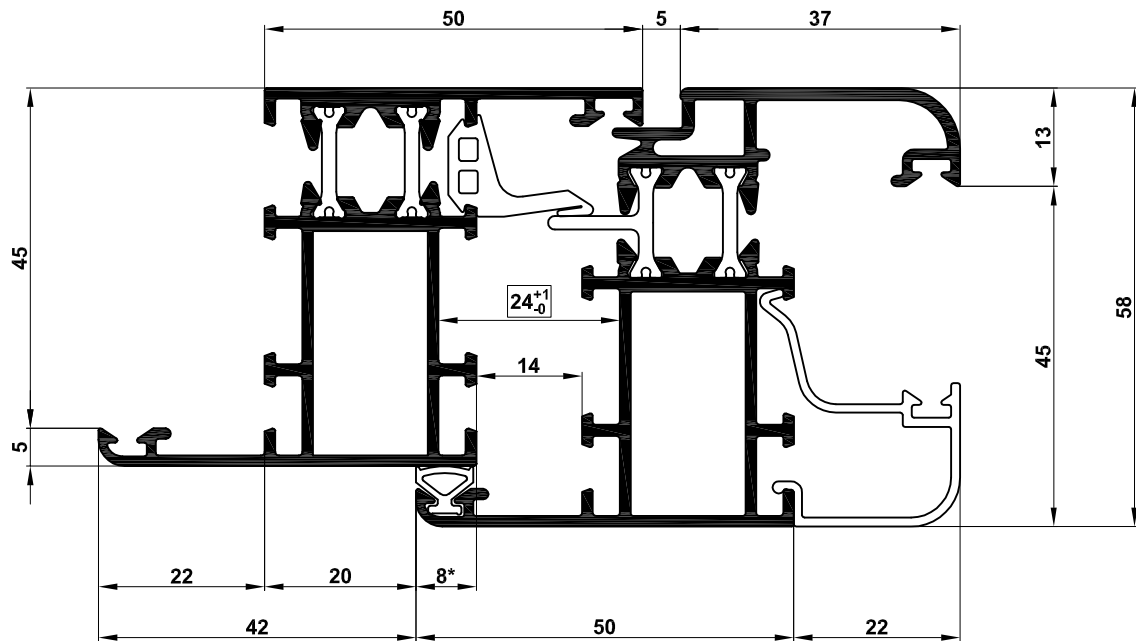

Dimensione Minima Larghezza Anta 400mm

Minimum wing width 400mm

Nel caso si debbano realizzare ante aventi dimensioni ridotte (vedi nota riportata) si consiglia di diminuire la quota di battuta da 8 mm a 7,5 mm

In case you need to realize small wings (see note). We suggest to decrease the closure dimension from 8mm to 7,5mm

N.B.:

- Le dimensioni indicate sono state ottenute considerando le quote teoriche.

N.B.:

-The dimensions indicated, are obtained considering theoretical values.

- Sezioni tipiche finestra, porta a battente e anta ribalta.
 Typical sections of window, door and tilt and turn.

- Per distinte di taglio e inserimento accessori, tenere presente questo schema
 Take this diagram into consideration for cut and accessories

* Per anta ribalta "Rbalta 150", considerare 7,5 mm
 For "Rbalta 150" tilt and turn, have to consider 7,5 mm

The sections, accessories and weatherstrips in this catalogue belong to Sapa as sole patentee.

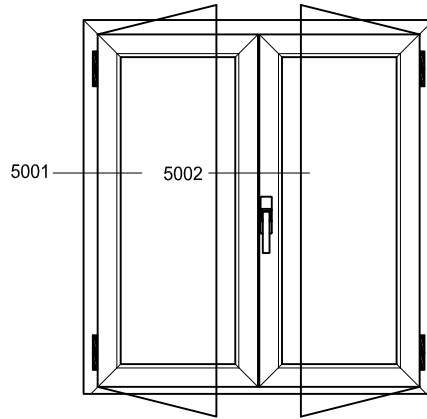

(*) Negli angoli a 45° le squadrette inserite nel tubolare esterno devono essere sempre incollate e cianfrinate. Cianfrinatura eseguibile anche con attrezzatura manuale Cod. M.2001.OO
In the 45° corners, the corner joints in the external tubular section, must always be glued and caulked. Caulking may also be carried out by hand with equipment Art.M.2001.OO

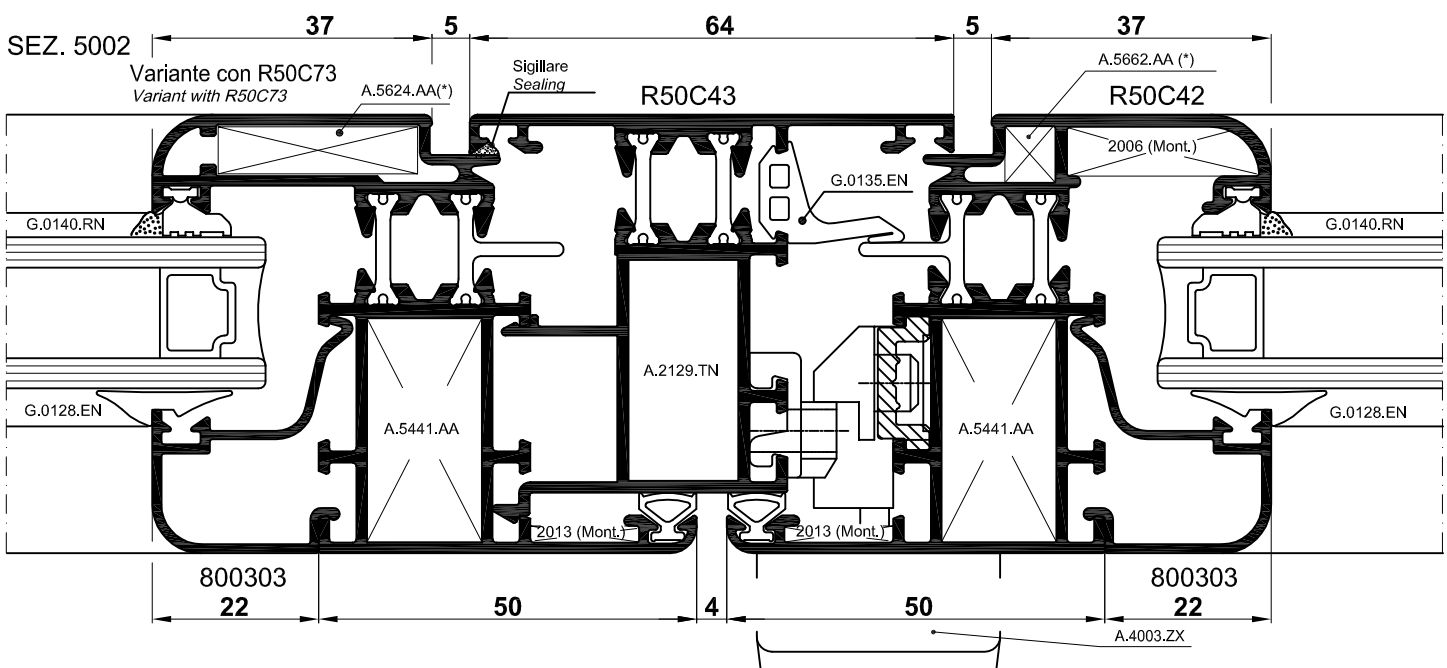
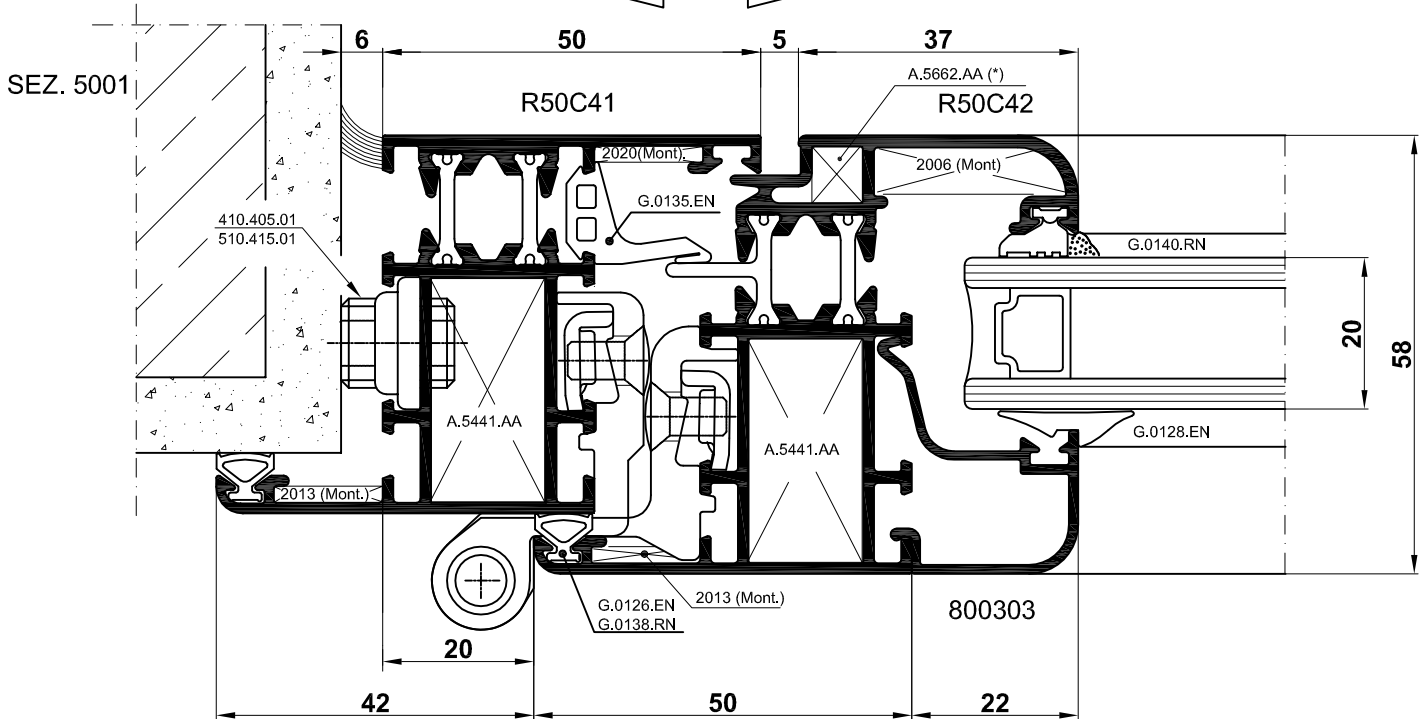

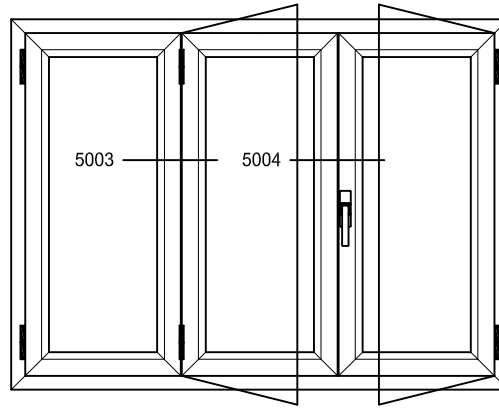

(*) Negli angoli a 45° le squadrette inserite nel tubolare esterno devono essere sempre incollate e cianfrinate.
 Cianfrinatura eseguibile anche con attrezzatura manuale Cod. M.2001.OO
In the 45° corners, the corner joints in the external tubular section, must always be glued and caulked. Caulking may also be carried out by hand with equipment Art.M.2001.OO

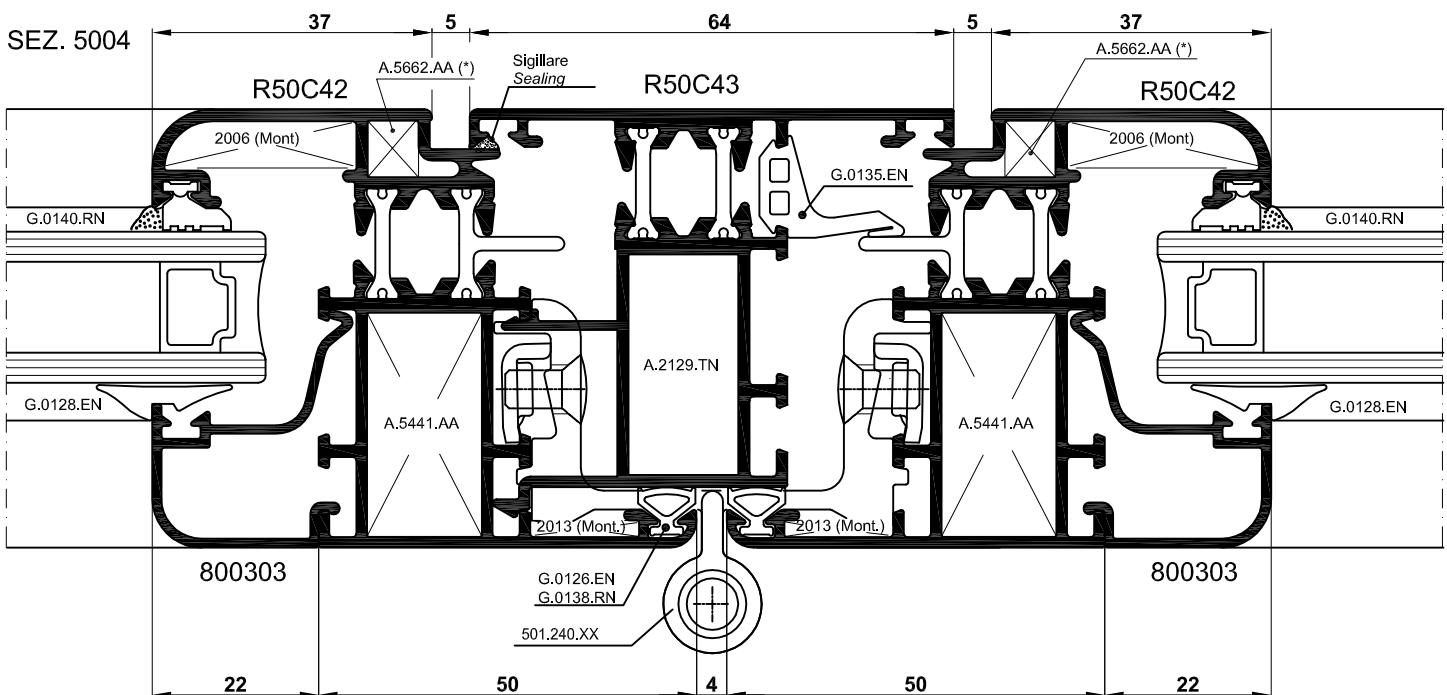
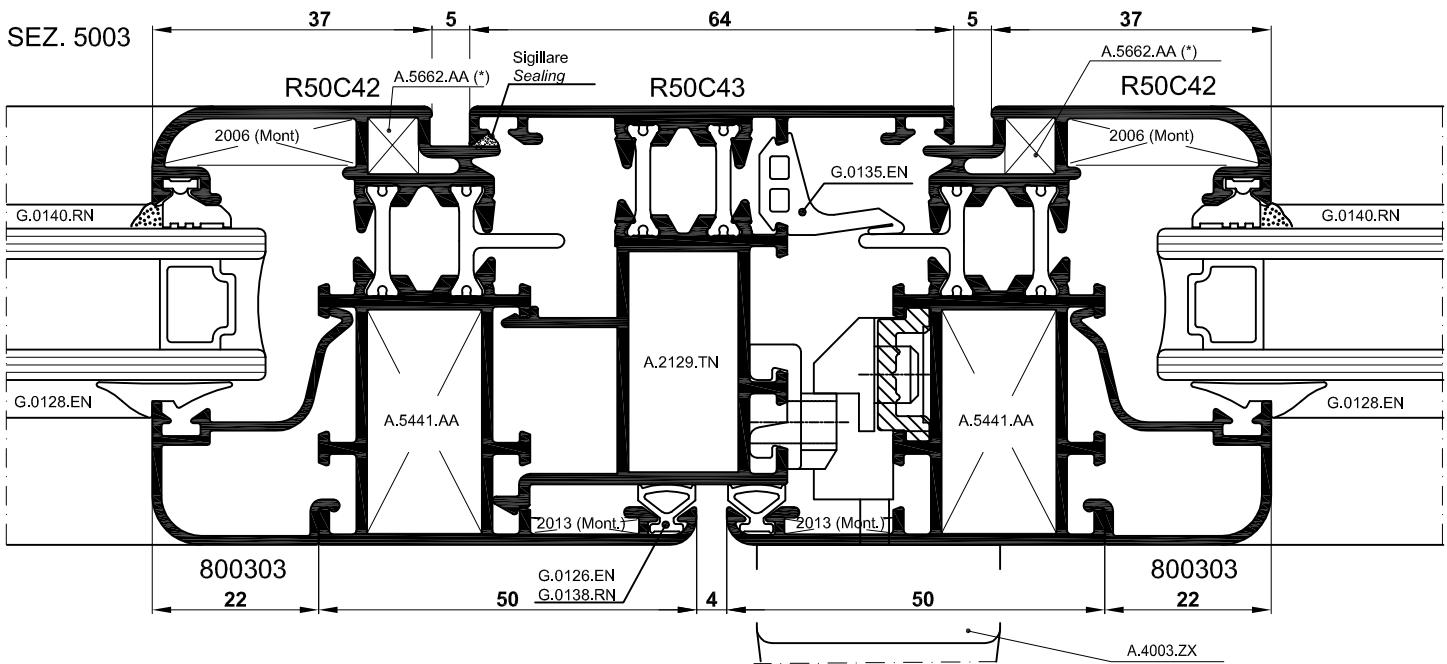

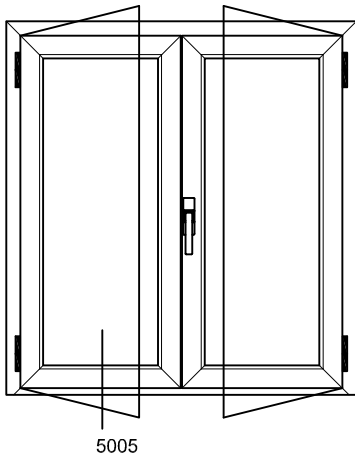

5005

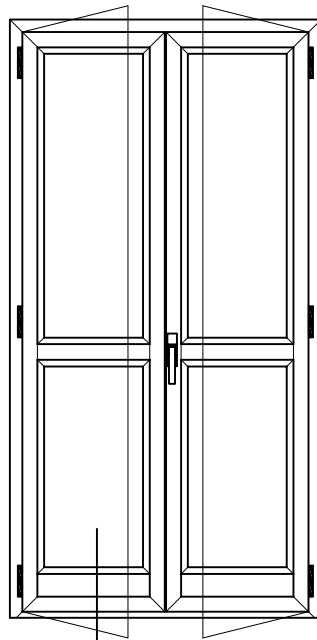

5006

(*) Negli angoli a 45° le squadrette inserite nel tubolare esterno devono essere sempre incollate e cianfrinate.
Cianfrinatura eseguibile anche con attrezzatura manuale Cod. M.2001.OO
In the 45° corners, the corner joints in the external tubular section, must always be glued and caulked.
Caulking may also be carried out by hand with equipment Art.M.2001.OO

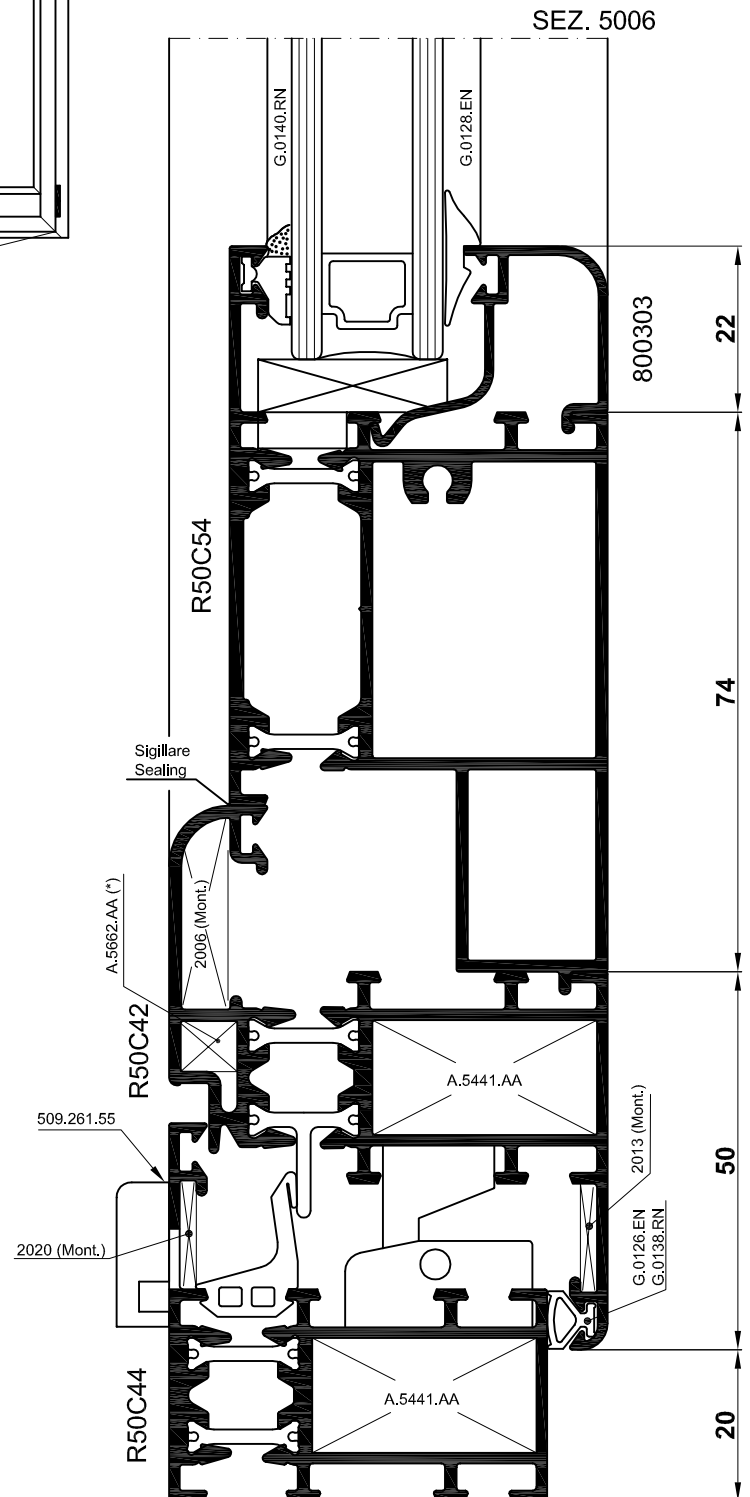
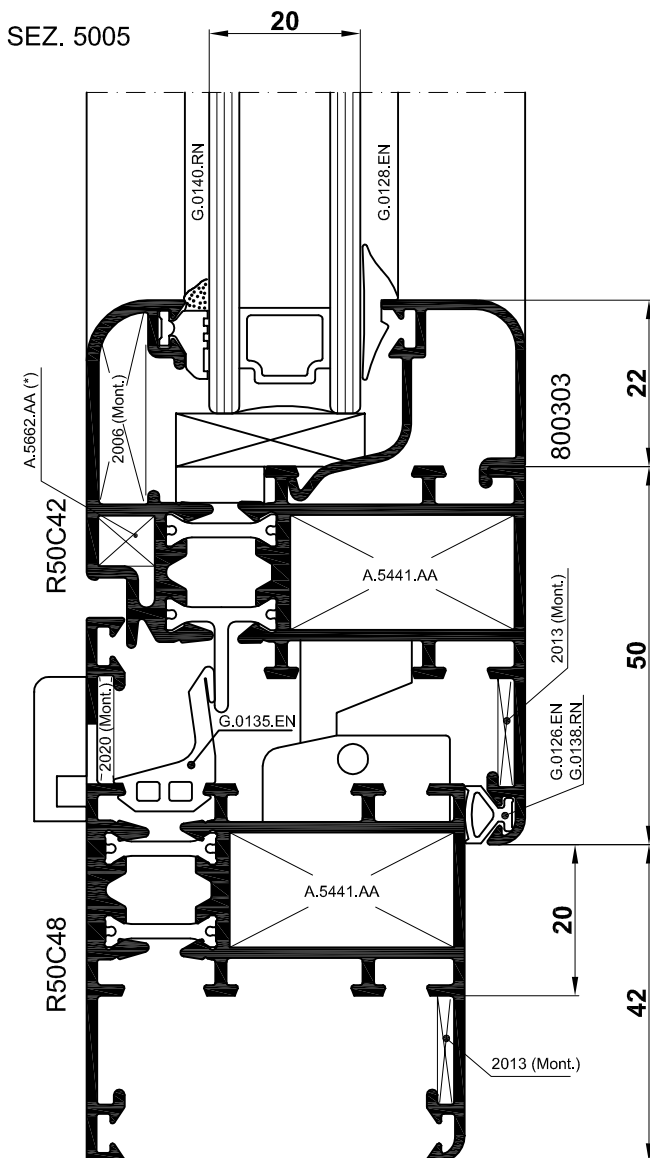

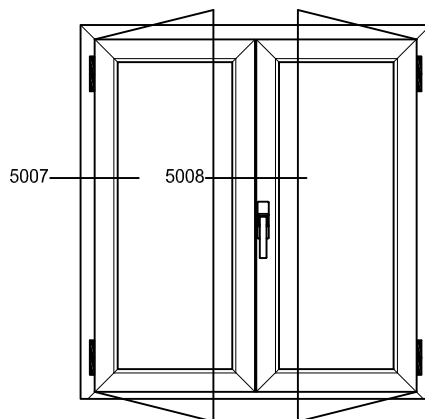

(*) Negli angoli a 45° le squadrette inserite nel tubolare esterno devono essere sempre incollate e cianfrinate. Cianfrinatura eseguibile anche con attrezzatura manuale Cod. M.2001.OO
In the 45° corners, the corner joints in the external tubular section, must always be glued and caulked. Caulking may also be carried out by hand with equipment Art.M.2001.OO

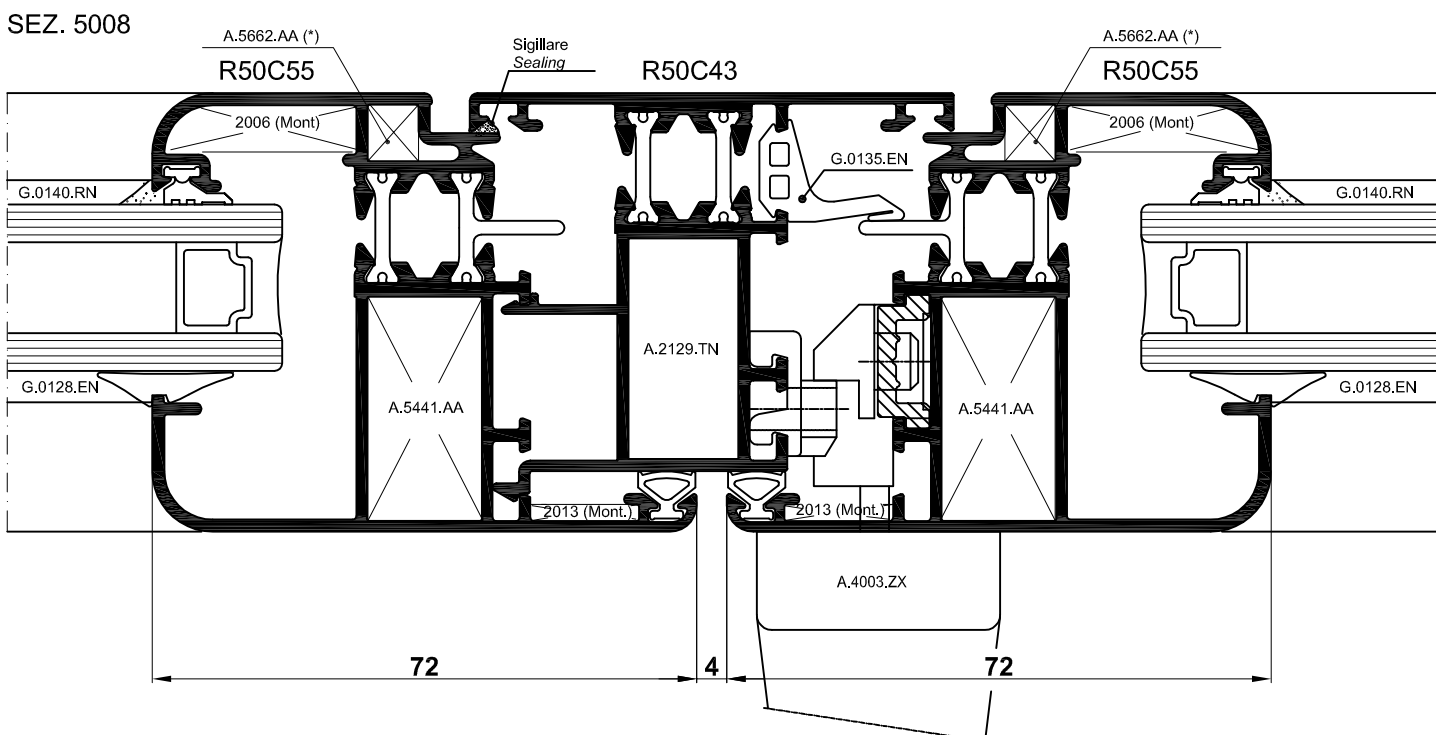
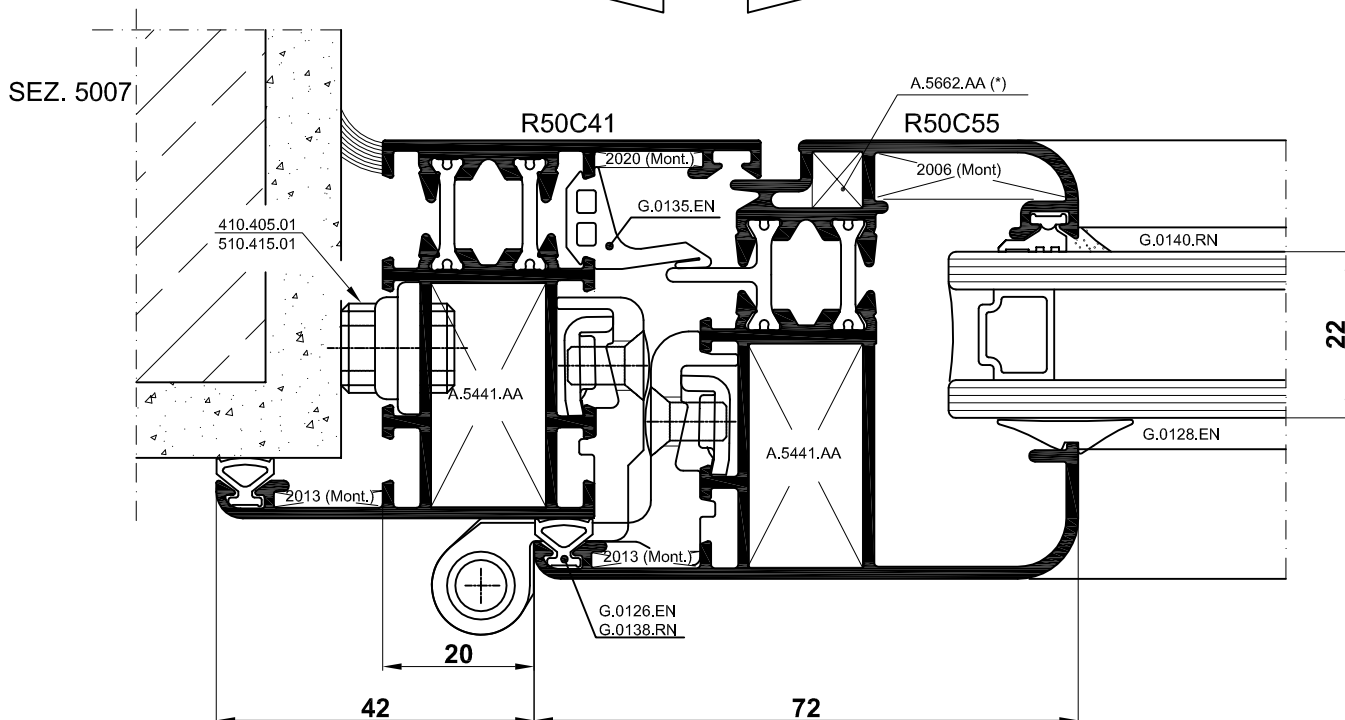

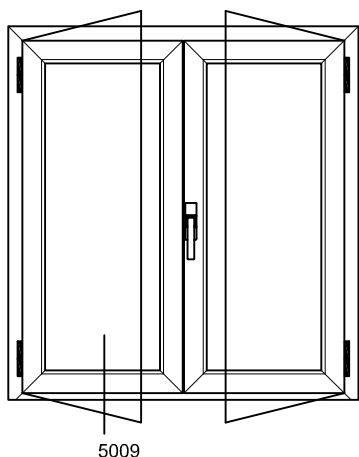

5009

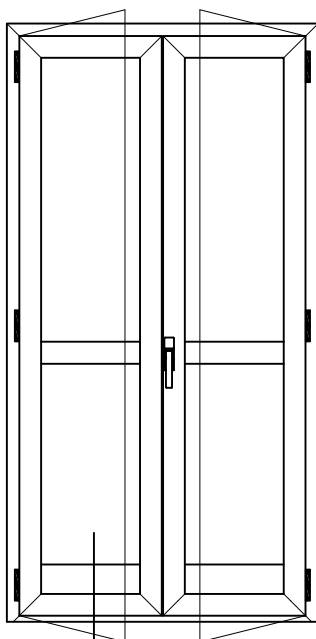

5010

(*) Negli angoli a 45° le squadrette inserite nel tubolare esterno devono essere sempre incollate e cianfrinate. Cianfrinatura eseguibile anche con attrezzatura manuale Cod. M.2001.OO
In the 45° corners, the corner joints in the external tubular section, must always be glued and caulked. Caulking may also be carried out by hand with equipment Art.M.2001.OO

SEZ. 5009

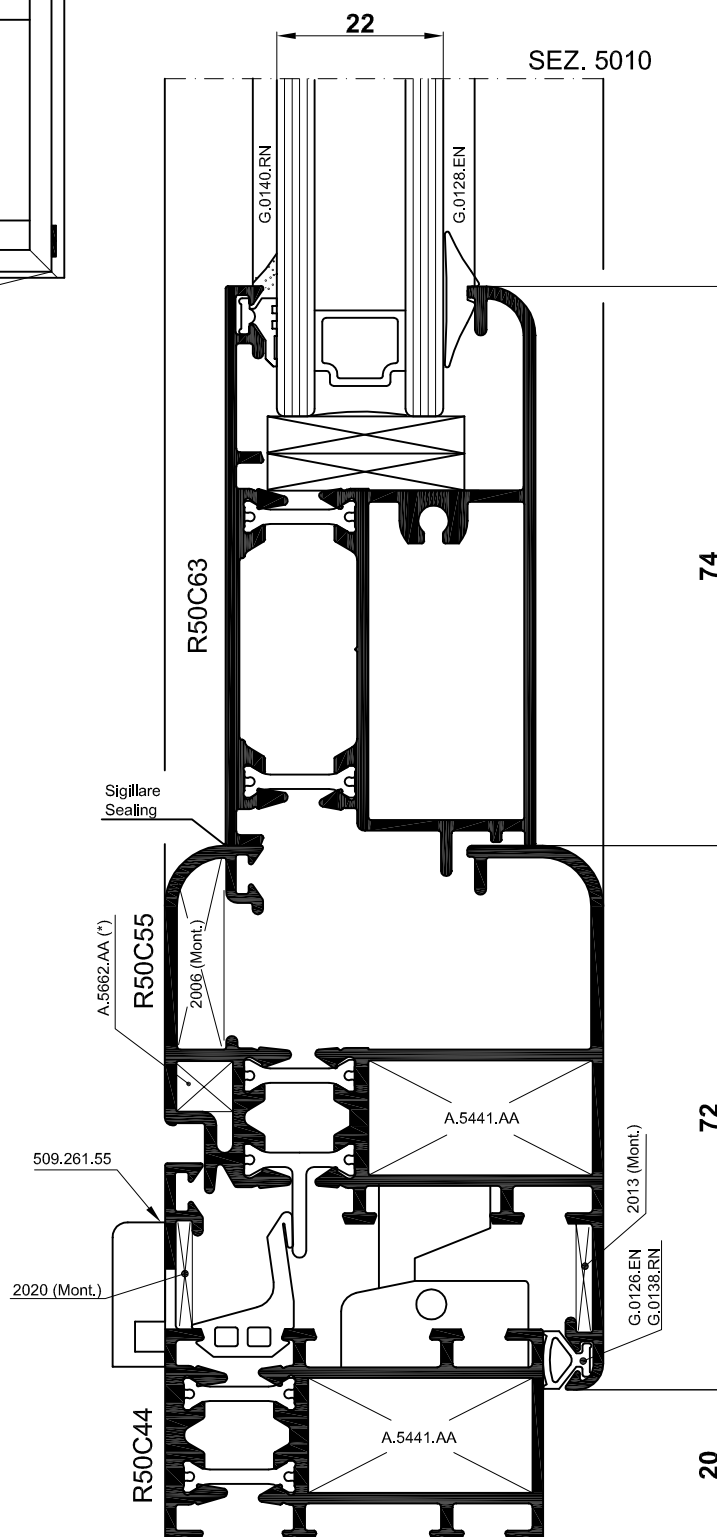
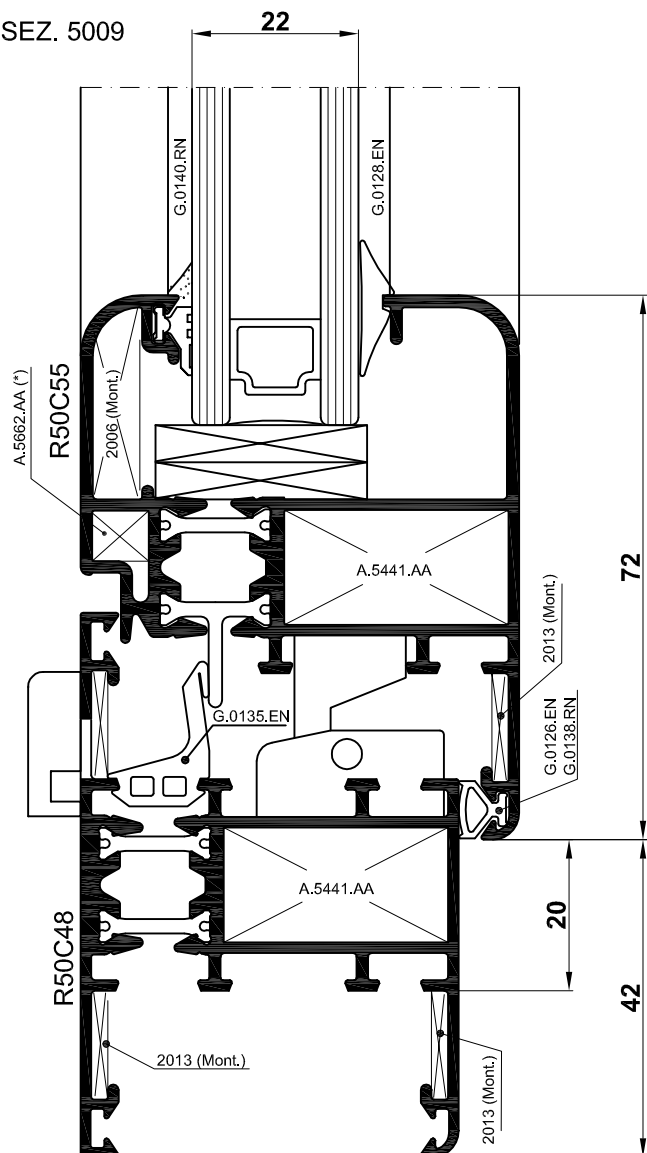

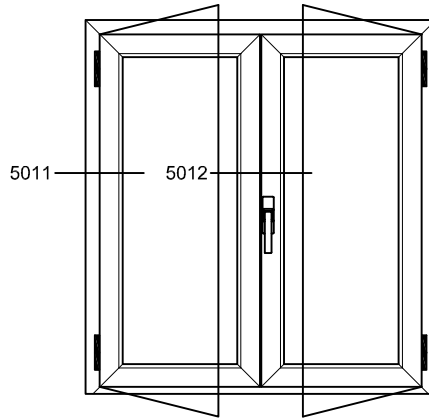

(*) Negli angoli a 45° le squadrette inserite nel tubolare esterno devono essere sempre incollate e cianfrinate. Cianfrinatura eseguibile anche con attrezzatura manuale Cod. M.2001.OO
In the 45° corners, the corner joints in the external tubular section, must always be glued and caulked. Caulking may also be carried out by hand with equipment Art.M.2001.OO

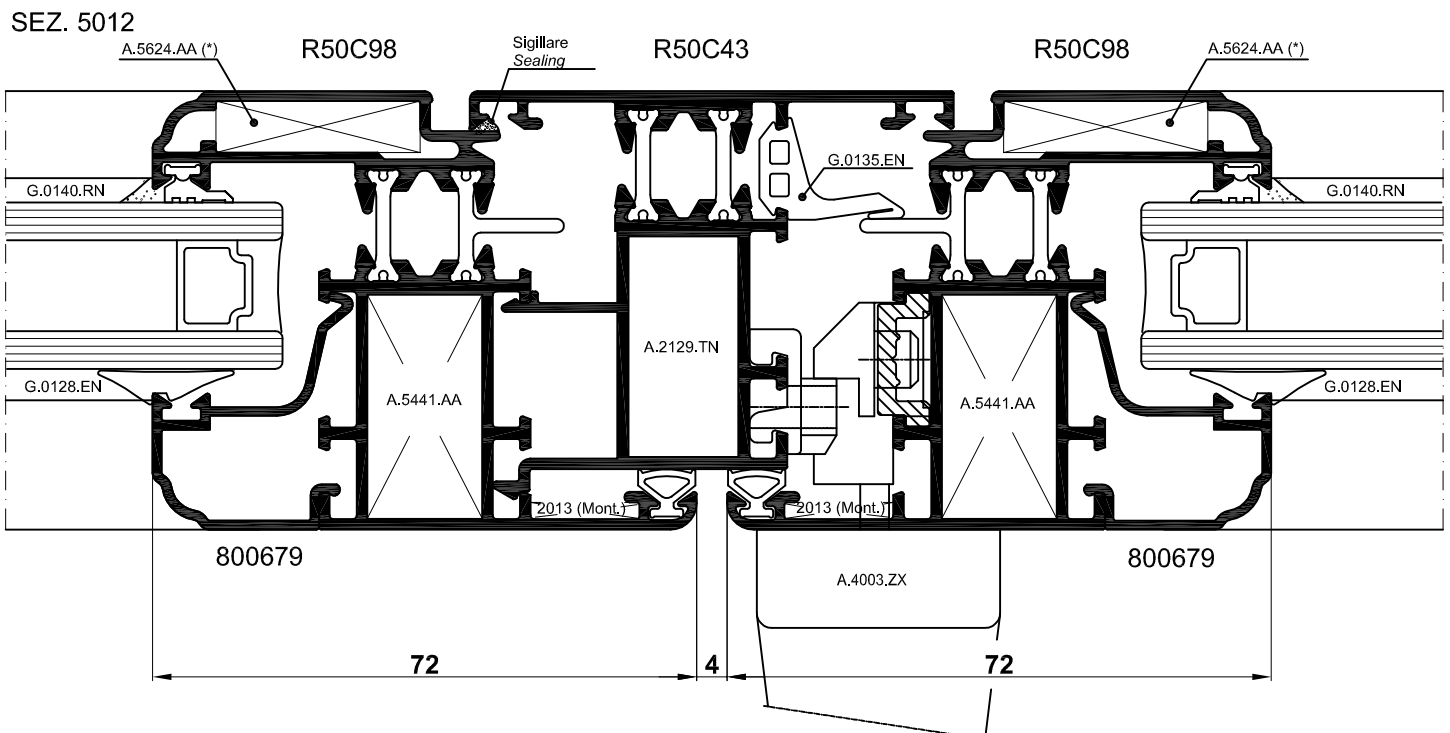
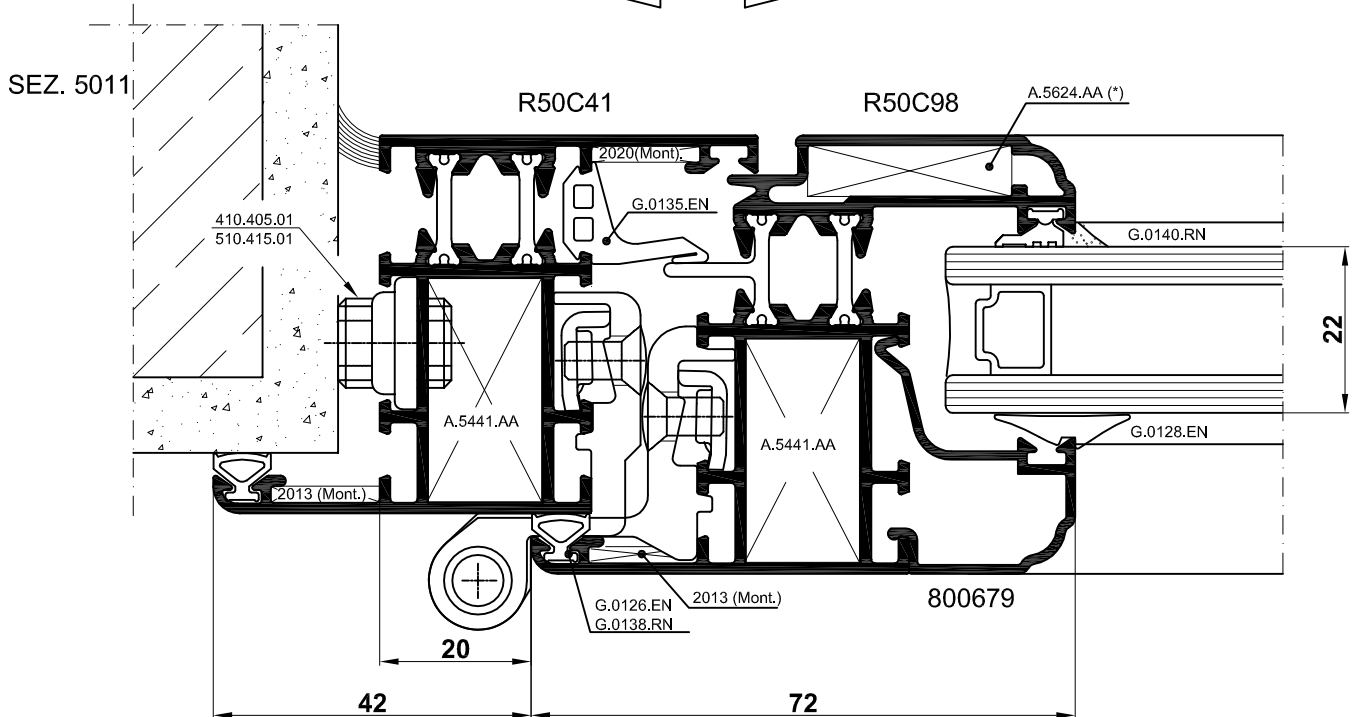

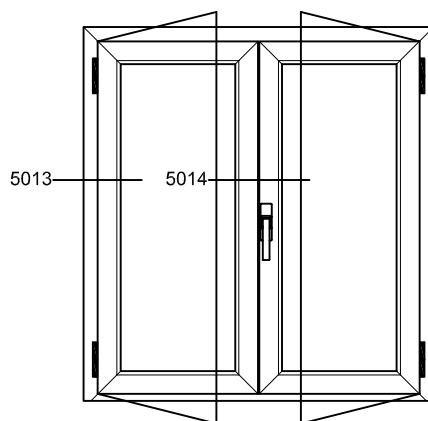

(*) Negli angoli a 45° le squadrette inserite nel tubolare esterno devono essere sempre incollate e cianfrinate. Cianfrinatura eseguibile anche con attrezzatura manuale Cod. M.2001.OO
In the 45° corners, the corner joints in the external tubular section, must always be glued and caulked. Caulking may also be carried out by hand with equipment Art.M.2001.OO

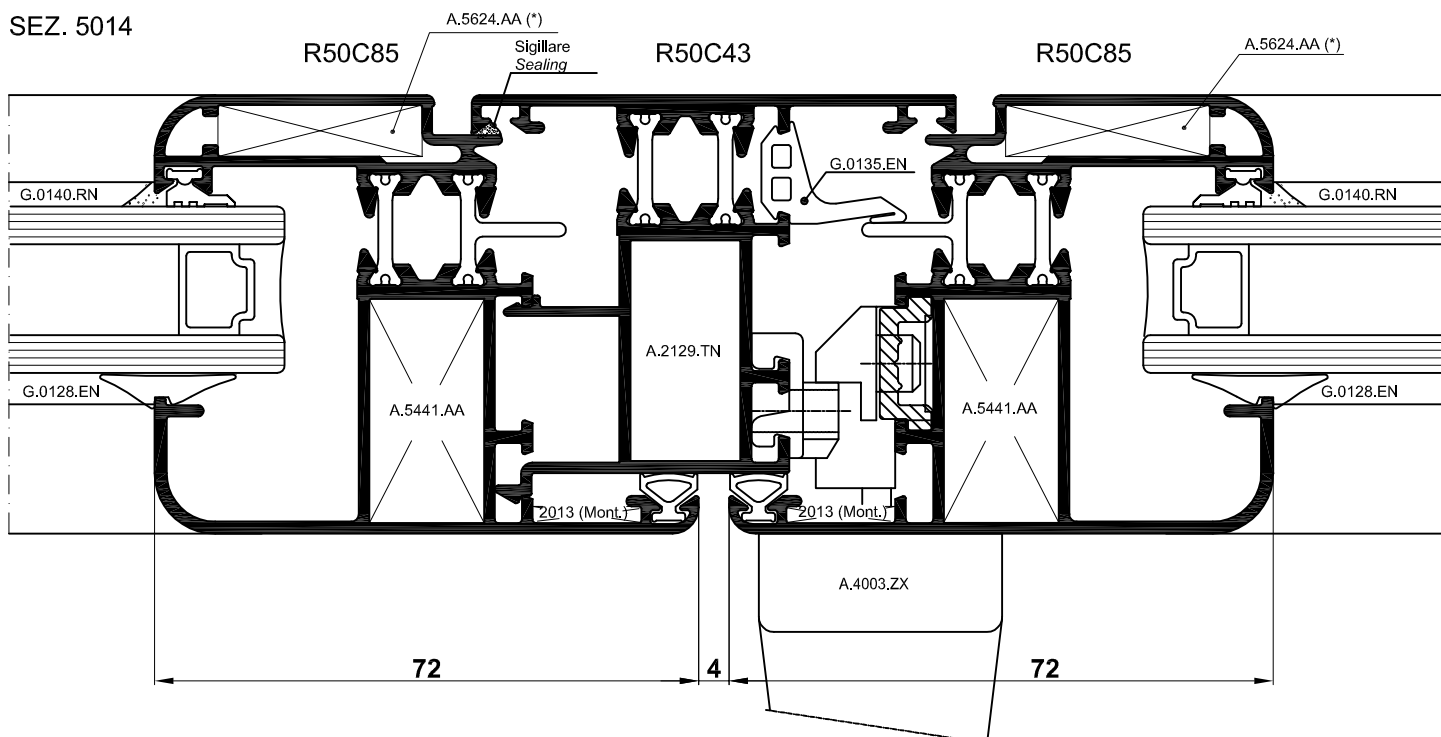
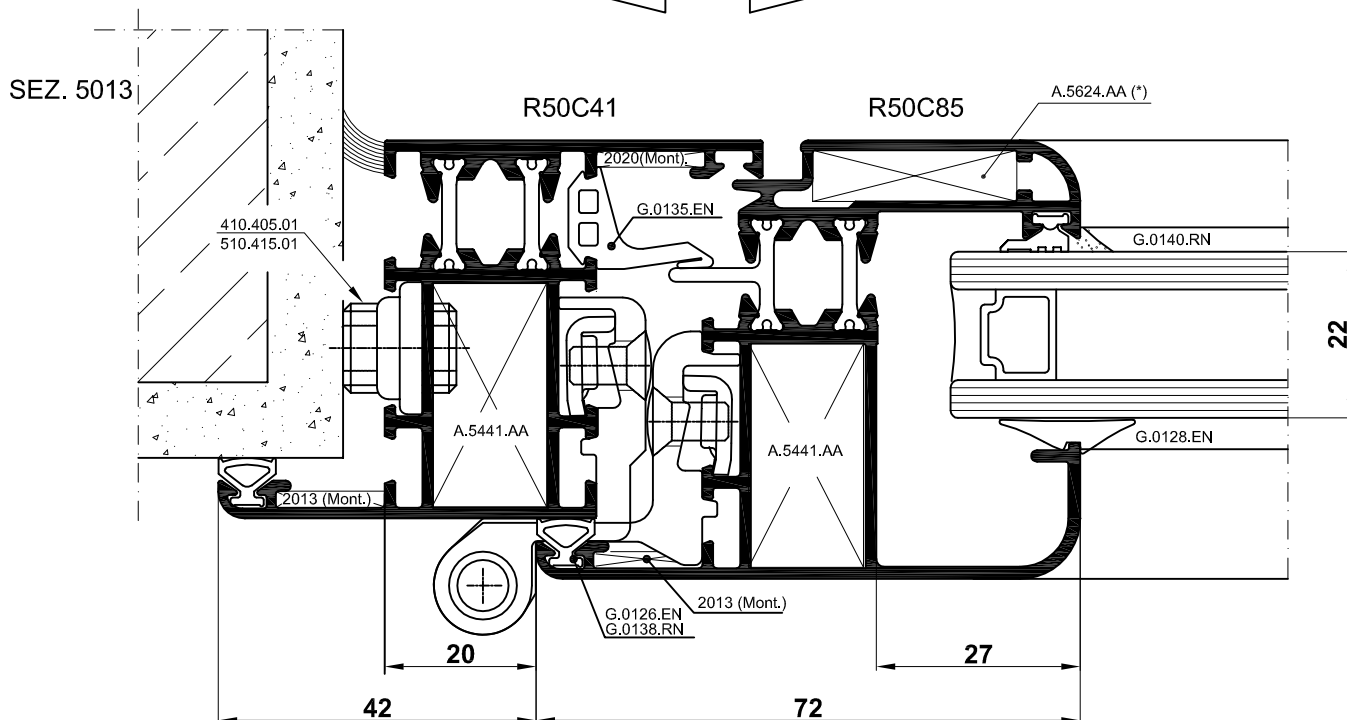

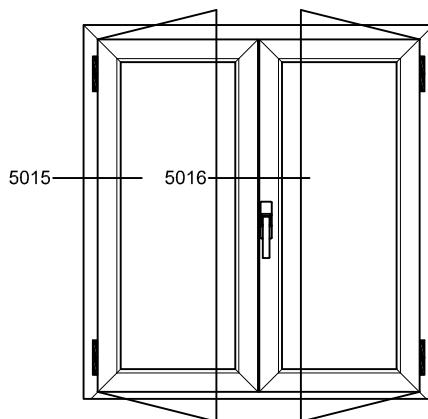

(*) Negli angoli a 45° le squadrette inserite nel tubolare esterno devono essere sempre incollate e cianfrinate. Cianfrinatura eseguibile anche con attrezzatura manuale Cod. M.2001.OO
In the 45° corners, the corner joints in the external tubular section, must always be glued and caulked. Caulking may also be carried out by hand with equipment Art.M.2001.OO

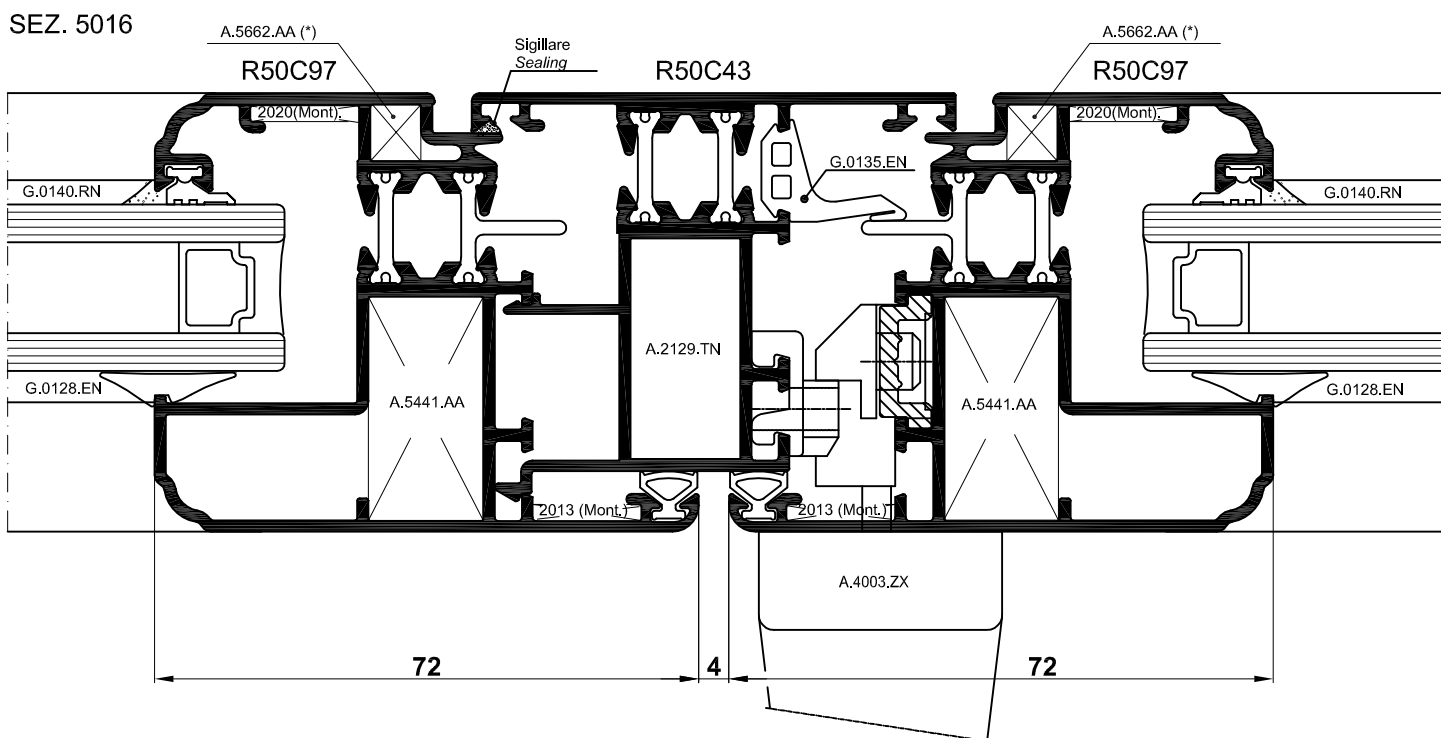
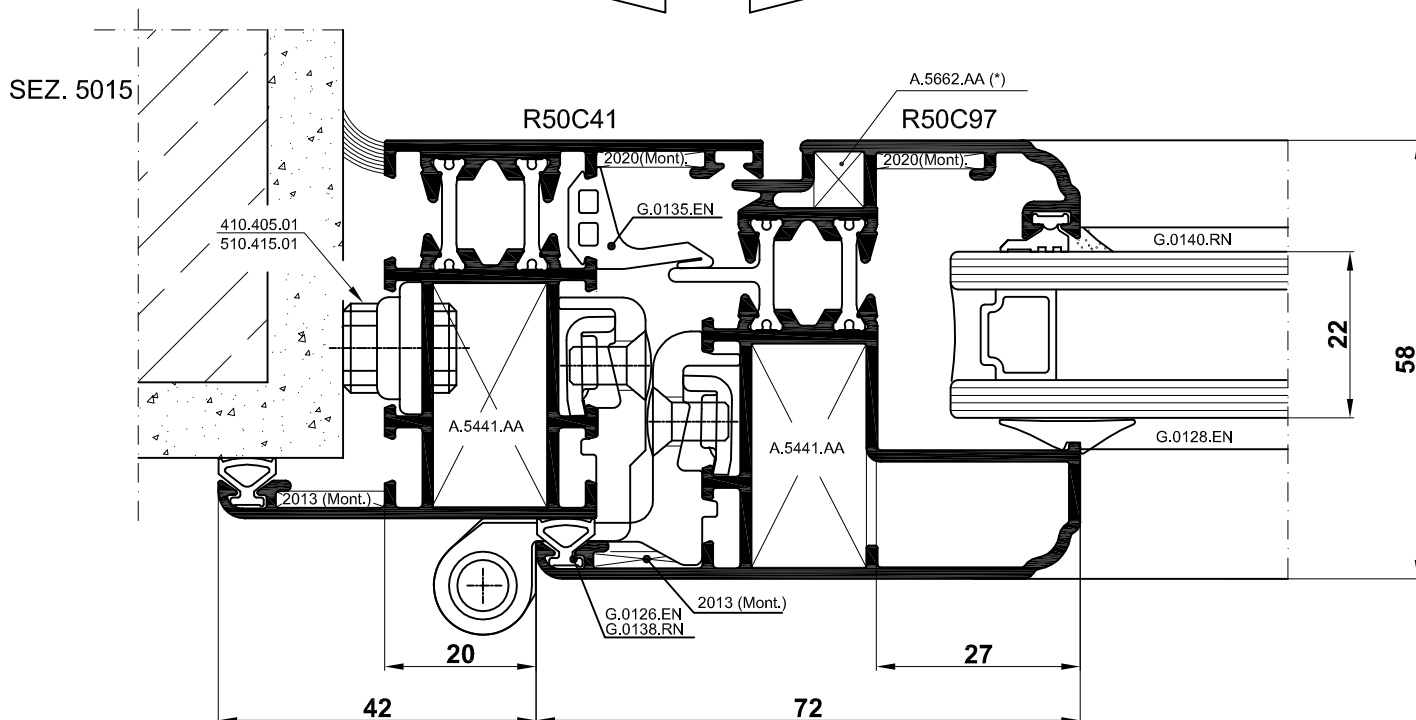

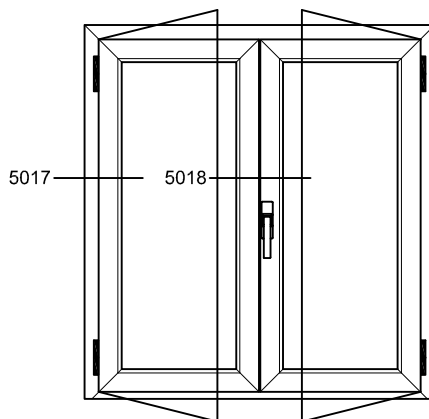

(*) Negli angoli a 45° le squadrette inserite nel tubolare esterno devono essere sempre incollate e cianfrinate. Cianfrinatura eseguibile anche con attrezzatura manuale Cod. M.2001.OO
In the 45° corners, the corner joints in the external tubular section, must always be glued and caulked. Caulking may also be carried out by hand with equipment Art.M.2001.OO

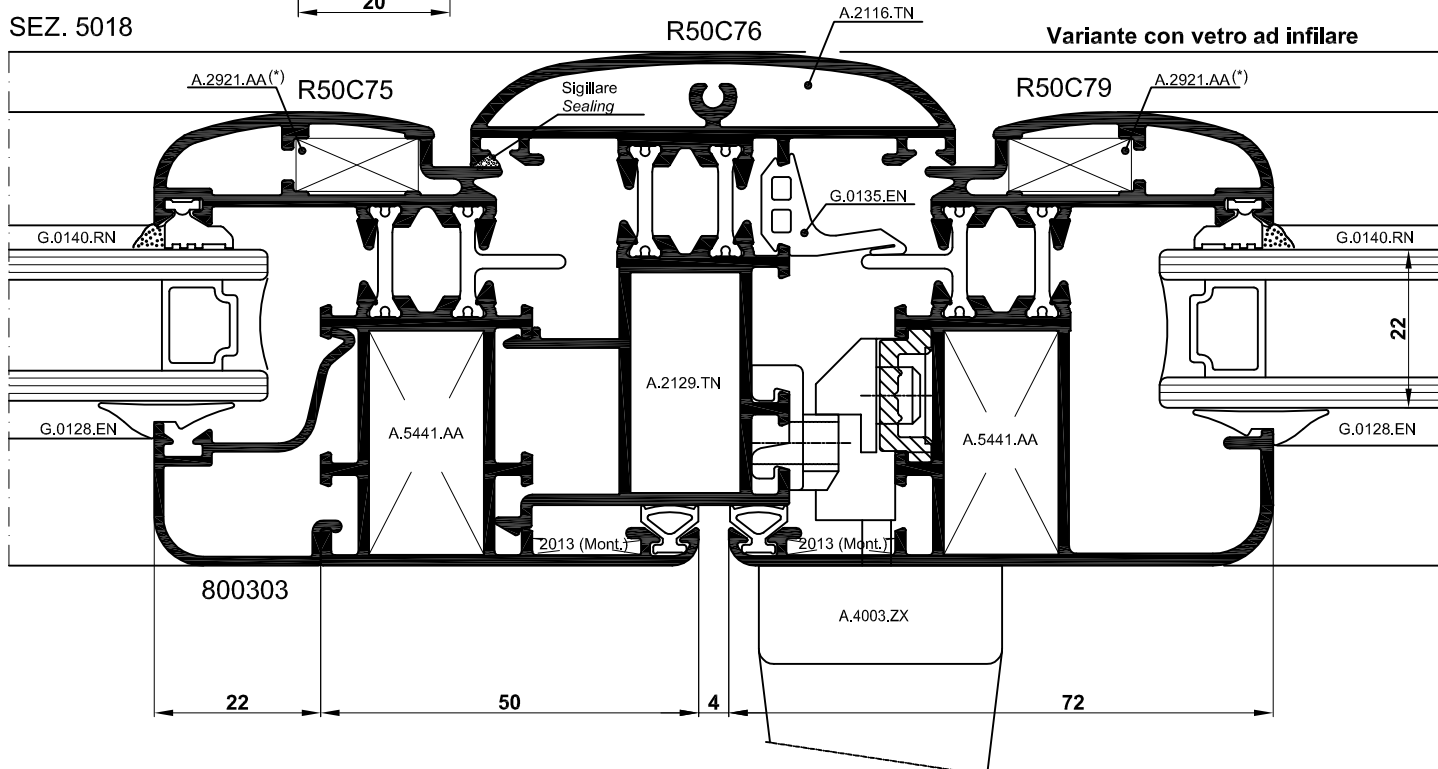
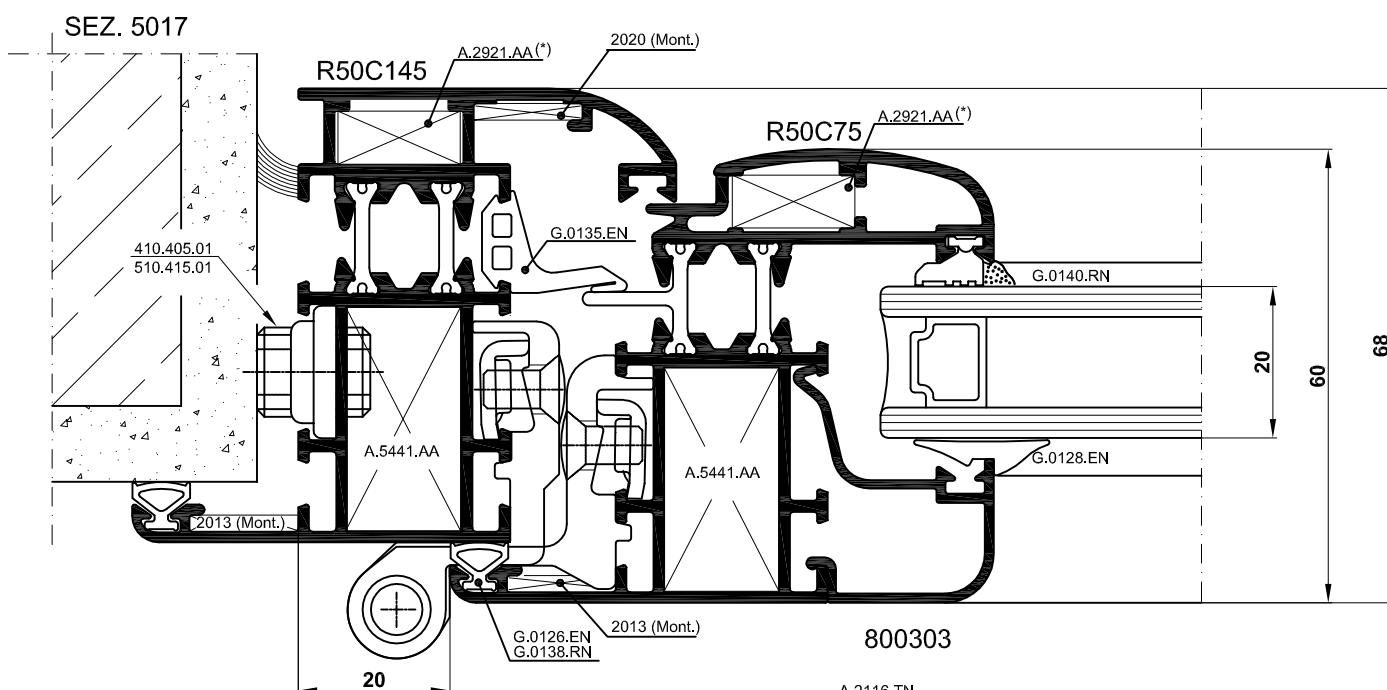

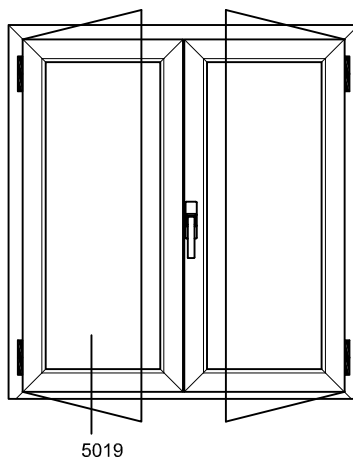

(*) Negli angoli a 45° le squadrette inserite nel tubolare esterno devono essere sempre incollate e cianfrinate. Cianfrinatura eseguibile anche con attrezzatura manuale Cod. M.2001.OO
 In the 45° corners, the corner joints in the external tubular section, must always be glued and caulked. Caulking may also be carried out by hand with equipment Art.M.2001.OO

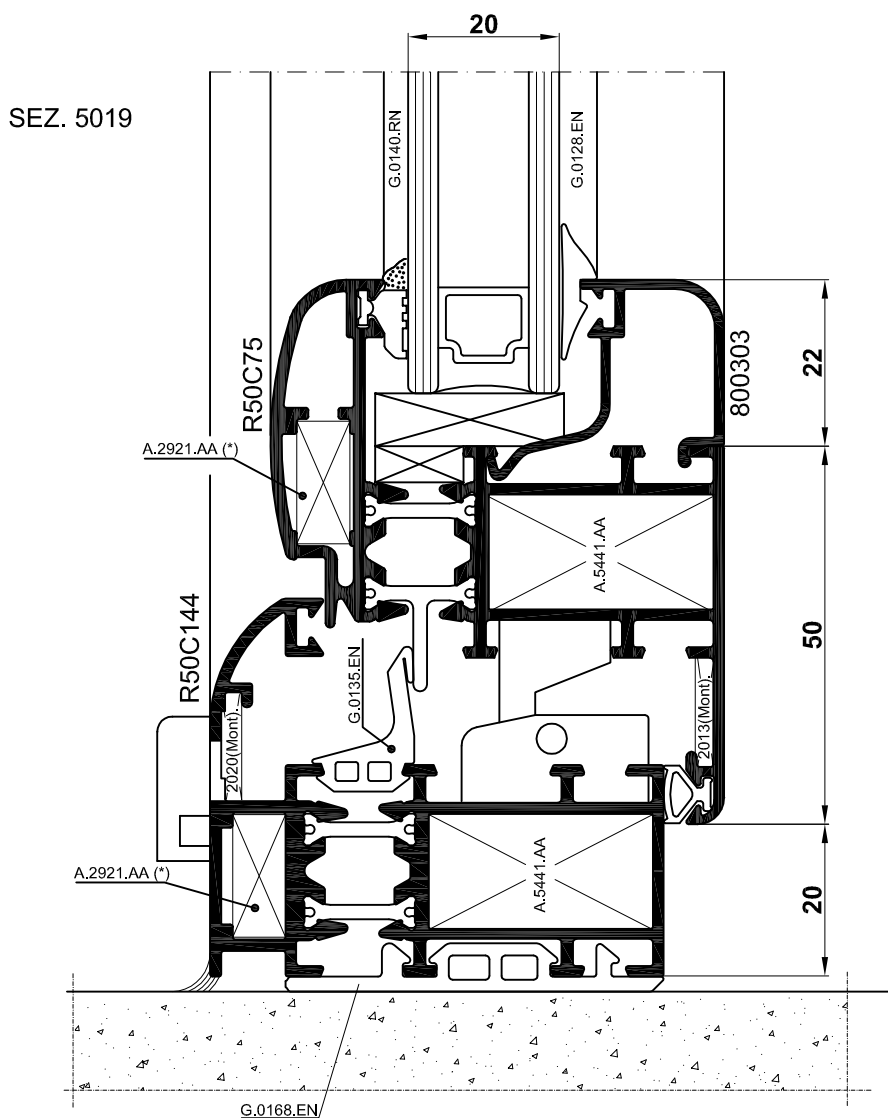

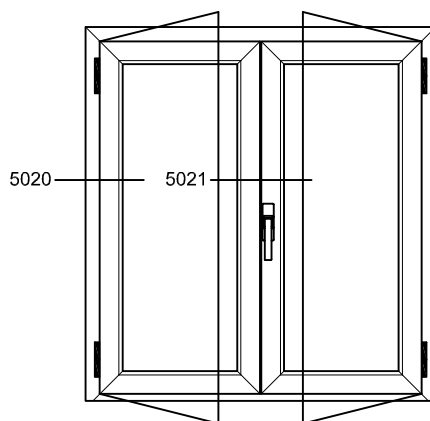

(*) Negli angoli a 45° le squadrette inserite nel tubolare esterno devono essere sempre incollate e cianfrinate. Cianfrinatura eseguibile anche con attrezzatura manuale Cod. M.2001.OO
In the 45° corners, the corner joints in the external tubular section, must always be glued and caulked. Caulking may also be carried out by hand with equipment Art.M.2001.OO

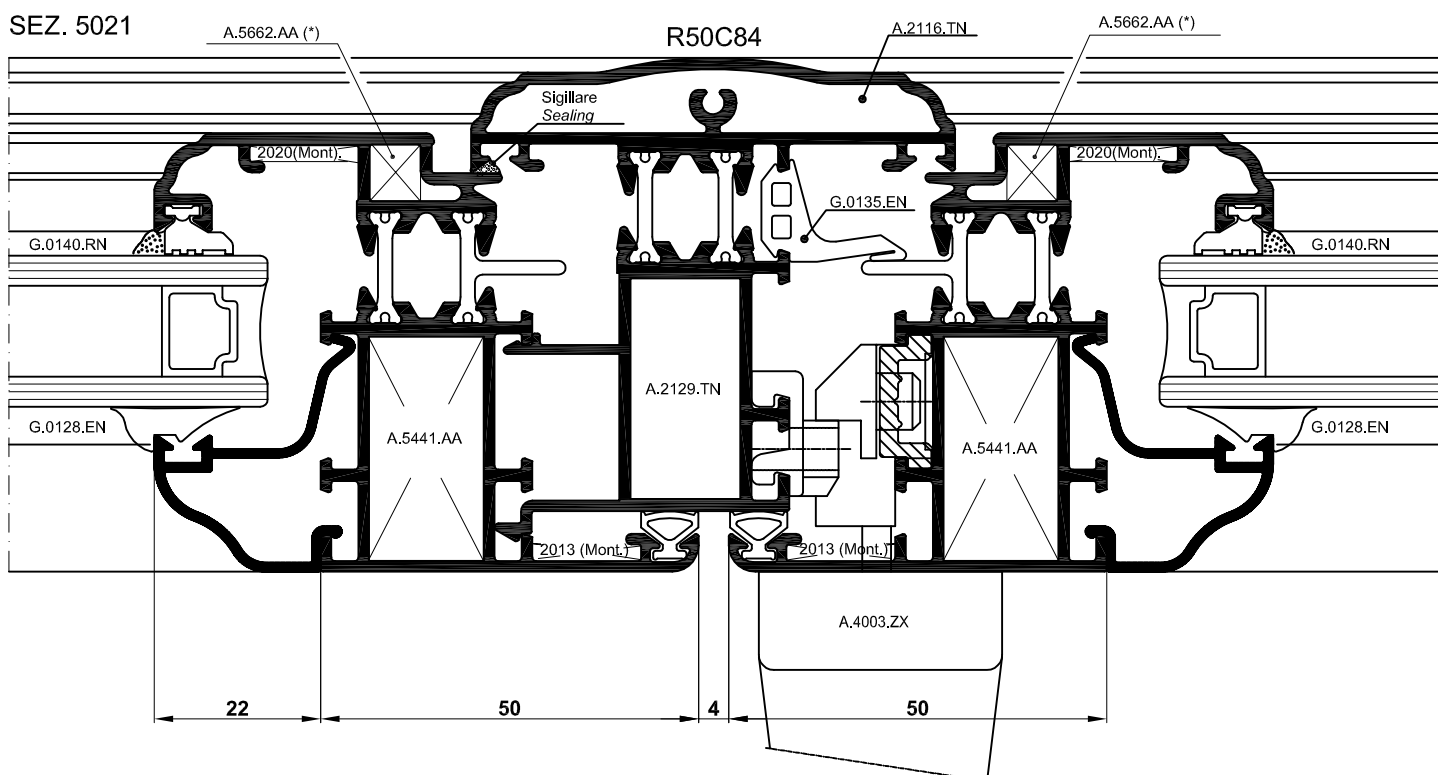
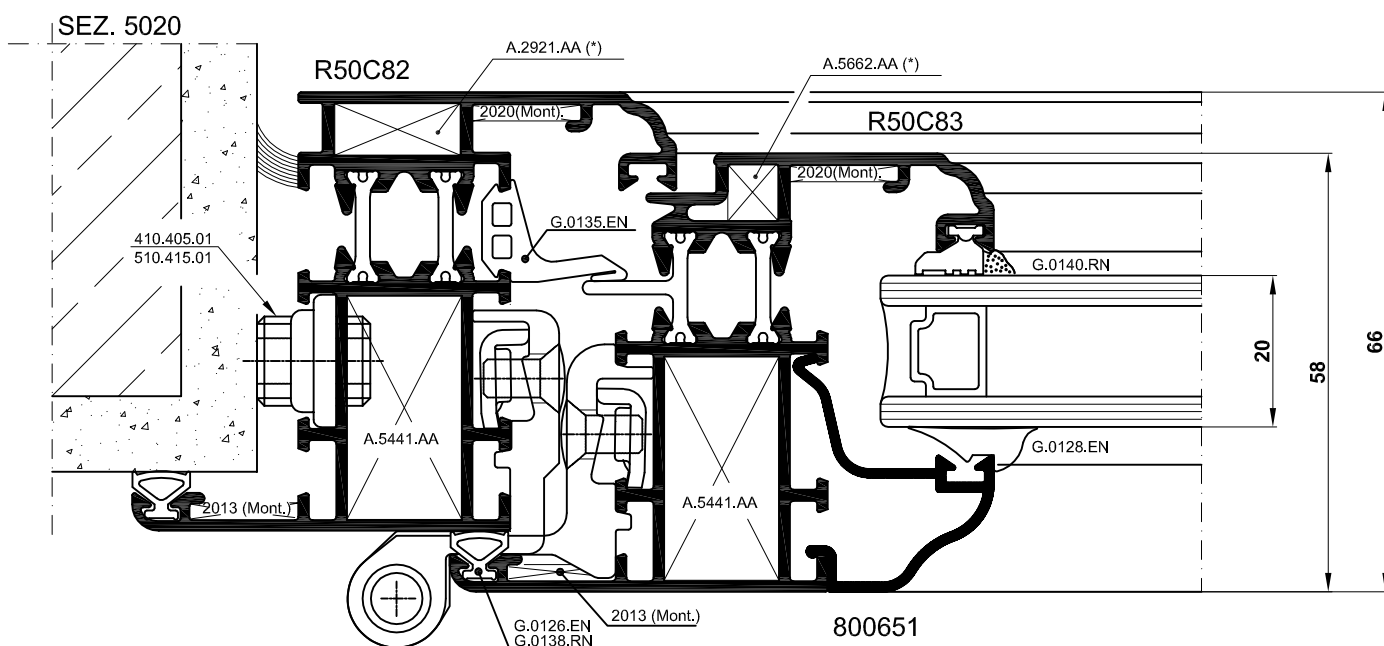

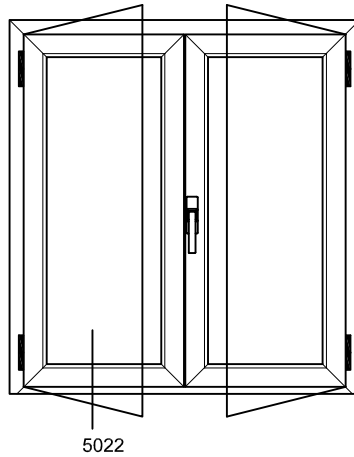

(*) Negli angoli a 45° le squadrette inserite nel tubolare esterno devono essere sempre incollate e cianfrinate. Cianfrinatura eseguibile anche con attrezzatura manuale Cod. M.2001.OO
In the 45° corners, the corner joints in the external tubular section, must always be glued and caulked. Caulking may also be carried out by hand with equipment Art.M.2001.OO

SEZ. 5022

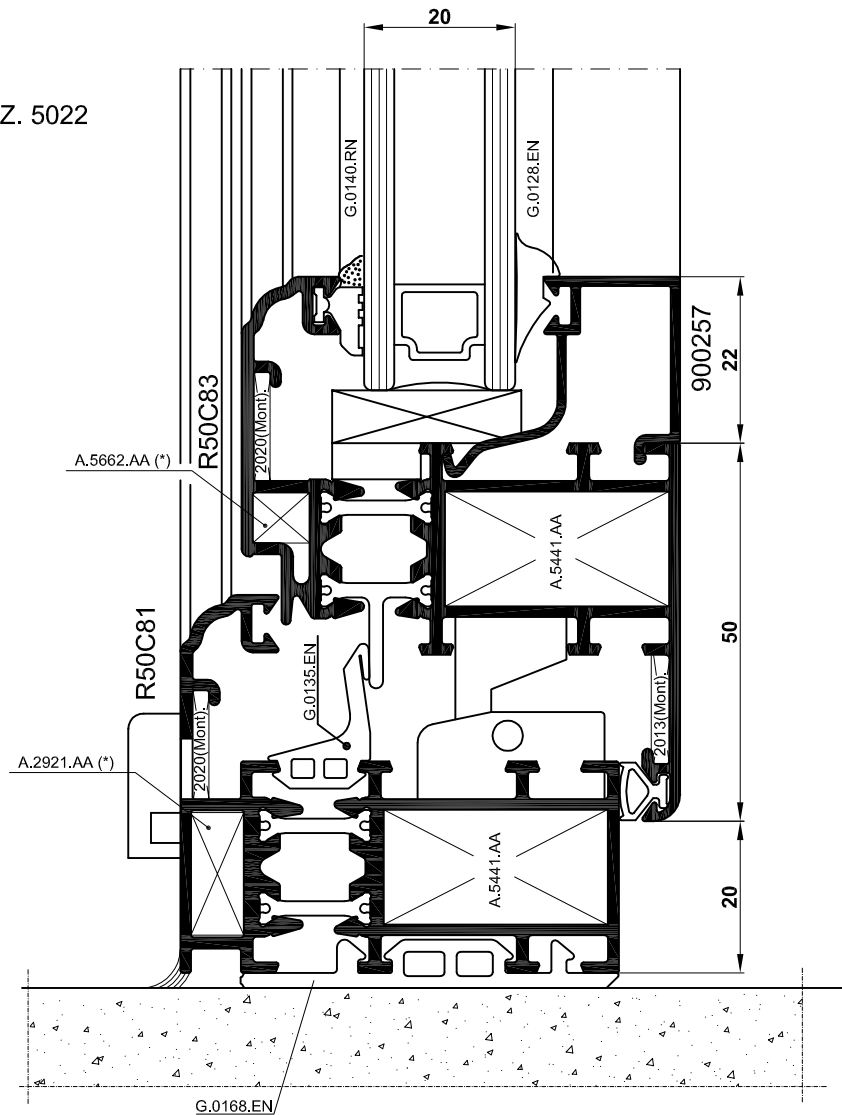

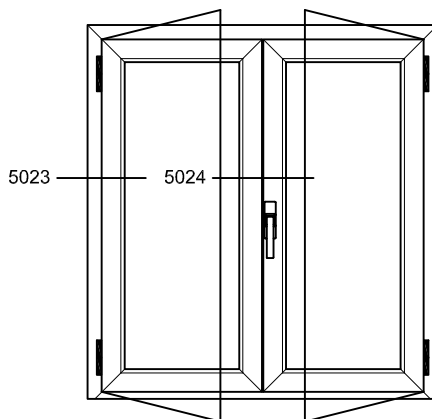

(*) Negli angoli a 45° le squadrette inserite nel tubolare esterno devono essere sempre incollate e cianfrinate. Cianfrinatura eseguibile anche con attrezzatura manuale Cod. M.2001.OO
 In the 45° corners, the corner joints in the external tubular section, must always be glued and caulked. Caulking may also be carried out by hand with equipment Art.M.2001.OO

SEZ. 5023

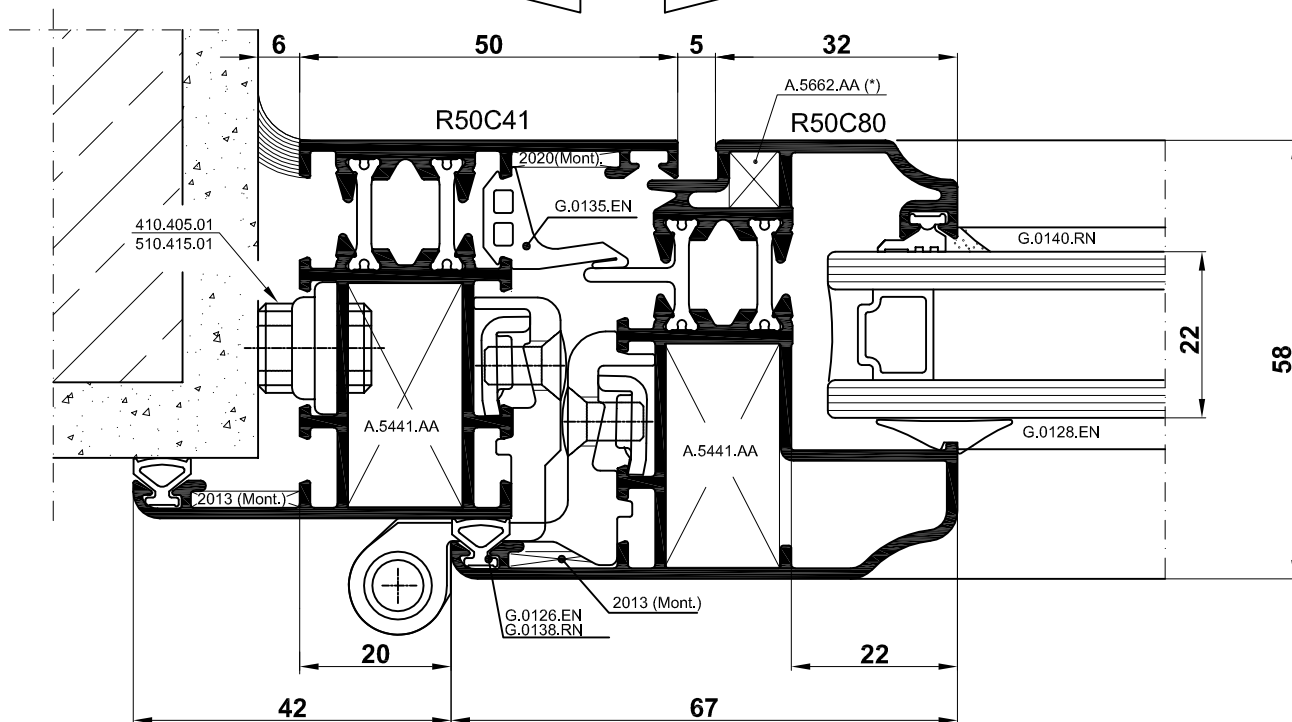

SEZ. 5024

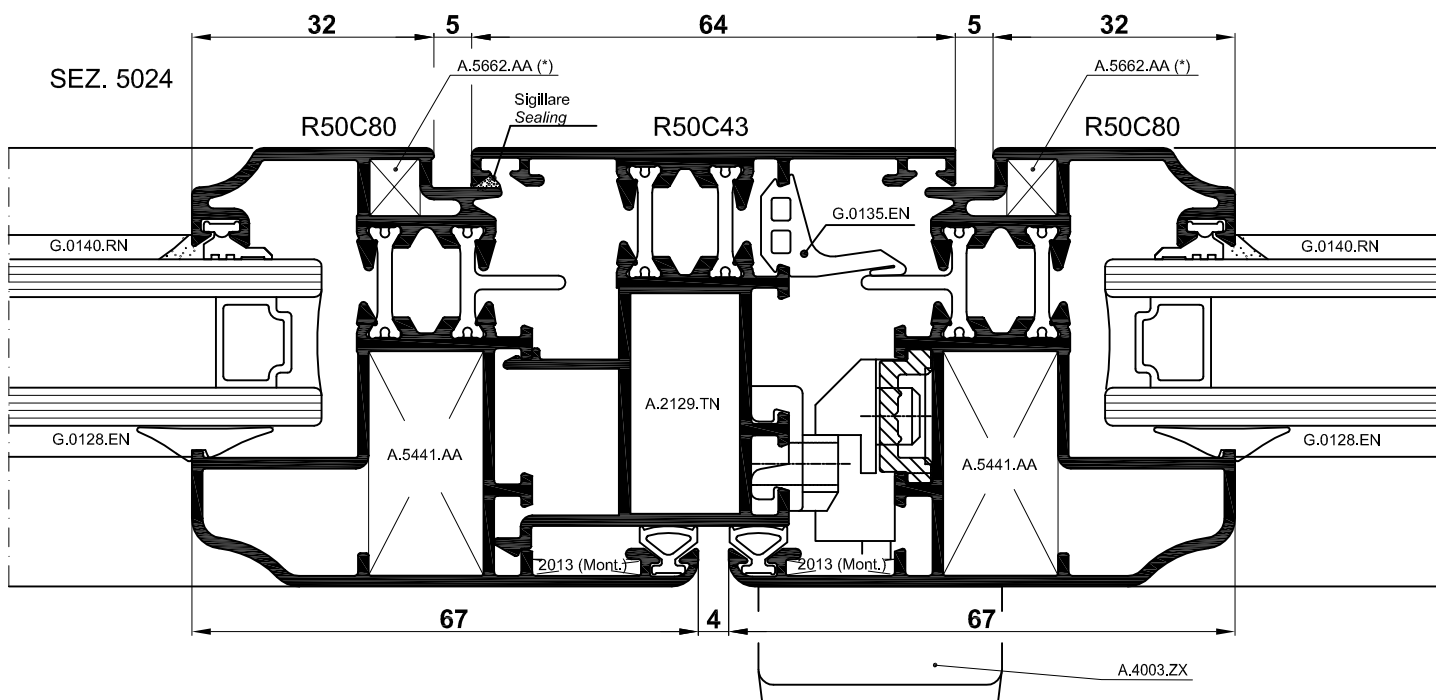

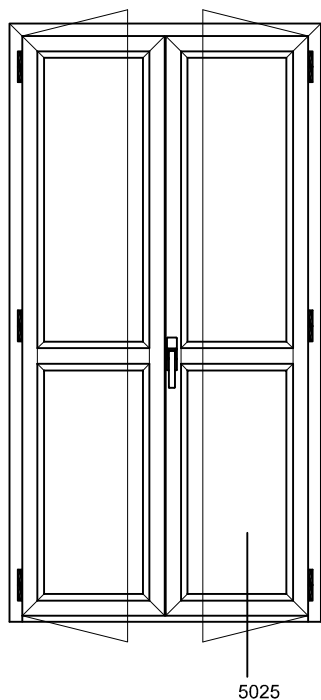

(*) Negli angoli a 45° le squadrette inserite nel tubolare esterno devono essere sempre incollate e cianfrinate.
Cianfrinatura eseguibile anche con attrezzatura manuale Cod. M.2001.OO
In the 45° corners, the corner joints in the external tubular section, must always be glued and caulked. Caulking may also be carried out by hand with equipment Art.M.2001.OO

- Asolare il profilato 100342 in corrispondenza della lavorazione della ventilazione dei vetri
Slot the profile 100342 matching the glass ventilation processing

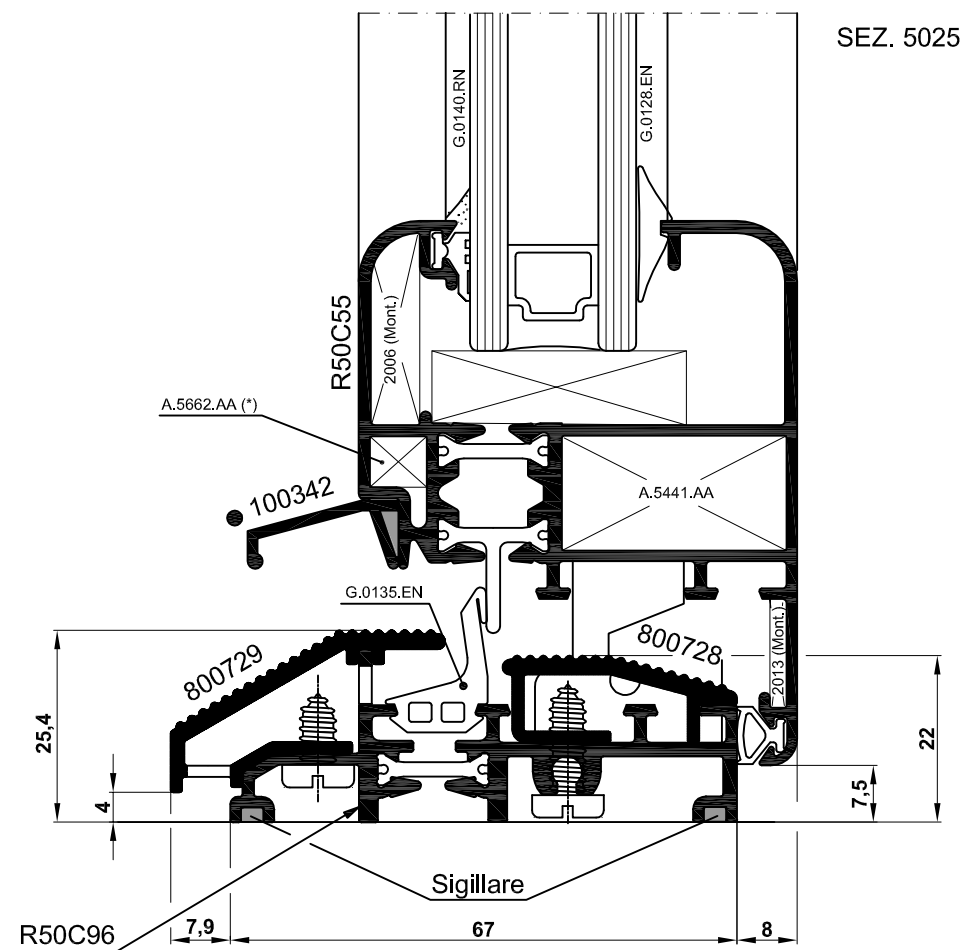

(*) Negli angoli a 45° le squadrette inserite nel tubolare esterno devono essere sempre incollate e cianfrinate. Cianfrinatura eseguibile anche con attrezzatura manuale Cod. M.2001.OO
In the 45° corners, the corner joints in the external tubular section, must always be glued and caulked. Caulking may also be carried out by hand with equipment Art.M.2001.OO

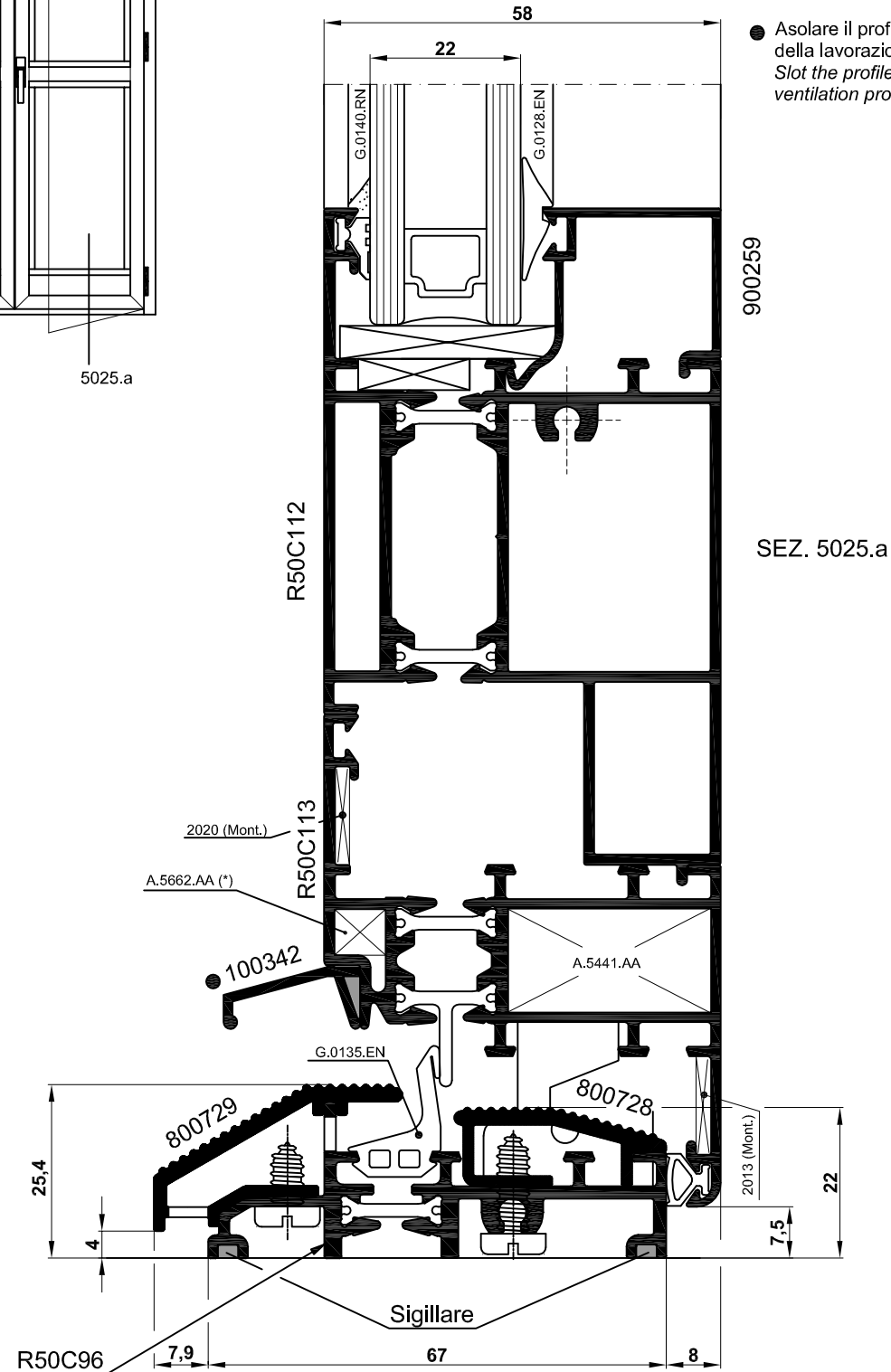
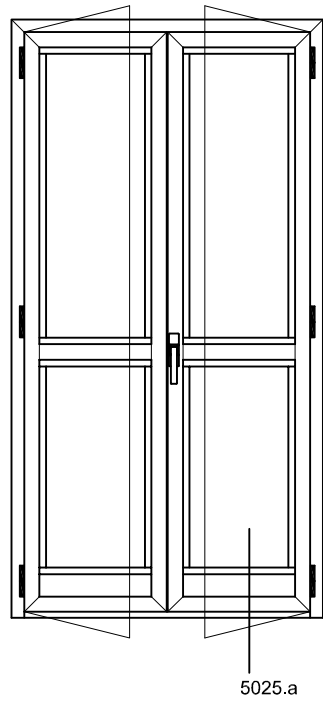

● Asolare il profilato 100342 in corrispondenza della lavorazione della ventilazione dei vetri
Slot the profile 100342 matching the glass ventilation processing

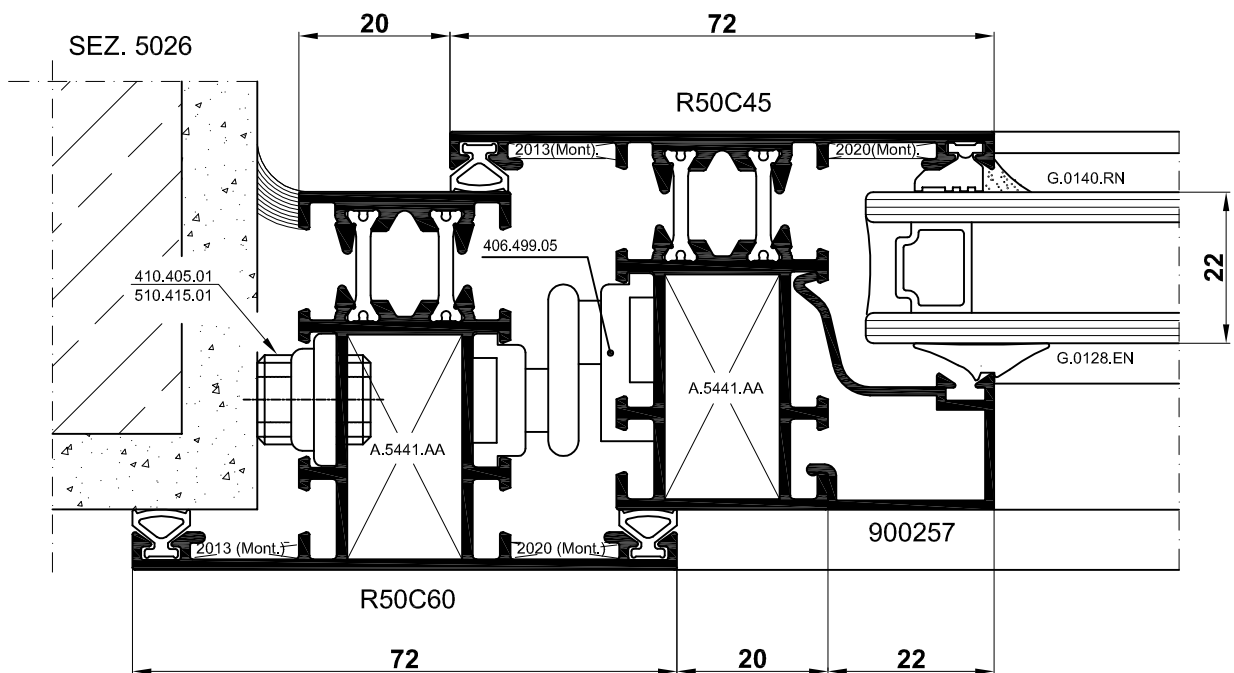
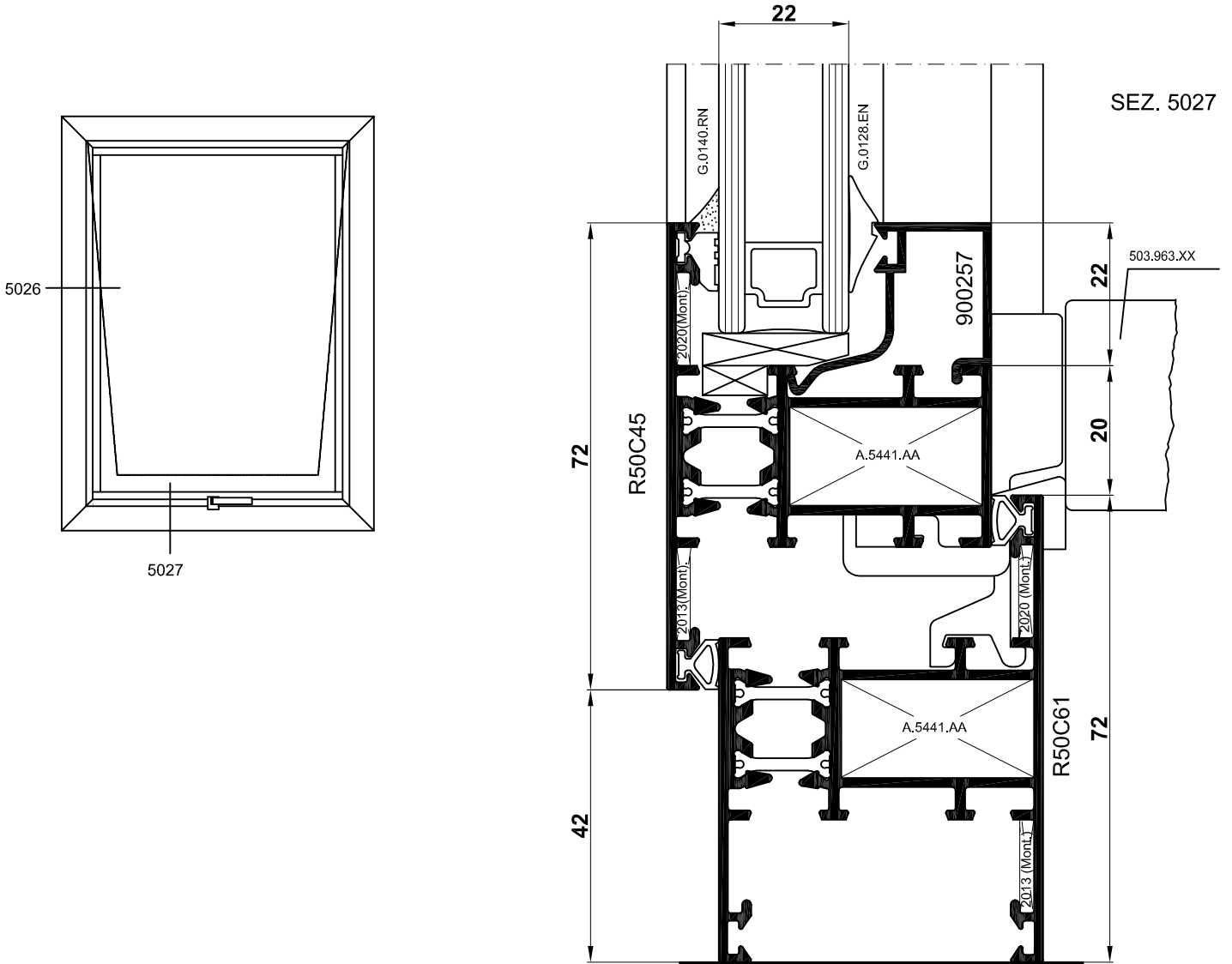

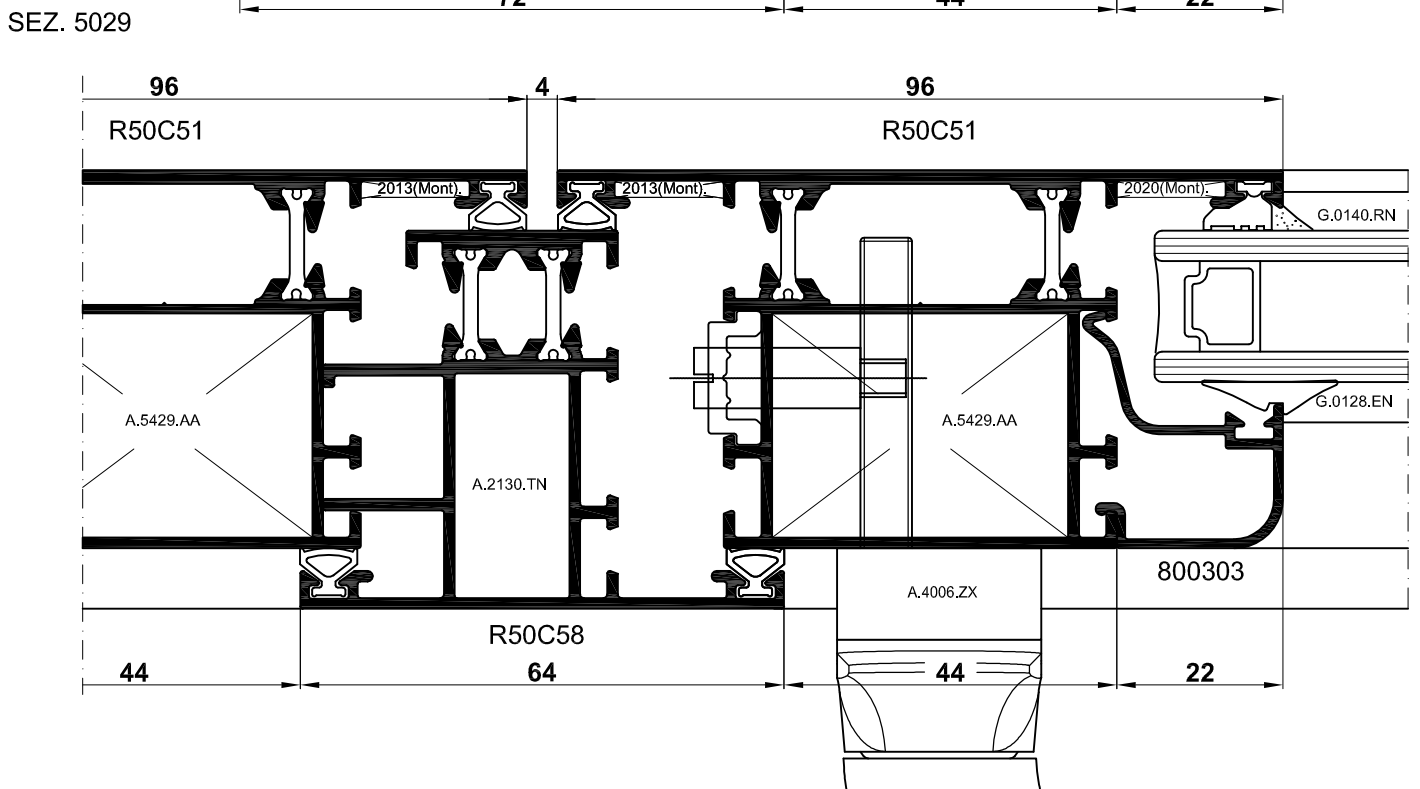
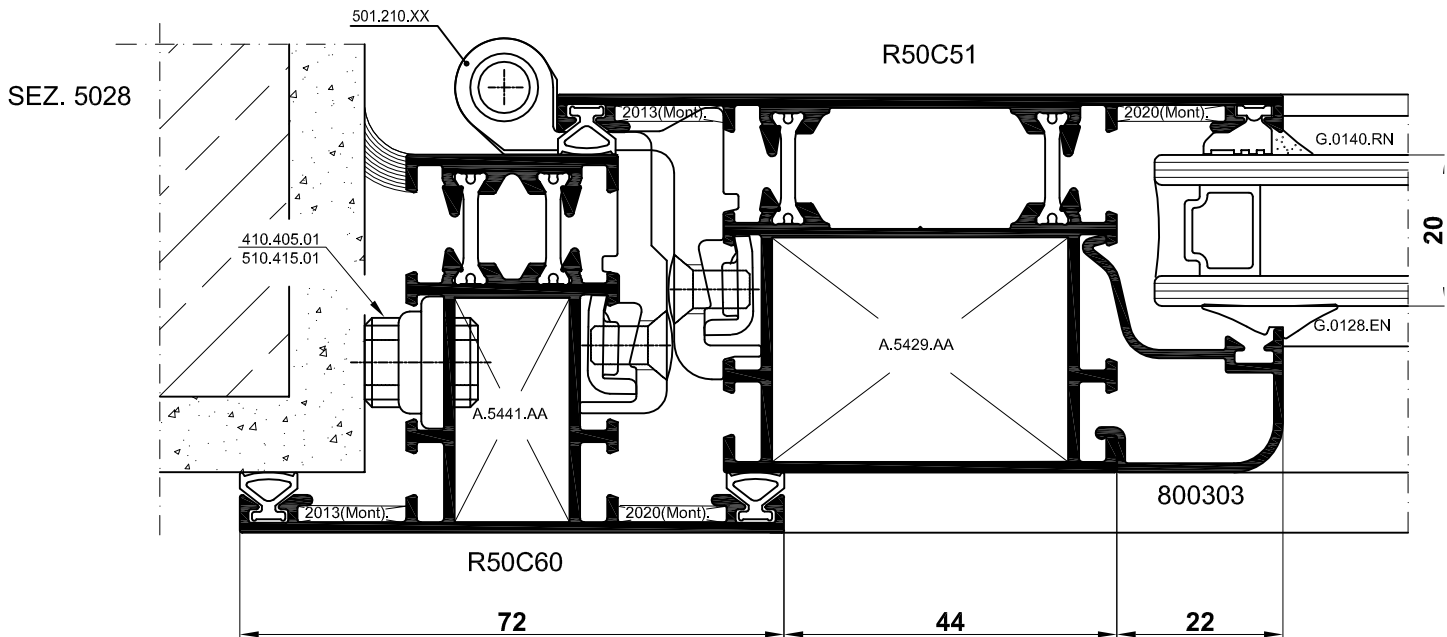
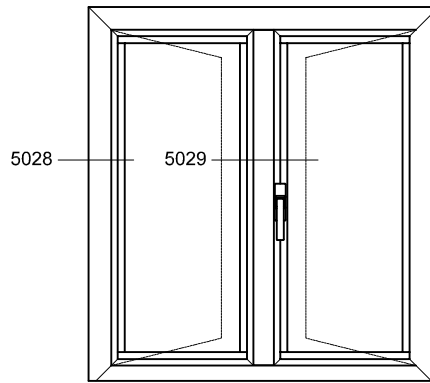

SEZIONI - PORTA DUE ANTE + FISSO APERTURA ESTERNA CON PROF. R50C104
SECTIONS - TWO WINGS + FIX DOOR OUTWARD OPENING WITH R50C104

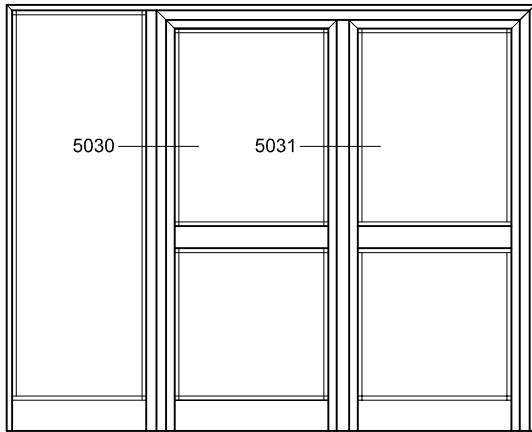

SEZ. 5030

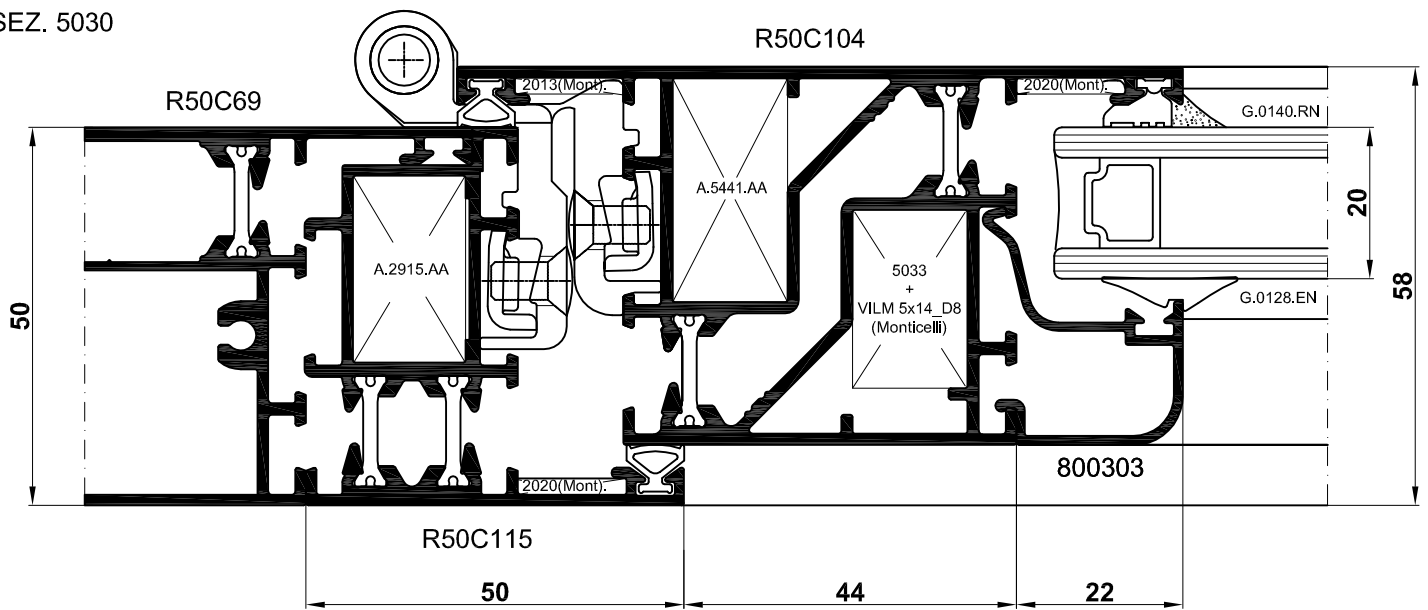

SEZ. 5031

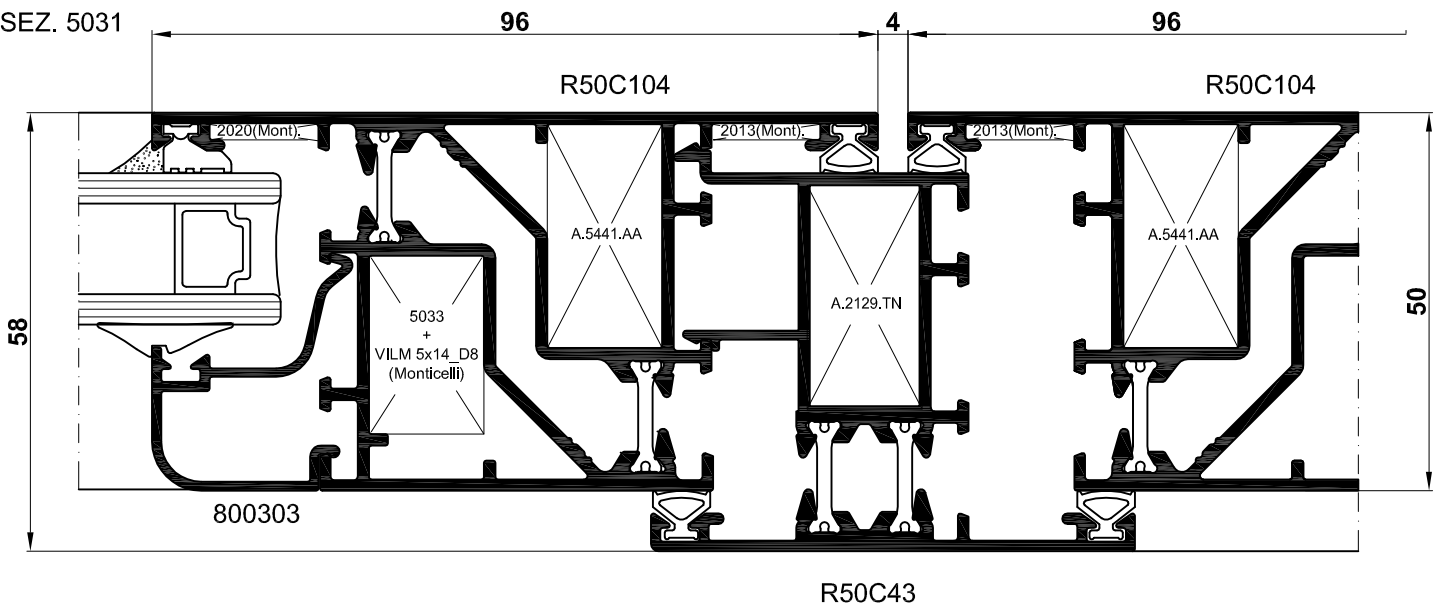

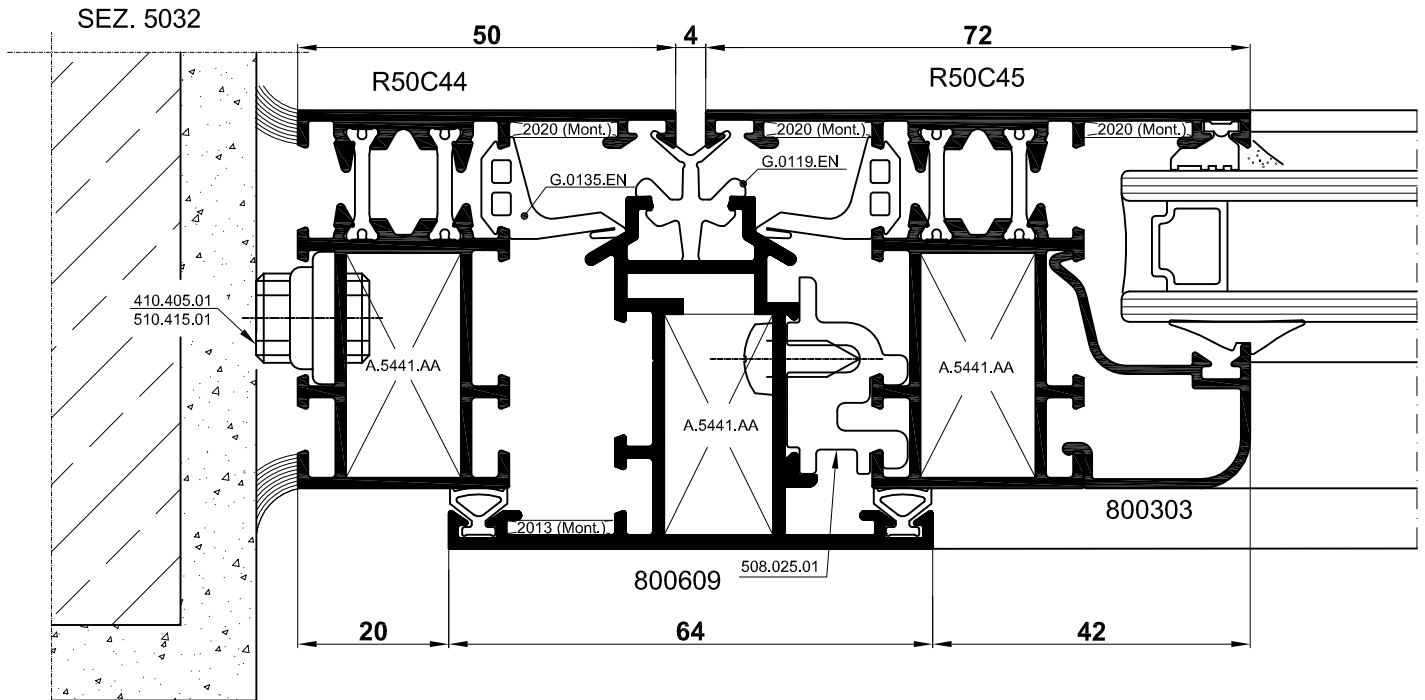
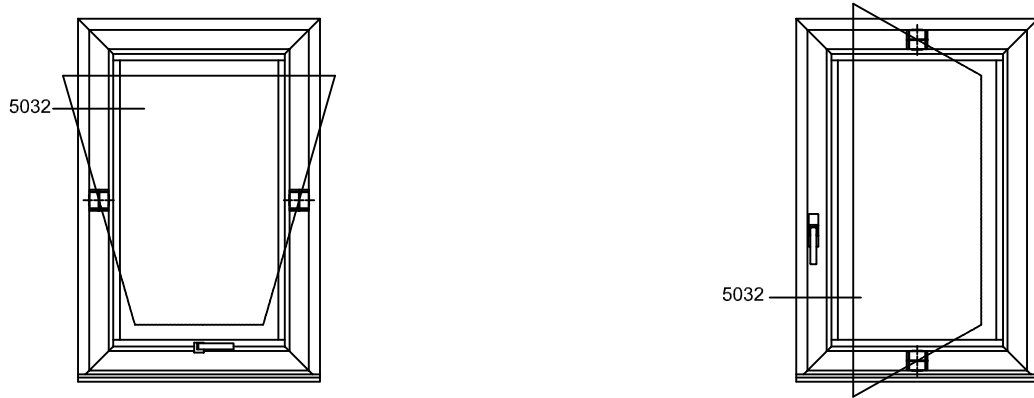

SEZIONI - LAVORAZIONE PROFILO 800609
CROSS SECTIONS - TOOLING FOR SECTION 800609

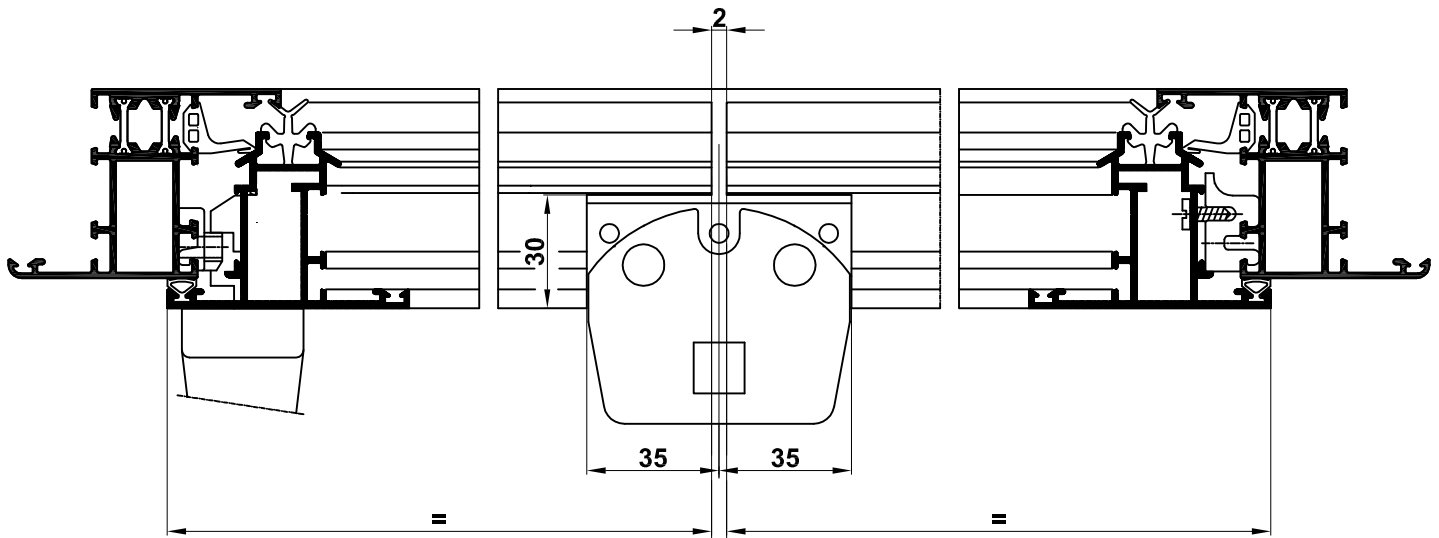

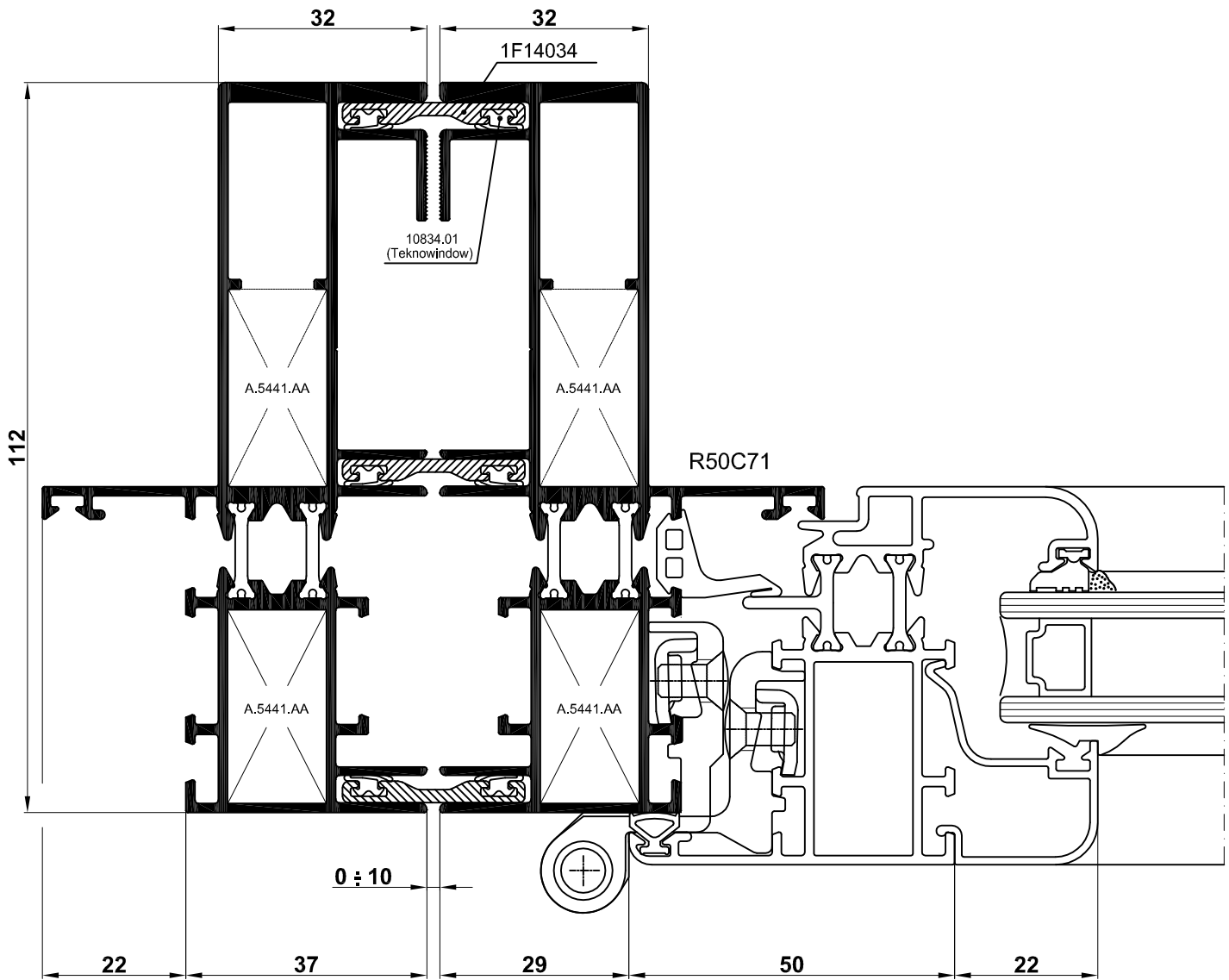

SEZIONI - APPLICAZIONE SOGLIA E PORTAGUARNIZIONE SOTTOZOCOLO
SECTIONS - APPLICATION OF THRESHOLD AND SKIRTING BOARD WEATHERSTRIP HOLDER

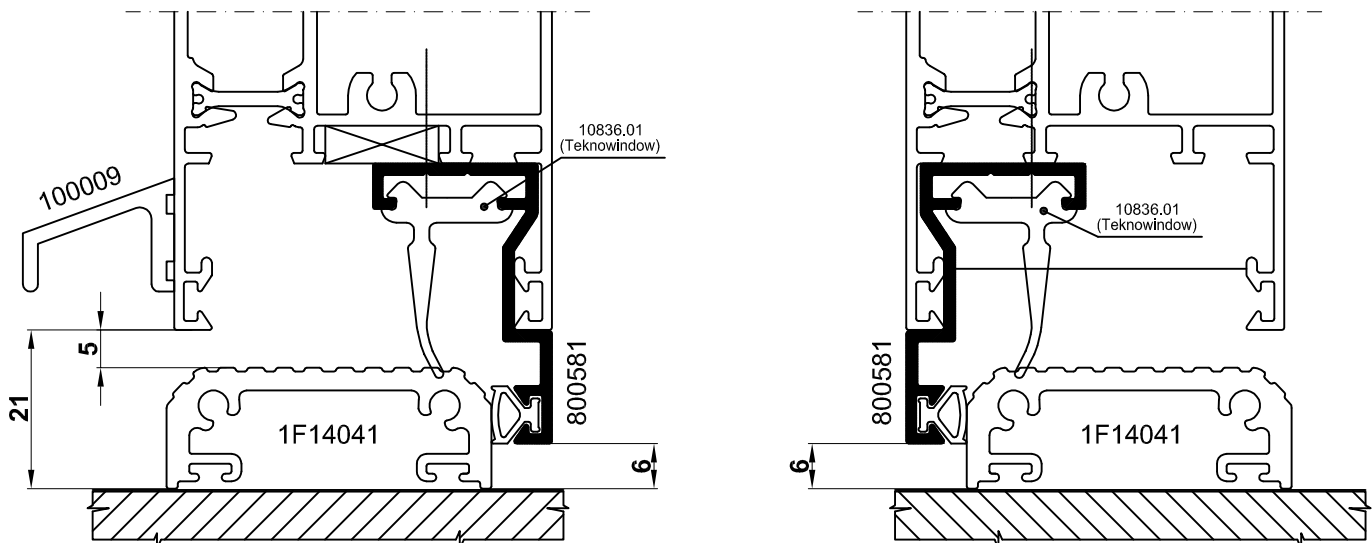

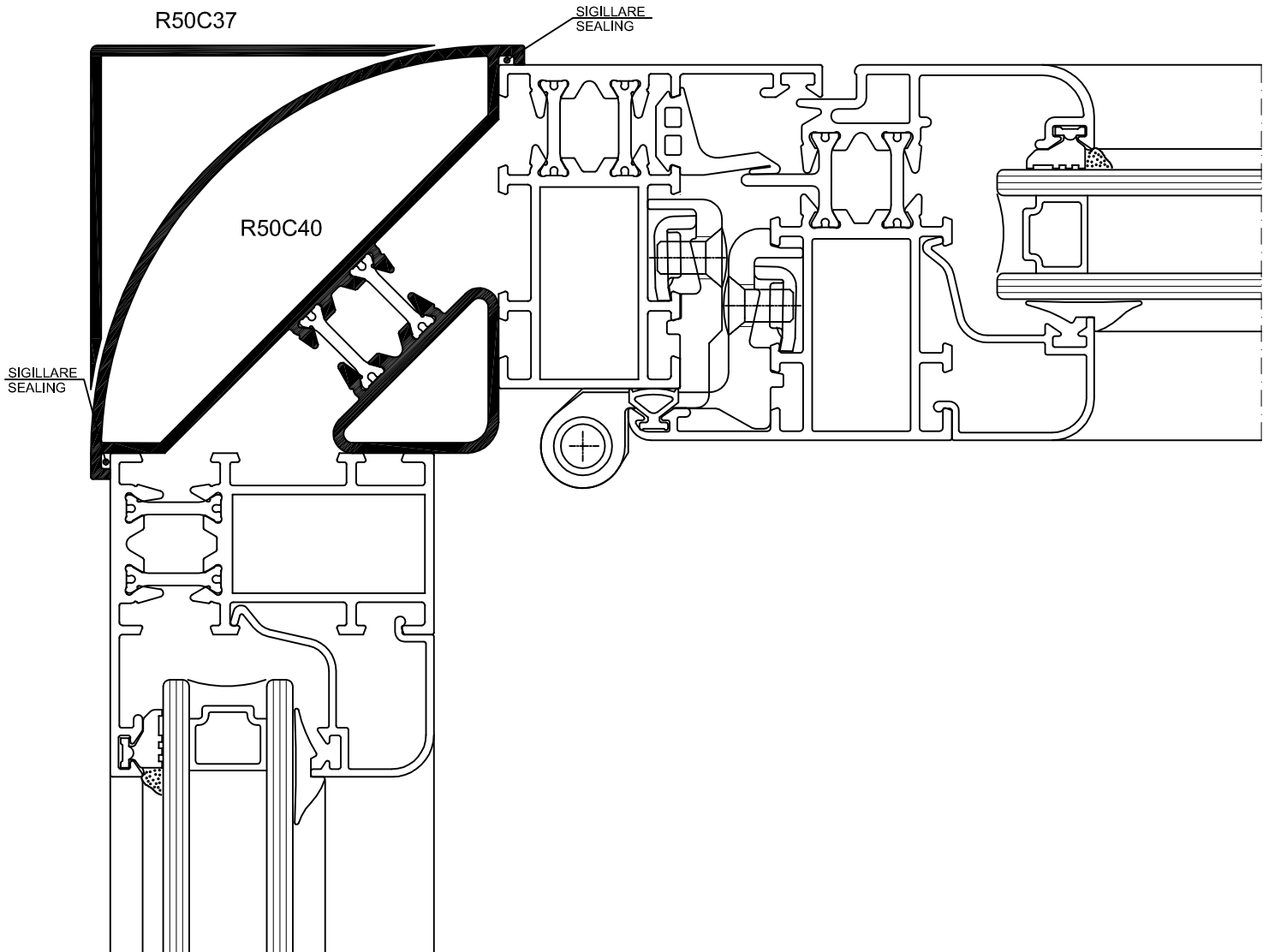

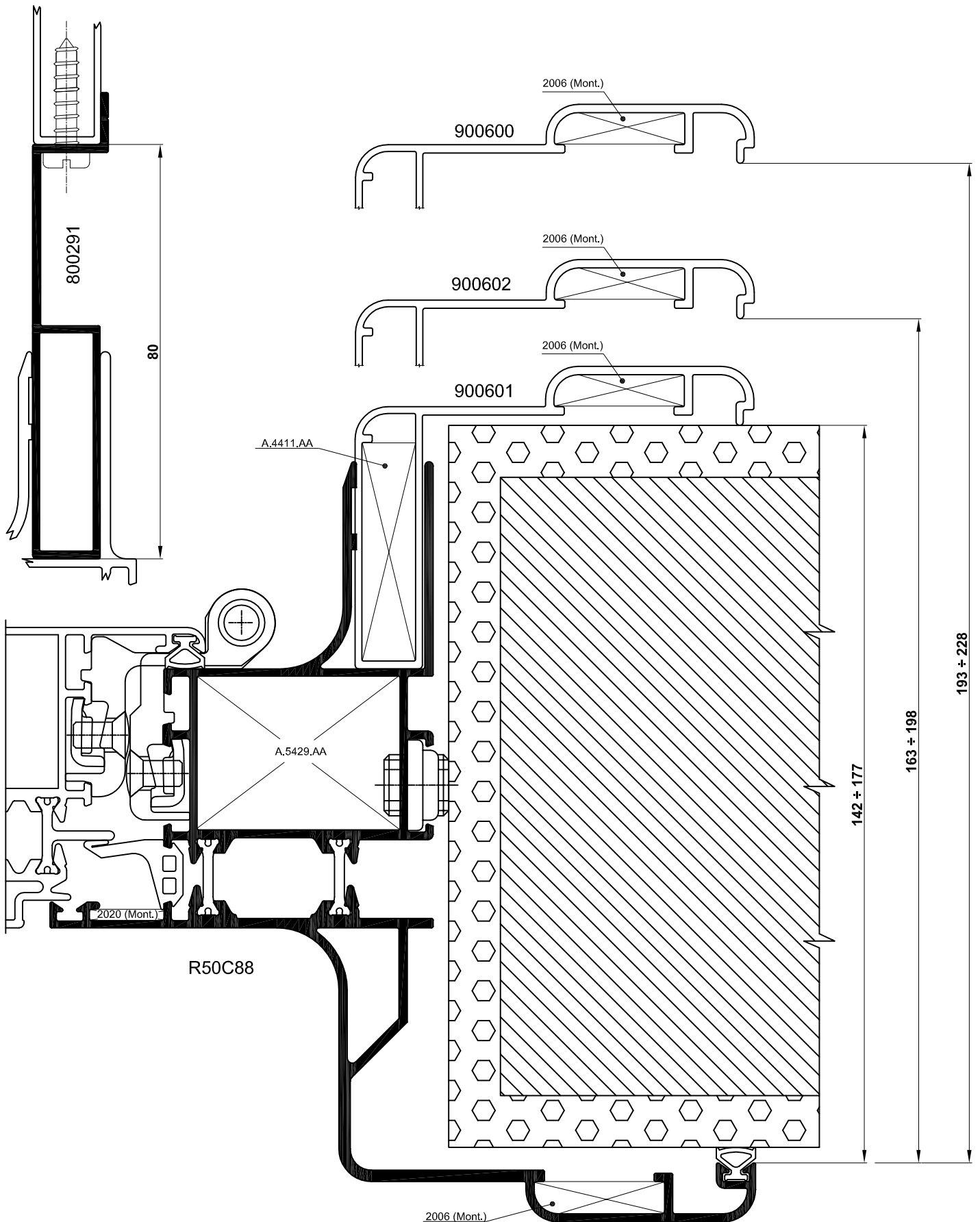

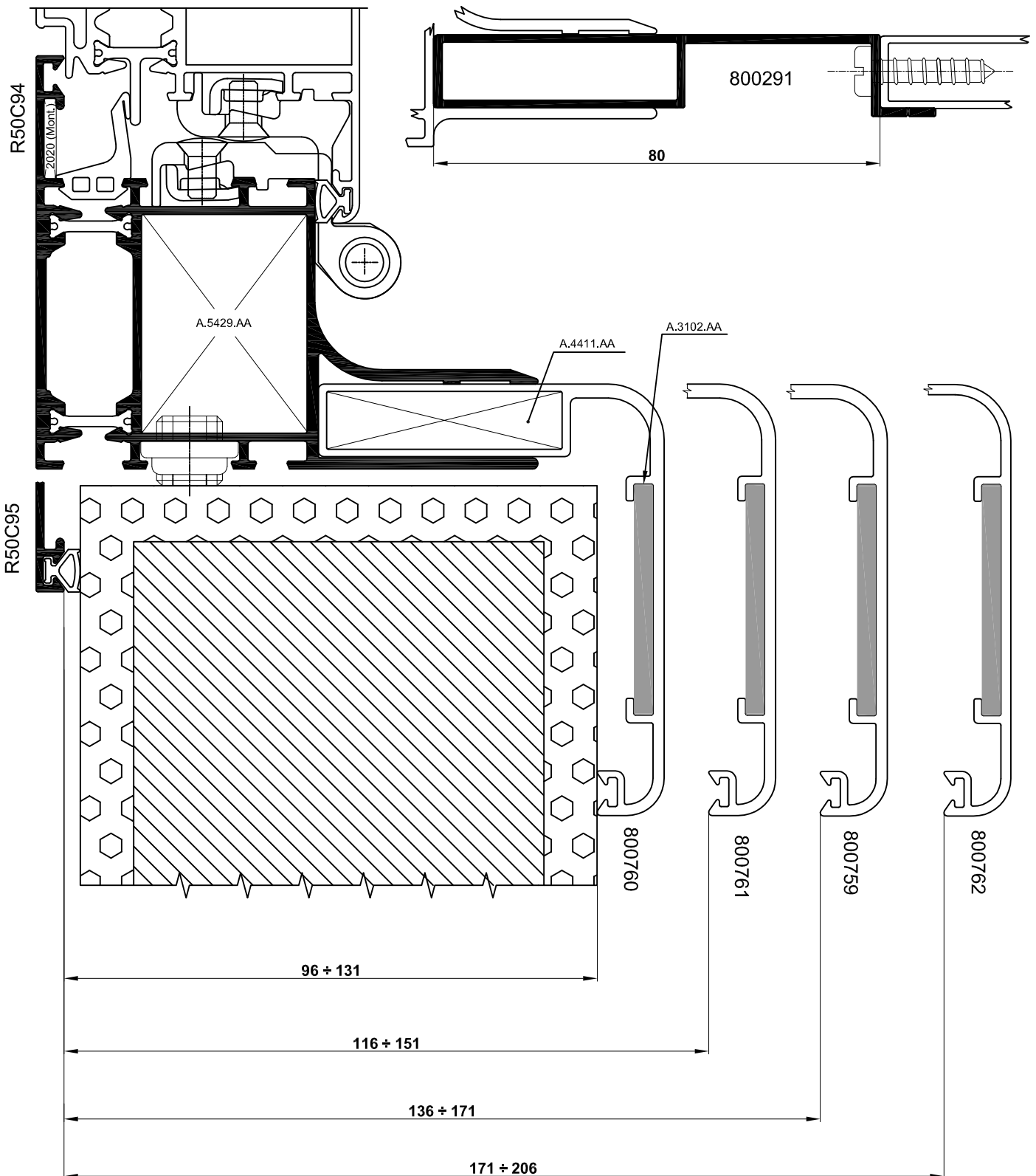

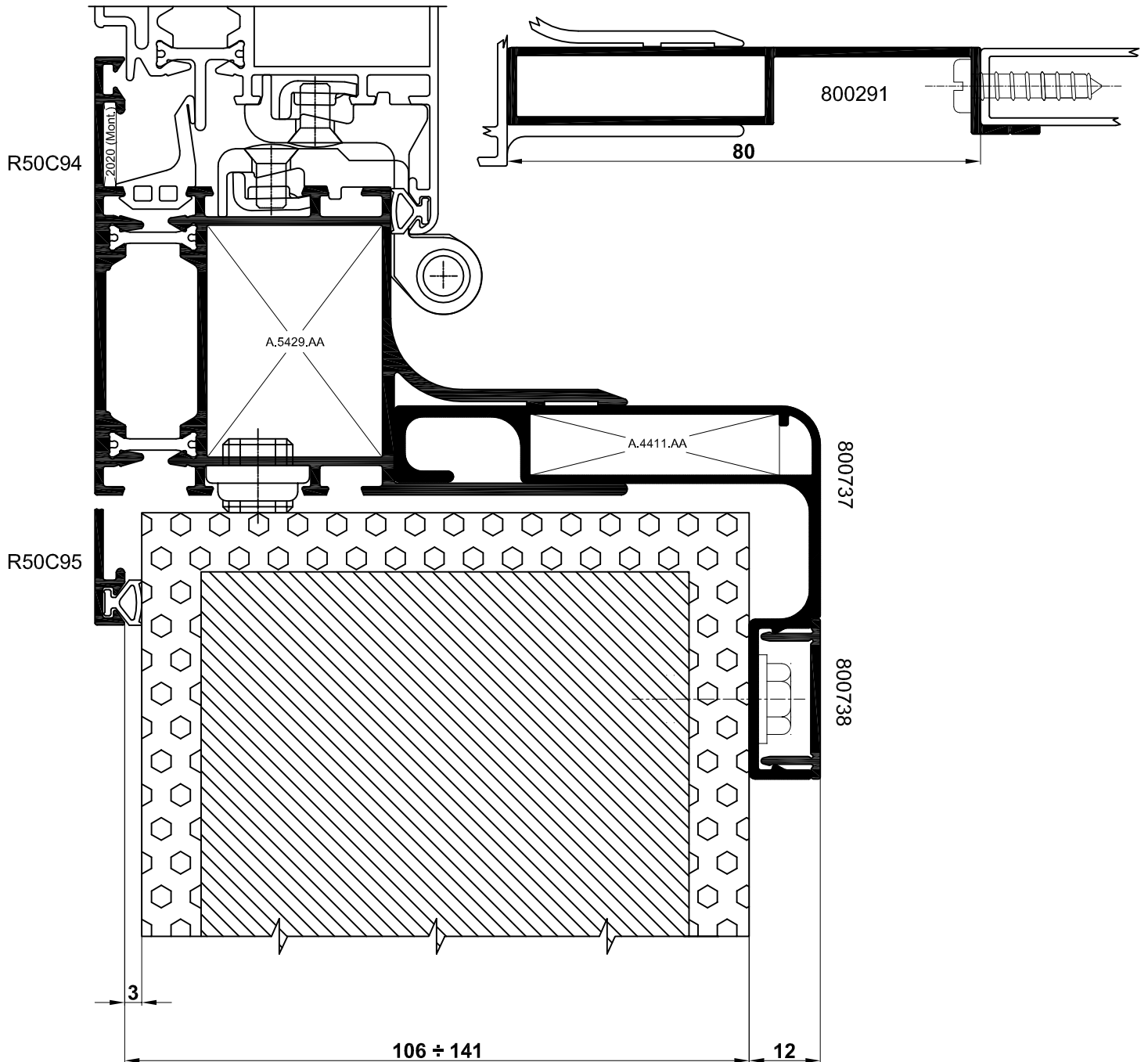

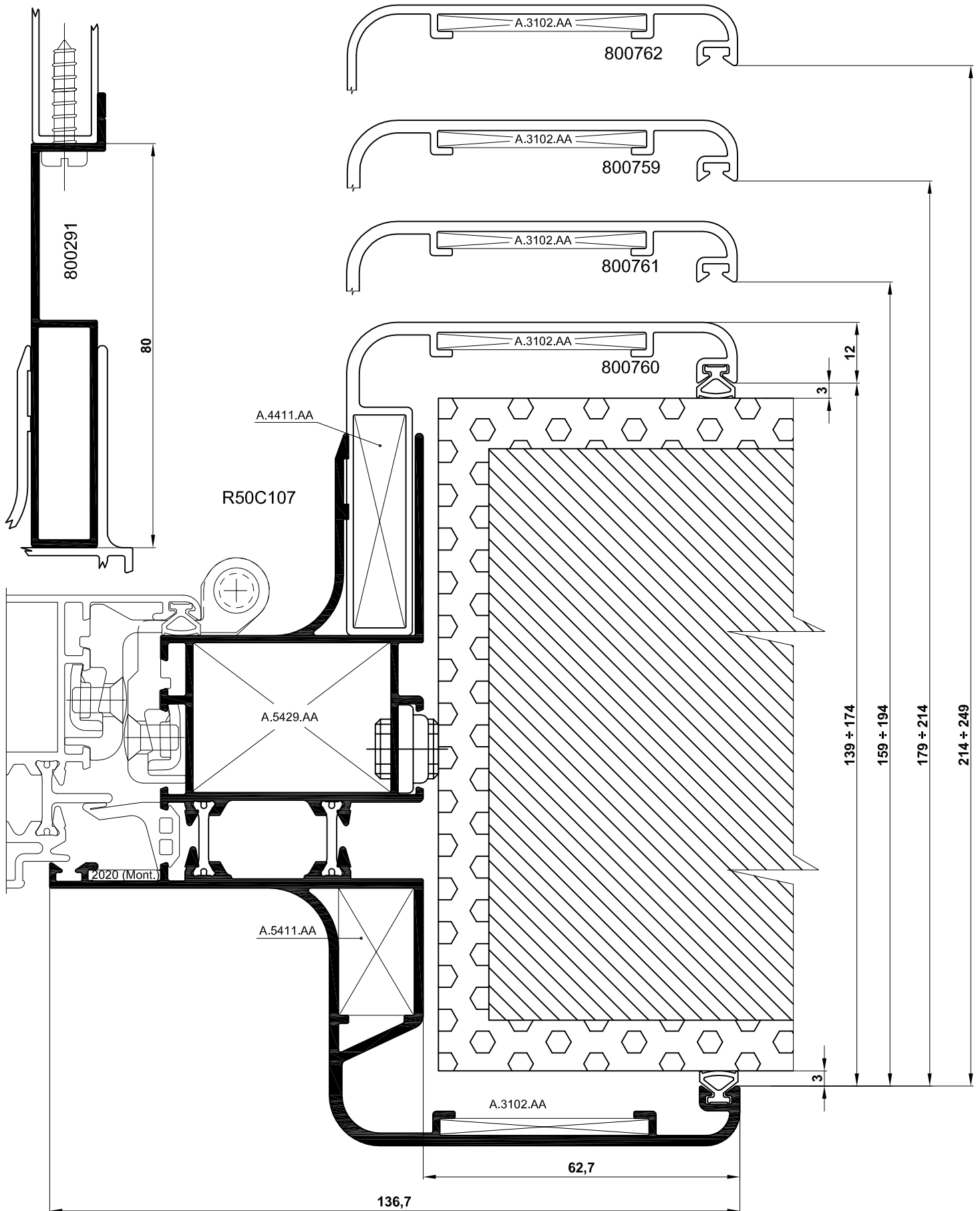

Profilati Sections		Spessore Muro Wall Thickness
Ester.	Inter.	mm
800760	800760	x= 151+217
800760	800761	x= 171+237
800760	800759	x= 205+255
800760	800762	x= 226+292
800761	800760	x= 171+229
800761	800761	x= 191+257
800761	800759	x= 225+275
800761	800762	x= 246+312
800759	800760	x= 205+255
800759	800761	x= 225+275
800759	800759	x= 260+295
800759	800762	x= 280+330
800762	800760	x= 226+292
800762	800761	x= 246+314
800762	800759	x= 280+330
800762	800762	x= 301+367

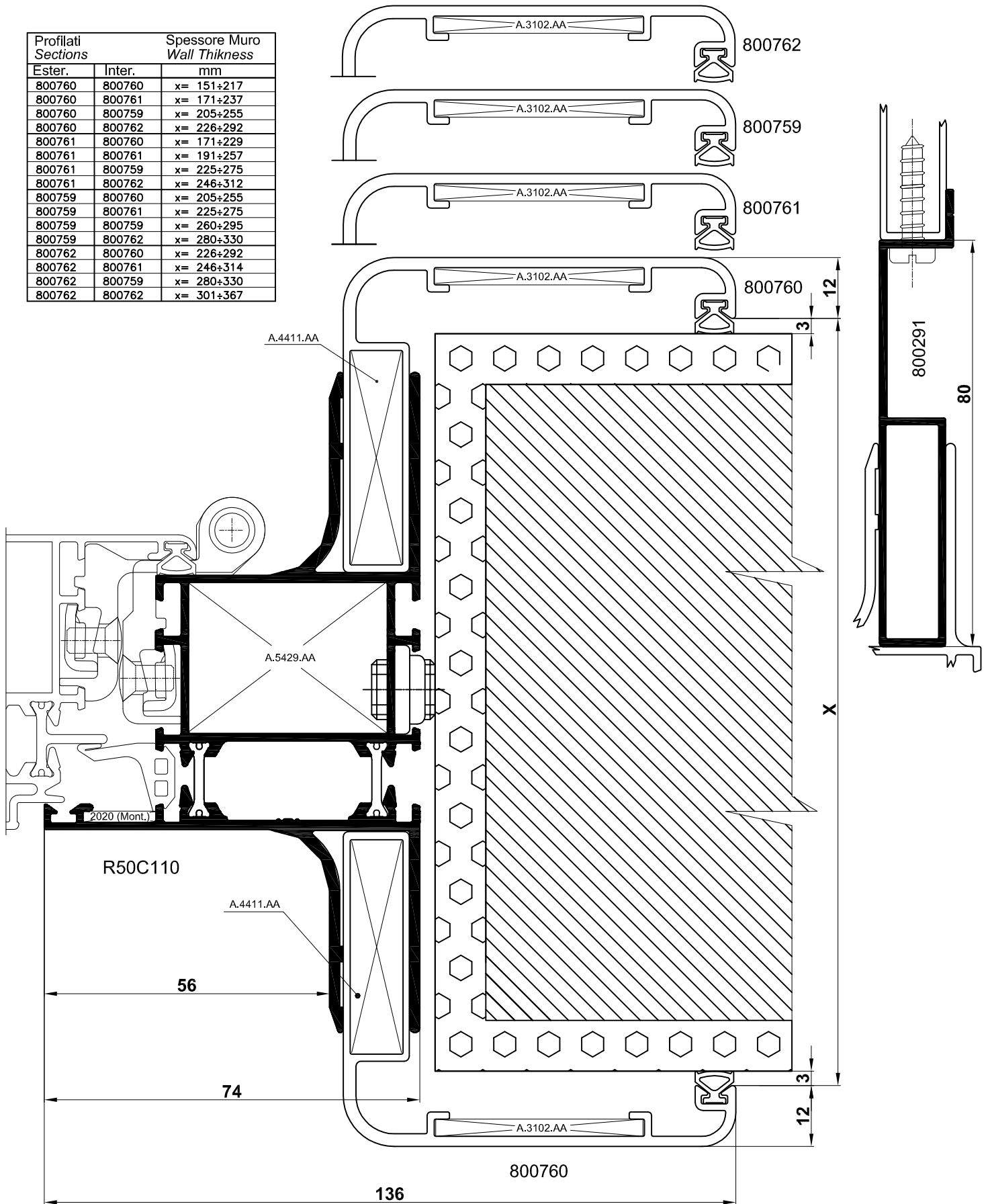

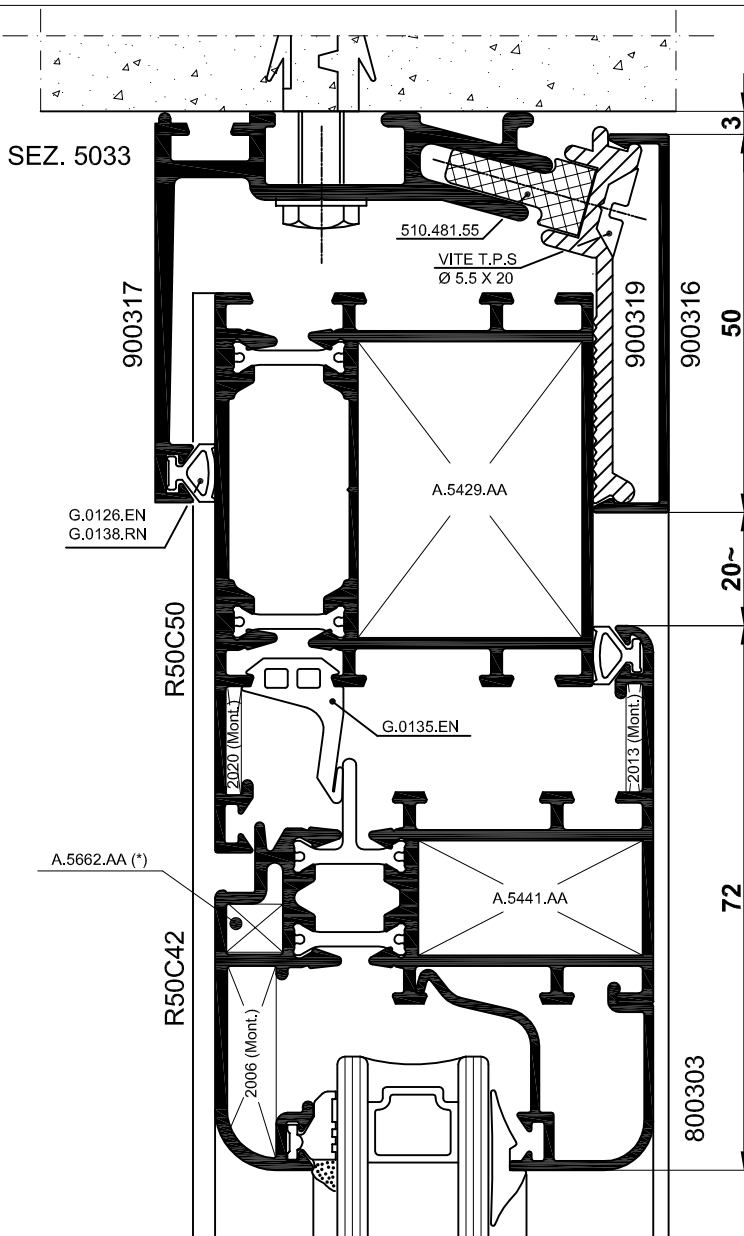
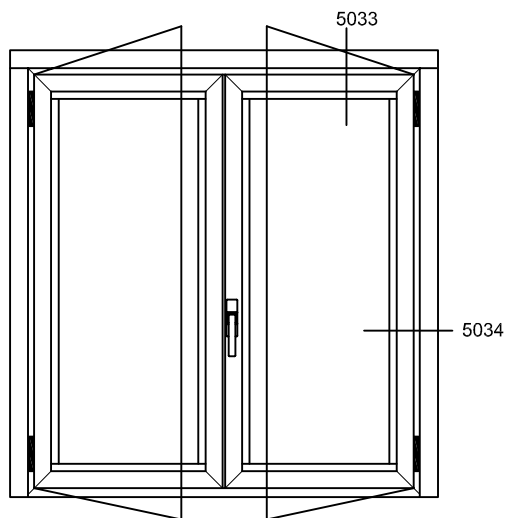

(*) Negli angoli a 45° le squadrette inserite nel tubolare esterno devono essere sempre incollate e cianfrinate.
 Cianfrinatura eseguibile anche con attrezzatura manuale Cod. M.2001.OO
In the 45° corners, the corner joints in the external tubular section, must always be glued and caulked. Caulking may also be carried out by hand with equipment Art.M.2001.OO

SEZ. 5034

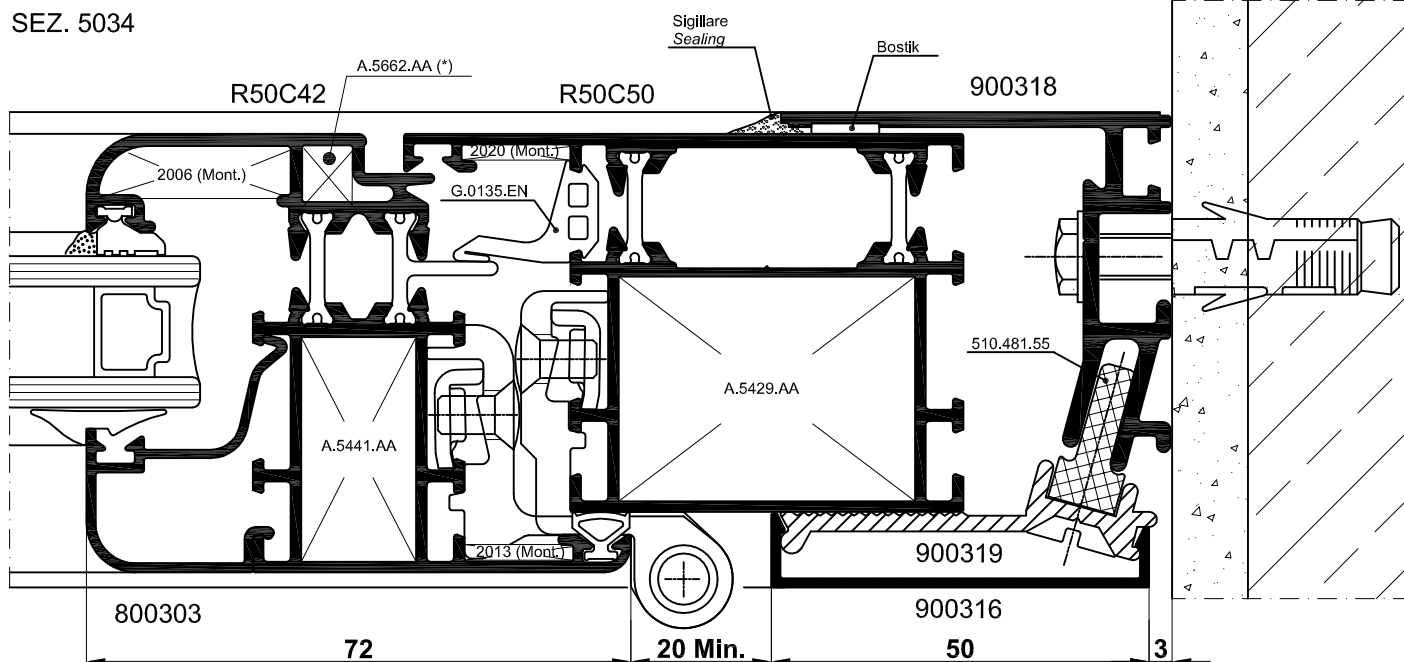

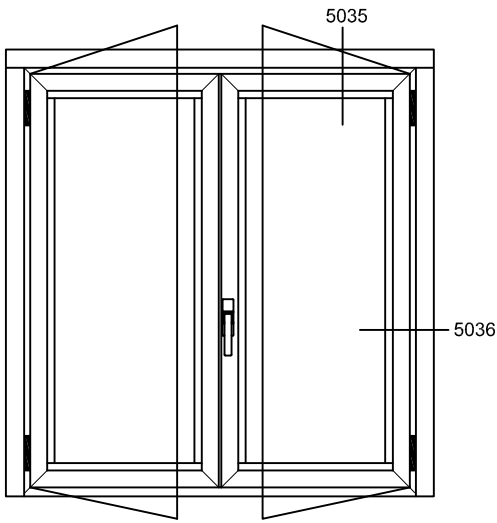

SEZ. 5035

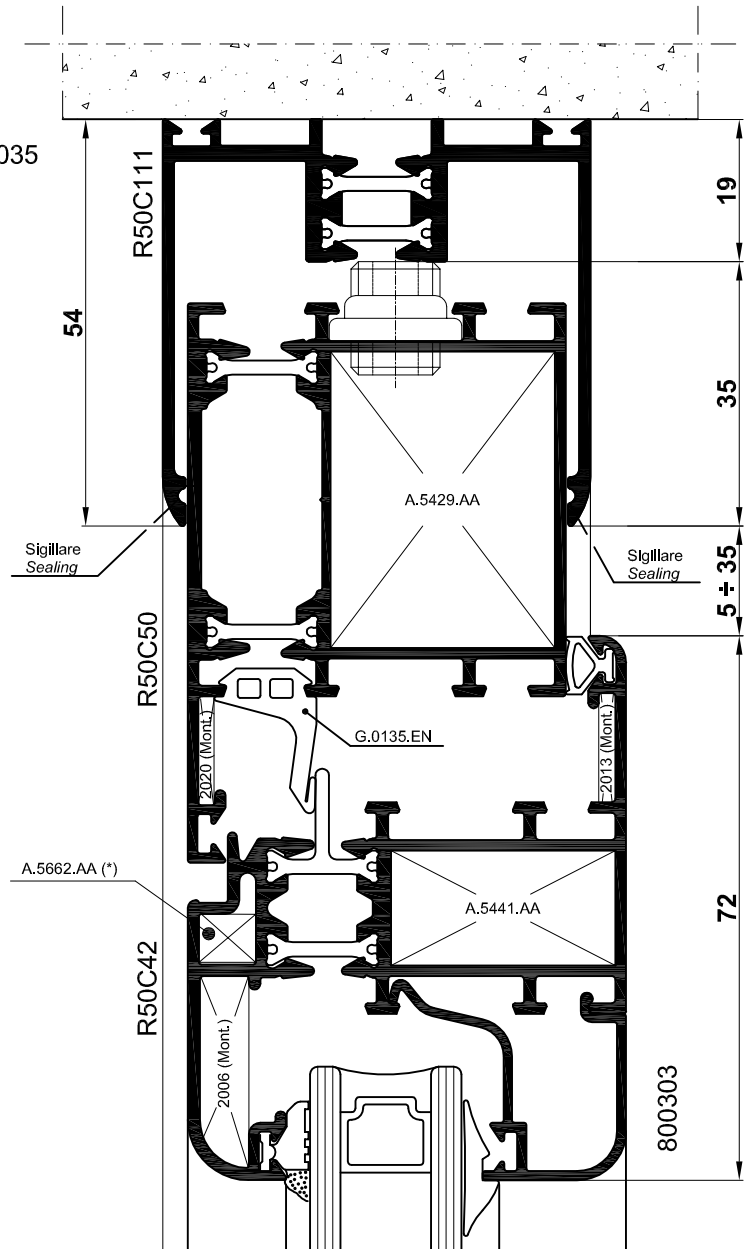

(*) Negli angoli a 45° le squadrette inserite nel tubolare esterno devono essere sempre incollate e cianfrinate. Cianfrinatura eseguibile anche con attrezzatura manuale Cod. M.2001.OO
 In the 45° corners, the corner joints in the external tubular section, must always be glued and caulked. Caulking may also be carried out by hand with equipment Art.M.2001.OO

SEZ. 5036

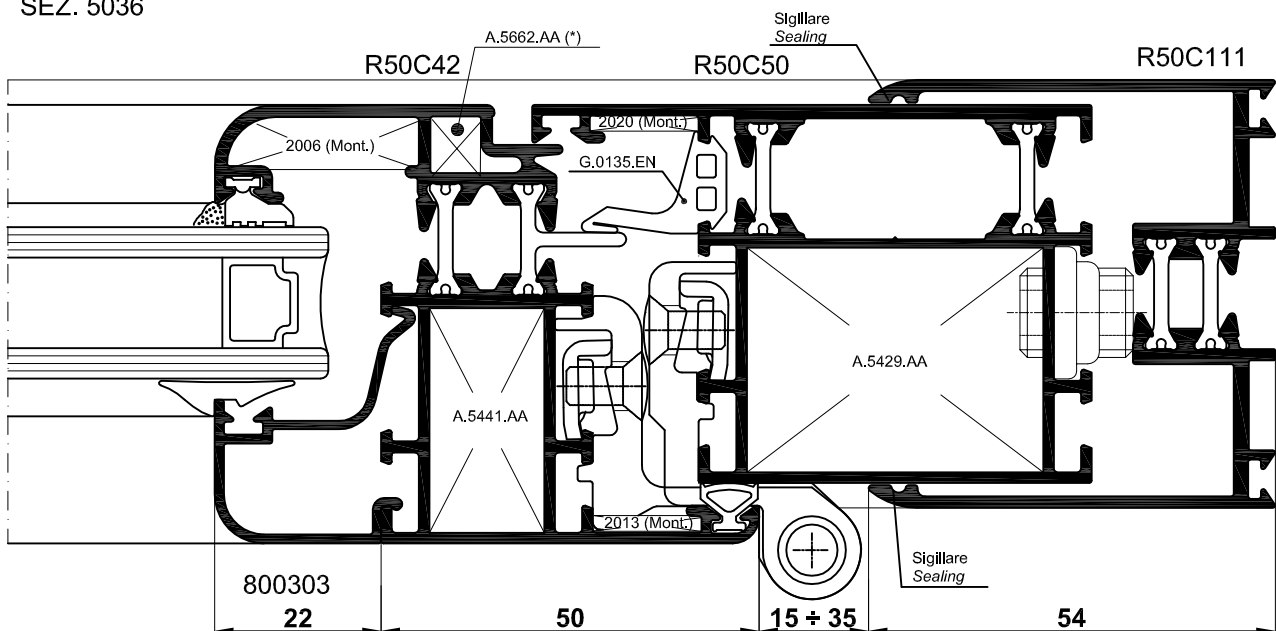

FINESTRA 1 ANTA
ONE-WING WINDOW

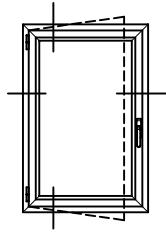

N.B: - Le dimensioni di taglio e di lavorazione indicate nelle pagine seguenti sono state ottenute considerando le quote teoriche.
Pertanto è necessario verificare sempre le dimensioni dei profilati prima di effettuare i tagli.
Sapa declina ogni responsabilità per errori dovuti al mancato controllo da parte del costruttore.

N.B: - The cutting and processing dimensions, indicated in the following pages, are obtained considering theoretical values.
It is, therefore, always necessary to check the dimensions of the profiles before executing the cutting.
Sapa declines any responsibility from errors caused from the missing dimensional check of the carpenter

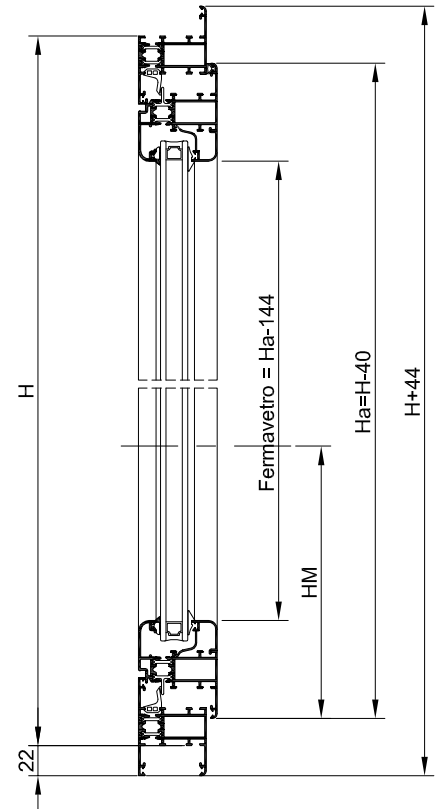
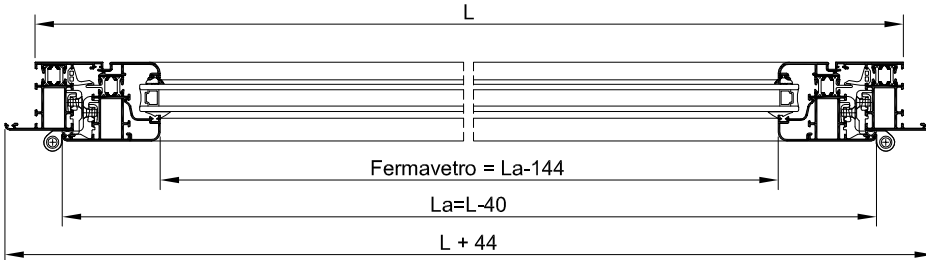

PROFILATI
SECTIONS

Profilato tipo Type Section	N° Pz.	Taglio Cut	N° Pz.	Taglio Cut
	2	H + 44	1	L + 44
			1	L + 44
	2	Ha= H - 40	2	La= L - 40
	2	Ha - 144	2	La - 144
	1	(Inferiore/Lower) Hm - 131	1	(Supertore/Upper) Ha - Hm - 131

DIMENSIONI VETRO
GLASS SIZE

N. 1 PEZZO	N.B.: Spessore vetro considerato 20 mm (4+12+4) Gioco perimetrale tra profilato e vetro 5 mm For glass with 20 mm thickness Space between glass and profile 5 mm
Ha - 110	
La - 110	

ACCESSORI
ACCESSORIES

Articolo Item	Descrizione Description	N	Articolo Item	Descrizione Description	N	Articolo Item	Descrizione Description	N
A.3501.TA	Innesti per cremonese su prof. 900221(cp) Nylon pair of coupling internal opening for 900221	1	A.5662.AA	Squadretta a cianfrinare su prof. est. anta External corner joint to be crimped	4	510.415.01	Regolo mobile da 15 mm Adjustable block mm 15	5
404.145.05	Puntali in zama su prof. 900221 (cp) Pair of zamak terminals on profile 900221	1	401.002.XX	Cerniera sfilabile con contop.rra in acc. inox Slip-of hinge with stainless steel counterplate	2	510.491.55	Tappo rotondo copriforo diametro 12 mm Circular coverhole plug dia. mm 12	5
2020(Mont.)	Squadretta Fuji allineamento aletta Fuji alignment corner joint on fin.	4	A.4003.ZX	Cremonese reversibile per ap. int. Reversible cremone bolt for internal opening	1	A.0228.EN	Angolo stampato per precamera R50TT-R72TT-R72TT1.3 Moulded corner for central weatherstrip R50TT-R72TT-R72TT1.3	4
2013(Mont.)	Squadretta Fuji allineamento aletta Fuji alignment corner joint on fin.	8	504.091.05	Riscontro registrabile per puntali 404.145.05 Adjustable striker for terminals 404.145.05	2	502.002.XX	Angolo stampato per fermavetro arrotondato Moulded corner for snap-on rounded glass beading	4
2006(Mont)	Squadretta Fuji all.mento aletta prof. compl. Fuji alignment corner joint for coplanar profiles	4	509.261.55	Cappetta scarico acqua (paratempesta) Water drain cover of nylon	2			
A.5441.AA	Squadretta per giunzione d'angolo Corner joint	8	410.405.01	Basetta unificata per regolo mobile Unified plate for adjustable block	5			

GUARNIZIONI
WEATHERSTRIPS

Articolo Item	Descrizione Description	N	Articolo Item	Descrizione Description	N	Articolo Item	Descrizione Description	N
G.0126.EN	Guarnizione di battuta Weatherstrip of rabbet	4H 3L	G.0139.RN	Guarnizione esterna appoggio vetri 1,5 mm Weatherstrip on glass support mm 1.5	2H 2L			
G.0129.EN	Guarnizione interna tenuta vetro 5-6 mm Weatherstrip on glazing bead shim mm 5-6	2H 2L	G.0135.EN	Guarnizione di precamera R50TT - R72TT - R72TT1.3 Central weatherstrip R50TT- R72TT - R72TT1.3	2H 2L			

FINESTRA 2 ANTE
TWO-WINGS WINDOW

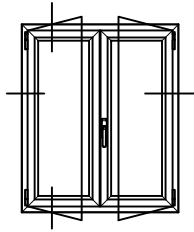

N.B: - Le dimensioni di taglio e di lavorazione indicate nelle pagine seguenti sono state ottenute considerando le quote teoriche.
Pertanto è necessario verificare sempre le dimensioni dei profilati prima di effettuare i tagli.
Sapa declina ogni responsabilità per errori dovuti al mancato controllo da parte del costruttore.

N.B: - The cutting and processing dimensions, indicated in the following pages, are obtained considering theoretical values.
It is, therefore, always necessary to check the dimensions of the profiles before executing the cutting.
Sapa declines any responsibility from errors caused from the missing dimensional check of the carpenter

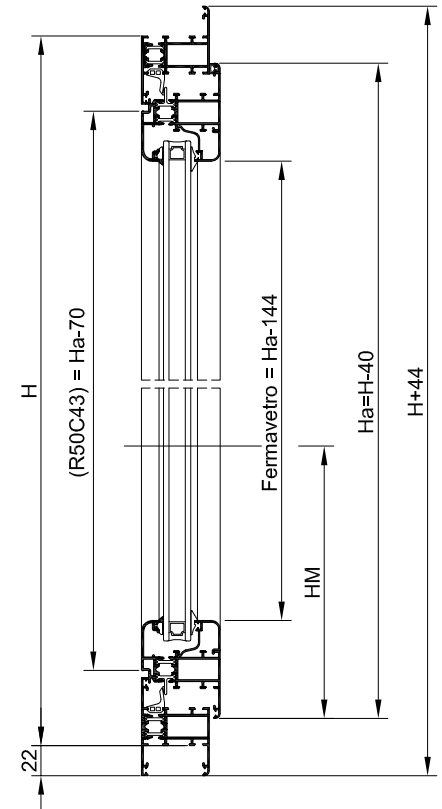
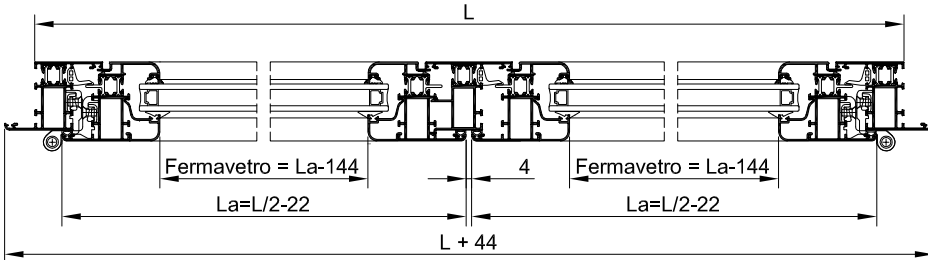

PROFILATI
SECTIONS

Profilato tipo Type Section	N° Pz.	Taglio Cut	N° Pz.	Taglio Cut
	2	H + 44	1	L + 44
			1	L + 44
	4	Ha = H - 40	4	La = L/2 - 22
	4	Ha - 144	4	La - 144
	1	Ha - 70		
	1	(Inferiore/Lower) Hm -131	1	(Superiore/Upper) Ha - Hm - 131

DIMENSIONI VETRO
GLASS SIZE

N. 2 PEZZI N.B.: Spessore vetro considerato 20 mm (4+12+4)
Gioco perimetrale tra profilato e vetro 5 mm
For glass with 20 mm thickness
Space between glass and profile 5 mm

Ha - 110
La - 110

ACCESSORI
ACCESSORIES

Articolo Item	Descrizione Description	N	Articolo Item	Descrizione Description	N	Articolo Item	Descrizione Description	N
A.3501.TA	Innesti per cremonese su prof. 900221(cp) Nylon pair of coupling internal opening for 900221	1	A.5662.AA	Squadretta a cianfrinare su prof. est. anta External corner joint to be crimped	8	502.002.XX	Angolo stampato per fermavetro arrotondato Moulded corner for snap-on rounded glass beading	8
404.145.05	Puntali in zama su prof. 900221 (cp) Pair of zamak terminals on profile 900221	2	401.002.XX	Cerniera sfilabile con contop.rra in acc. inox Slip-of hinge with stainless steel counterplate	4	509.261.55	Cappetta scarico acqua (paratempsta) Water drain cover of nylon	2
2020(Mont.)	Squadretta Fuji allineamento aletta Fuji alignment corner joint on fin.	4	A.4003.ZX	Cremonese reversibile per ap. int. Reversible cremone bolt for internal opening	1	410.405.01	Basetta unificata per regolo mobile Unified plate for adjustable block	5
2013(Mont.)	Squadretta Fuji allineamento aletta Fuji alignment corner joint on fin.	12	504.091.05	Riscontro registrabile per puntali 404.145.05 Adjustable striker for terminals 404.145.05	2	510.415.01	Regolo mobile da 15 mm Adjustable block mm 15	5
2006(Mont)	Squadretta Fuji all.mento aletta prof. compl. Fuji alignment corner joint for coplanar profiles	8	A.2129.TN	Coppia tappi per riporto centrale R50C43 Pair of plugs for central rabbet on profile R50C43	1	510.491.55	Tappo rotondo copriforo diametro 12 mm Circular coverhole plug dia. mm 12	5
A.5441.AA	Squadretta per giunzione d'angolo Corner joint	12	403.806.05	Manovra catenaccio per puntali 404.145.55 Lever deadlatch for terminals 404.145.55	2	A.0228.EN	Angolo stampato per precamera R50TT-R72TT-R72TT1.3 Moulded corner for central weatherstrip R50TT-R72TT-R72TT1.3	4

GUARNIZIONI
WEATHERSTRIPS

Articolo Item	Descrizione Description	N	Articolo Item	Descrizione Description	N	Articolo Item	Descrizione Description
G.0126.EN	Guarnizione di battuta Weatherstrip of rabbet	6H 3L	G.0139.RN	Guarnizione esterna appoggio vetri 1,5 mm Weatherstrip on glass support mm 1.5	4H 2L		
G.0129.EN	Guarnizione interna tenuta vetro 5-6 mm Weatherstrip on glazing bead shim mm 5-6	4H 2L	G.0135.EN	Guarnizione di precamera R50TT - R72TT - R72TT1.3 Central weatherstrip R50TT- R72TT - R72TT1.3	3H 2L		

FINESTRA 1 ANTA A RIBALTA
TILT AND TURN WINDOW

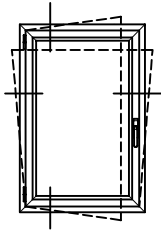

N.B: - Le dimensioni di taglio e di lavorazione indicate nelle pagine seguenti sono state ottenute considerando le quote teoriche.
Pertanto è necessario verificare sempre le dimensioni dei profilati prima di effettuare i tagli.
Sapa declina ogni responsabilità per errori dovuti al mancato controllo da parte del costruttore.

N.B: - The cutting and processing dimensions, indicated in the following pages, are obtained considering theoretical values.
It is, therefore, always necessary to check the dimensions of the profiles before executing the cutting.
Sapa declines any responsibility from errors caused from the missing dimensional check of the carpenter

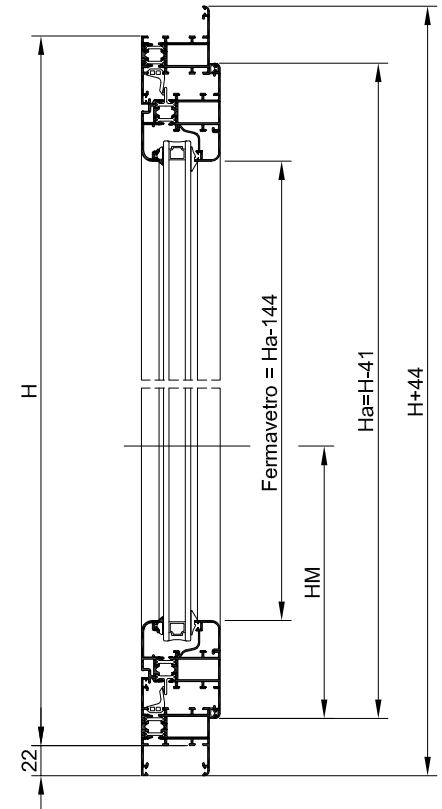
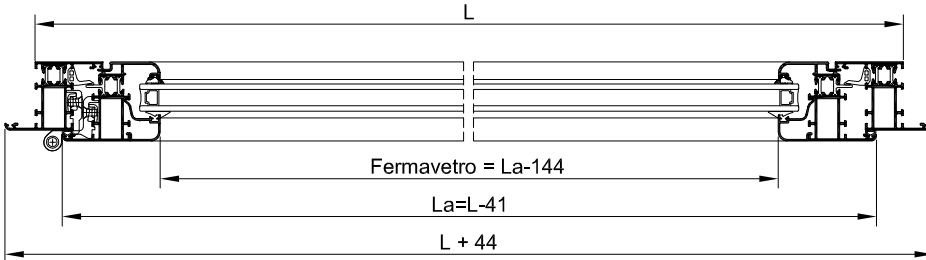

PROFILATI
SECTIONS

Profilato tipo Type Section	N° Pz.	Taglio Cut	N° Pz.	Taglio Cut
	2	H + 44	1	L + 44
			1	L + 44
	2	Ha = H - 41	2	La = L - 41
	2	Ha - 144	2	La - 144
	1	Verticale inferiore Lower Vertical Hm - 250 (*)	1	Verticale Superiore Upper Vertical Ha - Hm - 243 (*)
			1	Orizzontale Superiore Upper Horizontal La - 515 (*)

DIMENSIONI VETRO
GLASS SIZE

N. 1 PEZZO	N.B.: Spessore vetro considerato 20 mm (4+12+4) Gioco perimetrale tra profilato e vetro 5 mm For glass with 20 mm thickness Space between glass and profile 5 mm
Ha - 110	
La - 110	

(*) = Valido per ante con La da 550 a 1200 mm ed Ha fino a 2800 mm. Per altre dimensioni ed ulteriori informazioni Vi preghiamo di consultare lo schema di montaggio contenuto nella confezione AR.
This for wings with L from 550 to 1200 mm and H up to 2800 mm. For other dimensions and further information please see processing scheme inside AR box

Attenzione: in corrispondenza dei cardini inferiore e superiore utilizzare squadretta A.2919.NN invece della 2013 (Mont.)
Attention: in correspondence of the bottom and upper hinges, use corner joint A.2919.NN instead of 2013 (Mont.)

ACCESSORI
ACCESSORIES

Articolo Item	Descrizione Description	N	Articolo Item	Descrizione Description	N	Articolo Item	Descrizione Description	N
A. 1805.VX	Gruppo completo anta ribalta Tilt-and-turn kit	1	A.5662.AA	Squadretta a cianfrinare su prof. est. anta External corner joint to be crimped	4	502.002.XX	Angolo stampato per fermavetro arrotondato Moulded corner for snap-on rounded glass beading	4
2020(Mont.)	Squadretta Fuji allineamento aletta Fuji alignment corner joint on fin.	4	509.261.55	Cappetta scarico acqua (paratempsta) Water drain cover of nylon	2			
2013(Mont.)	Squadretta Fuji allineamento aletta Fuji alignment corner joint on fin.	6	410.405.01	Basetta unificata per regolo mobile Unified plate for adjustable block	5			
A.2919.NN	Squadretta allineamento aletta alignment corner joint on fin.	2	510.415.01	Regolo mobile da 15 mm Adjustable block mm 15	5			
2006(Mont)	Squadretta Fuji all.mento aletta prof. compl. Fuji alignment corner joint for coplanar profiles	4	510.491.55	Tappo rotondo copriforo diametro 12 mm Circular coverhole plug dia. mm 12	5			
A.5441.AA	Squadretta per giunzione d'angolo Corner joint	8	A.0228.EN	Angolo stampato per precamera R50TT - R72TT - R72TT1.3 Moulded corner for central weatherstrip R50TT - R72TT - R72TT1.3	4			

GUARNIZIONI
WEATHERSTRIPS

Articolo Item	Descrizione Description	N	Articolo Item	Descrizione Description	N	Articolo Item	Descrizione Description	N
G.0126.EN	Guarnizione di battuta Weatherstrip of rabbet	4H 3L	G.0139.RN	Guarnizione esterna appoggio vetri 1,5 mm Weatherstrip on glass support mm 1.5	2H 2L			
G.0129.EN	Guarnizione interna tenuta vetro 5-6 mm Weatherstrip on glazing bead shim mm 5-6	2H 2L	G.0135.EN	Guarnizione di precamera R50TT - R72TT - R72TT1.3 Central weatherstrip R50TT - R72TT - R72TT1.3	2H 2L			

FINESTRA 2 ANTE
CON ANTA RIBALTA
WING WINDOW - OVERLAP
AND TILT-AND-TURN

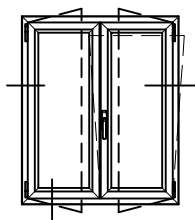

N.B.: - Le dimensioni di taglio e di lavorazione indicate nelle pagine seguenti sono state ottenute considerando le quote teoriche.
Pertanto è necessario verificare sempre le dimensioni dei profilati prima di effettuare i tagli.
Sapa declina ogni responsabilità per errori dovuti al mancato controllo da parte del costruttore.

N.B.: - The cutting and processing dimensions, indicated in the following pages, are obtained considering theoretical values.
It is, therefore, always necessary to check the dimensions of the profiles before executing the cutting.
Sapa declines any responsibility from errors caused from the missing dimensional check of the carpenter

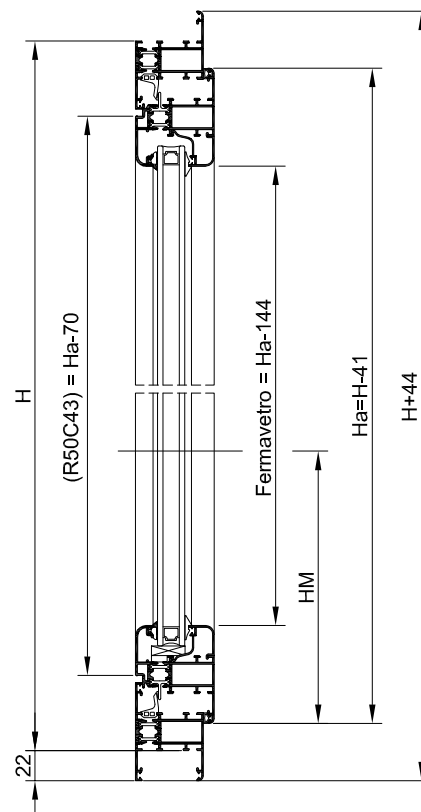
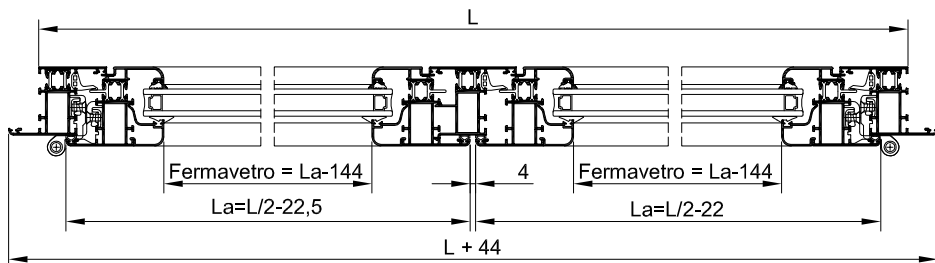

PROFILATI
SECTIONS

Profilato tipo Type Section	N° Pz.	Taglio Cut	N° Pz.	Taglio Cut
	2	H + 44	1	L + 44
	1		1	L + 44
	4	Ha = H - 41	4	La = L/2 - 22,5
	4	Ha - 144	4	La - 144
	1	Ha - 70		
	1	Verticale inferiore Lower Vertical Hm - 250 (*)	1	Verticale Superiore Upper Vertical Ha - Hm - 243 (*)
			1	Orizzontale Superiore Upper Orizzontale La - 515 (*)

(*) = Valido per ante con La da 550 a 1200 mm ed Ha fino a 2800 mm. Per altre dimensioni ed ulteriori informazioni Vi preghiamo di consultare lo schema di montaggio contenuto nella confezione AR.

This for wings with L from 550 to 1200 mm and H up to 2800 mm. For other dimensions and further information please see processing scheme inside A/R box

Attenzione: in corrispondenza dei cardini inferiori e superiori utilizzare squadretta A.2919.NN invece della 2013 (Mont.)
Attention: in corrispondence of the bottom and upper hinges, use corner joint A.2919.NN instead of 2013 (Mont.)

DIMENSIONI VETRO
GLASS SIZE

N. 2 PEZZI	N.B.: Spessore vetro considerato 20 mm (4+12+4) Gioco perimetrale tra profilato e vetro 5 mm For glass with 20 mm thickness Space between glass and profile 5 mm
Ha - 110	
La - 110	

ACCESSORI
ACCESSORIES

Articolo Item	Descrizione Description	N	Articolo Item	Descrizione Description	N	Articolo Item	Descrizione Description	N
A.1805.VX	Gruppo completo anta ribalta Tilt-and-turn kit	1	A.2919.NN	Squadretta allineamento aletta Alignment corner joint on fin.	4	410.405.01	Basetta unificata per regolo mobile Unified plate for adjustable block	5
A.1810.VV	Paletti per anta semifissa A/R (cp) Straight latches for semifixed wing (pair)	1	2006(Mont.)	Squadretta Fuji all.mento aletta prof. compl. Fuji alignment corner joint for coplanar profiles	8	510.415.01	Regolo mobile da 15 mm Adjustable block mm 15	5
A.1805.VX	Kit cerniere anta affiancata A/R Kit hinges for semifixed wing	1	A.5662.AA	Squadretta a cianfrinare su prof. est. anta External corner joint to be crimped	8	510.491.55	Tappo rotondo copriforo diametro 12 mm Circular coverhole plug dia. mm 12	5
2020(Mont.)	Squadretta Fuji allineamento aletta Fuji alignment corner joint on fin.	4	A.5441.AA	Squadretta per giunzione d'angolo Corner joint	12	A.0228.EN	Angolo stampato per precamera R50TT-R72TT-R72TT1.3 Moulded corner for prechamber R50TT-R72TT-R72TT1.3	4
2013(Mont.)	Squadretta Fuji allineamento aletta Fuji alignment corner joint on fin.	8	A.2129.TN	Coppia tappi per riporto centrale R50C43 Pair of plugs for central rabbet on profile R50C43	1	502.002.XX	Angolo stampato per fermavetro arrotondato Moulded corner for snap-on rounded glass beading	8
			509.261.55	Cappetta scarico acqua (paratempesta) Water drain cover of nylon	2			

GUARNIZIONI
WEATHERSTRIPS

Articolo Item	Descrizione Description	N	Articolo Item	Descrizione Description	N	Articolo Item	Descrizione Description
G.0126.EN	Guarnizione di battuta Weatherstrip of rabbet	6H 3L	G.0139.RN	Guarnizione esterna appoggio vetri 1,5 mm Weatherstrip on glass support mm 1.5	4H 2L		
G.0129.EN	Guarnizione interna tenuta vetro 5-6 mm Weatherstrip on glazing bead shim mm 5-6	4H 2L	G.0135.EN	Guarnizione di precamera R50TT - R72TT - R72TT1.3 Central weatherstrip R50TT - R72TT - R72TT1.3	3H 2L		

FINESTRA SPORGERE
PROJECTING WINDOW

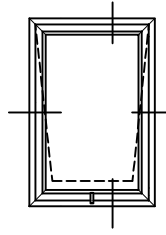

N.B: - Le dimensioni di taglio e di lavorazione indicate nelle pagine seguenti sono state ottenute considerando le quote teoriche.
Pertanto è necessario verificare sempre le dimensioni dei profilati prima di effettuare i tagli.
Sapa declina ogni responsabilità per errori dovuti al mancato controllo da parte del costruttore.

N.B: - The cutting and processing dimensions, indicated in the following pages, are obtained considering theoretical values.
It is, therefore, always necessary to check the dimensions of the profiles before executing the cutting.
Sapa declines any responsibility from errors caused from the missing dimensional check of the carpenter

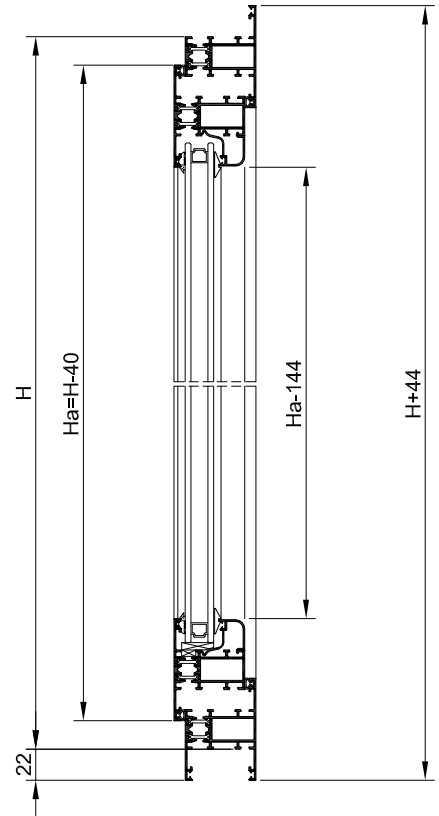
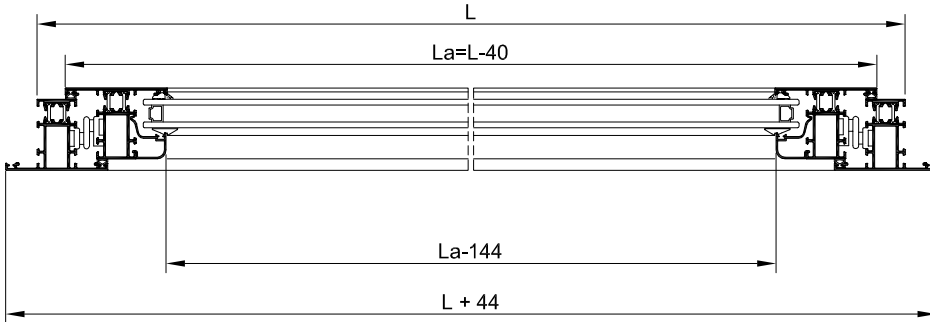

PROFILATI
SECTIONS

Profilato tipo Type Section	N° Pz.	Taglio Cut	N° Pz.	Taglio Cut
	2	 H + 44	1	 L + 44
			1	 L + 44
	2	 Ha= H - 40	2	 La= L - 40
	2	 Ha - 144	2	 La - 144

DIMENSIONI VETRO
GLASS SIZE

N. 1 PEZZO	N.B.: Spessore vetro considerato 20 mm (4+12+4) Gioco perimetrale tra profilato e vetro 5 mm For glass with 20 mm thickness Space between glass and profile 5 mm
Ha - 110	
La - 110	

ACCESSORI
ACCESSORIES

Articolo Item	Descrizione Description	N	Articolo Item	Descrizione Description	N	Articolo Item	Descrizione Description	N
406.499.05	Gruppo articolazione sporgere con bracci Kit for stiffened projecting windows with arms	1	510.415.01	Regolo mobile da 15 mm Adjustable block mm 15	5			
503.963.xx	Maniglia a tavellino "linea 600" "600 flatcatch" handle for projecting windows	1	510.491.55	Tappo rotondo copriforo diametro 12 mm Circular coverhole plug dia. mm 12	5			
2020(Mont.)	Squadretta Fuji allineamento aletta Fuji alignment corner joint on fin.	8	502.002.XX	Angolo stampato per fermavetro arrotondato Moulded corner for snap-on rounded glass beading	4			
2013(Mont.)	Squadretta Fuji allineamento aletta Fuji alignment corner joint on fin.	8						
A.5441.AA	Squadretta per giunzione d'angolo Corner joint	8						
410.405.01	Basetta unificata per regolo mobile Unified plate for adjustable block	5						

GUARNIZIONI
WEATHERSTRIPS

Articolo Item	Descrizione Description	N	Articolo Item	Descrizione Description	N	Articolo Item	Descrizione Description	N
G.0126.EN	Guarnizione di battuta Weatherstrip of rabbet	6H 5L	G.0139.RN	Guarnizione esterna appoggio vetri 1,5 mm Weatherstrip on glass support mm 1.5	2H 2L			
G.0129.EN	Guarnizione interna tenuta vetro 5-6 mm Weatherstrip on glazing bead shim mm 5-6	2H 2L						

FINESTRA VASISTAS
OVERLAP HOPPER WINDOW

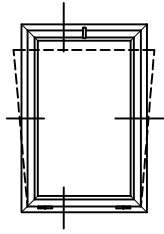

N.B: - Le dimensioni di taglio e di lavorazione indicate nelle pagine seguenti sono state ottenute considerando le quote teoriche.
Pertanto è necessario verificare sempre le dimensioni dei profilati prima di effettuare i tagli.
Sapa declina ogni responsabilità per errori dovuti al mancato controllo da parte del costruttore.

N.B: - The cutting and processing dimensions, indicated in the following pages, are obtained considering theoretical values.
It is, therefore, always necessary to check the dimensions of the profiles before executing the cutting.
Sapa declines any responsibility from errors caused from the missing dimensional check of the carpenter

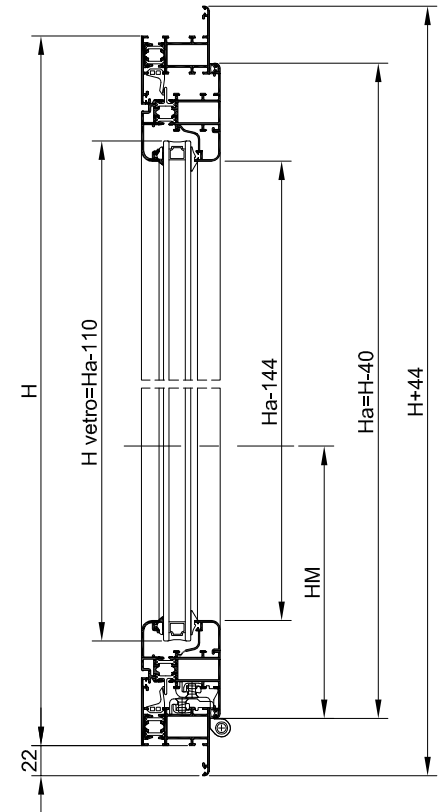
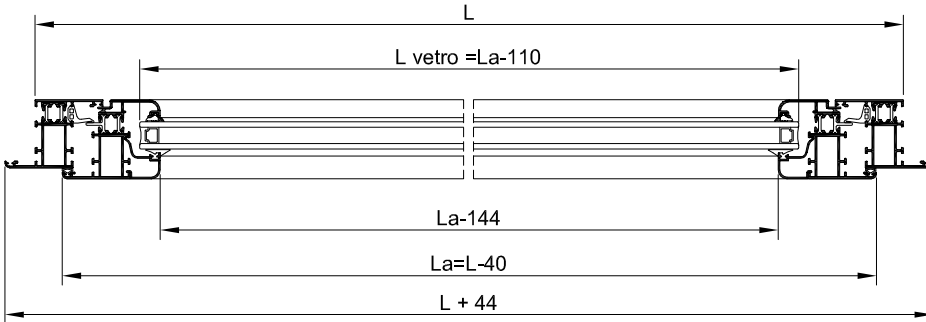

PROFILATI
SECTIONS

Profilato tipo Type Section	N° Pz.	Taglio Cut	N° Pz.	Taglio Cut
	2	 H + 44	2	 L + 44
	2	 Ha= H - 40	2	 La= L - 40
	2	 Ha - 144	2	 La - 144

DIMENSIONI VETRO
GLASS SIZE

N. 1 PEZZO	N.B.: Spessore vetro considerato 20 mm (4+12+4) Gioco perimetrale tra profilato e vetro 5 mm For glass with 20 mm thickness Space between glass and profile 5 mm
Ha - 110	
La - 110	

ACCESSORI
ACCESSORIES

Articolo Item	Descrizione Description	N	Articolo Item	Descrizione Description	N	Articolo Item	Descrizione Description	N
A.3906.IA	coppia bracci per vasistas Pair of arms for hopper windows	1	A.5441.AA	Squadretta per giunzione d'angolo Corner joint	8	502.002.XX	Angolo stampato per fermavetro arrotondato Moulded corner for snap-on rounded glass beading	4
401.002.xx	Cerniera sfilabile con controp.la in acc. inox Slip-of hinge with stainless steel counterplate	2	509.261.55	Cappetta scarico acqua (paratempesta) Water drain cover of nylon	2			
503.642.xx	Chiusura a cricchetto Spring latch locking	1	410.405.01	Basetta unificata per regolo mobile Unified plate for adjustable block	5			
2020(Mont.)	Squadretta Fuji allineamento aletta Fuji alignment corner joint on fin.	4	510.415.01	Regolo mobile da 15 mm Adjustable block mm 15	5			
2013(Mont.)	Squadretta Fuji allineamento aletta Fuji alignment corner joint on fin.	8	510.491.55	Tappo rotondo copriforo diametro 12 mm Circular coverhole plug dia. mm 12	5			
2006(Mont)	Squadretta Fuji all.mento aletta prof. compl. Fuji alignment corner joint for coplanar profiles	4	A.0228.EN	Angolo stampato per precamera R50TT-R72TT-R72TT1,3 Moulded corner for central weatherstrip R50TT-R72TT-R72TT1.3	4			

GUARNIZIONI
WEATHERSTRIPS

Articolo Item	Descrizione Description	N	Articolo Item	Descrizione Description	N	Articolo Item	Descrizione Description	N
G.0126.EN	Guarnizione di battuta Weatherstrip of rabbet	4H 3L	G.0139.RN	Guarnizione esterna appoggio vetri 1,5 mm Weatherstrip on glass support mm 1.5	2H 2L			
G.0129.EN	Guarnizione interna tenuta vetro 5-6 mm Weatherstrip on glazing bead shim mm 5-6	2H 2L	G.0135.EN	Guarnizione di precamera R50TT - R72TT - R72TT1,3 Central weatherstrip R50TT - R72TT - R72TT1.3	2H 2L			

PORTA
BALCONE 1 ANTA
ONE-WING
BALCONY DOOR

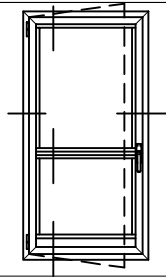

N.B: - Le dimensioni di taglio e di lavorazione indicate nelle pagine seguenti sono state ottenute considerando le quote teoriche.
Pertanto è necessario verificare sempre le dimensioni dei profilati prima di effettuare i tagli.
Sapa declina ogni responsabilità per errori dovuti al mancato controllo da parte del costruttore.

N.B: - The cutting and processing dimensions, indicated in the following pages, are obtained considering theoretical values.
It is, therefore, always necessary to check the dimensions of the profiles before executing the cutting.
Sapa declines any responsibility from errors caused from the missing dimensional check of the carpenter

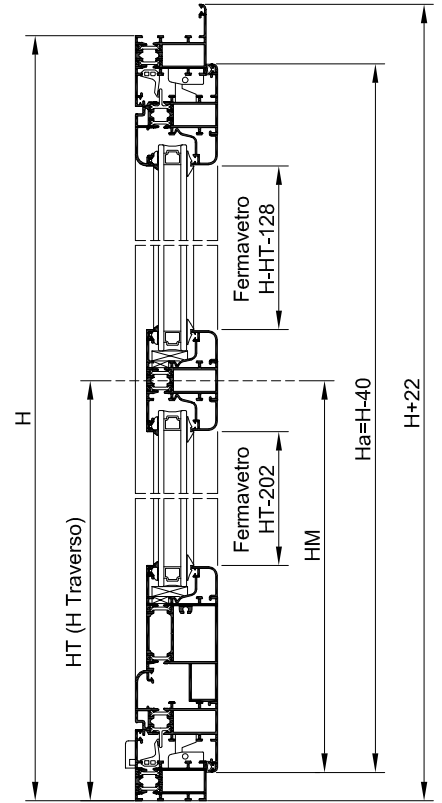
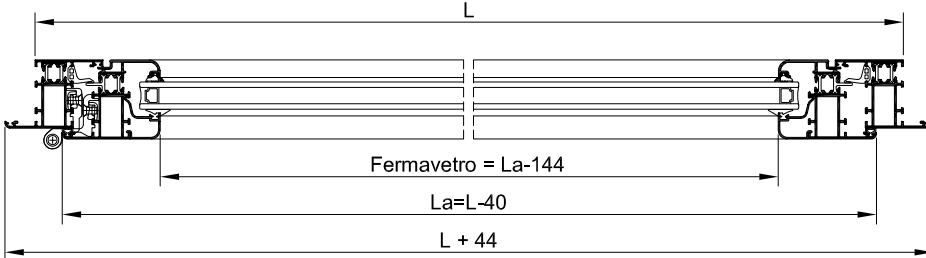

PROFILATI
SECTIONS

Profilato tipo Type Section	N° Pz.	Taglio Cut	N° Pz.	Taglio Cut
	1		1	
	1			
			1	
	2		2	
			1	
			1	
	2		2	
	1		1	
	2		4	
	1		1	

DIMENSIONE VETRO
GLASS SIZE

N. 1 PEZZO
HT - 168
La - 110

N. 1 PEZZO
H - HT - 94
La - 110

N.B.: Spessore vetro considerato 20 mm (4+12+4)
Gioco perimetrale tra profilato e vetro 5 mm
For glass with 20 mm thickness
Space between glass and profile 5 mm

ACCESSORI
ACCESSORIES

Articolo Item	Descrizione Description	N	Articolo Item	Descrizione Description	N	Articolo Item	Descrizione Description	N
A.3501.TA	Innesti per cremonese su prof. 900221(cp) Nylon pair of coupling internal opening for 900221	1	A.5662.AA	Squadretta a cianfrinare su prof. est. anta External corner joint to be crimped	4	510.415.01	Regolo mobile da 15 mm Adjustable block mm 15	8
404.145.05	Puntali in zama su prof. 900221 (cp) Pair of zamak terminals on profile 900221	1	505.267.01	Giunto a "T" in alluminio estruso Extruded aluminium T joint	2	510.491.55	Tappo rotondo copriforo diametro 12 mm Circular coverhole plug dia. mm 12	8
2020(Mont.)	Squadretta Fuji allineamento aletta Fuji alignment corner joint on fin.	4	A.4003.ZX	Cremonese reversibile per ap. int. Reversible cremone bolt for internal opening	1	A.0228.EN	Angolo stampato per precamera R50TT-R72TT-R72TT1.3 Moulded corner for central weatherstrip R50TT-R72TT-R72TT1.3	4
2013(Mont.)	Squadretta Fuji allineamento aletta Fuji alignment corner joint on fin.	6	504.091.05	Riscontro registrabile per puntali 404.145.05 Adjustable striker for terminals 404.145.05	2	502.002.XX	Angolo stampato per fermavetro arrotondato Moulded corner for snap-on rounded glass beading	8
2006(Mont.)	Squadretta Fuji allineamento aletta prof. compl. Fuji alignment corner joint for coplanar profiles	4	509.261.55	Cappetta scarico acqua (paratempesta) Water drain cover of nylon	2	401.002.XX	Cerniera sfilabile con controp. in acc. inox Slip-of hinge with stainless steel counterplate	3
A.5441.AA	Squadretta per giunzione d'angolo Corner joint	8	410.405.01	Basetta unificata per regolo mobile Unified plate for adjustable block	8	A.3204.ZA	Cavalotto di giunzione tela-traversi Tjoint for frames transoms	6

GUARNIZIONI
WEATHERSTRIPS

Articolo Item	Descrizione Description	N	Articolo Item	Descrizione Description	N	Articolo Item	Descrizione Description	N
G.0126.EN	Guarnizione di battuta Weatherstrip of rabbet	4H 3L	G.0139.RN	Guarnizione esterna appoggio vetri 1,5 mm Weatherstrip on glass support mm 1.5	2H 4L			
G.0129.EN	Guarnizione interna tenuta vetro 5-6 mm Weatherstrip on glazing bead shim mm 5-6	2H 4L	G.0135.EN	Guarnizione di precamera R50TT - R72TT - R72TT1.3 Central weatherstrip R50TT - R72TT - R72TT1.3	2H 2L			

PORTA
BALCONE 2 ANTE
TWO-WINGS
BALCONY DOOR

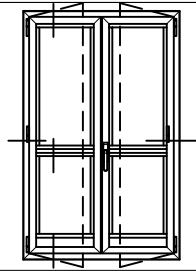

N.B: - Le dimensioni di taglio e di lavorazione indicate nelle pagine seguenti sono state ottenute considerando le quote teoriche.
Pertanto è necessario verificare sempre le dimensioni dei profilati prima di effettuare i tagli.
Sapa declina ogni responsabilità per errori dovuti al mancato controllo da parte del costruttore.

N.B: - The cutting and processing dimensions, indicated in the following pages, are obtained considering theoretical values.
It is, therefore, always necessary to check the dimensions of the profiles before executing the cutting.
Sapa declines any responsibility from errors caused from the missing dimensional check of the carpenter

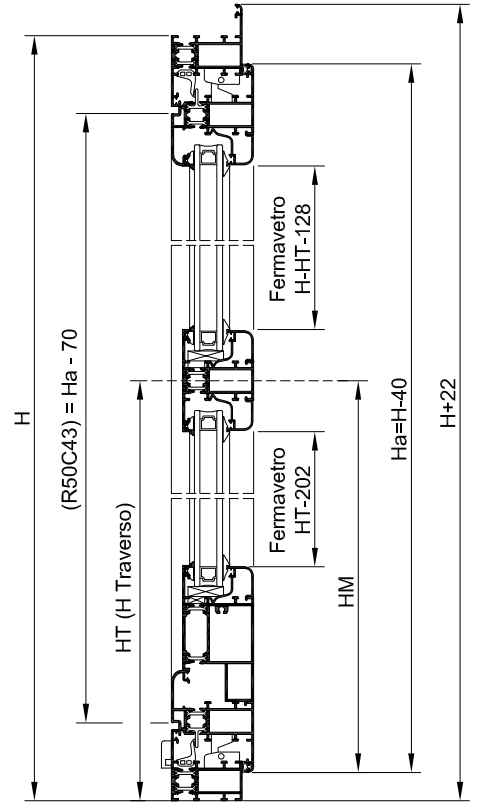
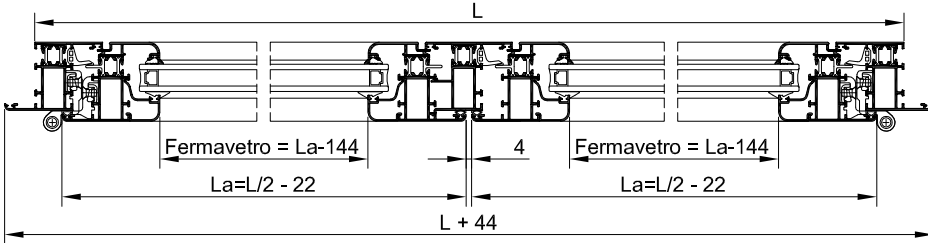

PROFILATI
SECTIONS

Profilato tipo Type Section	N° Pz.	Taglio Cut	N° Pz.	Taglio Cut
	1	H + 44	1	L + 44
	1	H + 44	1	L + 44
			1	L
	4	Ha= H - 40	4	La= L/2 - 22
			2	La - 91
			2	La - 91
	1	Ha - 70		
	4	H-HT-128	4	HT-202
			8	La-144
	1	(Inferiore/Lower) Hm - 131	1	(Superiore/Upper) Ha - Hm - 131

DIMENSIONE VETRO
GLASS SIZE

N. 2 PEZZI
HT - 168
La - 110

N. 2 PEZZI
H - HT - 94
La - 110

N.B.: Spessore vetro considerato 20 mm (4+12+4)
Gioco perimetrale tra profilato e vetro 5 mm
For glass with 20 mm thickness
Space between glass and profile 5 mm

ACCESSORI
ACCESSORIES

Articolo Item	Descrizione Description	N	Articolo Item	Descrizione Description	N	Articolo Item	Descrizione Description	N
A.3501.TA	Innesti per cremonese su prof. 900221(cp) Nylon pair of coupling internal opening for 900221	1	A.5662.AA	Squadretta a cianfrinare su prof. est. anta External corner joint to be crimped	8	403.806.05	Manovra catenaccio per puntali 404.145.55 Lever deadlatch for terminals 404.145.55	2
404.145.05	Puntali in zama su prof. 900221 (cp) Pair of zamak terminals on profile 900221	2	505.267.01	Giunto a "T" in alluminio estruso Extruded aluminium T joint	4	509.261.55	Cappetta scarico acqua (paratempsta) Water drain cover of nylon	2
2020(Mont.)	Squadretta Fuji allineamento aletta Fuji alignment corner joint on fin.	4	401.002.xx	Cerniera sfilabile con controp. in acc. inox Slip-of hinge with stainless steel counterplate	6	410.405.01	Basetta unificata per regolo mobile Unified plate for adjustable block	8
2013(Mont.)	Squadretta Fuji allineamento aletta Fuji alignment corner joint on fin.	10	A.4003.ZX	Cremonese reversibile per ap. int. Reversible cremone bolt for internal opening	1	510.415.01	Regolo mobile da 15 mm Adjustable block mm 15	8
2006(Mont.)	Squadretta Fuji allineamento aletta prof. compl. Fuji alignment corner joint for coplanar profiles	8	504.091.05	Riscontro registrabile per puntali 404.145.05 Adjustable striker for terminals 404.145.05	2	510.491.55	Tappo rotondo copriforo diametro 12 mm Circular coverhole plug dia. mm 12	8
A.5441.AA	Squadretta per giunzione d'angolo Corner joint	12	A.2129.TN	Coppia tappi per riporto centrale R50C43 Pair of plugs for central rabbet on profile R50C43	1	A.0228.EN	Angolo stampato per precamera R50TT-R72TT-R72TT1,3 Moulded corner for central weatherstrip R50TT-R72TT-R72TT1.3	4
			502.002.XX	Angolo stampato per fermavetro arrotondato Moulded corner for snap-on rounded glass beading	16	A.3204.ZA	Cavalotto di giunzione tela-traversi Tjoint for frames and transoms	12

GUARNIZIONI
WEATHERSTRIPS

Articolo Item	Descrizione Description	N	Articolo Item	Descrizione Description	N	Articolo Item	Descrizione Description
G.0126.EN	Guarnizione di battuta Weatherstrip of rabbet	6H 3L	G.0139.RN	Guarnizione esterna appoggio vetri 1,5 mm Weatherstrip on glass support mm 1.5	4H 4L		
G.0129.EN	Guarnizione interna tenuta vetro 5-6 mm Weatherstrip on glazing bead shim mm 5-6	4H 4L	G.0135.EN	Guarnizione di precamera R50TT - R72TT - R72TT1,3 Central weatherstrip R50TT - R72TT - R72TT1.3	3H 2L		

BILICO ORIZZONTALE
HORIZONTAL PIVOTING WINDOW

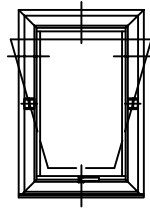

N.B.: - Le dimensioni di taglio e di lavorazione indicate nelle pagine seguenti sono state ottenute considerando le quote teoriche.
Pertanto è necessario verificare sempre le dimensioni dei profilati prima di effettuare i tagli.
Sapa declina ogni responsabilità per errori dovuti al mancato controllo da parte del costruttore.

N.B.: - The cutting and processing dimensions, indicated in the following pages, are obtained considering theoretical values.
It is, therefore, always necessary to check the dimensions of the profiles before executing the cutting.
Sapa declines any responsibility from errors caused from the missing dimensional check of the carpenter

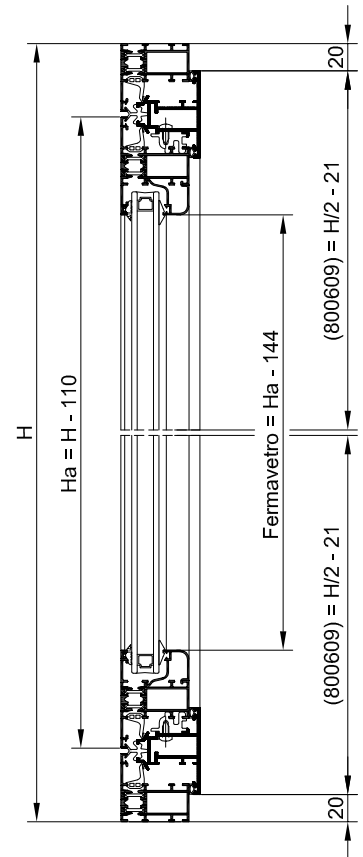
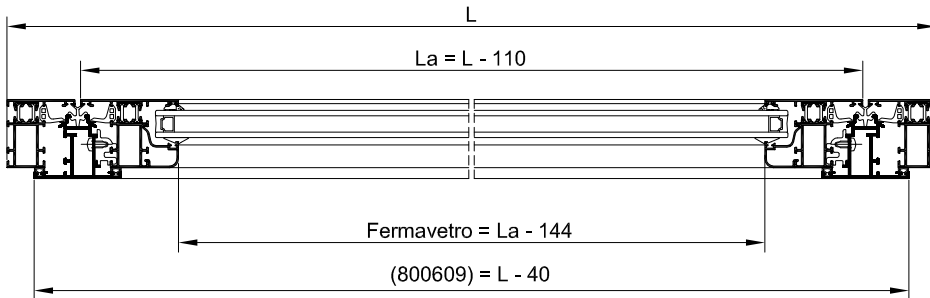

PROFILATI
SECTIONS

Profilato tipo Type Section	N° Pz.	Taglio Cut	N° Pz.	Taglio Cut
	2	H	2	L
	2	H/2 - 21	2	L - 40
	2	H/2 - 21		
	2	Ha = H - 110	2	La = L - 110
	2	Ha - 144	2	La - 144
	1	H	2	L

DIMENSIONI VETRO
GLASS SIZE

N. 1 PEZZO	N.B.: Spessore vetro considerato 20 mm (4+12+4) Gioco perimetrale tra profilato e vetro 5 mm For glass with 20 mm thickness Space between glass and profile 5 mm
Ha - 110	
La - 110	

* Per lavorazioni, taglio astine e montaggio accessori, consultare la tavola specifica del costruttore
For machining, cutting rods and mounting accessories, refer to the manufacturer's specification table

ACCESSORI
ACCESSORIES

Articolo Item	Descrizione Description	N	Articolo Item	Descrizione Description	N	Articolo Item	Descrizione Description	N
408.213.XX	Kit bilico orizzontale a chiusure multiple Kit multi-point lockings horizontal pivoting window	1	509.261.55	Cappetta scarico acqua (paratempsta) Water drain cover of nylon	2	502.002.XX	Angolo stampato per fermavetro arrotondato Moulded corner for snap-on rounded glass beading	4
508.025.01	Distanziale fissaggio profilo inversione bilico Spacer for fixing profile inversion pivoting window	*	410.405.01	Basetta unificata per regolo mobile Unified plate for adjustable block	5	404.121.05	Kit chiusura supplementare Kit additional lock	*
2020(Mont.)	Squadretta Fuji allineamento aletta Fuji alignment corner joint on fin.	10	510.415.01	Regolo mobile da 15 mm Adjustable block mm 15	5			
2013(Mont.)	Squadretta Fuji allineamento aletta Fuji alignment corner joint on fin.	6	510.491.55	Tappo rotondo copriforo diametro 12 mm Circular coverhole plug dia. mm 12	5			
A.5441.AA	Squadretta per giunzione d'angolo Corner joint	12	A.0228.EN	Angolo stampato per precamera R50TT - R72TT - R72TT1.3 Moulded corner for central weatherstrip R50TT-R72TT-R72TT1.3	8			

GUARNIZIONI
WEATHERSTRIPS

Articolo Item	Descrizione Description	N	Articolo Item	Descrizione Description	N	Articolo Item	Descrizione Description	N
G.0126.EN	Guarnizione di battuta Weatherstrip of rabbet	4H 4L	G.0139.RN	Guarnizione esterna appoggio vetri 1,5 mm Weatherstrip on glass support mm 1.5	2H 2L	G.0119.EN	Guarnizione di battuta per bilico pivoting weatherstrip of rabbet	2H 2L
G.0129.EN	Guarnizione interna tenuta vetro 5-6 mm Weatherstrip on glazing bead shim mm 5-6	2H 2L	G.0135.EN	Guarnizione di precamera R50TT - R72TT - R72TT1.3 Central weatherstrip R50TT - R72TT - R72TT1.3	4H 4L			

SQUADRETTA D'ANGOLO
CORNER JOINT

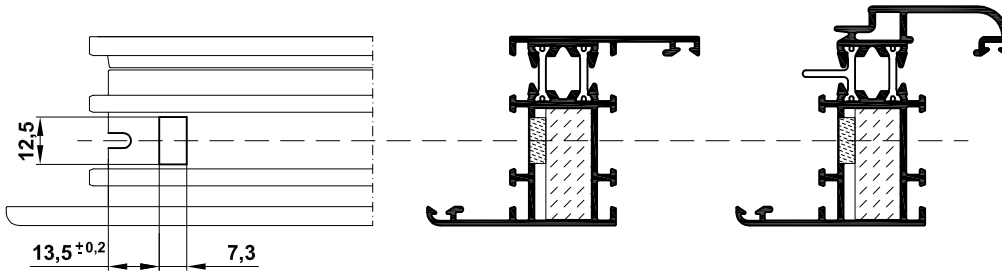

ART. : A.5441.AA



Attrezzatura: PUNZONATRICE
Tooling: PUNCHING MACHINE

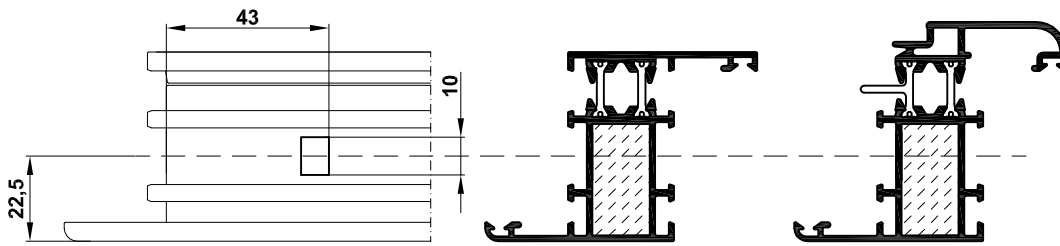

ART. : 5034



Attrezzatura: CIANFRINATRICE MANUALE
Tooling: MANUAL CRIMPING TOOL

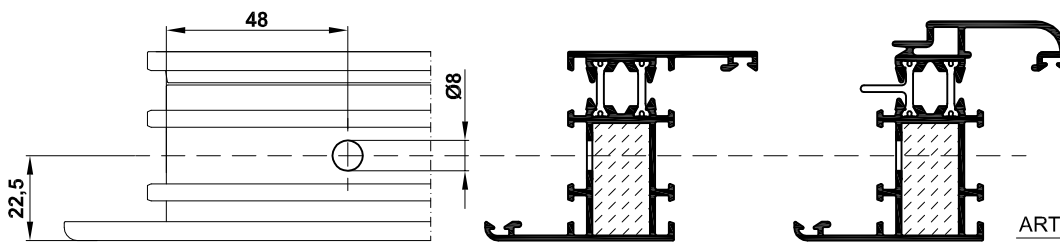

ART. : 5034



ART. : VILM 5x14_D8
(Monticelli)



Attrezzatura: TRAPANO
Tooling: DRILL

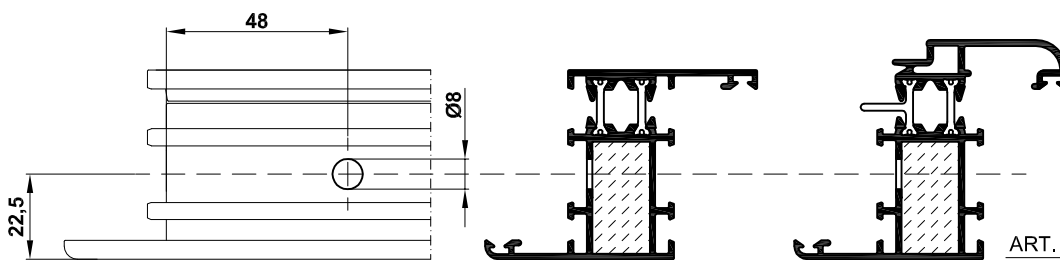

ART. : 5034



ART. : VILM 5x14_0088
(Monticelli)



Attrezzatura: TRAPANO
Tooling: DRILL

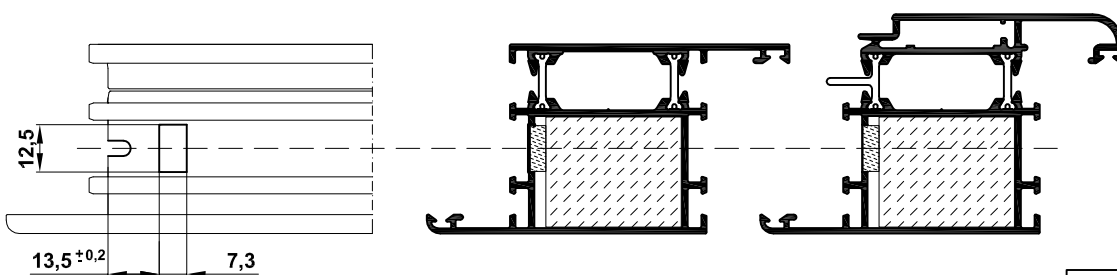

ART. : A.5429.AA



Attrezzatura: PUNZONATRICE
Tooling: PUNCHING MACHINE

SQUADRETTA D'ANGOLO
CORNER JOINT

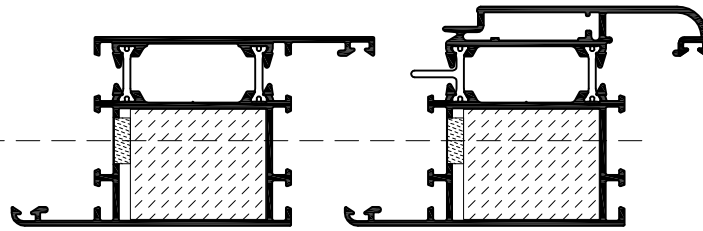
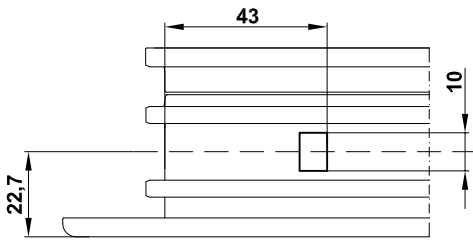

ART. : 5043



Attrezzatura: CIANFRINATRICE MANUALE
Tooling: MANUAL CRIMPING TOOL

LAVORAZIONE ESTERNA
EXTERNAL TOOLING

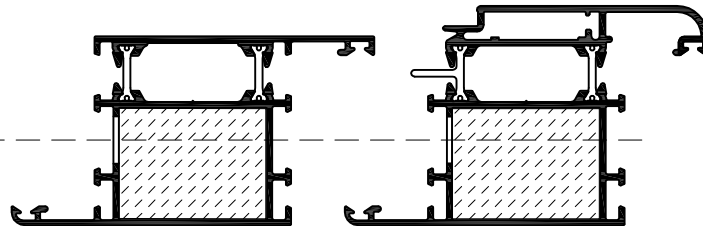
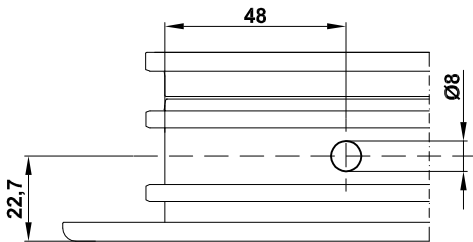

ART. : VILM 5x14_D8
(Monticelli)



ART. : 5043



Attrezzatura: TRAPANO
Tooling: DRILL

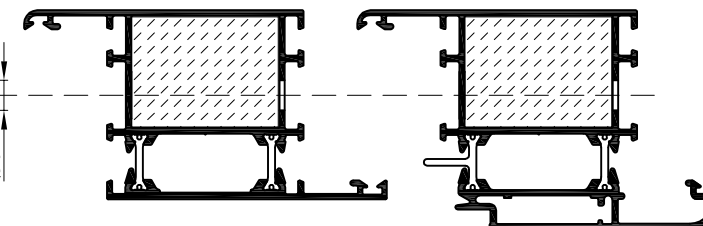
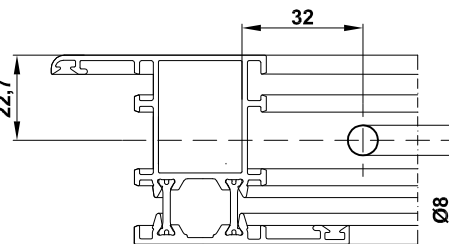

ART. : 5043



ART. : VILM 5x14_D8
(Monticelli)

LAVORAZIONE INTERNA
INTERNAL TOOLING

Attrezzatura: TRAPANO
Tooling: DRILL

LAVORAZIONE ESTERNA
EXTERNAL TOOLING

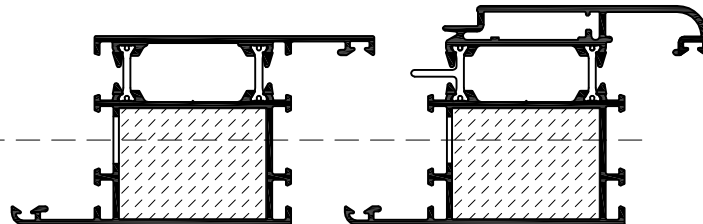
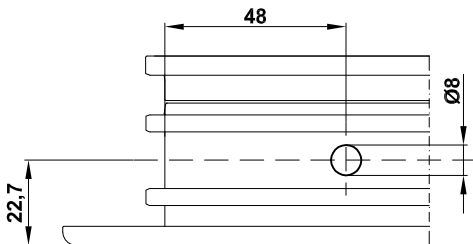

ART. : VILM 5x14_0088
(Monticelli)



ART. : 5043



Attrezzatura: TRAPANO
Tooling: DRILL

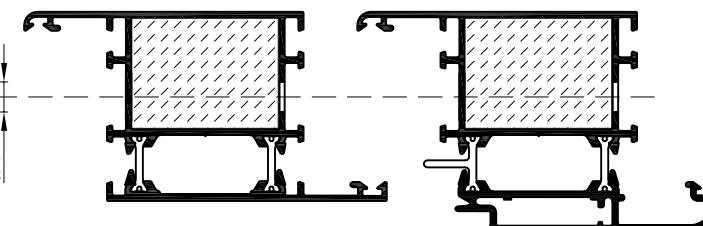
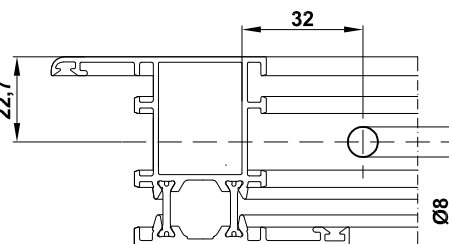

ART. : 5043



ART. : VILM 5x14_0088
(Monticelli)

LAVORAZIONE INTERNA
INTERNAL TOOLING

Attrezzatura: TRAPANO
Tooling: DRILL

SQUADRETTA D'ANGOLO
CORNER JOINT

ART. : A.5662.AA

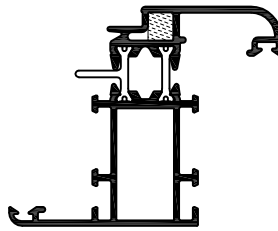
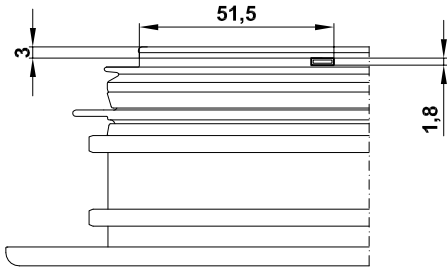

Per Profilati:
R50C42
R50C83
R50C105
R50C113



Attrezzatura: CIANFRINATRICE MANUALE
Tooling: MANUAL CRIMPING TOOL

ART. : 0133

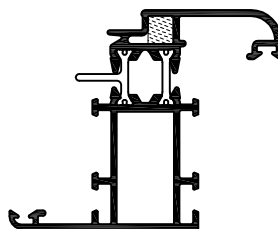
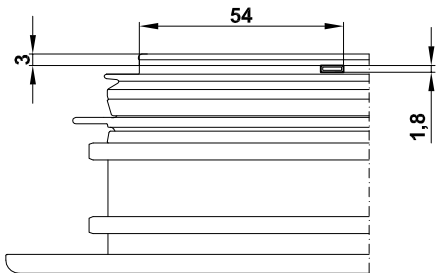

Per Profilati:
R50C42
R50C83
R50C105
R50C113



Attrezzatura: CIANFRINATRICE MANUALE
Tooling: MANUAL CRIMPING TOOL

ART. : 0133

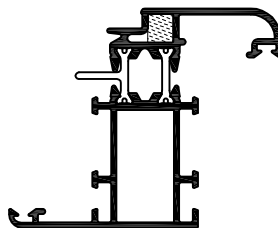
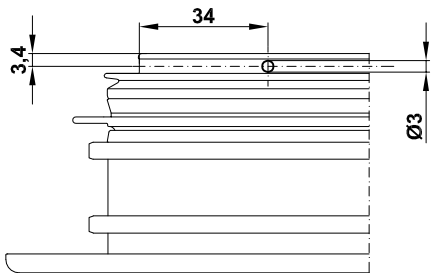

Per Profilati:
R50C42
R50C83
R50C105
R50C113



Spina 092 "Moticelli"

Attrezzatura: TRAPANO
Tooling: DRILL

ART. : A.5624.AA

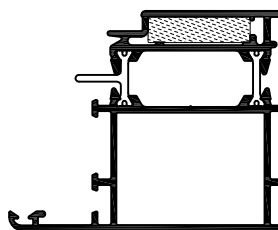
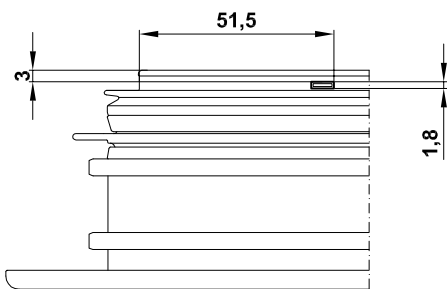

Per Profilati:
R50C53
R50C73
R50C98
R50C103
R50C106
R50C109



Attrezzatura: CIANFRINATRICE MANUALE
Tooling: MANUAL CRIMPING TOOL

ART. : A.2921.AA

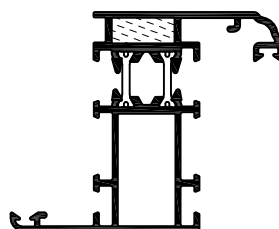
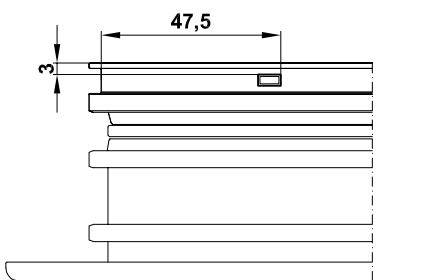

R50C82

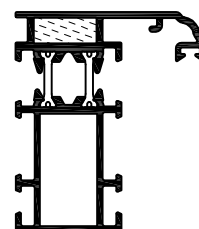

R50C81



Attrezzatura: CIANFRINATRICE MANUALE
Tooling: MANUAL CRIMPING TOOL

SQUADRETTA D'ANGOLO
CORNER JOINT

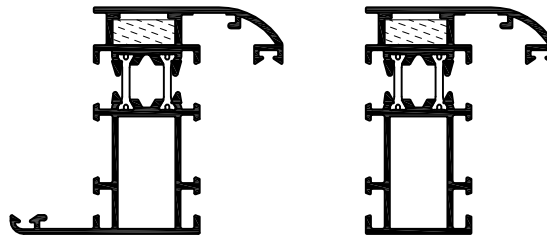
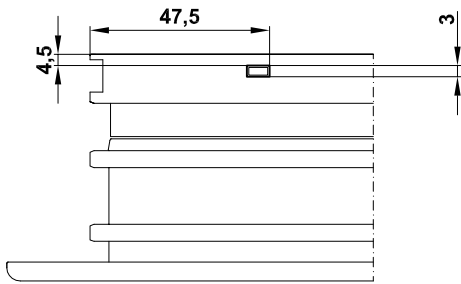

R50C145
R50C147

R50C144
R50C146

ART. : A.2921.AA



Attrezzatura: CIANFRINATRICE MANUALE
Tooling: MANUAL CRIMPING TOOL

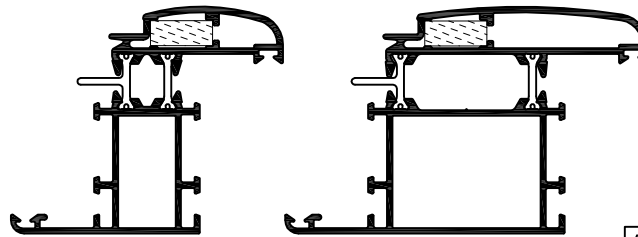
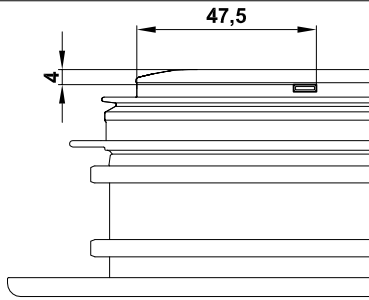

R50C75

R50C100

ART. : A.2921.AA



Attrezzatura: CIANFRINATRICE MANUALE
Tooling: MANUAL CRIMPING TOOL

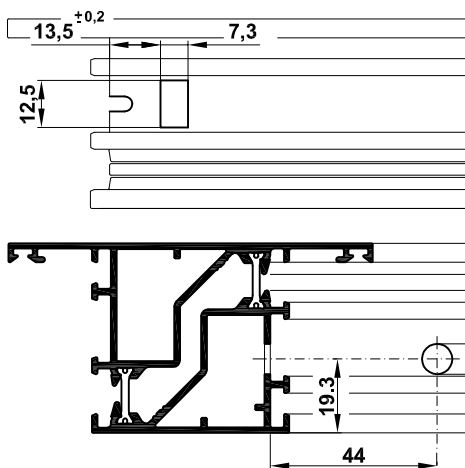

ESTERNA

INTERNA

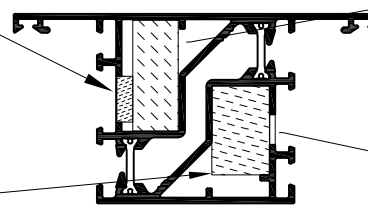

R50C104

ART. : A.5441.AA



Attrezzatura: PUNZONATRICE
Tooling: PUNCHING MACHINE

ART. : 5033



ART. : VILM 5x14_D8
(Monticelli)

Attrezzatura: TRAPANO
Tooling: DRILL

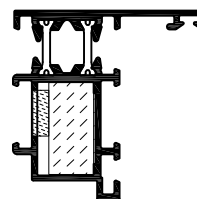
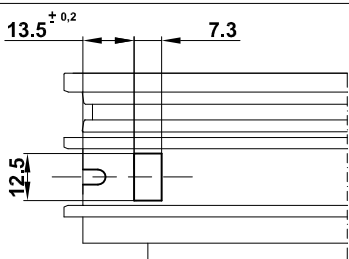

R50C115

A.2915.AA



Attrezzatura: PUNZONATRICE
Tooling: PUNCHING MACHINE

ASPORTAZIONE DENTINI PER INSERIMENTO ASTA
TOOTH REMOVAL FOR ROD NOTCH

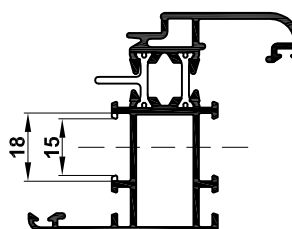
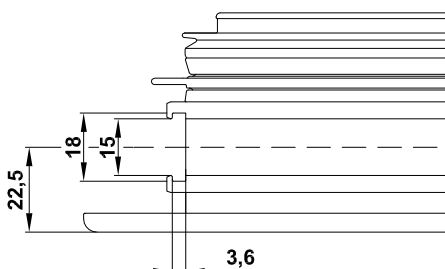

900221

Attrezzatura: PUNZONATRICE
Tooling: PUNCHING MACHINE

APPLICAZIONE SQUADRETTE DI ALLINEAMENTO
ALIGNMENT CORNER JOINTS APPLICATION

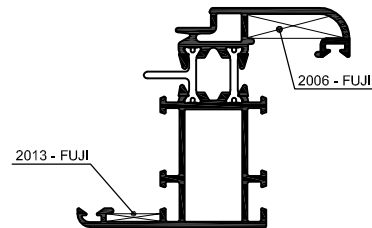
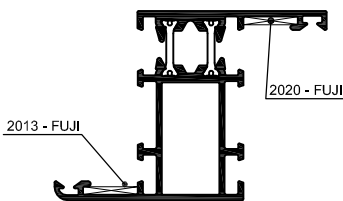
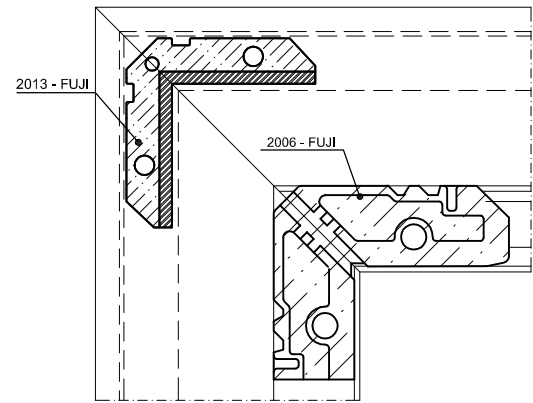
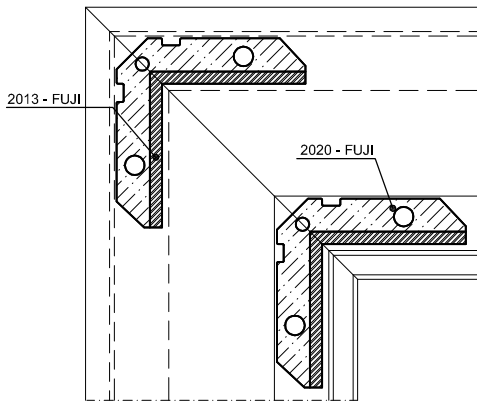

- Le squadrette di allineamento su alette, devono essere incollate con colle per alluminio di tipo epossidico bicomponente o di tipo poliuretano monocomponente

- The corner joints to be crimped, and alignment on fins, must be glued with bicomponent epoxy or monocomponent polyuretan glue for aluminium

INTESTATURA FASCE E ZOCCOLI
BUTTING HORIZONTAL PANELS - SKIRTING BOARDS

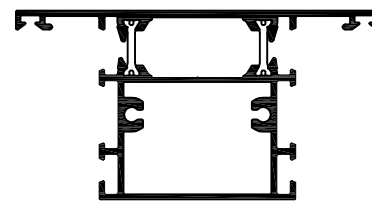
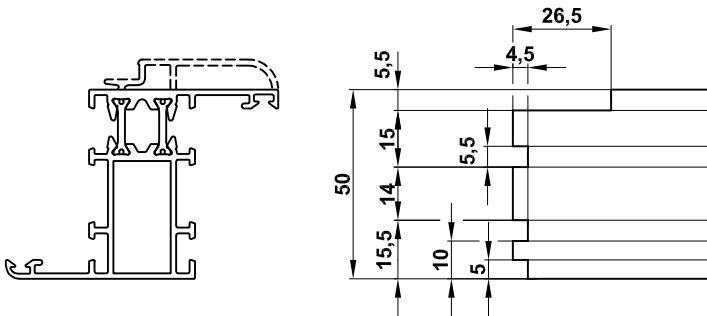

R50C46
R50C47
R50C54
R50C69
R50C121
R50C122

Attrezzatura: GRUPPO FRESE
Tooling: MILLING CUTTER GROUP

INTESTATURA FASCE E ZOCCOLI PER ANTE COMPLANARI
BUTTING HORIZONTAL PANELS - SKIRTING BOARDS FOR COPLANAR WINGS

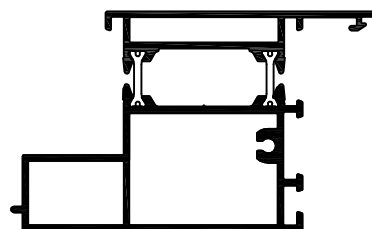
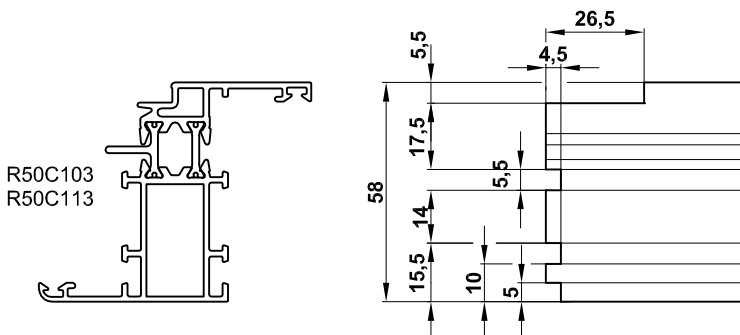

R50C103
R50C113

R50C112

Attrezzatura: GRUPPO FRESE
Tooling: MILLING CUTTER GROUP

INTESTATURA SOGLIA PROFILATO R72C96
BUTTING FRAME SECTIONS R72C96

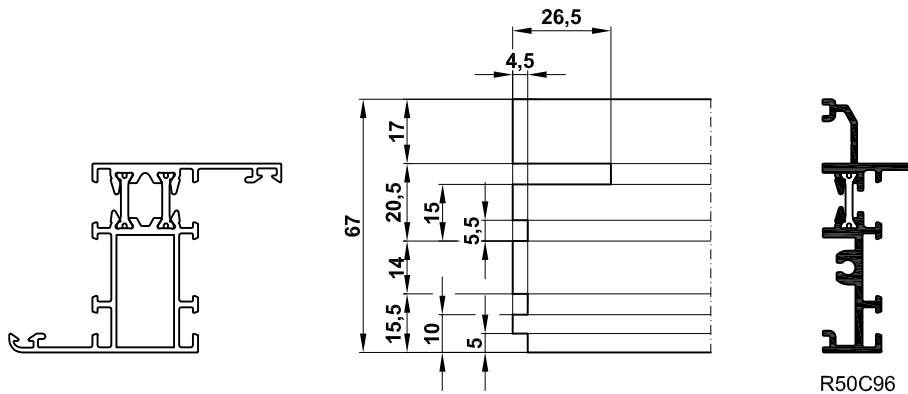

Attrezzatura: GRUPPO FRESE
Tooling: MILLING CUTTER GROUP

INTESTATURA SOGLIA PROFILATO 800728
BUTTING FRAME SECTIONS 800728

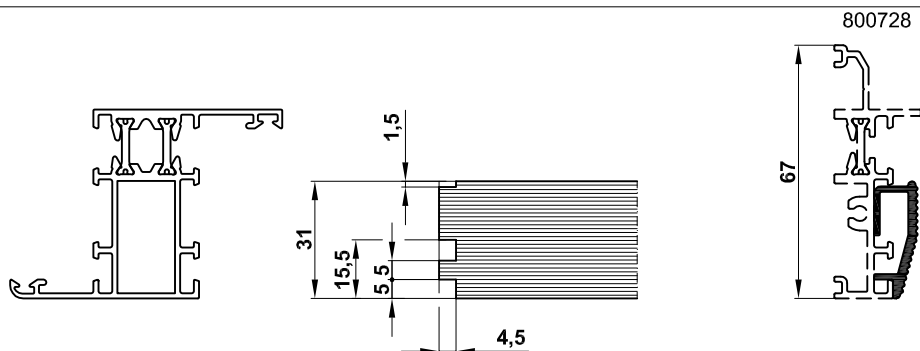

Attrezzatura: GRUPPO FRESE
Tooling: MILLING CUTTER GROUP

INTESTATURA SOGLIA PROFILATO 800729
BUTTING FRAME SECTIONS 800729

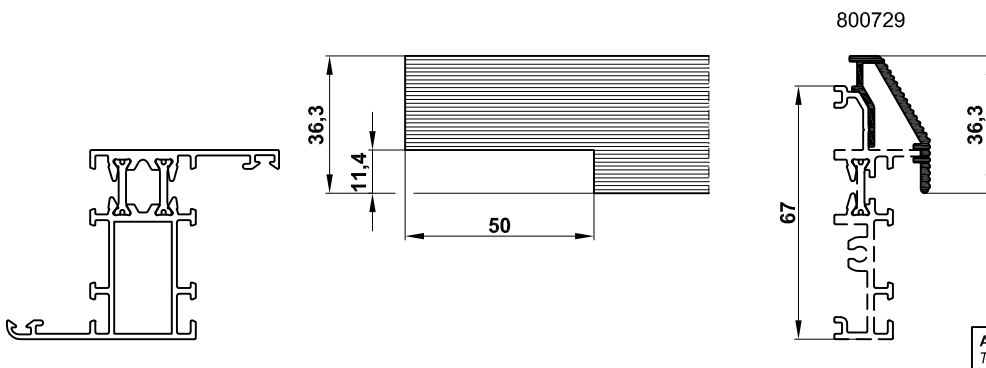

Attrezzatura: FRESA
Tooling: MILLING CUTTER

INTESTATURA VETRO AD INFILARE
BUTTING GLASS TO INSERT

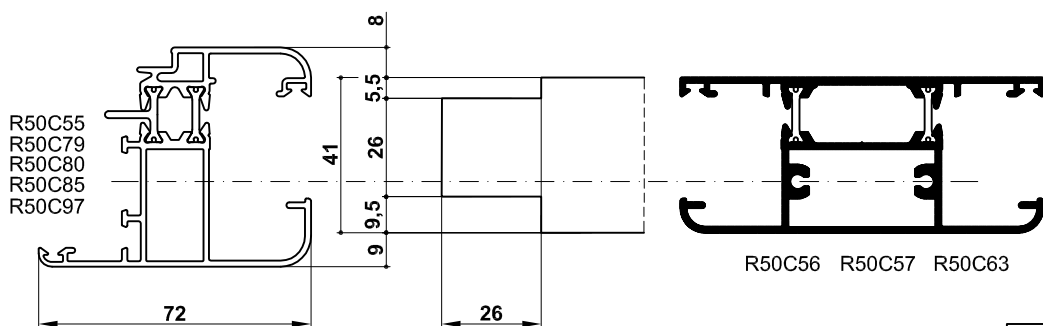

Attrezzatura: GRUPPO FRESE
Tooling: MILLING CUTTER GROUP

FORATURA PER REGOLO MOBILE
PUNCHING FOR ADJUSTABLE BLOCK

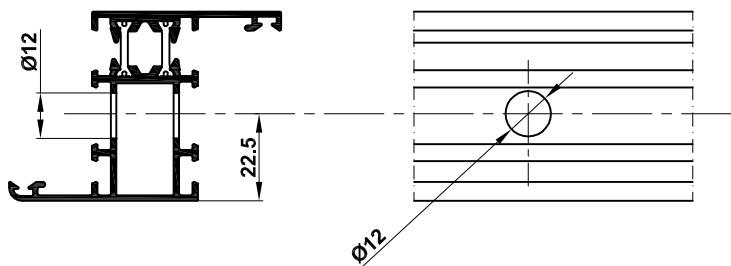

Art. 410.405.01

Art. 510.415.01
510.420.01
510.430.01
510.445.01
510.460.01

Attrezzatura: TRAPANO
Tooling: DRILL

CAVALLOTTI CON VITE
T JOINTS WITH SCREW

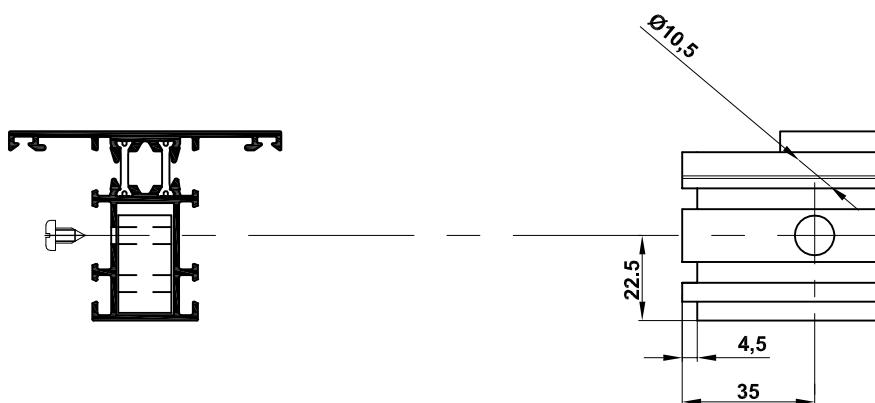

Art. 505.267.01

Attrezzatura: TRAPANO
Tooling: DRILL

MONTAGGIO CAVALLOTTO A.3204.ZA
ASSEMBLY TJOINTS A.3204.ZA

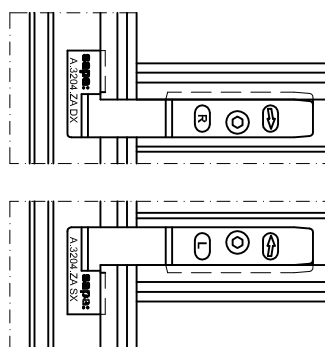
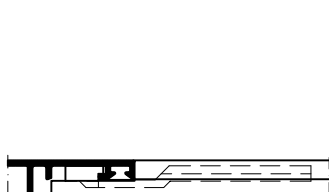

A.3204.ZA

FORATURA UNIONE FASCE - ZOCCOLI
PUNCHING FOR HORIZONTAL PANELS CONNECTION - SKIRTING BOARD

R50C46

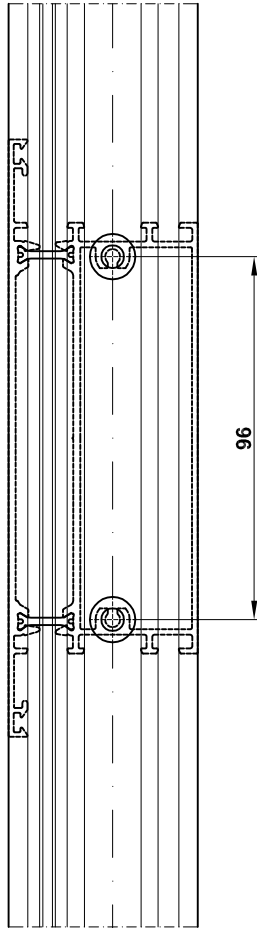

R50C69

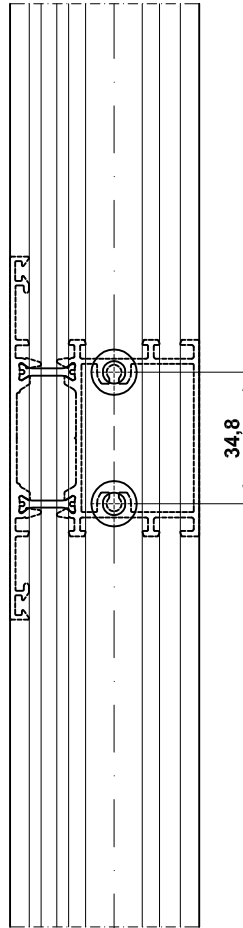

R50C47

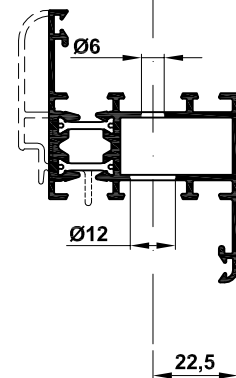
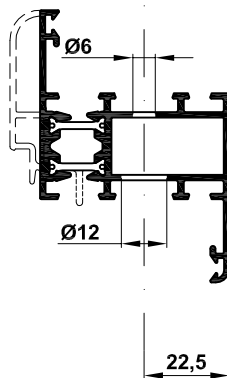
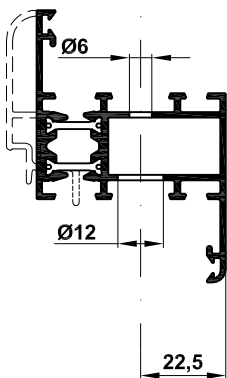
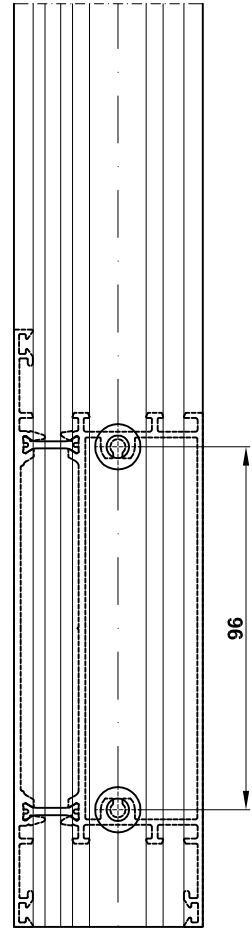

Attrezzatura: TRAPANO
Tooling: DRILL

FORATURA UNIONE FASCE - ZOCCOLI
PUNCHING FOR HORIZONTAL PANELS CONNECTION - SKIRTING BOARD

R50C54

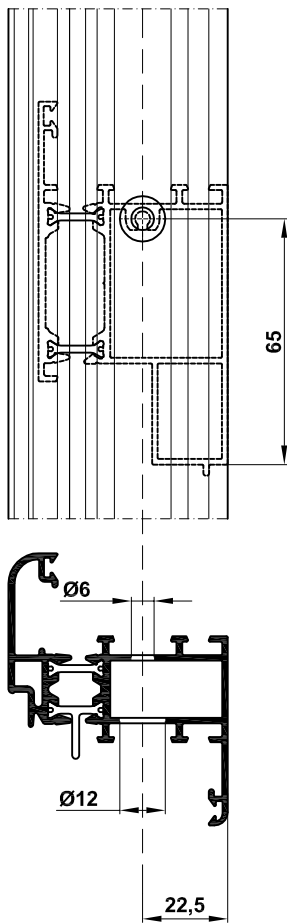

R50C112

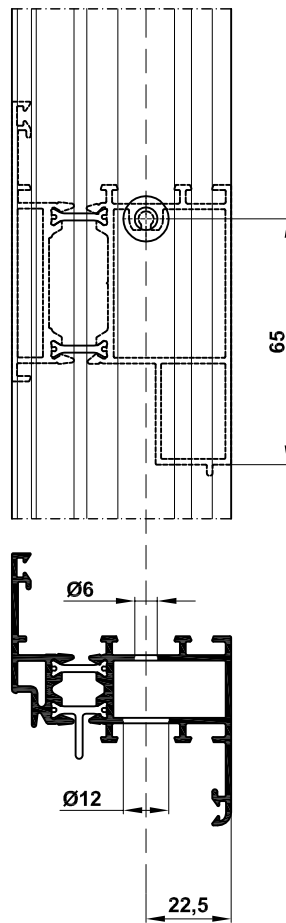

Attrezzatura: TRAPANO
Tooling: DRILL

FORATURA UNIONE FASCE - ZOCCOLI
PUNCHING FOR HORIZONTAL PANELS CONNECTION - SKIRTING BOARD

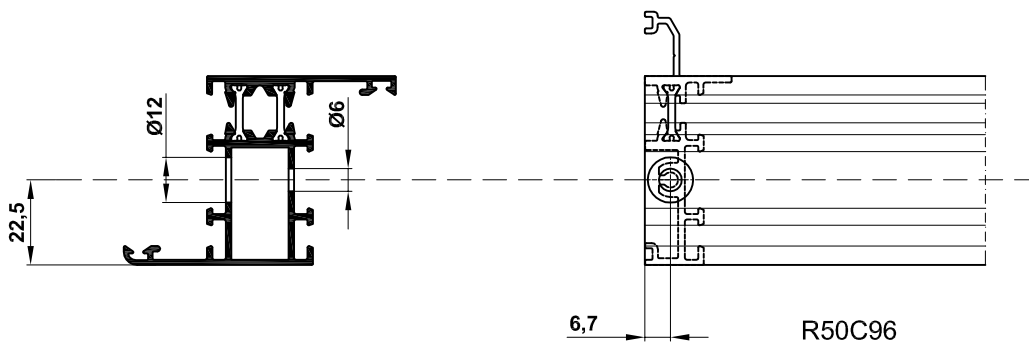

R50C96

Attrezzatura: TRAPANO
Tooling: DRILL

LAVORAZIONE DELUSSO ACQUA
TOOLING WATER DRAINAGE

Art. 509.260.55
509.261.55

Art. 509.264.55

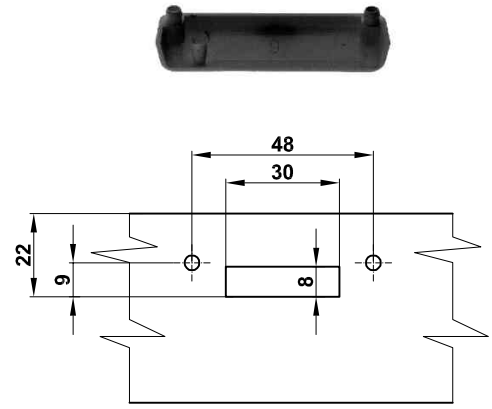
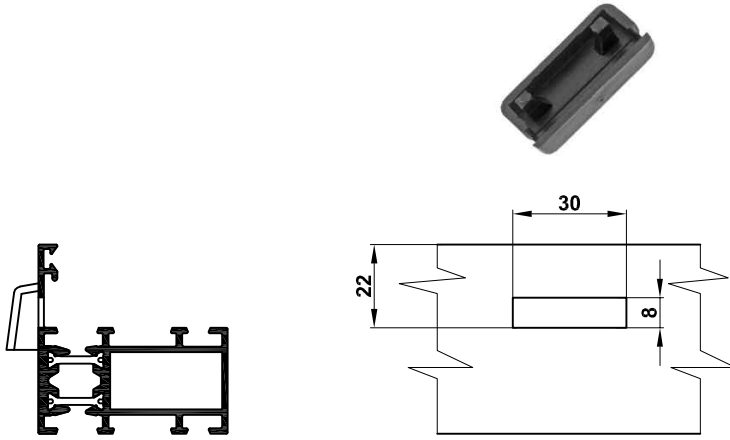

Attrezzatura: PUNZONATRICE
Tooling: PUNCHING MACHINE

Art. 509.260.55
509.261.55

Art. 509.264.55

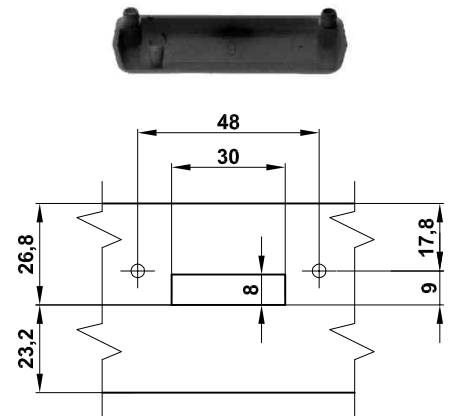
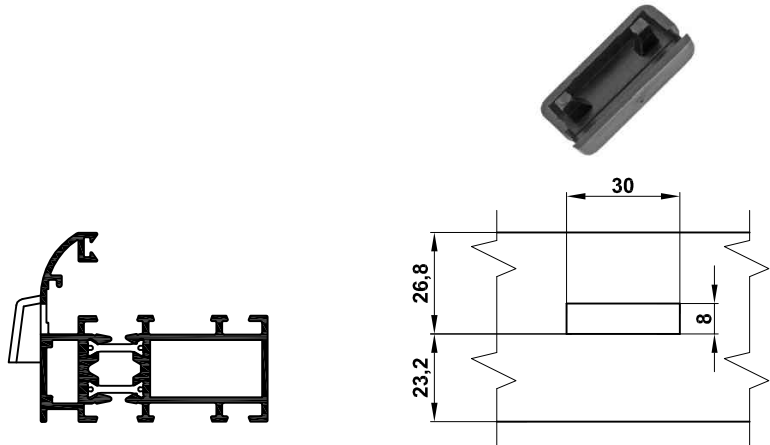

Attrezzatura: PUNZONATRICE
Tooling: PUNCHING MACHINE

Art. 509.260.55
509.261.55

Art. 509.264.55

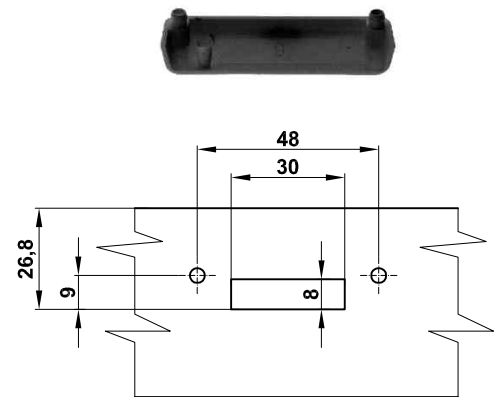
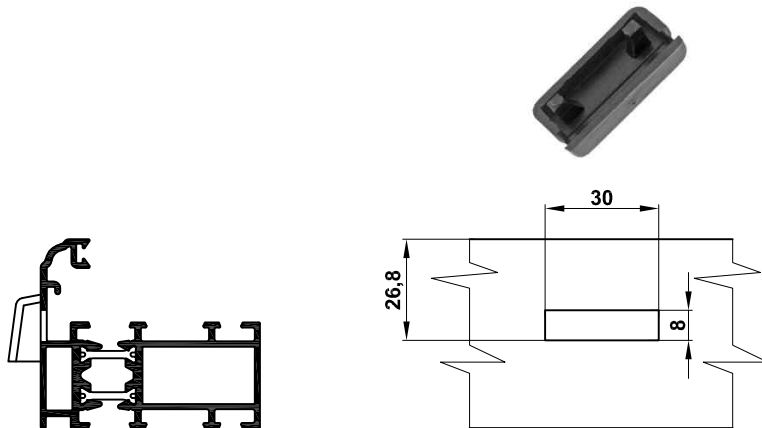

Attrezzatura: PUNZONATRICE
Tooling: PUNCHING MACHINE

LAVORAZIONI PER SCARICHI ACQUA E VENTILAZIONE VETRI
PROCESSING FOR WATER DRAINAGE AND GLASS VENTILATION

Posizione scarichi acqua
Water drainages position

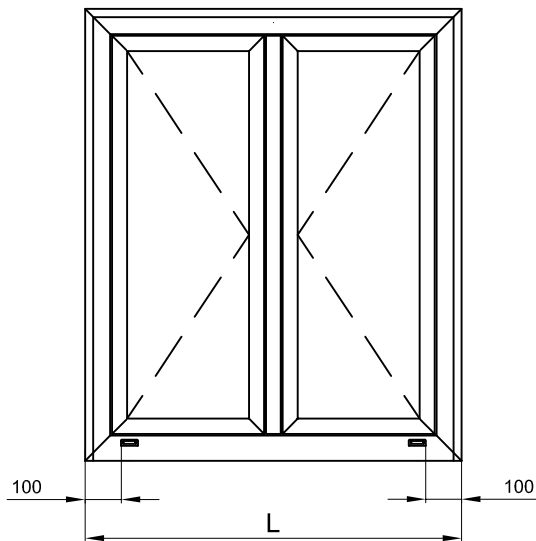

Posizione ventilazione vetri
Glass ventilation position

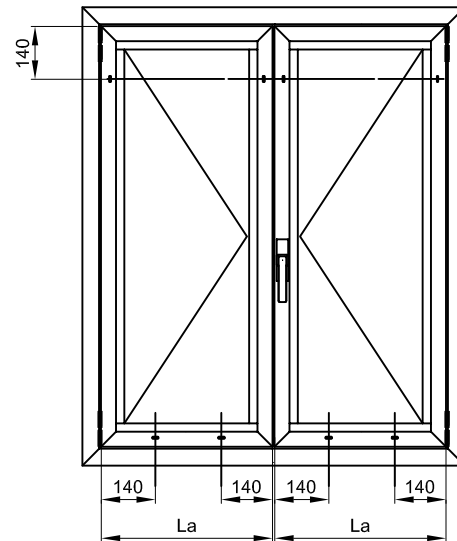

- Scarichi acqua:
N° 2 Per $L \leq 1400$ mm
N° 3 Per $L > 1400$ mm ≤ 2100 mm
N° 4 Per $L > 2100$ mm ≤ 2800 mm
- Water drains:
N° 2 For $L \leq 1400$ mm
N° 3 For $L > 1400$ mm ≤ 2100 mm
N° 4 For $L > 2100$ mm ≤ 2800 mm

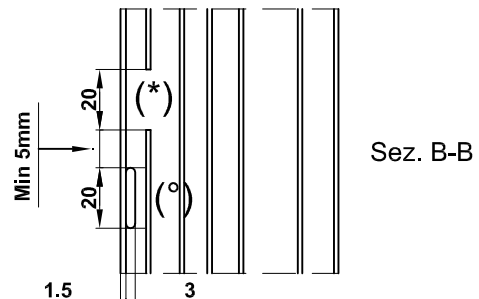
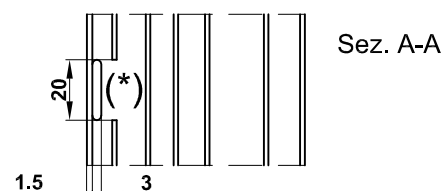
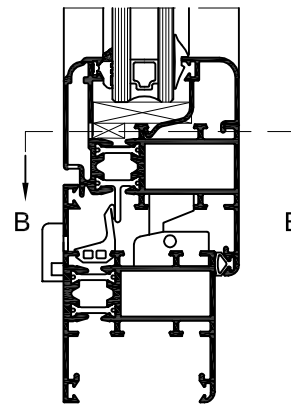
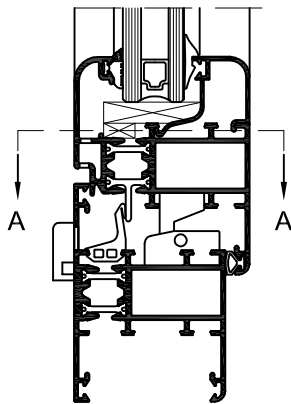

(*) Asportazione dentino solo su profilato anta lato inferiore
in corrispondenza scarico acqua

Teeth removal only on lower wing section
corresponding to the water drainage hole

(*) Asola da 20x 5mm spostata rispetto all'altra lavorazione
(°) Asola da 20x 3mm in corrispondenza dello scarico acqua

(*) Slot 20x5mm not corresponding to the other tooling
(°) Slot 20x3mm corresponding to the water drainage hole

Attrezzatura: TRAPANO - PANTOGRAFO
Tooling: DRILL - PANTOGRAPH

PUNTALI ED INNESTI CREMONESI

Coppia puntali in zama
Pair of zamak terminals
Art. 404.145.05

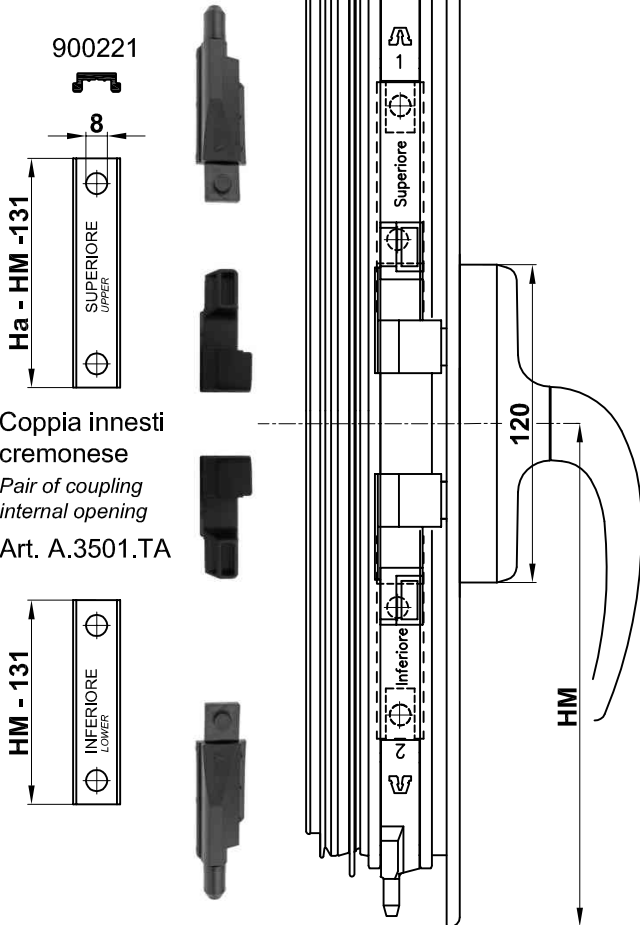

Coppia puntali in nylon
Pair of nylon terminals
Art. 404.141.55

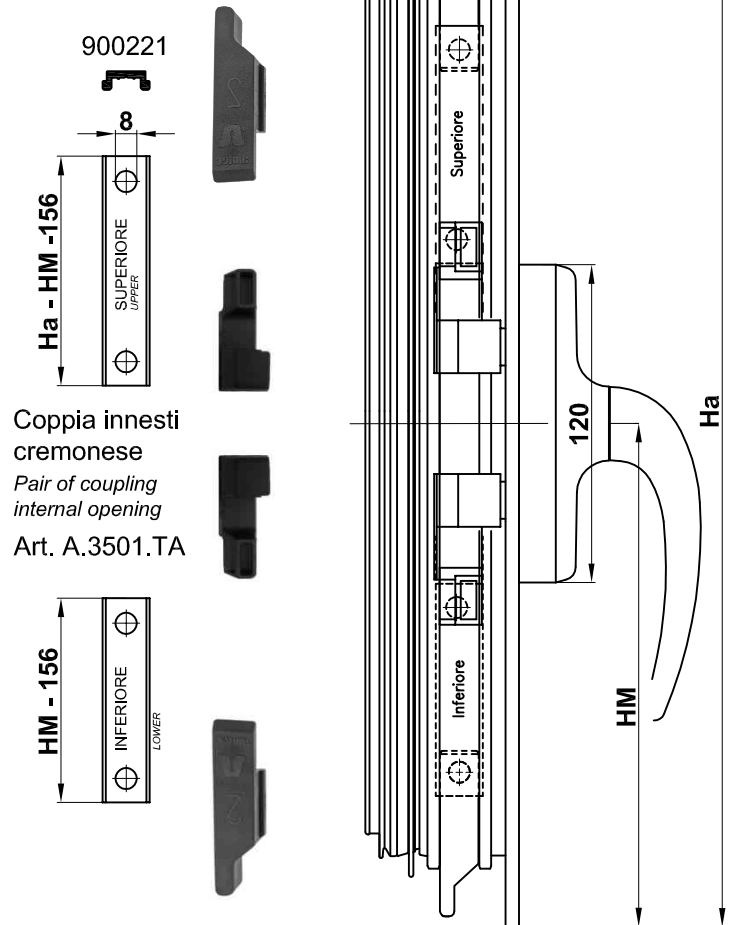

LAVORAZIONE PER CREMONESI
TOOLING FOR CREMONES BOLT

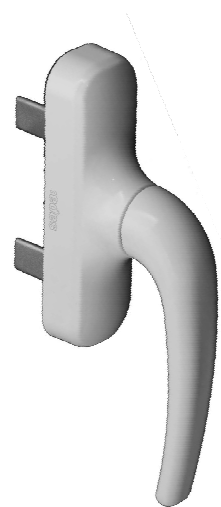
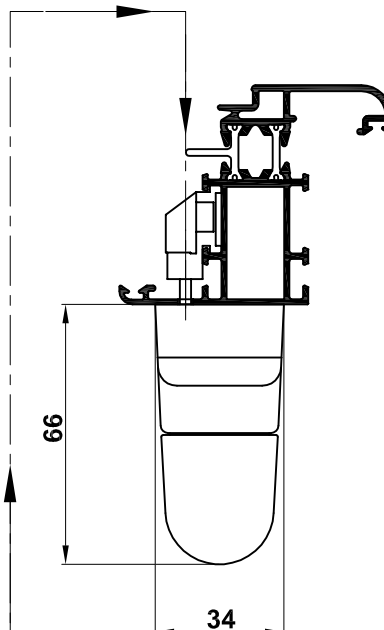
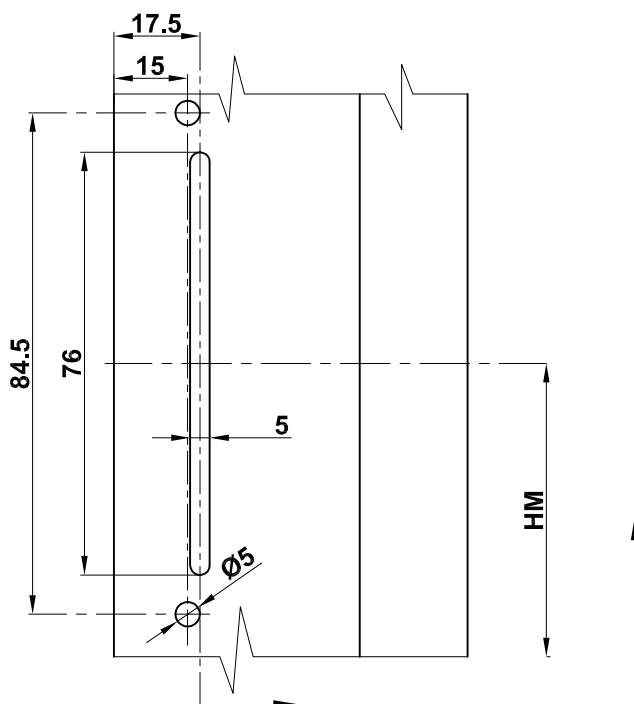

Cremonese reversibile Sapa
Reversible cremonese
Art. A.4003.ZX

APERTURA ESTERNA R50C51
EXTERNAL OPENING R50C51



Coppia puntali in zama
Pair of zamak terminals
Art. 404.145.05

Perno di collegamento
Connecting pin
Art. A.4016.IA

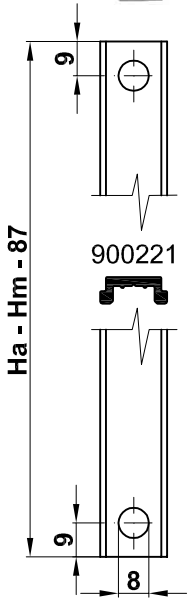
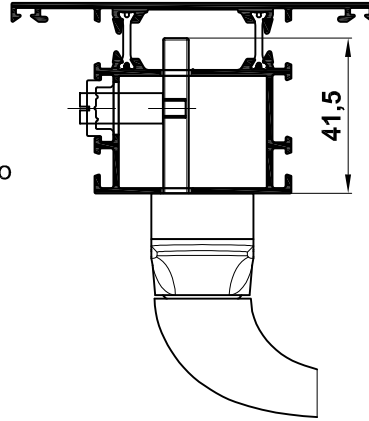

SUPERIORE
UPPER

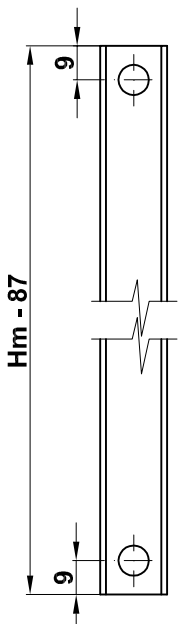

INFERIORE
LOWER

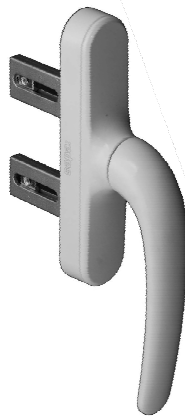
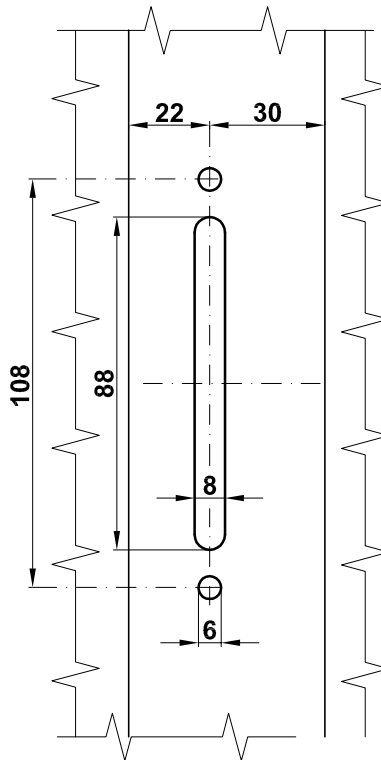

Cremonese Apertura Esterna
Reversible cremone bolt
Art. A.4006.ZX

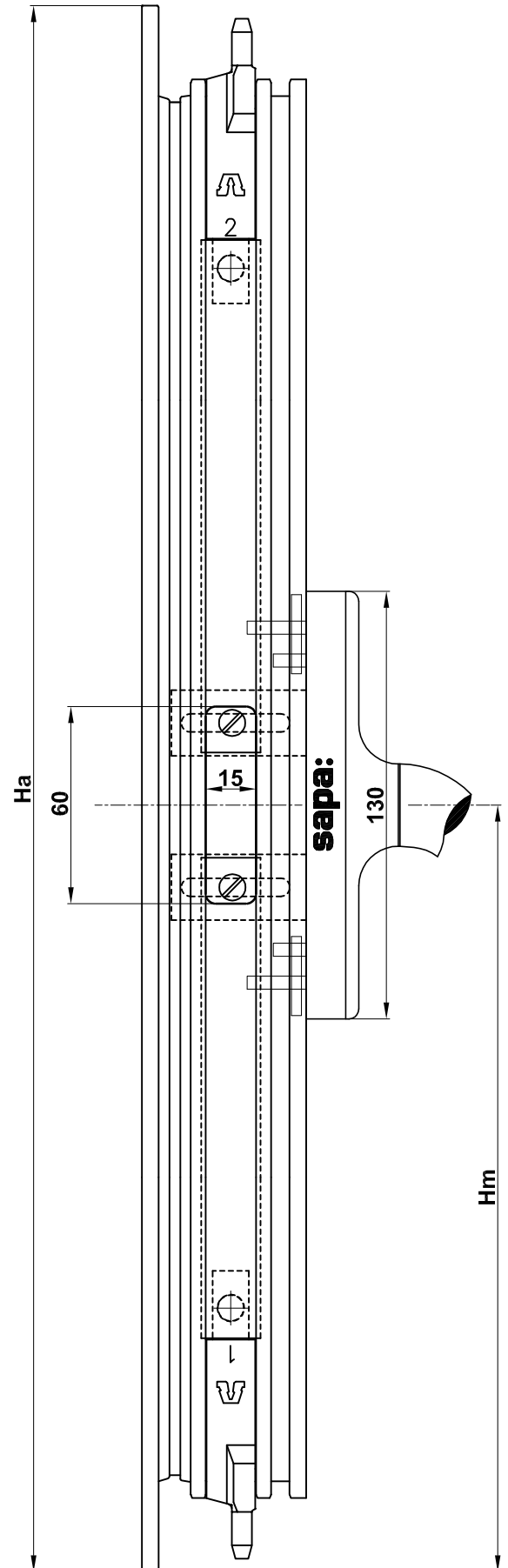

APERTURA ESTERNA R50C104
EXTERNAL OPENING R50C104



Coppia puntali in zama
Pair of zamak terminals
Art. 404.145.05

Perno di collegamento
Connecting pin
Art. A.4016.IA

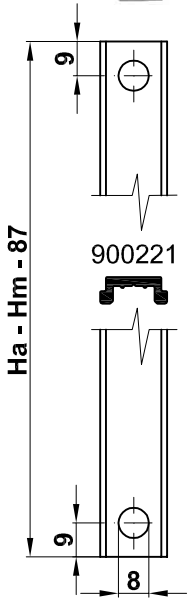
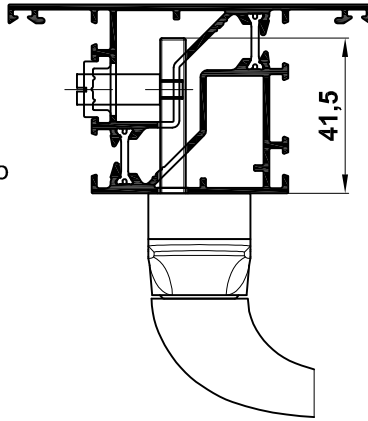

900221

SUPERIORE
UPPER

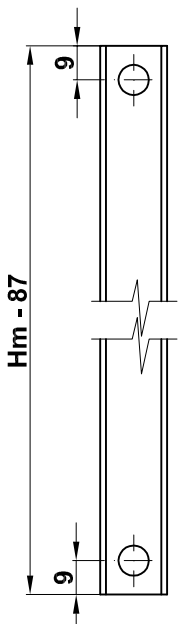

INFERIORE
LOWER

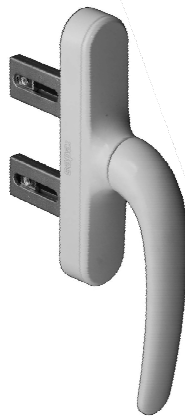
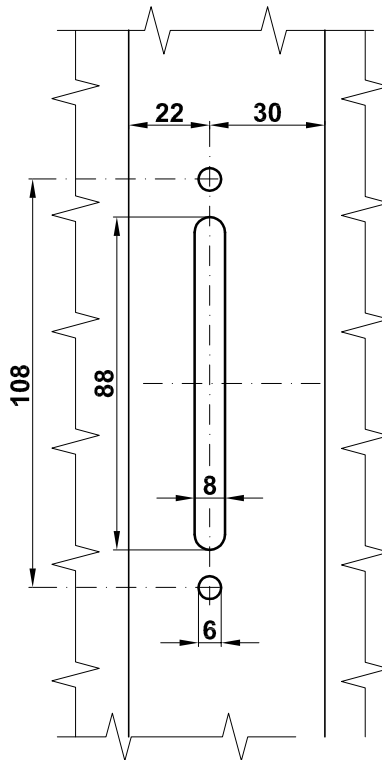

Cremonese Apertura Esterna
Reversible cremone bolt
Art. A.4006.ZX

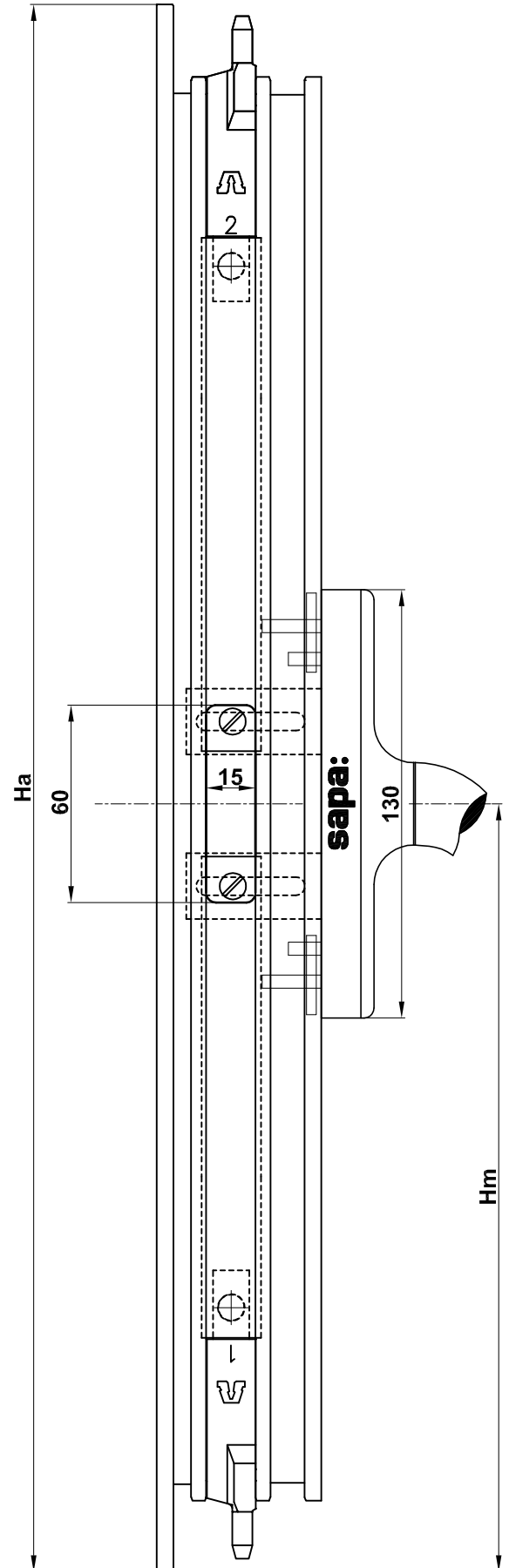

GRUPPO ARTICOLAZIONE RINFORZATO PER SPORGERE PORTATA 90Kg
RELEASABLE ARMS FOR HOPPER WINDOW

Il sistema a sporgere R50TT, è basato sul bilanciamento dell'anta che deve rimanere in equilibrio indipendentemente dalla sua posizione in apertura. Per ottenere le prestazioni ottimali e garantite, il peso dell'anta deve scaricarsi sempre sui bracci e mai sullo scivolo.

Per verificare l'equilibratura dell'anta si può procedere nella seguente maniera: se i bracci sono stati montati troppo in basso l'anta tenderà ad aprirsi autonomamente, viceversa se sono stati montati troppo in alto l'anta tenderà a chiudersi

R50TT, awning systems with load-bearing arms, are based on the balancing of the sash which must remain balanced regardless of its opening position. If the arms have been mounted too low the sash will tend to open on its own while viceversa, if they have been mounted too high up, the sash tends to close.

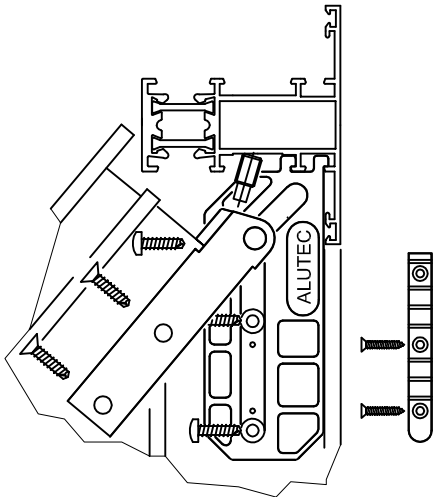

Posizione P Position P	
H anta H wing	P
500	NON FATTIBILE
600	183
700	223
800	265
900	285
1000	300
1100	318
1200	332
1300	342
1400	352
1500	362
1600	370
1700	377
1800	384
1900	392
2000	400

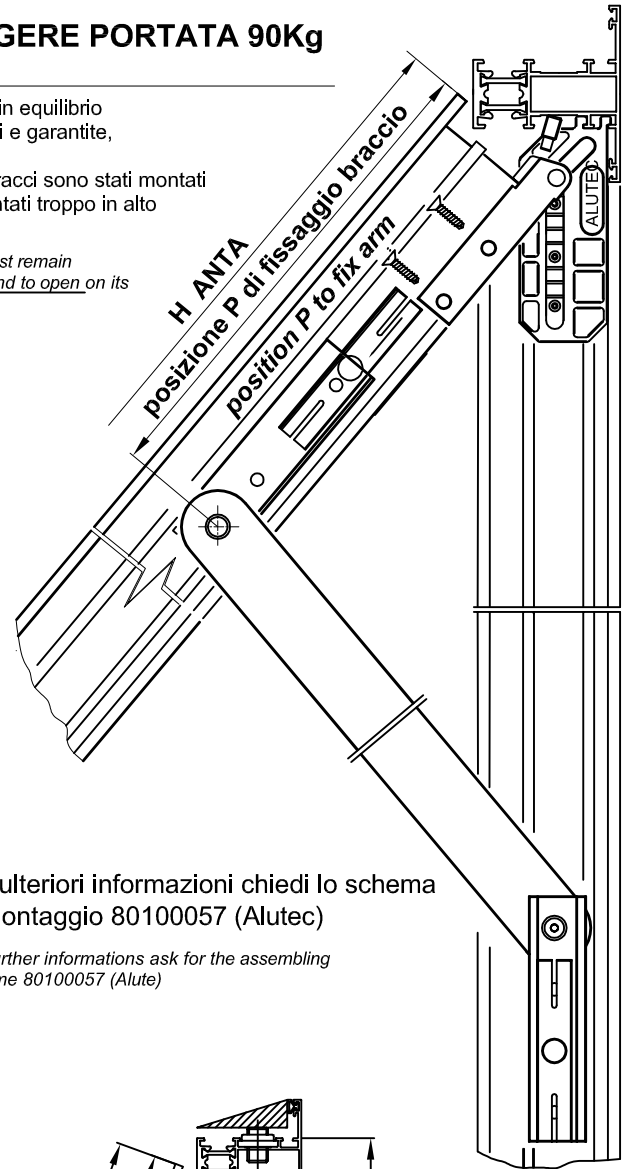

Per ulteriori informazioni chiedi lo schema di montaggio 80100057 (Alutec)

For further informations ask for the assembling scheme 80100057 (Alute)

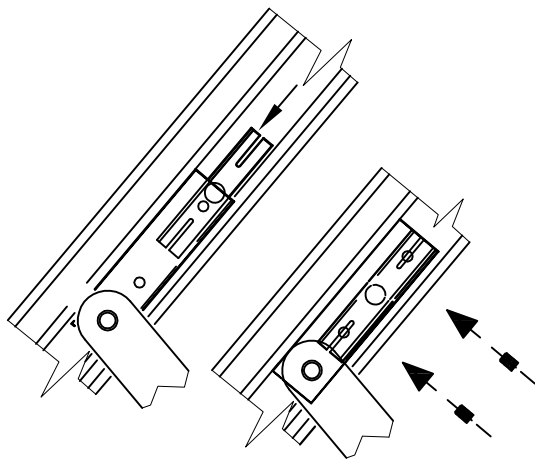

Art. 406.499.05

A = Da stabilire in funzione dell'autobilanciamento

A = To be established according to self-balancing

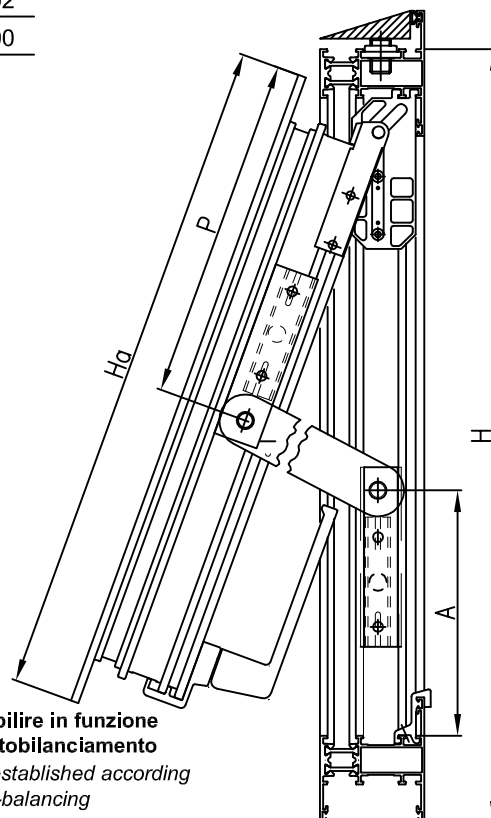

BRACCI SGANCIABILI AMMORTIZZATI PER VASISTAS
RELEASABLE AND AMORTIZED ARMS FOR VASISTAS

CAMPO DI APPLICAZIONE APPLICATION RANGE										
		Art. A.3907.IA H da 1000 a 2000mm			Art. A.3906.IA H da 350 a 1600mm			Art. A.3905.IA H da 250 a 500mm		
H	A	B	C	A	B	C	A	B	C	
250							0	40	145	
300							0	40	132	
							50	90	171	
350				0	150	250	0	40	124	
							50	90	152	
							100	140	198	
400				0	150	220	0	40	119	
				50	200	284	50	90	140	
							100	140	172	
450				0	150	202	0	40	115	
				50	200	246	50	90	132	
				100	250	318	100	140	157	
							150	190	193	
500				0	150	190	0	40	112	
				50	200	223	50	90	127	
				100	250	272	100	140	146	
				150	300	353	150	190	173	
550				0	150	181				
				50	200	208				
				100	250	244				
				150	300	299				
600				0	150	174				
				50	200	197				
				100	250	226				
				150	300	266				
				200	350	325				
700				0	150	165				
				100	250	202				
				200	350	282				
800				0	150	159				
				100	250	188				
				200	350	230				
900				0	150	155				
				100	250	178				
				200	350	210				
				300	450	257				
1000	0	340	238	0	150	151				
	100	440	278	100	250	170				
	200	540	334	200	350	196				
	300	640	421	300	450	232				
1100	0	340	229	0	150	148				
	100	440	261	100	250	165				
	200	540	305	200	350	187				
	300	640	366	300	450	215				
1200	0	340	223	0	150	146				
	100	440	250	100	250	161				
	200	540	284	200	350	180				
	300	640	332	300	450	203				
	400	740	400	400	550	235				
1300	0	340	217	0	150	145				
	100	440	240	100	250	158				
	200	540	270	200	350	174				
	300	640	308	300	450	194				
	400	740	359	400	550	220				
1400	0	340	213	0	150	144				
	100	440	233	100	250	156				
	200	540	258	200	350	170				
	300	640	290	300	450	187				
	400	740	331	400	550	209				
1500	0	340	209	0	150	142				
	100	440	227	100	250	153				
	200	540	249	200	350	166				
	300	640	276	300	450	181				
	400	740	310	400	550	200				
	500	840	354	500	650	223				
1600	0	340	200	0	150	141				
	100	440	223	100	250	151				
	200	540	242	200	350	163				
	300	640	265	300	450	177				
	400	740	294	400	550	193				
	500	840	330	500	650	213				
1700	0	340	204							
	100	440	219							
	200	540	236							
	300	640	257							
	400	740	282							
	500	840	312							
1800	0	340	201							
	100	440	215							
	200	540	231							
	300	640	250							
	400	740	271							
	500	840	298							
	600	940	330							
1900	0	340	199							
	100	440	212							
	200	540	227							
	300	640	243							
	400	740	263							
	500	840	286							
	600	940	315							
2000	0	340	198							
	100	440	210							
	200	540	223							
	300	640	243							
	400	740	263							
	500	840	286							
	600	940	315							

Art. A.3905.IA	Braccio corto short arm
Art. A.3906.IA	Braccio medio medium arm
Art. A.3907.IA	Braccio lungo long arm

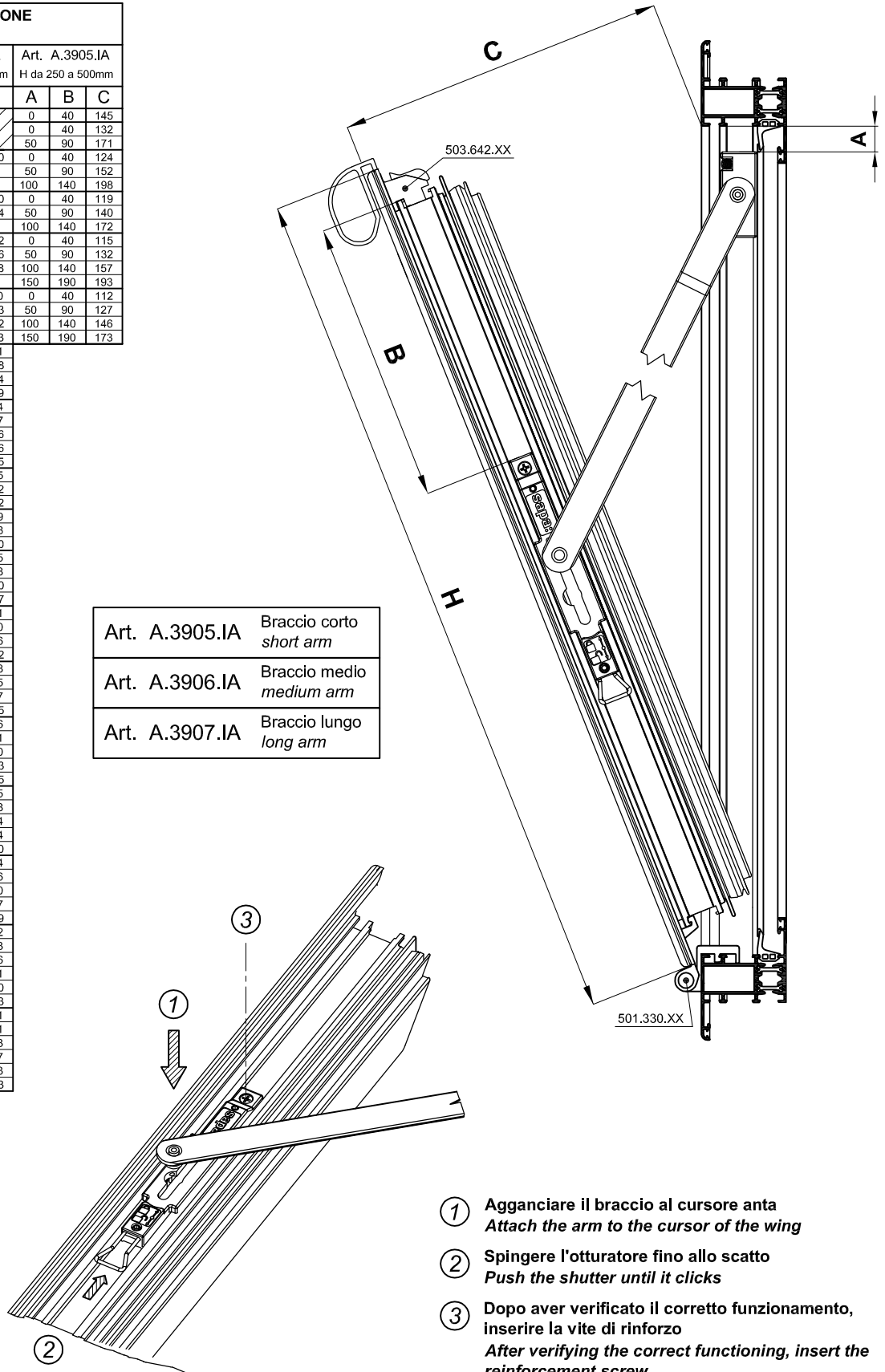

- ① Agganciare il braccio al cursore anta
Attach the arm to the cursor of the wing
- ② Spingere l'otturatore fino allo scatto
Push the shutter until it clicks
- ③ Dopo aver verificato il corretto funzionamento,
inserire la vite di rinforzo
After verifying the correct functioning, insert the
reinforcement screw

Per sganciare, eseguire l'operazione inversa.
To release, perform the inverse operation.

SERRATURE DA INFILARE MULTIPUNTO AD INGRANAGGI - COMPLANARE 1 e 2 ANTE
LOCK

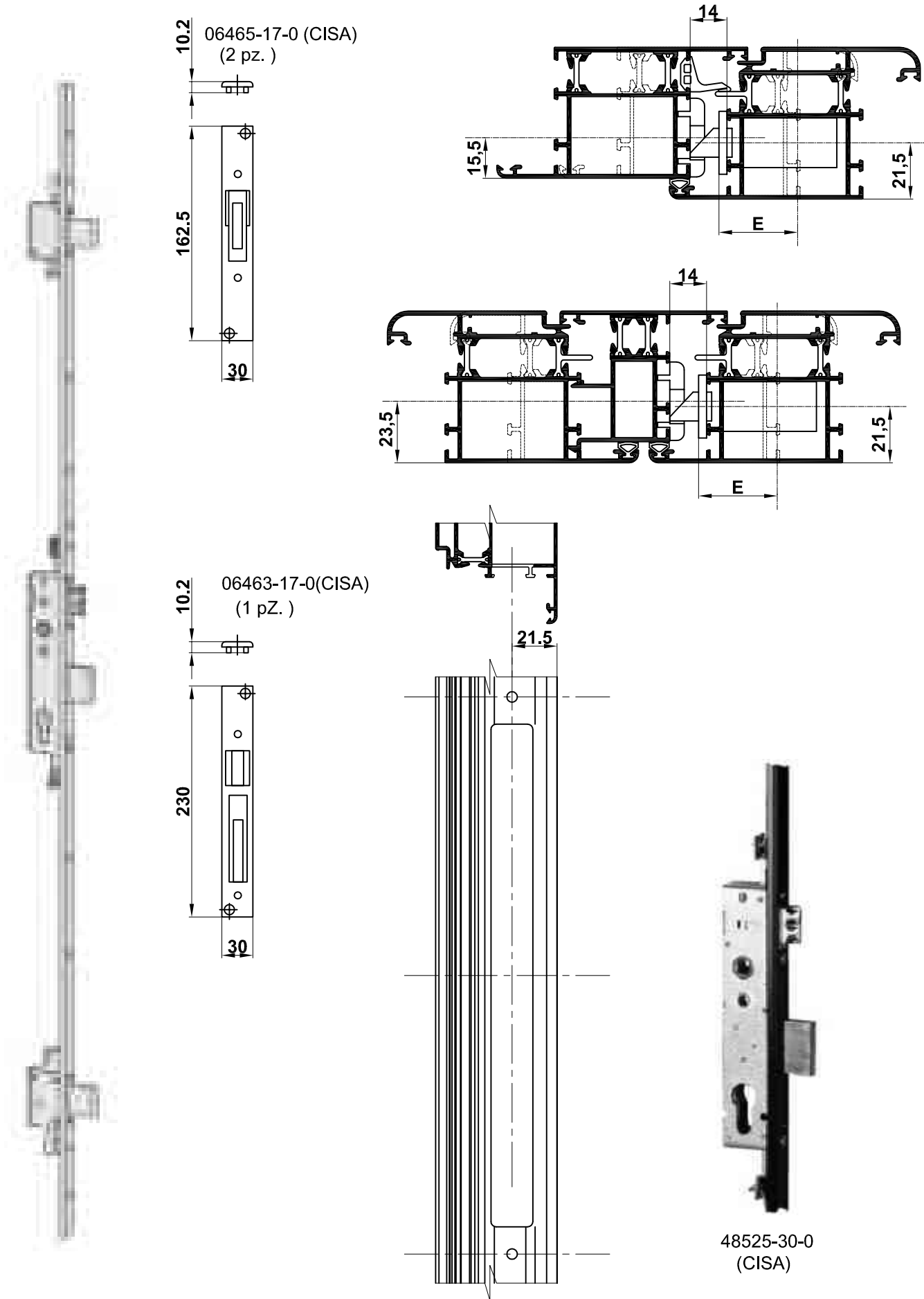

POSIZIONAMENTO FISSAGGIO ART. 508.025.01
MOUNTING POSITION ART. 508.025.01

ART. 508.025.01

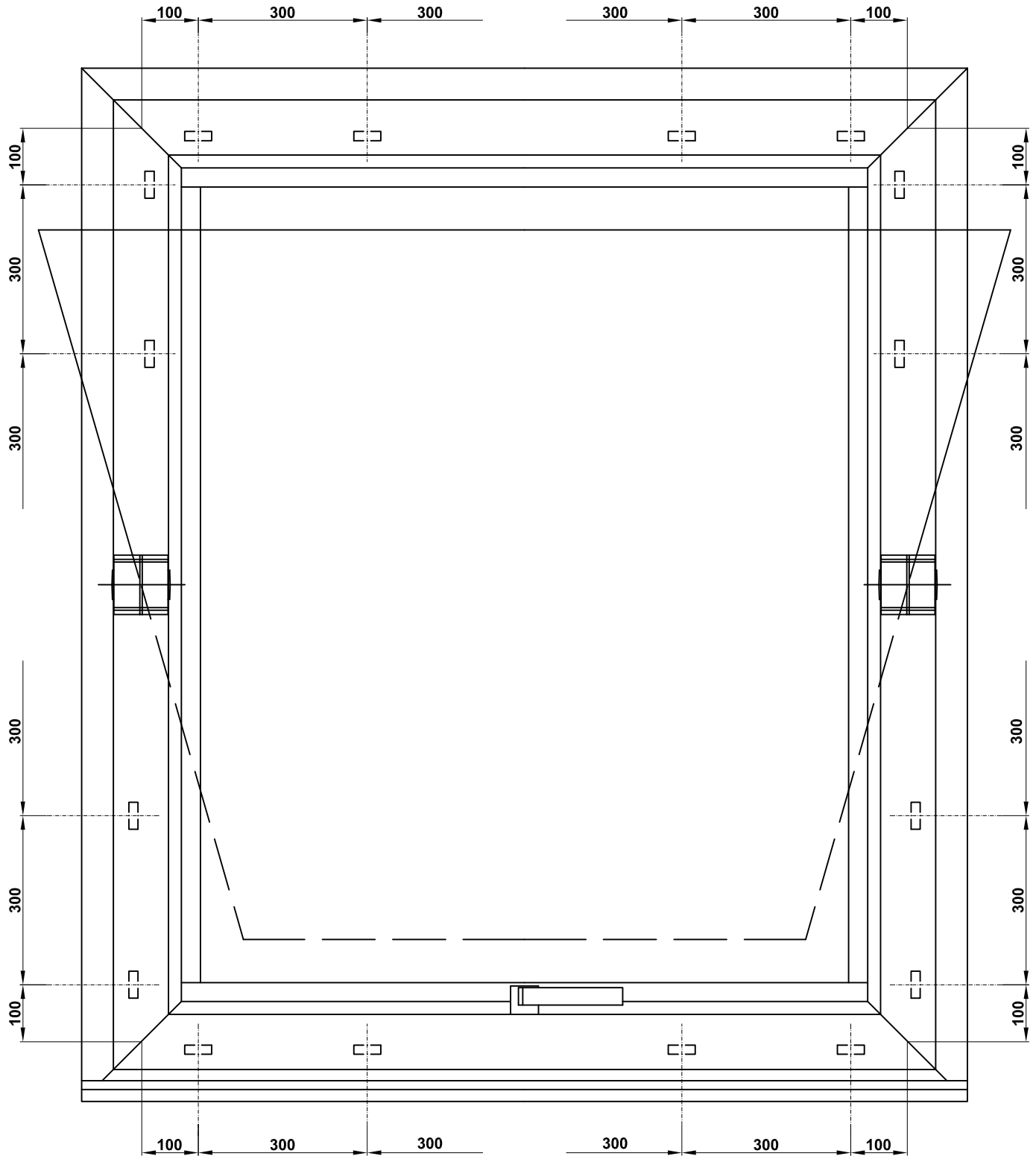

Sapa sviluppa, produce e commercializza in tutto il mondo profili a valore aggiunto. Sapa si avvale di oltre 13.000 dipendenti e centri di produzione in 30 paesi che collaborano per soddisfare tutte le esigenze dei clienti dei mercati più disparati.

Sapa Profili srl sviluppa, produce e commercializza profili per l'edilizia sempre innovativi. Original Systems garantisce una vasta e completa gamma di soluzioni residenziali e non, per rispettare le normative e per soddisfare le esigenze più complesse del mercato dell'involucro edilizio. I marchi di Original Systems, Sistema RTT, Sistema R, Teknowall, Teknowindow ed Alfil, sono distribuiti solo attraverso la rete Ufficiale di Distributori Sapa.

sapa: ... e scegli con serenità.