

R 72^{TT} 1.3
SYSTEM

R 72^{TT} 1.3 hp
SYSTEM

Sistema R^{TT}

Sistema Rtt, per porte e finestre si è arricchito dei più avanzati contenuti estetici, tecnologici e funzionali atti a soddisfare tutte le esigenze costruttive e progettuali.

Rtt System for windows and doors, has been enriched of the most esthetical, technological and functional contents to fulfill all the construction and designing demands.

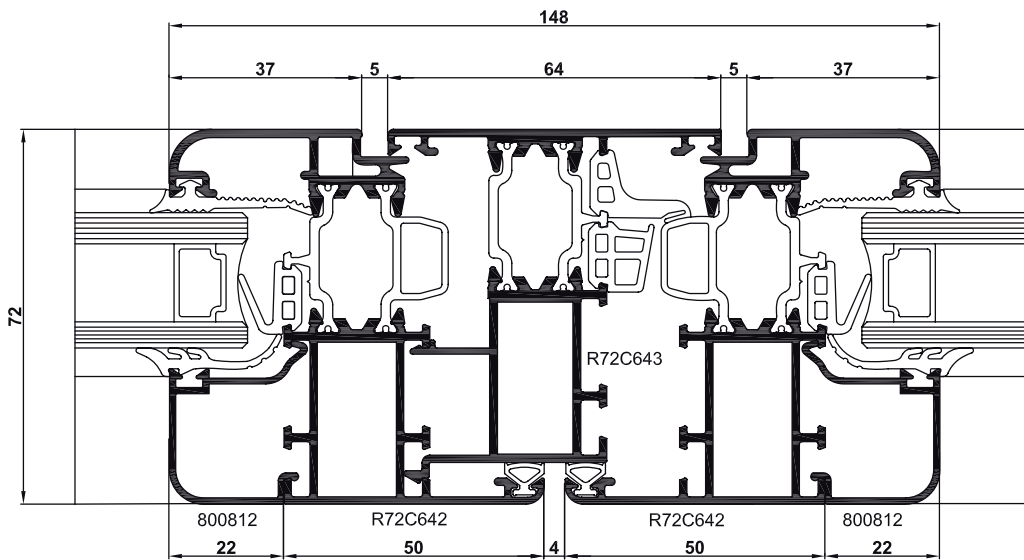

R72^{TT 1.3}
SYSTEM

R72^{TT 1.3 TE}
SYSTEM

R72^{TT 1.3 TER}
SYSTEM

Finestre e porte a battente a taglio termico
Casement windows and doors with thermal break

INDICE

INDEX

NOTE GENERALI	7
ACCESSORI E GUARNIZIONI	18
DIAGRAMMI E STATICA.....	25
FERMAVETRI.....	27
ELENCO PROFILATI	34
SEZIONI	143
DISTINTE DI TAGLIO.....	189
LAVORAZIONI.....	204

NOTE GENERALI
GENERAL NOTES

Il sistema

Il Sistema R a taglio termico è composto da sei serie di profilati: R50TT, con telaio fisso da 50 mm ed anta mobile da 58 mm R62TT, con telaio fisso da 54 mm ed anta mobile da 62 mm R72TT, con telaio fisso da 64 mm ed anta mobile da 72 mm R72TT1.3, con telaio fisso da 64 mm ed anta mobile da 72 mm R72TTCE, sistema a "Camera Europea", con telaio fisso da 64mm ed anta mobile da 72mm R85TT1.0, con telaio fisso da 75 mm ed anta mobile da 83 mm

I Profilati:

Estrusi in lega di alluminio primario da lavorazione plastica EN AW 6060 UNI-EN 573-3 sottoposti ad un processo di trattamento termico applicato secondo Normativa UNI EN 755-2 (bonifica con tempra in aria alla pressa, seguita da invecchiamento artificiale) per ottenere lo stato T66.

Trattamenti superficiali:

I trattamenti superficiali di ossidazione anodica, elettrocolorazione e di verniciatura eseguiti negli impianti di proprietà Hydro, sono nel rispetto di quanto previsto dalle normative richieste dai marchi Qualanod (per ossidazione) e Qualicoat (per la verniciatura).

Vetratura:

La scelta ed il tipo di vetro sarà in funzione del suo campo di impiego, per il montaggio attenersi scrupolosamente alle prescrizioni dei produttori. Il Sistema consente l'inserimento di vetri aventi spessori da 6 a 39 mm per R50TT ; da 10 a 43 mm per R62TT; da 20 a 53 mm per R72TT ed R72TT 1.3; da 14 a 52 per R72TT CE; da 26 a 62 per R85TT 1.0. Le guarnizioni di tenuta vetro sono in EPDM ed inseribili e sostituibili a serramento assemblato, studiate in vari spessori che, interpolati nel modo idoneo, garantiscono un'adeguata compressione sulla lastra di vetro. La tassellatura sarà effettuata con appositi tasselli di regolazione e spessoramento aventi posizioni nel serramento ideali e rinforzate. Solo la completa e totale osservanza della tecnica di vetratura potrà garantire uno scatto vincolante e sicuro del fermavetro e la garanzia di durata agli sforzi di normale utenza.

Calcolo dimensioni massime serramenti:

Nel definire le misure massime dei diversi tipi di serramento, si devono considerare oltre agli elementi costruttivi dell'infisso (sezione dei profili e loro campi d'impiego, tipo di attacco al muro, spessore e tipo del vetro), le caratteristiche di utilizzo, nonché le varianti meteorologiche (esposizione dell'infisso, velocità dei venti agenti nella zona, altezza dal suolo alla quale sarà installato l'infisso, ecc.). Consigliamo a tal fine la consultazione delle prescrizioni Uncsaal.

Attrezzature:

Le attrezzature raccomandate sono state appositamente progettate e realizzate per le particolari caratteristiche del sistema e per l'applicazione specifica degli accessori a catalogo.

Peso dei profilati:

I pesi indicati sono puramente indicativi (peso teorico ricavato sullo spessore nominale del profilato); Le matrici di estrusione sono soggette ad un normale processo di usura che porta il peso dell'estruso da un minimo (matrice nuova) ad un massimo (matrice usurata al limite delle tolleranze dimensionali).

Tolleranze dimensionali:

Per le tolleranze dimensionali si fa riferimento alla Normativa UNI EN 12020-2

Sigillature occorrenti:

Tra telaio in alluminio e controtelaio; nella vetratura esterna nell'apposita sede sopra la guarnizione di tenuta; nel tassello nodo centrale prima dell'inserimento nel profilato; nei tagli a 45° telaio ed anta prima di assiemare con squadrette; nelle giunzioni telaio ed anta.

NB:

Il mancato impiego, anche parziale, dei prodotti originali, esclude qualsiasi possibilità di rivalsa nei confronti di Hydro.

Al fine di migliorare i propri prodotti, Hydro si riserva la facoltà di apportare, in qualsiasi momento e senza preavviso, le modifiche che riterrà opportuno.

I dati riportati su questo catalogo sono indicativi e non impegnativi.

The system

The thermal break R system is made up of six series of section bars: R50TT, with 50 mm fixed frame and 58 mm moving shutter R62TT, with 54 mm fixed frame and 62 mm moving shutter R72TT, with 64 mm fixed frame and 72 mm moving shutter R72TT1.3, with 64 mm fixed frame and 72 mm moving shutter R72TTCE, "European Chamber" system, with 64 mm fixed frame and 72 mm moving shutter R85TT1.0, with 75 mm fixed frame and 83 mm moving shutter

The sections

These are extruded in primary aluminium alloy from EN AW 6060 UNI -EN 573-3 plastic manufacturing, subject to a thermal treatment, applied according to UNI EN 755-2 regulation (austempering through air tempering at the press, followed by artificial ageing) in order to achieve the T66 physical state.

Surface treatments:

The surface treatments of anodization, electrocoloration and painting carried out in Hydro Italy plants, respect the regulations required by the brands: Qualanod (for anodization) and Qualicoat (for painting).

Glazing:

The choice and the type of glass will depend on its final use. While assembling, it is essential to follow scrupulously the manufacturers' instructions. With this System it is possible to insert glass with thickness of 6 to 39 mm for R50TT; 10 to 43 mm R62TT; 20 to 53 mm for R72TT and R72TT 1.3; 14 to 52 for R72TT CE; 26 to 62 for R85TT 1.0. The weatherstrips for the glass containment is in EPDM and is conceived in different thickness. If interpolated in the correct way, it assures a proper compression on the glass. The plugging will be carried out through proper adjusting and shimming plugs, located in ideal and reinforced positions in the fastening. Only the full respect of the glazing technique will assure the proper functioning of the glass beading and will guarantee a long term resistance to the normal uses.

Window maximum dimensions

During the definition of the maximum dimensions of the different sorts of windows, beside the structural elements of the frame (section, uses, juncture to the wall, thickness and sort of glass), the final use and the weather conditions (exposure of the window frame, speed of the wind in the area, distance from the ground where the frame will be installed, etc.) have to be taken into account. To this purpose, we suggest to consult the Uncsaal regulations.

Equipment:

The recommended equipment has been planned and realized on purpose according to the particular characteristics of the system and to the specific application of the catalogue accessories.

Weight

Any weight is shown just as an indication (theoretical weight made out of the nominal thickness of the section) The extrusion dies are subject to the natural wear and tear, therefore the section weight varies from a minimum when the dies is new, to a maximum weight when the die is at highest dimensional tolerances limits.

Dimensional allowance

As for the dimensional allowance it is to refer to UNI EN 12020-2 Regulation.

Necessary sealing

Between aluminium frame and subframe; on external side of glass channel; on central node plug before inserting in the profile; in the 45° cut frame and wing before assembly with set square; in the weatherstrips frame and wing.

NB:

Hydro declines any responsibility in case of use or partial use of non original products. With the aim of improving it's products, hydro reserves the possibility to make changes to this document at any moment and with no advise. The data reported in this catalogue are indicative and not binding.

L'esecuzione del serramento dovrà prevedere tutte le operazioni necessarie per il buon funzionamento del "componente finestra" quali la sigillatura e il bloccaggio sicuro degli angoli, il fissaggio a muro adeguato e, necessariamente, l'utilizzo di accessori e guarnizioni originali. Le lavorazioni, proprio per garantire la giusta applicazione dei particolari, dovranno essere eseguite con attrezzature originali e collaudate sul sistema stesso. Gli scarichi dell'acqua e le asole di aerazione per vetri camera dovranno essere di dimensione e numero ottimale in funzione della dimensione e della tipologia del serramento.

The frame construction must include all the operations necessary for good working of the "window component", such as sealing and safe blocking of corners, suitable wall fixtures and the use of the original accessories and weatherstrips. In order to guarantee the correct application of the parts, works must be carried out with original equipment that has been tested on the system. The size and number of water drains and ventilation slots for double glazing must correspond to the size and type of window frame.

Attenzione

Nelle porte a taglio termico, nei casi in cui ci sia un'eccessiva variazione di temperatura, si possono generare, sulle ante, fenomeni di deformazione dovuta alla diversa dilatazione tra profilato esterno e profilato interno, con conseguente difficoltà di chiusura dell'anta stessa.

Ciò accade perché il sole riscalda i profilati esterni del serramento provocandone la dilatazione che risulta essere differente da quella del profilato interno non riscaldato dal sole, questo provoca delle tensioni che fanno deformare il profilato anta curvandolo verso l'interno.

Non avendo più l'allineamento anta/telaio si hanno problemi di chiusura, nelle ore di maggiore esposizione si può riscontrare il bloccaggio e/o l'impossibile chiusura della porta.

Questo fenomeno si evidenzia in particolar modo quando si hanno porte d'ingresso con tamponamenti ciechi.

Ad oggi non esistono sistemi a taglio termico che risolvano totalmente il problema. Stiamo studiando, in collaborazione con i maggiori produttori di barrette, soluzioni che possano risolvere questo fenomeno nel prossimo futuro.

Oggi, per ridurre il problema, si possono adottare accorgimenti da valutare di volta in volta.

Attention

In case of sensitive variations of temperature in the Thermal break door solution, deformation of the wings can take place due to the diversified expansion of the internal and external profiles. This can bring to a difficult closing of the wing itself.

Deformation takes place because the sun heats the external profile of the window causing a dilatation which is different from the one of the internal profile. This causes tension that curve the wing profile to the external part. As the wing and the frame are no longer aligned there could be some difficulty in closing the doors. In the hottest hours of the day the door could stall, or it could be impossible to lock the door.

This phenomena is more common when the doors have non glass clousures. Up to today there are no thermal break door systems which do not present this problem, although we are studyng alternative solutions togheter with the biggest suppliers of polyammide bars.

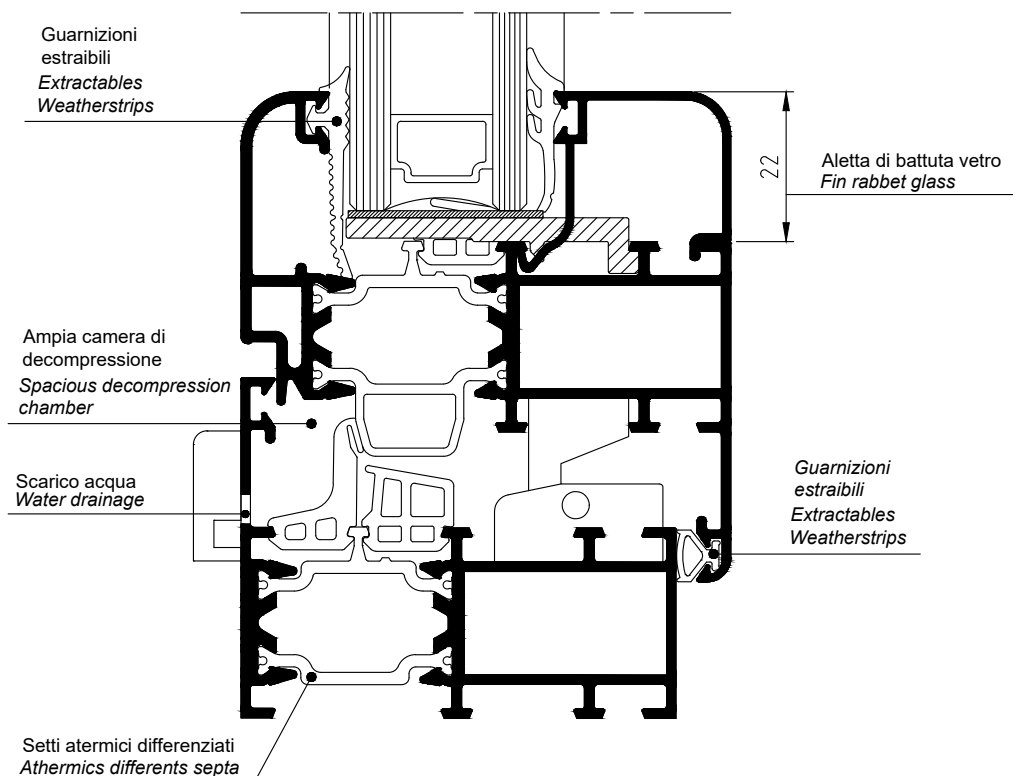

ACCESSORI E GUARNIZIONI ACCESSORIES AND PACKING

Con corpo in lega di alluminio, perni e viteria in acciaio inox, le boccole e i particolari di scorrimento sono in poliammide rinforzato. Le guarnizioni in EPDM sono state studiate con durezza differenti secondo la funzione che dovranno svolgere all'interno del serramento.

Their features are: core in aluminium alloy, pins and screw in stainless steel, bushings and sliding elements are in reinforced polyamide. The packing in EPDM has been conceived in different hardness according to its functions in the fastening.

Per garantire il massimo delle prestazioni in funzionalità e durata, il sistema RTT è stato sottoposto ai collaudi rescritti dalle vigenti Normative europee ottenendo ottimi risultati

To guarantee the maximum functionality and wear, RTT system has been tested according to the running european norms.

CERTIFICATI

CERTIFICATES

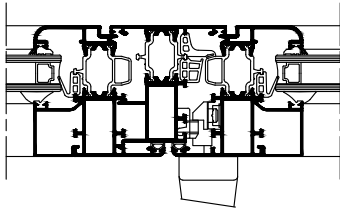
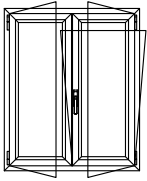
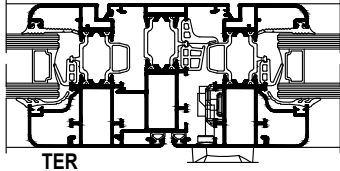
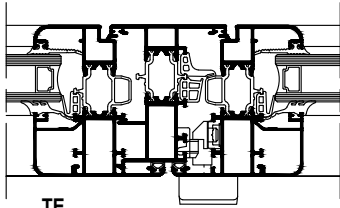
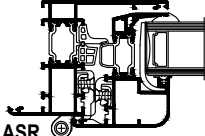
Sistema System	Tipologia Windows and doors	Dimensioni Dimensions L x H mm	Risultati prove Test values			Sezioni Cross section	Laboratorio Certificato N° Laboratory Certificate Nr.
			Aria Air	Acqua Water	Vento Wind		
FINESTRA A 2 ANTE							
R 72 TT 1.3 SYSTEM							IRCCOS 1994-CPR RP1470
R 72 TT 1.3 SYSTEM Tubolari Esterni Ridotti		1544 x 1644	4	E1500	C5		IRCCOS RT-174-2017
R 72 TT 1.3 SYSTEM Tubolari Esterni							IRCCOS RT-177-2017
R 72 TT 1.3 SYSTEM Anta a Scomparsa Ridotta							IRCCOS RT-187-2017

PORTA A BALCONE A 3 ANTE

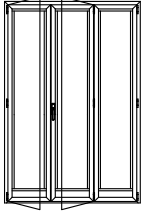
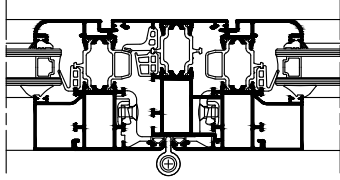
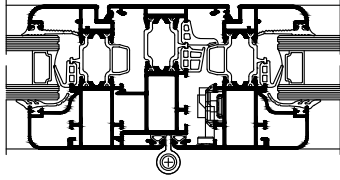
R 72 TT 1.3 SYSTEM		1844 x 2244	4	E750	C2		2098 / 2010 - B
R 72 TT 1.3 SYSTEM Tubolari Esterni Ridotti							

N.B. I risultati del RP 2098/2010-B sono estendibili alla versione R72TT con TER per il caso finestra a tre ante.

- Collaudi eseguiti, in conformità alla Norma UNI EN 1026 - UNI EN 1027 - UNI EN 12211
- Collaudi classificati secondo Normative UNI EN 12207 - UNI EN 12208 - UNI EN 12210

- Tests Execute as UNI EN 1026 - UNI EN 1027 - UNI EN 12211 standards
- Tests Classify as UNI EN 12207 - UNI EN 12208 - UNI EN 12210 standards

Per garantire il massimo delle prestazioni in funzionalità e durata, il sistema RTT è stato sottoposto ai collaudi prescritti dalle vigenti Normative europee ottenendo ottimi risultati

To guarantee the maximum functionality and wear, RTT system has been tested according to the running european norms.

CERTIFICATI

CERTIFICATES

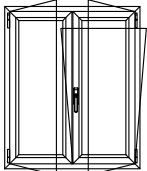
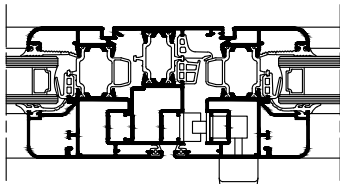
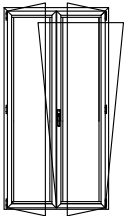
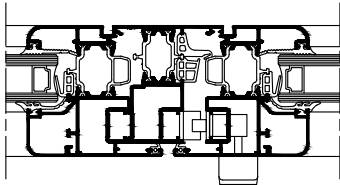
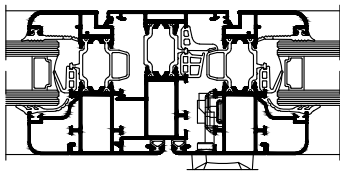
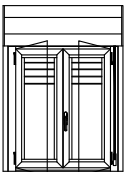
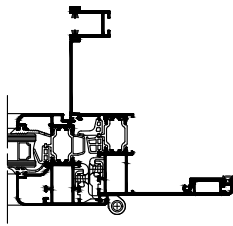
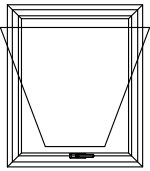
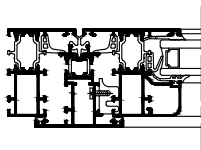
Sistema System	Tipologia Windows and doors	Dimensioni Dimensions L x H mm	Risultati prove Test values			Sezioni Cross section	Laboratorio Certificato N° Laboratory Certificate Nr.
			Aria Air	Acqua Water	Vento Wind		
R 72 TT 1.3 SYSTEM Pista 16		1544 x 1644	FINESTRA A 2 ANTE 4 E1200 C4				ISTEDIL 2098/2010-D
R 72 TT 1.3 SYSTEM Pista 16		1644 x 2244	PORTA A BALCONE A 2 ANTE 4 E900 C3				ISTEDIL 1508/2011-B
R 72 TT 1.3 SYSTEM Tubolari Esterni Ridotti							
N.B. I risultati del 1508/2011 - B sono estendibili alla versione R72TT con TER per il caso finestra a balcone a due ante.							
R 72 TT 1.3 SYSTEM Monoblocco		1610 x 1705	FINESTRA A 2 ANTE 4 E1500 C5				IRCCOS RT-204-2018
R 72 TT 1.3 SYSTEM Bilico orizzontale		1644 x 224	BILICO ORIZZONTALE 4 7A C5				0355/2014/E

- Collaudi eseguiti, in conformità alla Norma UNI EN 1026 - UNI EN 1027 - UNI EN 12211
- Collaudi classificati secondo Normative UNI EN 12207 - UNI EN 12208 - UNI EN 12210

- Tests Execute as UNI EN 1026 - UNI EN 1027 - UNI EN 12211 standards
- Tests Classify as UNI EN 12207 - UNI EN 12208 - UNI EN 12210 standards

Tecnicamente, viene definito "a taglio termico" un profilato metallico che, una volta impiegato nella costruzione di un infisso, presenti il lato rivolto all'interno nettamente diviso dal lato esposto all'esterno per impedire lo scambio termico. Le due parti della sezione devono essere perciò separate da un materiale diverso, con bassi valori di conducibilità termica.

Il taglio termico del sistema R, realizzato con barrette in poliammide rinforzato, si colloca su bassi valori di trasmittanza termica, in linea con i sistemi a taglio termico più avanzati.

Per evitare slittamenti dei vari componenti del profilato a taglio termico è prescritta la pre-zigrinatura dei particolari di bloccaggio prima dell'operazione meccanica di accoppiamento.

A metal section which, when used in the construction of a frame, has the side facing inwards clearly divided from that facing outwards to prevent heat exchange is technically defined "with thermal break". The two parts of the section must therefore be separated by a different material, with low conductivity values.

The thermal break of the R system, produced with reinforced polyamide bars, is placed on low k values (heat transmission coefficient), in line with the most advanced systems with thermal break.

To prevent the components of the thermal break section from slipping, it is advisable to pre-knurl the blocking parts before carrying out the mechanical coupling operation.

Tutti i profilati a taglio termico venduti da Hydro sono sempre riconoscibili.

Il marchio, impresso a laser è stato previsto per essere sempre visibile nel profilato assemblato come dalla figura sottostante.

All thermal break sections are always recognizable.

The laser impressed brand is always visible on the assembled sections as you can see in the picture here under.

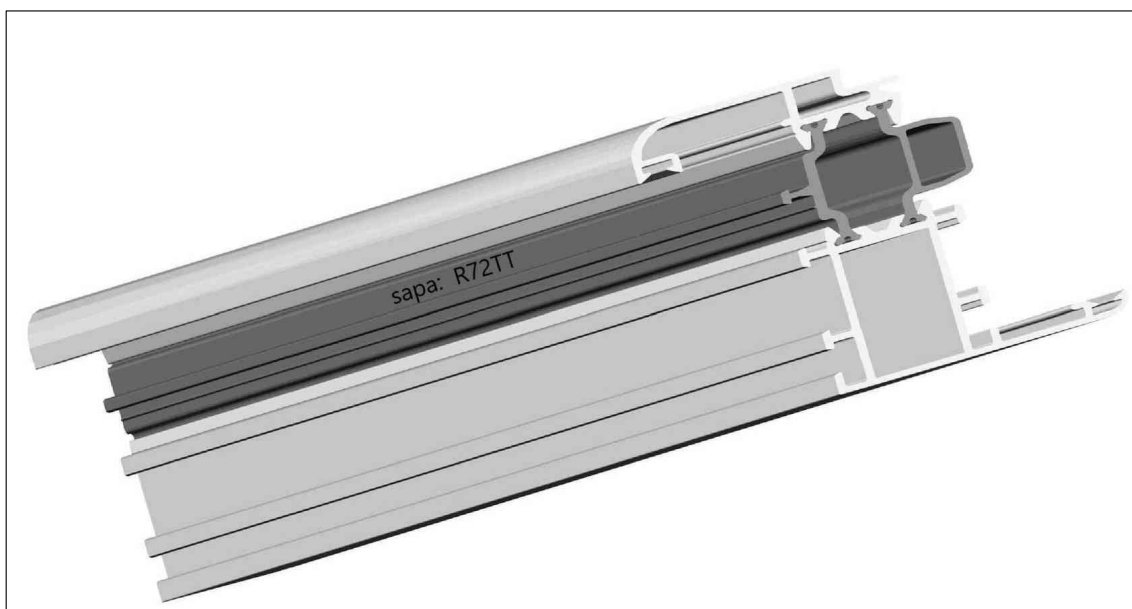

Hydro non risponde di eventuali difetti imputabili ad accoppiamenti non eseguiti nei propri stabilimenti e/o dovuti all'utilizzo di macchine non idonee e/o mal regolate.

Hydro will not be responsible for any incidental defects due to couplings which have not been carried out in its own premises and/or due to the use of not proper and/or not well-regulated machines.

CONFIGURAZIONE STANDARD
STANDARD CONFIGURATION

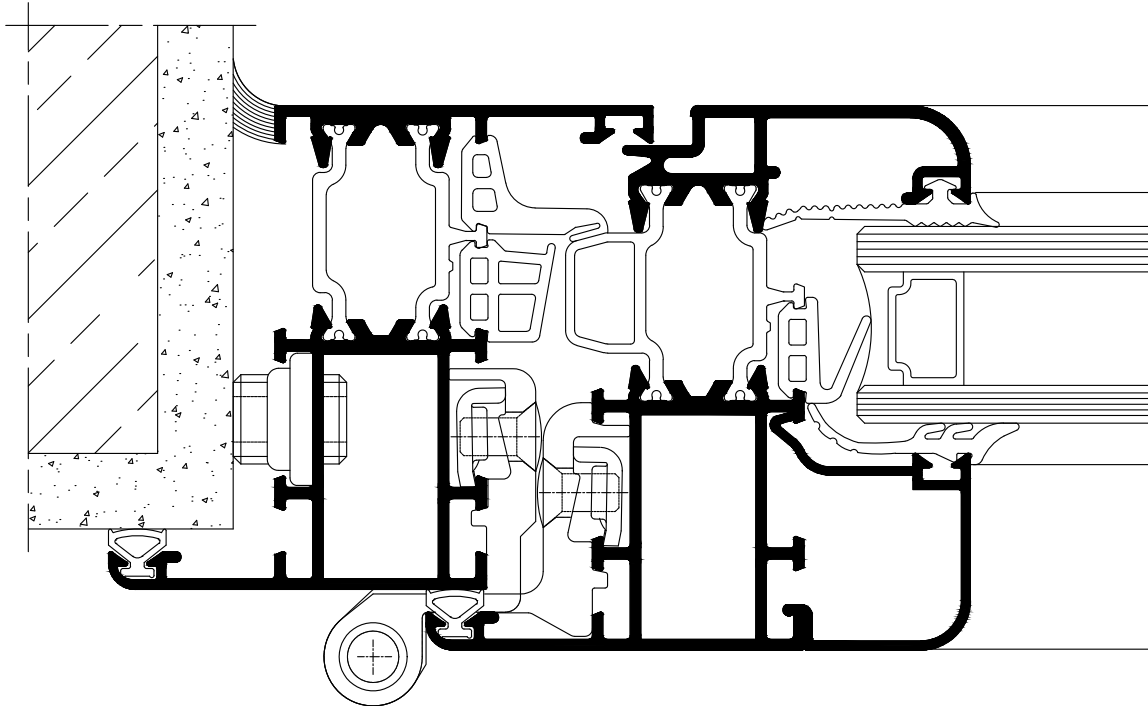

CONFIGURAZIONE hp
CONFIGURATION hp

Inserire all'interno delle barrette, sotto il vetro ed a contatto con la muratura, il materiale isolante come indicato nello schema sottostante.

Insert the isolating material in the poliammide bars, under the glass and in contact with the wall, as indicated in the scheme.

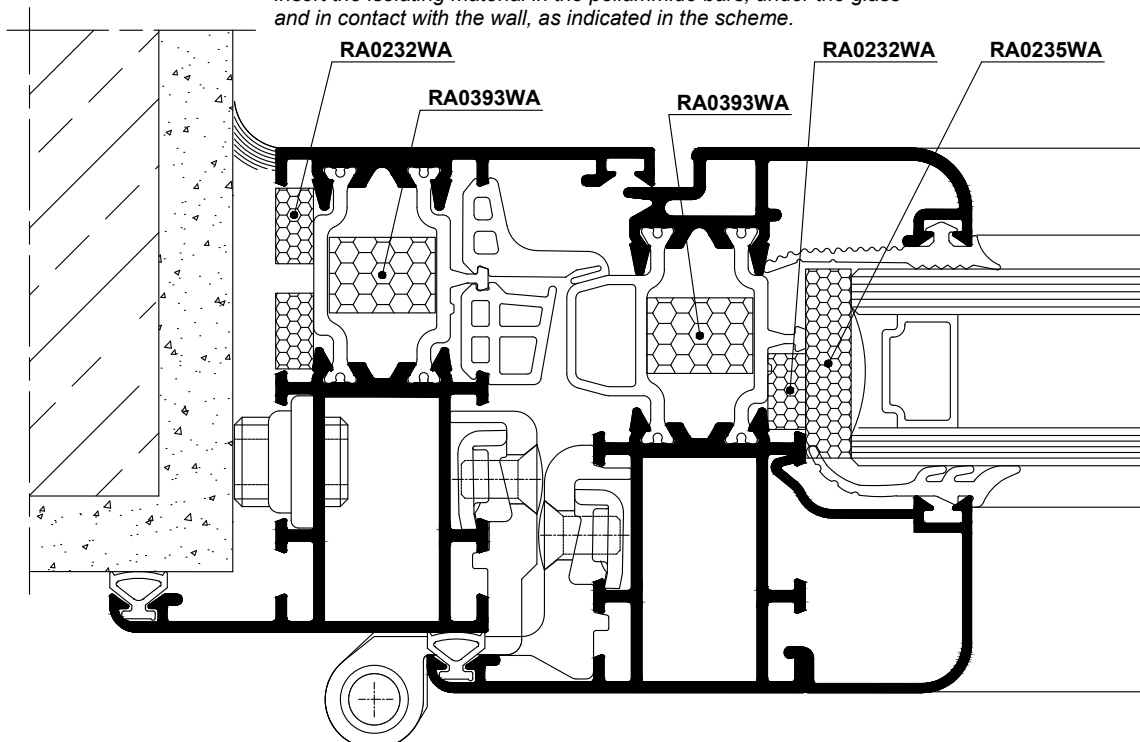

In materia di efficienza energetica la Comunità Europea ha indicato ai Paesi membri la strada da percorrere con la Direttiva 2002/91/CE "Rendimento energetico nell'edilizia" detta anche EPBD, ovvero Energy Performance Buildings Directive successivamente aggiornata con la Direttiva 2010/31/UE (detta anche EPBD2) in vigore dal 9 luglio 2010.

L'Italia introduce nel proprio regolamento nazionale le indicazioni delle due direttive attraverso il DLgs 192/05 (di recepimento della direttiva 2002/91) e il Decreto Legge 63/13 (di recepimento della direttiva 2010/31) convertito in legge il 3 agosto 2013 dalla Legge 90/13. L'ultimo atto dell'evoluzione legislativa nazionale riguarda la pubblicazione a luglio 2015 del decreto attuativo della Legge 90/13 ovvero il Decreto Ministeriale del 26 giugno 2015.

Attualmente sono in vigore i seguenti decreti e leggi: DLgs 192/05 + DLgs 311/06 + DLgs 28/11 + DL 63/13 + L90/13 + DM 26/06/15

I decreti attuativi contenuti nel DM 26/6/15 riguardano i seguenti 3 argomenti:

- **DM requisiti minimi:** prescrizioni e requisiti da rispettare nonché definizione dell'edificio ad energia quasi zero;
- **Linee Guida Nazionali per la certificazione energetica:** modalità di classificazione e nuovo modello di attestato di certificazione energetica;
- **Nuovi modelli per la relazione tecnica.**

Le disposizioni dei decreti attuativi della Legge 90/13 si applicano alle Regioni e alle Provincie autonome che non hanno ancora adottato provvedimenti di recepimento della Direttiva 2010/31/UE. Le Regioni che hanno già recepito la direttiva europea hanno due anni di tempo per uniformarsi ai provvedimenti nazionali.

Le esclusioni:

Secondo il DLgs 192/05 modificato dalla Legge 90/13, sono esclusi dall'applicazione del decreto le seguenti categorie di edifici:

- Immobili con vincoli storici, artistici o paesaggistici;
- Fabbricati industriali, artigianali ed agricoli riscaldati per esigenze del processo produttivo o utilizzando reflui energetici del processo produttivo non altrimenti utilizzabili;
- Fabbricati isolati con una superficie totale inferiore a 50m²;
- Edifici rurali non residenziali sprovvisti di impianti di climatizzazione;
- Edifici adibiti a luogo di culto e allo svolgimento di attività religiose.

Inoltre in base al DM 26/6/15 i seguenti interventi sono esclusi dall'applicazione dei requisiti minimi:

- Interventi su strati di finitura ininfluenti dal punto di vista termico;
- Rifacimento di porzioni di intonaco su superfici <10% della superficie disperdente.

Secondo il DM 26/6/15 sono identificati i seguenti tipi di intervento:

- **Nuova costruzione.** Edificio il cui titolo abilitativo è stato richiesto dopo l'entrata in vigore del DM 26/06/15 (*ndr, ovvero dal 1° ottobre 2015*);

Sono assimilati a nuova costruzione anche gli interventi di

- ✓ **Demolizione e ricostruzione;**

- ✓ **Ampliamento di edifici esistenti** (dotati di nuovi impianti tecnici) per il quale valga almeno una delle seguenti condizioni: nuovo volume lordo climatizzato > 15% volume lordo climatizzato esistente o nuovo volume lordo climatizzato > 500m³.

- **Ristrutturazione importante di primo livello.** La ristrutturazione prevede contemporaneamente:

- ✓ un intervento che interessa l'involucro edilizio con un'incidenza > 50% della superficie disperdente lorda complessiva dell'edificio;
- ✓ la ristrutturazione dell'impianto termico per il servizio di climatizzazione invernale e/o estiva asservito all'intero edificio.

In tal caso i requisiti di prestazione energetica si applicano all'intero edificio.

- **Ristrutturazione importante di secondo livello.** L'intervento interessa l'involucro edilizio con un'incidenza > 25% sulla superficie disperdente lorda e può interessare l'impianto termico per il servizio di climatizzazione invernale e/o estiva;

- **Riqualificazione energetica.** Sono tutti quegli interventi non riconducibili ai casi precedenti e che hanno comunque un impatto sulla prestazione energetica dell'edificio. In particolare la riqualificazione energetica dell'involucro riguarda interventi che coinvolgono una superficie ≤ 25% della superficie disperdente lorda complessiva.

Per quanto riguarda la ristrutturazione importante di secondo livello e la riqualificazione energetica è necessario verificare che:

- Trasmissione chiusure tecniche trasparenti o opache ≤ valori limite.

Inoltre si deve verificare che per le chiusure tecniche trasparenti delimitanti il volume climatizzato verso l'esterno con orientamento da Est a Ovest, passando per Sud: $g_{gl}+sh \leq 0,35$. Dove $g_{gl}+sh$ è il valore del fattore di trasmissione solare totale della componente finestrata, quando la schermatura solare è utilizzata.

Per le chiusure tecniche trasparenti quindi le tabelle di riferimento sono le seguenti:

Trasmissione termica U_w massima delle chiusure tecniche trasparenti e opache e dei cassonetti, comprensivi degli infissi, verso l'esterno e verso ambienti non climatiz. soggetti a riqualificazione		
Zona climatica	Ulimite [W/m ² K]	
	Dal 1° ottobre 2015	Dal 1° gennaio 2021
A - B	3,20	3,00
C	2,40	2,00
D	2,10	1,80
E	1,90	1,40
F	1,70	1,00

Valore del fattore di trasmissione solare totale ggl+sh per componenti finestrati con orientamento da Est a Ovest passando per Sud, in presenza di una schermatura mobile		
Zona climatica	ggl+sh [-]	
	Dal 1° ottobre 2015	Dal 1° gennaio 2021
Tutte	0,35	0,35

Alcune regioni hanno legiferato per anticipare i tempi di entrata in vigore dei decreti attuativi contenuti nel DM 26/6/15. Si raccomanda di verificare per le singole regioni, i valori limite da rispettare.

Una corretta posa in opera, evita spesso il decadimento delle prestazioni ottenute in laboratorio, curare in maniera appropriata la posa valorizza tutto il processo produttivo dalla progettazione all'installazione. Fare una pulizia periodica con prodotti neutri riduce notevolmente i rischi di corrosione ed allunga sicuramente la vita dell'infisso.
Per una corretta installazione, manutenzione e pulizia dei serramenti, Vi raccomandiamo di consultare le prescrizioni riportate sulle seguenti note tecniche UNCSAAL:
UX42 - "Guida alla posa in opera dei serramenti"
UX10 - "La pulizia delle superfici di serramenti e facciate continue"

A correct installation, often avoids the decay of the performances obtained in the laboratory. Taking appropriate care of the installation increases the value of the whole production process from the planning to the installation.
Cleaning periodically with neutral products reduces remarkably the corrosion risk and extends surely the life of the frame.
For a correct installation, maintenance and cleaning of the sections, we recommend you refer to the prescriptions quoted in the following technical notes of UNCSAAL UX42 and UX10













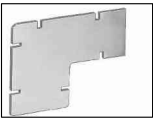





LEGHE IN ALLUMINIO DA BONIFICA - PROFILATI ESTRUSI HEAT-TREATABLE ALUMINIUM ALLOYS - EXTRUSION SECTIONS

Leghe / Alloys		6060 UNI EN 573-3				
Composizione chimica normale / Normal chemical compos		Mg 0,4 Si 0,4 Fe 0,2				
Stato / State		0	T1	T5	T6	
Caratteristiche meccaniche <i>Mechanical Characteristics</i>	Carico di rottura a trazione <i>Ultimate tensile stress</i>	R _m N/mm ²	140 Max	120	185	205
	Carico al limite di snervamento <i>Yield point</i>	R _p N/mm ²	80 Max	50	145	165
	Allungamento <i>Elongation</i>	A %	20	16	11	10
Caratteristiche fisiche <i>Physical Characteristics</i>	Peso specifico <i>Specific weight</i>	Kg/dm ³	2,70			
	Conduttività termica a 20°C <i>Heat conductivity at 20°C</i>	W/ (cm °K)	≈ 2,09		≈ 1,75	
	Resistività elettrica a 20°C <i>Electrical resistivity at 20°C</i>	μΩ ·cm	≈ 3,14		≈ 3,25	
	Coef. di dilatazione termica lineare da 20° a 200°C <i>Linear thermal expansion coefficient from 20° to 200° C</i>		24 ·10 ⁻⁶ K ⁻¹			

ACCESSORI E GUARNIZIONI
ACCESSORIES AND GASKETS

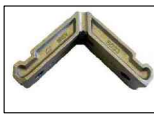
SQUADRETTE D'ANGOLO
CORNER JOINTS

SQUADRETTE D'ANGOLO
CORNER JOINTS

Articolo Item	Immagine Picture	Descrizione Description	Articolo Item	Immagine Picture	Descrizione Description
RA2919NN		Squadretta d'allineamento in nylon su aletta. <i>Nylon alignment corner joint on fin.</i>	RA3102AA		Squadretta d'allineamento profilati mostra <i>Alignment corner joint profiles cornice</i>
		R50TT R62TT R72TT R72TTCE R72TT1.3 R85TT1.0			R50TT R62TT R72TT R72TTCE R72TT1.3 R85TT1.0
RA2920NN		Squadretta d'allineamento in nylon per profili complanari ed arrotondati. <i>Nylon alignment corner joint for coplanar and rounded profiles.</i>	RA4411AA		Squadretta in alluminio estruso per tubolarità 10,4x42 <i>Extruded aluminium corner joint piping 10,4x42</i>
		R50TT R62TT R72TT R72TTCE R72TT1.3 R85TT1.0			R50TT R62TT R72TT R72TTCE R72TT1.3 R85TT1.0
RA5624AA		Squadretta d'allineamento a cianfrinare in alluminio per tubolarità 27x6.8 <i>Aluminium alignment corner joint for caulking for piping 27x6.8</i>	RA5411AA		Squadretta in alluminio estruso per tubolarità 15 x 25 <i>Extruded aluminium corner joint piping 15 x 25</i>
		R50TT R62TT R72TT R72TTCE R72TT1.3 R85TT1.0			R50TT R62TT R72TT R72TTCE R72TT1.3 R85TT1.0
RA5662AA		Squadretta a cianfrinare per profili con tubolarità 6,7x7,5 <i>Crimped corner joint for profiles piping 6.7x7.5</i>	RA5429AA		Squadretta in alluminio estruso per profili maggiorati 38.8x29.2 <i>Extruded aluminium corner joint for oversized profiles piping 38.8x29.2</i>
		R50TT R62TT R72TT R72TTCE R72TT1.3 R85TT1.0			R50TT R62TT R72TT R72TTCE R72TT1.3 R85TT1.0
RA3104BA		Squadretta d'allineamento aletta esterna "FUJI" <i>Alignment corner joint for external rabbet "FUJI"</i>	RA5441AA		Squadretta in alluminio estruso con inserto unificato per tubolarità 15x29.2 <i>Extruded aluminium corner joint with unified ins. piping 15x29.2</i>
		R50TT R62TT R72TT R72TTCE R72TT1.3 R85TT1.0			R50TT R62TT R72TT R72TTCE R72TT1.3 R85TT1.0
RA3105BA		Squadretta d'allineamento profilati complanari "FUJI" <i>Alignment corner joint profiles complanarities "FUJI"</i>	RA2921AA		Squadretta esterna a cianfrinare per tubolarità 16,8x7 <i>External corner joint for crimped 16,8x7</i>
		R50TT R62TT R72TT R72TTCE R72TT1.3 R85TT1.0			R50TT R62TT R72TT R72TTCE R72TT1.3 R85TT1.0
RA2930AA		Squadretta d'allineamento aletta interna "FUJI" <i>Alignment corner joint for internal rabbet "FUJI"</i>	RA2922AA		Squadretta cianfrinare e spinare per tubolari esterni <i>Crimping/pin corner cleat for external tubulars</i>
		R50TT R62TT R72TT R72TTCE R72TT1.3 R85TT1.0			
RA2932BA		Squadretta d'angolo interno profilato RR72C704 <i>Corner joint for internal profile RR72C704</i>	RA2923AA		Squadretta cianfrinare e spinare per tubolari esterni maggiorati <i>Crimping/pin corner cleat for reinforced external tubulars</i>
		R50TT R62TT R72TT R72TTCE R72TT1.3 R85TT1.0			
RA9945VV		Vite per squadretta RA2932BA <i>Screw for corner joint RA2932BA</i>	RA2929KA		Spina per squadrette RA2922AA, RA2923AA, RA2931BA <i>Pin for corner cleats RA2922AA, RA2923AA, RA2931BA</i>
		R50TT R62TT R72TT R72TTCE R72TT1.3 R85TT1.0			

SQUADRETTE D'ANGOLO
CORNER JOINTS

SQUADRETTE D'ANGOLO
CORNER JONTS

Articolo Item	Immagine Picture	Descrizione Description	Articolo Item	Immagine Picture	Descrizione Description
RA2906AA		Squadretta a cianfrinare per profili con tubolarità 15x29,5mm <i>Crimped corner joint for profiles piping 15x29,5mm</i>	RA2912AA		Squadretta esterna a cianfrinare tubolarità 15,4x10,4 <i>External corner joint to be crimped 15,4x10,4</i>
		R50TT R62TT R72TT R72TTCE R72TT1.3 R85TT1.0			R72TT1.3
RA2915AA		Squadretta d'angolo per profilato RR72C115 (tubolarità 15x24,7) <i>Corner joint for profile RR72C115 (piping mm 15x24,7)</i>	RA3103ZA		Squadretta allineamento aletta anta soluzione ferramenta perimetrale <i>Alignment corner joint for rabbet wing perimetral fitting solution</i>
		R50TT R62TT R72TT R72TT1.3			R72TTCE R72TT1.3
0496 (Monticelli)		Squadretta d'angolo per profilato RR72C748 tubolarità 35,9x29,1 <i>Corner joint for profile RR72C748 piping mm 35,9x29,1</i>	RA2931BA		Squadretta a cianfrinare, spinare e avvitare per profili con tubolarità 6,7x7,5mm <i>Corner joint for piping, crimped and screw to profiles 6,7x7,5mm</i>
		R72TTCE R72TT1.3			R50TT R62TT R72TT R72TTCE R72TT1.3 R85TT1.0
RA2935BA		Squadretta in alluminio estruso tubolarità 15x29,1 <i>Extruded aluminium corner joint. piping 15x29,1</i>	5043 (Monticelli)		Squadretta in alluminio estruso a cianfrinare, spinare e avvitare per profili maggiorati 38,8x29,2mm <i>Extruded aluminium corner joint for piping, crimped and screw to profiles 38,8x29,2mm</i>
		R72TTCE R72TT1.3			R50TT R62TT R72TT R72TT1.3 R85TT1.0
RA2911AA		Squadretta esterna ad avvitare tubolarità 15,4x10,4 <i>External corner joint to be screw 15,4x10,4</i>	5034 (Monticelli)		Squadretta in alluminio estruso a cianfrinare, spinare e avvitare con inserto unificato per tubolarità 15x29,2mm <i>Extruded aluminium corner joint for piping, crimped and screw to profiles 15x29,2mm</i>
		R72TT1.3			R50TT R62TT R72TT R72TT1.3 R85TT1.0
RA2914AA		Squadretta esterna per tubolarità 39,2x10,4 <i>External corner joint to 39,2x10,4</i>	RA3204ZX		Cavallotto di giunzione telai-traversi (Destro). <i>T-joint for frames and transoms (Right).</i>
		R72TT1.3			R50TT R62TT R72TT R72TTCE R72TT1.3 R85TT1.0
2019 (Monticelli)		Squadretta d'allineamento aletta "FUJI" <i>Alignment corner joint for rabbet "FUJI"</i>	RA3204ZY		Cavallotto di giunzione telai-traversi (Sinistro). <i>T-joint for frames and transoms (Left).</i>
		R72TTCE R72TT1.3			R50TT R62TT R72TT R72TTCE R72TT1.3 R85TT1.0
R2021		Squadretta d'allineamento aletta "FUJI" <i>Alignment corner joint for rabbet "FUJI"</i>	RA3205NN		Giunto per tubolari esterni <i>Joint for external tubular</i>
		R72TTCE R72TT1.3			R72TT1.3
RA2910AA		Squadretta esterna a cianfrinare e spinare per tubolarità 12x7,5 <i>External corner joint for piping and crimped 12x7,5</i>	RA3206NN		Giunto per tubolari esterni maggiorati <i>Joint for external big tubular</i>
		R72TTCE R72TT1.3			R72TT1.3

**TAPPI
PLUGS**

Articolo Item	Immagine Picture	Descrizione Description	Articolo Item	Immagine Picture	Descrizione Description												
RA3207AA		Giunto in alluminio estruso. <i>Extruded aluminium joint.</i>	RA2132NN		Coppia tappi per battuta centrale per apertura esterna su profilo R2R72C38. <i>Pair of plugs for central rabbet for external opening on profile R2R72C38.</i>												
		<table border="1"><tr><td>R50TT</td><td>R62TT</td><td>R72TT</td></tr><tr><td></td><td>R72TT1.3</td><td>R85TT1.0</td></tr></table>	R50TT	R62TT	R72TT		R72TT1.3	R85TT1.0			<table border="1"><tr><td></td><td>R62TT</td><td>R72TT</td></tr><tr><td></td><td>R72TT1.3</td><td></td></tr></table>		R62TT	R72TT		R72TT1.3	
R50TT	R62TT	R72TT															
	R72TT1.3	R85TT1.0															
	R62TT	R72TT															
	R72TT1.3																
RA2116TN		Tappo aggiuntivo in nylon su profilo RR72C684 in abbinamento con i tappi cod. RA2127TN <i>Nylon additional plug for section RR72C684 to combine to cod. RA2127TN</i>	RA2180TN		Coppia tappi riporto centrale su RR72C778 <i>Pair of plugs on profile RR72C778</i>												
		<table border="1"><tr><td>R50TT</td><td>R62TT</td><td>R72TT</td></tr><tr><td></td><td>R72TT1.3</td><td>R85TT1.0</td></tr></table>	R50TT	R62TT	R72TT		R72TT1.3	R85TT1.0									
R50TT	R62TT	R72TT															
	R72TT1.3	R85TT1.0															
RA2127TN		Coppia tappi battuta centrale su RR72C643 <i>Pair of plugs on profile RR72C643</i>	RA2160NN		Tappo chiudi feritoia tra montante e traverso <i>Plug for mullion and transom</i>												
		<table border="1"><tr><td></td><td>R72TT1.3</td><td></td></tr></table>		R72TT1.3				<table border="1"><tr><td>CE72TT</td><td>R72TT 1.3</td><td></td></tr></table>	CE72TT	R72TT 1.3							
	R72TT1.3																
CE72TT	R72TT 1.3																
RA2137TN		Coppia tappi battuta centrale su RR72C729 <i>Pair of plugs on profile RR72C729</i>	RA2162TN		Tappi laterali cassonetto ispezionabile <i>Lateral plugs for inspectable rolling shutter box</i>												
		<table border="1"><tr><td>R72TTCE</td><td>R72TT1.3</td><td></td></tr></table>	R72TTCE	R72TT1.3				<table border="1"><tr><td>CE72TT</td><td>R72TT 1.3</td><td></td></tr></table>	CE72TT	R72TT 1.3							
R72TTCE	R72TT1.3																
CE72TT	R72TT 1.3																
RA2138TN		Coppia tappi battuta centrale su RR72C737 <i>Pair of plugs on profile RR72C737</i>	RR950001		Aggancio fermavetri arrotondati. <i>Rounded glass beading coupling.</i>												
		<table border="1"><tr><td></td><td>R72TT1.3</td><td></td></tr></table>		R72TT1.3				<table border="1"><tr><td>R50TT</td><td>R62TT</td><td>R72TT</td></tr><tr><td></td><td>R72TT1.3</td><td>R85TT1.0</td></tr></table>	R50TT	R62TT	R72TT		R72TT1.3	R85TT1.0			
	R72TT1.3																
R50TT	R62TT	R72TT															
	R72TT1.3	R85TT1.0															
RA2163NN		Coppia tappi aggiuntivi su profilato R2R72C38 in abbinamento con RA2132NN <i>Additional pair plugs for section R2R72C38 to combine to cod. RA2132NN</i>	RA0240BA		Angolo per fermavetri stampato. <i>Molded corner for glazing bead.</i>												
		<table border="1"><tr><td></td><td></td><td>R72TT</td></tr><tr><td></td><td>R72TT1.3</td><td></td></tr></table>			R72TT		R72TT1.3				<table border="1"><tr><td></td><td></td><td>R72TT</td></tr><tr><td></td><td>R72TT1.3</td><td></td></tr></table>			R72TT		R72TT1.3	
		R72TT															
	R72TT1.3																
		R72TT															
	R72TT1.3																
RA2143NN RA2143NB		Tappo aggiuntivo in nylon per profilo RR72C676 in abbinamento con i tappi cod. RA2127TN <i>Nylon additional plug for section RR72C676 to combine to cod. RA2127TN</i>															
		<table border="1"><tr><td>R50TT</td><td>R62TT</td><td>R72TT</td></tr><tr><td></td><td>R72TT1.3</td><td>R85TT1.0</td></tr></table>	R50TT	R62TT	R72TT		R72TT1.3	R85TT1.0									
R50TT	R62TT	R72TT															
	R72TT1.3	R85TT1.0															

Articolo Item	Immagine Picture	Descrizione Description	Articolo Item	Immagine Picture	Descrizione Description
------------------	---------------------	----------------------------	------------------	---------------------	----------------------------

SPESSORAMENTO VETRI
SHIM FOR GLASSES

RA2804AA



Supporto per spessoramento vetri
Glass support

	R72TT1.3	
--	----------	--

RA9943VV

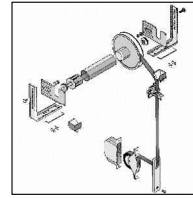

Kit accessori per monoblocco, composto da:

- Avvolgitore con cinghia
- Porta avvolgitore
- Supporti ad "L"
- Piastre di supporto (coppia)
- Cuscinetti in nylon
- Calotta rullo con perno

Accessory kit for monoblock consist of:

- Winder with tape
- Winder holder
- "L" support

- Support plates (couple)
- Nylon roller-bearing
- Roller cover with pin

RA2833AA



Supporto ed appoggio vetro per "Cartelline tubolari esterne"
Glass support to "External tubolar"

	R72TT1.3	R85TT1.0
--	----------	----------

Il disegno è puramente indicativo
This drawing is indicative

CE72TT	R72TT 1.3	
--------	-----------	--

RA2834AA



Supporto ed appoggio vetro
Glass support

	R62TT	R72TT
	R72TT1.3	

RA9942AA

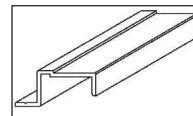

Fissaggio cassonetto su traverso
Fixing of the roller shutting box on the transom

CE72TT	R72TT 1.3	
--------	-----------	--

42510055 (Alutec)



Coppia inviti tapparella
Couple of guides for rolling shutter

CE72TT	R72TT 1.3	
--------	-----------	--

ZEX18326 (Comall)

Dima di foratura per spina
RA2929KA
Drilling jig for pin RA2929KA
* Non commercializzato da Original Systems

RA5532NN



Cappetta foro drenaggio acqua
Drainage cap



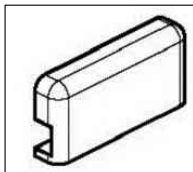













RA5753NV



Cappetta foro drenaggio acqua
Drainage cap













**GUARNIZIONI
WEATHERSTRIPS**

**GUARNIZIONI
WEATHERSTRIPS**

Articolo Item	Immagine Picture	Descrizione Description	Articolo Item	Immagine Picture	Descrizione Description												
RG0119EN		Guarnizione di battuta per bilico <i>Pivoting weatherstrip of rabbet</i> E.P.D.M. <table border="1"><tr><td>R50TT</td><td>R62TT</td><td></td></tr><tr><td></td><td>R72TT1.3</td><td></td></tr></table>	R50TT	R62TT			R72TT1.3		RG0134EN		Guarnizione appoggio esterno vetri da 3 mm <i>mm 3 glass support weatherstrip</i> E.P.D.M. <table border="1"><tr><td>R50TT</td><td>R62TT</td><td>R72TT</td></tr><tr><td>R72TTCE</td><td>R72TT1.3</td><td>R85TT1.0</td></tr></table>	R50TT	R62TT	R72TT	R72TTCE	R72TT1.3	R85TT1.0
R50TT	R62TT																
	R72TT1.3																
R50TT	R62TT	R72TT															
R72TTCE	R72TT1.3	R85TT1.0															
RG0123EN		Guarnizione da 4-6 mm su f.vetro <i>mm 4-6 glass support weatherstrip</i> E.P.D.M. <table border="1"><tr><td>R50TT</td><td>R62TT</td><td>R72TT</td></tr><tr><td>R72TTCE</td><td>R72TT1.3</td><td>R85TT1.0</td></tr></table>	R50TT	R62TT	R72TT	R72TTCE	R72TT1.3	R85TT1.0	RG0135EN		Guarnizione di precamera. <i>Central weatherstrip.</i> E.P.D.M. <table border="1"><tr><td>R50TT</td><td></td><td>R72TT</td></tr><tr><td>R72TTCE</td><td>R72TT1.3</td><td></td></tr></table>	R50TT		R72TT	R72TTCE	R72TT1.3	
R50TT	R62TT	R72TT															
R72TTCE	R72TT1.3	R85TT1.0															
R50TT		R72TT															
R72TTCE	R72TT1.3																
RG0124EN		Guarnizione su fermavetro da 2,5-3,5 mm <i>mm 2,5-3,5 glass support weatherstrip</i> E.P.D.M. <table border="1"><tr><td>R50TT</td><td>R62TT</td><td>R72TT</td></tr><tr><td>R72TTCE</td><td>R72TT1.3</td><td>R85TT1.0</td></tr></table>	R50TT	R62TT	R72TT	R72TTCE	R72TT1.3	R85TT1.0	RG0139RN		Guarnizione appoggio vetri 1.5 mm <i>Weatherstrip on glass support mm 1,5</i> E.P.D.M. <table border="1"><tr><td>R50TT</td><td>R62TT</td><td>R72TT</td></tr><tr><td>R72TTCE</td><td>R72TT1.3</td><td>R85TT1.0</td></tr></table>	R50TT	R62TT	R72TT	R72TTCE	R72TT1.3	R85TT1.0
R50TT	R62TT	R72TT															
R72TTCE	R72TT1.3	R85TT1.0															
R50TT	R62TT	R72TT															
R72TTCE	R72TT1.3	R85TT1.0															
RG0126EN		Guarnizione di battuta <i>Weatherstrip of rabbet</i> EN = E.P.D.M.	RG0140RN		Guarnizione appoggio vetri da 3 mm <i>mm 3 glass support weatherstrip</i> E.P.D.M. <table border="1"><tr><td>R50TT</td><td>R62TT</td><td>R72TT</td></tr><tr><td>R72TTCE</td><td>R72TT1.3</td><td>R85TT1.0</td></tr></table>	R50TT	R62TT	R72TT	R72TTCE	R72TT1.3	R85TT1.0						
R50TT		R62TT	R72TT														
R72TTCE		R72TT1.3	R85TT1.0														
RG0138RN	RN = PVC coestruso <i>Coextruded P.V.C</i>	RG0143EN		Guarnizione aggiuntiva di precamera <i>Additional central weatherstrip</i> E.P.D.M. <table border="1"><tr><td></td><td></td><td></td></tr><tr><td>R72TTCE</td><td>R72TT1.3</td><td></td></tr></table>				R72TTCE	R72TT1.3								
R72TTCE	R72TT1.3																
RG0155TN	TN = T.P.E. <i>T.P.R</i> <table border="1"><tr><td>R50TT</td><td>R62TT</td><td>R72TT</td></tr><tr><td></td><td>R72TT1.3</td><td>R85TT1.0</td></tr></table>	R50TT	R62TT	R72TT		R72TT1.3	R85TT1.0										
R50TT	R62TT	R72TT															
	R72TT1.3	R85TT1.0															
RG0127EN		Guarnizione su fermavetro spessore 2 mm <i>Weatherstrip on glazing bead shim mm 2</i> E.P.D.M. <table border="1"><tr><td>R50TT</td><td>R62TT</td><td>R72TT</td></tr><tr><td>R72TTCE</td><td>R72TT1.3</td><td>R85TT1.0</td></tr></table>	R50TT	R62TT	R72TT	R72TTCE	R72TT1.3	R85TT1.0	RG0148EN		Guarnizione sotto vetro <i>Weatherstrips under glass</i> E.P.D.M. <table border="1"><tr><td></td><td></td><td></td></tr><tr><td>R72TTCE</td><td>R72TT1.3</td><td></td></tr></table>				R72TTCE	R72TT1.3	
R50TT	R62TT	R72TT															
R72TTCE	R72TT1.3	R85TT1.0															
R72TTCE	R72TT1.3																
RG0128EN		Guarnizione su fermavetro spessore 3 mm <i>Weatherstrip on glazing bead shim mm 3</i> E.P.D.M. <table border="1"><tr><td>R50TT</td><td>R62TT</td><td>R72TT</td></tr><tr><td>R72TTCE</td><td>R72TT1.3</td><td>R85TT1.0</td></tr></table>	R50TT	R62TT	R72TT	R72TTCE	R72TT1.3	R85TT1.0	RG0149EN		Guarnizione su fermavetro spessore 4 mm <i>Weatherstrip on glazing bead shim mm 4</i> E.P.D.M. <table border="1"><tr><td>R50TT</td><td>R62TT</td><td>R72TT</td></tr><tr><td>R72TTCE</td><td>R72TT1.3</td><td>R85TT1.0</td></tr></table>	R50TT	R62TT	R72TT	R72TTCE	R72TT1.3	R85TT1.0
R50TT	R62TT	R72TT															
R72TTCE	R72TT1.3	R85TT1.0															
R50TT	R62TT	R72TT															
R72TTCE	R72TT1.3	R85TT1.0															
RG0129EN		Guarnizione su fermavetro spessore 6 mm <i>Weatherstrip on glazing bead shim mm 6</i> E.P.D.M. <table border="1"><tr><td>R50TT</td><td>R62TT</td><td>R72TT</td></tr><tr><td>R72TTCE</td><td>R72TT1.3</td><td>R85TT1.0</td></tr></table>	R50TT	R62TT	R72TT	R72TTCE	R72TT1.3	R85TT1.0	RG0150EN		Guarnizione su fermavetro spessore 5 mm <i>Weatherstrip on glazing bead shim mm 5</i> E.P.D.M. <table border="1"><tr><td>R50TT</td><td>R62TT</td><td>R72TT</td></tr><tr><td>R72TTCE</td><td>R72TT1.3</td><td>R85TT1.0</td></tr></table>	R50TT	R62TT	R72TT	R72TTCE	R72TT1.3	R85TT1.0
R50TT	R62TT	R72TT															
R72TTCE	R72TT1.3	R85TT1.0															
R50TT	R62TT	R72TT															
R72TTCE	R72TT1.3	R85TT1.0															
RG0131EN		Guarnizione di battuta inserimento a scatto <i>Released insertion weatherstrip of rabbet</i> E.P.D.M. <table border="1"><tr><td>R50TT</td><td>R62TT</td><td>R72TT</td></tr><tr><td></td><td>R72TT1.3</td><td>R85TT1.0</td></tr></table>	R50TT	R62TT	R72TT		R72TT1.3	R85TT1.0	RG0152EN		Guarnizione appoggio esterno vetri da 3 mm <i>mm 3 glass support weatherstrip</i> E.P.D.M. <table border="1"><tr><td>R50TT</td><td>R62TT</td><td>R72TT</td></tr><tr><td>R72TTCE</td><td>R72TT1.3</td><td>R85TT1.0</td></tr></table>	R50TT	R62TT	R72TT	R72TTCE	R72TT1.3	R85TT1.0
R50TT	R62TT	R72TT															
	R72TT1.3	R85TT1.0															
R50TT	R62TT	R72TT															
R72TTCE	R72TT1.3	R85TT1.0															

**GUARNIZIONI
WEATHERSTRIPS**

**ISOLANTE TERMICO
THERMIC INSULATION**

Articolo Item	Immagine Picture	Descrizione Description	Articolo Item	Immagine Picture	Descrizione Description									
RG0154EN		Guarnizione di battuta inserimento a scatto <i>Released insertion weatherstrip of rabbet</i> E.P.D.M.	RA0393WA (*)		Isolante per profilati con tubolare da 28 mm <i>Insulation for profile piping 28 mm</i>									
		<table border="1"><tr><td>R72TTCE</td><td>R72TT1.3</td><td></td></tr></table>	R72TTCE	R72TT1.3				<table border="1"><tr><td>R72TTCE</td><td>R72TT1.3</td><td>R85TT1.0</td></tr></table>	R72TTCE	R72TT1.3	R85TT1.0			
R72TTCE	R72TT1.3													
R72TTCE	R72TT1.3	R85TT1.0												
RG0168EN		Guarnizione isolamento termico telaio-muro <i>Weatherstrip thermal insulation frame-wall</i>	RA0394WA (*)		Isolante per profilati RR72C688, RR72C707 <i>Insulation for sections RR72C688, RR72C707</i>									
		<table border="1"><tr><td>R50TT</td><td>R62TT</td><td>R72TT</td></tr><tr><td>R72TTCE</td><td>R72TT1.3</td><td>R85TT1.0</td></tr></table>	R50TT	R62TT	R72TT	R72TTCE	R72TT1.3	R85TT1.0			<table border="1"><tr><td>R72TTCE</td><td>R72TT1.3</td><td>R85TT1.0</td></tr></table>	R72TTCE	R72TT1.3	R85TT1.0
R50TT	R62TT	R72TT												
R72TTCE	R72TT1.3	R85TT1.0												
R72TTCE	R72TT1.3	R85TT1.0												
RG0169EN		Guarnizione di battuta <i>Weatherstrip of rabbet</i>	RA0395WA (*)		Isolante per profilati con tubolare da 52 mm <i>Insulation for profile piping 52 mm</i>									
		<table border="1"><tr><td></td><td></td><td>R72TT</td></tr><tr><td></td><td>R72TT1.3</td><td></td></tr></table>			R72TT		R72TT1.3				<table border="1"><tr><td>R72TTCE</td><td>R72TT1.3</td><td>R85TT1.0</td></tr></table>	R72TTCE	R72TT1.3	R85TT1.0
		R72TT												
	R72TT1.3													
R72TTCE	R72TT1.3	R85TT1.0												
RG0175EN		Guarnizione di precamera. <i>Central weatherstrip.</i> E.P.D.M	RA0396WA (*)		Isolante per profilati RR72C646, RR72C647 <i>Insulation for sections RR72C646, RR72C647</i>									
		<table border="1"><tr><td>R50TT</td><td></td><td>R72TT</td></tr><tr><td>R72TTCE</td><td>R72TT1.3</td><td></td></tr></table>	R50TT		R72TT	R72TTCE	R72TT1.3				<table border="1"><tr><td>R72TTCE</td><td>R72TT1.3</td><td>R85TT1.0</td></tr></table>	R72TTCE	R72TT1.3	R85TT1.0
R50TT		R72TT												
R72TTCE	R72TT1.3													
R72TTCE	R72TT1.3	R85TT1.0												
RG0314RN		Guarnizione di tenuta su profili 800780 <i>Sealing weatherstrip on profile 800780</i> P.V.C coestruso <i>Coextruded P.V.C</i>	RA0232WA (°)		Isolante adesivo per sottovetro e telaio 10x5 mm <i>Adhesive insulation for frame and underglass 10x5 mm</i>									
		<table border="1"><tr><td>R50TT</td><td>R62TT</td><td>R72TT</td></tr><tr><td>R72TTCE</td><td>R72TT1.3</td><td>R85TT1.0</td></tr></table>	R50TT	R62TT	R72TT	R72TTCE	R72TT1.3	R85TT1.0			<table border="1"><tr><td>R72TTCE</td><td>R72TT1.3</td><td></td></tr></table>	R72TTCE	R72TT1.3	
R50TT	R62TT	R72TT												
R72TTCE	R72TT1.3	R85TT1.0												
R72TTCE	R72TT1.3													
RG0316QN		Guarnizione porta spazzolino <i>Weatherstrip woolpile holder</i> P.V.C rigid <i>Rigid P.V.C</i>	RA0235WA (°)		Isolante adesivo per sottovetro 25x6 mm <i>Adhesive insulation for underglass 25x6 mm</i>									
		<table border="1"><tr><td>R50TT</td><td>R62TT</td><td>R72TT</td></tr><tr><td></td><td>R72TT1.3</td><td>R85TT1.0</td></tr></table>	R50TT	R62TT	R72TT		R72TT1.3	R85TT1.0			<table border="1"><tr><td>R72TTCE</td><td>R72TT1.3</td><td></td></tr></table>	R72TTCE	R72TT1.3	
R50TT	R62TT	R72TT												
	R72TT1.3	R85TT1.0												
R72TTCE	R72TT1.3													
RG0317RN		Guarnizione per collegamento profili <i>Profile connection gasket</i> P.V.C. coestruso <i>Coextruded P.V.C.</i>			(*) = Accessori forniti in barre con lunghezza 1 m (*) = Accessories are supplied bars with lenght of 1 m (°) = Accessori forniti in bobine da 25 m (°) = Accessories are supplied in coils of 25 m									
		<table border="1"><tr><td>R50TT</td><td>R62TT</td><td>R72TT</td></tr><tr><td></td><td>R72TT1.3</td><td>R85TT1.0</td></tr></table>	R50TT	R62TT	R72TT		R72TT1.3	R85TT1.0						
R50TT	R62TT	R72TT												
	R72TT1.3	R85TT1.0												

ANGOLI STAMPATI IN EPDM EPDM MOULDED CORNERS

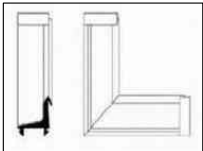
Articolo Item	Immagine Picture	Descrizione Description	Articolo Item	Immagine Picture	Descrizione Description												
RA0228TN		Angolo stampato per guarnizione RG0135EN <i>Moulded corner for weatherstrip RG0135EN</i> TN= Termoplastisca / T.P.R.	RA0239TN		Angolo stampato per guarnizione RG0175EN <i>Moulded corner for weatherstrip RG0175EN</i> TN= Termoplastisca / T.P.R.												
		<table border="1"><tr><td>R50TT</td><td></td><td>R72TT</td></tr><tr><td>R72TTCE</td><td>R72TT1.3</td><td></td></tr></table>	R50TT		R72TT	R72TTCE	R72TT1.3				<table border="1"><tr><td>R50TT</td><td></td><td>R72TT</td></tr><tr><td>R72TTCE</td><td>R72TT1.3</td><td></td></tr></table>	R50TT		R72TT	R72TTCE	R72TT1.3	
R50TT		R72TT															
R72TTCE	R72TT1.3																
R50TT		R72TT															
R72TTCE	R72TT1.3																

DIAGRAMMI E STATICA *STATIC DIAGRAMS*

I grafici di seguito riportati sono stati ottenuti con la seguente formula:
 The graphs below were created using the following formula:

$$J(\text{cm}^4) = \frac{q(\text{Kg}/\text{cm}^2) \times H^4 (\text{cm}) \times A(\text{cm})}{1920 \times E(\text{Kg}/\text{cm}^2) \times f(\text{cm})} \times \left[25 - 40 \times \left(\frac{A}{H} \right)^2 + 16 \times \left(\frac{A}{H} \right)^4 \right]$$

Dove:

Jx = Momento d'inerzia (cm⁴) A = Larghezza anta : 2 (cm)
 q = Carico del vento (Kg/cm²) E = Modulo di elasticità (Kg/cm²)
 H = Altezza anta (cm) f = Freccia (cm)

Essa è riferita al dimensionamento delle ante rispetto all'inerzia del profilato, per cui verificare sempre che il peso delle ante sia compatibile con la portata degli accessori impiegati, cerniere ecc. Inoltre verificare, sempre che la freccia dei profilati sia compatibile con il vetro impiegato.



Were:



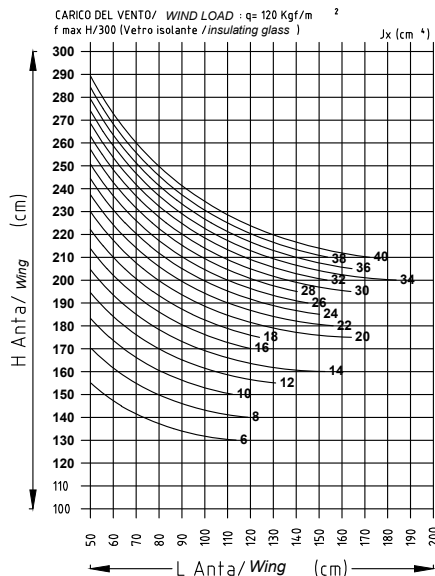
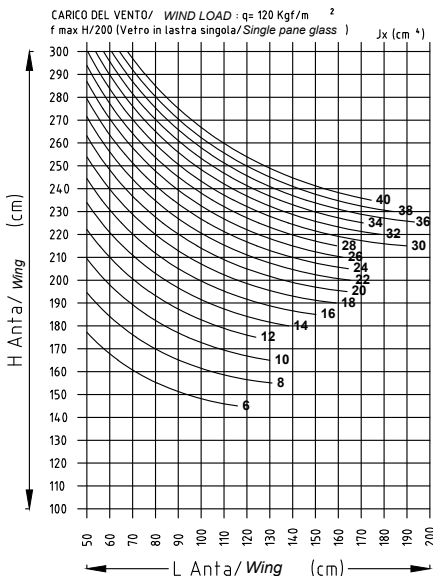
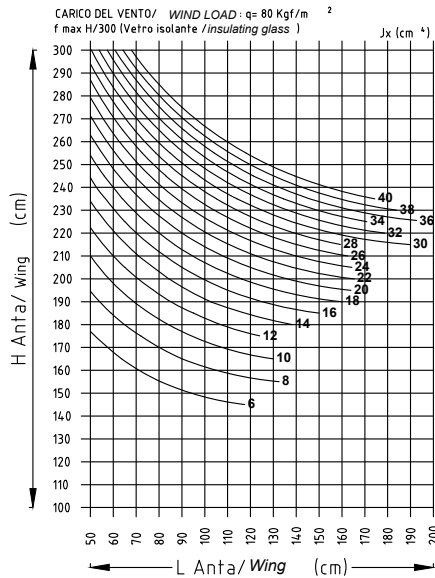
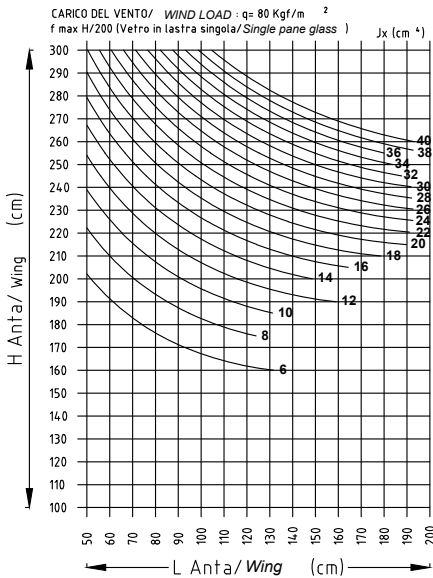
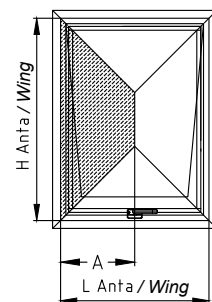
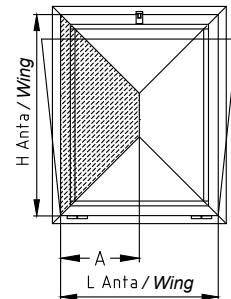
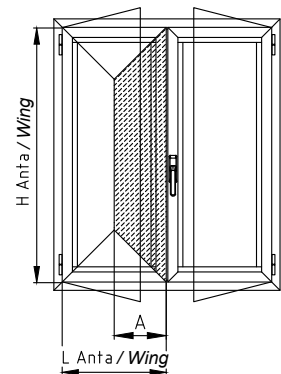
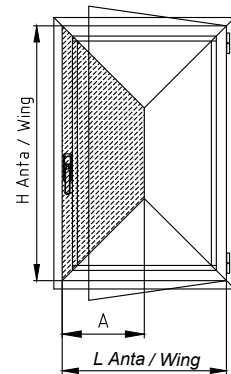







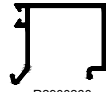

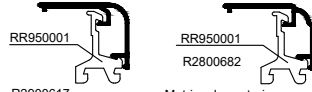
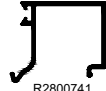



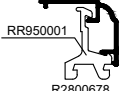

Jx = Moment of inertia (cm⁴) A = Wing/2 width (cm)
 q = Wind load (Kg/cm²) E = Coefficient of elasticity (Kg/cm²)
 H = Wing height (cm) f = Camber (cm)

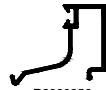
This refers to the size of the wings compared with the section inertia so always make sure the weight of the wings is compatible with the load of accessories hinge etc. used. Also always check that the section camber is suitable for the glass used.



FERMAVETRI
GLASS BEADING

Articolo Item	Guarnizioni esterne External weatherstrips	Sezione Section	Articolo Item	Guarnizioni interne Internal weatherstrips	Sezione Section
RG0152EN	A = 3 mm		RG0124EN	B = 2,5/3,5 mm	
			RG0123EN	C = 4/6 mm	

Spessore vetri Glass thickness	Guarnizioni Weatherstrips	Dimensione fermavetri Glass beading size	Vetro ad infilare Glass to insert			
15 - 17 17 - 18	A+C A+B	35 mm				
20 - 22 22 - 23	A+C A+B	30 mm				
22 - 24 24 - 25	A+C A+B	28 mm				
24 - 26 26 - 27	A+C A+B	26 mm				
27 - 29 30 - 31	A+C A+B	22,5 mm				
28 - 30 30 - 31	A+C A+B	22 mm				
31 - 33 33 - 34	A+C A+B	19 mm				
36 - 38 38 - 39	A+C A+B	14 mm				
39 - 41 41 - 42	A+C A+B	11 mm				
40 - 42 42 - 43	A+C A+B	10 mm				
41 - 43 43 - 44	A+C A+B	9 mm				
45 - 47 47 - 48	A+C A+B	5 mm				
48 - 50 50 - 51	A+C A+B	2 mm				

N.B.: Le combinazioni sopra indicate sono state ottenute considerando le quote teoriche. Si consiglia sempre di verificare le tolleranze per applicare vetri, fermavetri e guarnizioni ottimali.

The above combinations were obtained considering the theoretic heights. It is always best to check tolerances to apply correct glass, glass beadings and weatherstrips.

Sezione Fermavetri Glass Beading Section	Dimensione Size	Soluzione 1 Solution 1
<div style="display: flex; justify-content: space-around;"> <div style="border: 1px solid black; padding: 2px; text-align: center;">F</div> <div style="border: 1px solid black; padding: 2px; text-align: center;">G</div> </div>		
 R2900614 R2900617	30 mm	
 R2800681 R2800682 Matrice da costruire	30 mm	
 R2800677 R2800678	26 mm	
 R2900607 R2600027	22,5 mm	
 R2800303 R2800339	19 mm	
 R2800679 R2800680 Matrice da costruire	18 mm	
 R2800307 R2800313	14 mm	
 R2800661 R2800662 Matrice da costruire	14 mm	

- F = **Fermavetro arr. a scatto**
Radiused glass beading snap
- G = **Fermavetro arr. con accessorio RR950001**
Radiused glass beading with accessoire RR950001
- = **Art. RR950001**
 Per L/H ≤ 1000mm n°3pz
 Per L/H < 1000mm ≤ 1500mm n°4pz
 Per L/H > 1500mm n°5pz

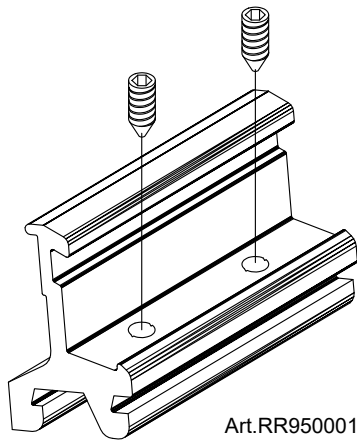

Art. RR950001

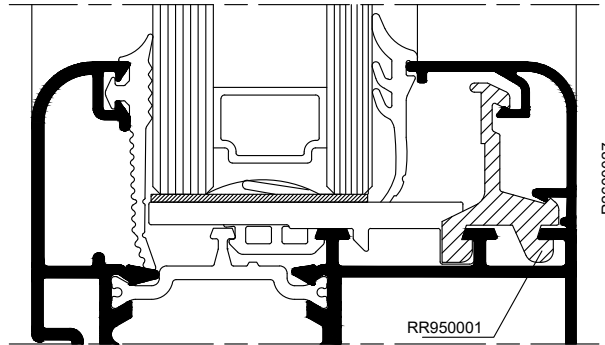

RR950001

SPESSORAMENTO VETRI
GLASS SHIM

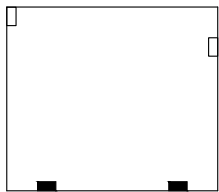

Telaio fisso
Fixed frame

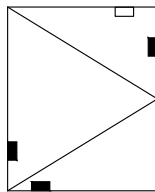

Anta a battente
Casement wing

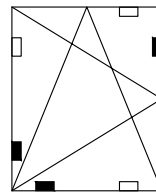

Anta ribalta
Tilt-and-turn window

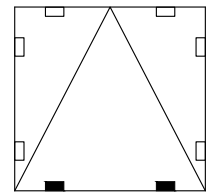

Vasistas
Hopper window

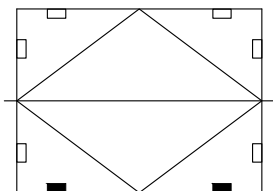

Bilico orizzontale
Horizontal pivoting window

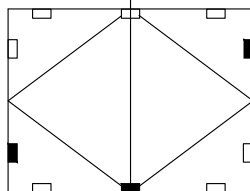

Bilico verticale
Vertical pivoting window

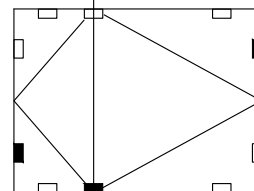



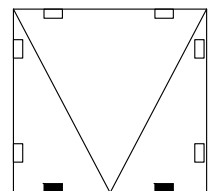



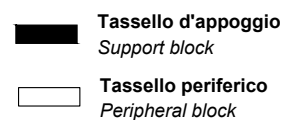







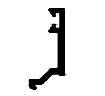

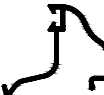
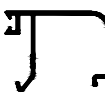



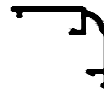

Bilico verticale *Vertical pivoting window*
(asse decentrato) *(Decentralized axis)*

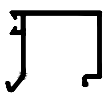

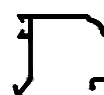
Sporgere
Projecting window

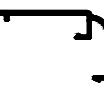
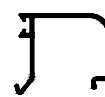
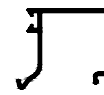
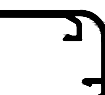

Profilato Section	Sezione Cross section	Peso Weight Kg/ml	Perim. Perim. mm	Sup. in vista Exposed surface m ² /ml	Profilato Section	Sezione Cross section	Peso Weight Kg/ml	Perim. Perim. mm	Sup. in vista Exposed surface m ² /ml
R2600027		0,181	115	0,042	R2800812		0,275	174	0,040
R2800303		0,271	173	0,041	R2800829		0,253	167	0,030
R2800307		0,256	169	0,040	R2800851		0,231	109	0,035
R2800313		0,145	93	0,040	R2800873		0,186	87	0,029
R2800339		0,170	108	0,044	R2800874		0,183	71	0,026
R2800651		0,251	161	0,033	R2800902		0,322	203	0,056
R2800661		0,259	167	0,032	R2900256		0,273	183	0,036
R2800662 Matrice da costruire		0,140	90	0,031	R2900257		0,275	177	0,040
R2800677		0,273	173	0,044	R2900258		0,278	178	0,044
R2800678		0,184	117	0,044	R2900259		0,286	180	0,048
R2800679		0,265	169	0,036	R2900260		0,288	182	0,052
R2800680 Matrice da costruire		0,154	99	0,036	R2900530		0,276	114	0,039
R2800681		0,281	178	0,048	R2900607		0,271	175	0,042
R2800682 Matrice da costruire		0,197	125	0,048	R2900614		0,278	180	0,050
R2800741		0,289	183	0,050	R2900617		0,219	129	0,052
R2800755		0,262	167	0,032					

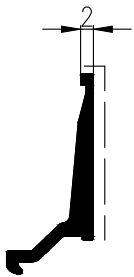

R2800874

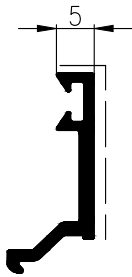

R2800873

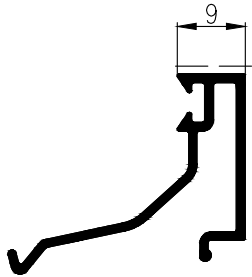

R2800755

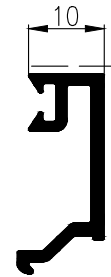

R2800851

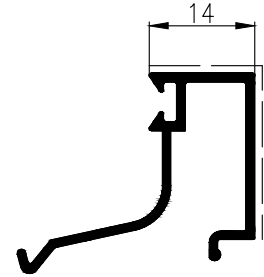

R2900256

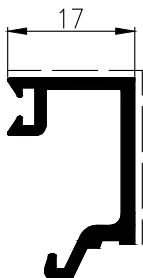

R2900530

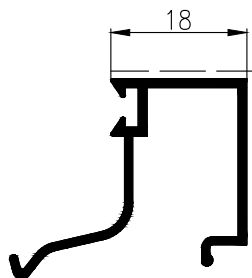

R2900257

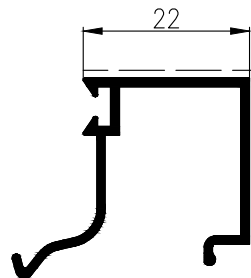

R2900258

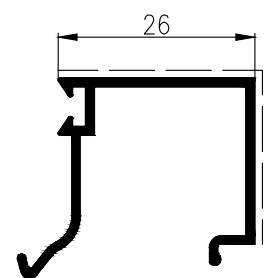

R2900259

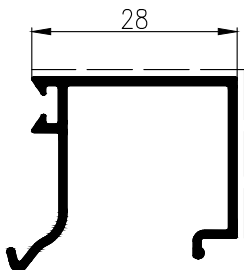

R2800741

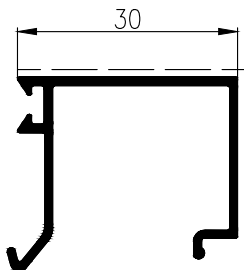

R2900260

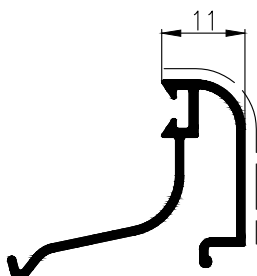

R2800829

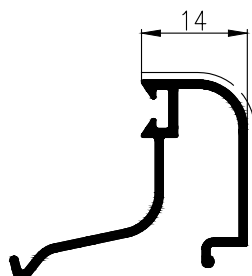

R2800307

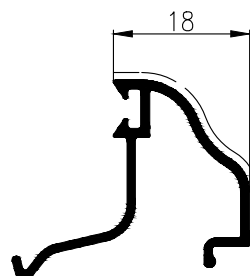

R2800651

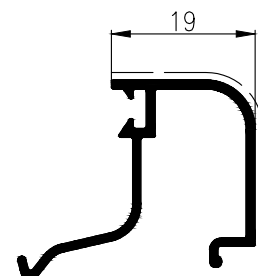

R2800303

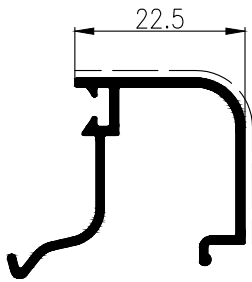

R2900607

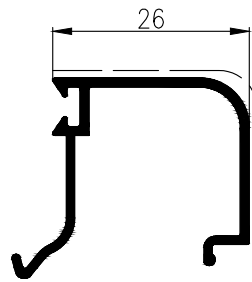

R2800812

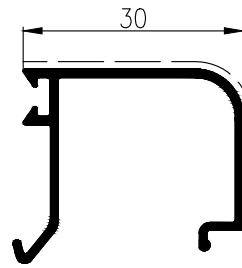

R2900614

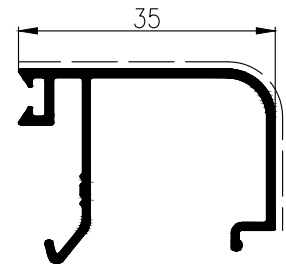

R2800902

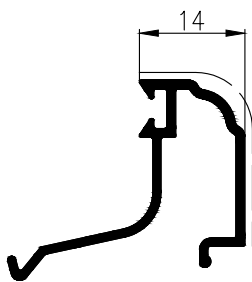

R2800661

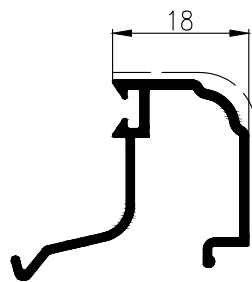

R2800679

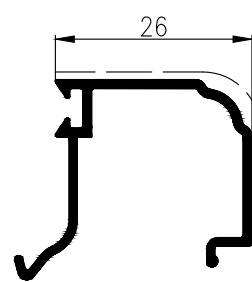

R2800677

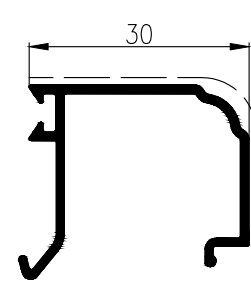

R2800681

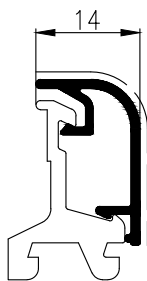

R2800313

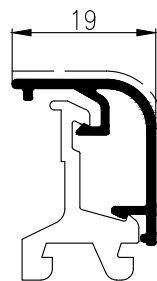

R2800339

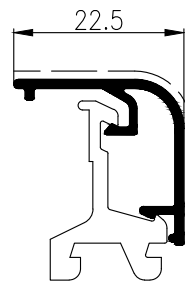

R2600027

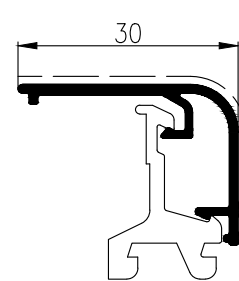

R2900617

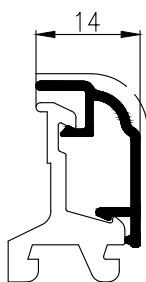

R2800662
Matrice da costruire

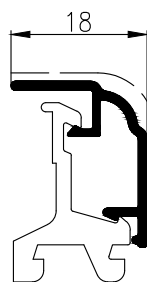

R2800680
Matrice da costruire

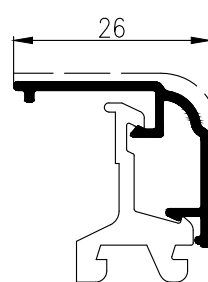



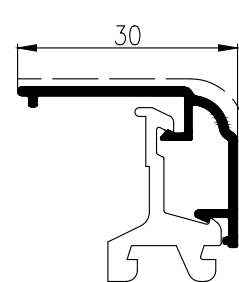





R2800678

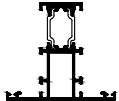

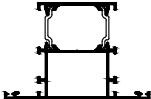
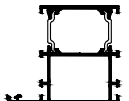
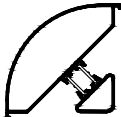
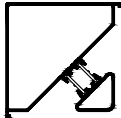
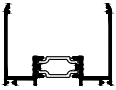

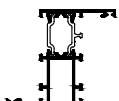
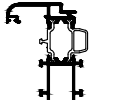
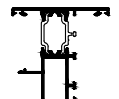

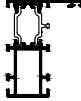
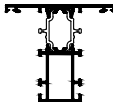
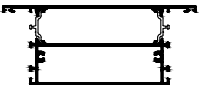
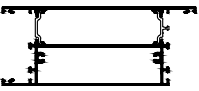
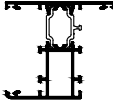
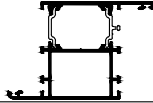
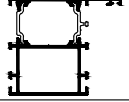
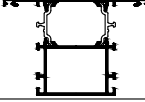
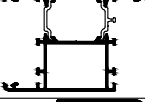
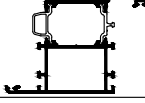
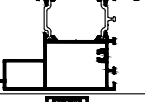

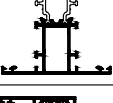
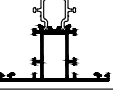
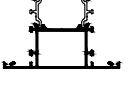
R2800682
Matrice da costruire

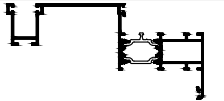
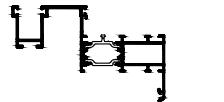
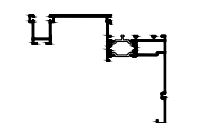
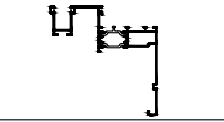
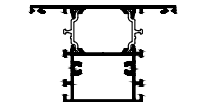
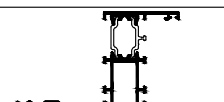
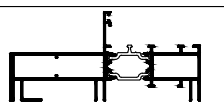
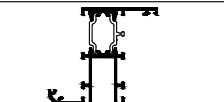
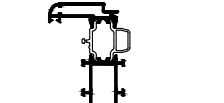
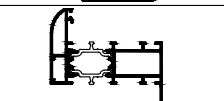
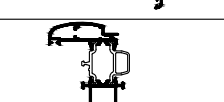
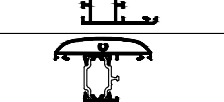
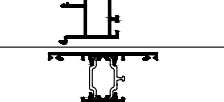
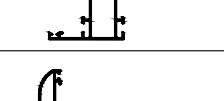
ELENCO PROFILATI
LIST OF SECTIONS

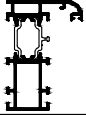
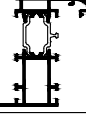
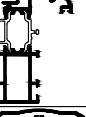
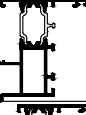
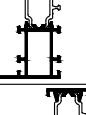
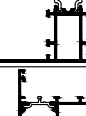

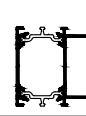
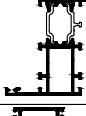
Profilato Section	Comp.ne Composition	Sezione Cross section	Y X — X Y	Peso Weight Kg/m	Perimetro Perimeter mm	Superficie in vista Visible surface mm	Jx cm ⁴	Wx cm ³	Jy cm ⁴	Wy cm ³
R2R72C38	R2800798 RA0320LN RA0320LN R2800613			1,477	452	138	25,14	7,02	9,33	2,58
R2R72C59	R2800538 RA0335LN RA0335LN R2800608			1,201	355	83	20,76	5,82	5,43	1,64
R2R72C60	R2800538 RA0335LN RA0335LN R2800597			1,318	419	110	23,57	6,15	9,05	2,51
R2R72C61	R2800504 RA0335LN RA0335LN R2800597			1,436	482	137	28,95	8,28	12,06	3,14
R2R72C62	R2800540 RA0335LN RA0335LN R2800598			1,618	467	158	31,62	8,63	27,55	5,74
R2R72C89	R2800540 RA0335LN RA0335LN R2800591			1,497	401	129	28,40	8,31	20,00	4,46
RR62C116	R2800610 RA0320LN RA0320LN R2800837			1,651	360	194	23,63	6,07	38,20	7,16
RR62C117	R2800610 RA0320LN RA0320LN R2800838			1,774	387	221	40,31	7,56	40,27	7,55
RR72C128	R2800830 RA0335LN RA0335LN R2800830			1,156	467	105	8,27	2,26	27,61	7,82
RR72C639	R2800617 RA0334LN RA0334LN R2800592			2,389	588	258	104,74	18,24	36,13	7,53
RR72C641	R2800504 RA0335LN RA0334LN R2800585			1,326	490	113	7,53	2,77	19,97	6,18
RR72C642	R2800507 RA0334LN RA0333LN R2800585			1,467	475	114	32,48	8,99	10,53	2,76
RR72C643	R2800587 RA0335LN RA0334LN R2800586			1,349	441	107	25,40	6,51	8,23	2,31



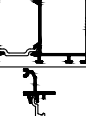

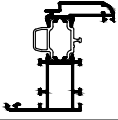
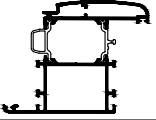
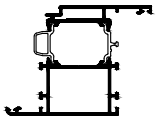
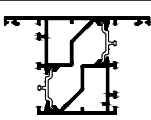
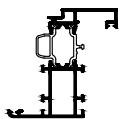
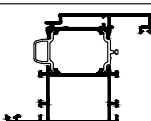
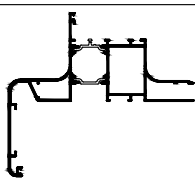
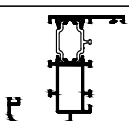
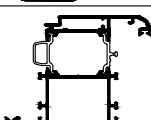
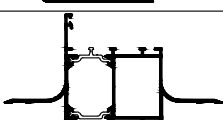
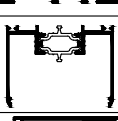
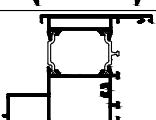
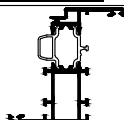
Profilato Section	Comp.ne Composition	Sezione Cross section	Y X—X Y	Peso Weight Kg/m	Perimetro Perimeter mm	Superficie in vista Visible surface mm	Jx cm ⁴	Wx cm ³	Jy cm ⁴	Wy cm ³
RR72C644	R2800504 RA0335LN RA0334LN R2800588			1,214	428	88	16,62	4,76	4,90	2,43
RR72C645	R2800508 RA0334LN RA0334LN R2800588			1,342	440	110	23,84	6,29	9,08	2,52
RR72C646	R2800511 RA0334LN RA0334LN R2800589			2,633	611	282	53,21	15,31	174,15	22,02
RR72C647	R2800511 RA0335LN RA0334LN R2800590			2,739	673	309	57,82	17,37	194,62	23,69
RR72C648	R2800508 RA0334LN RA0335LN R2800585			1,442	499	136	28,95	8,33	11,88	3,10
RR72C649	R2800514 RA0335LN RA0334LN R2800591			1,626	483	156	32,66	10,06	27,22	5,65
RR72C650	R2800514 RA0335LN RA0334LN R2800592			1,513	422	131	28,35	8,09	20,37	4,57
RR72C651	R2800516 RA0334LN RA0334LN R2800592			1,645	488	158	31,38	8,43	27,67	5,76
RR72C652	R2800516 RA0335LN RA0334LN R2800591			1,746	547	183	36,30	10,46	33,51	6,61
RR72C653	R2800517 RA0333LN RA0334LN R2800591			1,868	541	161	44,24	11,73	31,18	6,23
RR72C654	R2800514 RA0335LN RA0334LN R2800593			1,832	440	153	34,03	10,15	36,89	7,40
RR72C659	R2800538 RA0334LN RA0334LN R2800608			1,227	429	91	16,39	4,56	5,35	1,94
RR72C660	R2800538 RA0334LN RA0334LN R2800597			1,344	493	119	18,59	4,81	9,11	2,82
RR72C661	R2800504 RA0334LN RA0334LN R2800597			1,462	556	142	22,96	6,52	11,47	3,43
RR72C662	R2800540 RA0335LN RA0335LN R2800598			1,646	639	166	25,15	6,85	27,77	6,49

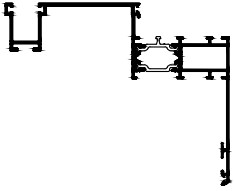
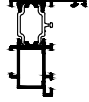
Profilato Section	Comp.ne Composition	Sezione Cross section	Peso Weight Kg/m	Perimetro Perimeter mm	Superficie in vista Visible surface mm	Jx cm ⁴	Wx cm ³	Jy cm ⁴	Wy cm ³
RR72C664	R2800547 RA0335LN RA0334LN R2800585		2,072	803	126	13,34	4,05	133,45	16,22
RR72C665	R2800548 RA0335LN RA0334LN R2800585		1,921	739	94	11,76	3,74	72,43	11,65
RR72C666	R2800547 RA0335LN RA0334LN R2800705		2,254	882	186	40,57	7,60	156,60	17,71
RR72C667	R2800548 RA0335LN RA0334LN R2800705		2,104	817	154	38,99	7,30	87,93	12,99
RR72C669	R2800516 RA0334LN RA0334LN R2800603		1,803	488	158	32,58	9,10	29,40	6,12
RR72C670	R2800504 RA0335LN RA0334LN R2800604		1,517	527	143	30,82	8,47	28,26	4,47
RR72C671	R2800575 RA0335LN RA0334LN R2800605		2,206	653	162	11,25	3,00	128,42	19,88
RR72C672	R2800504 RA0335LN RA0334LN R2800607		1,358	444	114	25,81	7,88	10,04	2,74
RR72C673	R2800618 RA0334LN RA0333LN R2800585		1,485	432	114	32,41	9,00	11,11	2,89
RR72C674	R2800585 RA0334LN RA0333LN R2800620		1,639	623	113	10,14	3,98	31,06	7,79
RR72C675	R2800621 RA0334LN RA0333LN R2800585		1,539	430	116	34,76	9,30	11,42	2,94
RR72C676	R2800622 RA0335LN RA0334LN R2800586		1,677	445	114	37,21	8,00	11,89	3,42
RR72C677	R2800508 RA0335LN RA0334LN R2800608		1,477	500	137	29,17	8,43	12,08	3,14
RR72C678	R2800588 RA0334LN RA0334LN R2800620		1,527	567	88	7,51	3,35	25,76	5,98

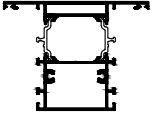
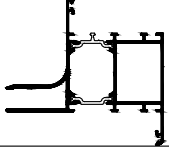
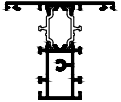
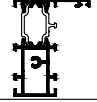
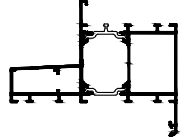
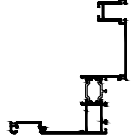
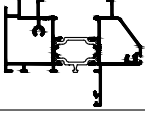
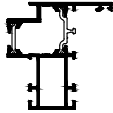
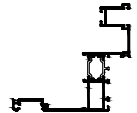

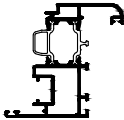
Profilato Section	Comp.ne Composition	Sezione Cross section	Y X—X Y	Peso Weight Kg/m	Perimetro Perimeter mm	Superficie in vista Visible surface mm	Jx cm ⁴	Wx cm ³	Jy cm ⁴	Wy cm ³
RR72C681	R2800648 RA0335LN RA0334LN R2800588			1,429	429	88	29,83	7,20	7,61	2,37
RR72C682	R2800648 RA0335LN RA0334LN R2800585			1,541	491	114	35,91	9,41	11,28	3,01
RR72C683	R2800649 RA0333LN RA0334LN R2800585			1,475	465	115	32,85	9,11	10,64	2,81
RR72C684	R2800650 RA0335LN RA0334LN R2800586			1,690	450	117	37,62	8,03	12,50	3,60
RR72C686	R2800504 RA0335LN RA0334LN R2800701			1,412	475	127	27,70	8,15	15,43	3,02
RR72C687	R2800504 RA0335LN RA0334LN R2800659			1,572	553	156	32,26	8,61	40,81	5,59
RR72C688	R2800690 RA0335LN RA0334LN R2800689			2,797	892	267	78,00	10,27	210,86	23,19
RR72C689	R2800540 RA0334LN RA0334LN R2800591			1,524	573	138	19,93	5,21	22,51	6,55
RR72C690	R2800504 RA0335LN RA0334LN R2800608			1,331	437	110	25,32	7,86	9,07	2,52
RR72C691	R2800548 RA0335LN RA0334LN R2800701			2,001	778	112	17,20	4,51	78,59	12,20
RR72C692	R2800548 RA0335LN RA0334LN R2800659			2,170	802	141	61,15	7,36	112,83	16,43
RR72C694	R2800514 RA0334LN RA0335LN R2800727			2,001	733	154	23,76	6,92	53,89	8,85
RR72C696	R2800730 RA0334LN R2800731			0,889	361	16	18,75	4,25	0,58	0,40

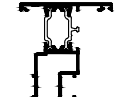
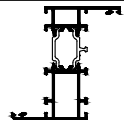
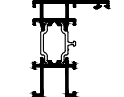
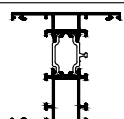
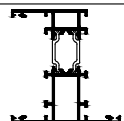
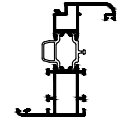
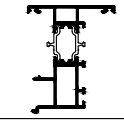
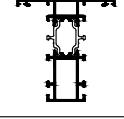
Profilato Section	Comp.ne Composition	Sezione Cross section	Y X — X Y	Peso Weight Kg/m	Perimetro Perimeter mm	Superficie in vista Visible surface mm	Jx cm ⁴	Wx cm ³	Jy cm ⁴	Wy cm ³
RR72C698	R2800722 RA0333LN RA0334LN R2800585			1,483	432	115	32,24	8,94	11,00	2,87
RR72C700	R2800770 RA0333LN RA0334LN R2800591			1,916	772	163	36,65	9,54	28,55	7,35
RR72C703	R2800788 RA0333LN RA0334LN R2800591			1,861	497	157	44,65	11,80	27,88	5,70
RR72C704	R2800797 RA0334LN RA0334LN R2800796			1,955	513	158	36,36	10,08	28,39	5,92
RR72C705	R2800802 RA0333LN RA0334LN R2800585			1,477	465	119	33,12	9,14	11,05	2,90
RR72C706	R2800805 RA0333LN RA0334LN R2800591			1,876	512	161	44,65	11,76	31,86	6,33
RR72C707	R2800806 RA0335LN RA0334LN R2800689			2,943	890	261	82,85	11,00	216,42	23,30
RR72C708	R2800504 RA0335LN RA0334LN R2800825			1,469	556	136	25,73	7,03	11,48	3,88
RR72C709	R2800827 RA0333LN RA0334LN R2800591			1,878	545	161	44,58	11,77	31,53	6,28
RR72C710	R2800828 RA0335LN RA0334LN R2800727			2,465	741	166	30,78	5,85	122,13	16,73
RR72C711	R2800830 RA0334LN RA0334LN R2800830			1,182	388	111	8,28	2,26	22,06	6,25
RR72C712	R2800832 RA0335LN RA0334LN R2800593			2,051	715	160	39,13	10,80	36,35	9,05
RR72C713	R2800831 RA0333LN RA0334LN R2800585			1,425	443	109	31,88	8,64	8,87	2,42

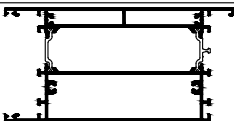
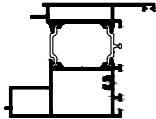
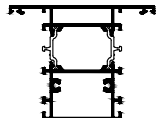
Profilato Section	Comp.ne Composition	Sezione Cross section	Y X Y	Peso Weight Kg/m	Perimetro Perimeter mm	Superficie in vista Visible surface mm	Jx cm ⁴	Wx cm ³	Jy cm ⁴	Wy cm ³
RR72C714	R2800547 RA0335LN RA0334LN R2800659			2,322	920	174	39,33	7,31	160,71	17,90
RR72C715	R2800504 RA0335LN RA0334LN R2800835			1,159	352	61	17,98	4,84	4,97	1,55
RR72C718	R5600051 RA0334LN RA0334LN R5600051			1,583	478	201	0,16	0,54	43,42	8,09
RR72C719	R2800789 RA0334LN RA0334LN R2800603			2,015	783	157	31,53	8,73	36,42	8,94
RR72C720	R2800828 RA0335LN RA0334LN R2800591			2,092	644	172	32,00	6,19	67,81	11,47
RR72C721	R2800508 RA0334LN RA0334LN R2800852			1,424	465	112	24,55	6,66	9,11	2,52
RR72C722	R2800504 RA0335LN RA0334LN R2800852			1,296	373	85	21,31	6,24	5,47	1,65
RR72C723	R2800859 RA0335LN RA0334LN R2800591			2,184	903	200	31,72	8,32	69,38	11,26
RR72C724	R2800547 RA0335LN RA0334LN R2800959			2,525	910	0,184	210,37	22,70	107,67	12,29
RR72C725	R2800875 RA0335LN RA0334LN R2800876			1,870	520	102	49,36	10,40	16,21	4,00
RR72C726	R2800860 RA0320LN RA0334LN R2800861			1,364	384	83	21,68	5,94	9,76	2,62
RR72C727	R2800548 RA0335LN RA0334LN R2800959			2,378	846	0,152	118,28	16,67	98,58	11,61

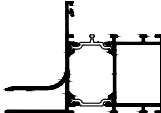
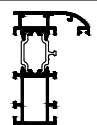
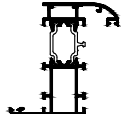
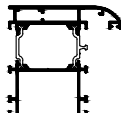
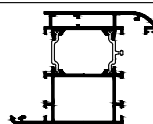
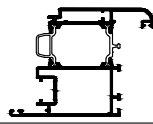
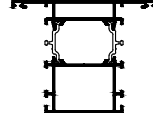
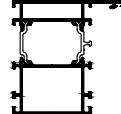
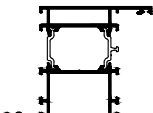
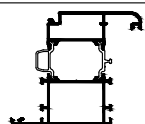
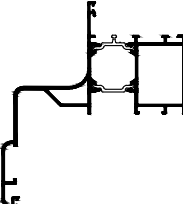
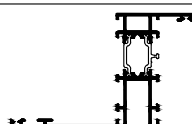

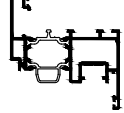
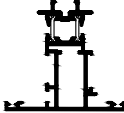

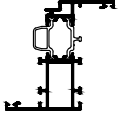
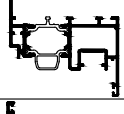
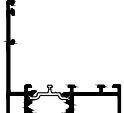
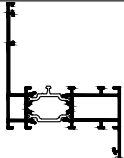
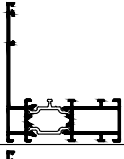
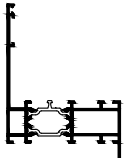
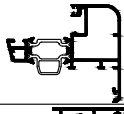
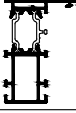
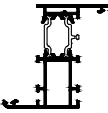

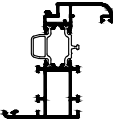
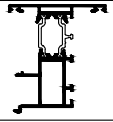
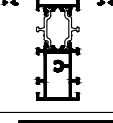
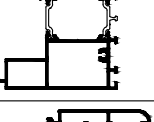
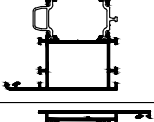
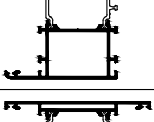
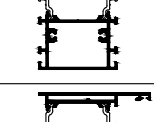
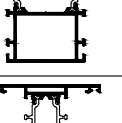
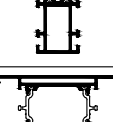
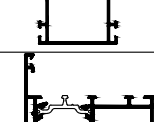
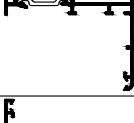
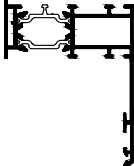

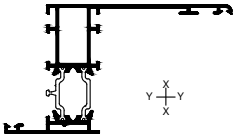
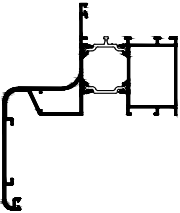
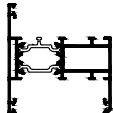
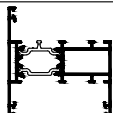
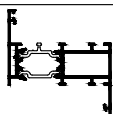
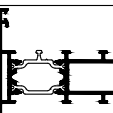
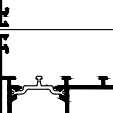
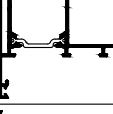
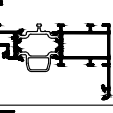
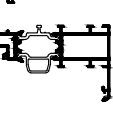
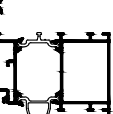













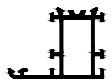

Profilato Section	Comp.ne Composition	Sezione Cross section	Y X	Peso Weight Kg/m	Perimetro Perimeter mm	Superficie in vista Visible surface mm	Jx cm ⁴	Wx cm ³	Jy cm ⁴	Wy cm ³
RR72C728	R2800907 RA0333LN RA0334LN R2800909			1,588	504	123	35,01	9,53	12,47	3,27
RR72C729	R2800871 RA0335LN RA0334LN R2800910			1,306	452	102	18,38	5,05	7,19	3,08
RR72C730	R2800912 RA0335LN RA0334LN R2800585			1,492	481	111	37,49	9,83	9,44	2,61
RR72C731	R2800912 RA0335LN RA0334LN R2800588			1,380	419	85	31,41	7,57	6,08	1,82
RR72C732	R2800913 RA0335LN RA0334LN R2800608			1,612	548	130	42,85	10,48	12,77	3,35
RR72C735	R2800912 RA0335LN RA0335LN R2800597			1,602	653	141	34,35	8,56	12,31	3,62
RR72C736	R2800915 RA0335LN RA0335LN R2800585			1,570	496	104	45,45	10,84	10,65	2,84
RR72C737	R2800916 RA0334LN RA0334LN R2800586			1,489	471	109	36,91	8,27	8,63	2,44
RR72C738	R2800913 RA0334LN RA0334LN R2800588			1,507	518	103	35,52	8,01	9,74	2,71
RR72C739	R2800688 RA0334LN RA0334LN R2800589			3,229	675	282	84,49	19,54	204,93	25,94
RR72C740	R2800688 RA0335LN RA0334LN R2800590			3,335	722	309	90,93	22,00	219,08	26,84
RR72C741	R2800778 RA0335LN RA0334LN R2800593			2,171	833	174	44,27	11,62	39,09	9,26
RR72C742	R2800922 RA0334LN RA0334LN R2800603			2,051	820	157	39,34	9,40	32,60	8,95

Profilato Section	Comp.ne Composition	Sezione Cross section	Y X Y	Peso Weight Kg/m	Perimetro Perimeter mm	Superficie in vista Visible surface mm	Jx cm ⁴	Wx cm ³	Jy cm ⁴	Wy cm ³
RR72C743	R2800828 RA0335LN RA0334LN R2800592			1,979	582	147	26,59	5,36	59,66	10,56
RR72C744	R2800917 RA0335LN RA0334LN R2800588			1,476	540	88	25,49	5,98	6,95	3,12
RR72C745	R2800917 RA0335LN RA0334LN R2800585			1,587	497	119	38,40	9,74	11,18	2,99
RR72C746	R2800918 RA0335LN RA0334LN R2800592			1,889	742	136	35,02	8,10	25,98	7,85
RR72C747	R2800918 RA0335LN RA0334LN R2800591			2,002	804	161	40,44	9,95	31,54	8,31
RR72C748	R2800919 RA0333LN RA0334LN R2800921			1,964	546	164	46,11	12,45	32,33	6,68
RR72C749	R2800922 RA0334LN RA0334LN R2800592			1,872	562	154	46,43	10,60	30,39	6,33
RR72C750	R2800923 RA0335LN RA0334LN R2800592			1,743	468	127	42,33	10,17	23,22	5,14
RR72C751	R2800923 RA0335LN RA0334LN R2800591			1,858	781	157	38,82	9,98	28,37	7,53
RR72C752	R2800924 RA0333LN RA0334LN R2800591			1,960	545	151	59,24	14,08	32,40	6,52
RR72C753	R2800690 RA0335LN RA0334LN R2800925			2,424	720	248	76,52	10,00	129,00	20,50
RR72C754	R2800912 RA0335LN RA0334LN R2800659			1,738	588	158	48,00	11,23	42,11	5,68

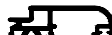



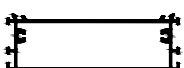







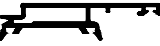



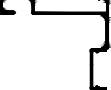

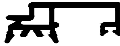
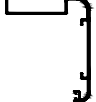
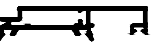
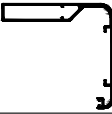

Profilato Section	Comp.ne Composition	Sezione Cross section	Y X Y	Peso Weight Kg/m	Perimetro Perimeter mm	Superficie in vista Visible surface mm	Jx cm ⁴	Wx cm ³	Jy cm ⁴	Wy cm ³
RR72C755	R2800941 RA0334LN RA0333LN R2800909			1,607	614	123	10,44	3,81	28,55	7,82
RR72C756	R2800943 RA0318LN RA0318LN R2800942			1,380	392	75	20,33	5,74	7,94	2,38
RR72C757	R2800944 RA0335LN RA0335LN R2800944			1,512	442	210	12,52	7,16	43,60	8,07
RR72C758	R2800831 RA0334LN RA0333LN R2800608			1,431	533	112	25,59	6,88	7,53	2,97
RR72C761	R2800946 RA0334LN RA0333LN R2800909			1,564	594	115	9,04	3,42	27,91	7,49
RR72C767	R2800971 RA0335LN RA0334LN R2800588			1,565	592	117	30,13	6,58	18,83	4,65
RR72C768	R2800971 RA0335LN RA0334LN R2800585			1,677	669	142	36,14	8,52	21,45	5,81
RR72C769	R2800969 RA0335LN RA0334LN R2800588			1,606	624	125	31,08	6,67	24,30	5,31
RR72C770	R2800969 RA0335LN RA0334LN R2800585			1,719	686	150	37,33	8,62	26,92	6,48
RR72C771	R2800972 RA0335LN RA0333LN R2800973			1,406	526	123	20,35	4,37	10,76	2,99
RR72C775	R2800974 RA0335LN RA0334LN R2800588			1,275	376	83	19,55	5,23	4,94	2,44
RR72C776	R2800974 RA0335LN RA0334LN R2800585			1,387	441	108	23,43	6,88	7,56	2,80

Profilato Section	Comp.ne Composition	Sezione Cross section	Y X Y	Peso Weight Kg/m	Perimetro Perimeter mm	Superficie in vista Visible surface mm	Jx cm ⁴	Wx cm ³	Jy cm ⁴	Wy cm ³
RR72C777	R2800975 RA0333LN RA0334LN R2800585			1,512	493	115	29,53	7,71	8,43	3,37
RR72C778	R2800976 RA0335LN RA0334LN R2800586			1,425	452	111	23,94	5,76	8,35	2,96
RR72C779	R2800991 RA0334LN RA0334LN R2800852			1,505	470	110	23,26	5,90	9,58	3,48
RR72C780	R2800989 RA0335LN RA0334LN R2800593			1,996	449	154	34,25	10,06	35,89	8,89
RR72C781	R2800987 RA0333LN RA0334LN R2800591			1,915	532	165	39,63	10,06	28,32	7,48
RR72C782	R2800988 RA0335LN RA0334LN R2800591			1,762	499	157	31,75	8,80	25,83	6,55
RR72C783	R2800990 RA0334LN RA0334LN R2800603			1,979	568	158	32,05	8,21	31,36	8,69
RR72C784	R2800988 RA0335LN RA0334LN R2800592			1,650	424	131	27,56	7,18	20,28	6,49
RR72C785	R2800991 RA0334LN RA0334LN R2800588			1,421	457	110	22,51	5,55	9,5	3,48
RR72C786	R2800990 RA0334LN RA0334LN R2800592			1,650	505	158	30,45	7,47	29,47	7,96
RR72C787	R2800974 RA0334LN RA0335LN R2800701			1,467	593	127	25,8	7,18	13	3,56
RR72C788	R2800974 RA0334LN RA0335LN R2800604			1,581	476	136	36,59	10,61	12,15	4,21

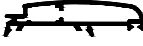
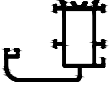
Profilato Section	Comp.ne Composition	Sezione Cross section	Peso Weight Kg/m	Perimetro Perimeter mm	Superficie in vista Visible surface mm	Jx cm ⁴	Wx cm ³	Jy cm ⁴	Wy cm ³
RR72C789	R2800974 RA0334LN RA0335LN R2800659		1,638	676	135	13,03	5,44	135,88	23,99
RR72C790	R2800806 RA0335LN RA0334LN R2800925		2,572	960	243	72,49	12,71	104,59	16,21
RR72C791	R2800991 RA0335LN RA0334LN R2800585		1,520	556	135	27,14	7,28	12,18	3,54
RR72C792	R2800991 RA0335LN RA0334LN R2800608		1,525	558	136	12,36	3,60	27,34	7,36
RR72C793	R2800974 RA0335LN RA0334LN R2800608		1,392	492	109	7,74	2,86	23,59	6,92
RR72C796	R2800991 RA0334LN RA0335LN R2800588		1,408	565	110	22,51	5,55	9,55	3,48
RR72C797	R2800990 RA0334LN RA0335LN R2800591		1,906	818	183	35,24	9,22	35,03	7,65
RR72C798	R2800997 RA0334LN RA0333LN R2800585		1,478	450	110	29,20	7,52	7,50	3,06
MATRICE DA COSTRUIRE									
RR72C799	R2800998 RA0334LN RA0333LN R2800585		1,525	472	118	30,12	7,90	8,78	3,48
MATRICE DA COSTRUIRE									
RR72C800	R2800999 RA0334LN RA0333LN R2800591		1,878	498	159	39,33	10,09	26,23	7,05
MATRICE DA COSTRUIRE									
RR72C801	R2801000 RA0334LN RA0333LN R2800591		1,929	523	167	40,18	10,12	29,04	7,63
MATRICE DA COSTRUIRE									







Profilato Section	Sezione Cross section	Peso Weight Kg/m	Perimetro Perimeter mm	Superficie in vista Visible surface mm	Profilato Section	Sezione Cross section	Peso Weight Kg/m	Perimetro Perimeter mm	Superficie in vista Visible surface mm
R1F14039		0,411	103	0,0	R2800516		0,623	285	106
R1F14041		0,633	199	0,0	R2800517		0,714	239	84
R1F14042		0,141	77	0,0	R2800538		0,272	108	28
R2100009		0,234	82	29	R2800540		0,389	157	52
R2100342		0,143	64	25	R2800547		1,135	485	72
R2201035		0,268	126	0,047	R2800548		0,988	420	40
R2600040		0,900	333	57	R2800575		1,315	416	125
R2800129		0,324	182	74	R2800581		0,314	163	15
R2800291		0,629	231	80	R2800585		0,758	284	54
R2800504		0,390	172	55	R2800586		0,710	247	34
R2800507		0,497	193	60	R2800587		0,461	213	73
R2800508		0,506	236	82	R2800588		0,645	312	28
R2800511		0,924	409	168	R2800589		1,519	395	114
R2800514		0,506	221	79					



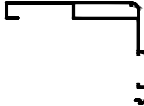
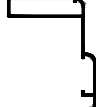

Profilato Section	Sezione Cross section	Peso Weight Kg/m	Perimetro Perimeter mm	Superficie in vista Visible surface mm	Profilato Section	Sezione Cross section	Peso Weight Kg/m	Perimetro Perimeter mm	Superficie in vista Visible surface mm
R2800590		1,637	459	141	R2800618		0,515	163	60
R2800591		0,941	471	77	R2800621		0,569	162	62
R2800592		0,829	271	52	R2800622		0,786	219	80
R2800593		1,148	285	74	R2800648		0,602	229	60
R2800597		0,880	350	82	R2800649		0,505	197	61
R2800598		1,063	399	106	R2800650		0,802	222	83
R2800603		0,987	271	52	R2800659		1,007	401	101
R2800604		0,949	375	88	R2800688		1,520	458	168
R2800605		0,713	258	37	R2800689		1,188	423	71
R2800607		0,790	292	59	R2800690		1,431	531	196
R2800608		0,763	285	55	R2800701		0,836	323	71
R2800610		0,450	120	56	R2800705		0,940	366	94
R2800613		0,911	363	74	R2800722		0,513	164	61
R2800617		1,370	381	206	R2800727		1,315	431	71

Profilato Section	Sezione Cross section	Peso Weight Kg/m	Perimetro Perimeter mm	Superficie in vista Visible surface mm	Profilato Section	Sezione Cross section	Peso Weight Kg/m	Perimetro Perimeter mm	Superficie in vista Visible surface mm
R2800728		0,297	122	42	R2800780		0,432	216	27
R2800729		0,383	159	58	R2800788		0,707	229	80
R2800730		0,297	131	0,0	R2800789		0,818	300	102
R2800731		0,497	197	16	R2800796		0,769	235	52
R2800737		0,980	333	105	R2800797		0,996	362	106
R2800738		0,170	92	27	R2800798		0,460	130	64
R2800759		1,370	469	188	R2800802		0,507	197	65
R2800760		1,043	354	146	R2800805		0,722	245	84
R2800761		1,193	389	165	R2800806		1,577	518	190
R2800762		1,542	540	222	R2800822		0,228	128	62
R2800770		0,761	210	87	R2800825		0,899	349	65
R2800771		0,294	138	56	R2800827		0,724	246	84
R2800772		1,058	426	140	R2800828		0,972	383	95
R2800778		0,810	102	87	R2800830		0,495	221	54

Profilato Section	Sezione Cross section	Peso Weight Kg/m	Perimetro Perimeter mm	Superficie in vista Visible surface mm	Profilato Section	Sezione Cross section	Peso Weight Kg/m	Perimetro Perimeter mm	Superficie in vista Visible surface mm
R2800831		0,455	175	55	R2800909		0,853	299	57
R2800832		0,719	236	85	R2800910		0,676	194	29
R2800835		0,591	201	6	R2800912		0,556	218	57
R2800837		1,095	278	140	R2800913		0,671	282	75
R2800838		1,218	304	160	R2800915		0,600	215	50
R2800839		0,498	188	80	R2800916		0,589	242	75
R2800852		0,728	222	30	R2800917		0,651	234	65
R2800859		1,063	356	110	R2800918		0,881	283	88
R2800860		0,523	222	55	R2800919		0,731	239	86
R2800861		0,693	248	28	R2800921		1,021	341	78
R2800871		0,450	202	75	R2800922		0,853	331	102
R2800875		0,800	269	59	R2800923		0,736	267	75
R2800876		0,892	272	43	R2800924		0,806	263	74
R2800907		0,523	197	66	R2800925		0,815	259	52

Profilato Section	Sezione Cross section	Peso Weight Kg/m	Perimetro Perimeter mm	Superficie in vista Visible surface mm	Profilato Section	Sezione Cross section	Peso Weight Kg/m	Perimetro Perimeter mm	Superficie in vista Visible surface mm
R2800941		0,542	206	67	R2800975		0,542	251	63
R2800942		0,964	323	75	R2800976		0,536	266	74
R2800943		0,328	128	0,0	R2800986		0,469	229	93
R2800944		0,673	267	100	R2800987		0,760	248	88
R2800946		0,498	180	48	R2800988		0,642	216	79
R2800952		1,133	506	228	R2800989		0,666	221	79
R2800953		1,314	566	190	R2800990		0,785	389	106
R2800956		0,268	126	47	R2800991		0,584	293	82
R2800959		1,211	438	88	R2800997		0,508	235	57
					MATRICE DA COSTRUIRE				
R2800969		0,782	302	97	R2800998		0,555	257	65
					MATRICE DA COSTRUIRE				
R2800971		0,741	285	89	R2800999		0,724	342	81
					MATRICE DA COSTRUIRE				
R2800972		0,286	99	26	R2801000		0,774	367	89
					MATRICE DA COSTRUIRE				
R2800973		0,920	310	97	R2900162		0,370	202	70
R2800974		0,451	221	55	R2900221		0,167	57	15

Profilato Section	Sezione Cross section	Peso Weight Kg/m	Perimetro Perimeter mm	Superficie in vista Visible surface mm	Profilato Section	Sezione Cross section	Peso Weight Kg/m	Perimetro Perimeter mm	Superficie in vista Visible surface mm
R2900297		0,996	533	185					
R2900316		0,213	133	68					
R2900319		0,413	138	0,0					
R2900390		0,286	104	30					
R2900600		1,102	441	186					
R2900601		0,820	302	136					
R2900602		0,980	381	156					
R5600051		0,694	271	100					

Codice Code	Sezione Cross section	Peso Weight Kg/m
RA0318LN		0,043
RA0320LN		0,052
RA0333LN		0,117
RA0334LN		0,096
RA0335LN		0,083

Scala 1:1
Scale 1:1

RA0318LN

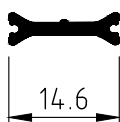

RA0320LN

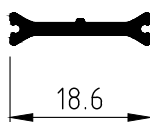

RA0333LN

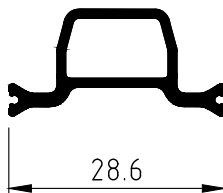

RA0334LN

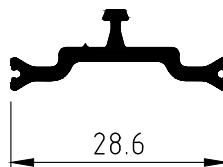

RA0335LN



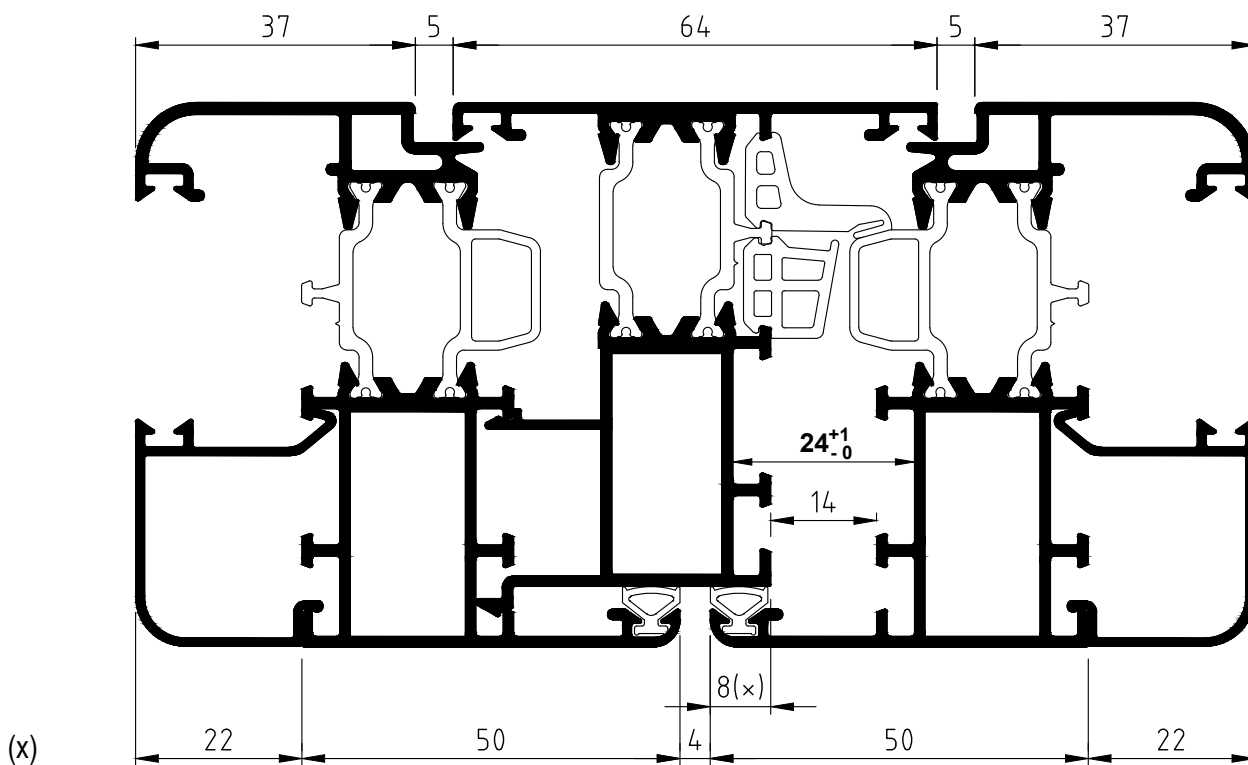
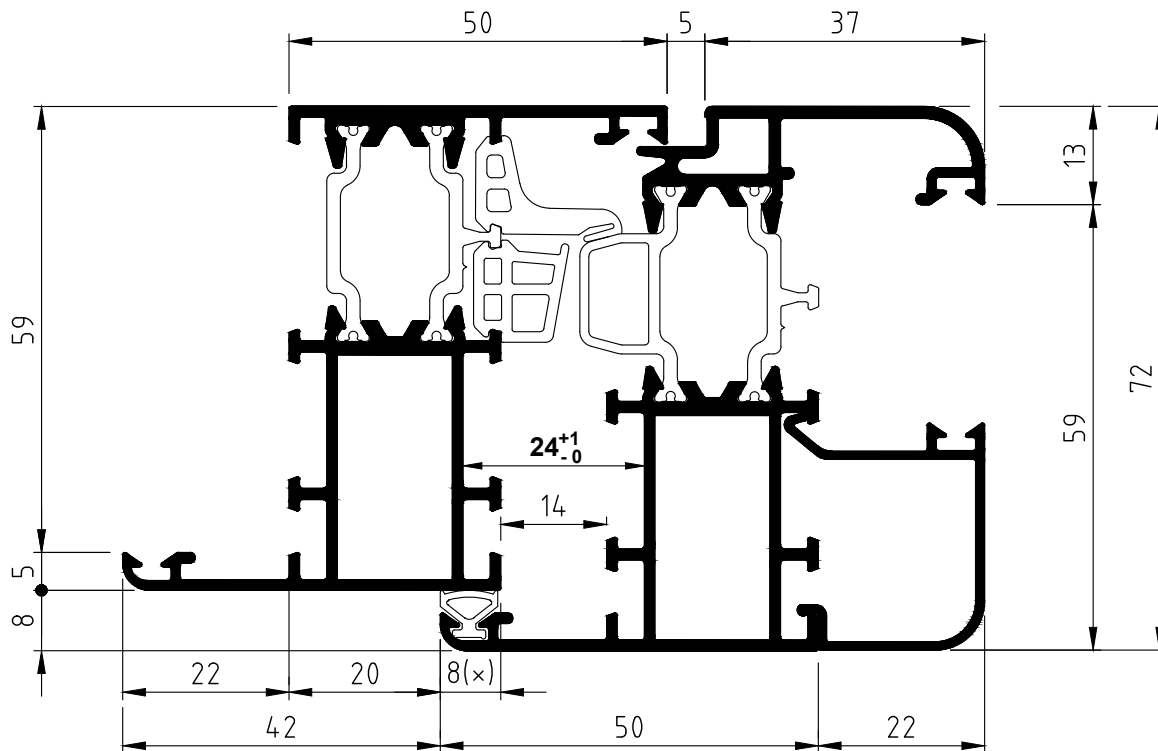

Dimensione Minima Larghezza Anta 700mm

Minimum wing width 700mm

Nel caso si debbano realizzare ante aventi dimensioni ridotte (vedi nota riportata) si consiglia di diminuire la quota di battuta da 8 mm a 7,5 mm

In case you need to realize small wings (see note). We suggest to decrease the closure dimension from 8mm to 7,5mm

N.B.:

- Le dimensioni indicate sono state ottenute considerando le quote teoriche.

N.B.:

- The dimensions indicated, are obtained considering theoretical values.

TELAJ
FRAMES

RR72C644

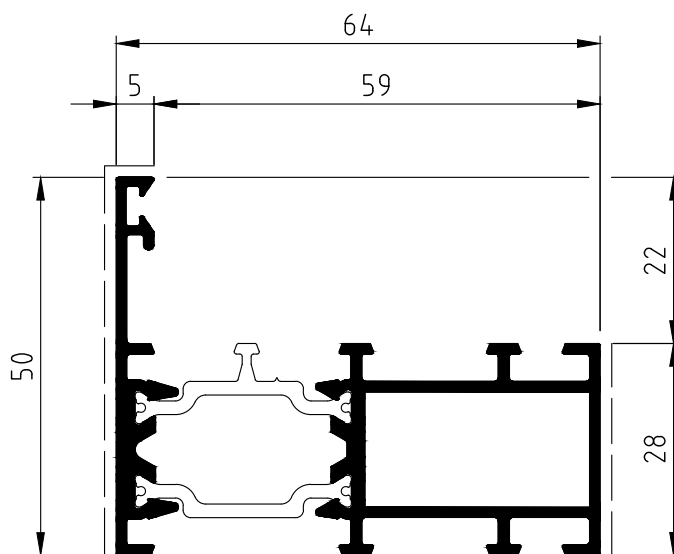

RR72C690

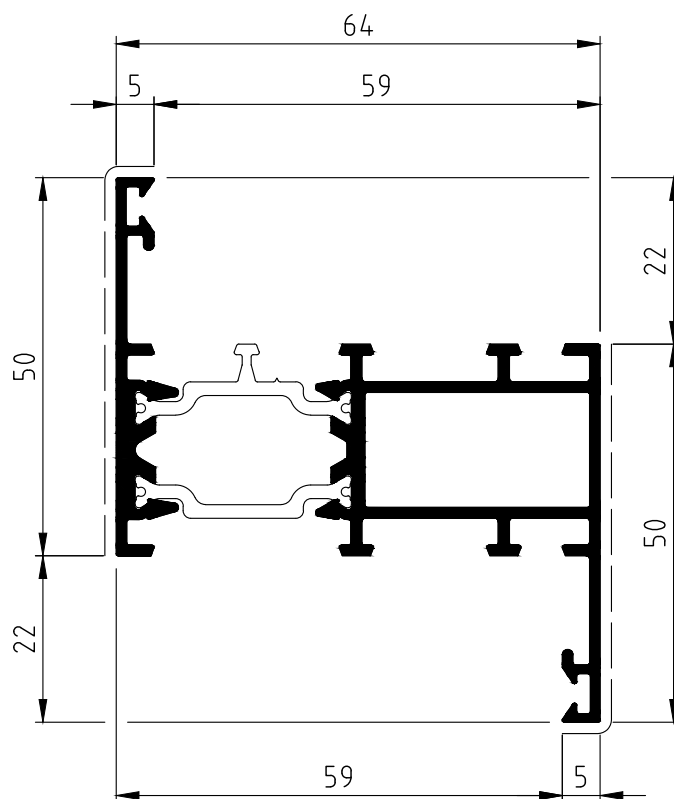

**TELAJ
FRAMES**

RR72C641

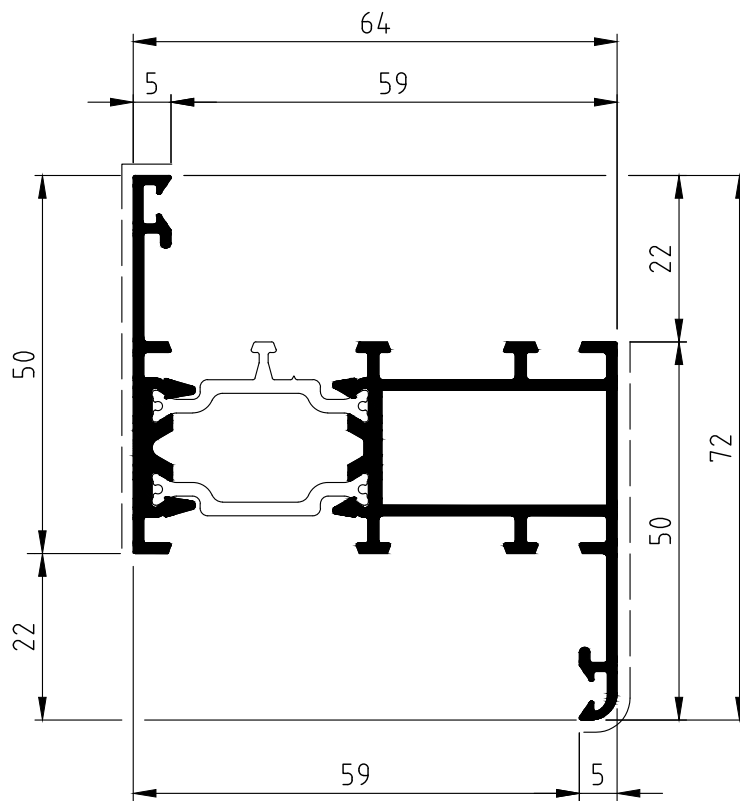

RR72C672

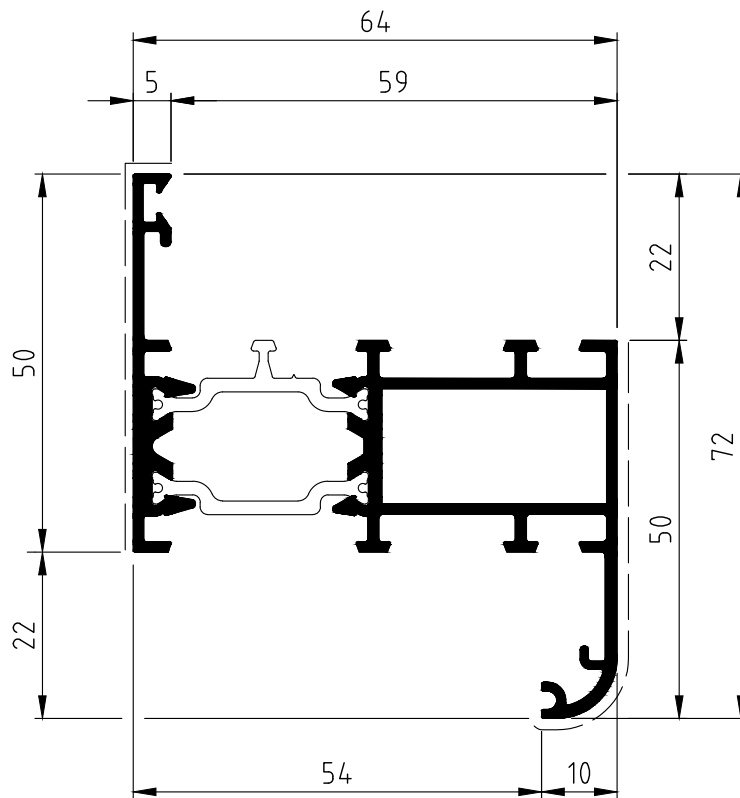

**TELAJ
FRAMES**

RR72C686

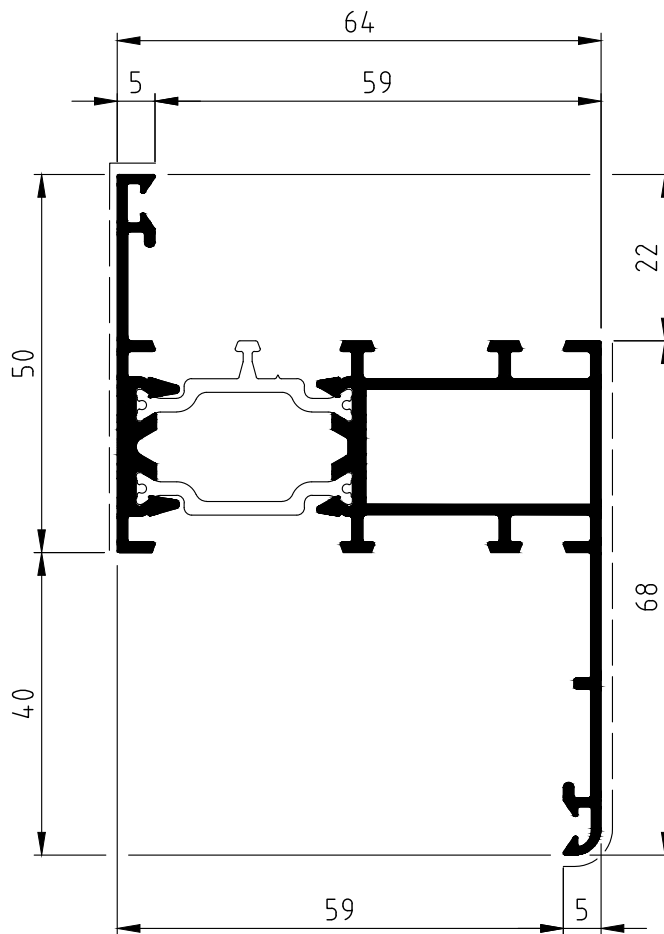

RR72C645

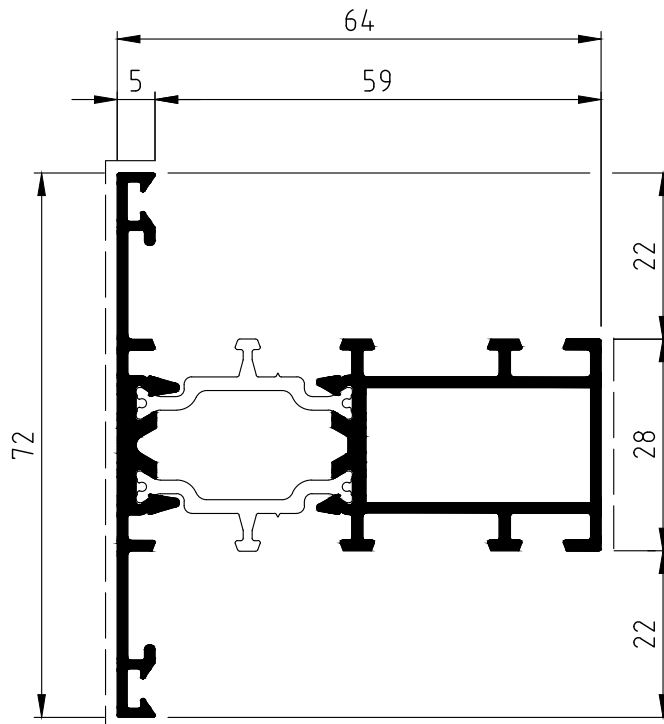

**TELAJ
FRAMES**

RR72C677

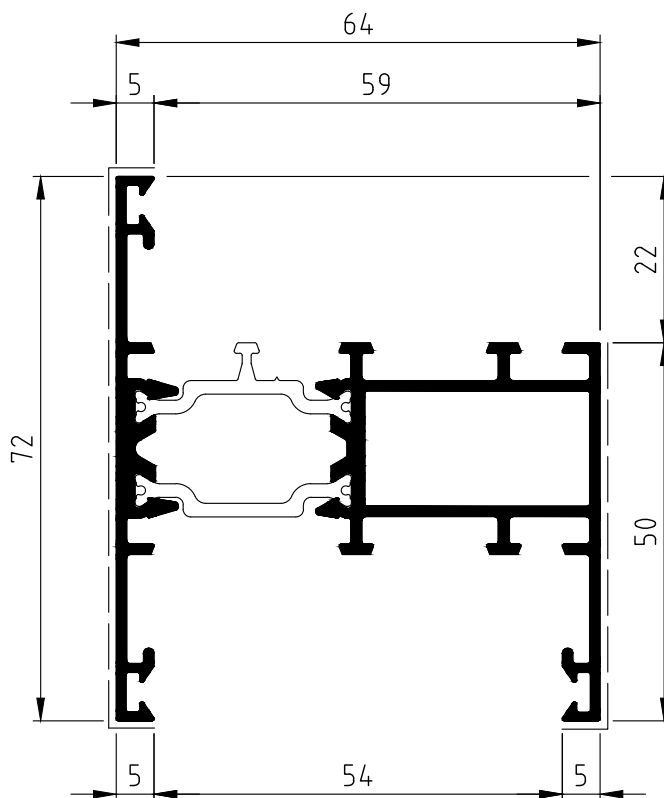

RR72C648

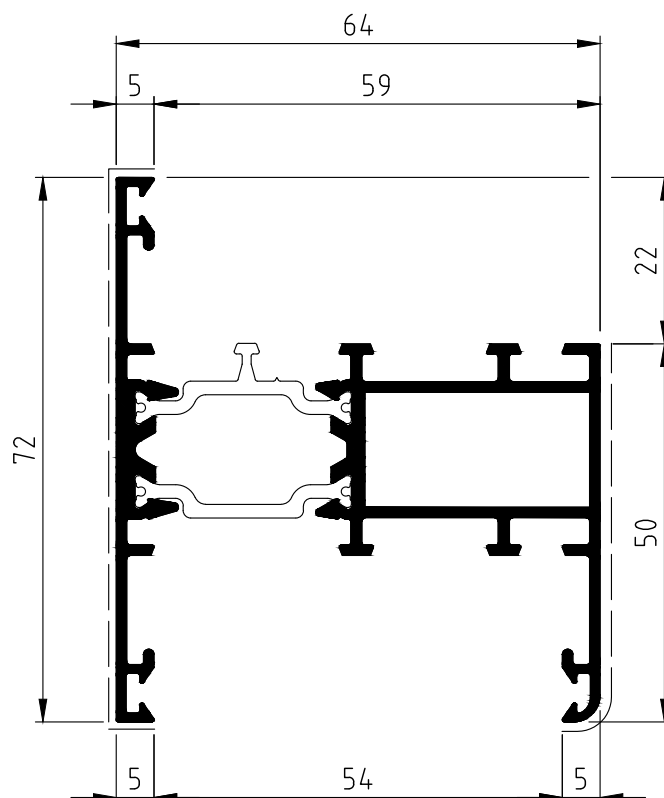

TELAJ
FRAMES

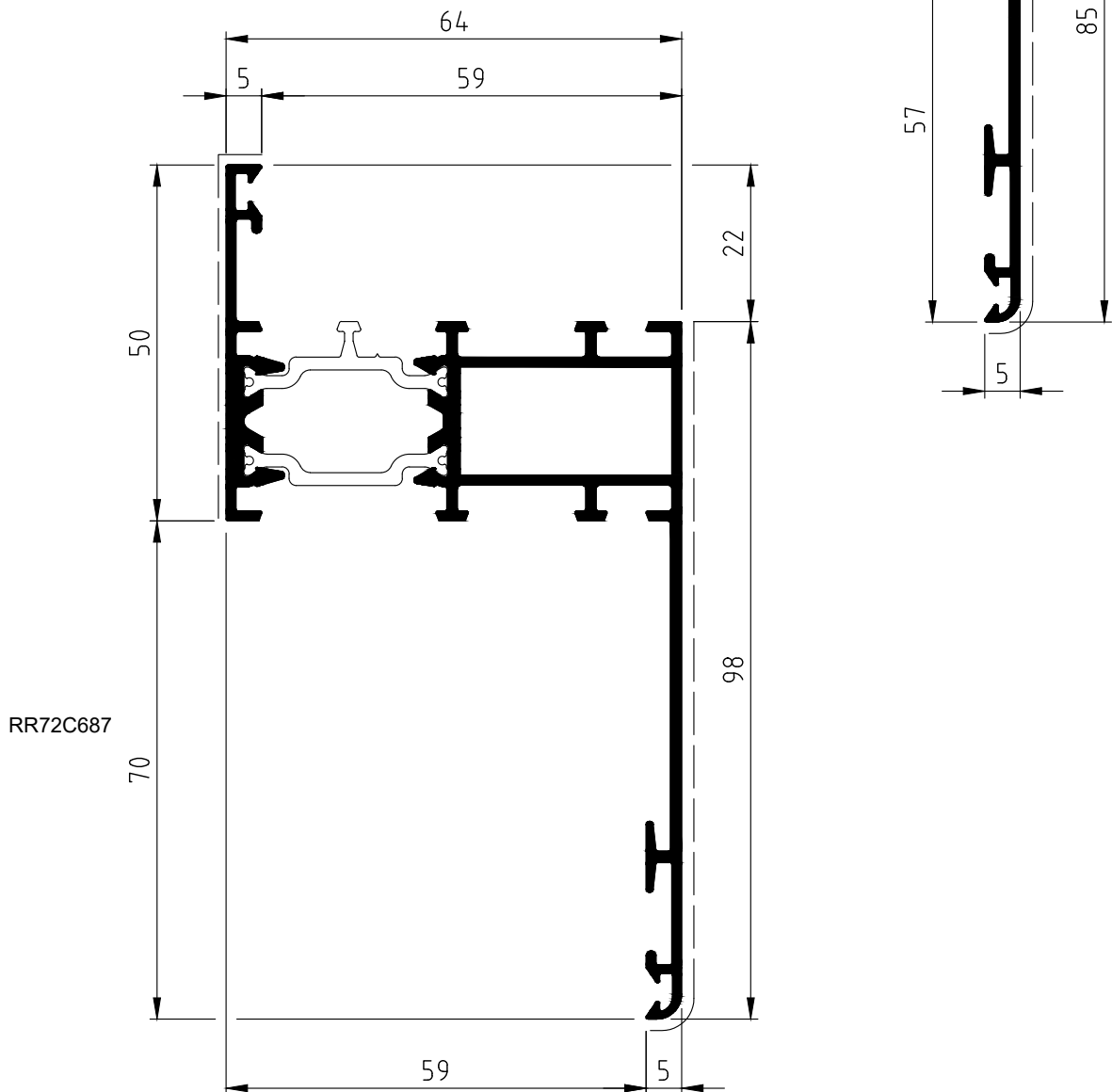
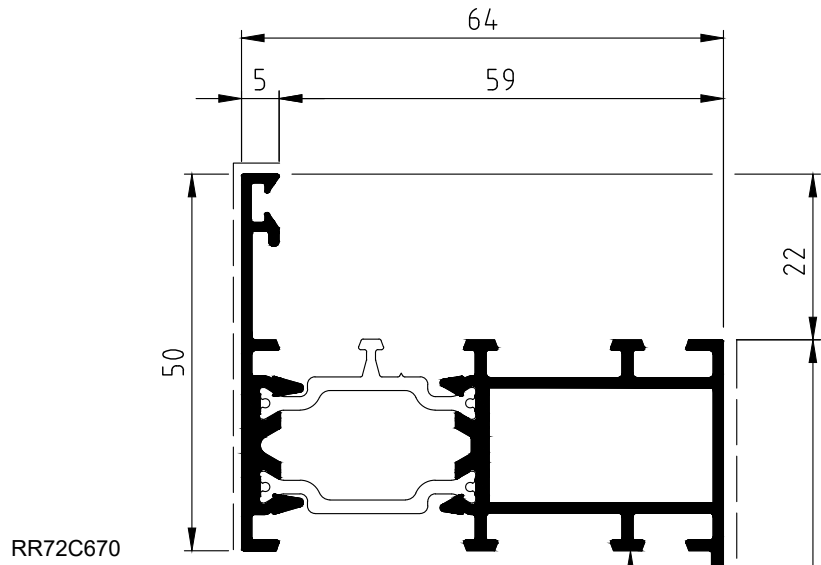

TELAJ
FRAMES

RR72C650

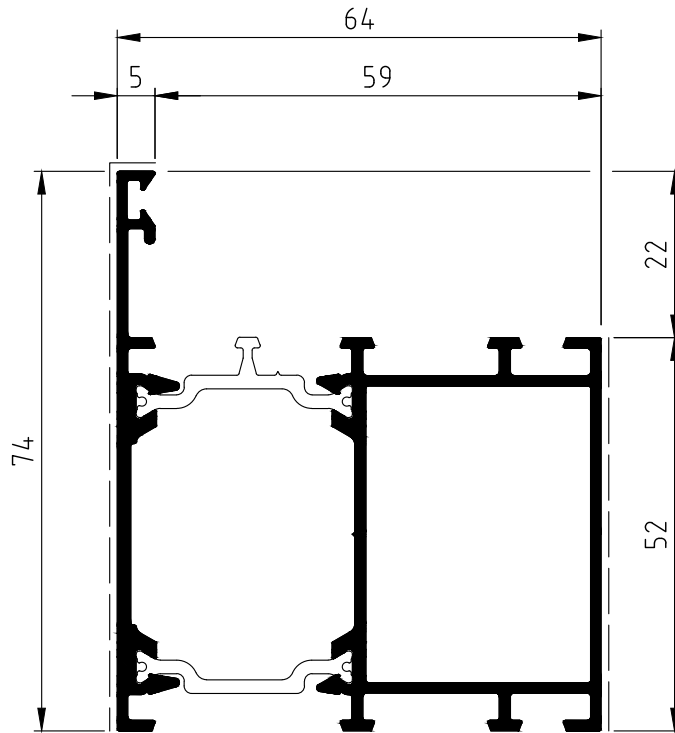

RR72C649

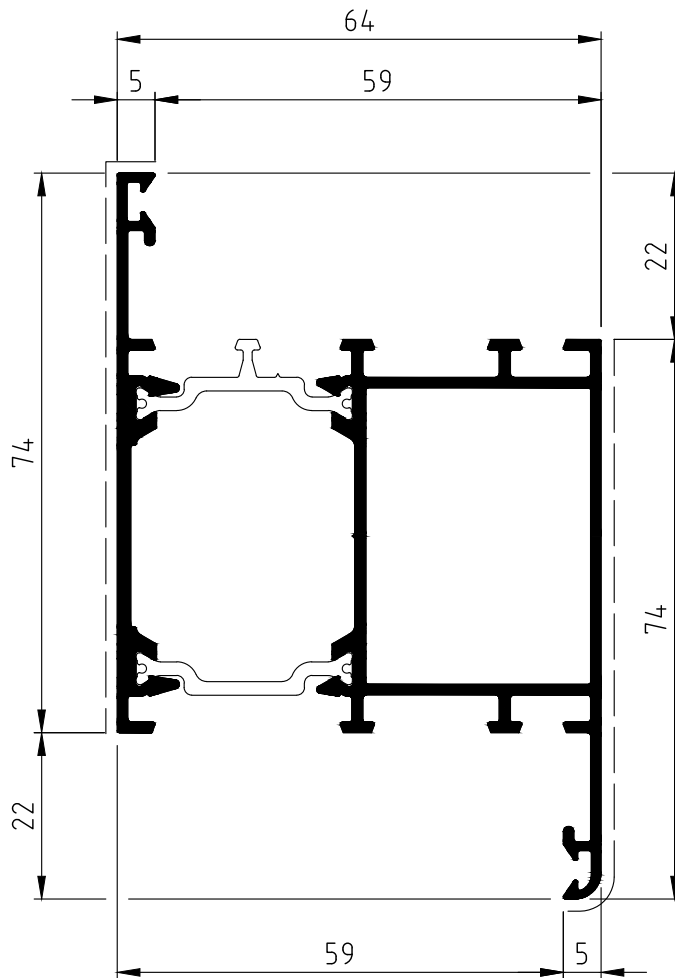

**TELAJ
FRAMES**

RR72C651

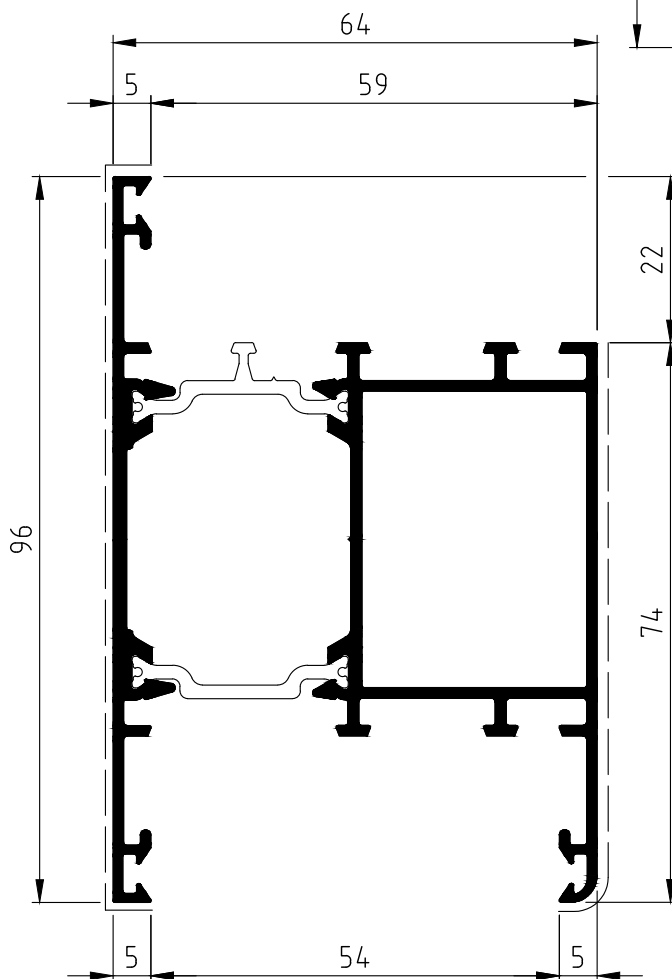
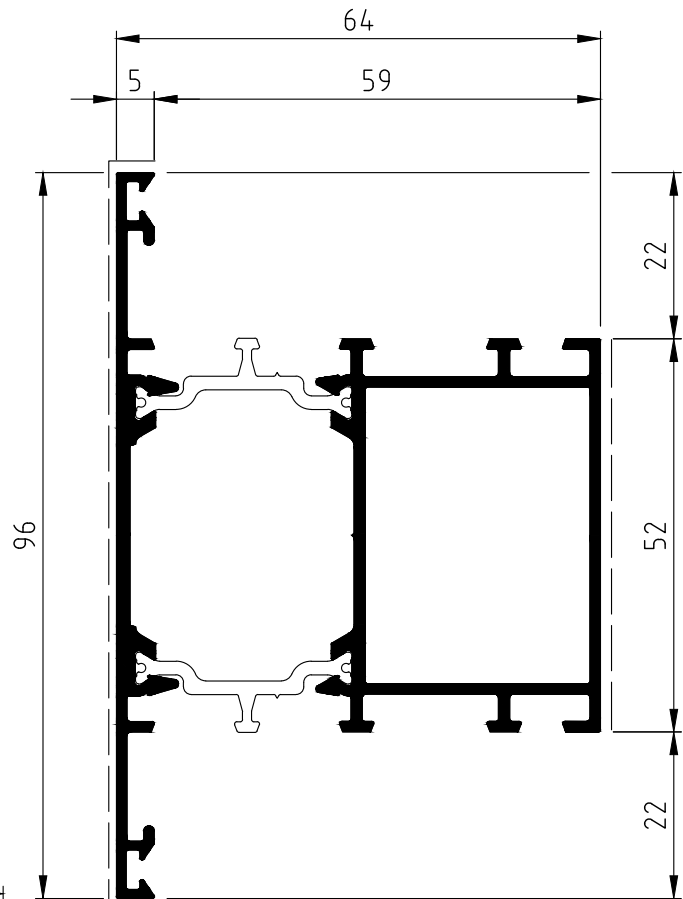

RR72C652

TELAJ
FRAMES

RR72C744

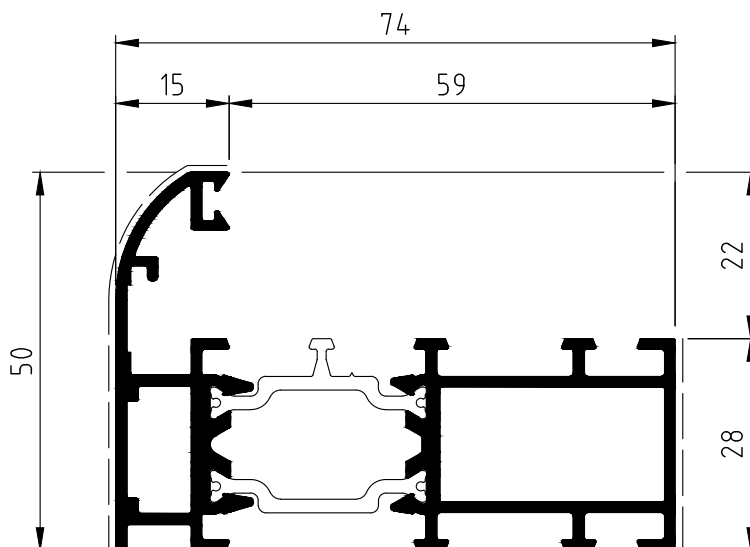

RR72C745

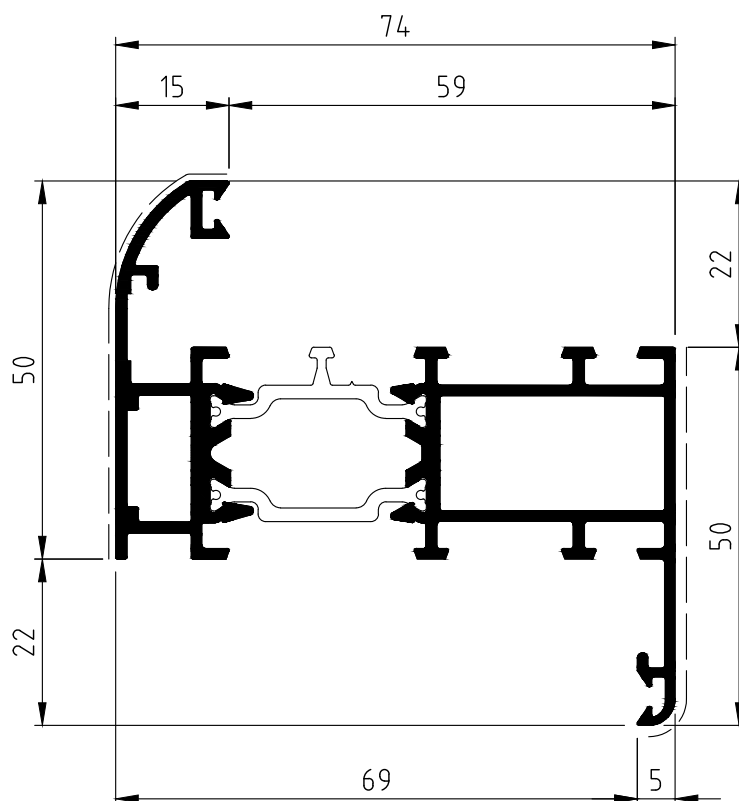

TELAJ
FRAMES

RR72C746

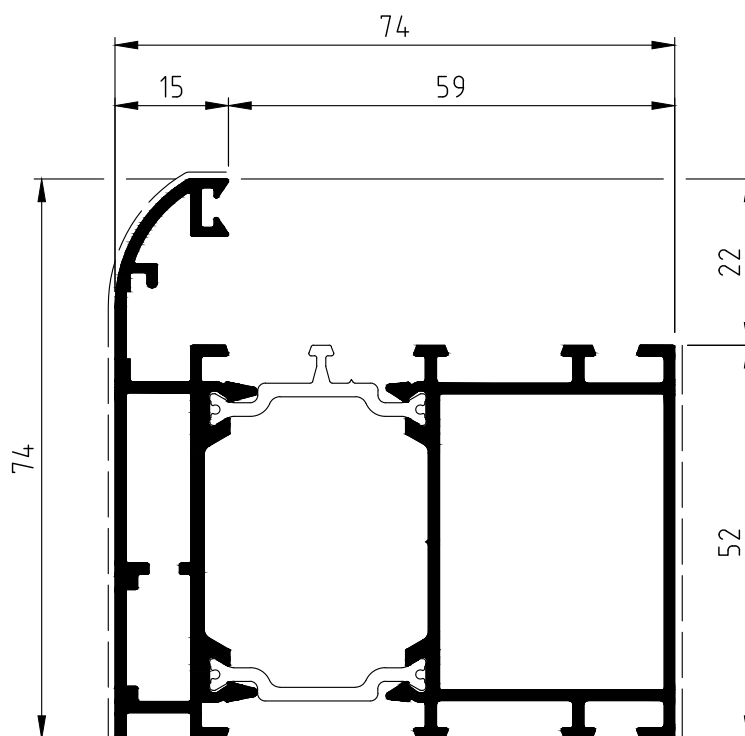

RR72C747

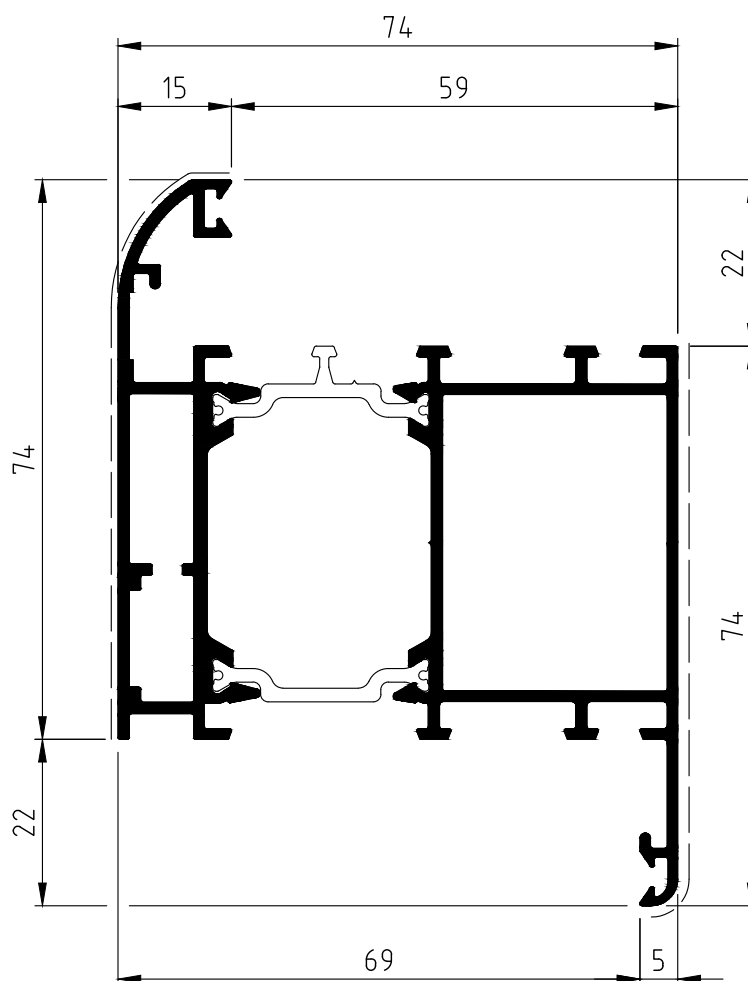

**TELAJ
FRAMES**

RR72C678

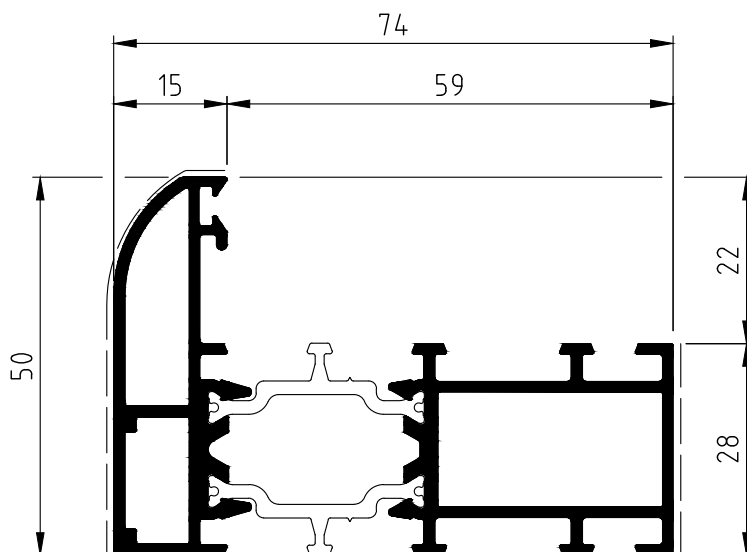

RR72C674

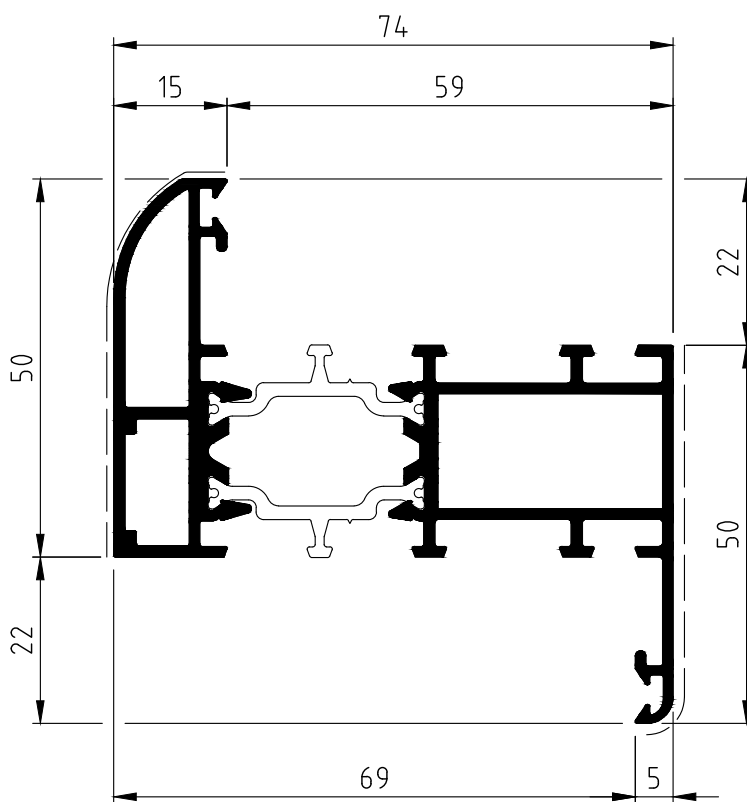

TELAJ
FRAMES

RR72C681

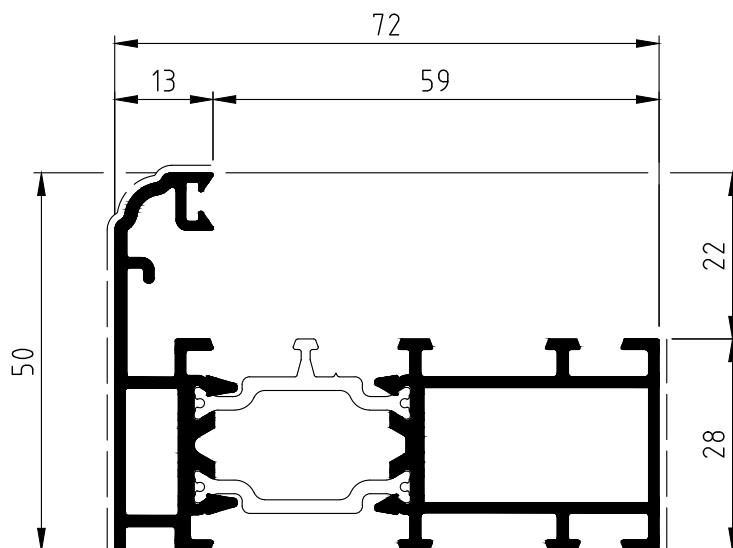

RR72C682

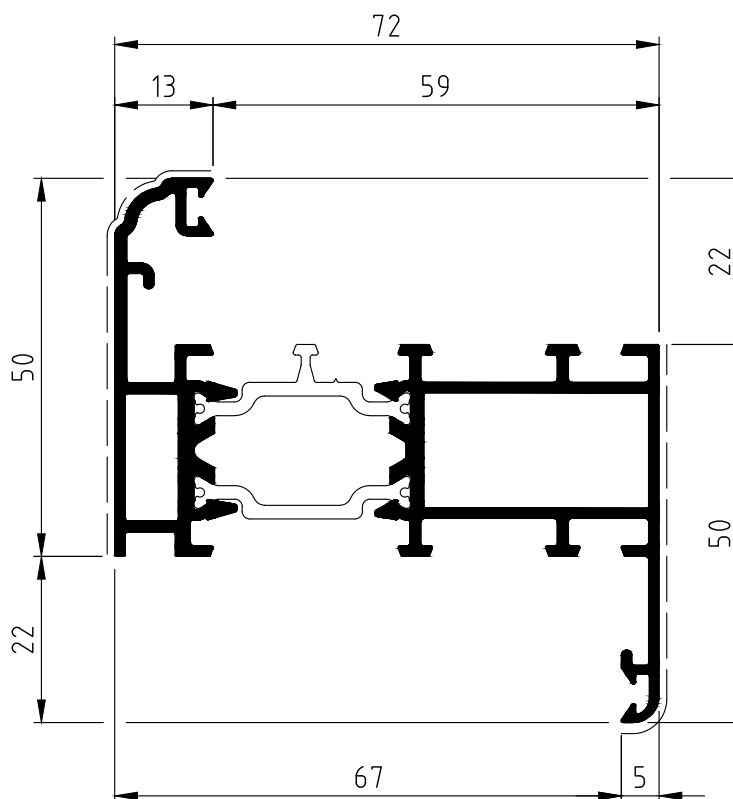

**TELAJ
FRAMES**

RR72C708

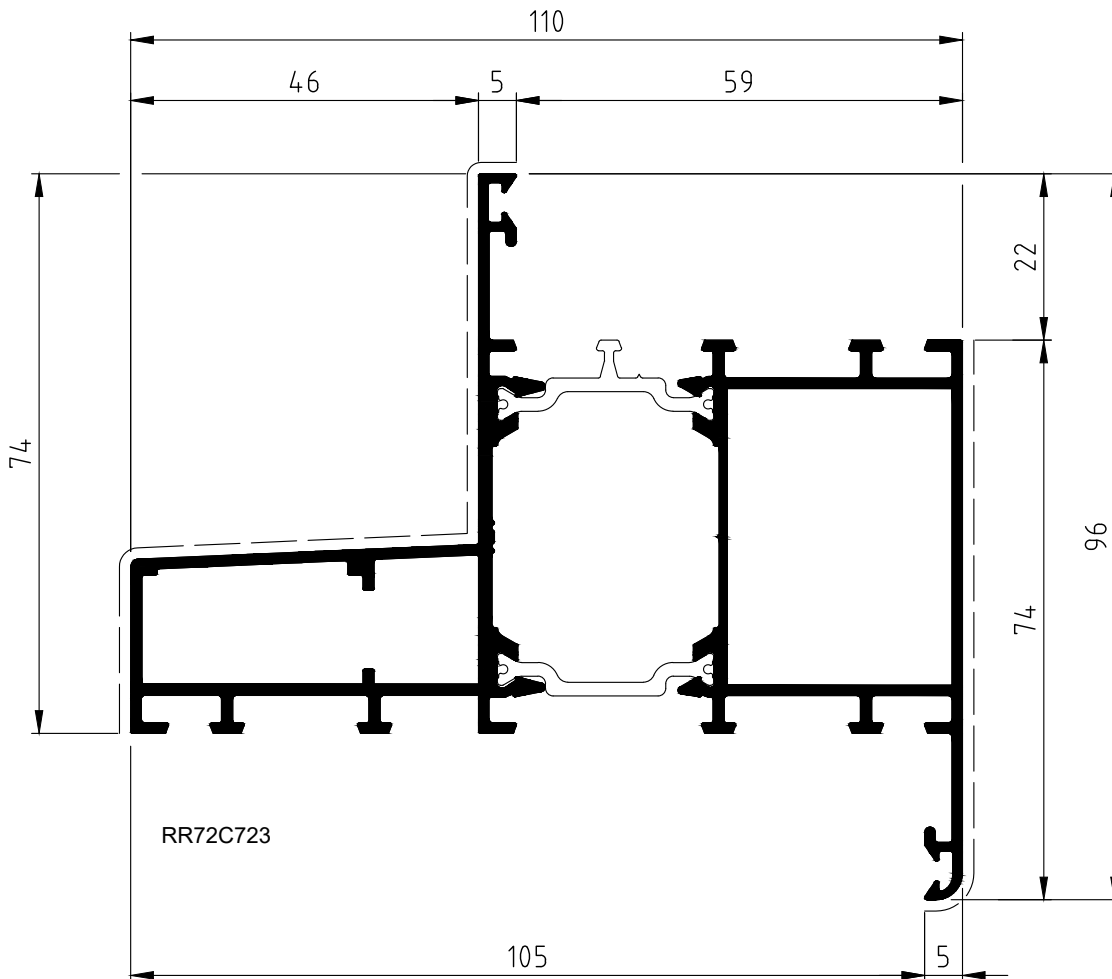
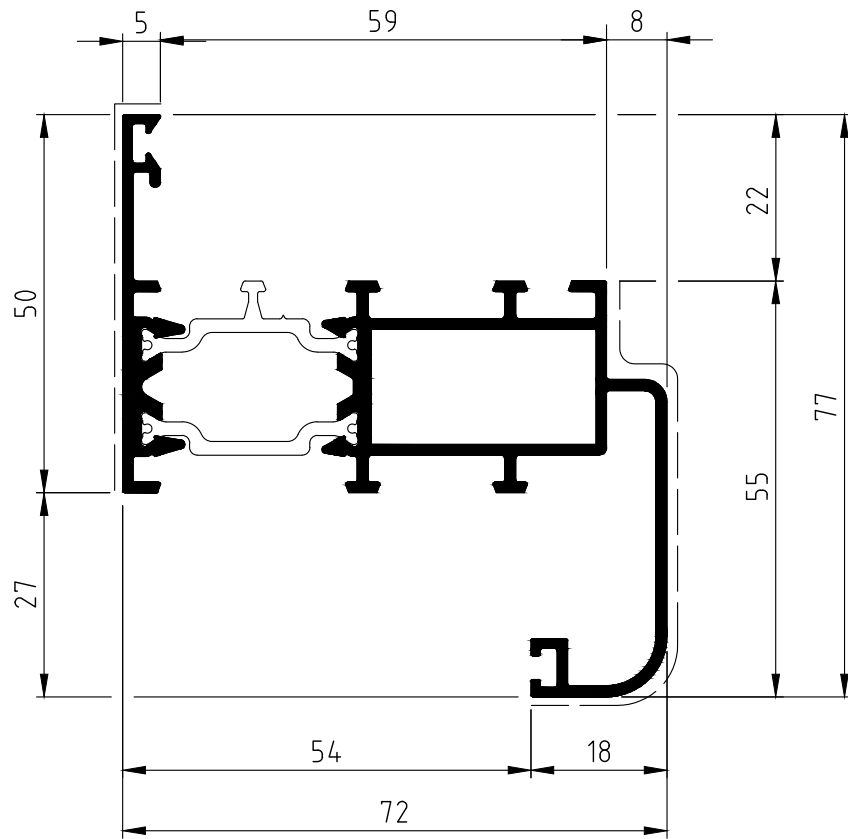

RR72C723

**ANTE
WINGS**

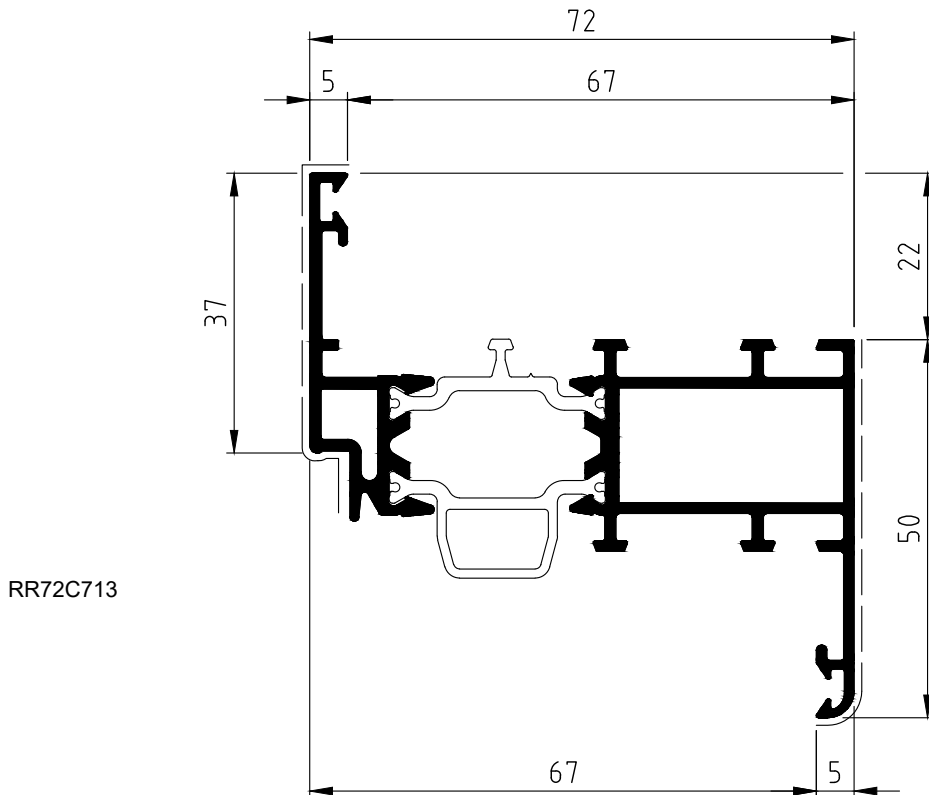
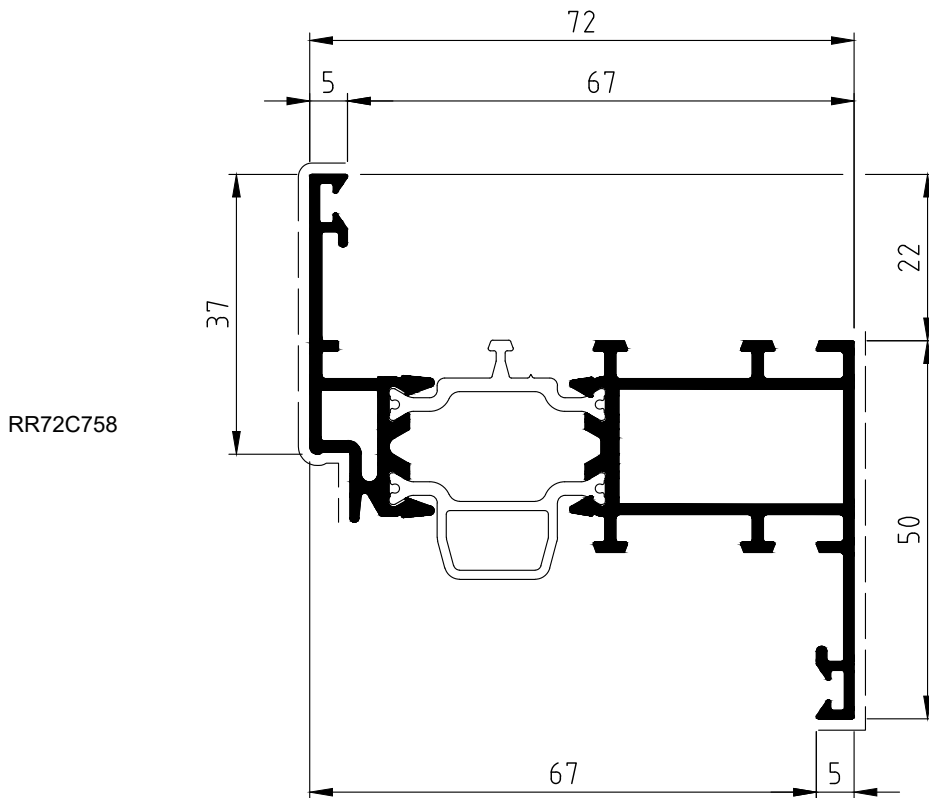

**ANTE
WINGS**

RR72C705

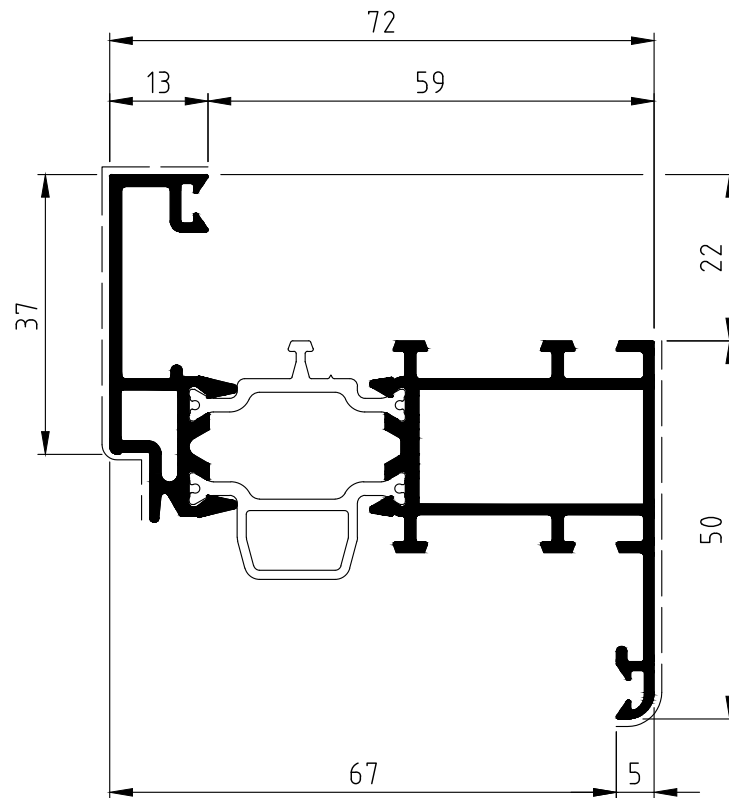

RR72C642

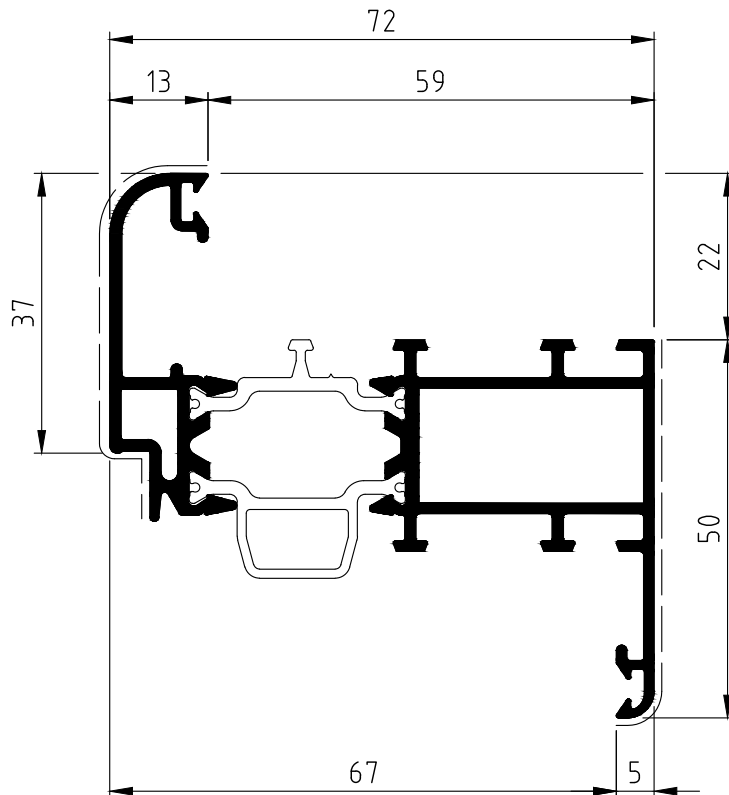

**ANTE
WINGS**

RR72C683

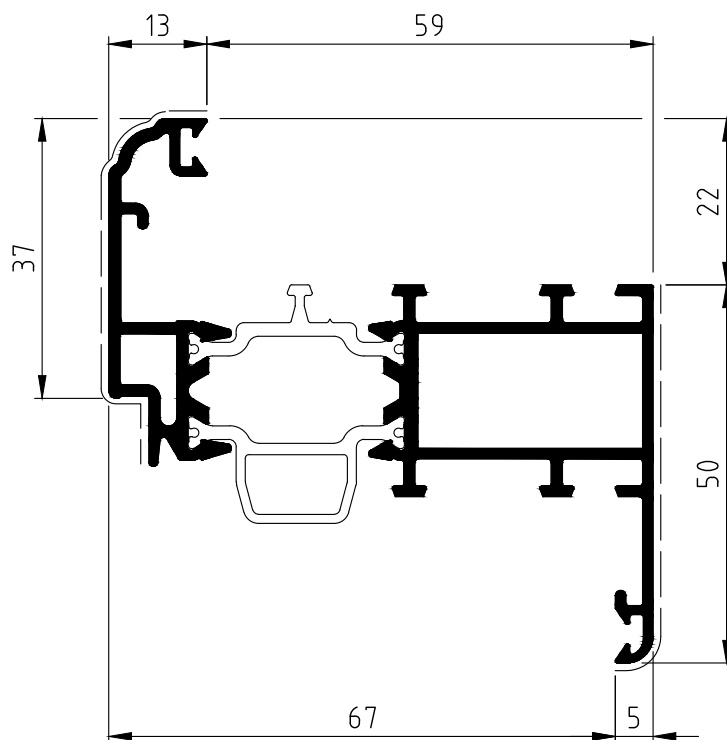

RR72C673

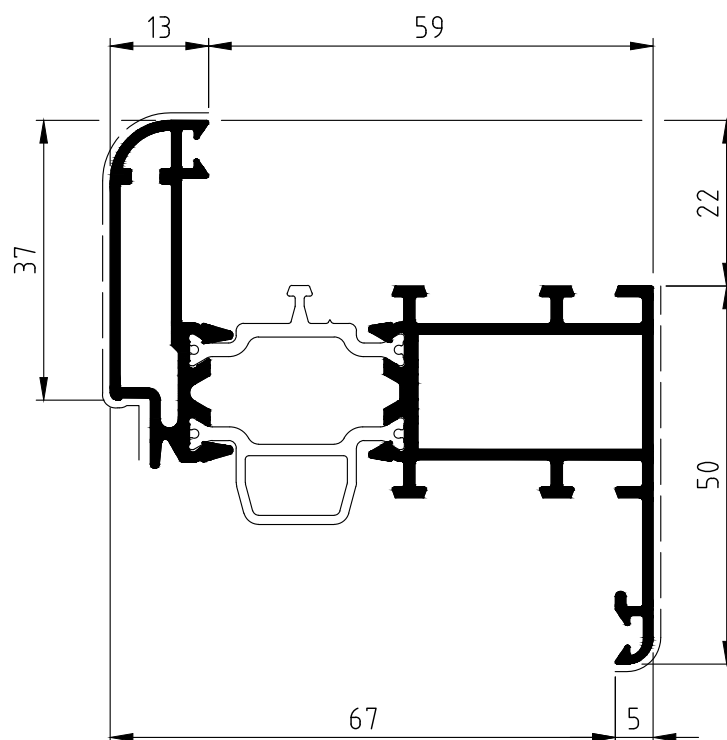

**ANTE
WINGS**

RR72C698

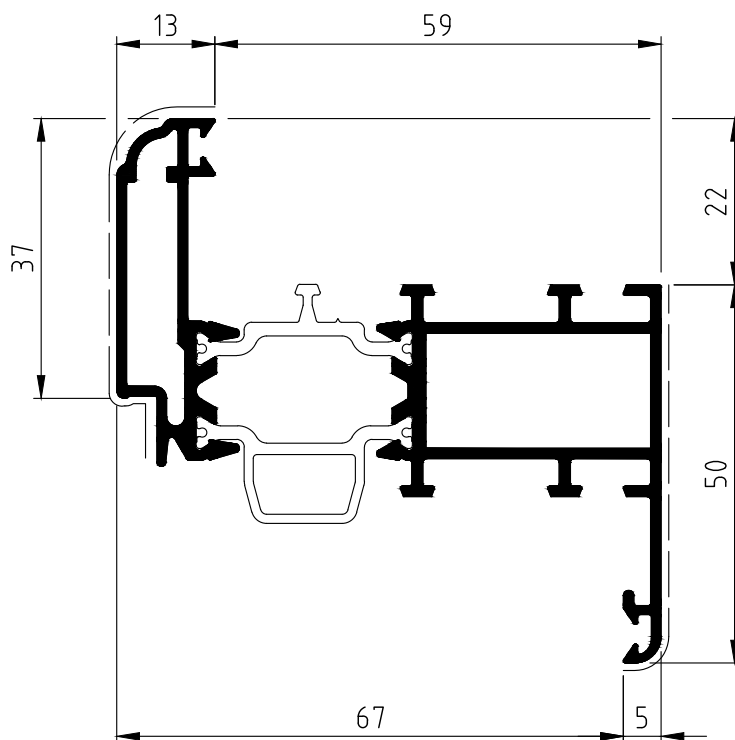

RR72C675

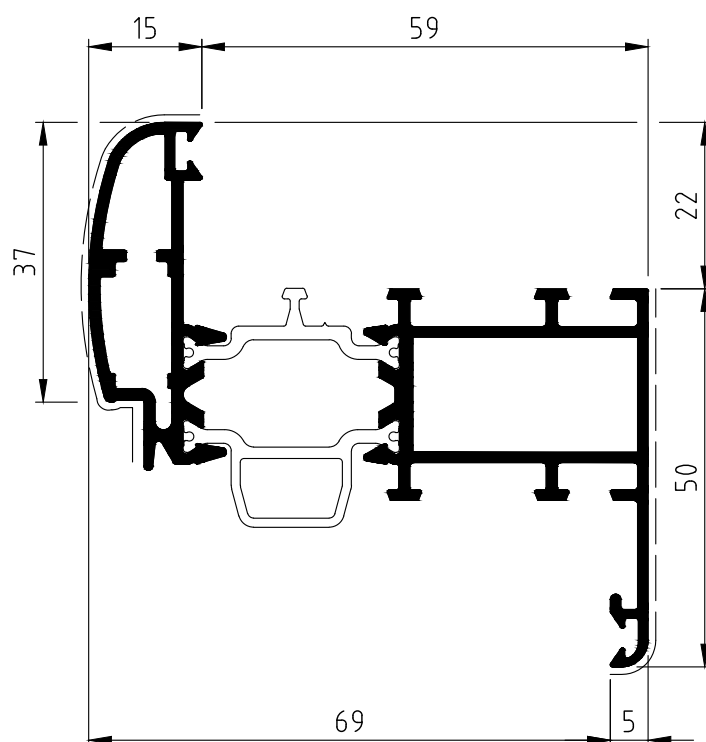

**ANTE
WINGS**

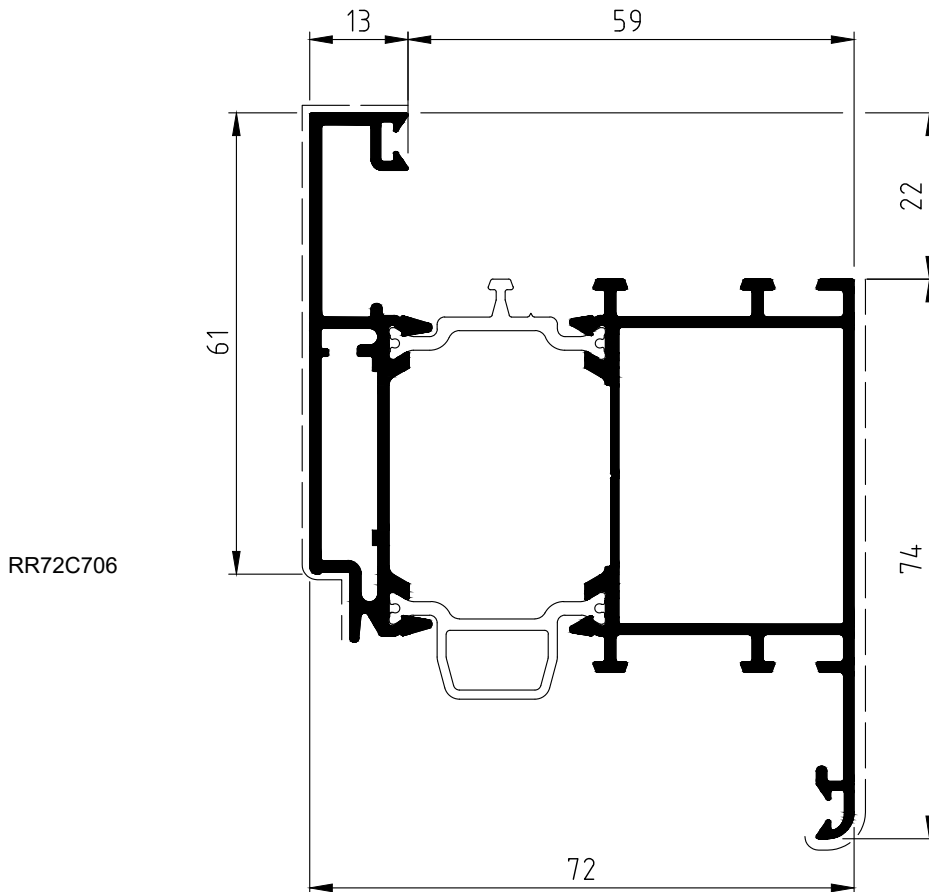
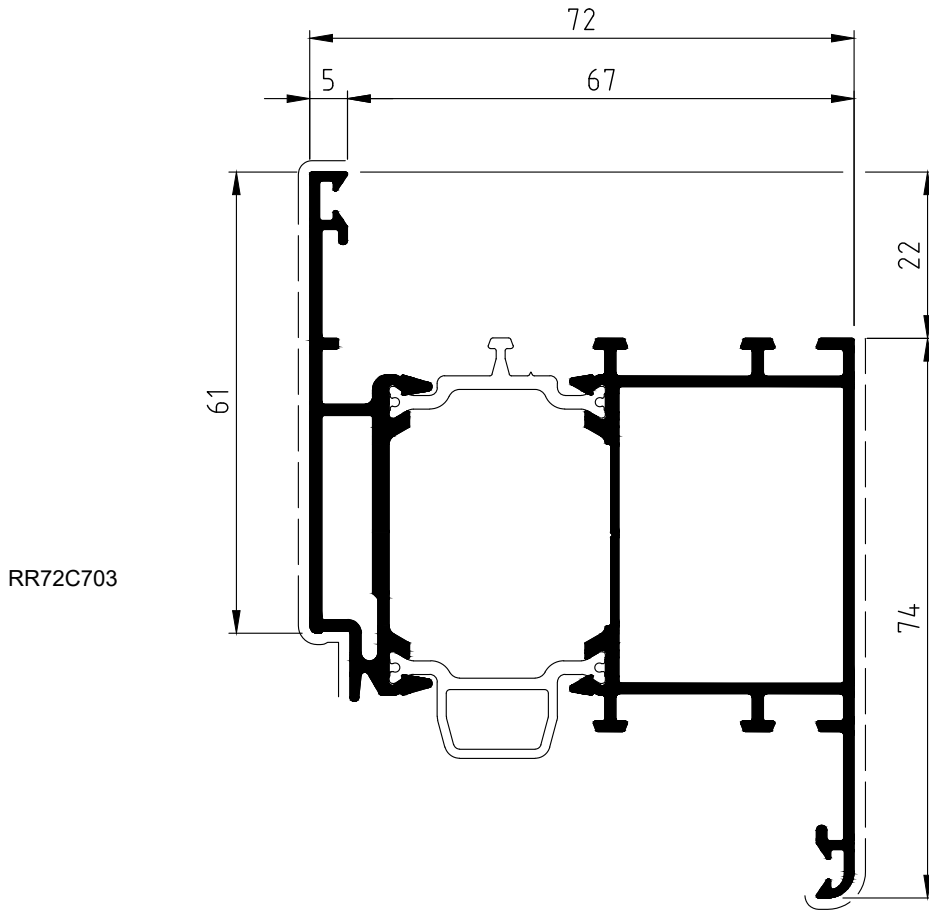

**ANTE
WINGS**

RR72C653

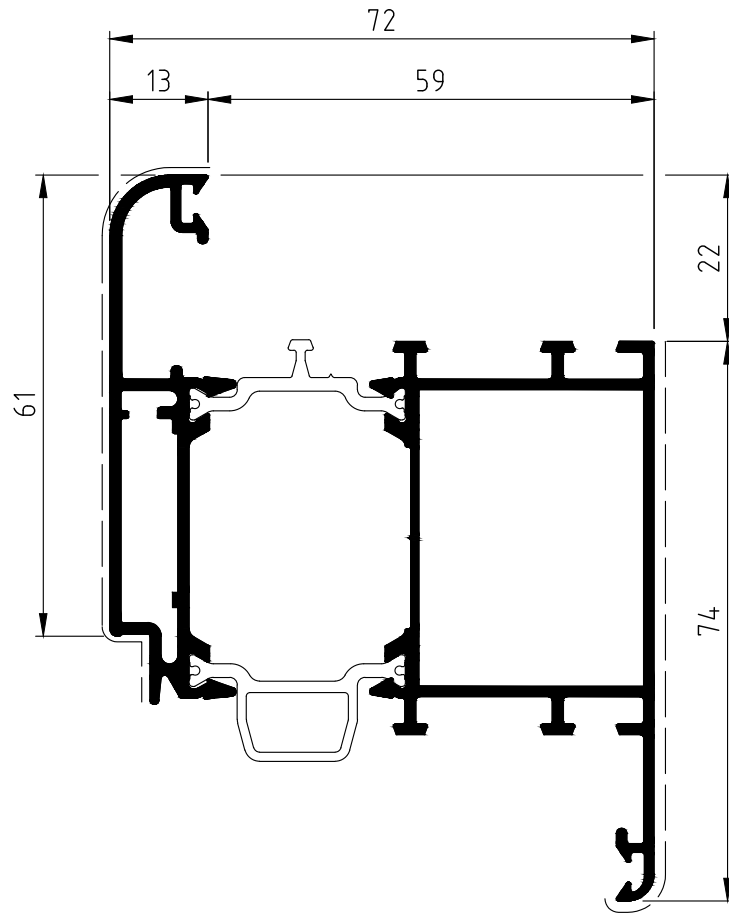

RR72C709

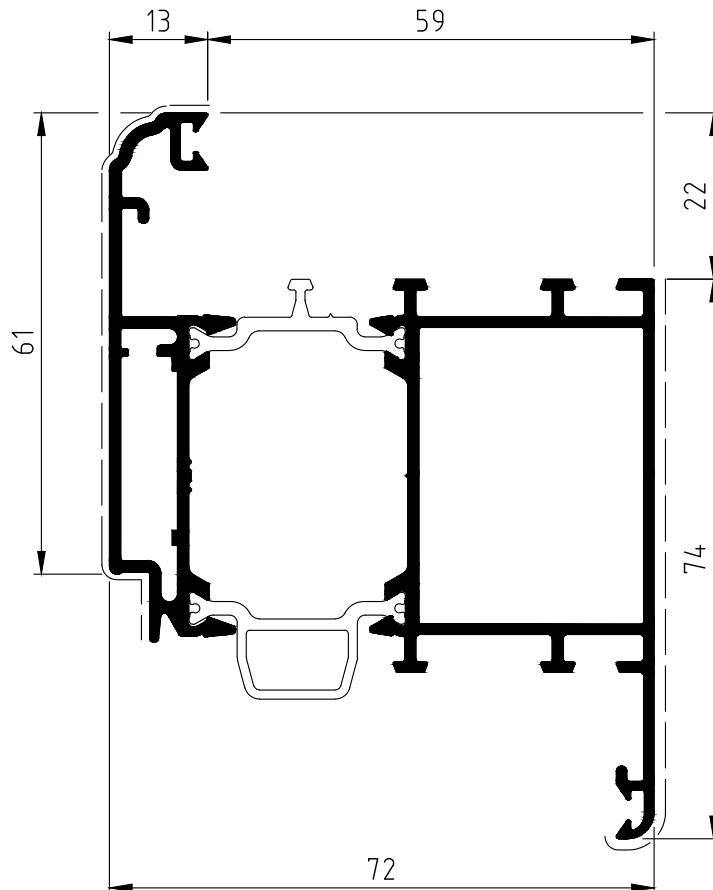

**ANTE
WINGS**

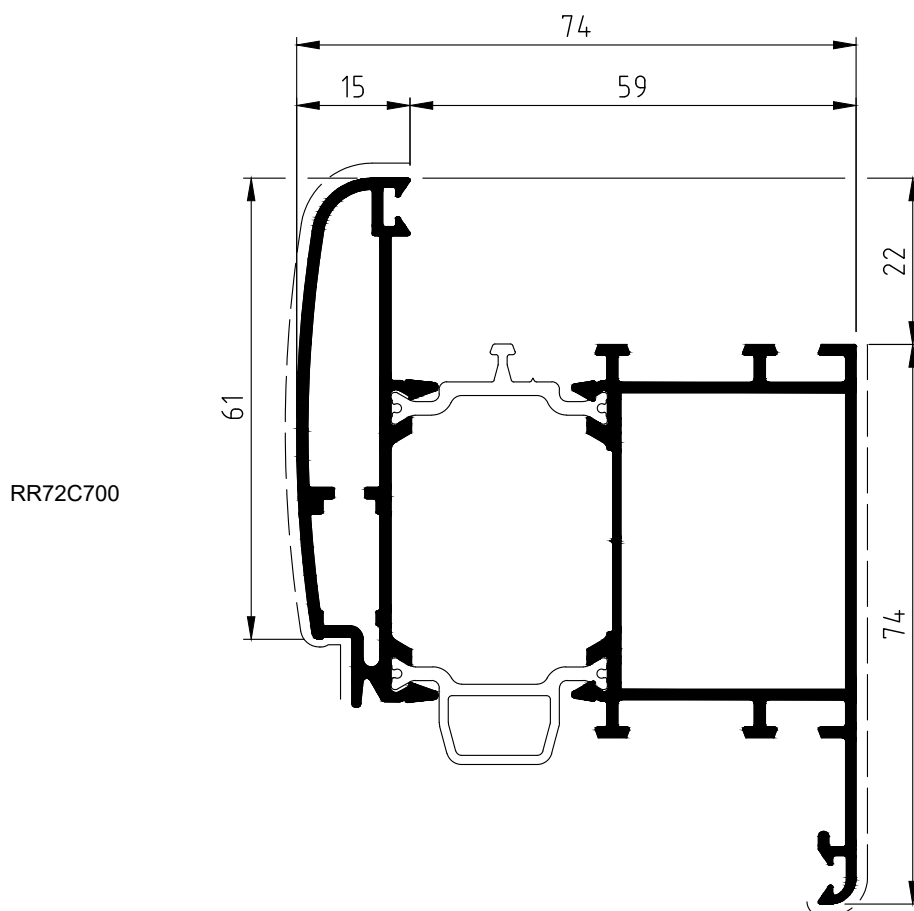

ANTE "FERRAMENTA PERIMETRALE"
WINGS "PERIMETRAL FITTING"

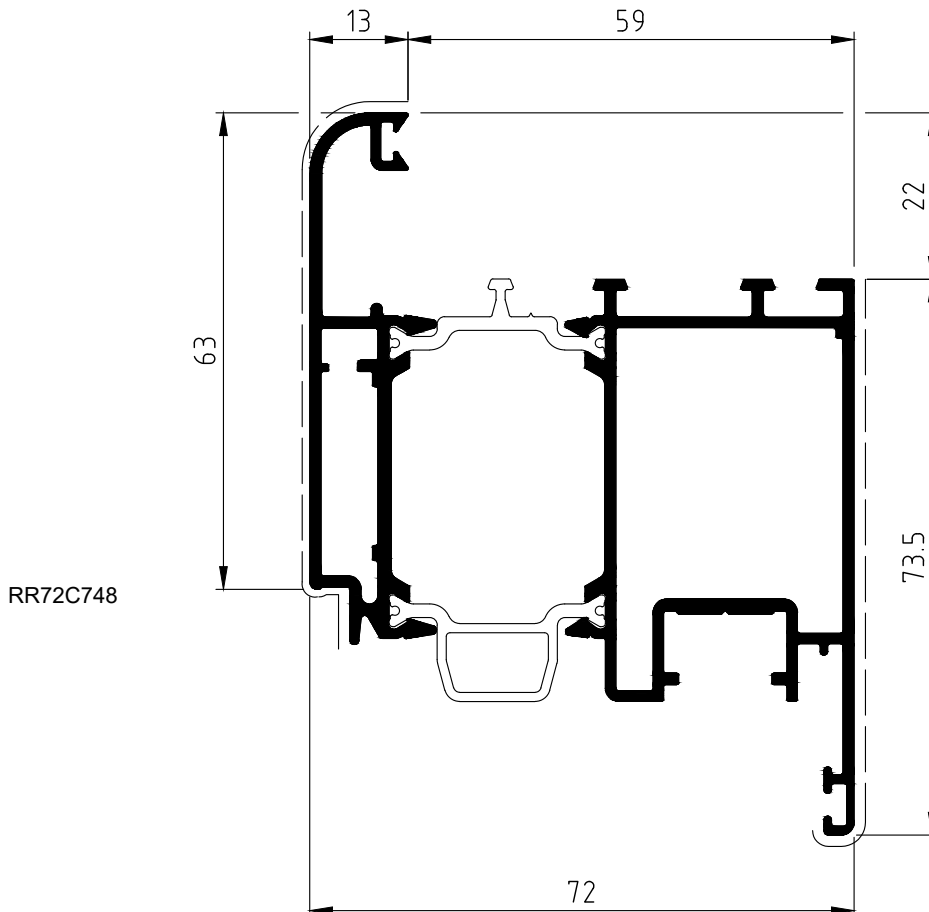
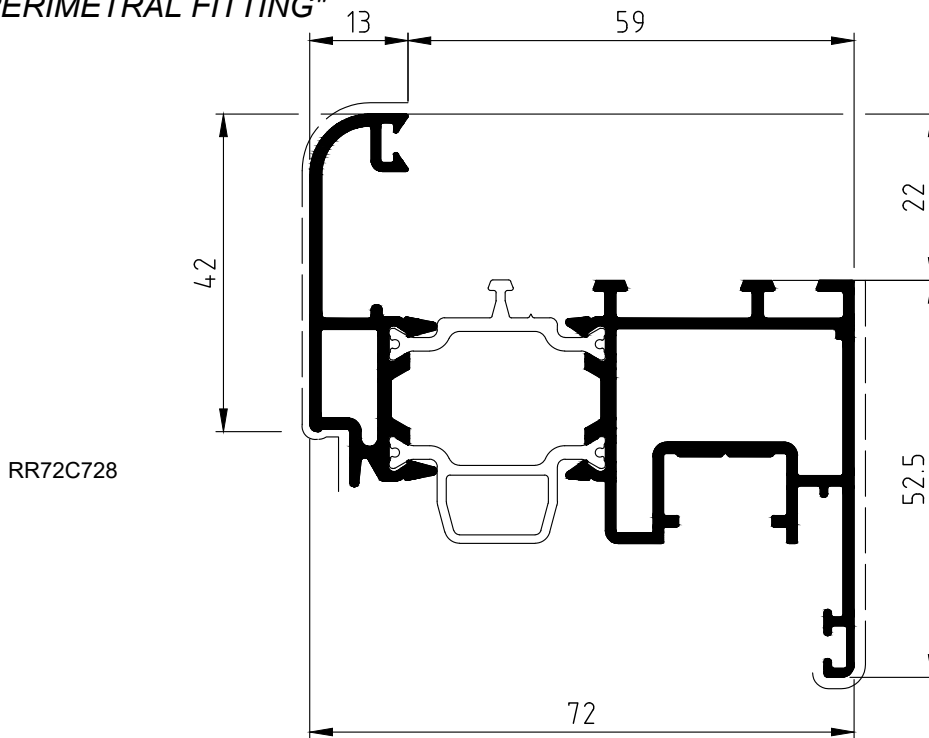

ANTE "FERRAMENTA PERIMETRALE"
WINGS "PERIMETRAL FITTING"

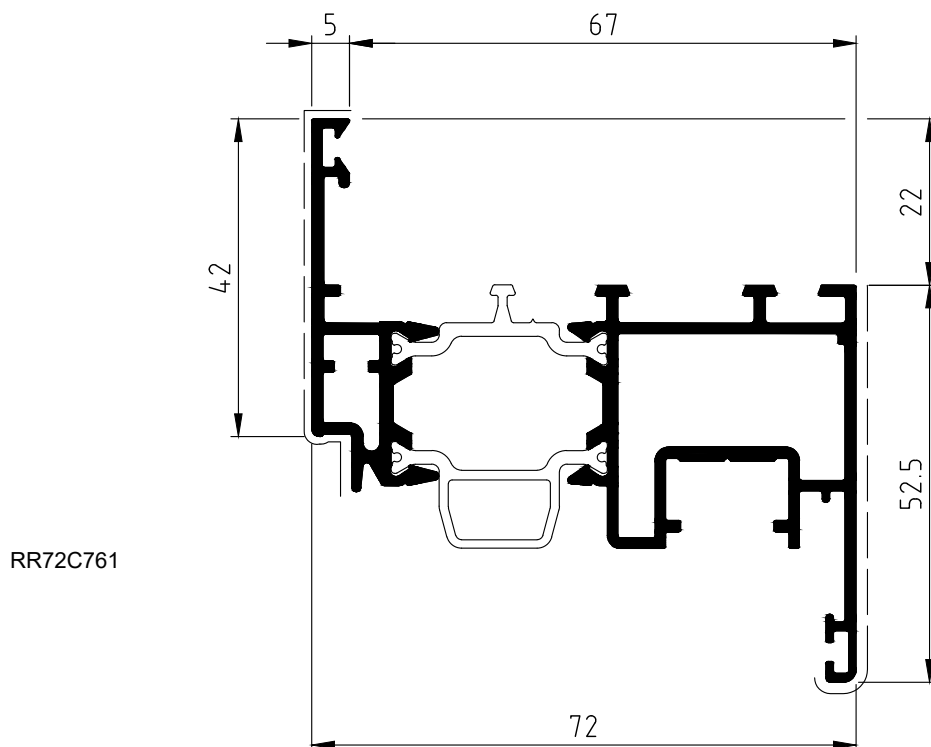
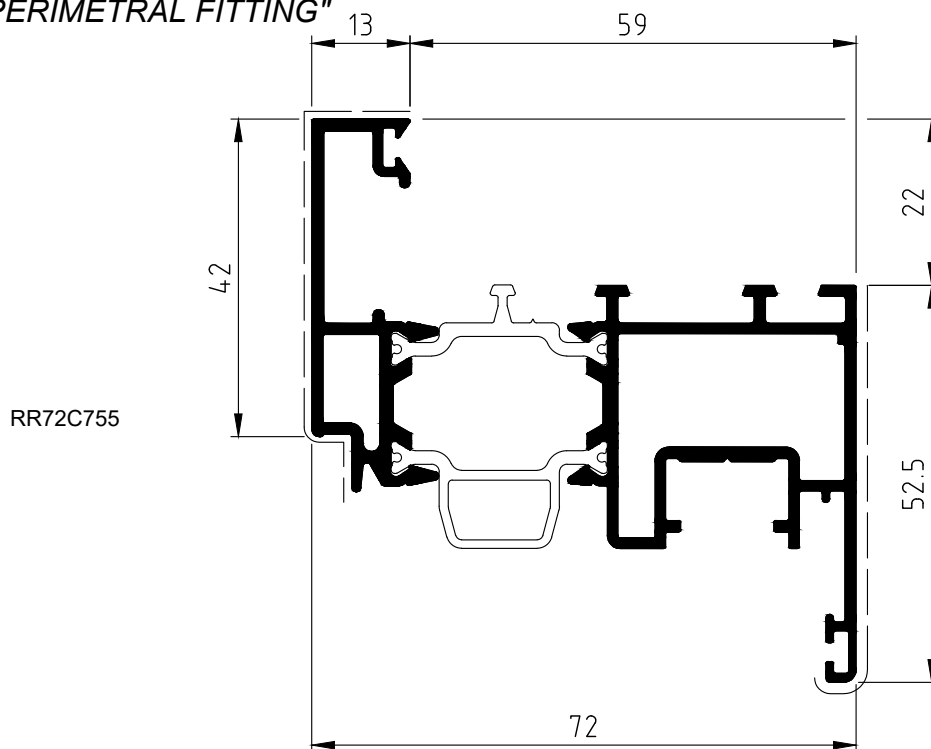

RIPORTO CENTRALE
CENTRAL FILLING

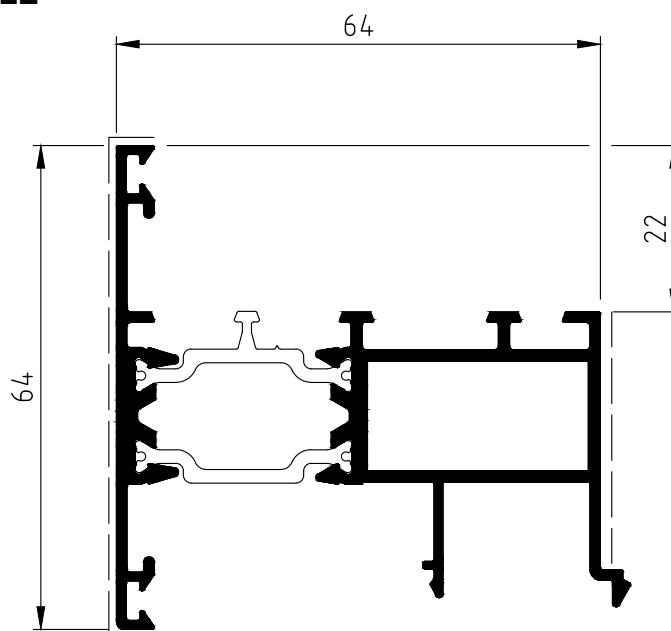

RR72C643

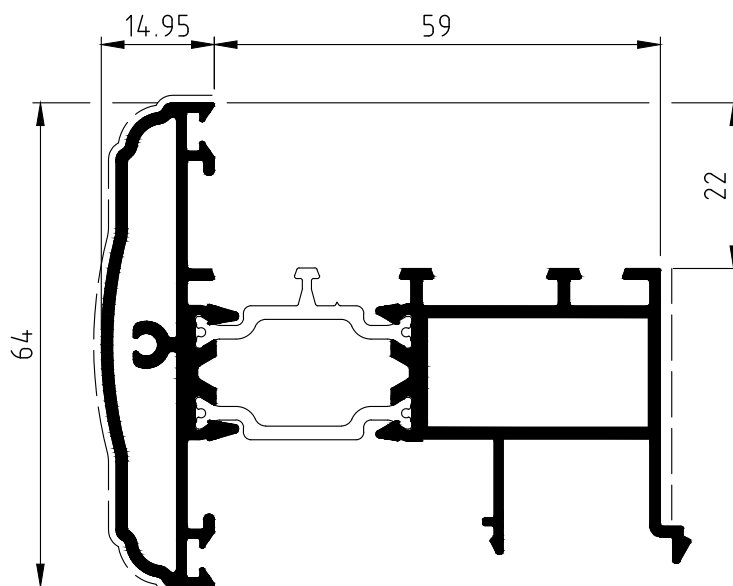

RR72C684

RIPORTO CENTRALE
CENTRAL FILLING

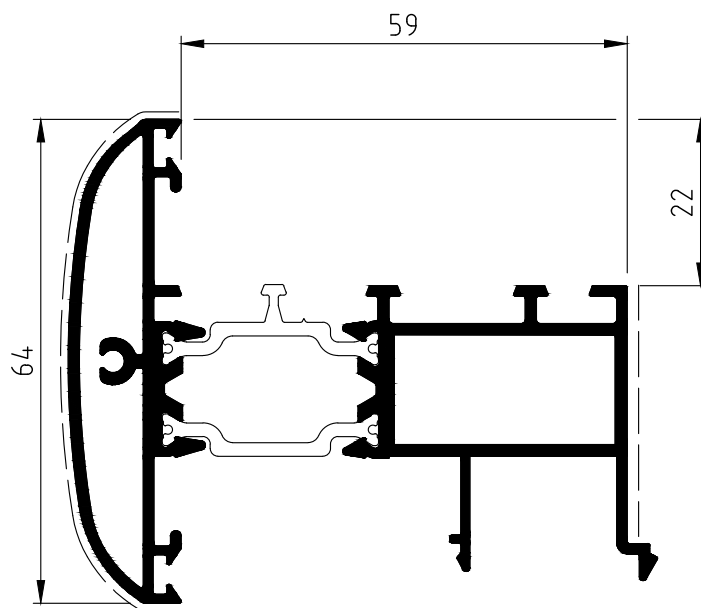

RR72C676

RIP. CENTR. "FERRAMENTA PERIMETRALE"
CENTRAL FILLING "PERIMETRAL FITTING"

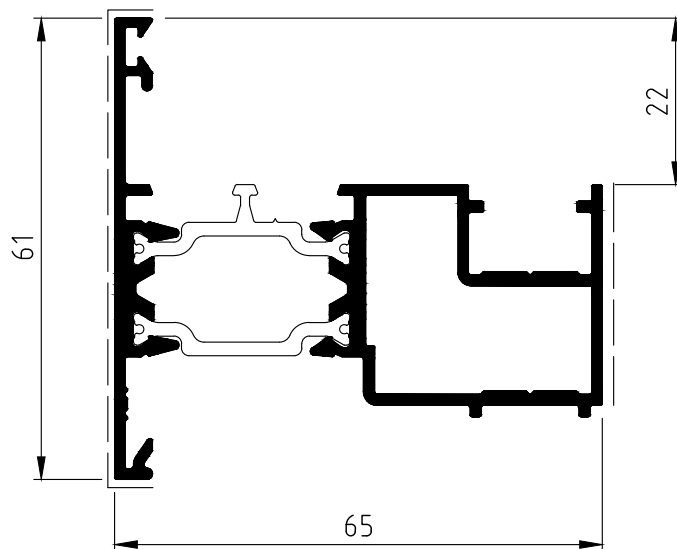

RR72C729

TELAI SPECIALI
SPECIAL FRAMES

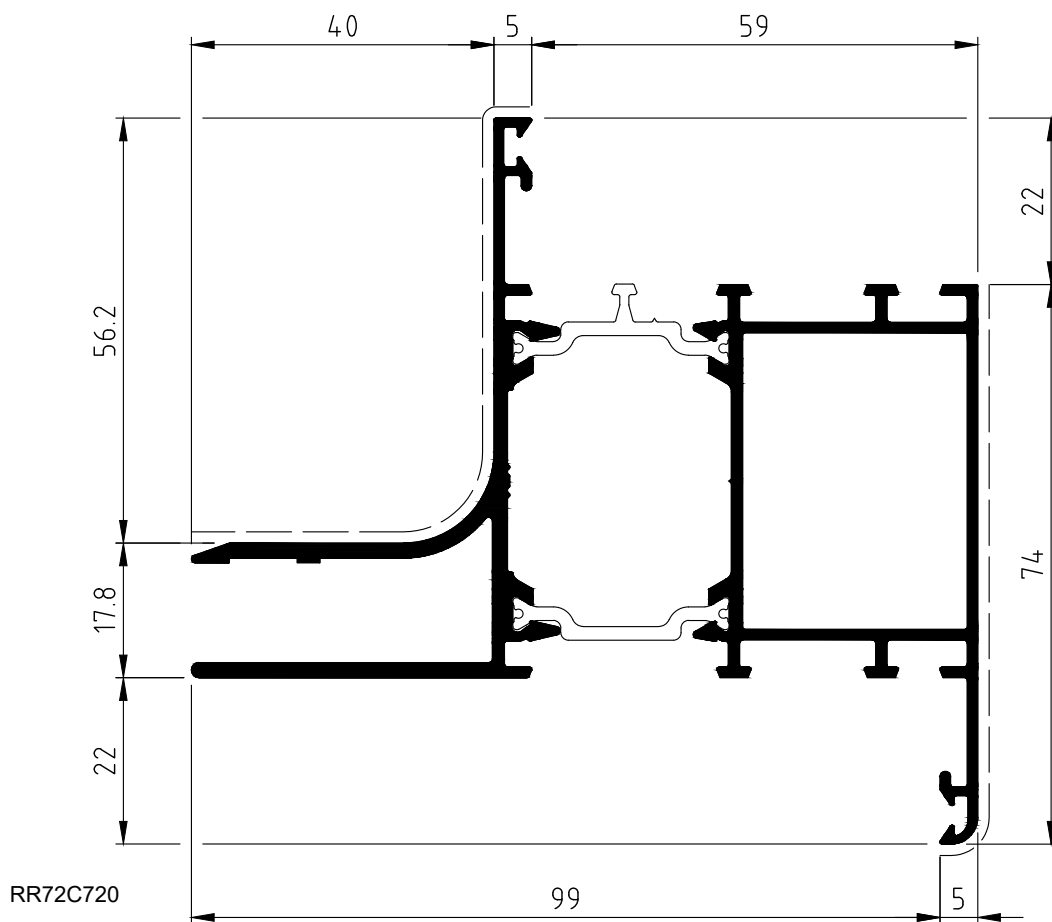
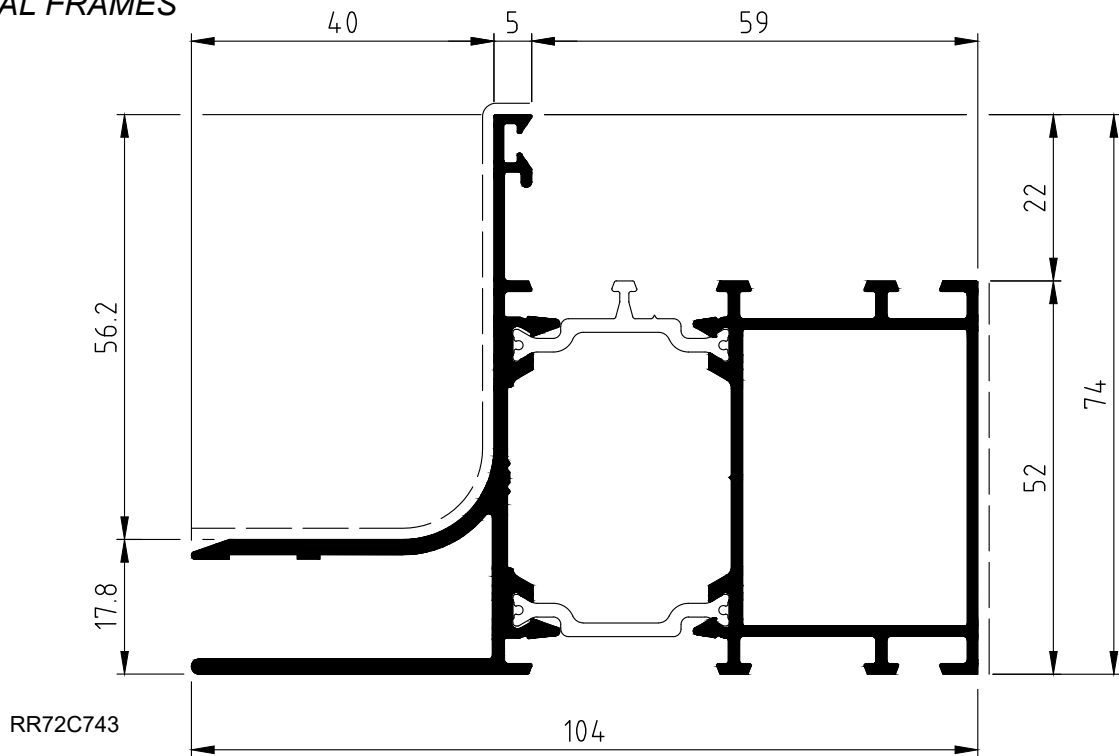

TELAI SPECIALI
SPECIAL FRAMES

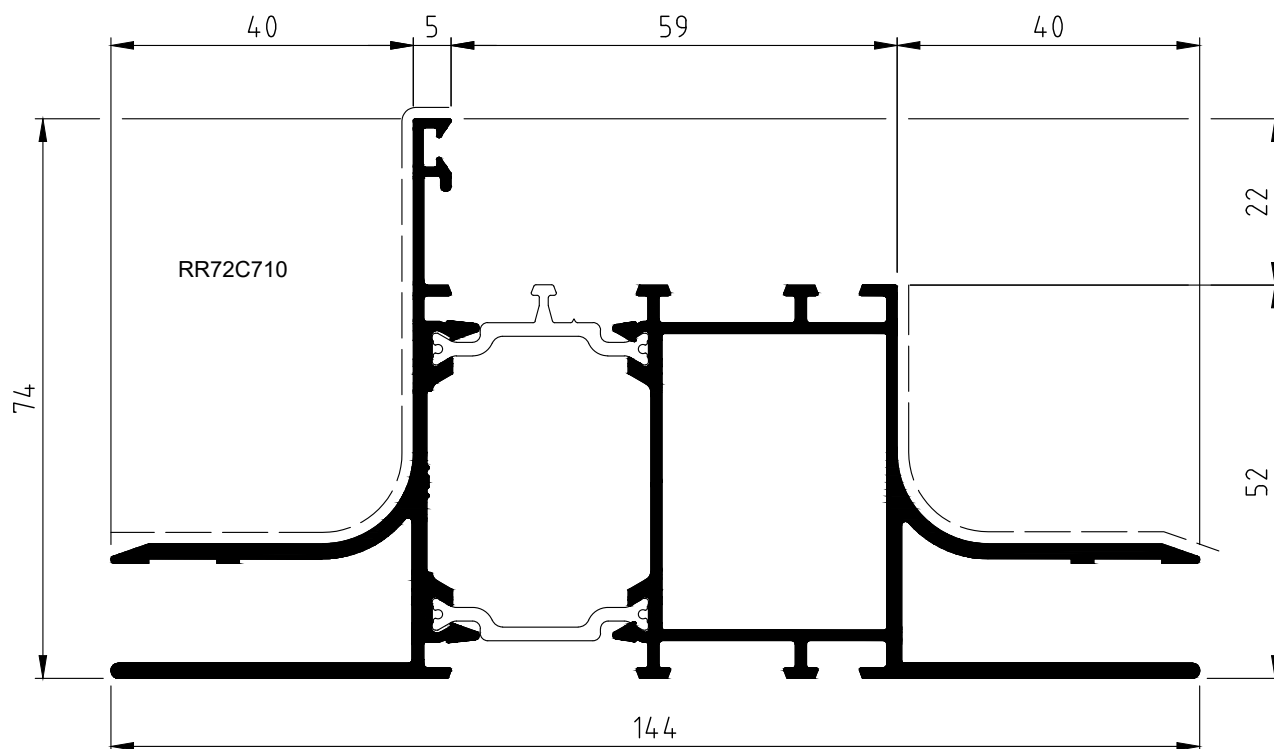
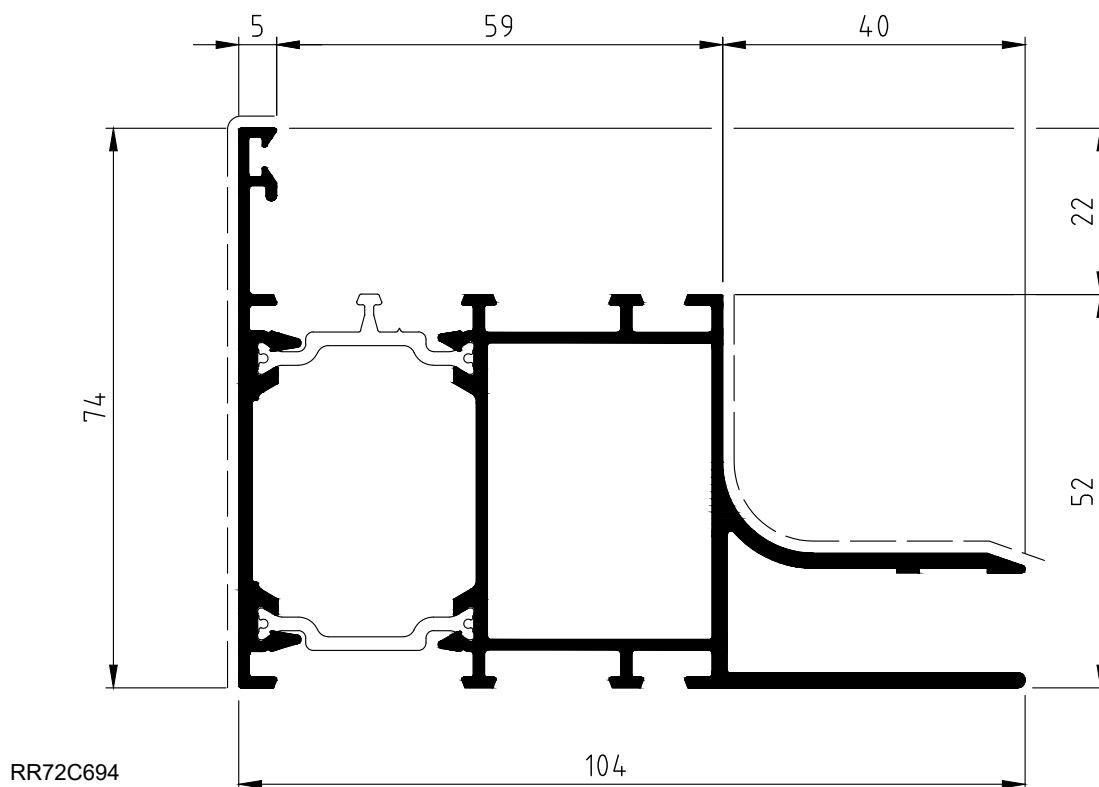

TELAI SPECIALI
SPECIAL FRAMES

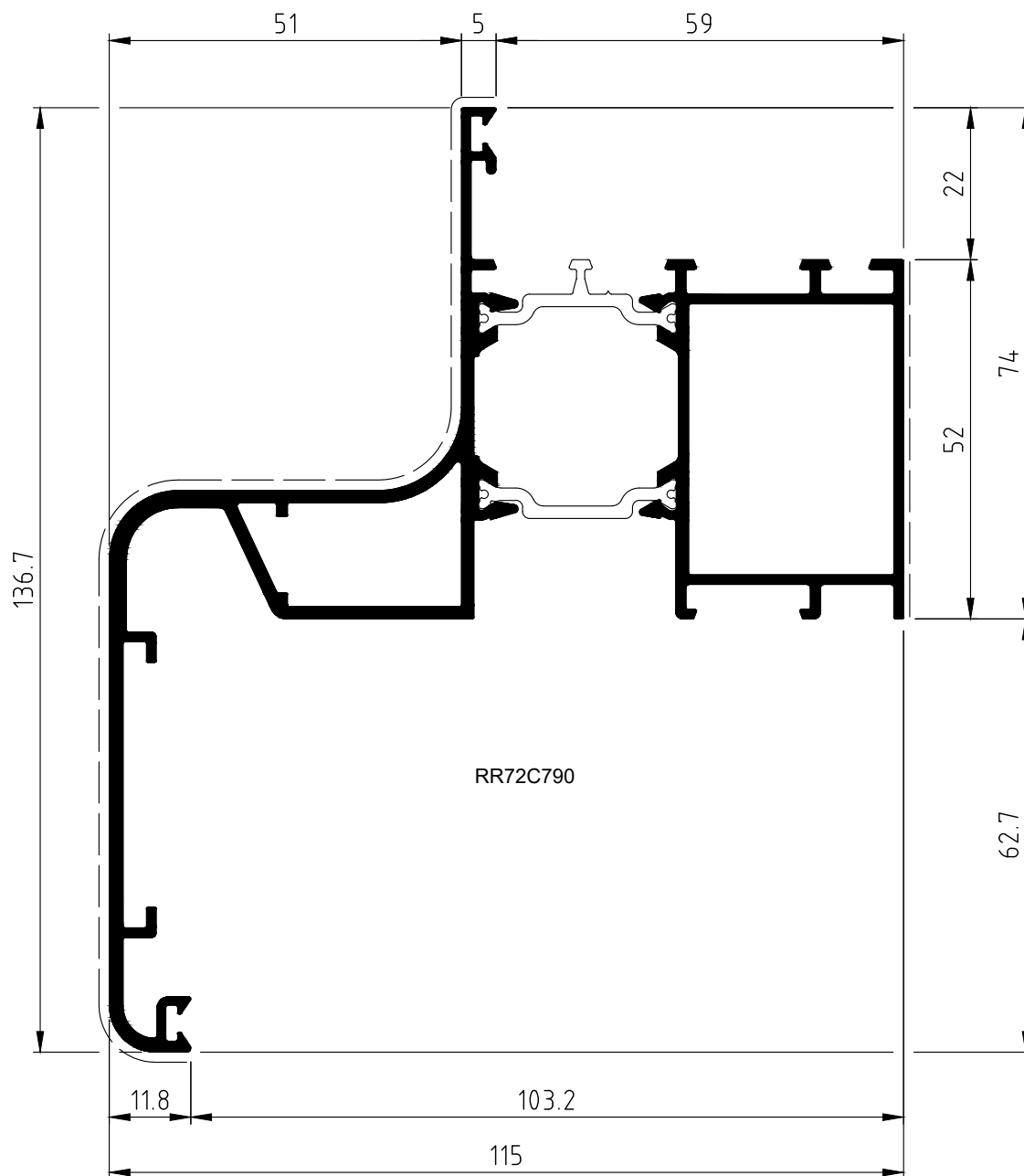

TELAJ SPECIALI
SPECIAL FRAMES

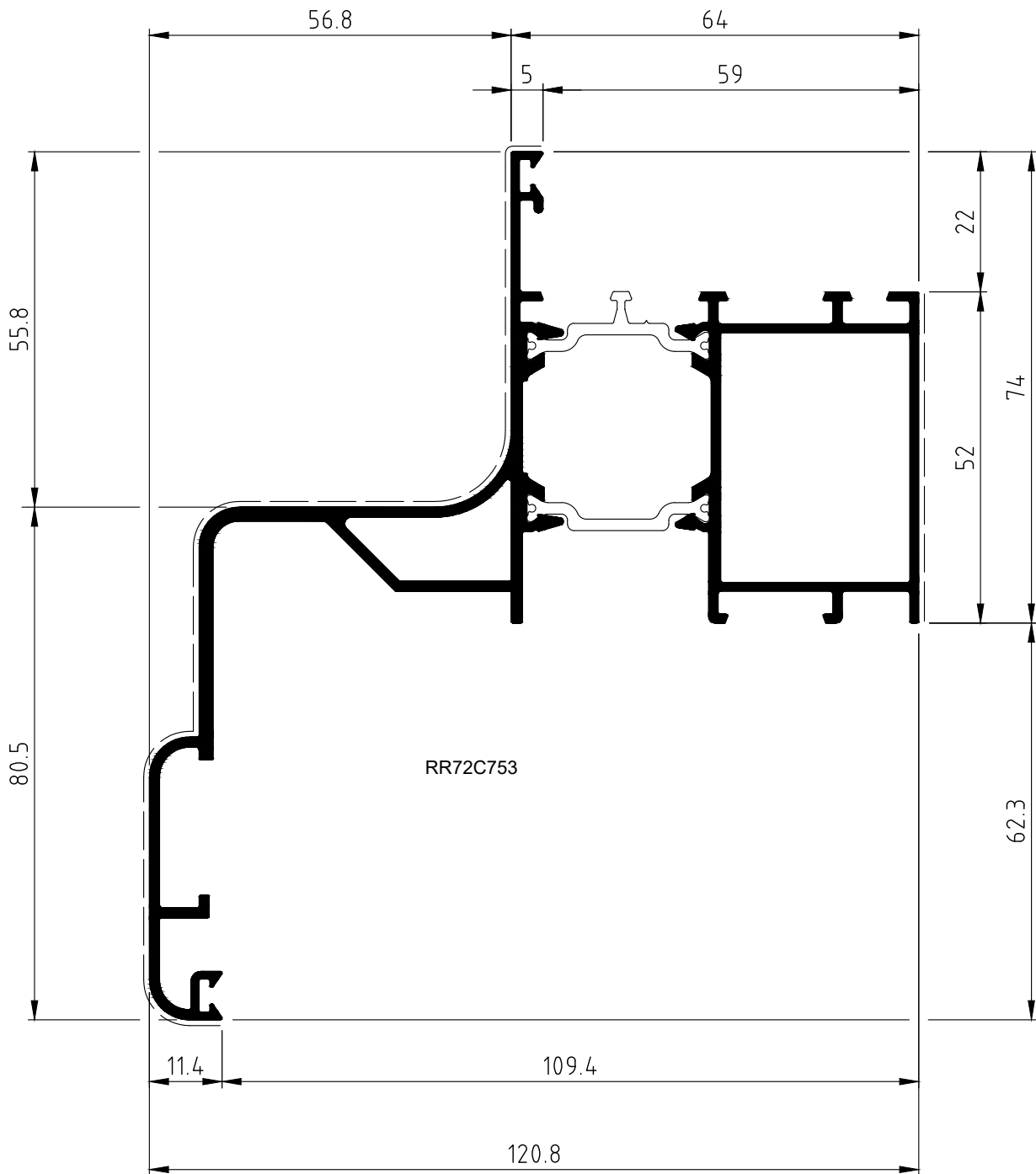

TELAJ SPECIALI
SPECIAL FRAMES

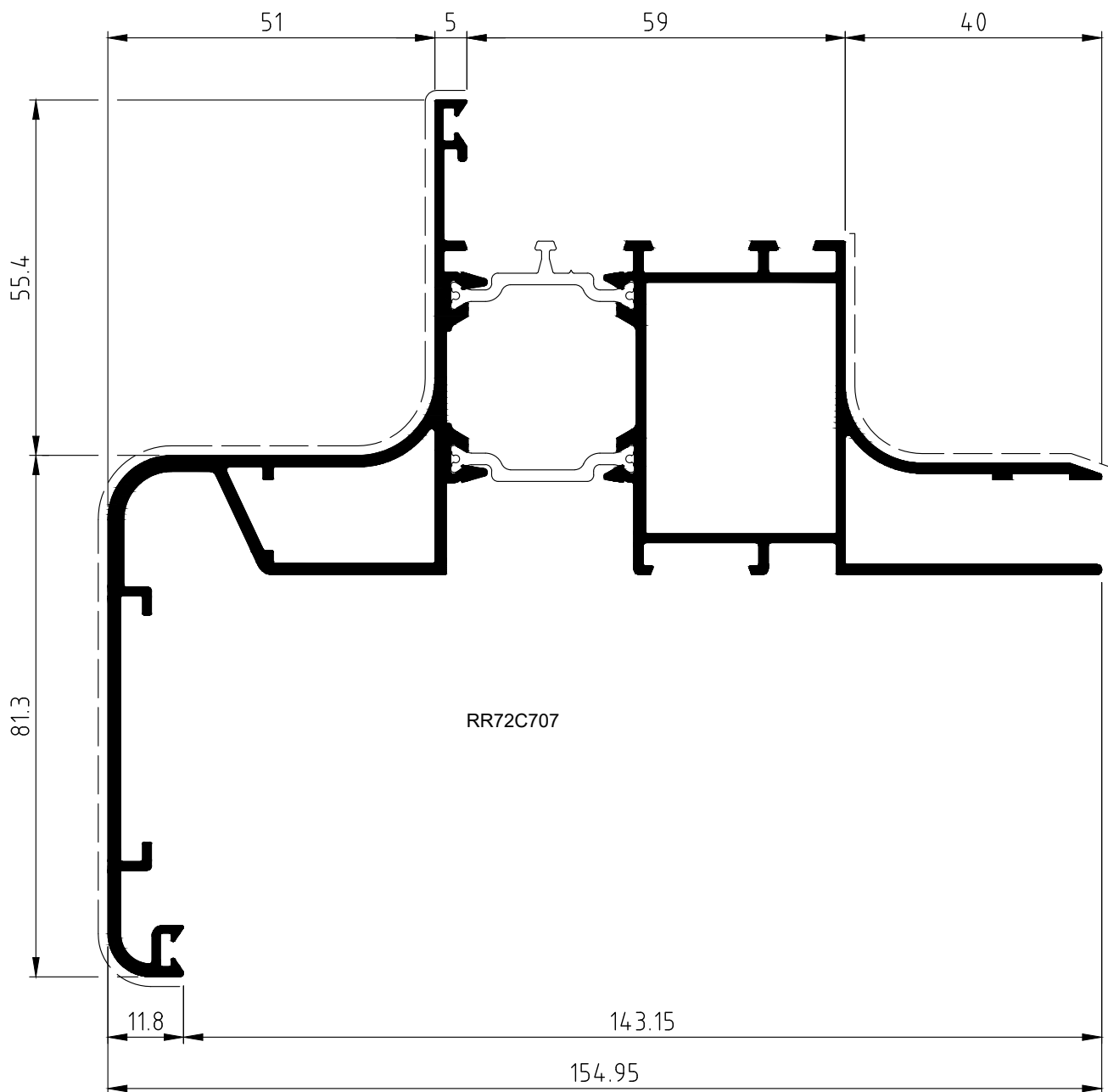

TELAI SPECIALI
SPECIAL FRAMES

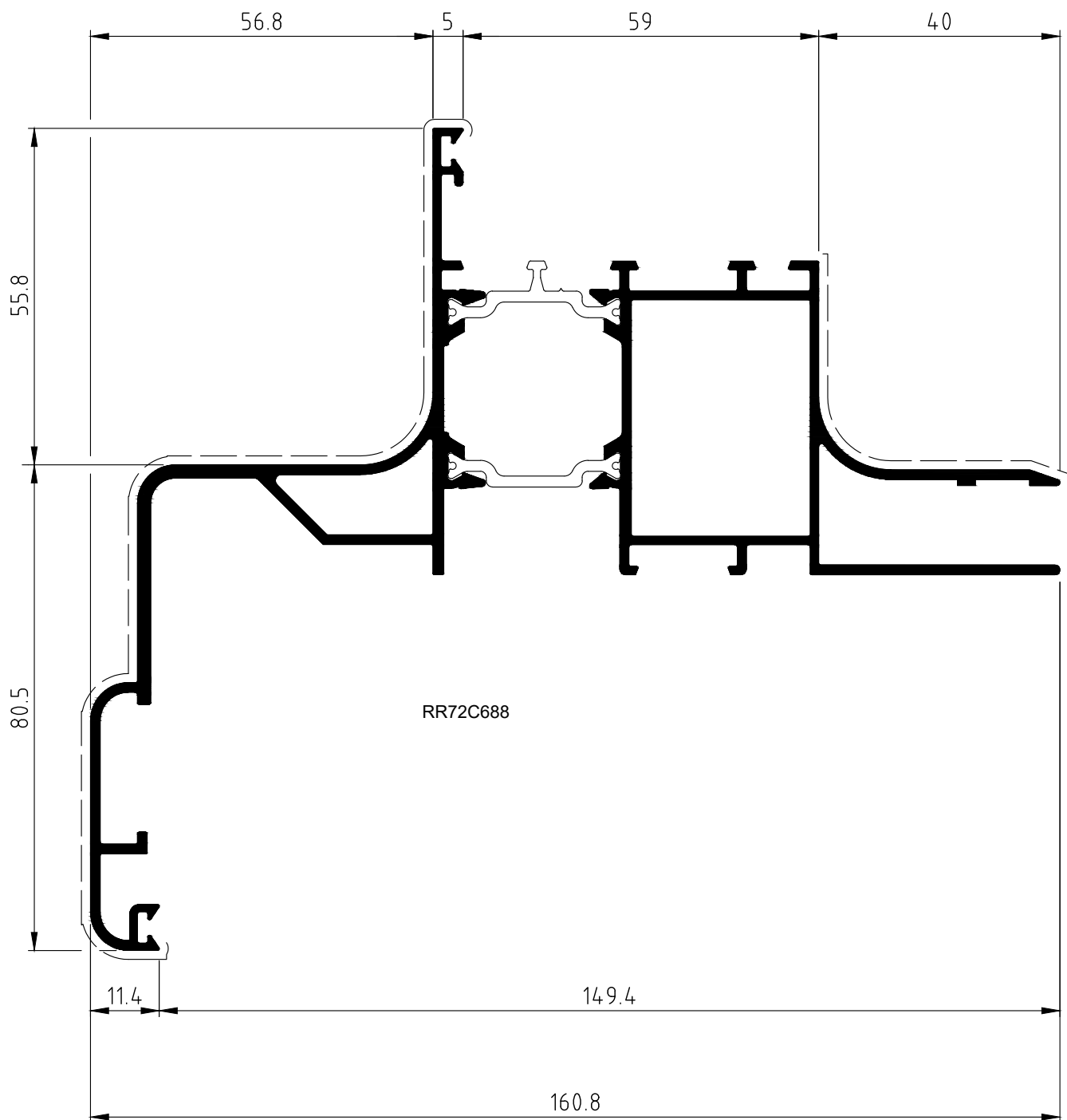

TELAJ SPECIALI
SPECIAL FRAMES

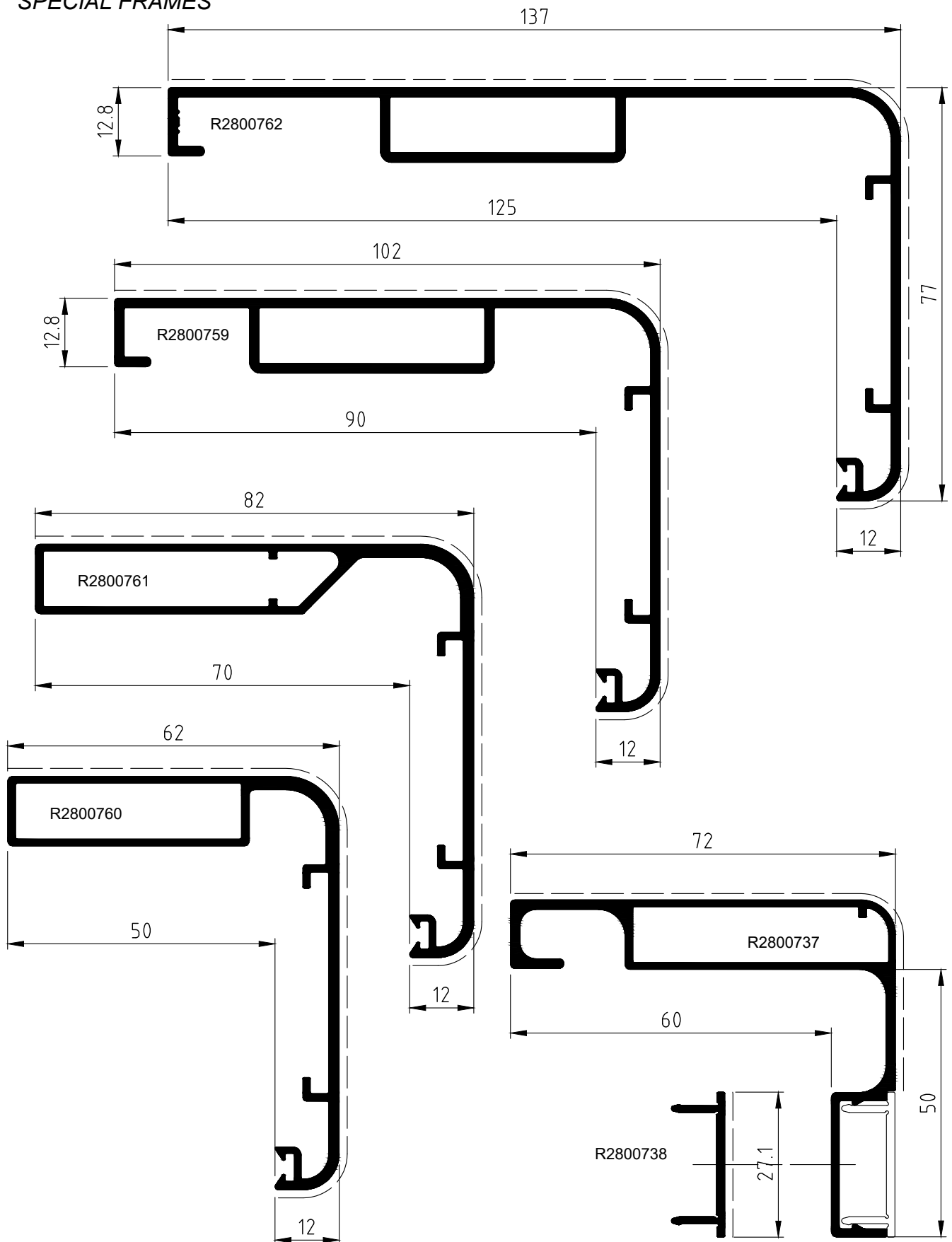

TELAI SPECIALI
SPECIAL FRAMES

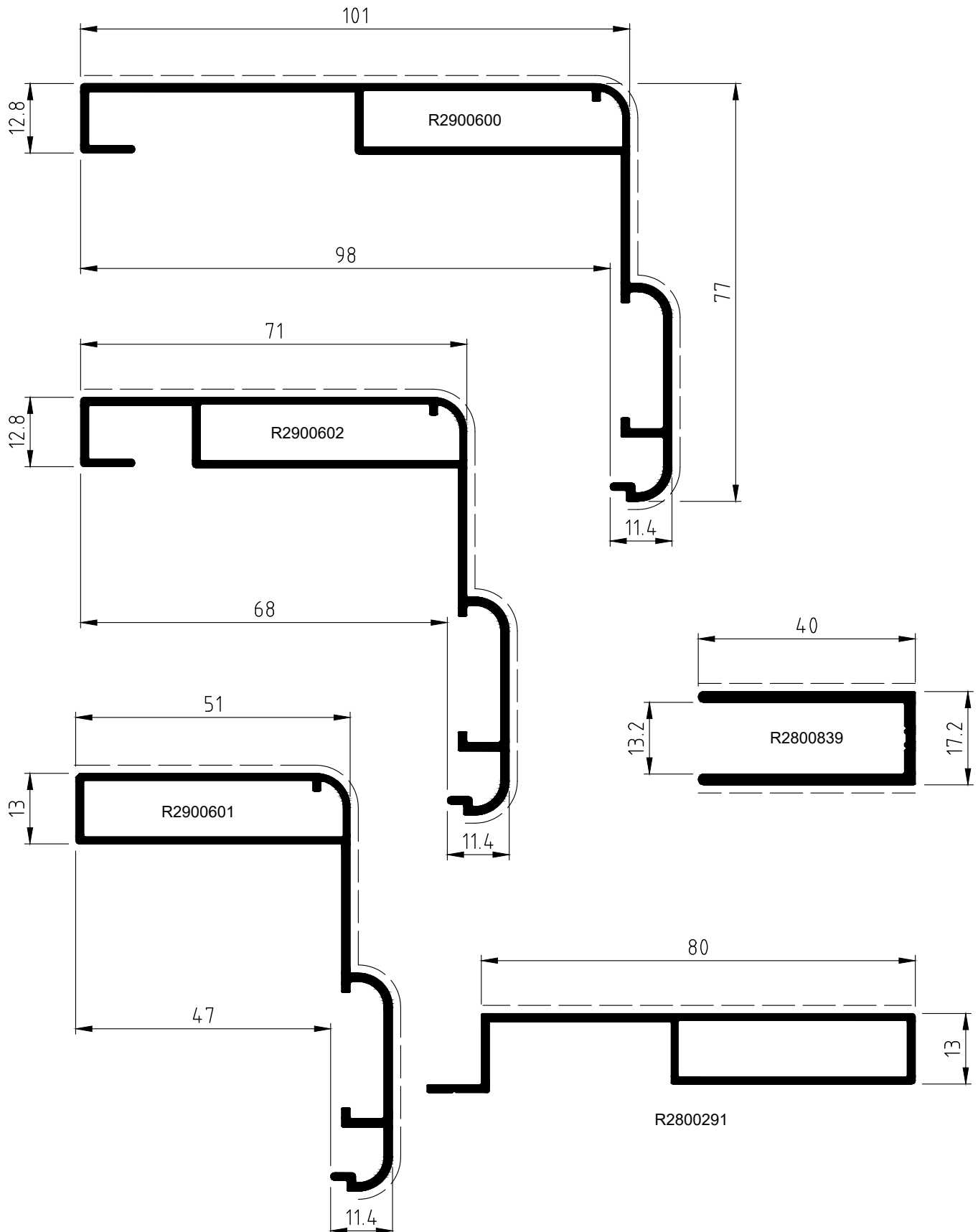

TELAIO PER ABBINAMENTO CON FACCIATA
FRAME TO COMBINE WITH CURTAIN WALL

RR72C726

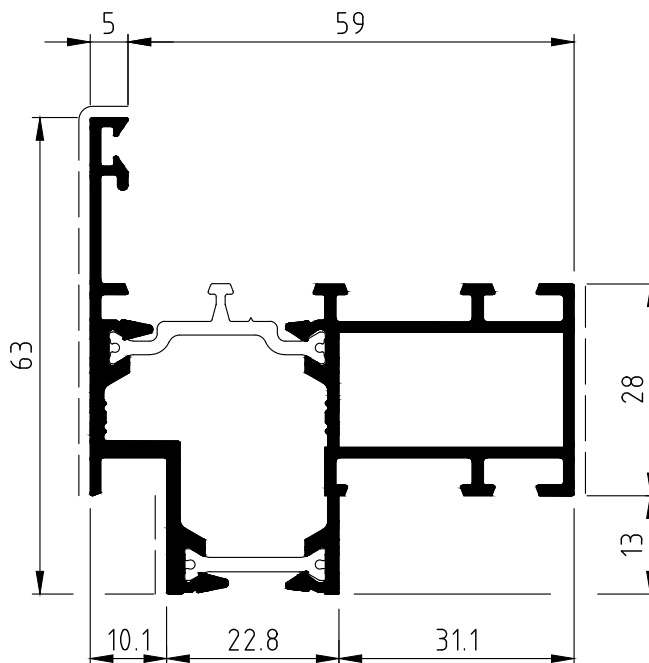

FASCE - ZOCCOLI
BANDS - SKIRTING BOARDS

RR72C721

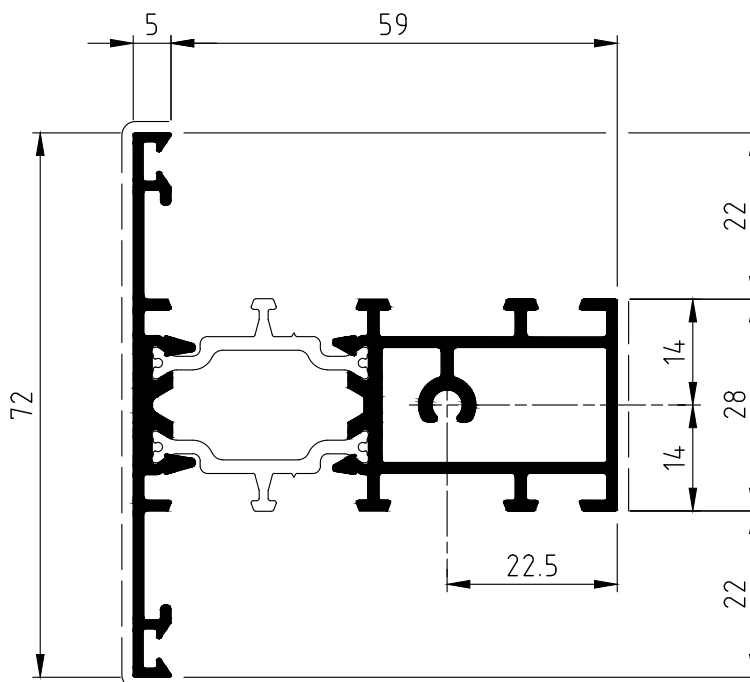

RR72C722

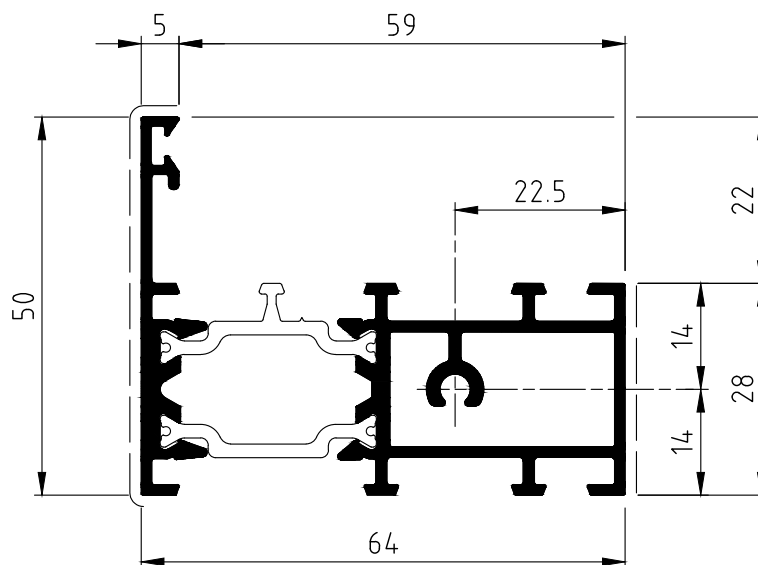

FASCE - ZOCCOLI
BANDS - SKIRTING BOARDS

RR72C669

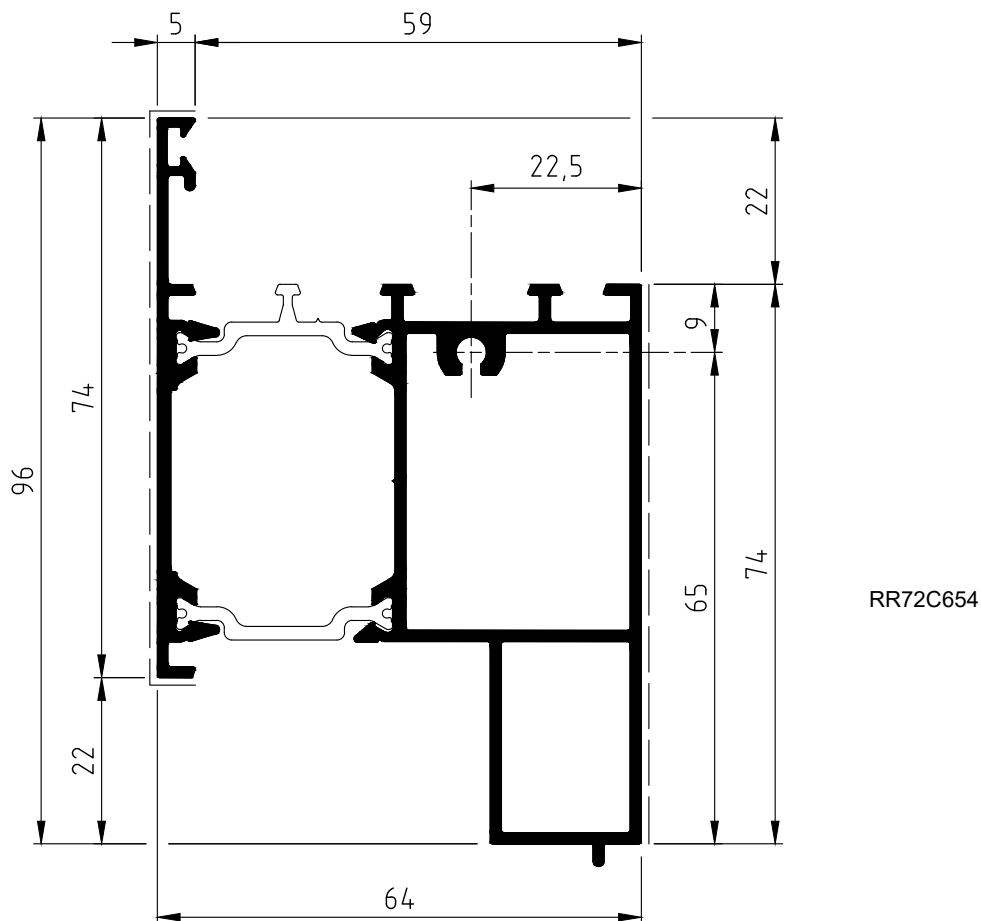
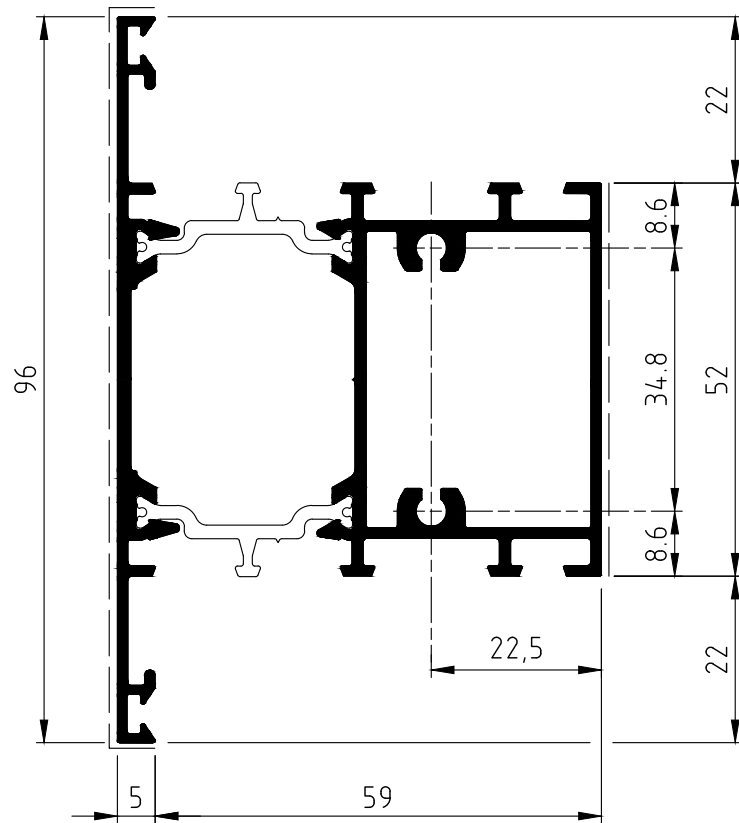

RR72C654

FASCE - ZOCCOLI
BANDS - SKIRTING BOARDS
PER ANTE PIANE

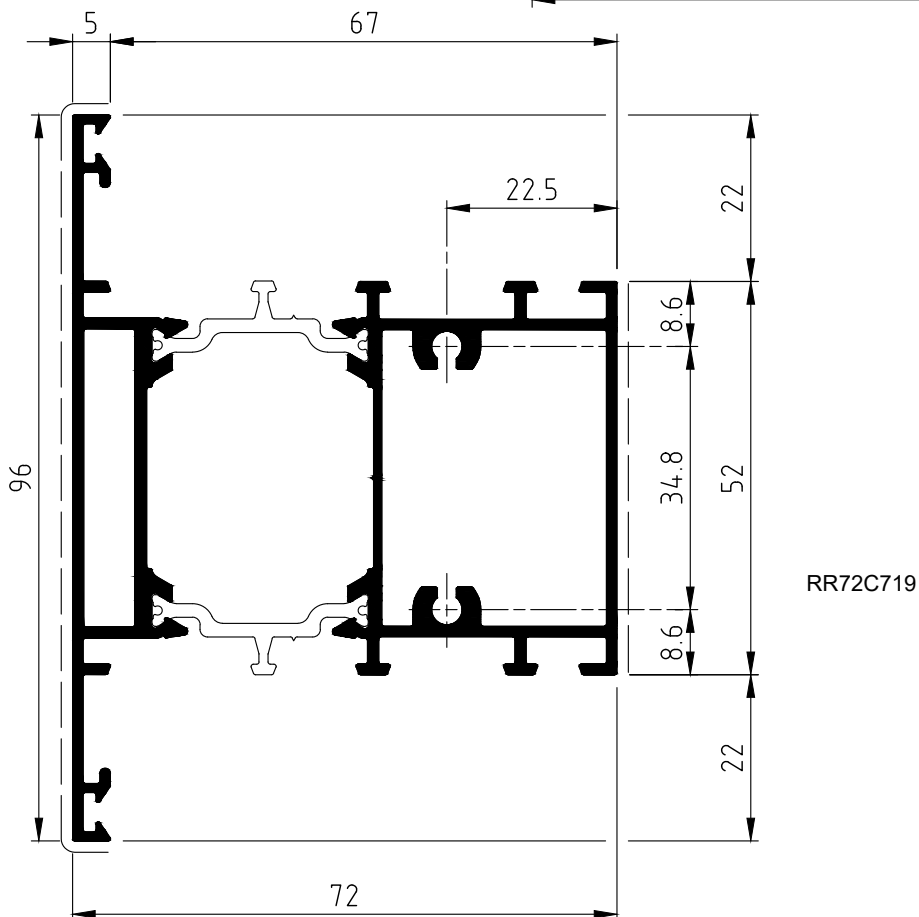
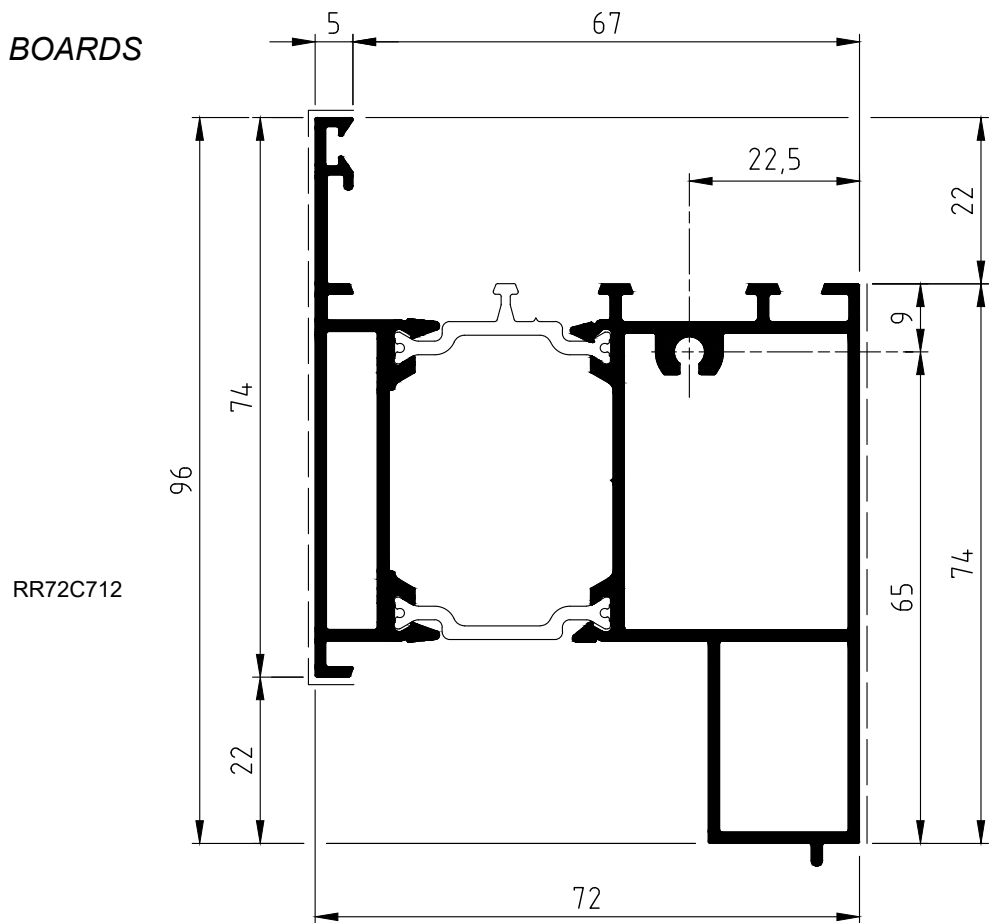

FASCE - ZOCOLI
BANDS - SKIRTING BOARDS

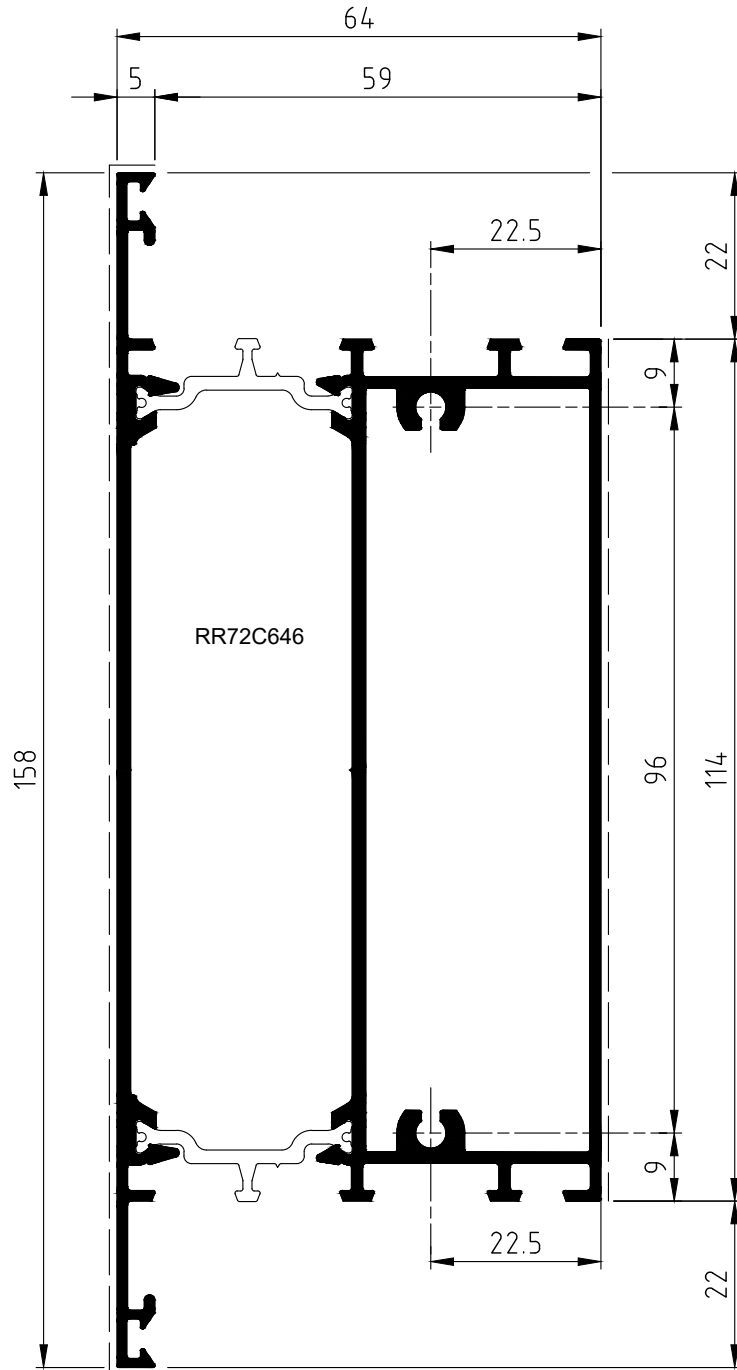

FASCE - ZOCCOLI
BANDS - SKIRTING BOARDS

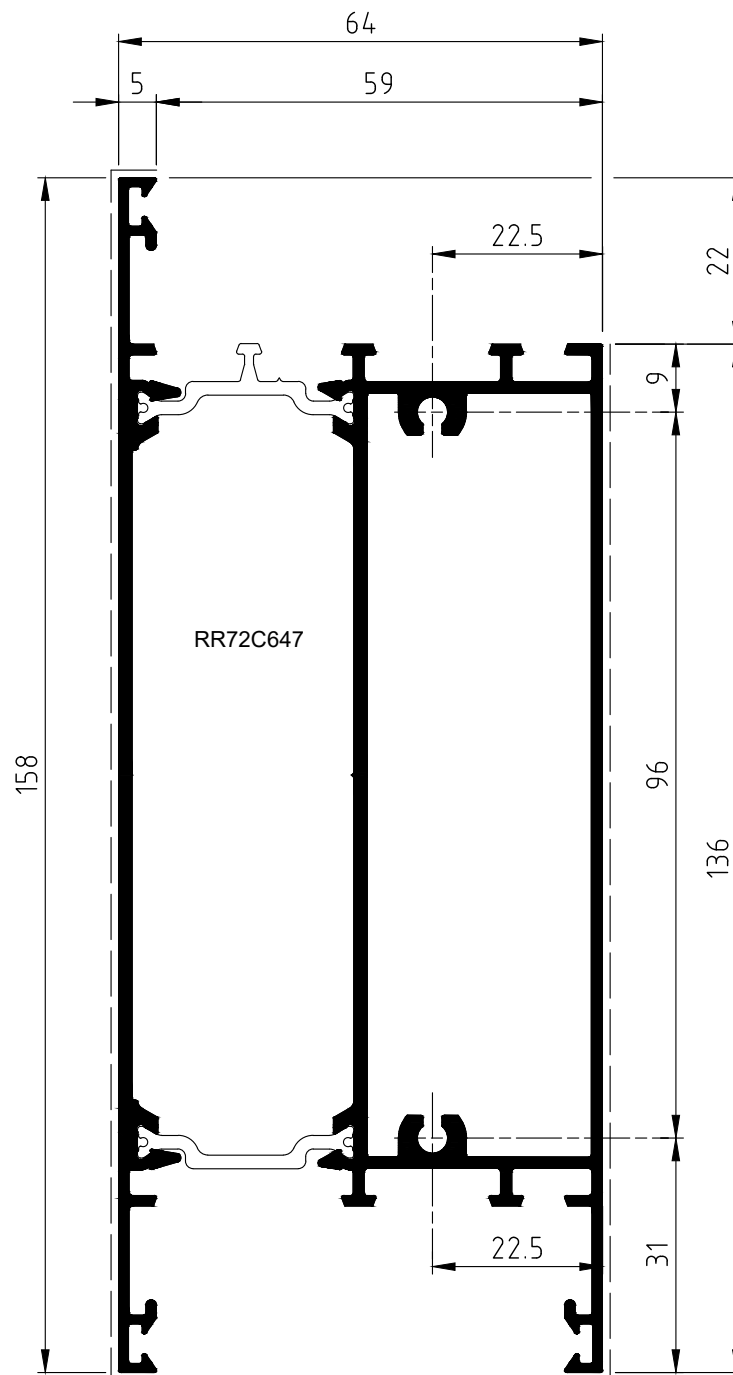

PILASTRINI
NEWEL POSTS

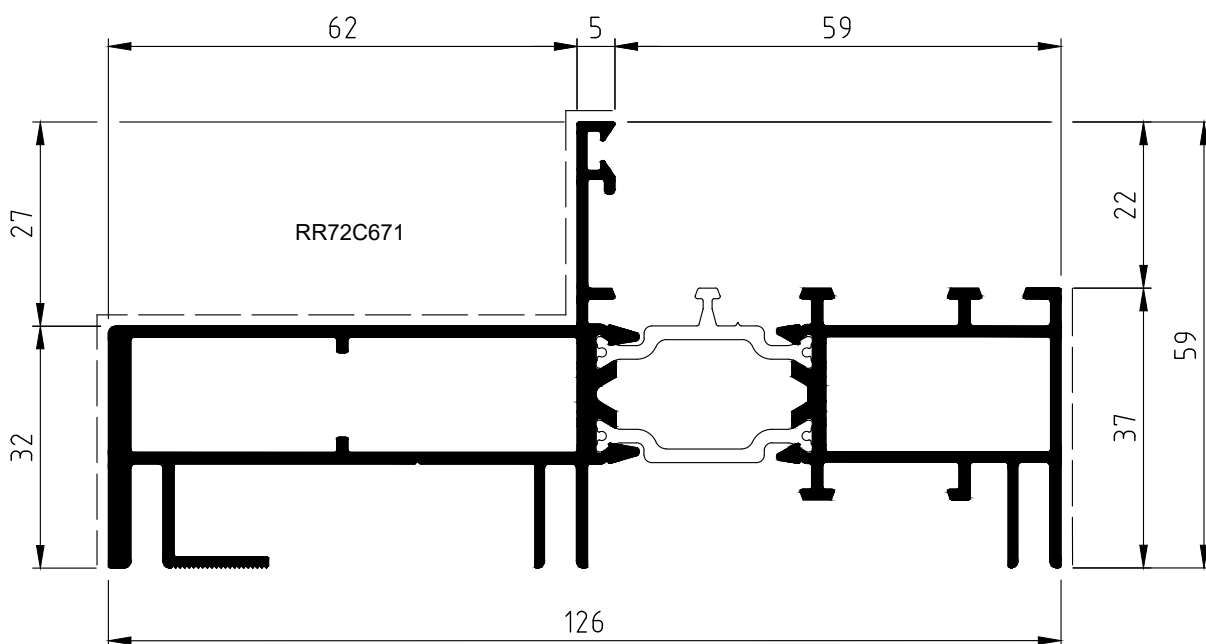
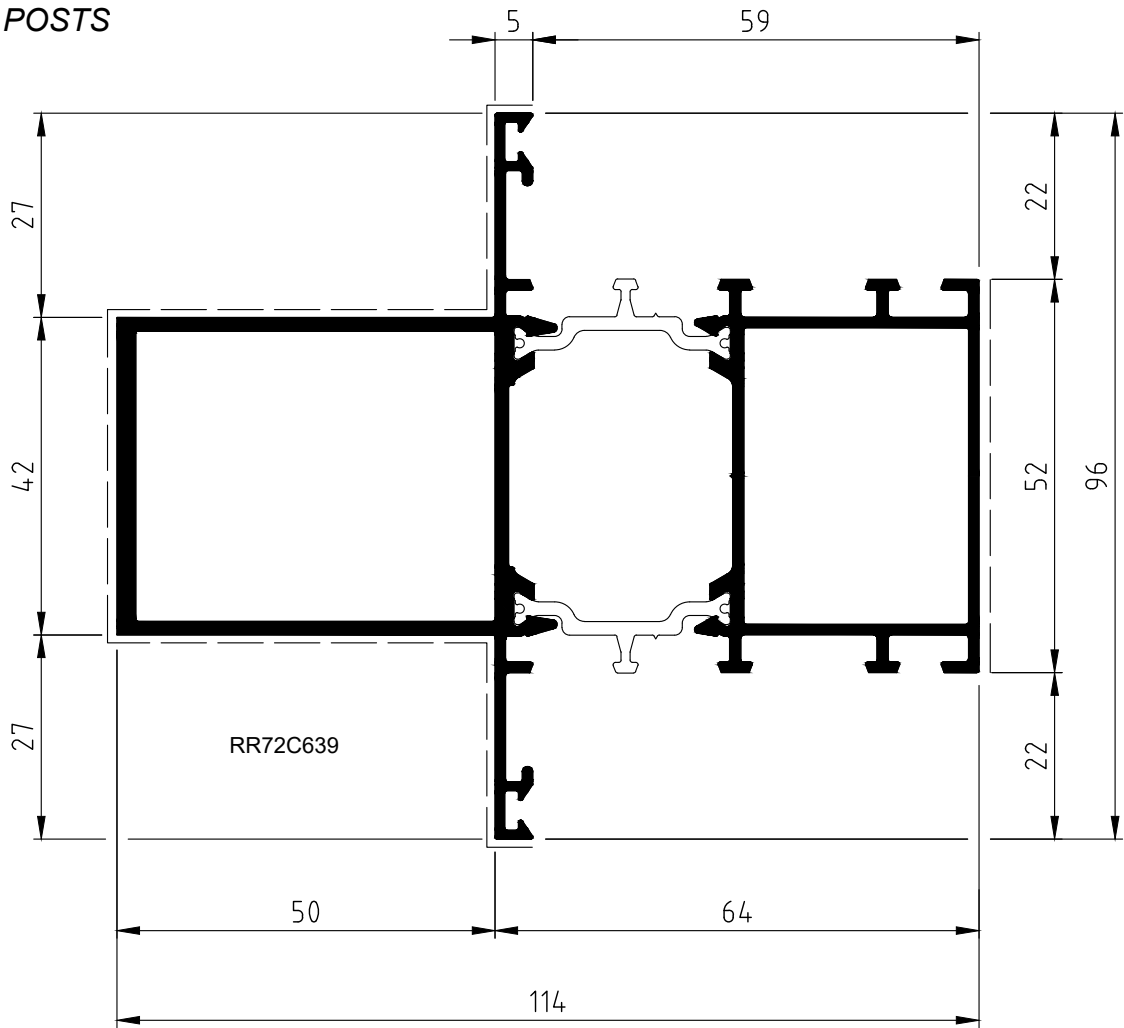

MONOBLOCCO
MONOBLOCK

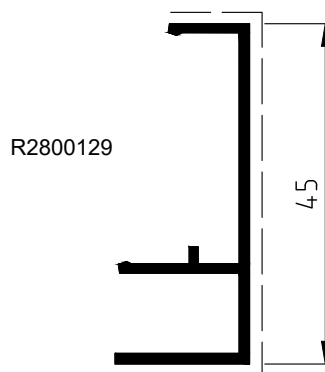
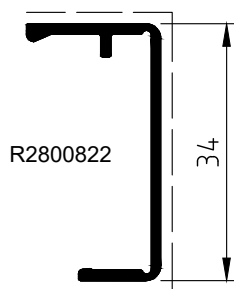
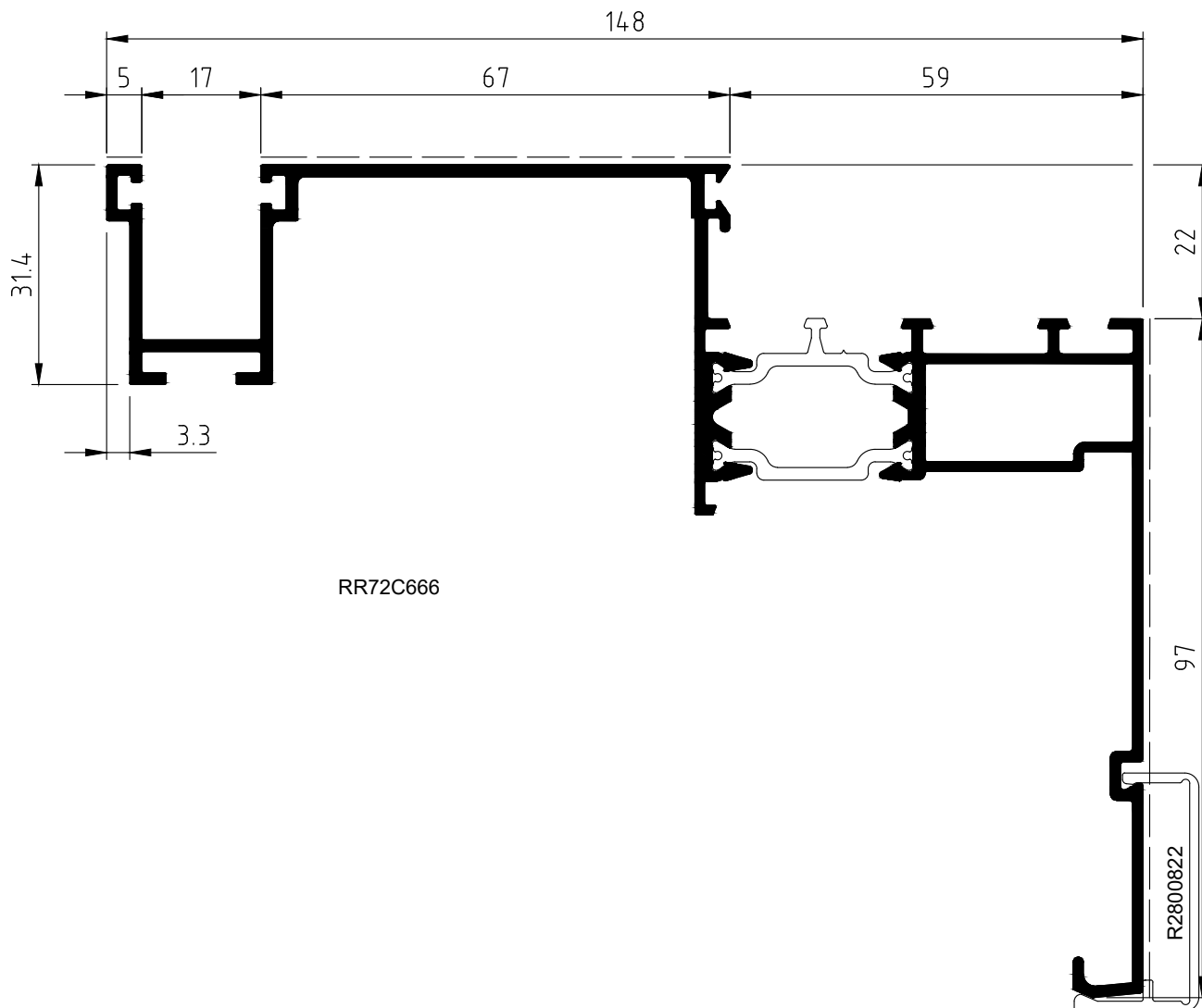

MONOBLOCCO
MONOBLOCK

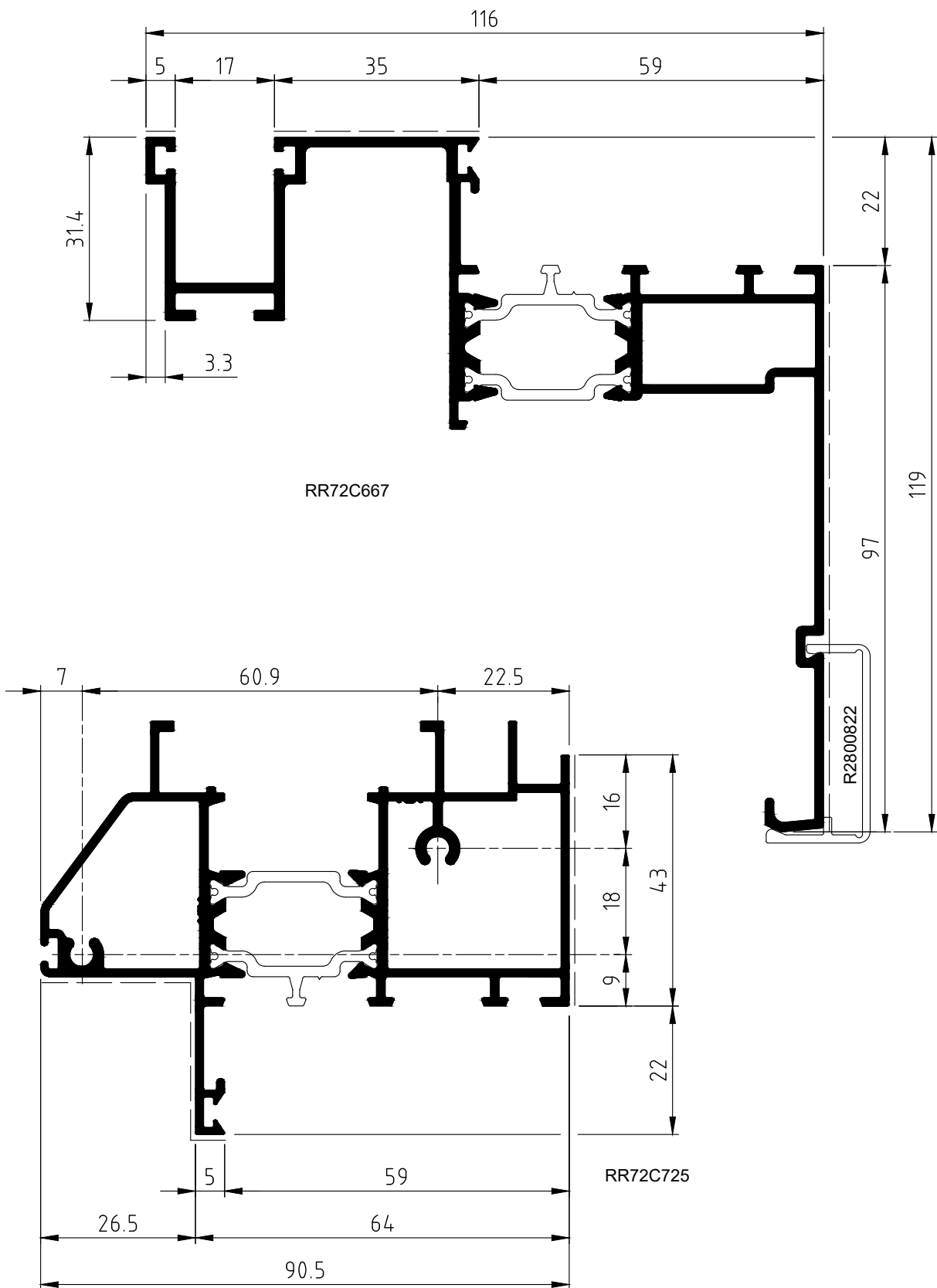

MONOBLOCCO
MONOBLOCK

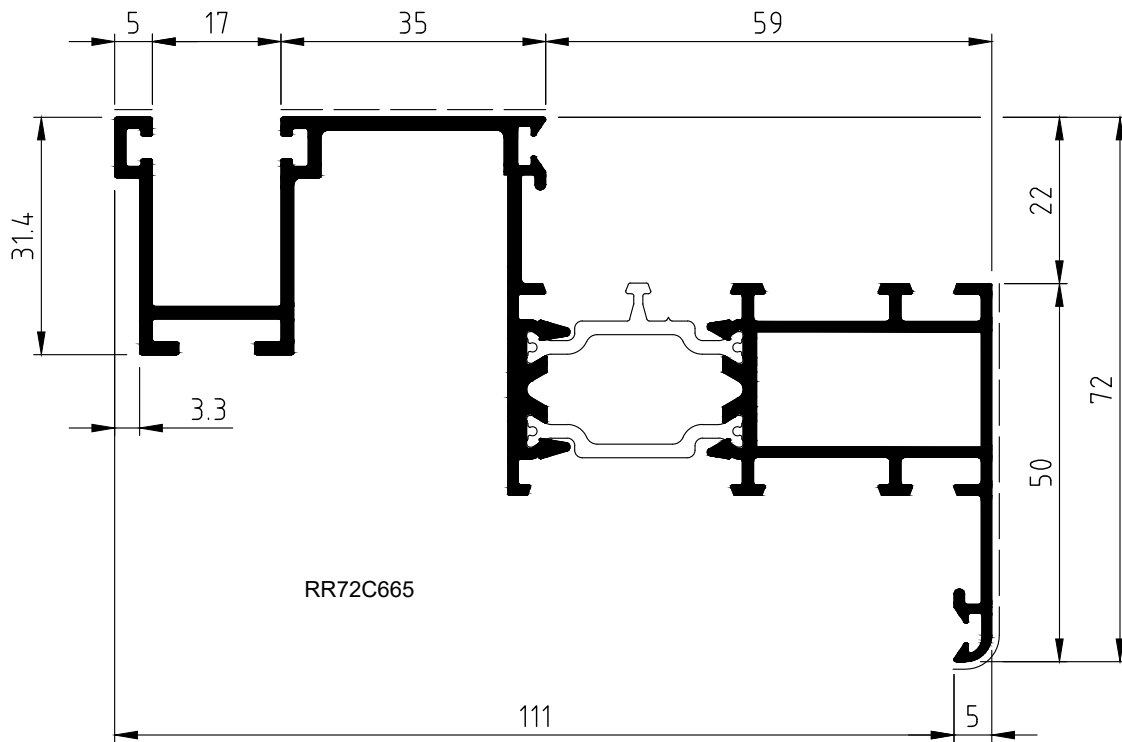
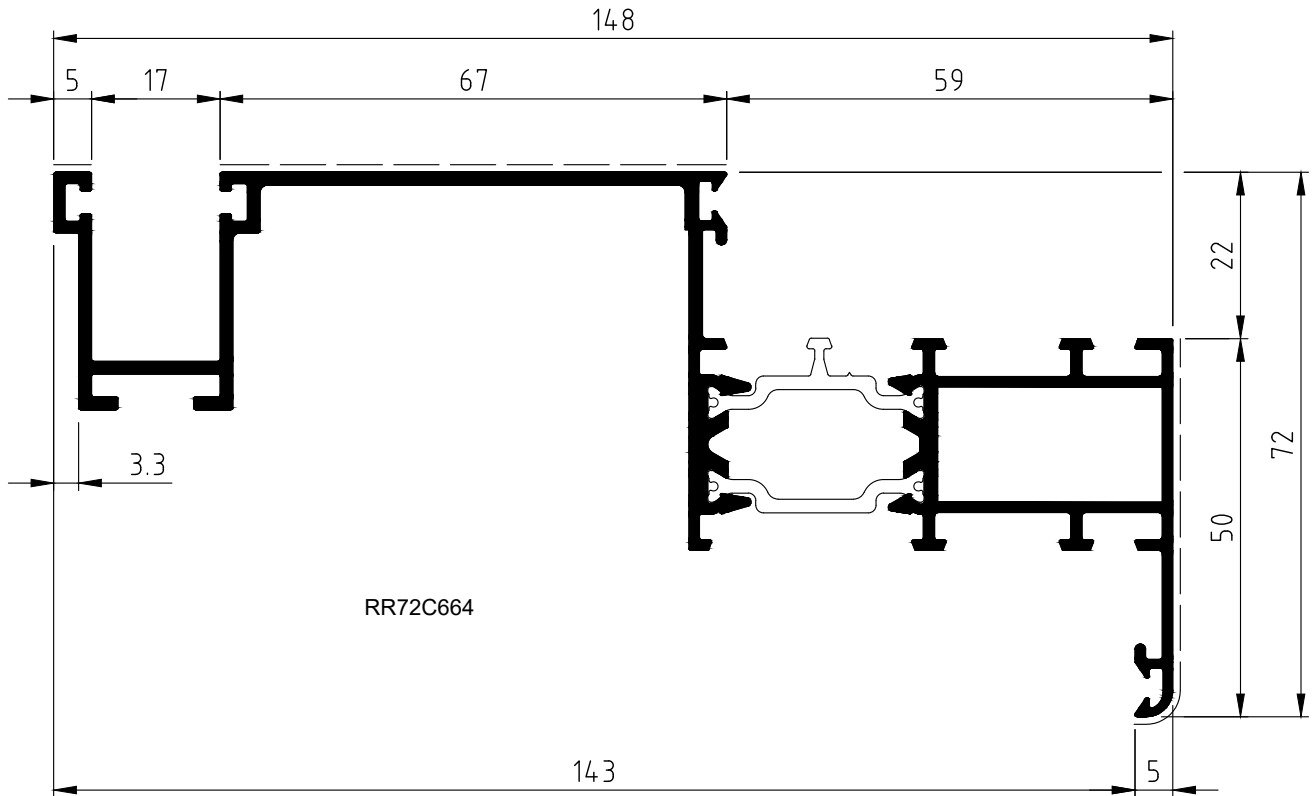

MONOBLOCCO
MONOBLOCK

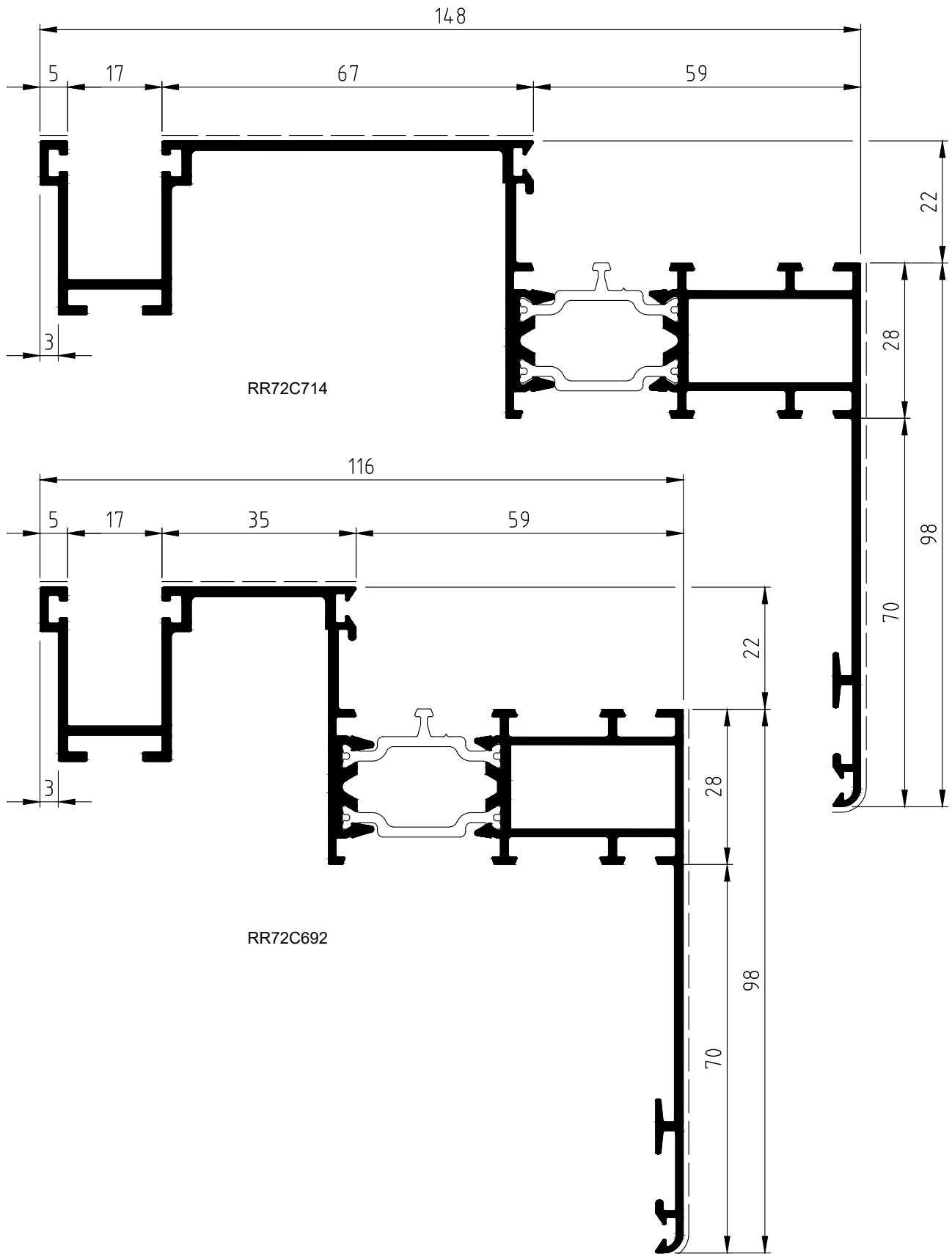

MONOBLOCCO
MONOBLOCK

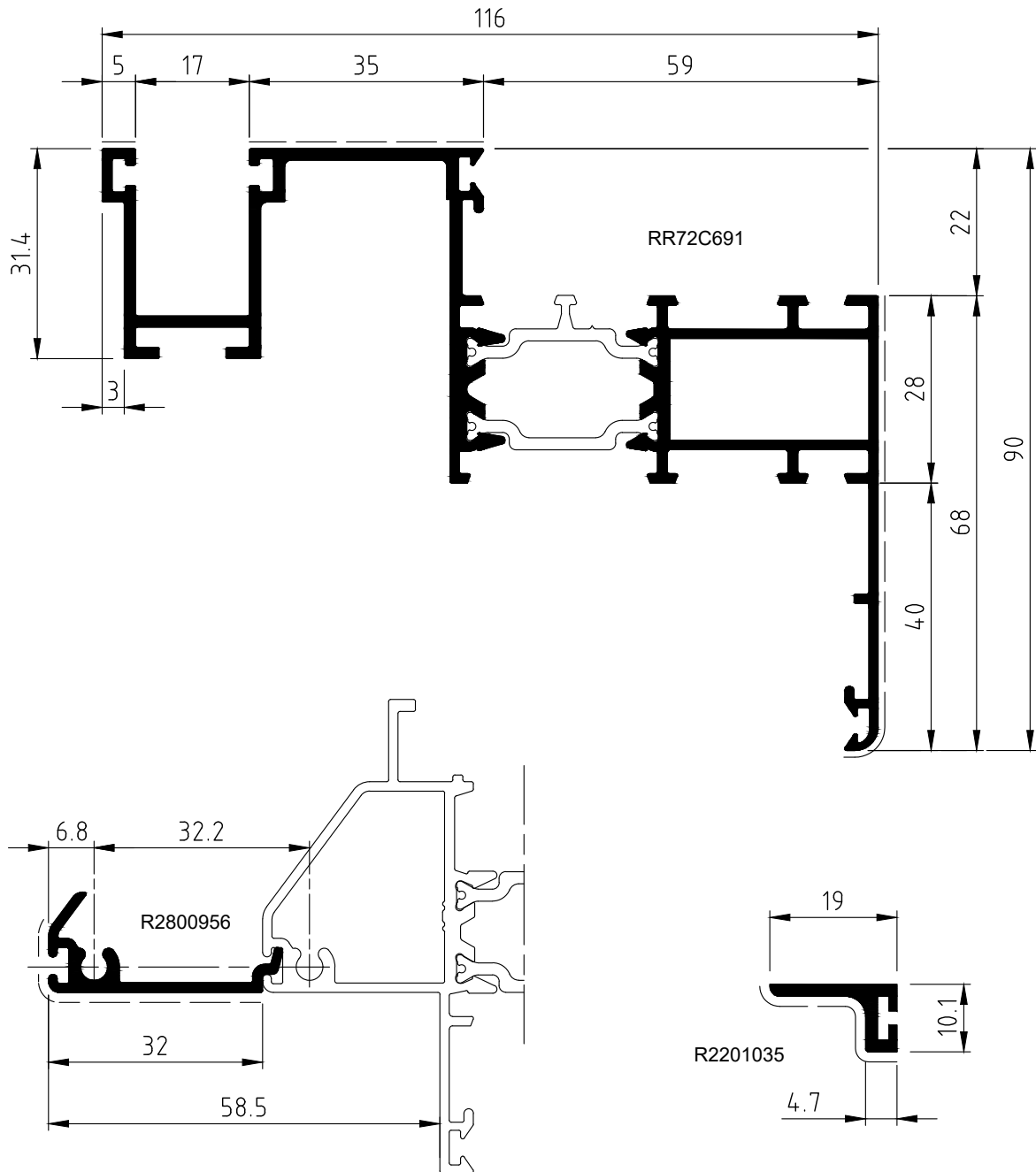

MONOBLOCCO
MONOBLOCK

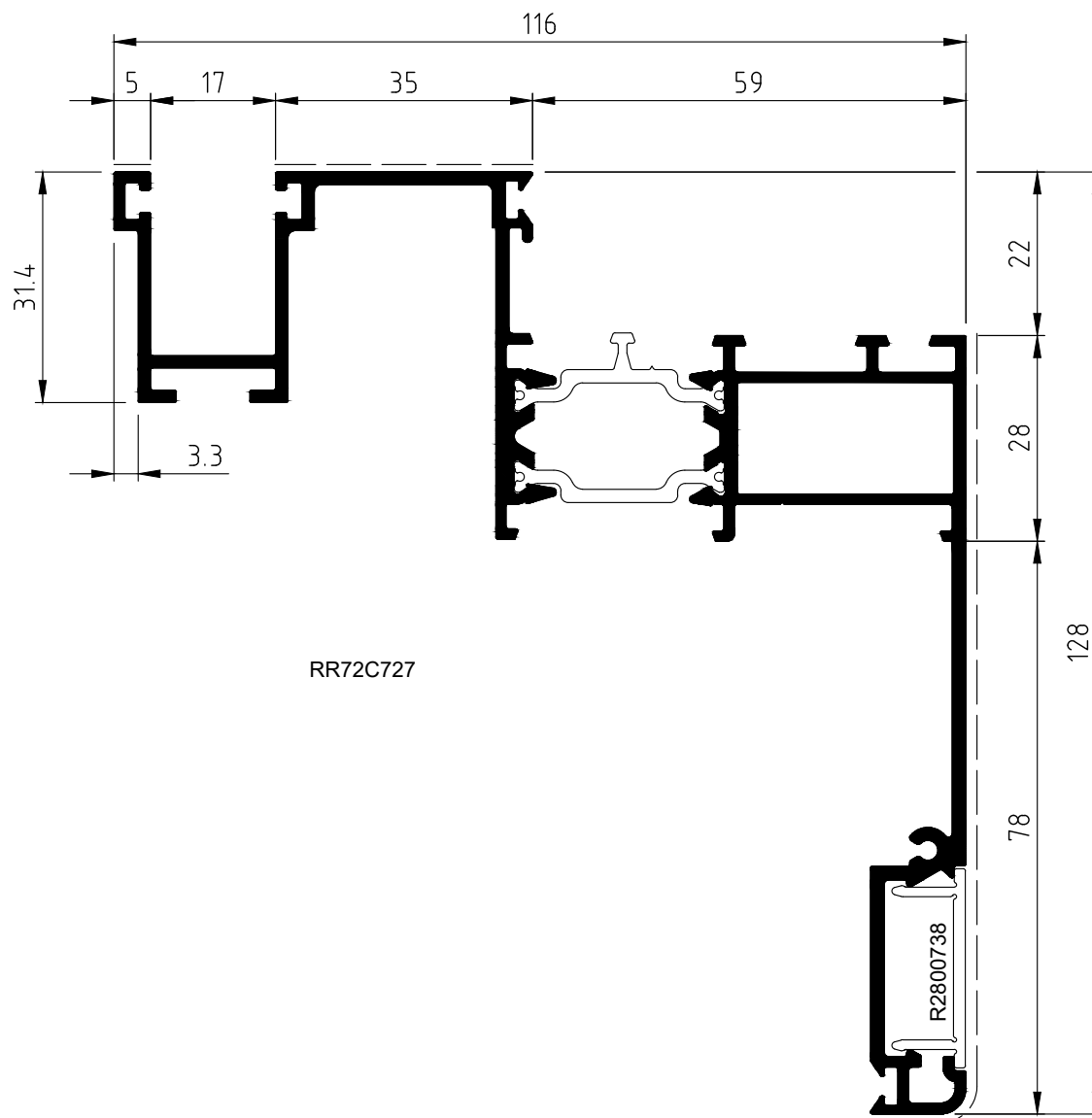

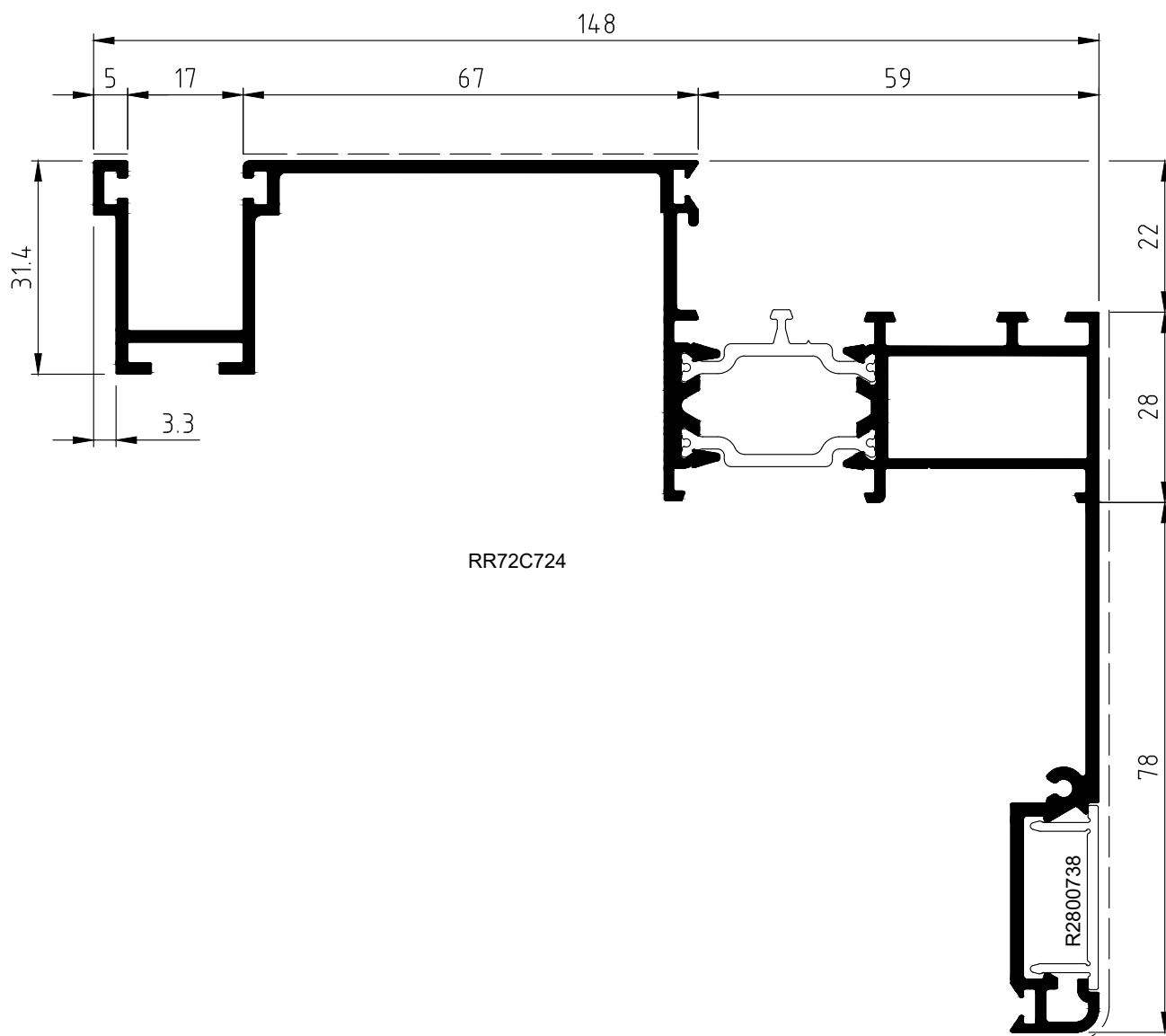

MONOBLOCCO
MONOBLOCK

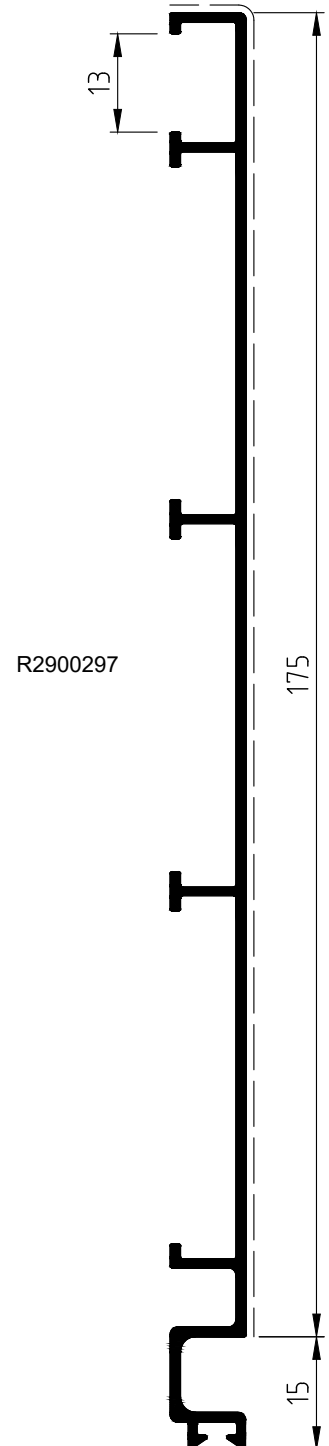
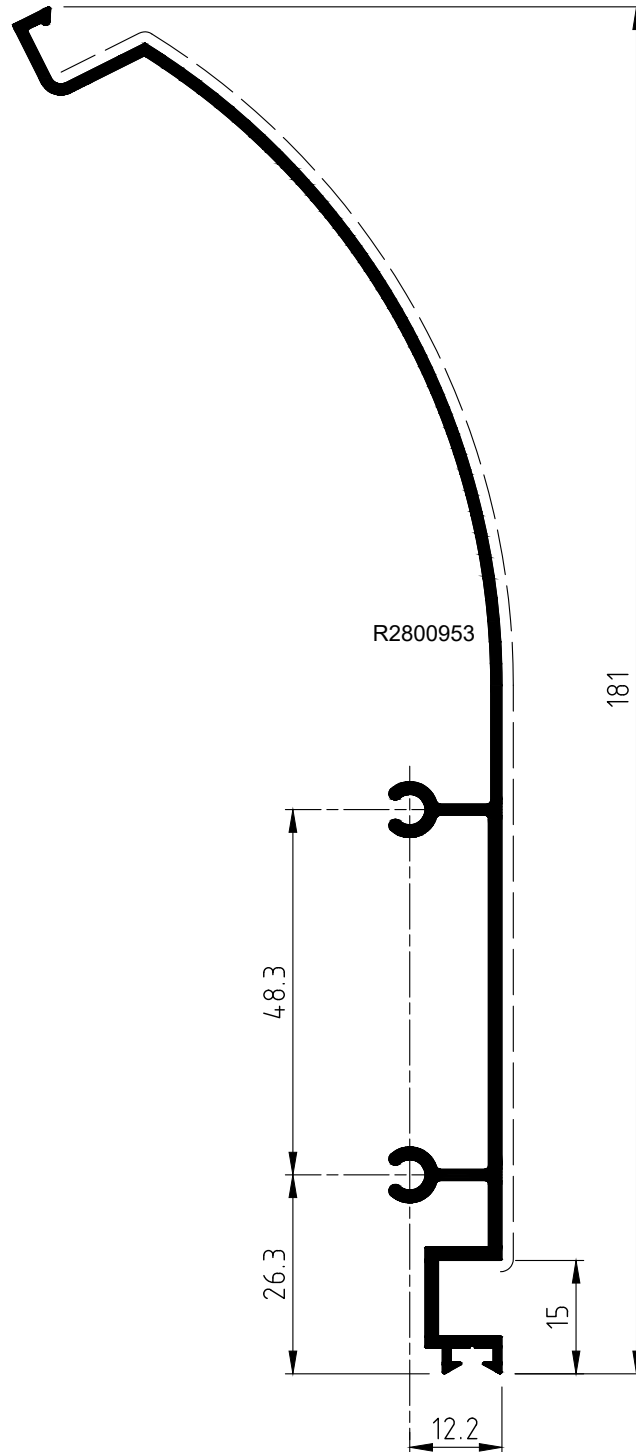
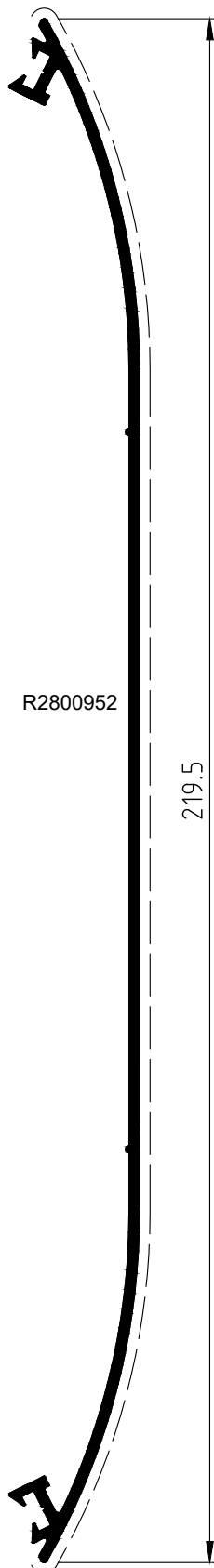

PROFILATI PER SOGLIA
FRAME SECTIONS

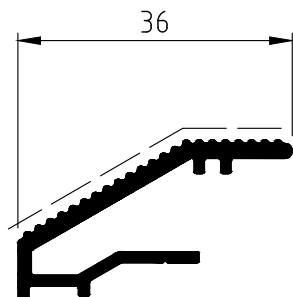

R2800729

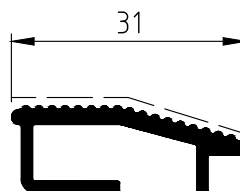

R2800728

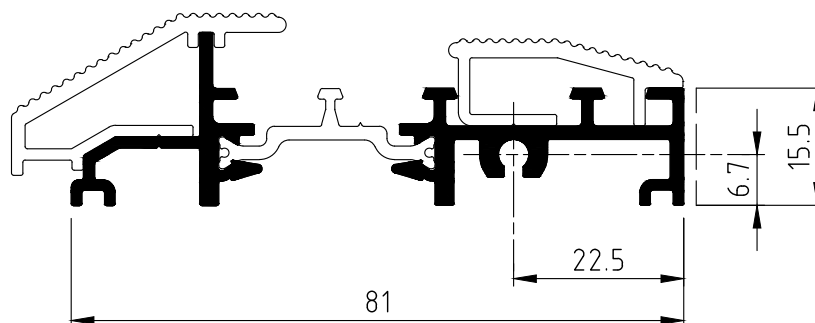

RR72C696

CONTROTELAI
COUNTER FRAMES

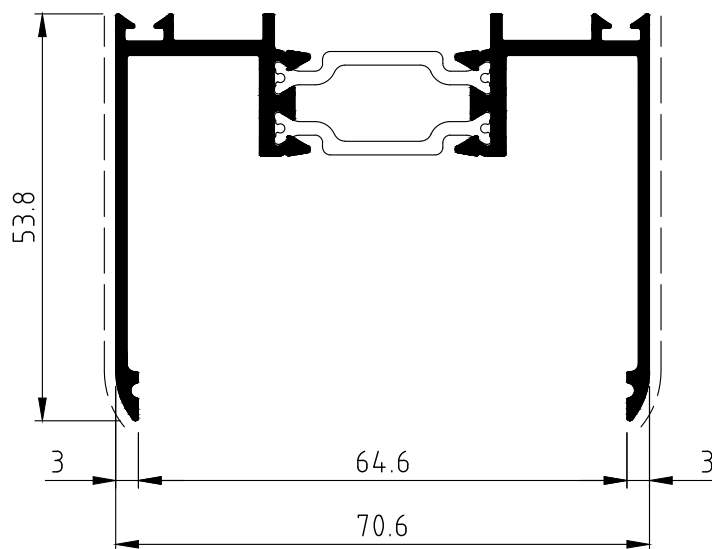

RR72C128

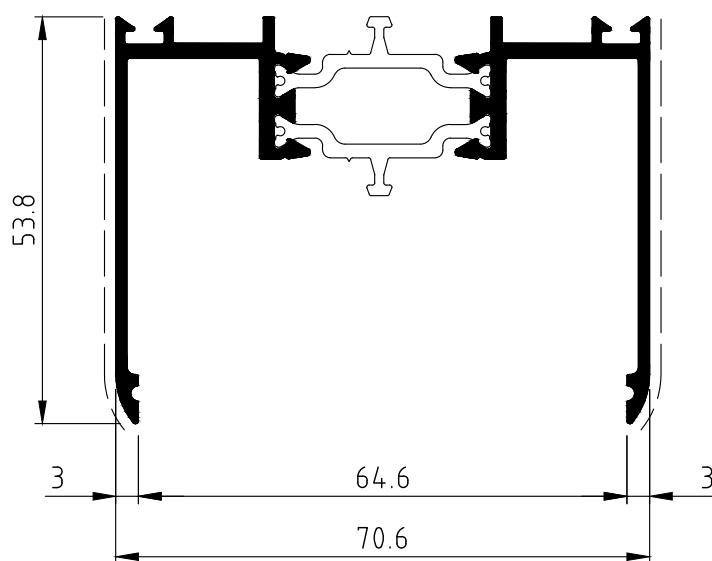

RR72C711

CONTROTELAI
COUNTER FRAMES

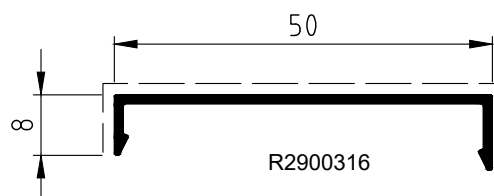
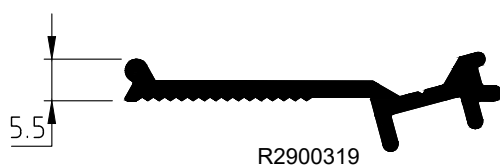
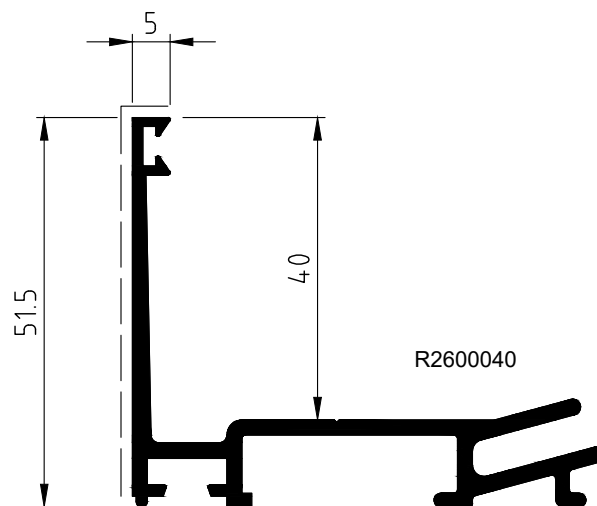

TELAI - APERTURA ESTERNA
FRAMES - OUTWARD OPENING

R2R72C59

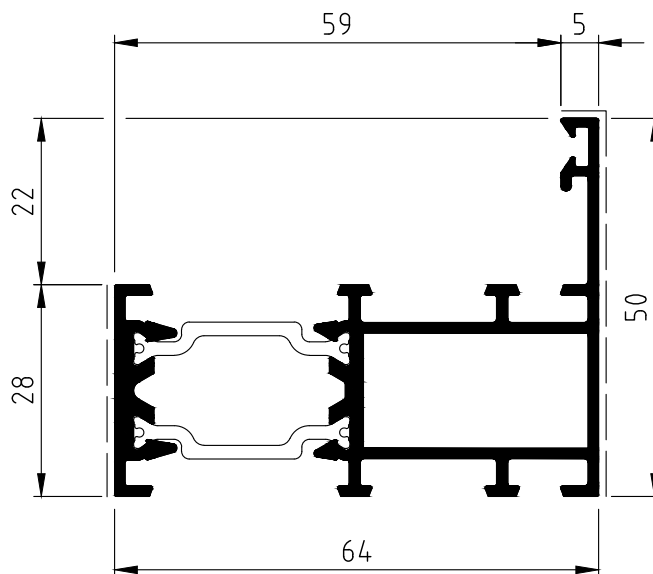

RR72C659

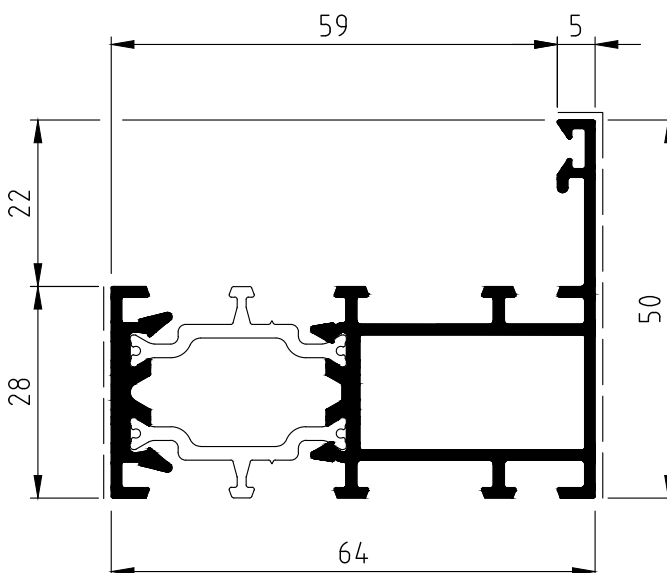

TELAI - APERTURA ESTERNA
FRAMES - OUTWARD OPENING

R2R72C60

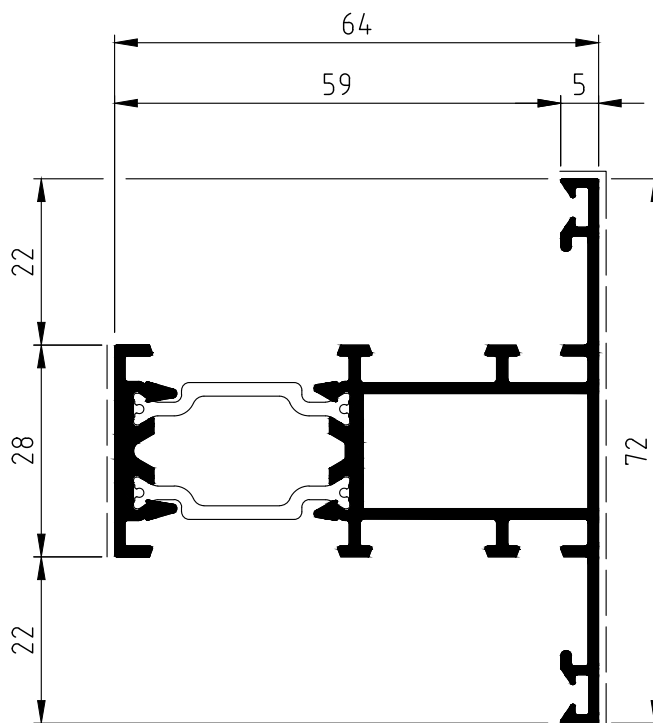

RR72C660

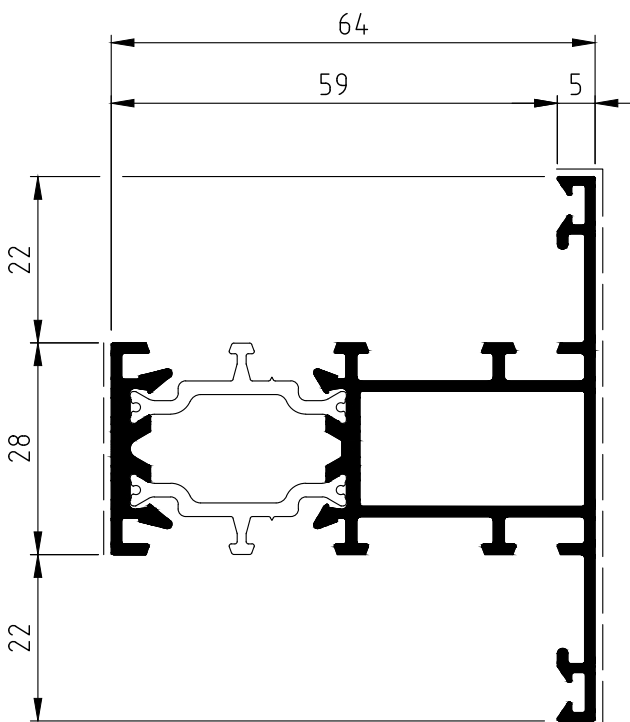

TELAI - APERTURA ESTERNA
FRAMES - OUTWARD OPENING

R2R72C61

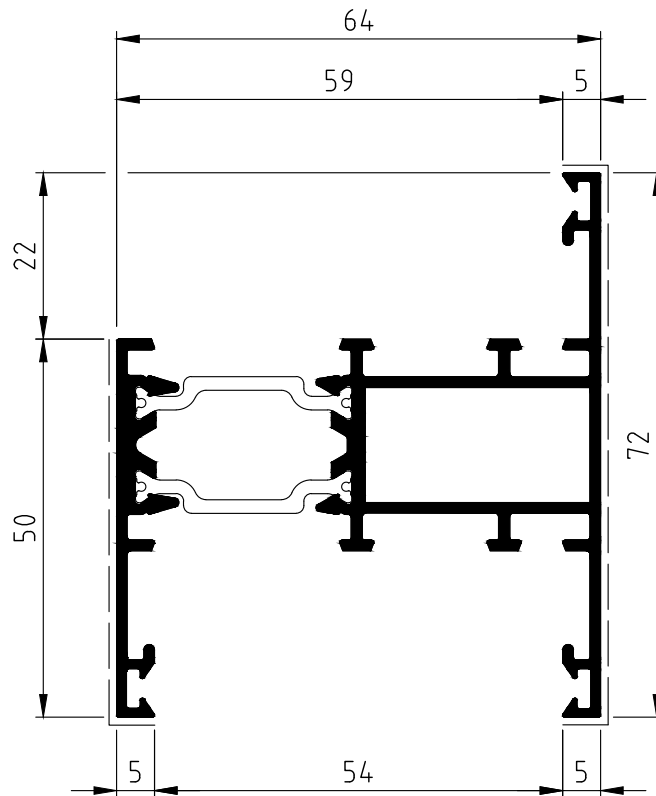

RR72C661

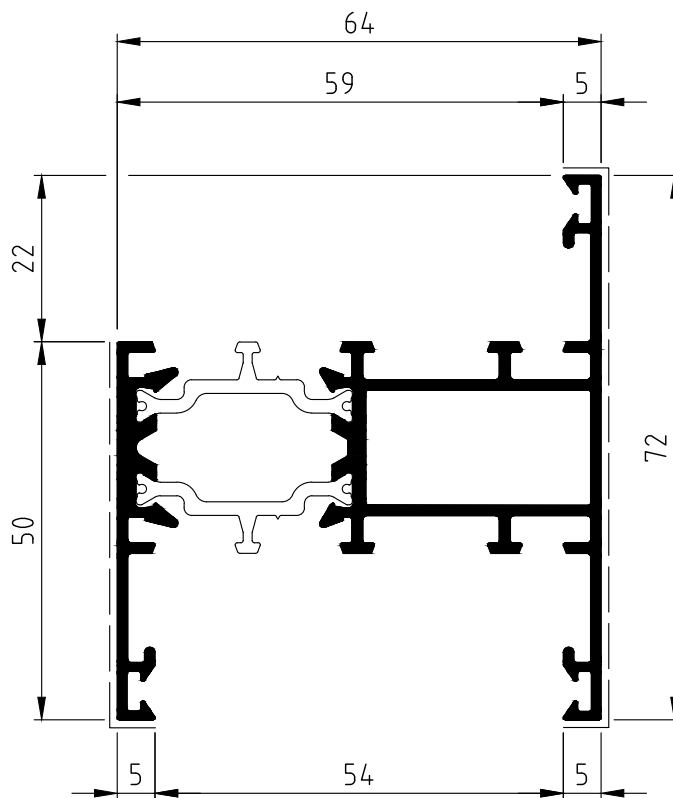

TELAI - APERTURA ESTERNA
FRAMES - OUTWARD OPENING

R2R72C89

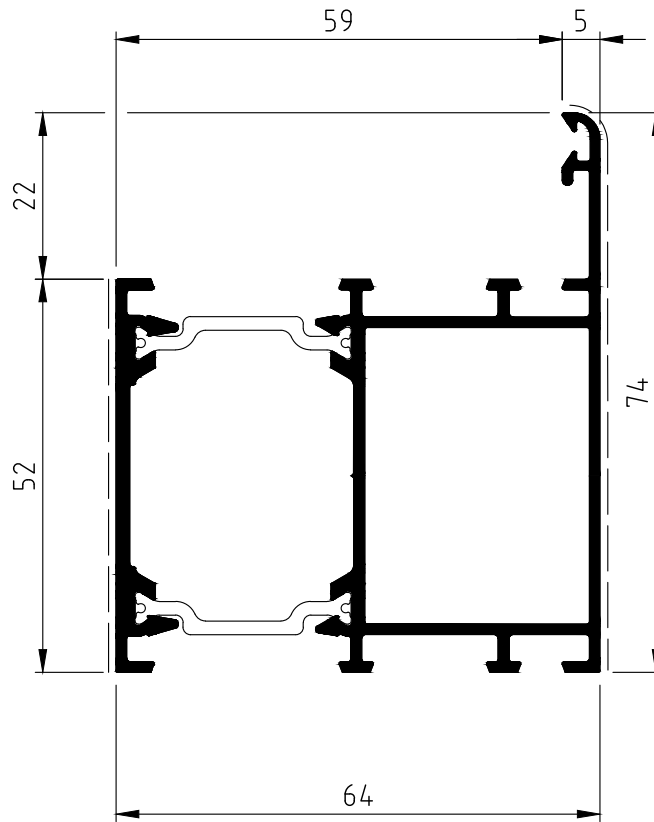

RR72C689

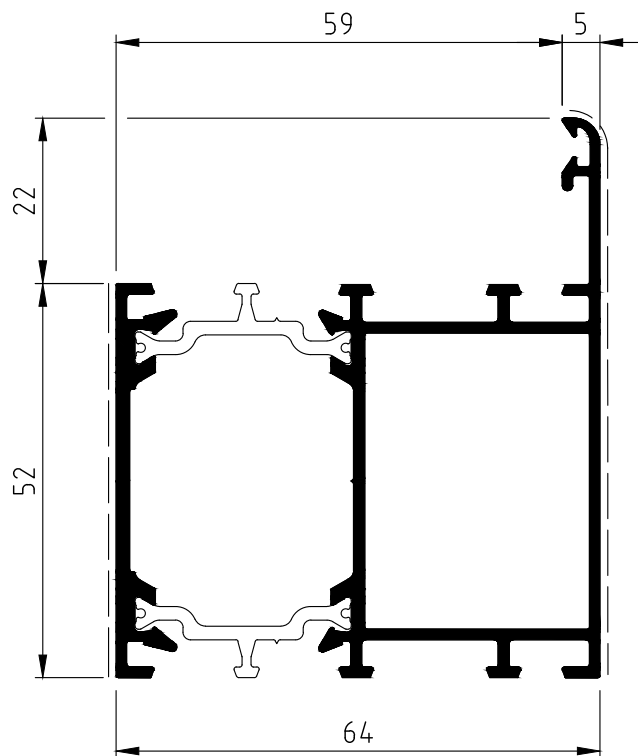

TELAJ - APERTURA ESTERNA
FRAMES - OUTWARD OPENING

R2R72C62

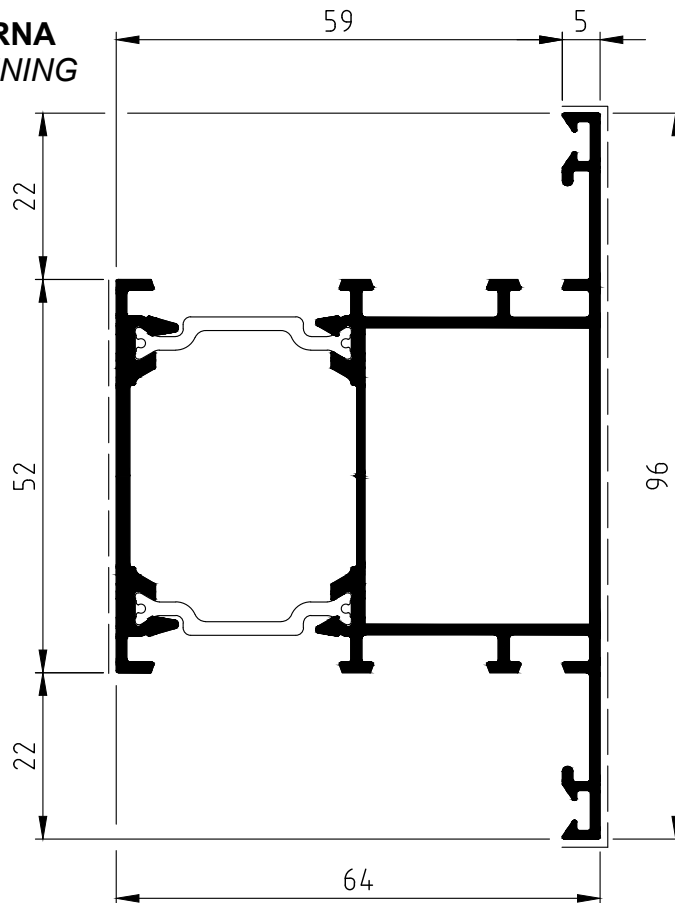

RR72C662

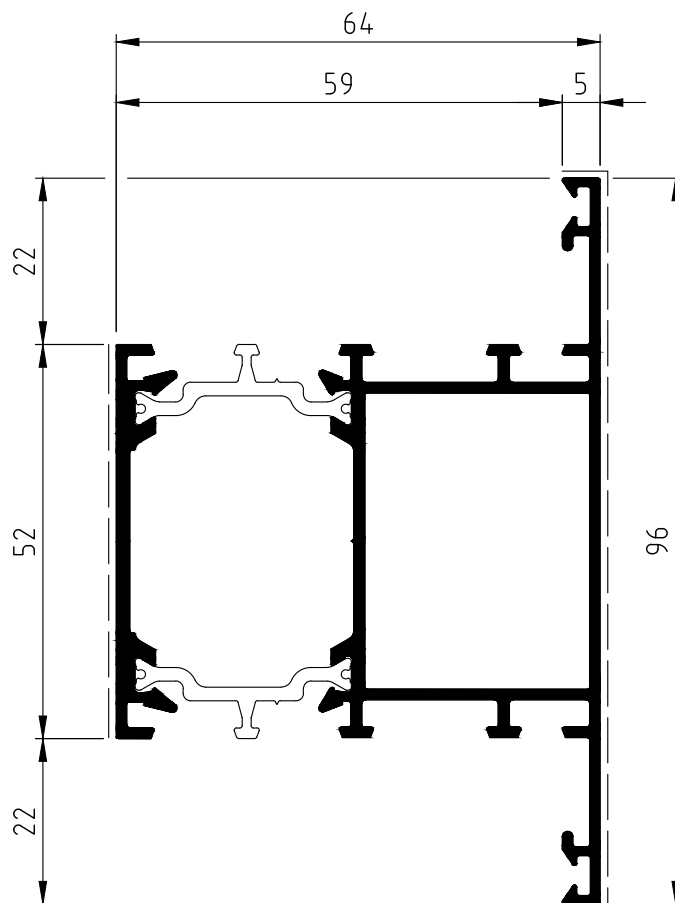

PROFILATI SPECIALI APERTURA ESTERNA
SPECIAL SECTIONS FOR OUTWARD OPENING

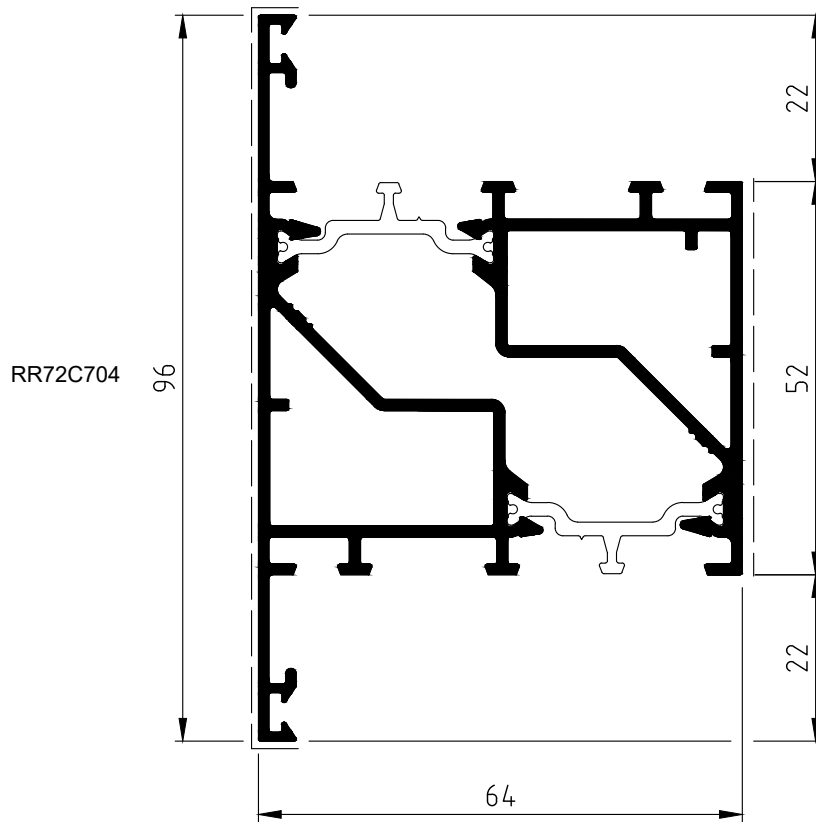

INVERSIONE DI BATTUTA
RABBET INVERSION

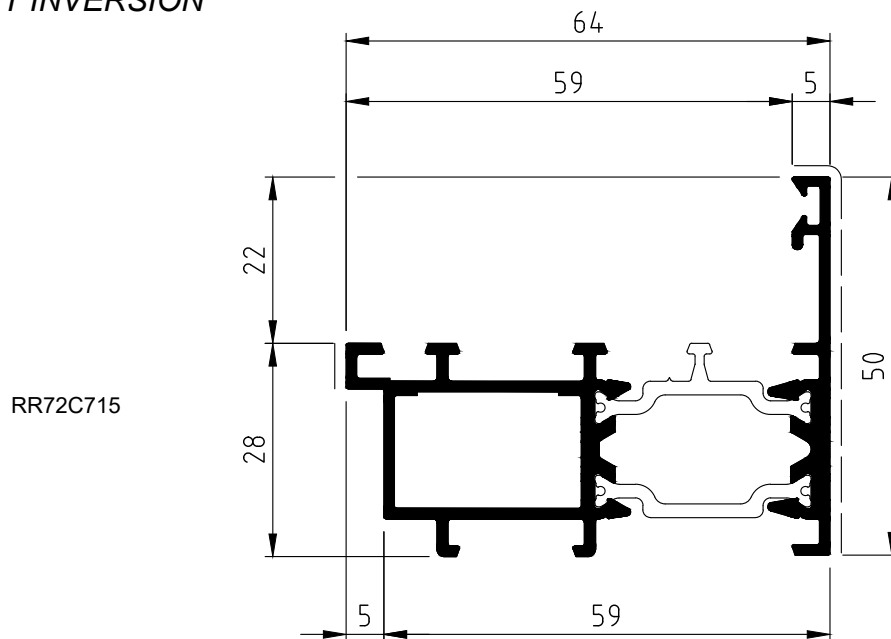

RIPORTO CENTRALE "APERTURA ESTERNA"
CENTRAL FILLING "OUTWARD OPENING"

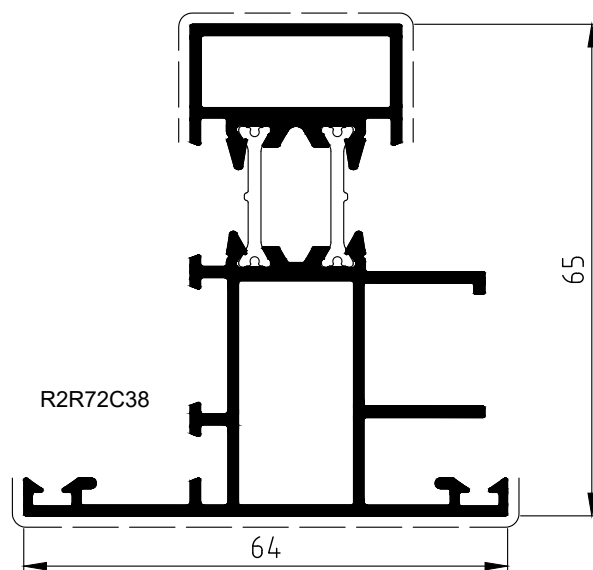

INVERSIONE PER BILICO
INVERSION FOR PIVOT WINDOW

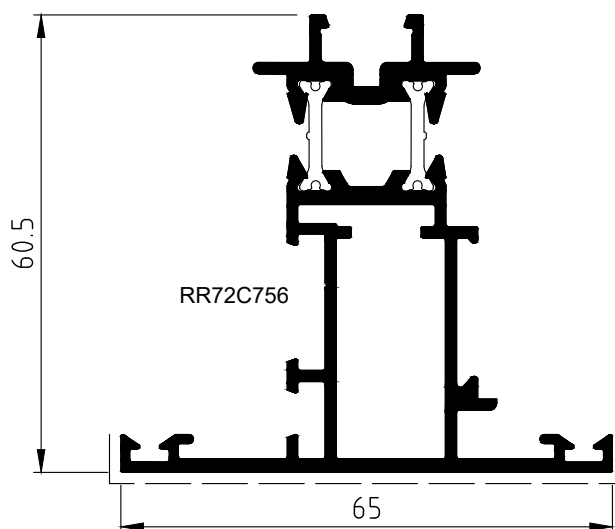

ANGOLI
CORNERS

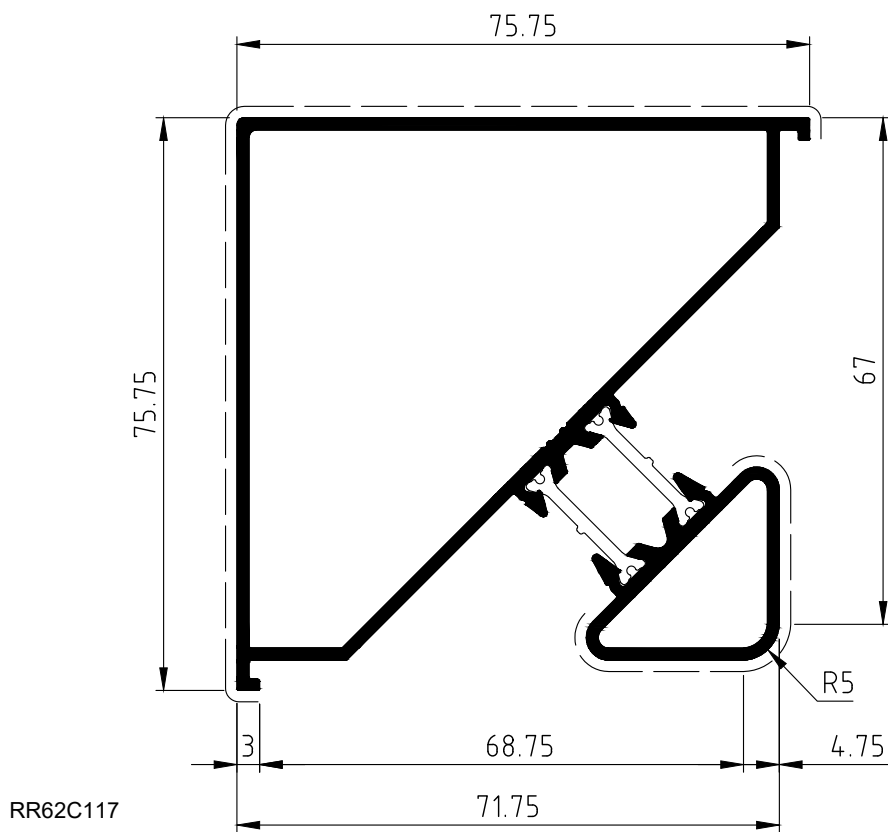
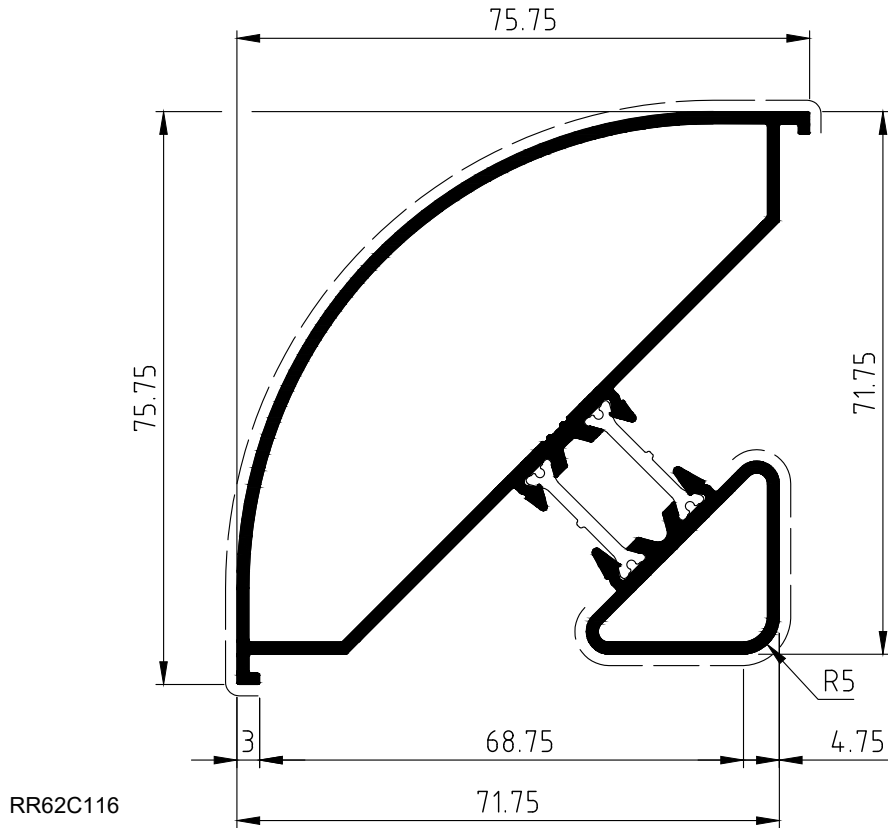

TELAI
FRAMES

TUBOLARI ESTERNI

RR72C731

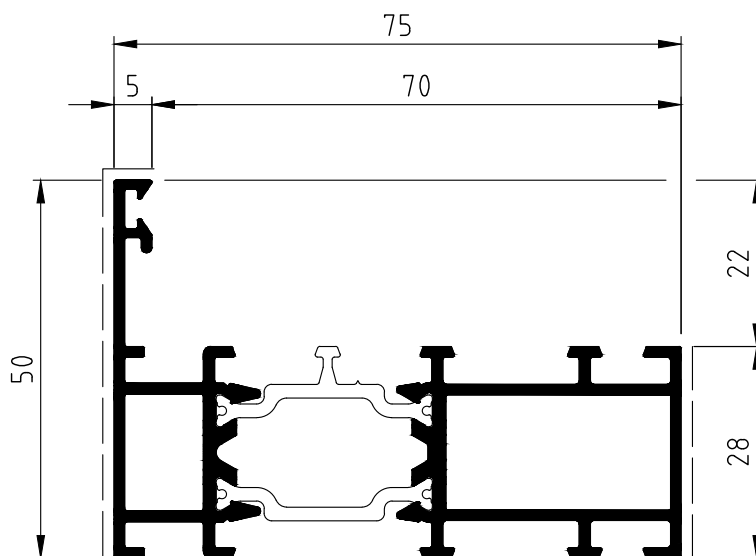

RR72C730

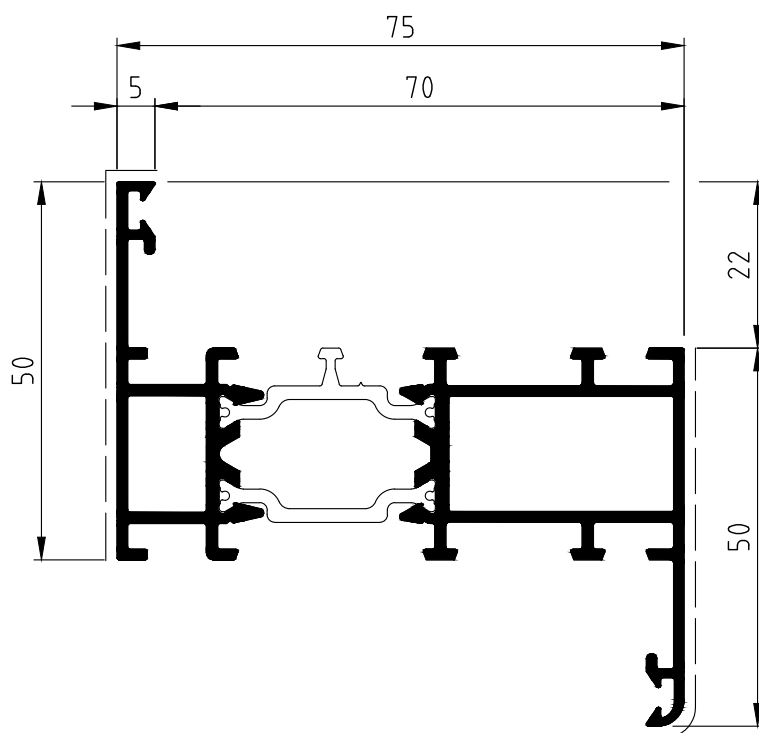

TELAI
FRAMES

TUBOLARI ESTERNI

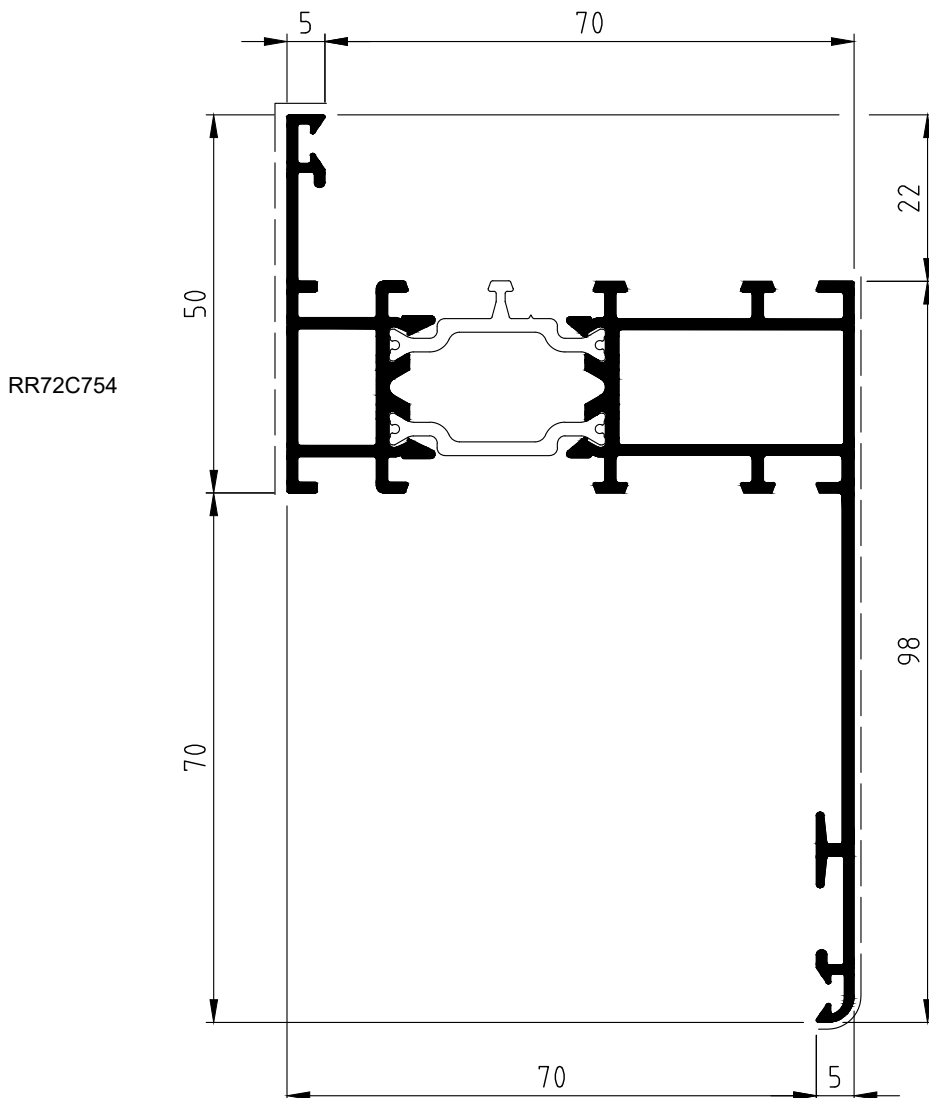

TELAI
FRAMES

TUBOLARI ESTERNI

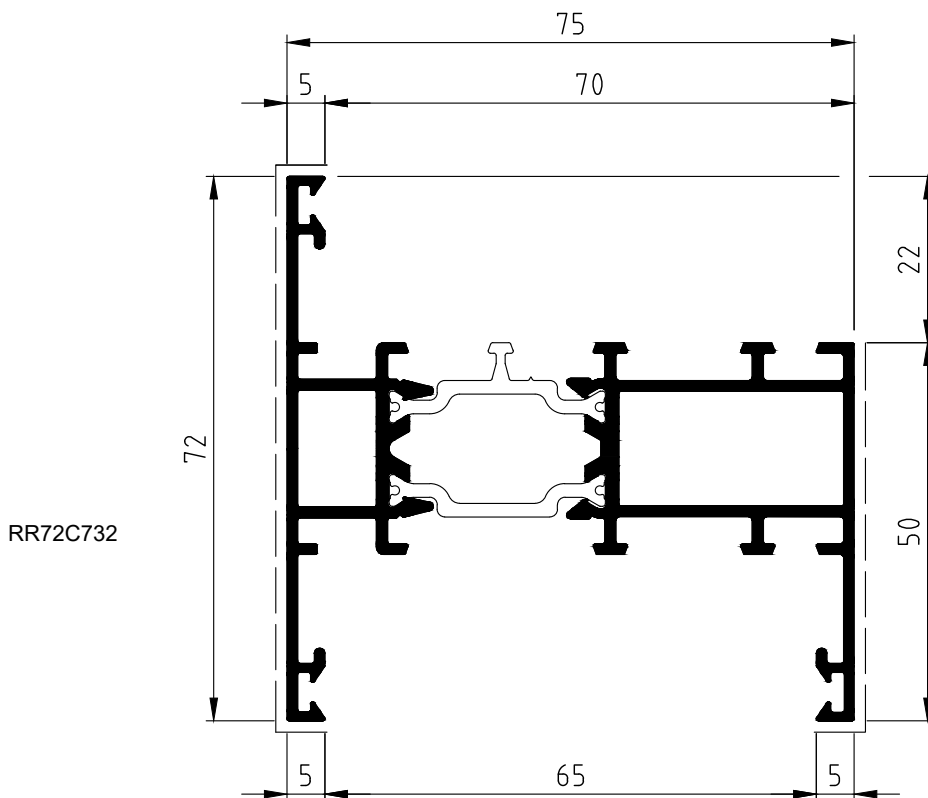
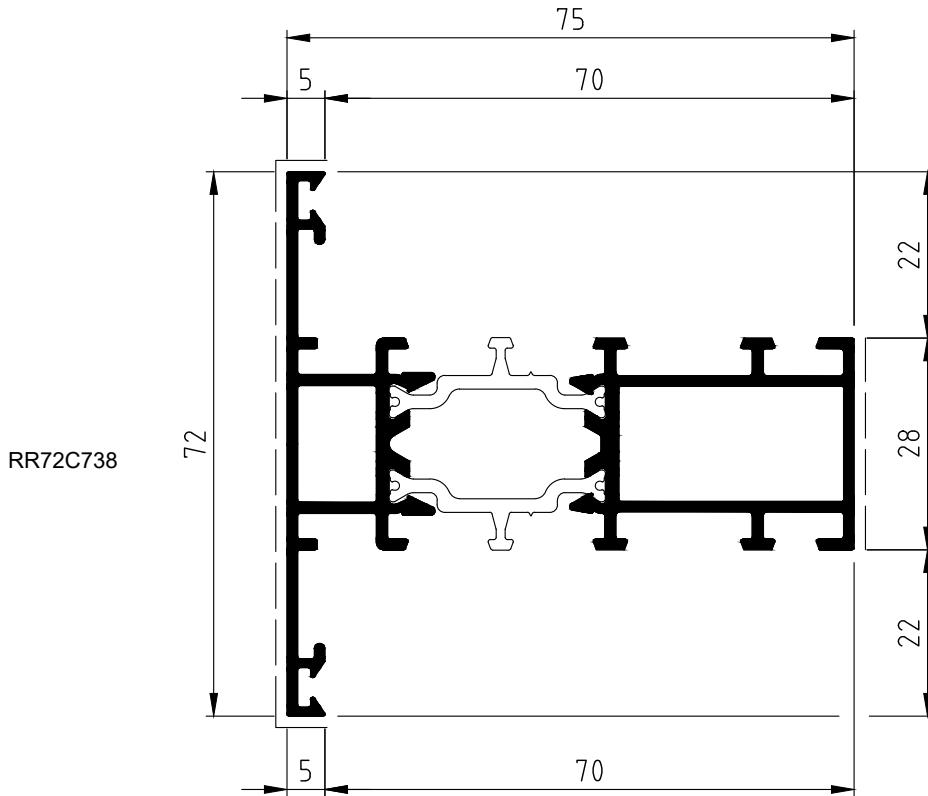

**TELAI
FRAMES**

TUBOLARI ESTERNI

RR72C750

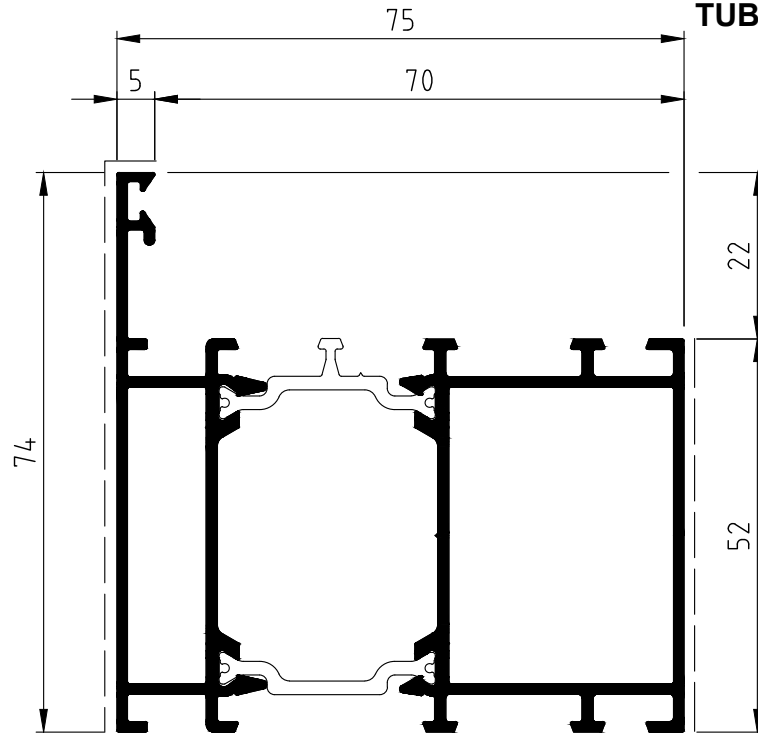

RR72C751

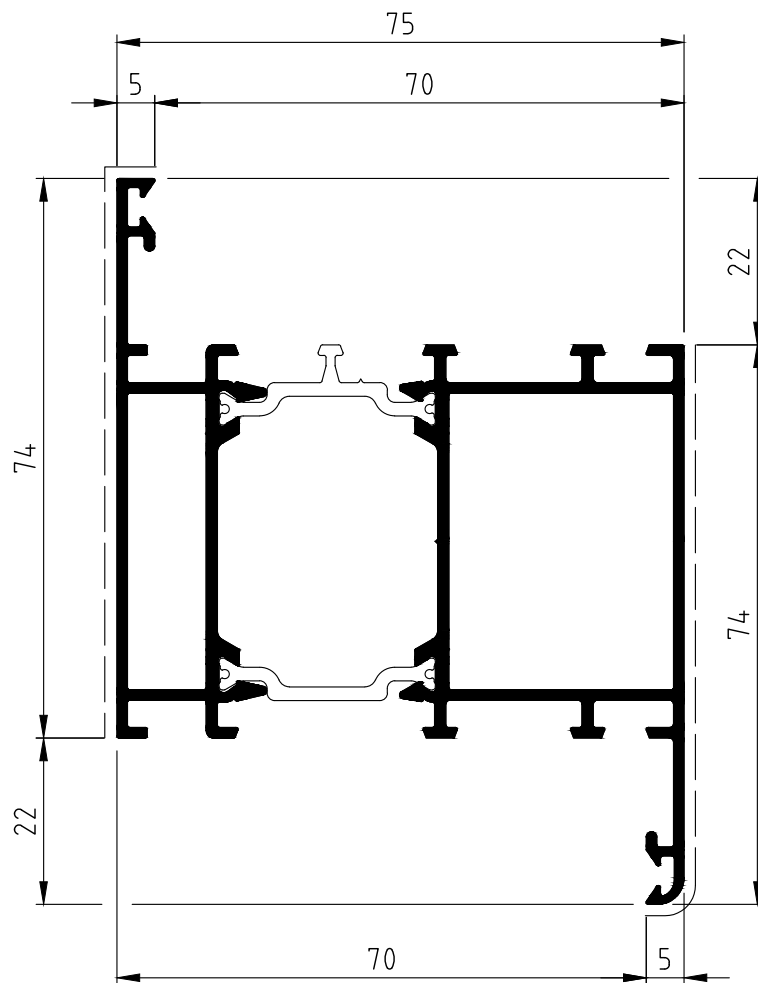

TELAI
FRAMES

TUBOLARI ESTERNI

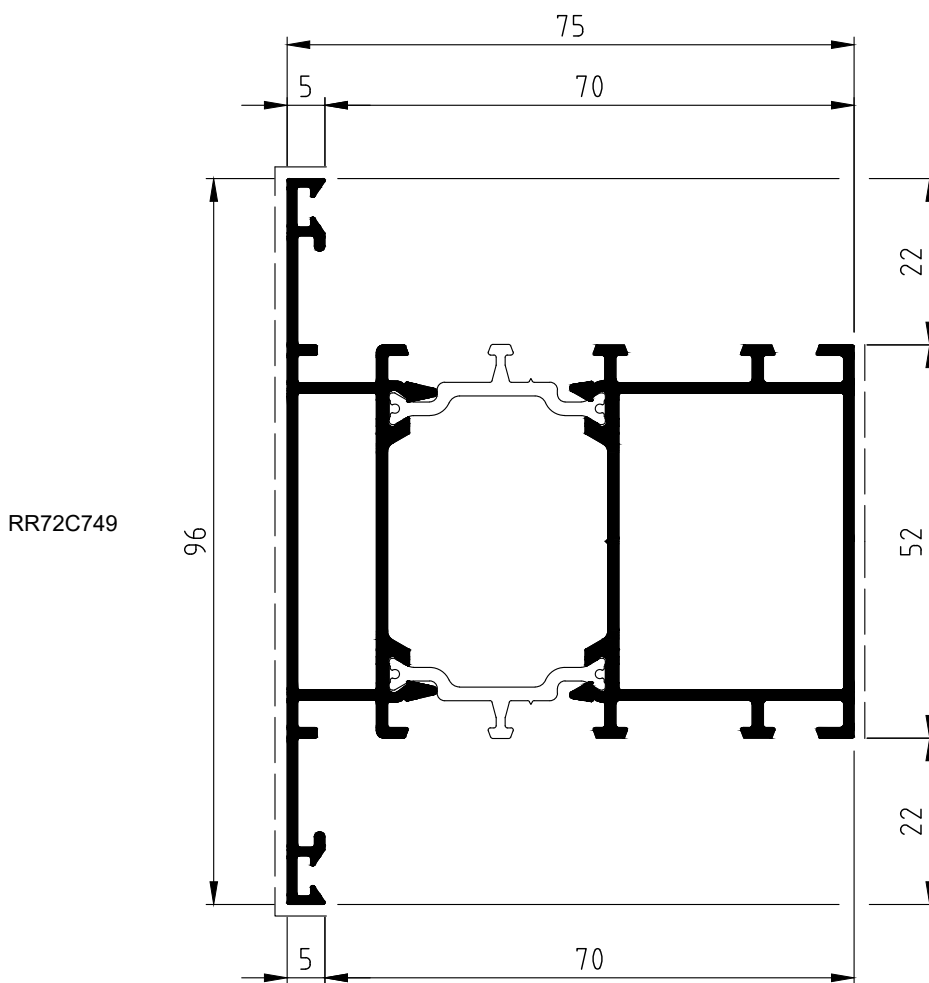

ANTE
WINGS

TUBOLARI ESTERNI

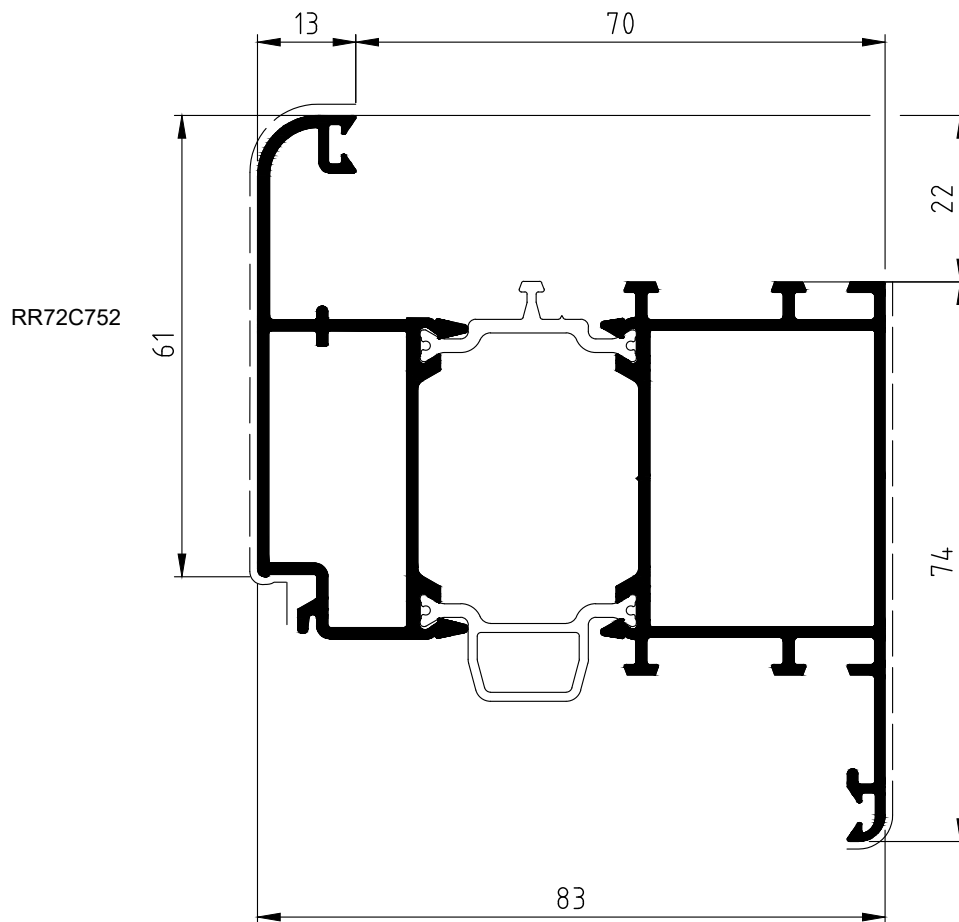
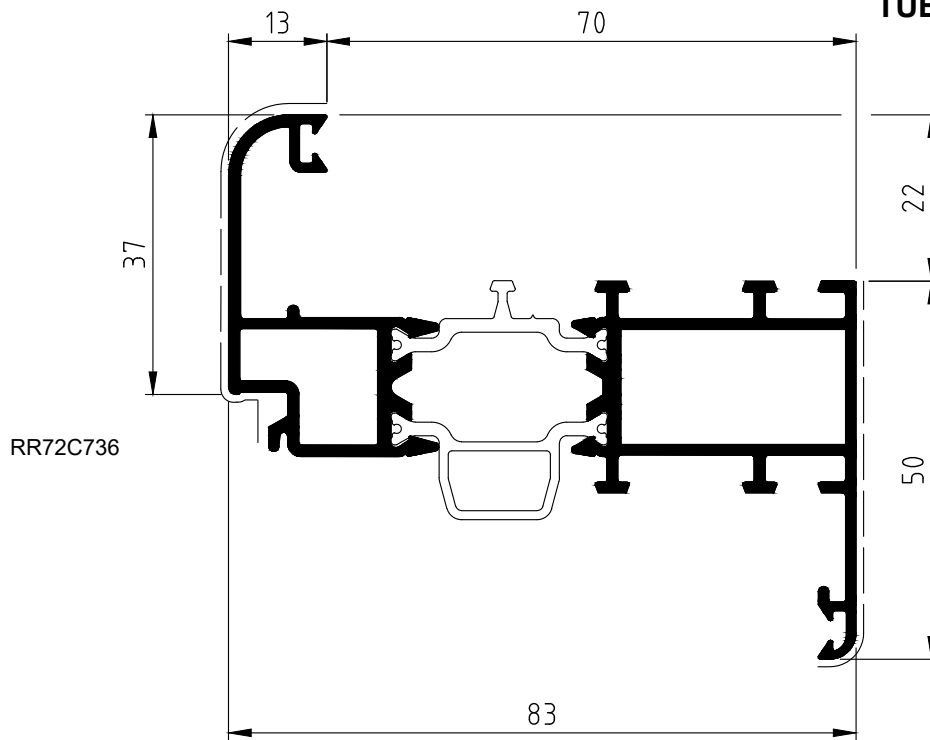

RIPORTO CENTRALE
CENTRAL FILLING

TUBOLARI ESTERNI

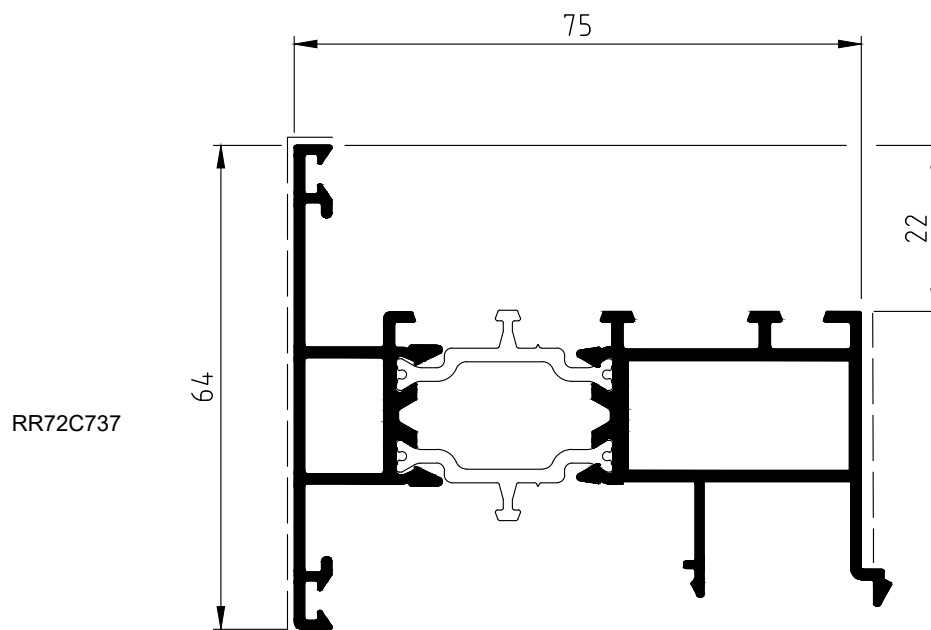

FASCE - ZOCCOLI
BANDS - SKIRTING BOARDS

TUBOLARI ESTERNI

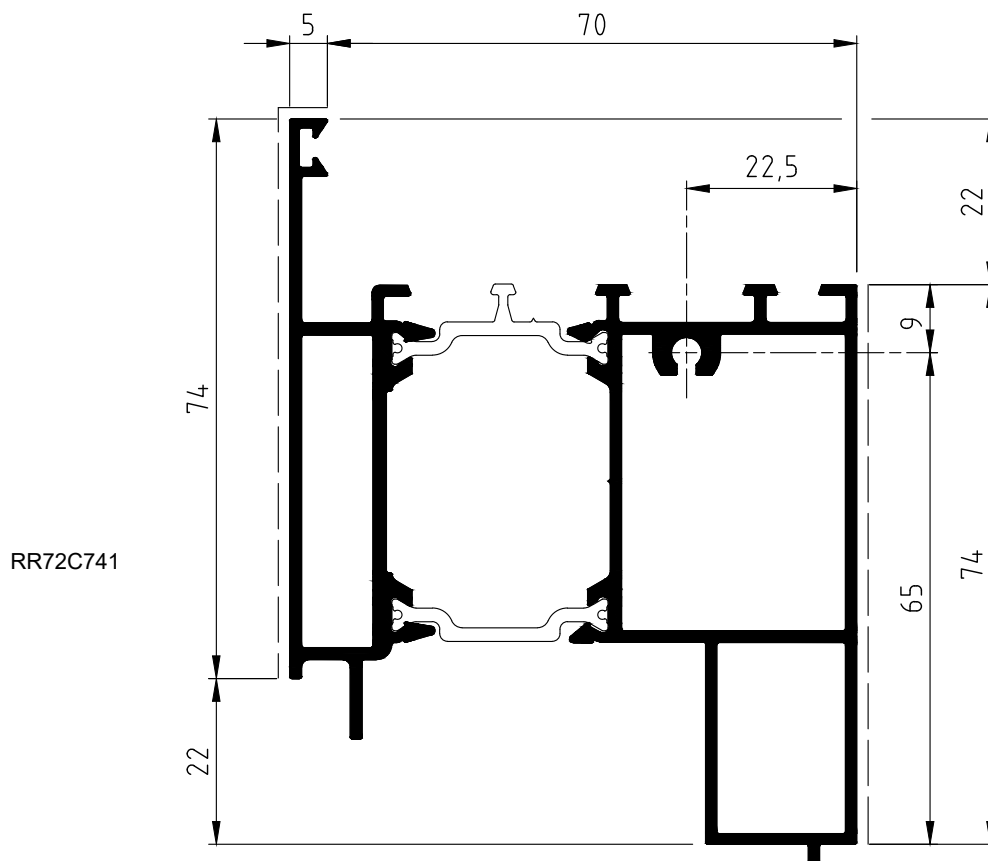
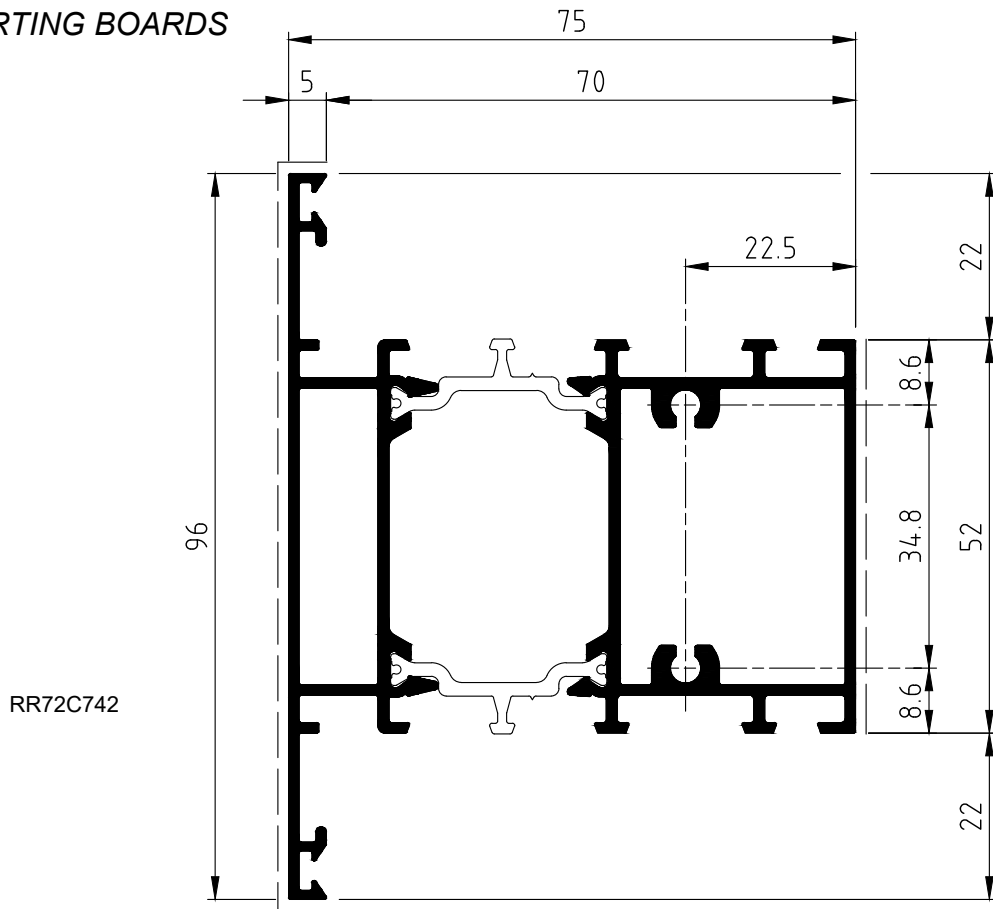

FASCE - ZOCCOLI
BANDS - SKIRTING BOARDS

TUBOLARI ESTERNI

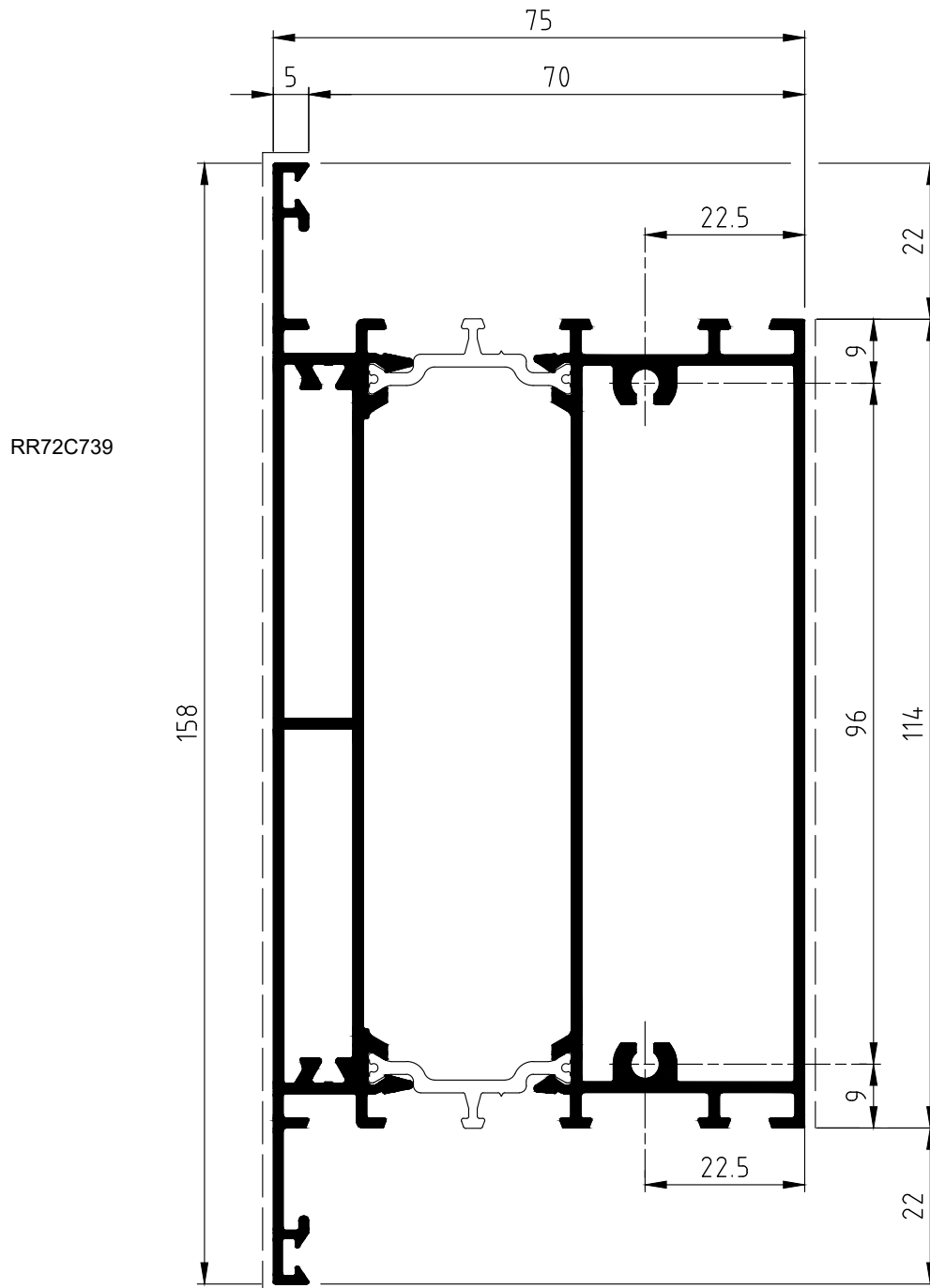

FASCE - ZOCCOLI
BANDS - SKIRTING BOARDS

TUBOLARI ESTERNI

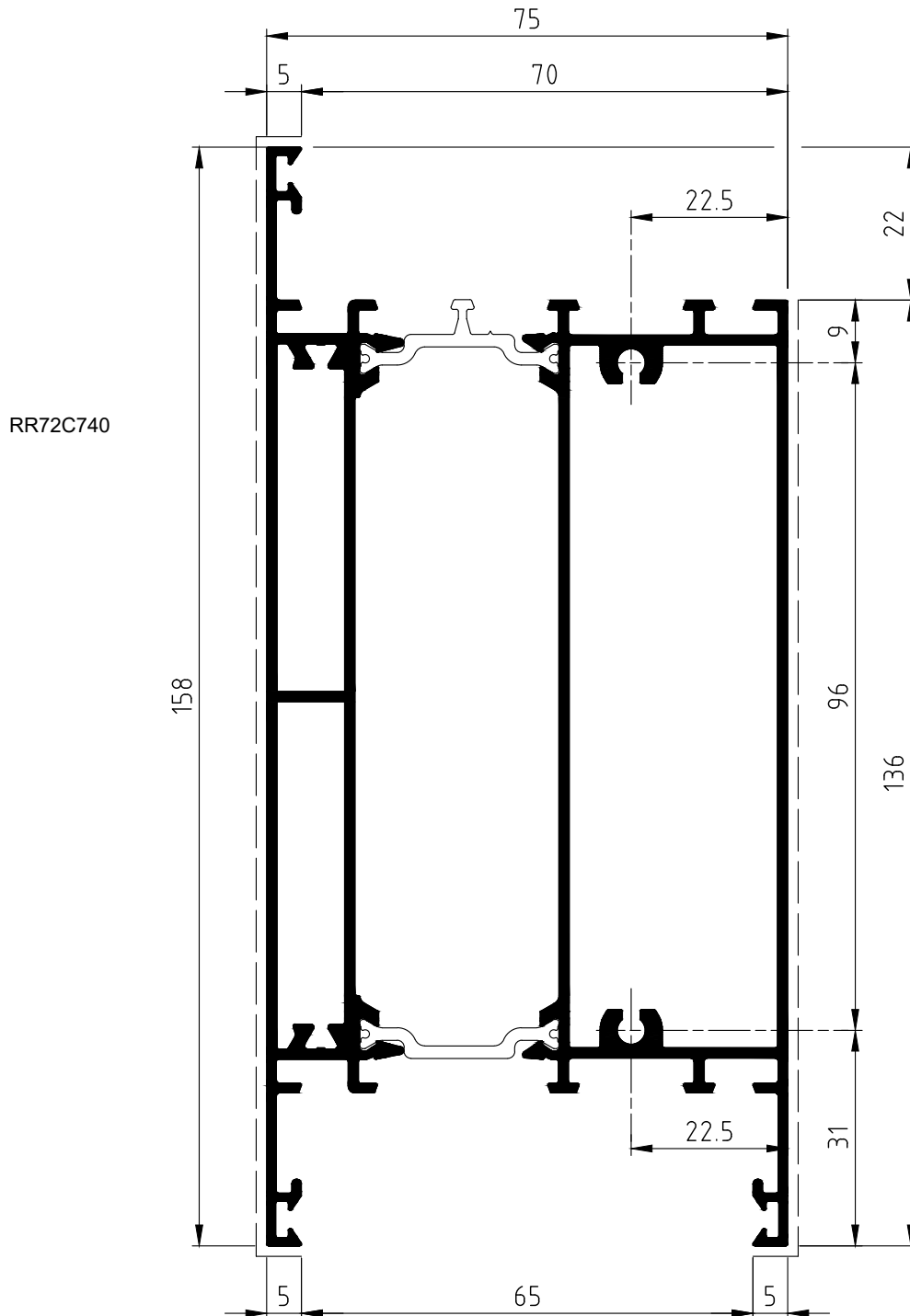

TELAI - APERTURA ESTERNA
FRAMES - OUTWARD OPENING

TUBOLARI ESTERNI

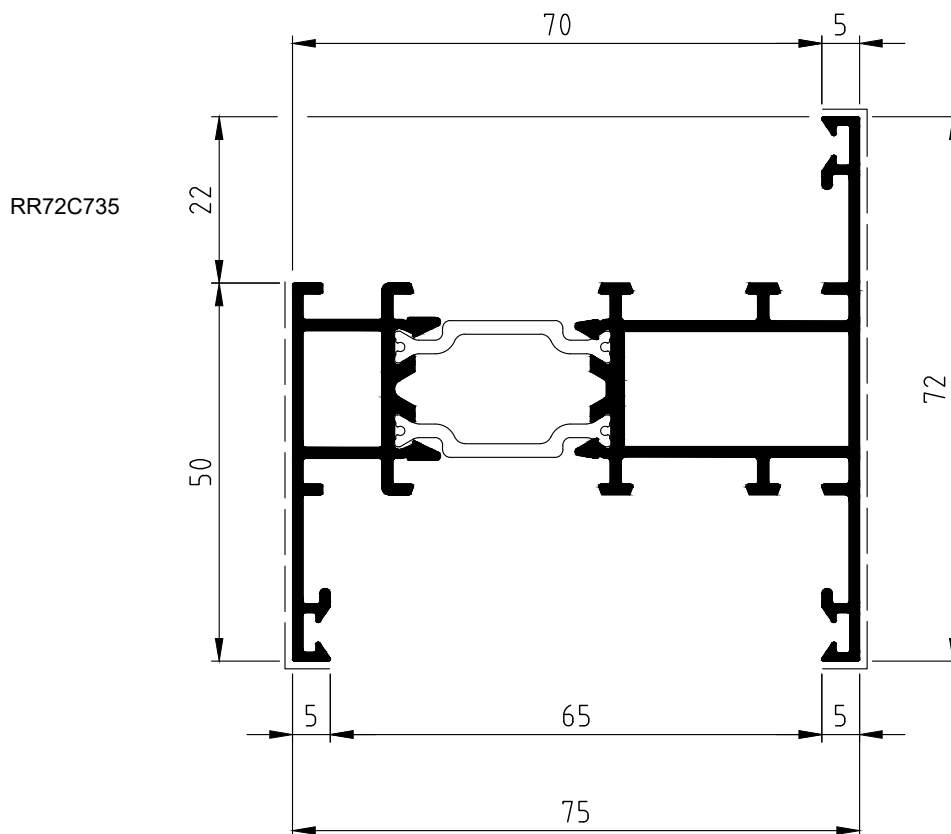

TELAI
FRAMES

TUBOLARI ESTERNI RIDOTTI

RR72C775

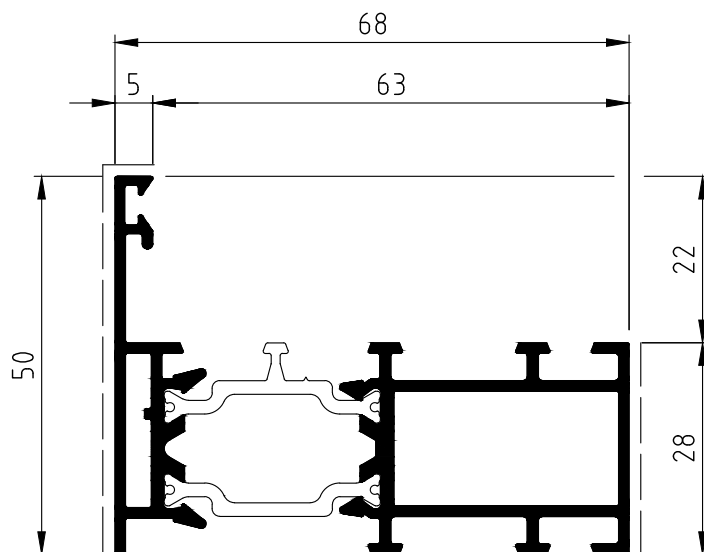

RR72C793

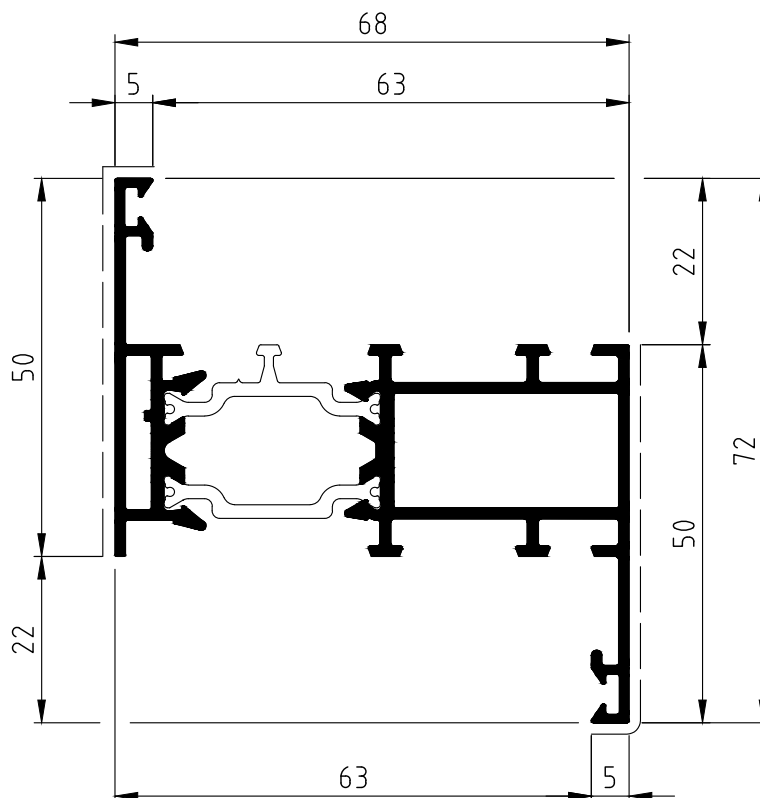

**TELAJ
FRAMES**

TUBOLARI ESTERNI RIDOTTI

RR72C776

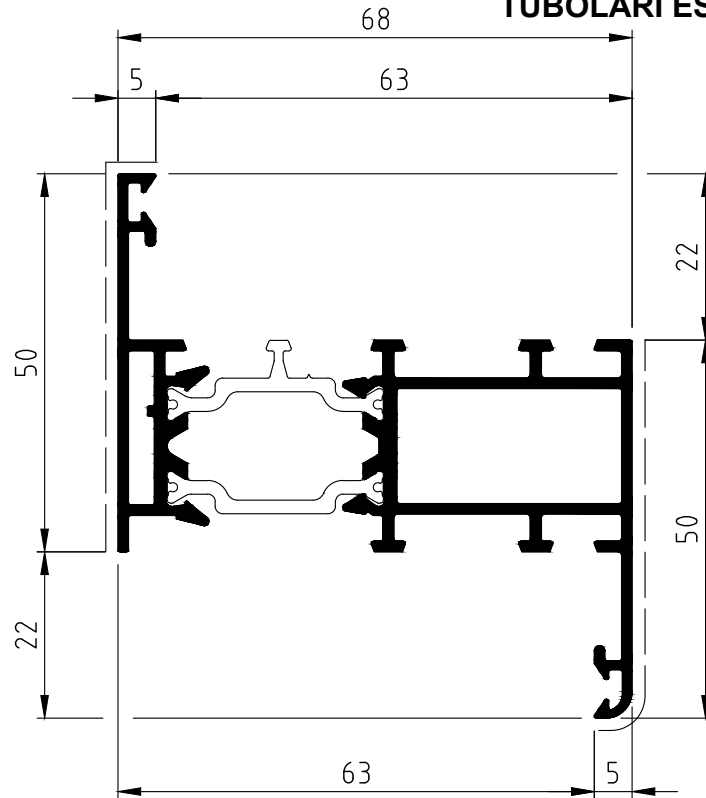

RR72C787

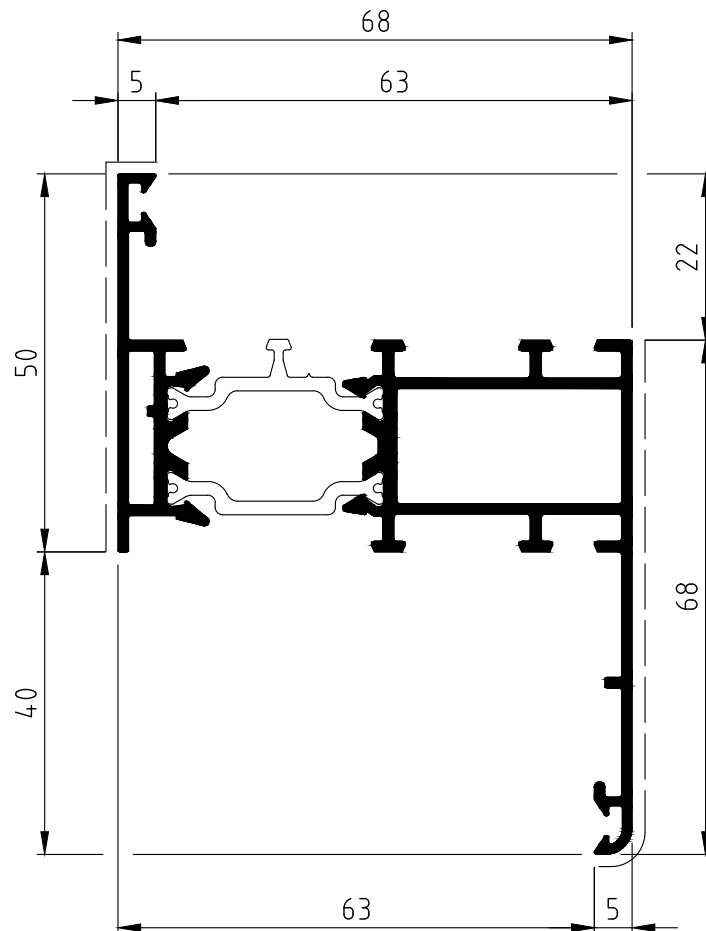

TELAI
FRAMES

TUBOLARI ESTERNI RIDOTTI

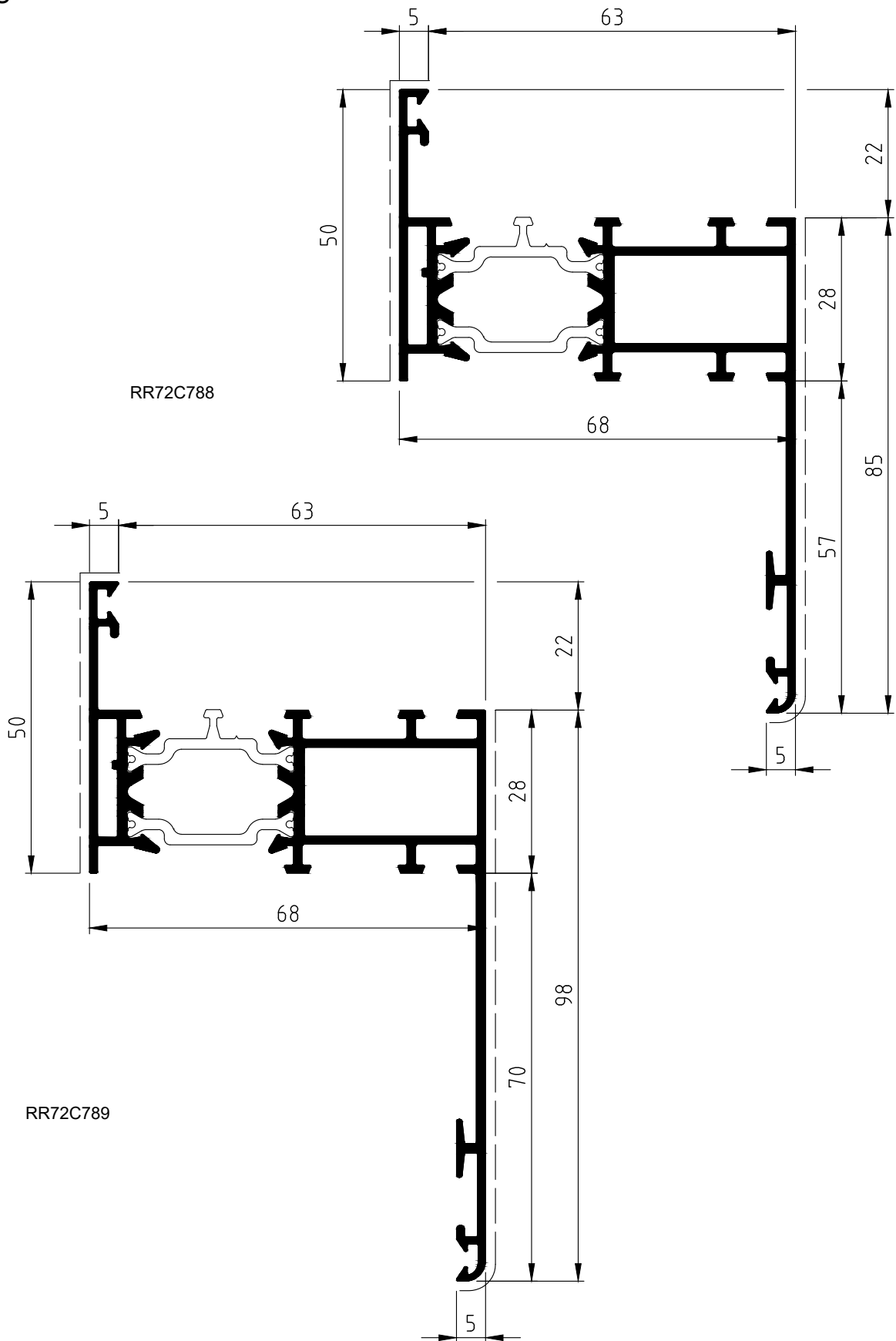

TELAJ
FRAMES

TUBOLARI ESTERNI RIDOTTI

RR72C796

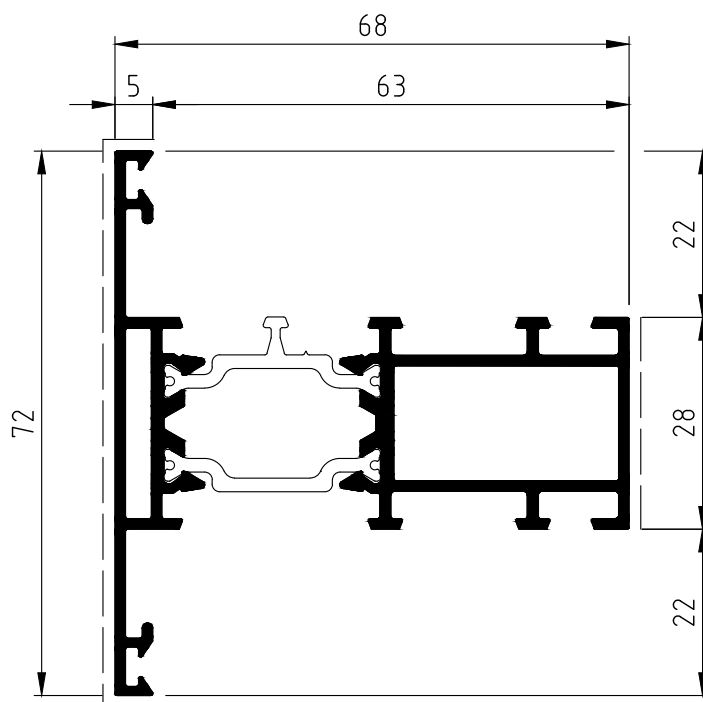

RR72C792

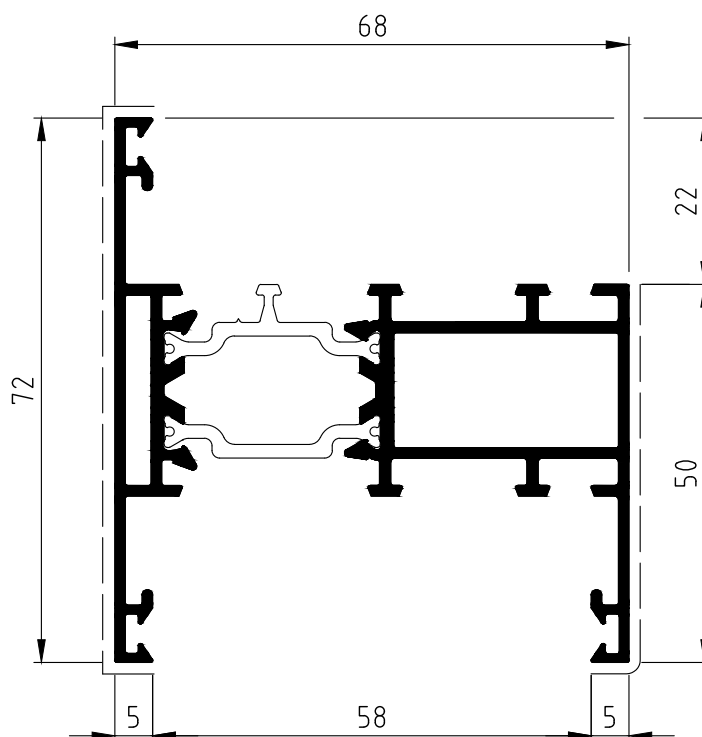

TELAI
FRAMES

TUBOLARI ESTERNI RIDOTTI

RR72C791

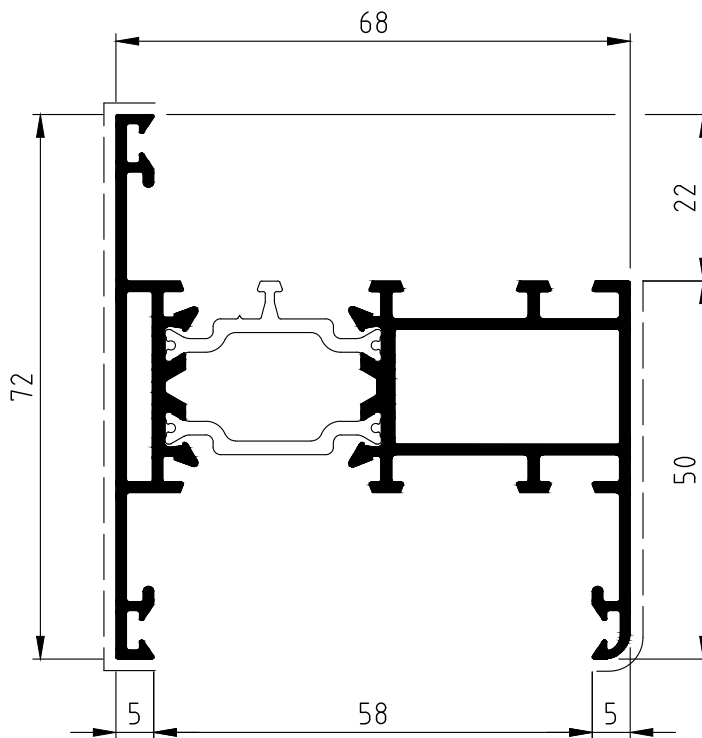

TELAJ
FRAMES

TUBOLARI ESTERNI RIDOTTI

RR72C784

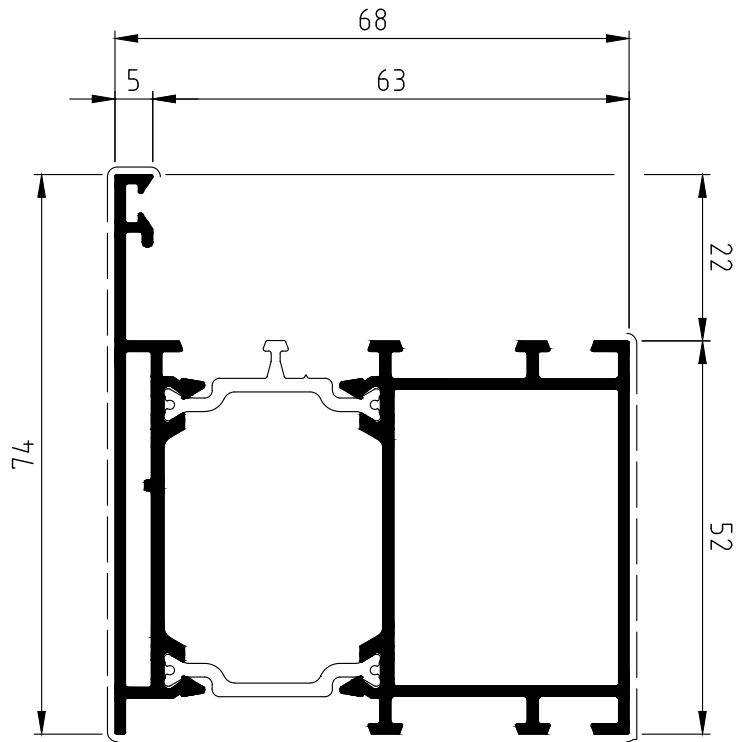

RR72C782

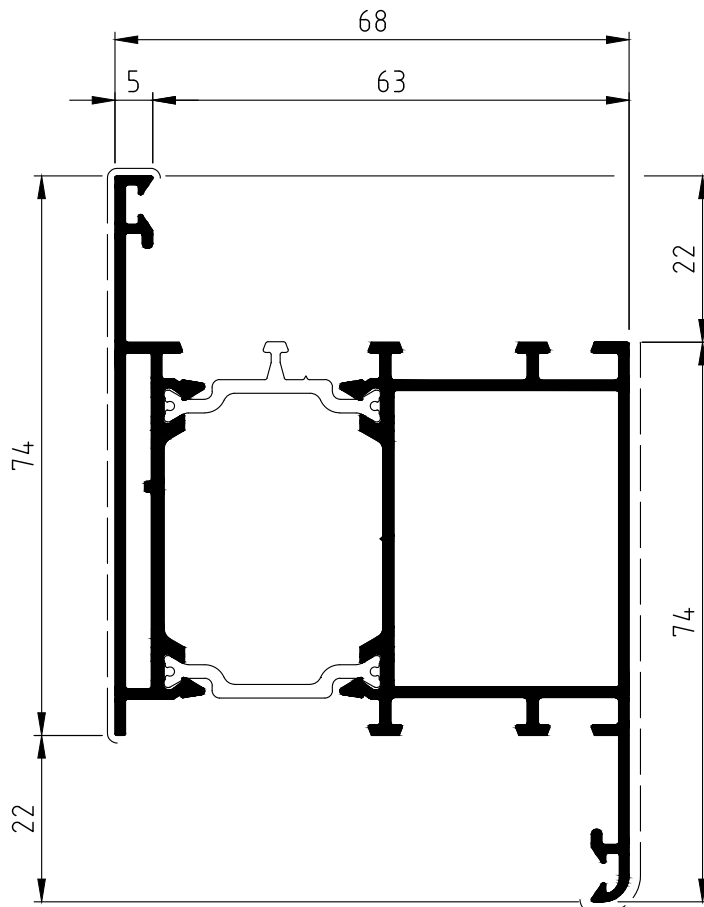

TELAI
FRAMES

TUBOLARI ESTERNI RIDOTTI

RR72C797

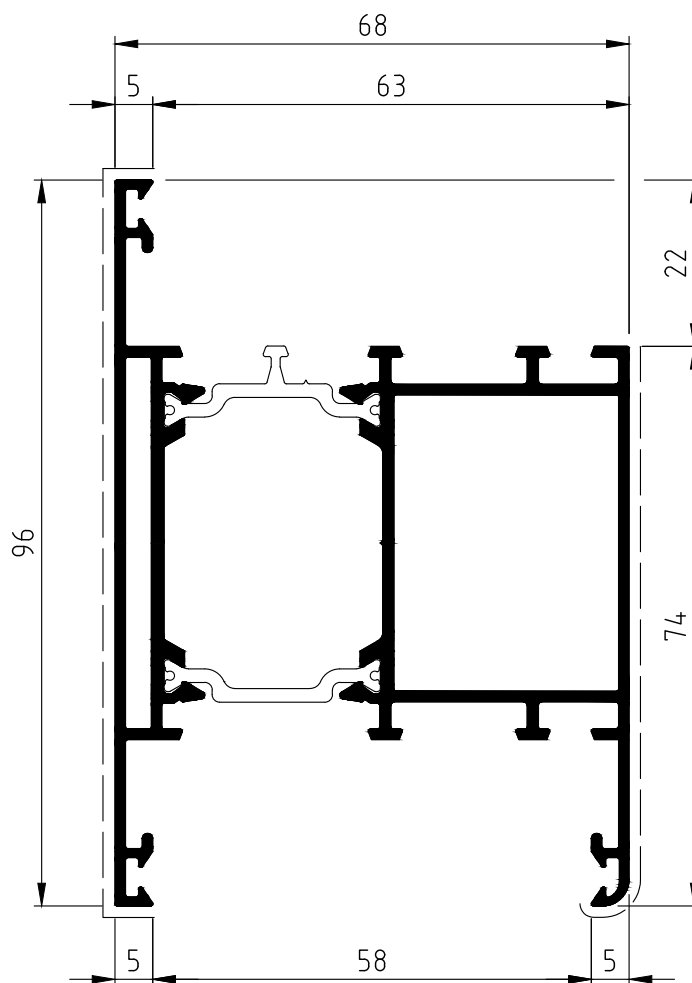

ANTE
WINGS

TUBOLARI ESTERNI RIDOTTI

RR72C798
MATRICE DA COSTRUIRE

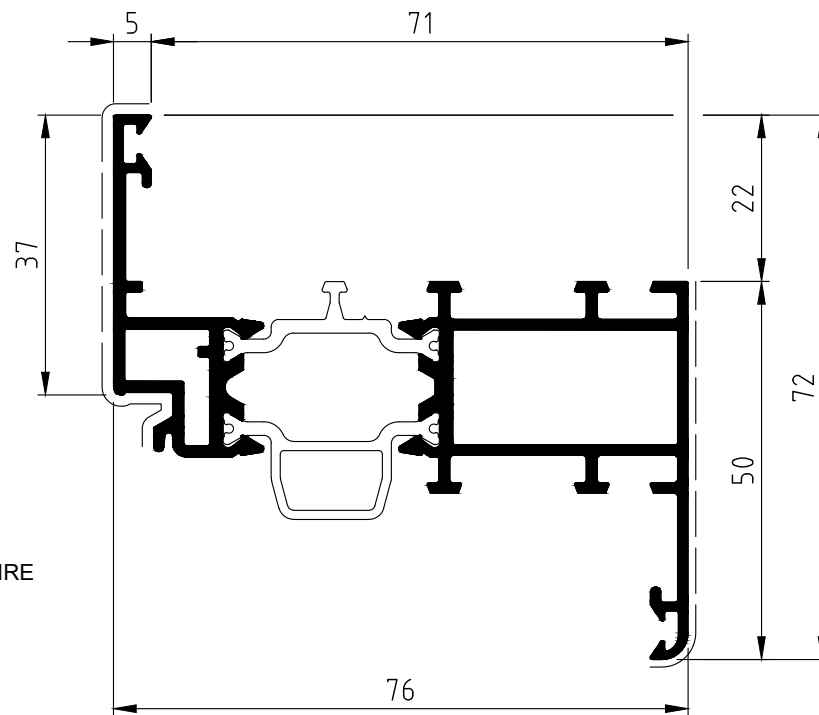

RR72C799
MATRICE DA COSTRUIRE

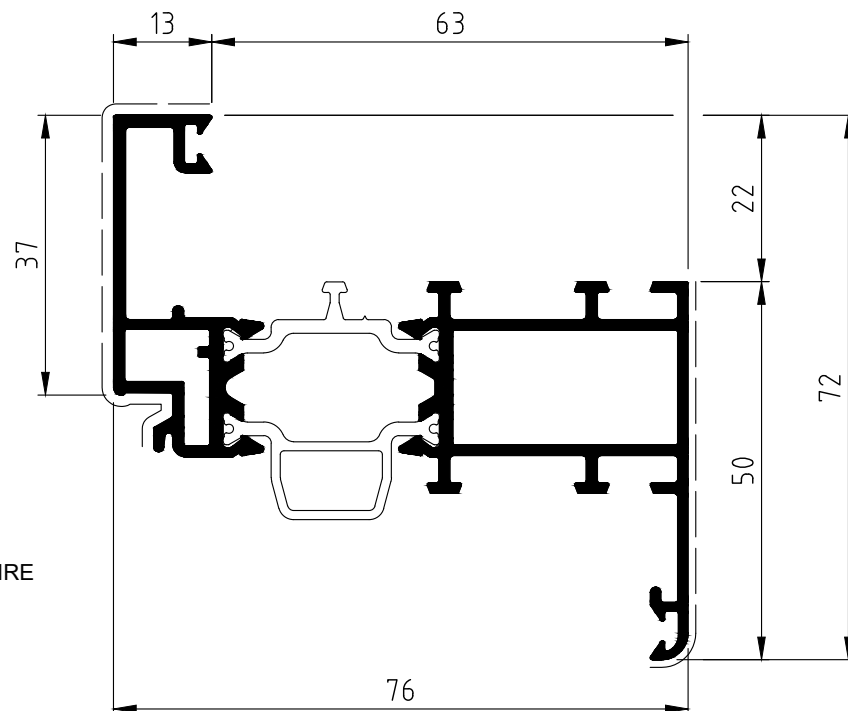

ANTE
WINGS

TUBOLARI ESTERNI RIDOTTI

RR72C777

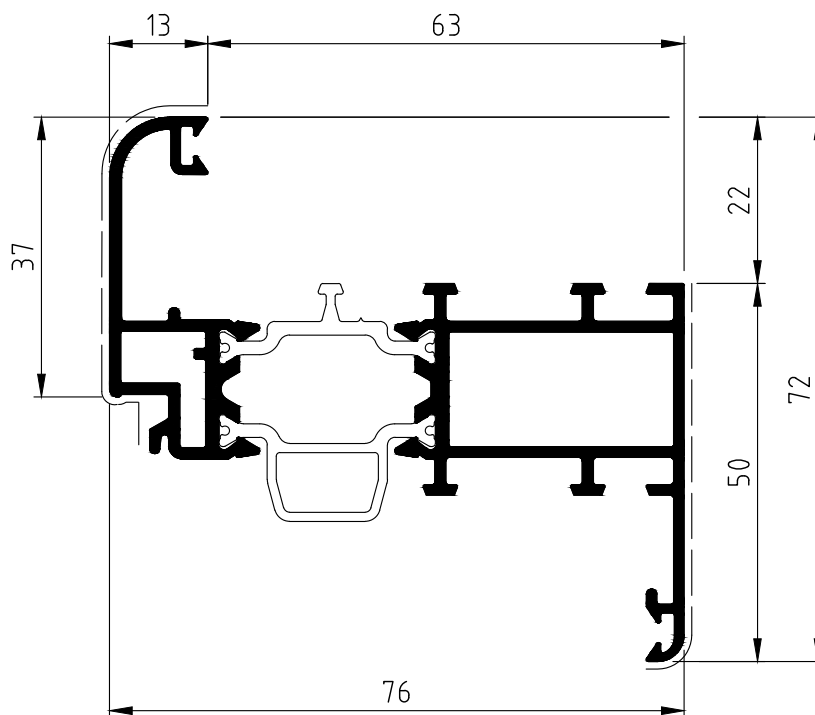

ANTE
WINGS

TUBOLARI ESTERNI RIDOTTI

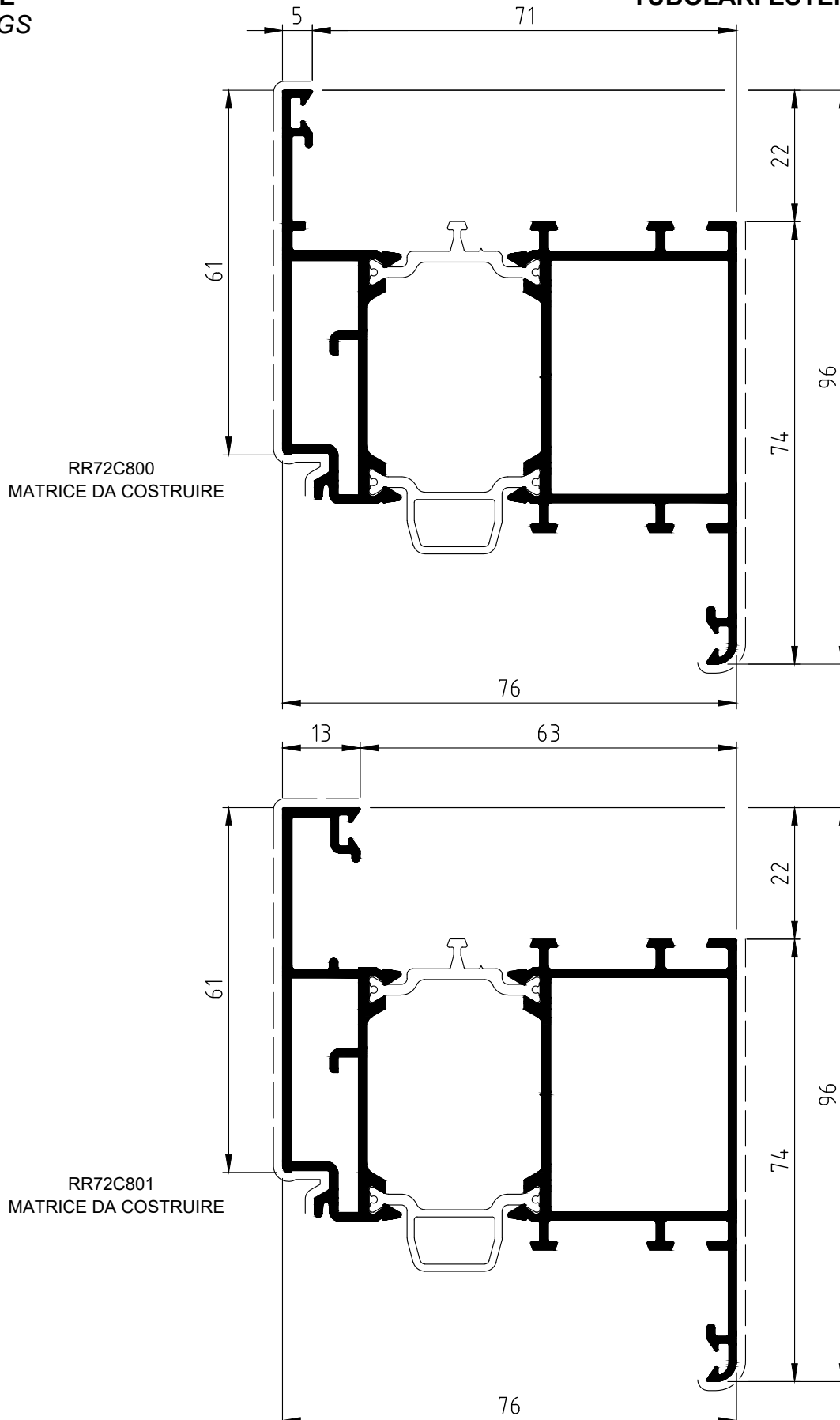

ANTE
WINGS

TUBOLARI ESTERNI RIDOTTI

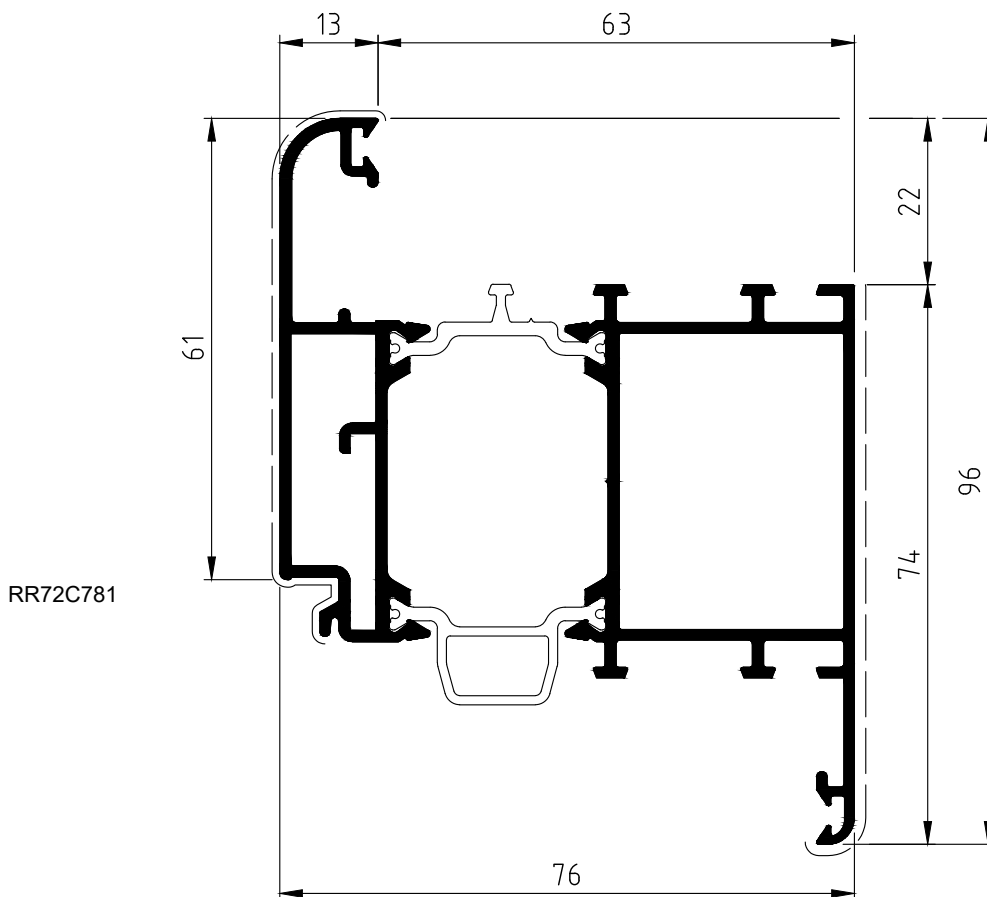

RIPORTO CENTRALE
CENTRAL FILLING

TUBOLARI ESTERNI RIDOTTI

RR72C778

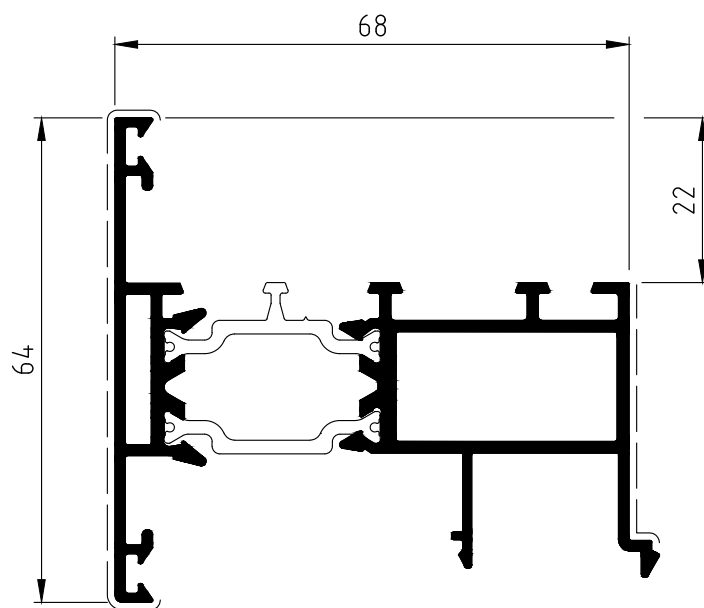

TRAVERSI
TRANSOM

TUBOLARI ESTERNI RIDOTTI

RR72C779

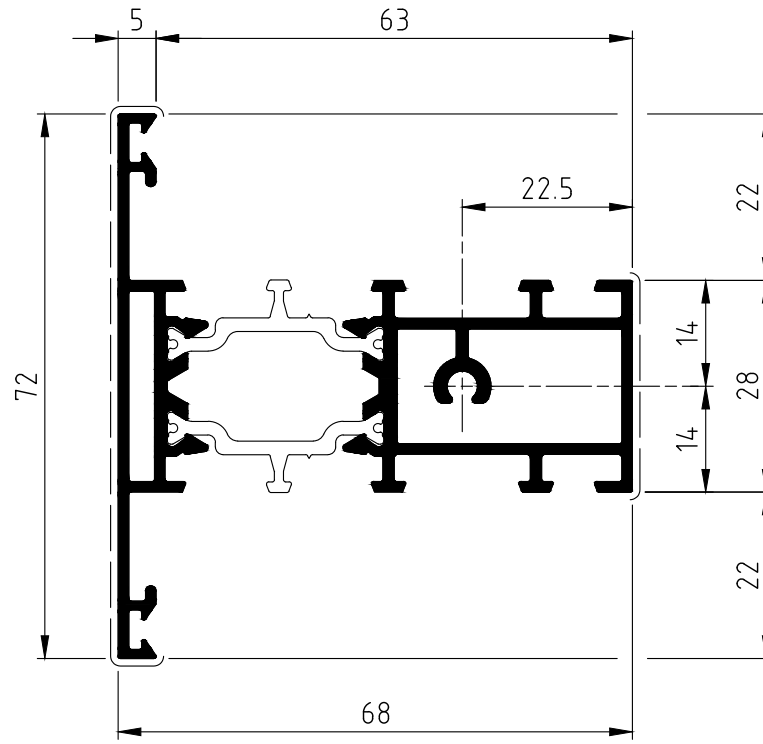

RR72C785

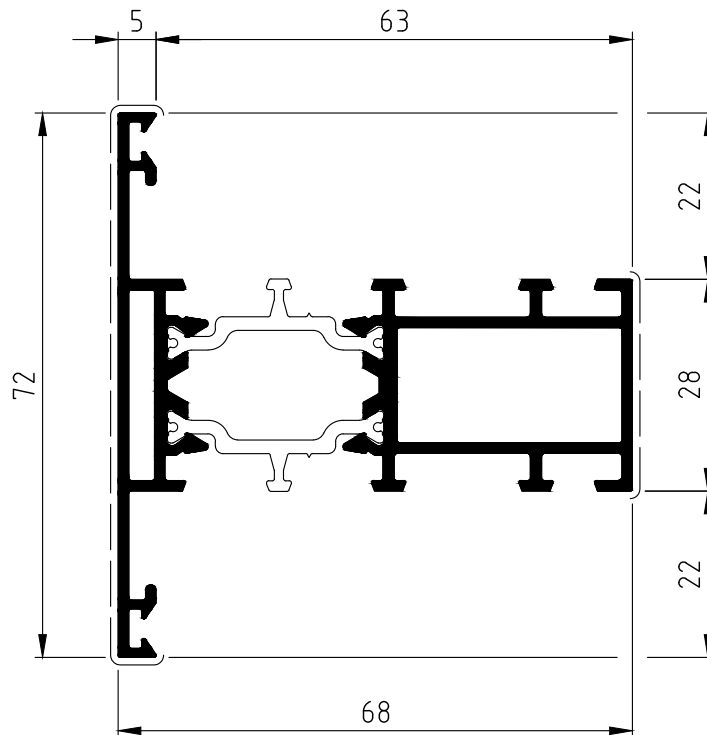

**TRAVERSI
TRANSOM**

TUBOLARI ESTERNI RIDOTTI

RR72C783

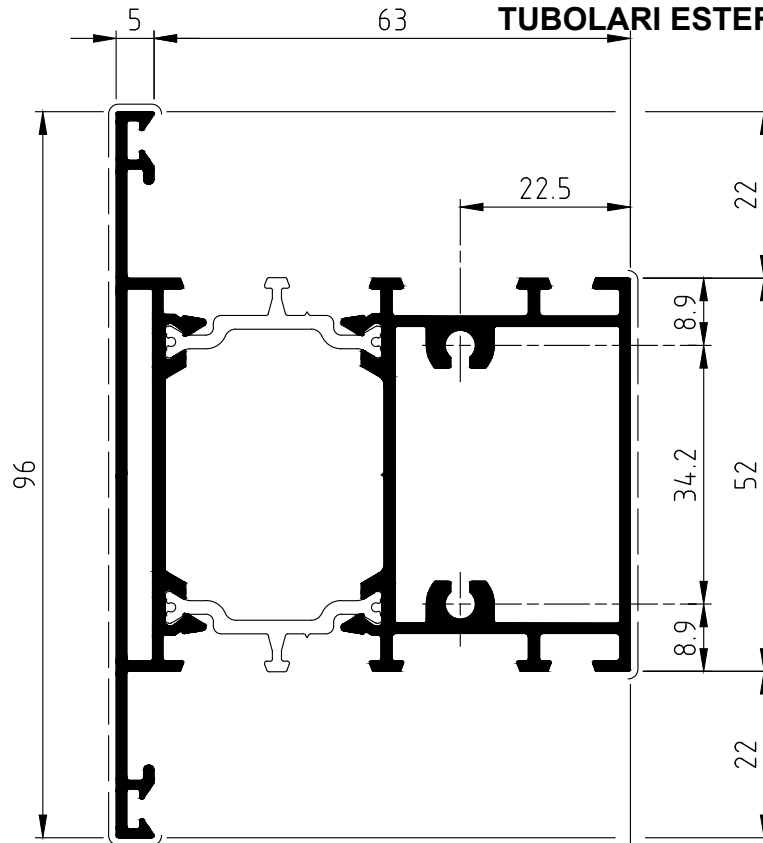

RR72C786

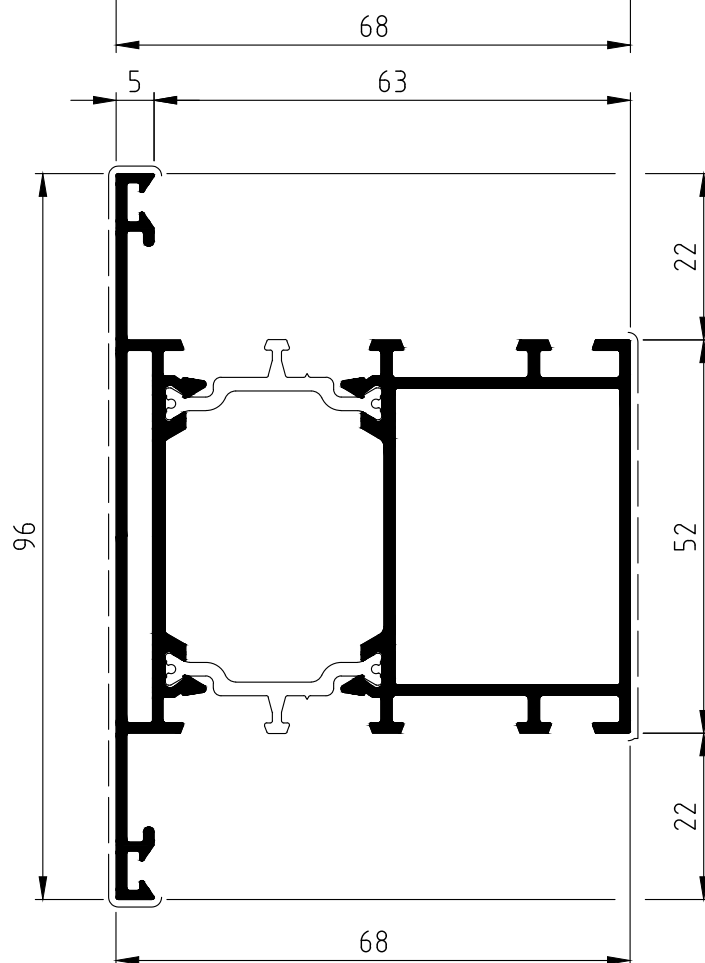

FASCE - ZOCCOLI
BANDS - SKIRTING BOARDS

TUBOLARI ESTERNI RIDOTTI

RR72C780

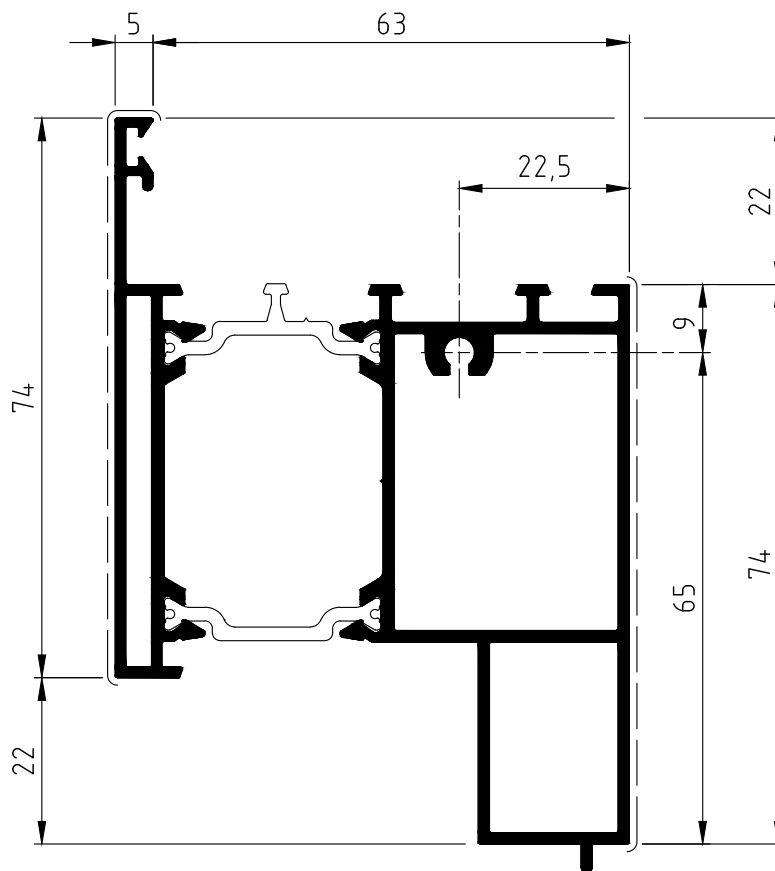

ANTE A SCOMPARSA
INVISIBLE WINGS

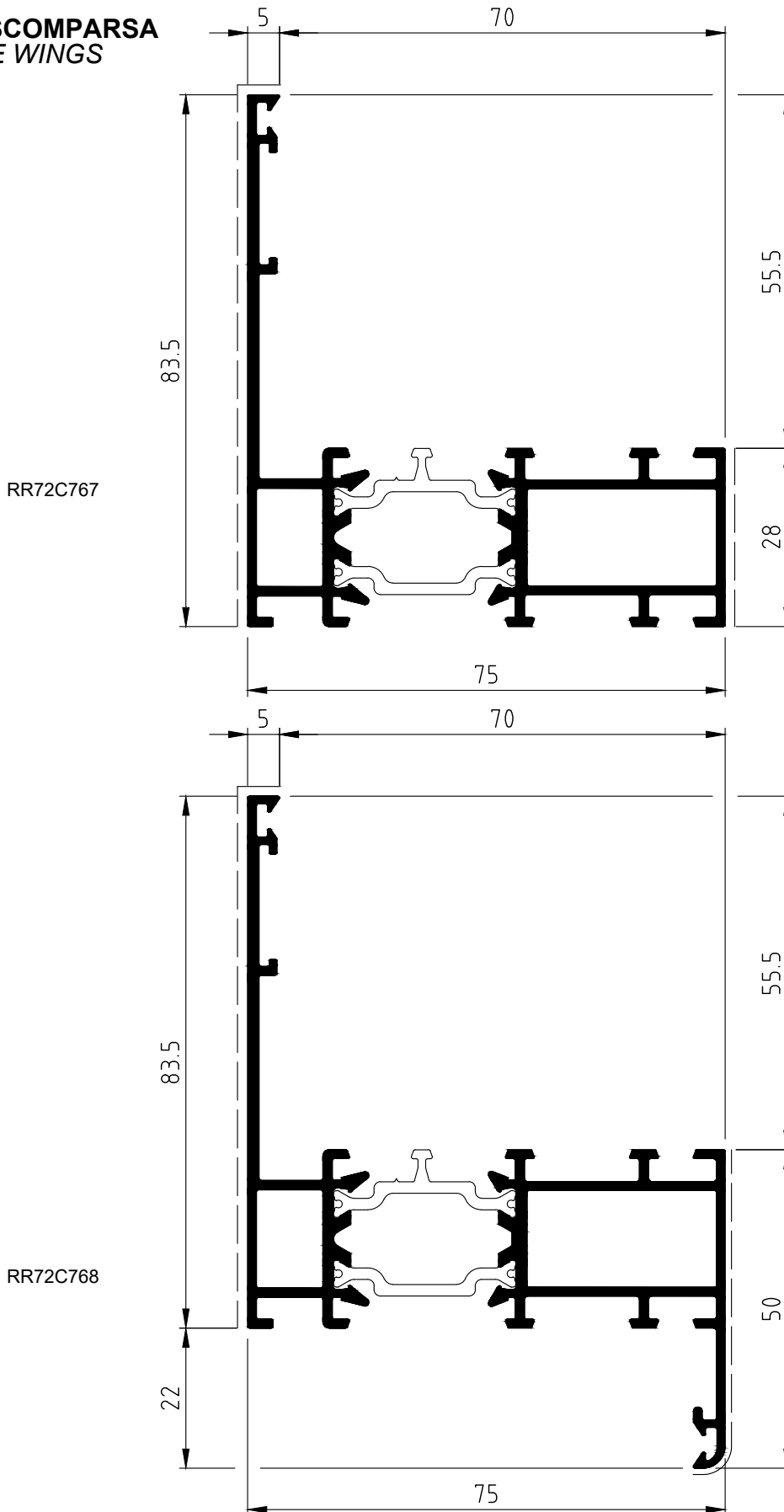

ANTE A SCOMPARSA
INVISIBLE WINGS

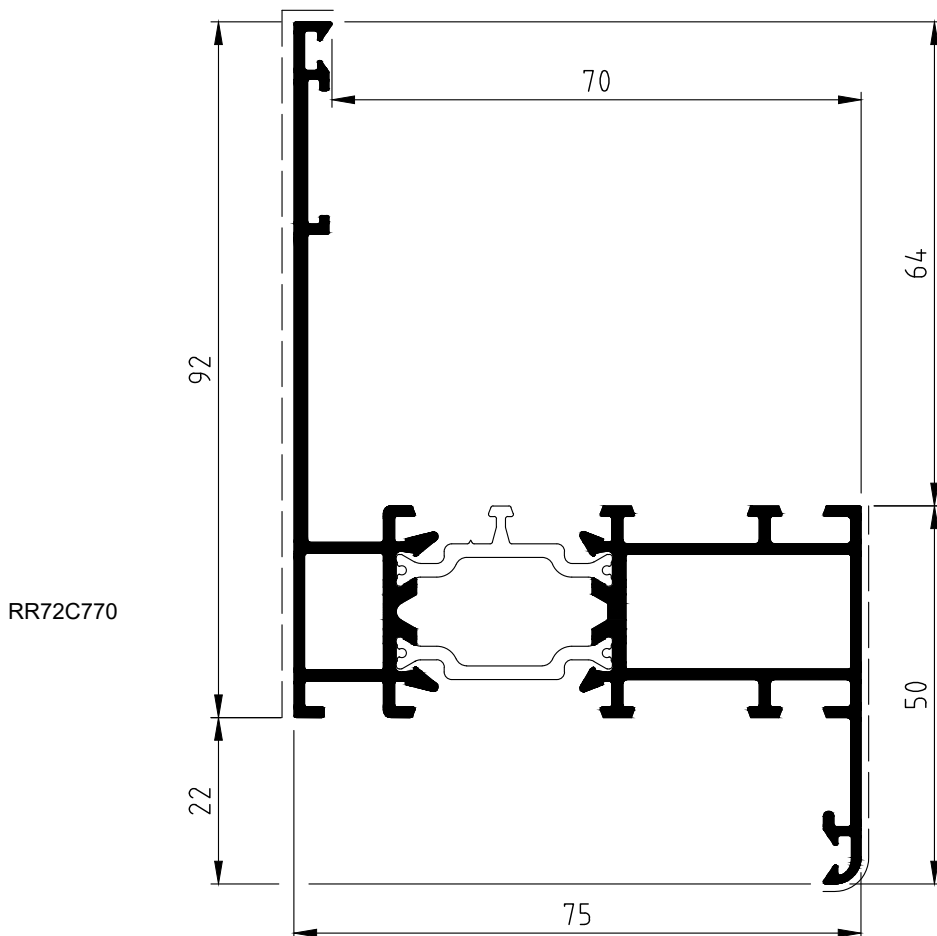
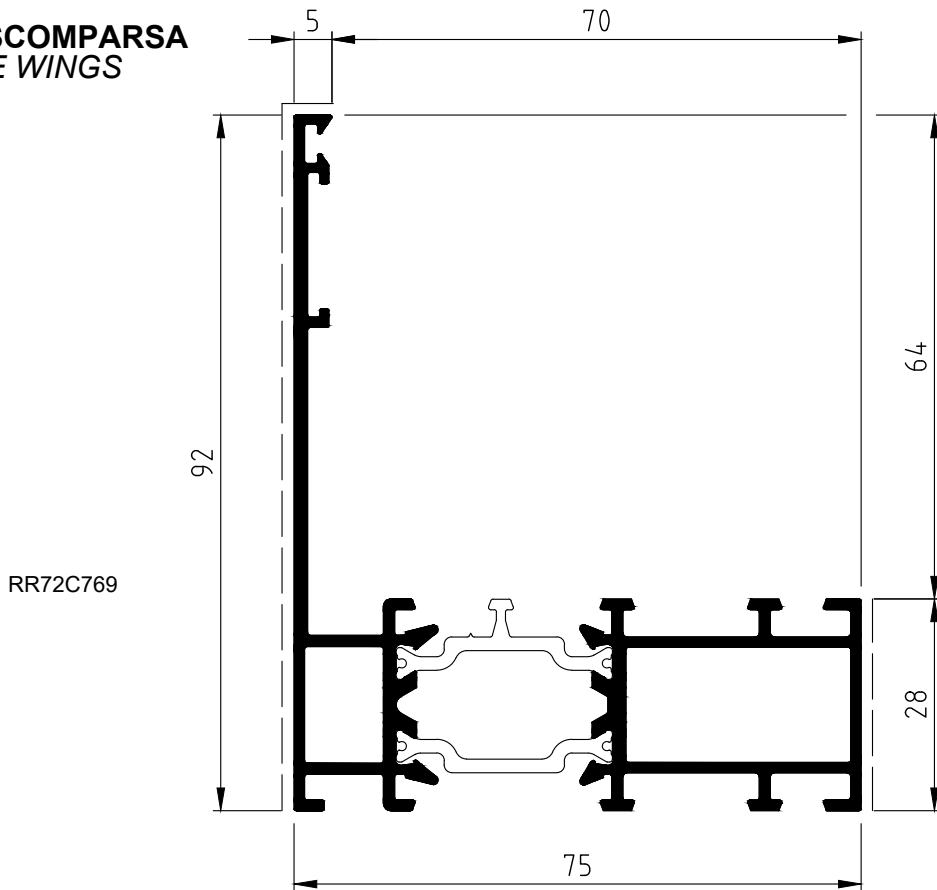

ANTE A SCOMPARSA
INVISIBLE WINGS

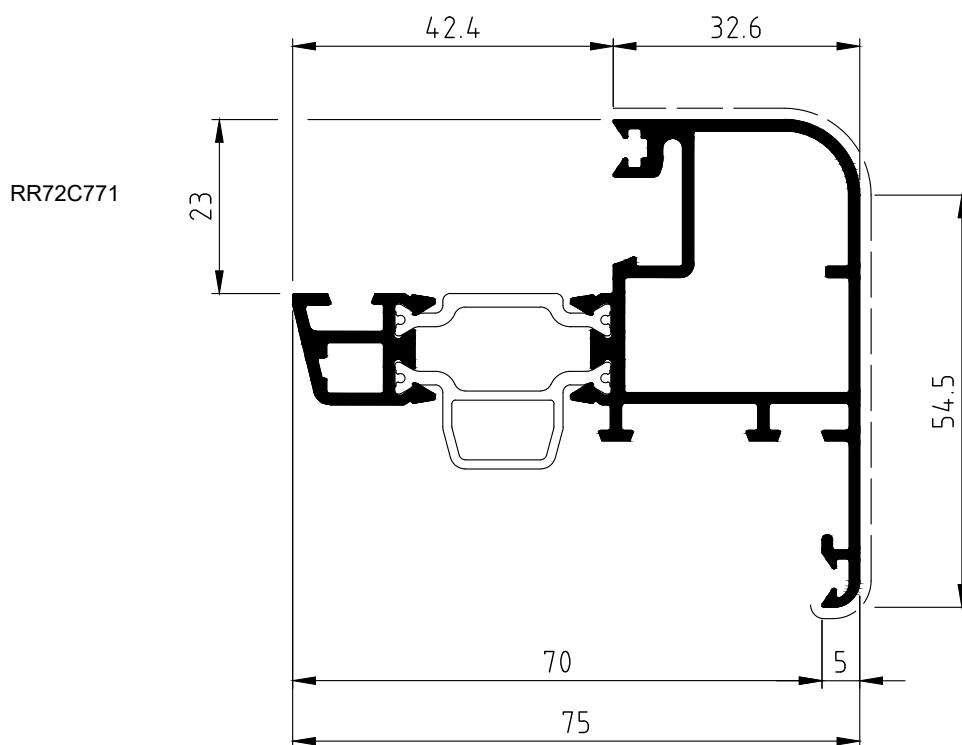

**VARI
SUNDRIES**

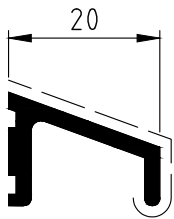

R2100009

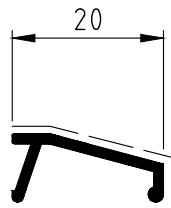

R2100342

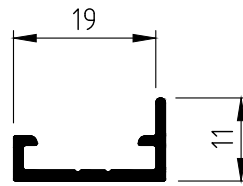

R1F14042

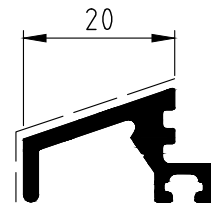

R2900390

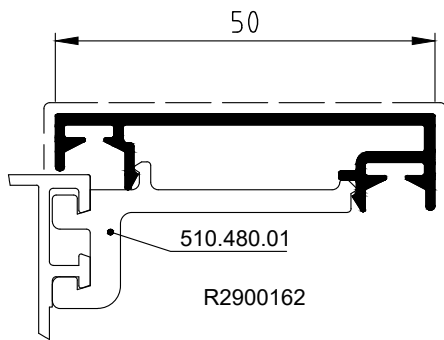

R2900162

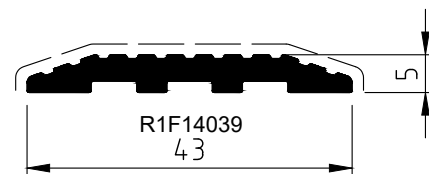

R1F14039
43

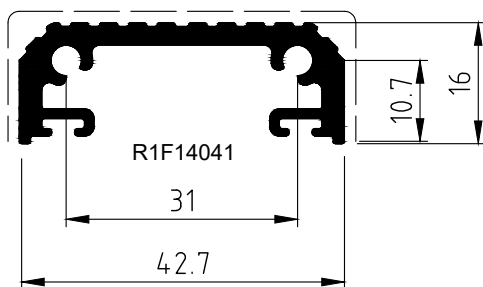

R1F14041

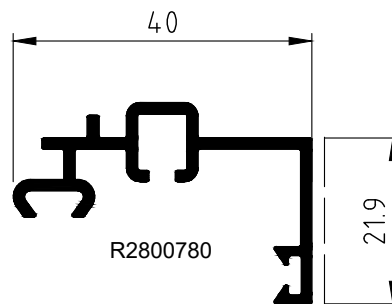

R2800780

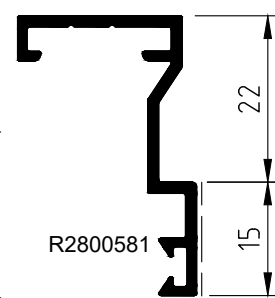

R2800581

**VARI
SUNDRIES**

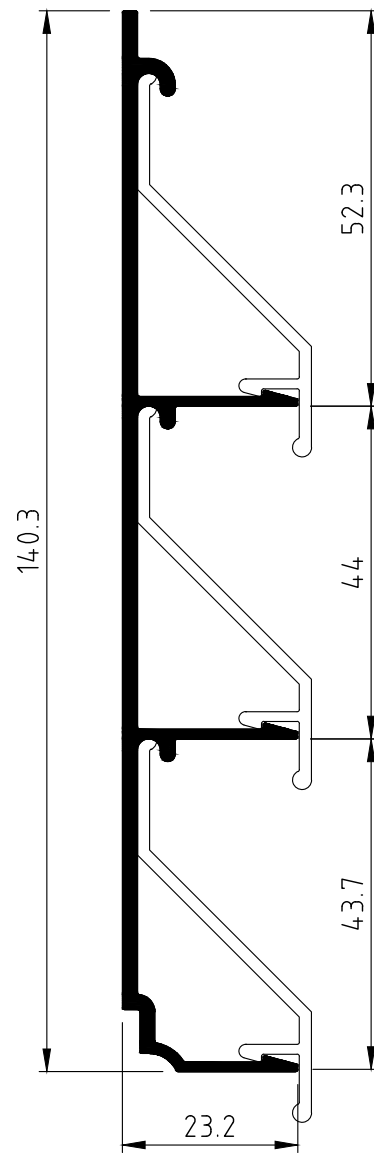
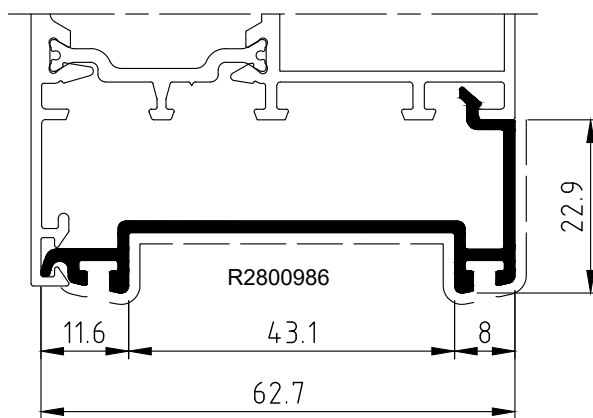
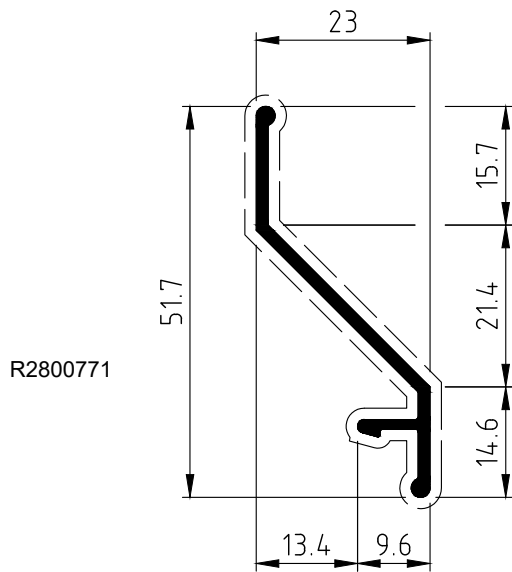

**ASTA
BAR**

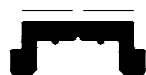

R2900221

Lunghezza Standard Barre = 6500 mm
Standard lenght = 6500 mm

DOGA
STAVE

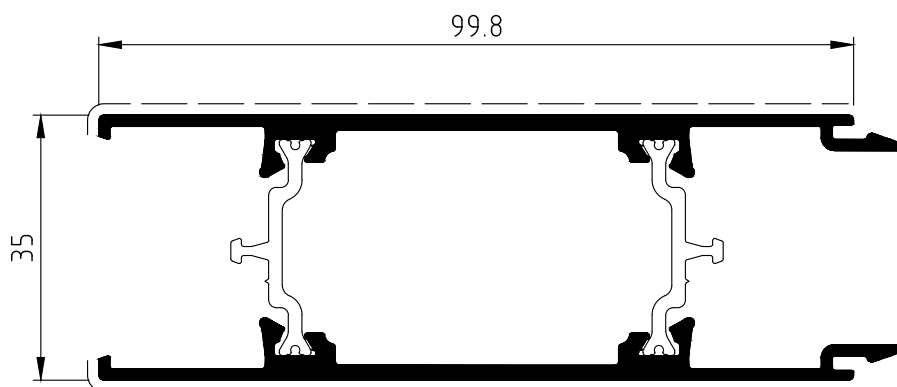

RR72C718

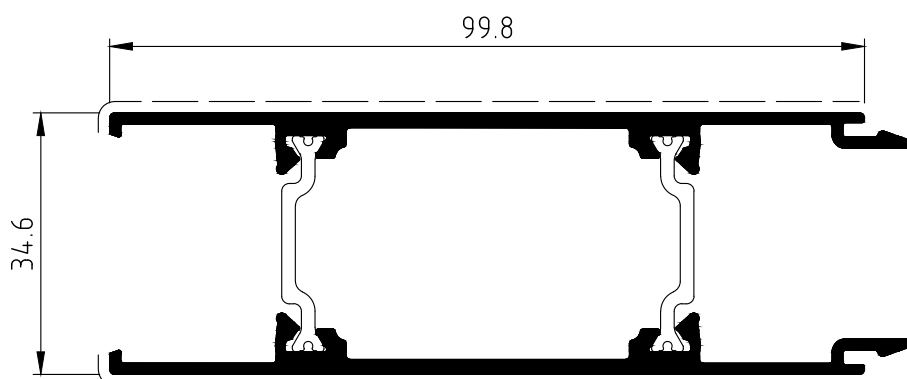

RR72C757

SEZIONI
SECTIONS

FINESTRA A DUE ANTE
TWO WING WINDOW

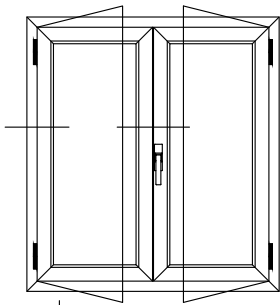

(*) Negli angoli a 45° le squadrette inserite nel tubolare esterno devono essere sempre incollate e cianfrinate.
Cianfrinatura eseguibile anche con attrezzatura manuale Cod. M.2001.OO
In the 45° corners, the corner joints in the external tubular section, must always be glued and caulked. Caulking may also be carried out by hand with equipment Art.M.2001.OO

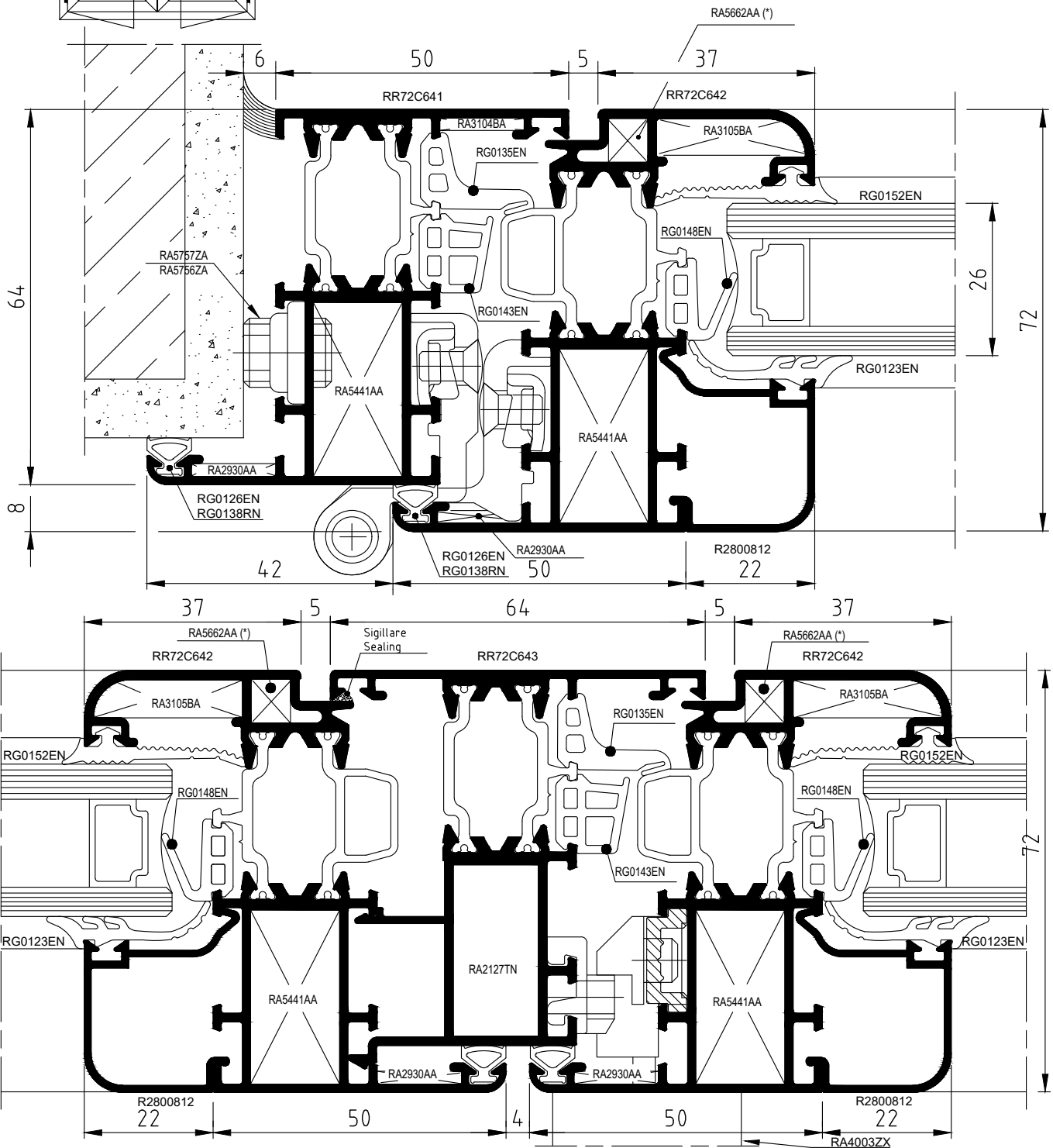

FINESTRA A TRE ANTE
THREE - WING WINDOW

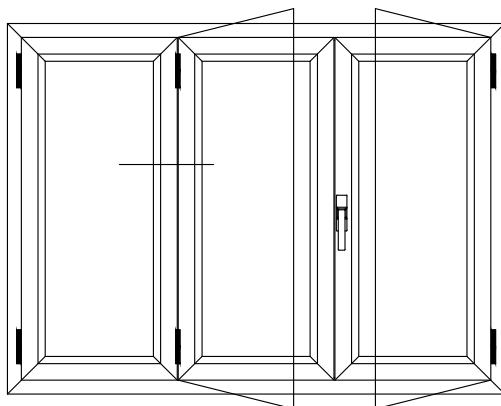

(*) Negli angoli a 45° le squadrette inserite nel tubolare esterno devono essere sempre incollate e cianfrinate.
Cianfrinatura eseguibile anche con attrezzatura manuale Cod. M.2001.OO
In the 45° corners, the corner joints in the external tubular section, must always be glued and caulked. Caulking may also be carried out by hand with equipment Art.M.2001.OO

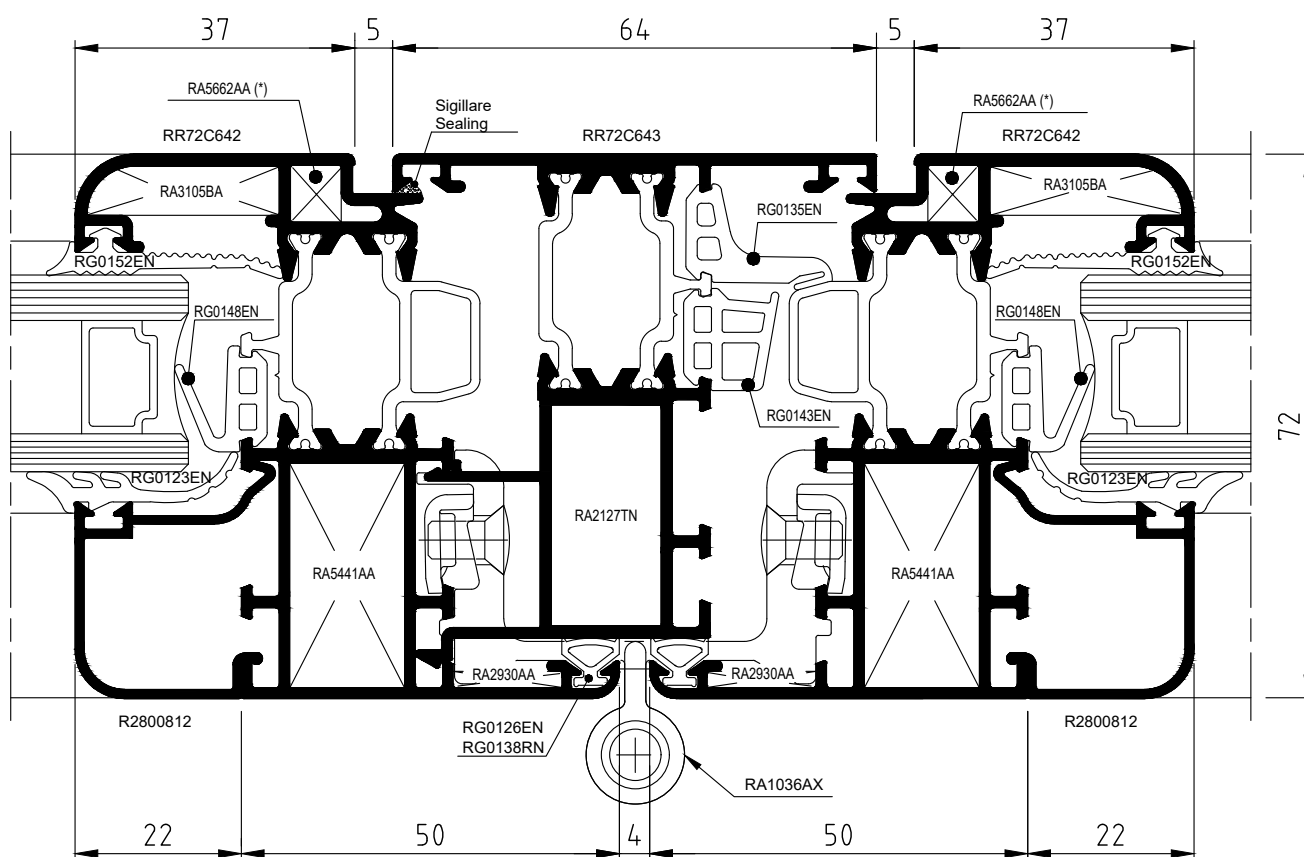

**FINESTRA
WINDOW**

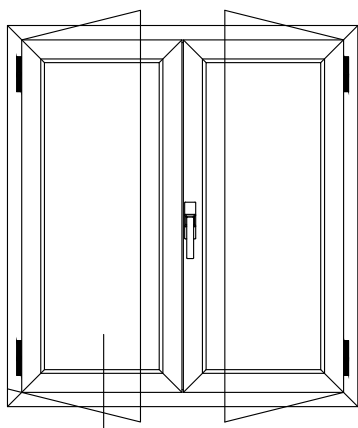

(*) Negli angoli a 45° le squadrette inserite nel tubolare esterno devono essere sempre incollate e cianfrinate.
Cianfrinatura eseguibile anche con attrezzatura manuale Cod. M.2001.OO
In the 45° corners, the corner joints in the external tubular section, must always be glued and caulked. Caulking may also be carried out by hand with equipment Art.M.2001.OO

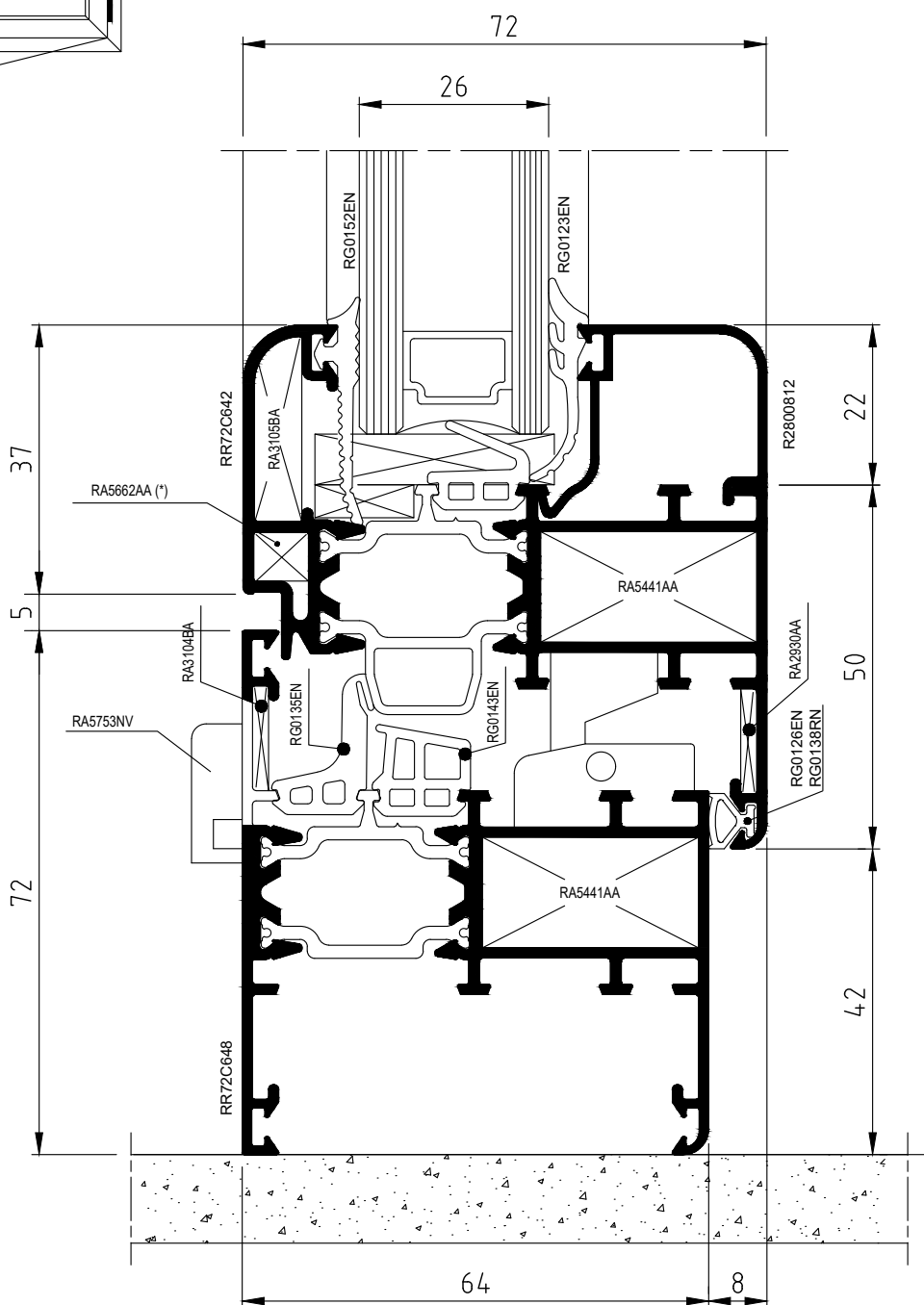

PORTA BALCONE
BALCONY DOOR

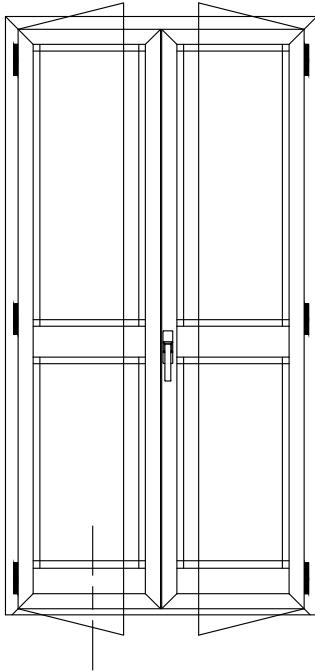

(*) Negli angoli a 45° le squadrette inserite nel tubolare esterno devono essere sempre incollate e cianfrinate.
Cianfrinatura eseguibile anche con attrezzatura manuale Cod. M.2001.OO
In the 45° corners, the corner joints in the external tubular section, must always be glued and caulked. Caulking may also be carried out by hand with equipment Art.M.2001.OO

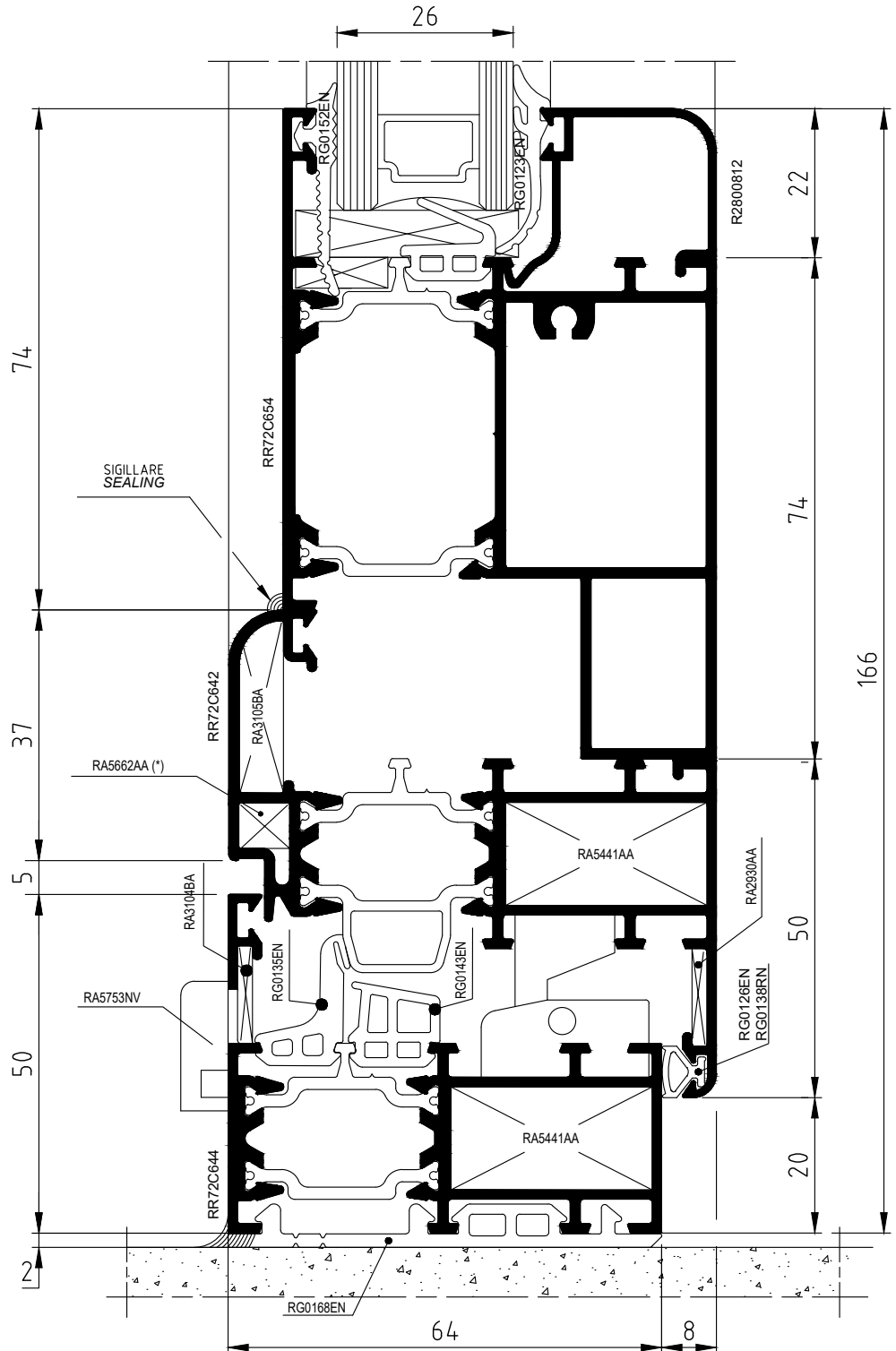

FINESTRA A DUE ANTE CON PROF. RR72C673
TWO WING WINDOW WITH RR72C673

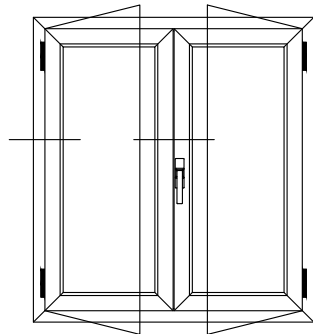

(*) Negli angoli a 45° le squadrette inserite nel tubolare esterno devono essere sempre incollate e cianfrinate.
Cianfrinatura eseguibile anche con attrezzatura manuale Cod. M.2001.OO
In the 45° corners, the corner joints in the external tubular section, must always be glued and caulked. Caulking may also be carried out by hand with equipment Art.M.2001.OO

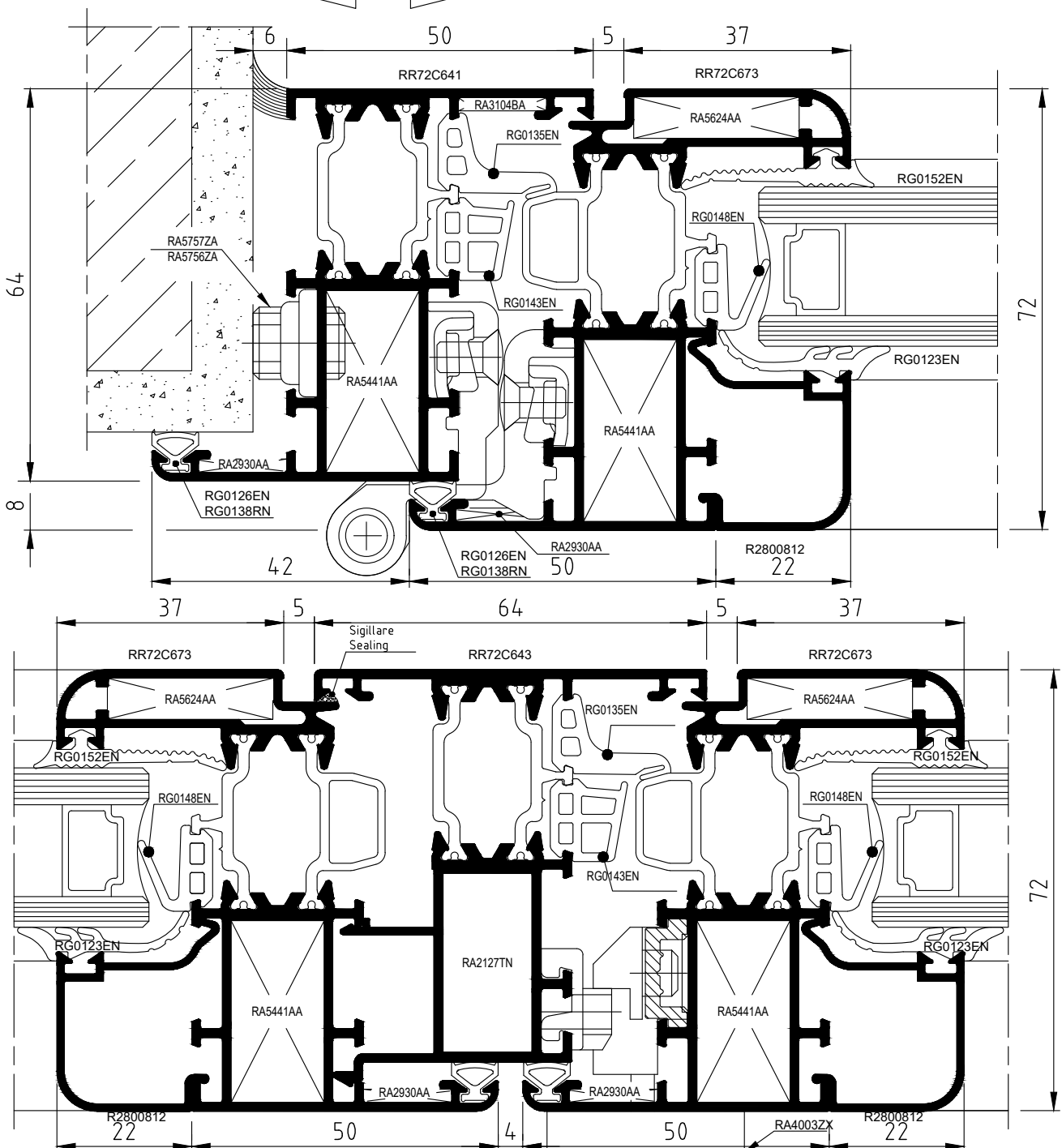

FINESTRA A DUE ANTE CON PROF. RR72C675-RR72C745
TWO WING WINDOW WITH RR72C675 AND RR72C745

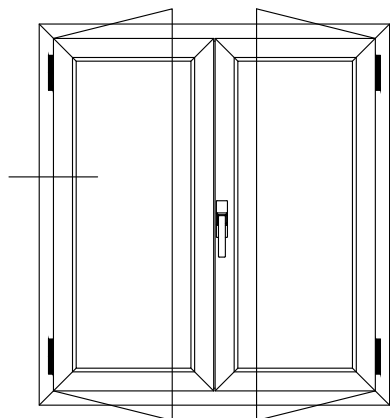

(*) Negli angoli a 45° le squadrette inserite nel tubolare esterno devono essere sempre incollate e cianfrinate.
Cianfrinatura eseguibile anche con attrezzatura manuale Cod. M.2001.OO
In the 45° corners, the corner joints in the external tubular section, must always be glued and caulked. Caulking may also be carried out by hand with equipment Art.M.2001.OO

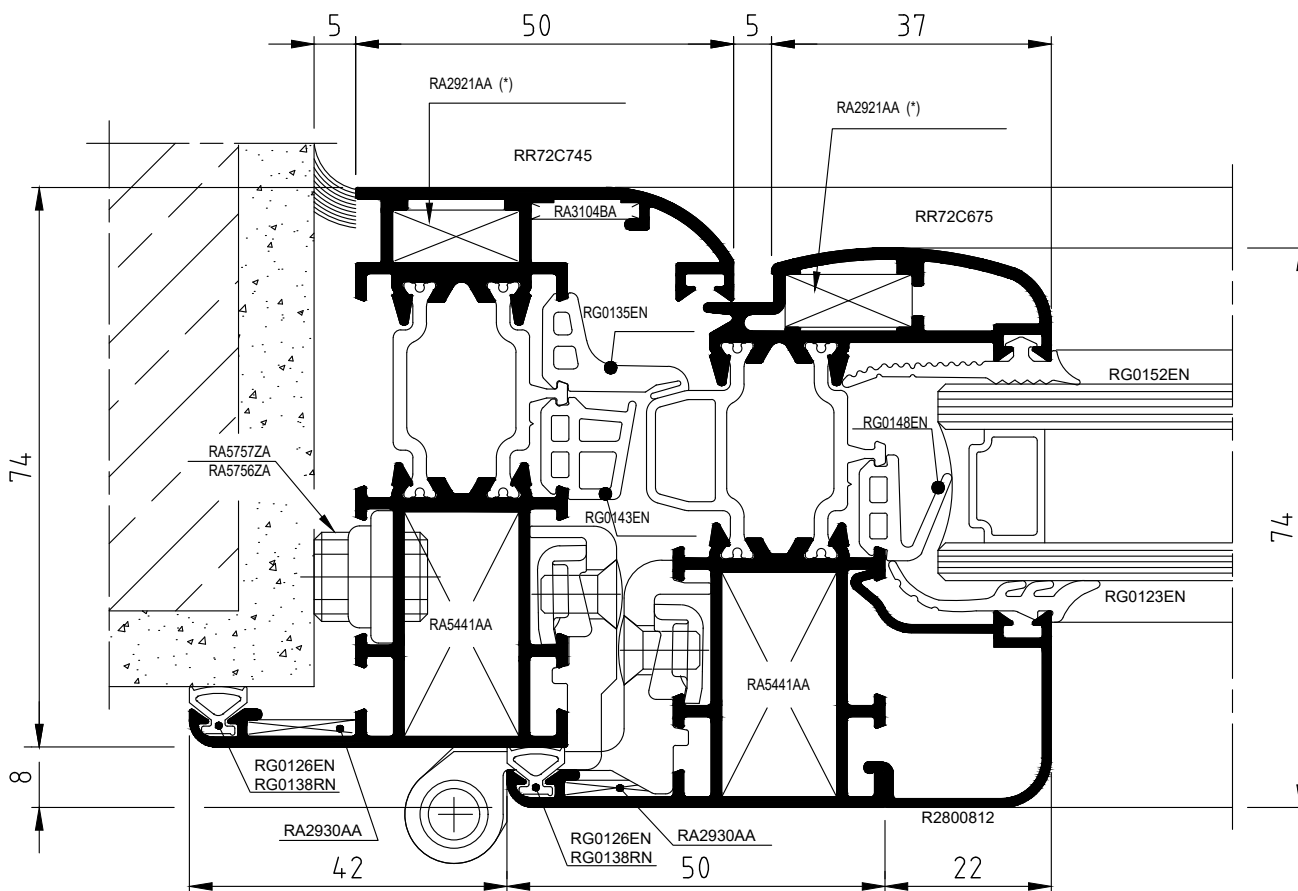

FINESTRA A DUE ANTE CON PROF. RR72C675-RR72C676
TWO WING WINDOW WITH RR72C675 AND RR72C676

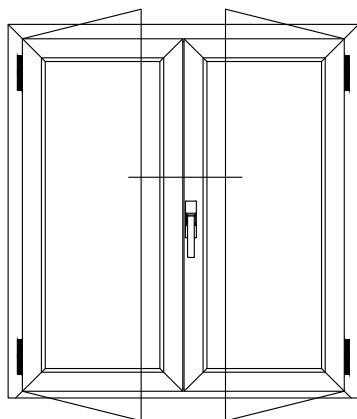

(*) Negli angoli a 45° le squadrette inserite nel tubolare esterno devono essere sempre incollate e cianfrinate.
Cianfrinatura eseguibile anche con attrezzatura manuale Cod. M.2001.OO
In the 45° corners, the corner joints in the external tubular section, must always be glued and caulked. Caulking may also be carried out by hand with equipment Art.M.2001.OO

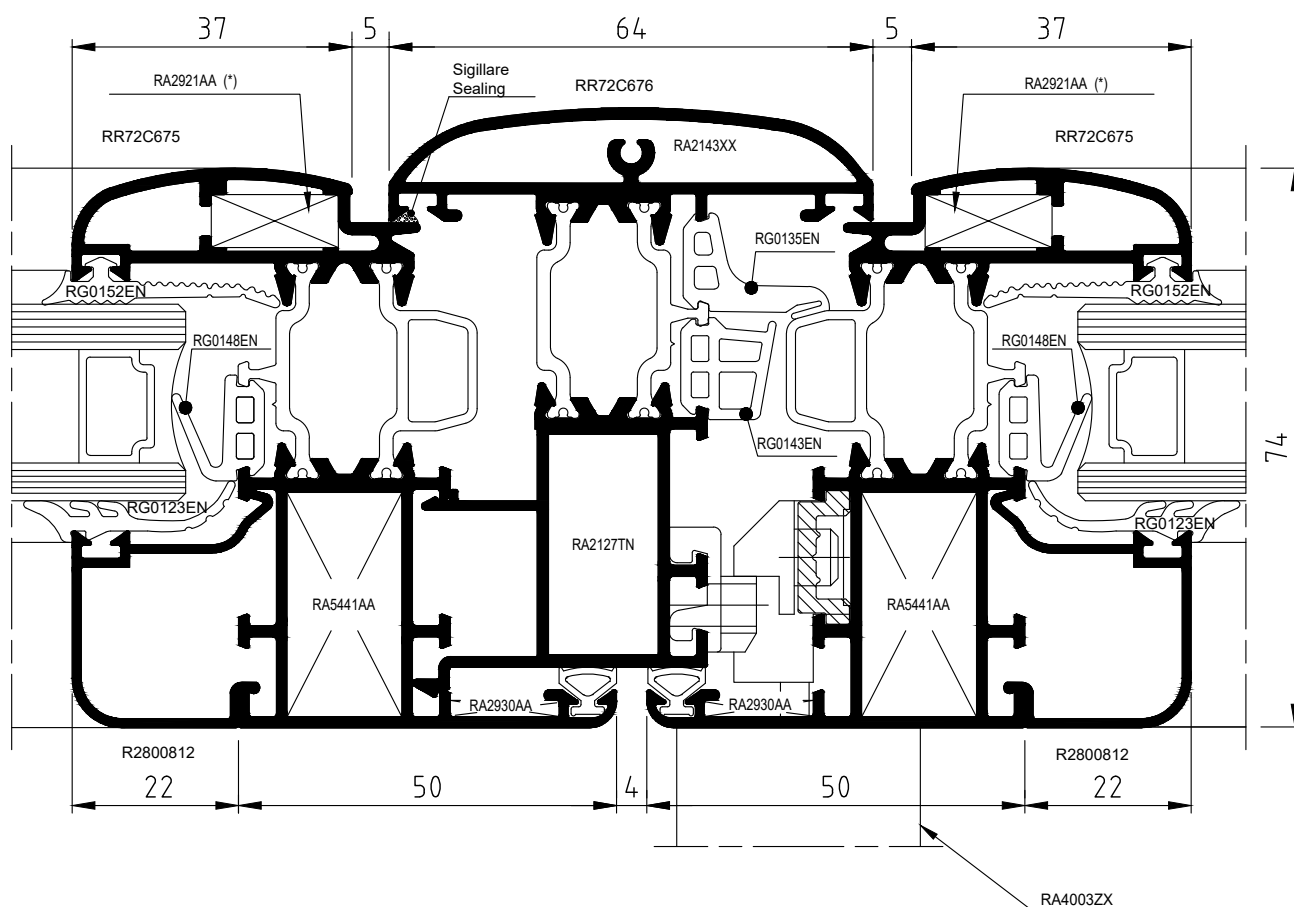

FINESTRA A DUE ANTE
TWO WING WINDOW

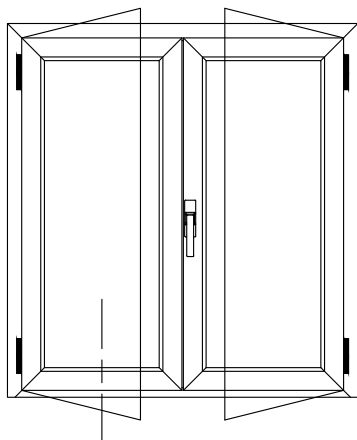

(*) Negli angoli a 45° le squadrette inserite nel tubolare esterno devono essere sempre incollate e cianfrinate.
Cianfrinatura eseguibile anche con attrezzatura manuale Cod. M.2001.OO
In the 45° corners, the corner joints in the external tubular section, must always be glued and caulked. Caulking may also be carried out by hand with equipment Art.M.2001.OO

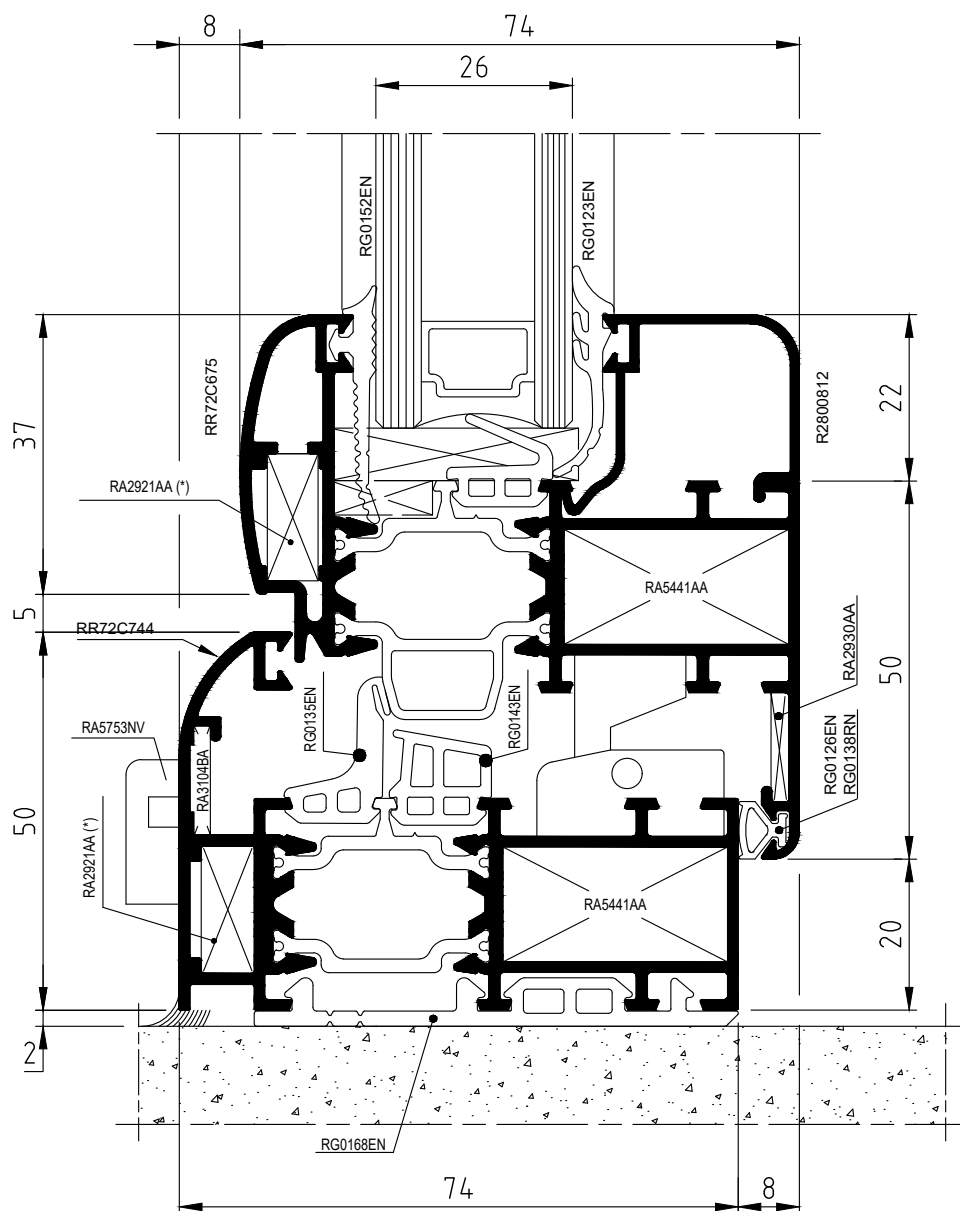

PORTA BALCONE
BALCONY DOOR

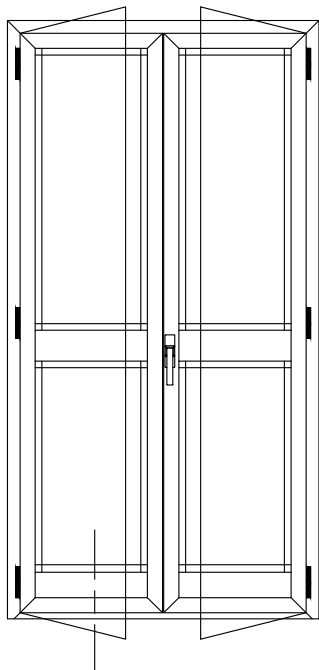

(*) Negli angoli a 45° le squadrette inserite nel tubolare esterno devono essere sempre incollate e cianfrinate.
Cianfrinatura eseguibile anche con attrezzatura manuale Cod. M.2001.OO
In the 45° corners, the corner joints in the external tubular section, must always be glued and caulked. Caulking may also be carried out by hand with equipment Art.M.2001.OO

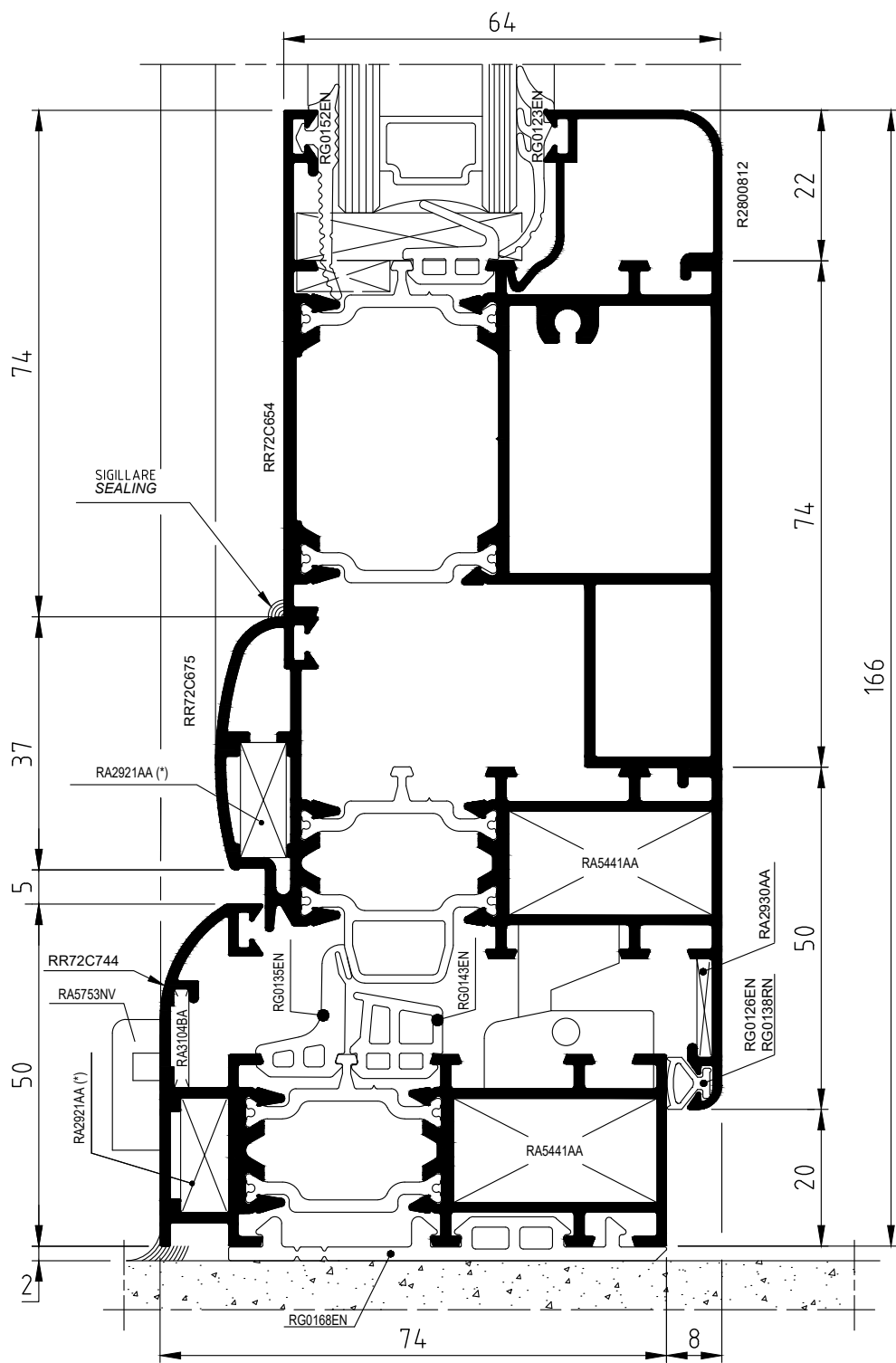

FINESTRA A DUE ANTE
TWO WING WINDOW

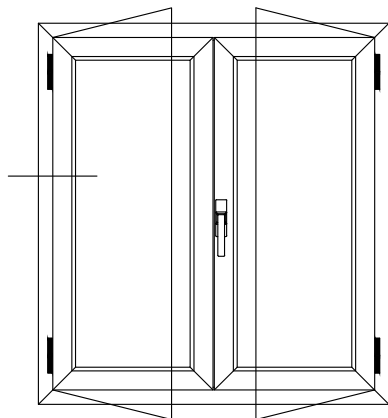

(*) Negli angoli a 45° le squadrette inserite nel tubolare esterno devono essere sempre incollate e cianfrinate.
Cianfrinatura eseguibile anche con attrezzatura manuale Cod. M.2001.OO
In the 45° corners, the corner joints in the external tubular section, must always be glued and caulked. Caulking may also be carried out by hand with equipment Art.M.2001.OO

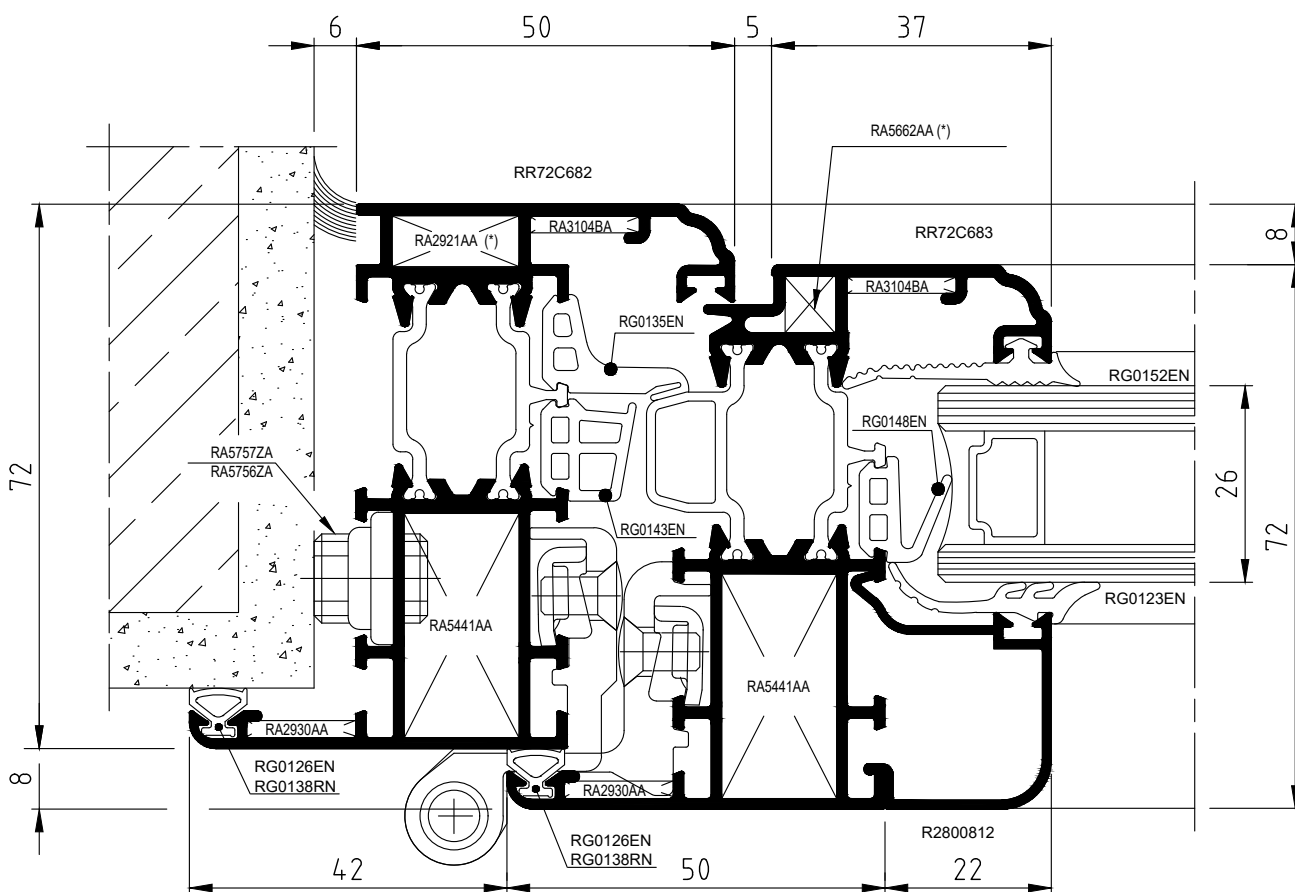

FINESTRA A DUE ANTE
TWO WING WINDOW

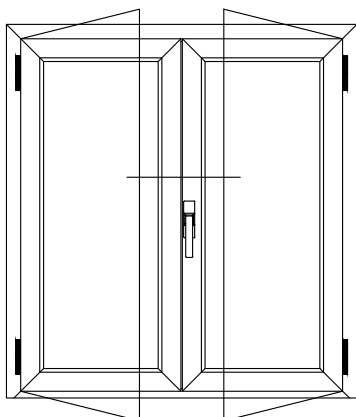

(*) Negli angoli a 45° le squadrette inserite nel tubolare esterno devono essere sempre incollate e cianfrinate.
Cianfrinatura eseguibile anche con attrezzatura manuale Cod. M.2001.OO
In the 45° corners, the corner joints in the external tubular section, must always be glued and caulked. Caulking may also be carried out by hand with equipment Art.M.2001.OO

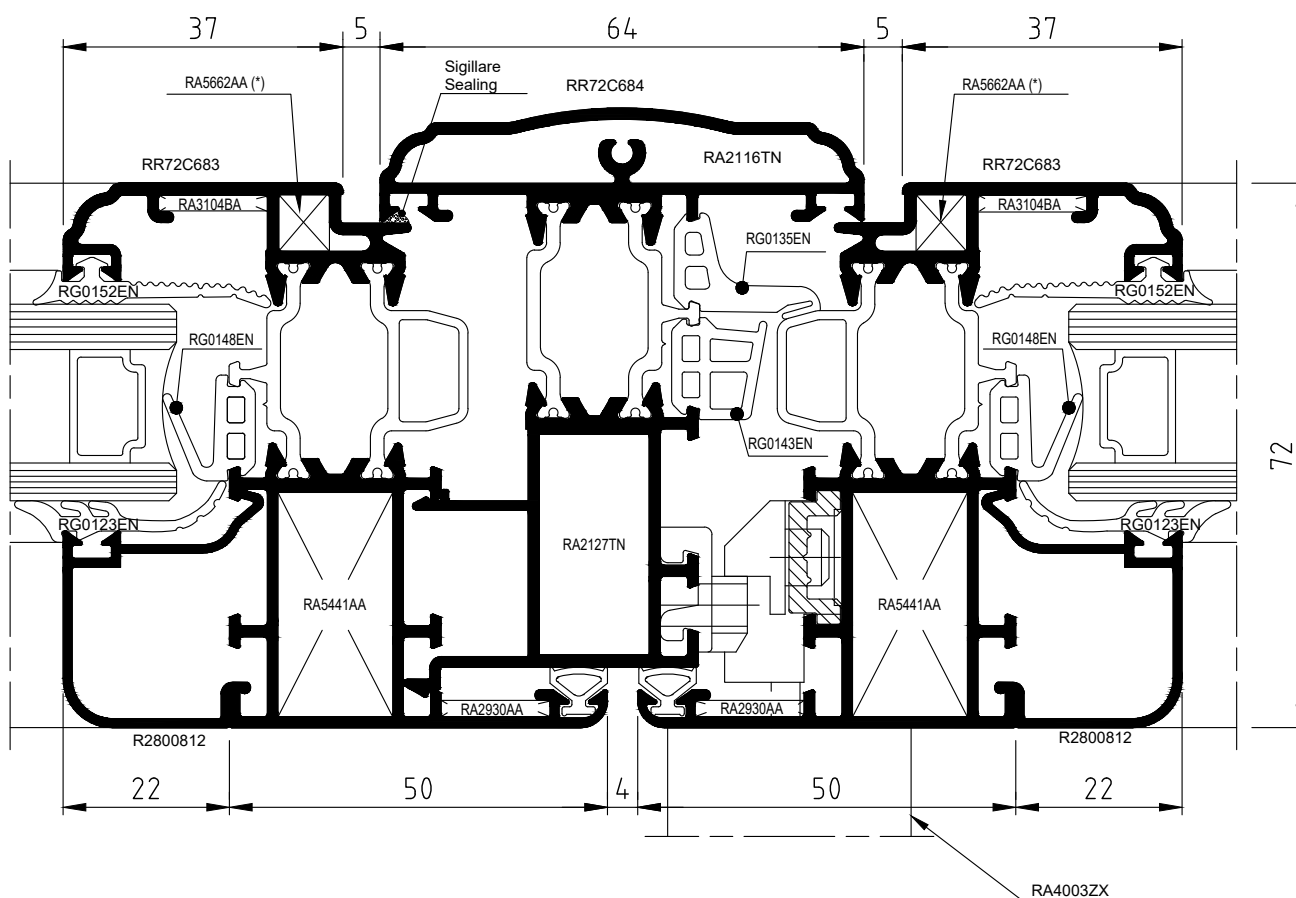

TELAI CON PROFILI TELESCOPICI
FRAMES WITH TELESCOPIC SECTIONS

(*) Negli angoli a 45° le squadrette inserite nel tubolare esterno devono essere sempre incollate e cianfrinate. Cianfrinatura eseguibile anche con attrezzatura manuale Cod. M.2001.OO
In the 45° corners, the corner joints in the external tubular section, must always be glued and caulked. Caulking may also be carried out by hand with equipment Art.M.2001.OO

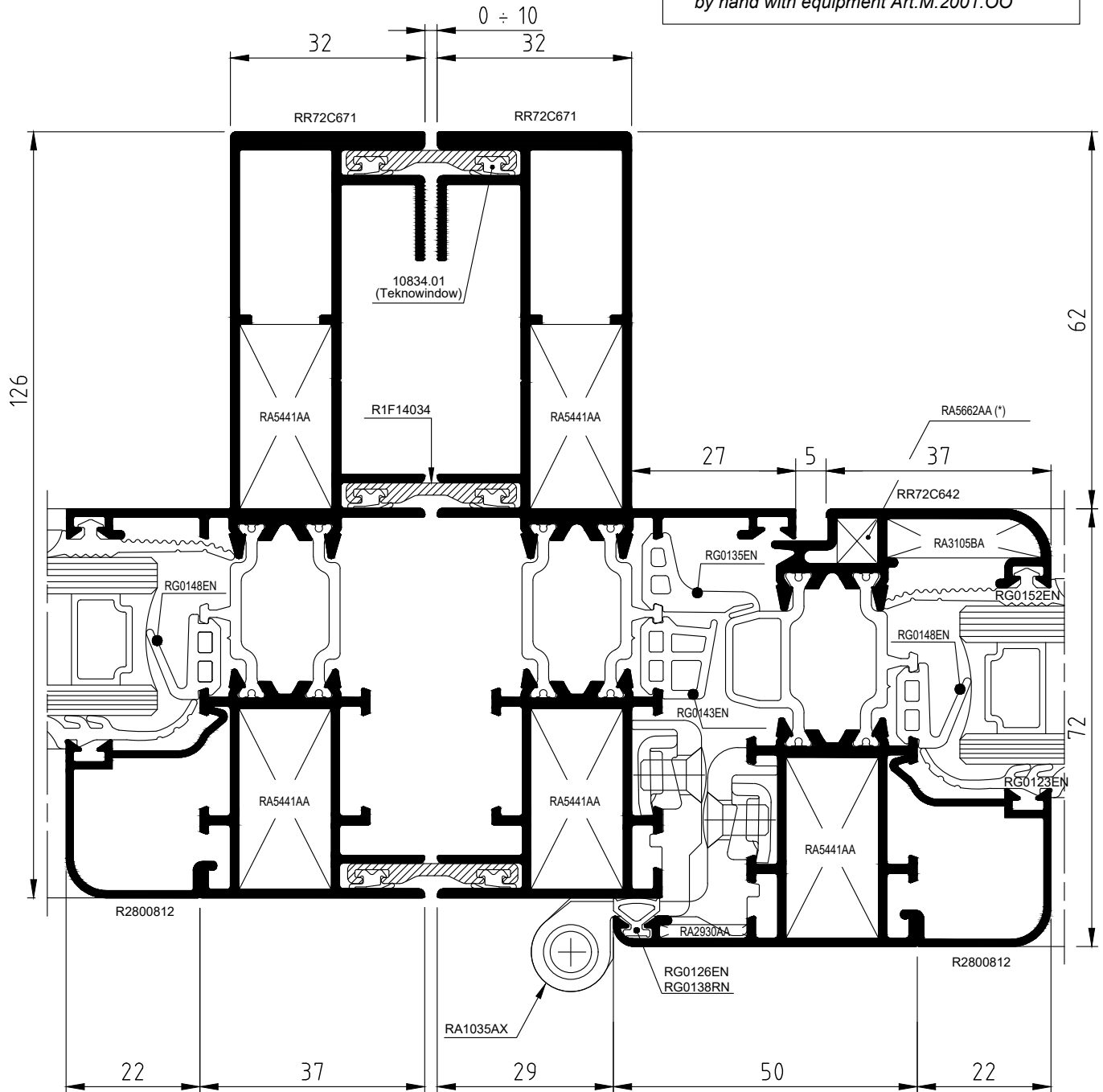

PORTA BALCONE
BALCONY DOOR

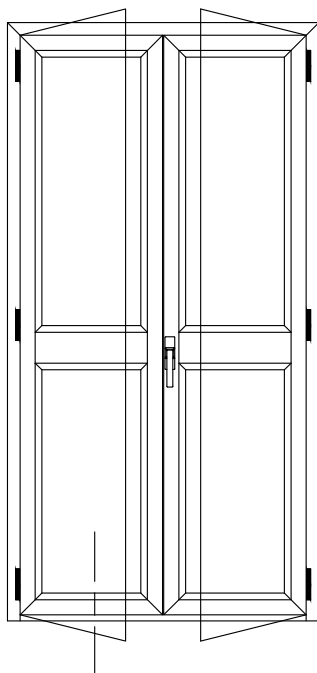

(*) Negli angoli a 45° le squadrette inserite nel tubolare esterno devono essere sempre incollate e cianfrinate. Cianfrinatura eseguibile anche con attrezzatura manuale Cod. M.2001.OO
In the 45° corners, the corner joints in the external tubular section, must always be glued and caulked. Caulking may also be carried out by hand with equipment Art.M.2001.OO

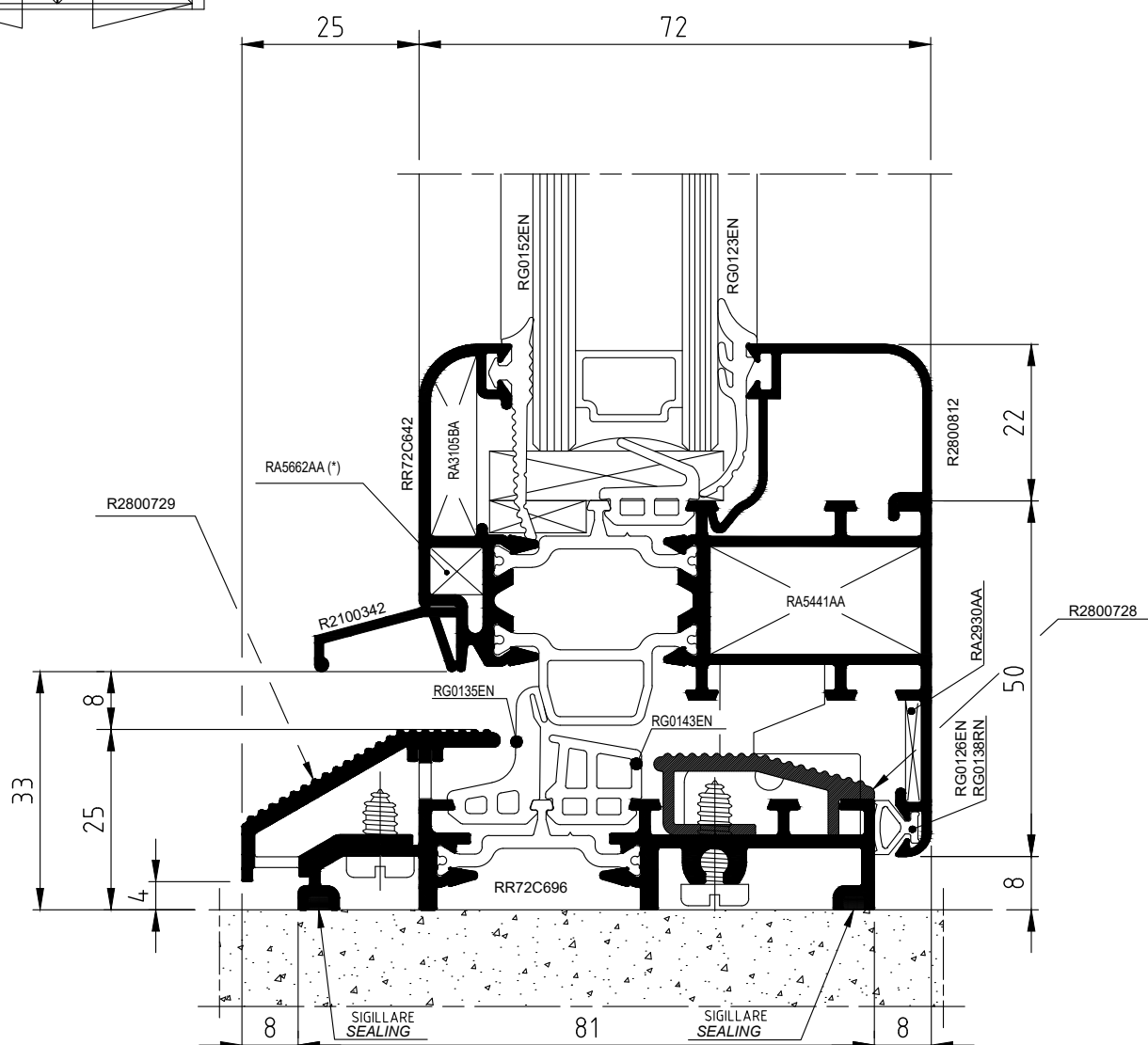

SPORGERE
PROJECTING WINDOW

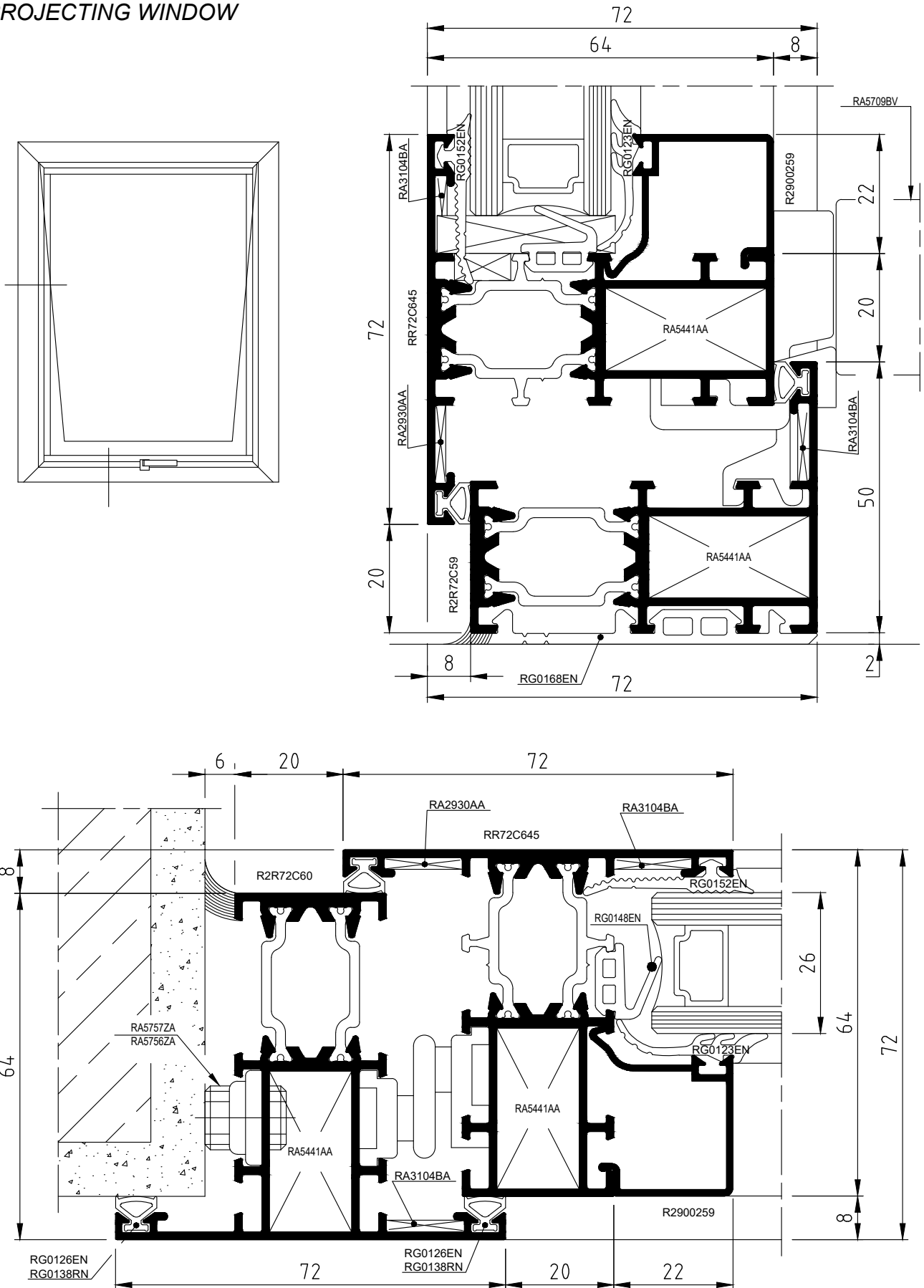

**TELAIO SPECIALE
SPECIAL FRAME**

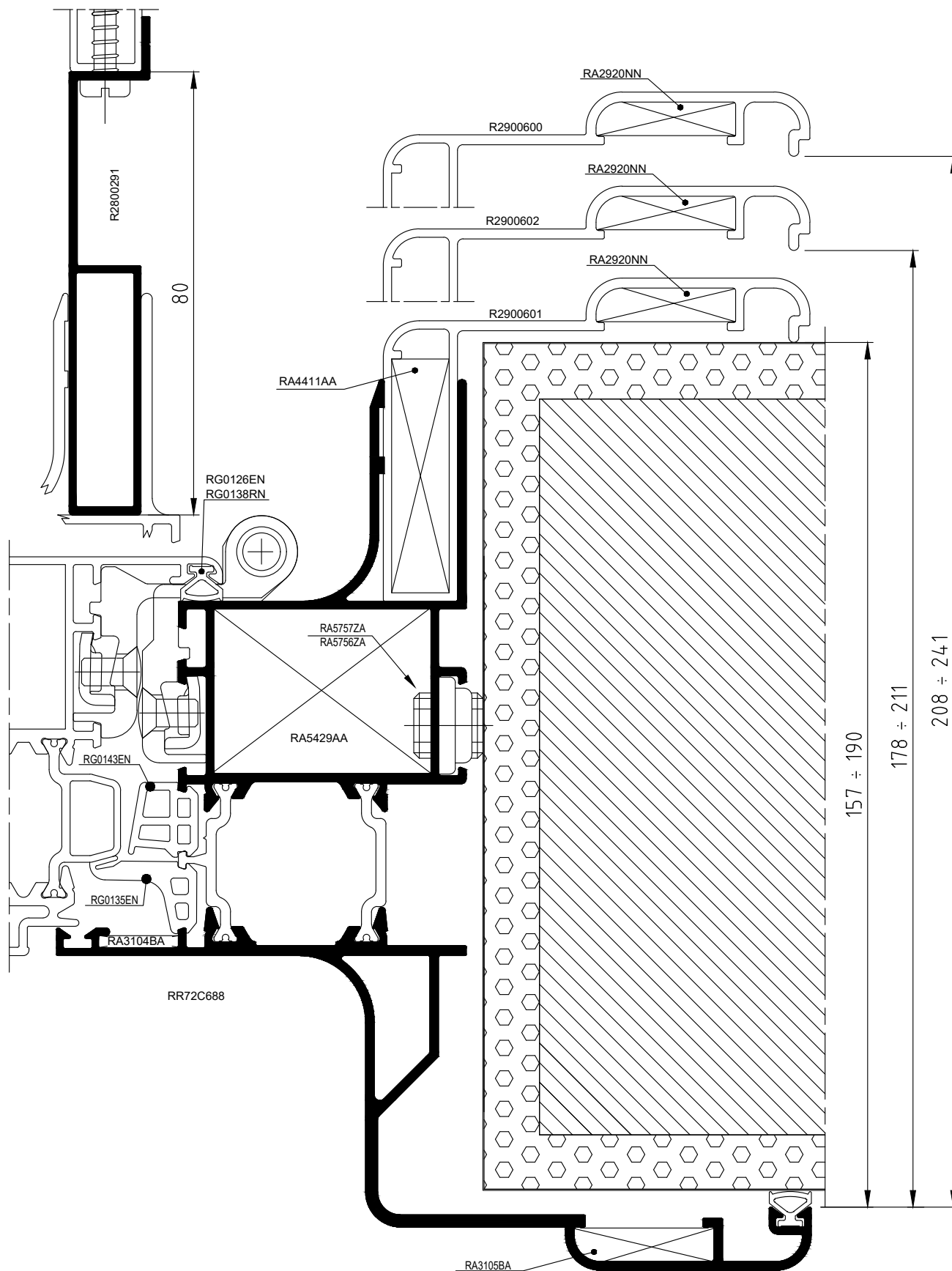

**TELAIO SPECIALE
SPECIAL FRAME**

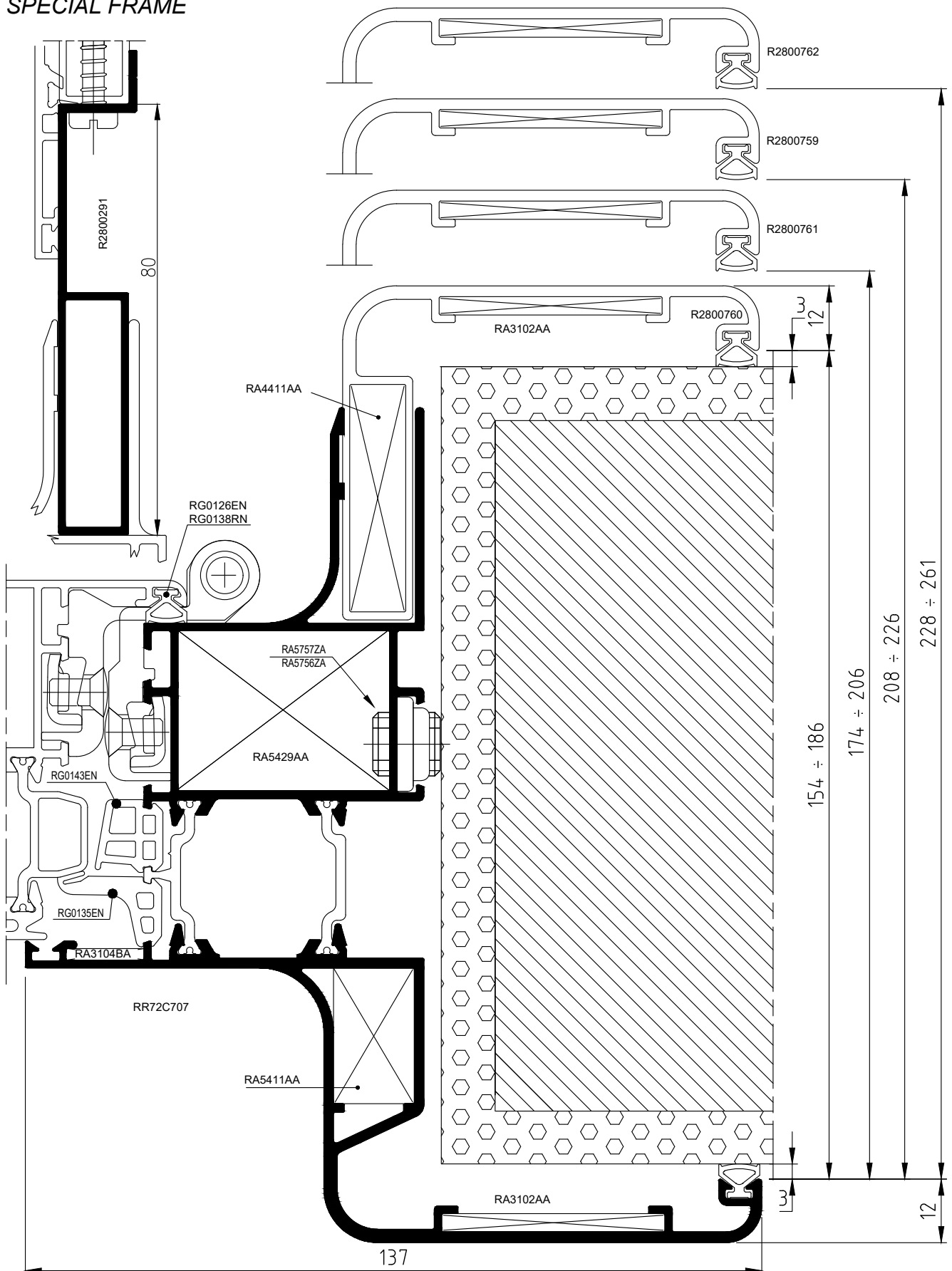

**TELAIO SPECIALE
SPECIAL FRAME**

Profilati Sections		Spessore Muro Wall Thickness
Ester.	Inter.	mm
R2800760	R2800760	x= 165+231
R2800760	R2800761	x= 185+251
R2800760	R2800759	x= 219+269
R2800760	R2800762	x= 240+306
R2800761	R2800760	x= 185+243
R2800761	R2800761	x= 205+271
R2800761	R2800759	x= 239+289
R2800761	R2800762	x= 260+326
R2800759	R2800760	x= 219+269
R2800759	R2800761	x= 239+289
R2800759	R2800759	x= 274+309
R2800759	R2800762	x= 294+344
R2800762	R2800760	x= 240+306
R2800762	R2800761	x= 260+326
R2800762	R2800759	x= 294+344
R2800762	R2800762	x= 315+381

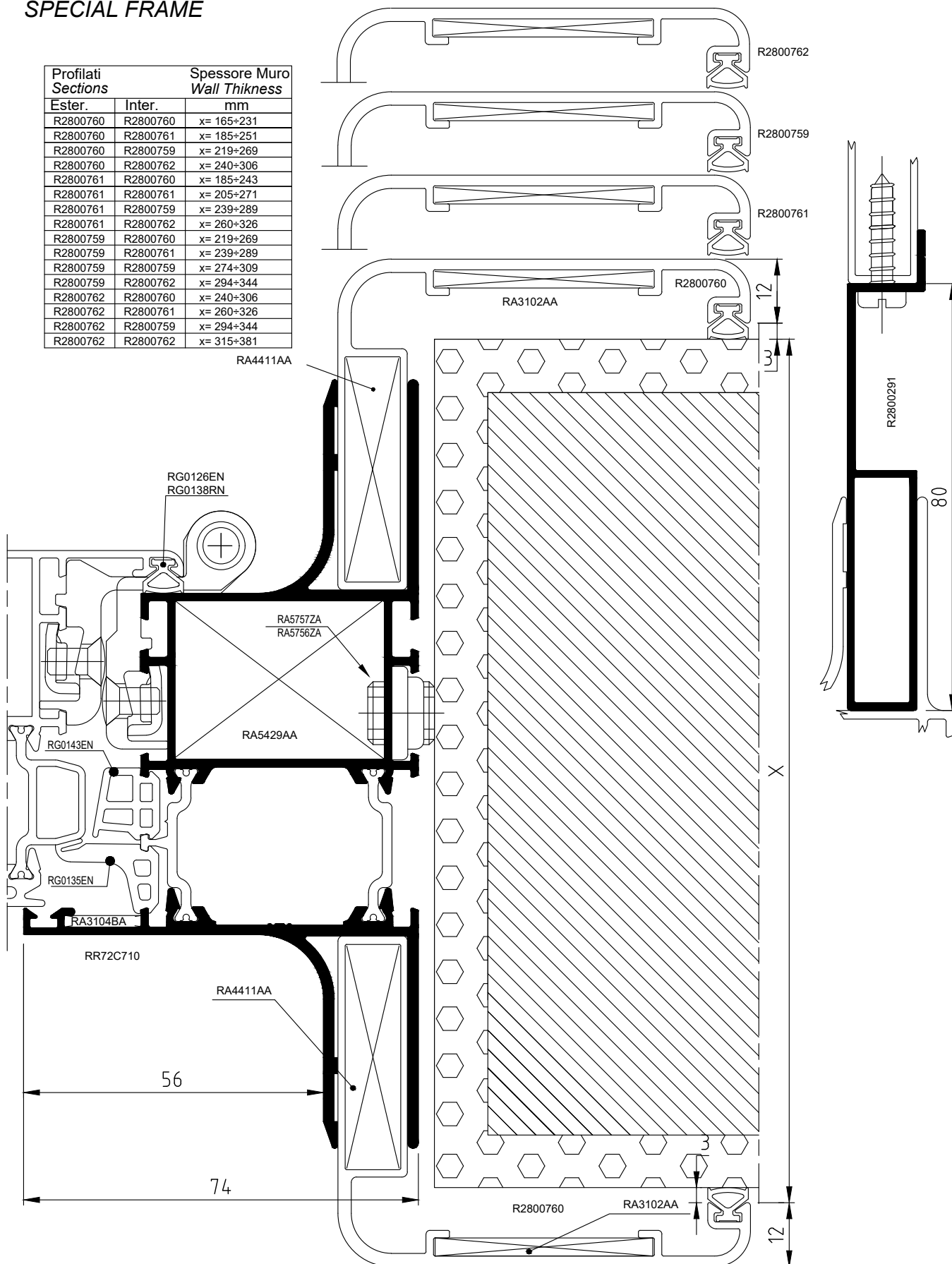

APPLICAZIONE SOGLIA E PORTAGUARNIZIONE SOTTOZOCOLO
APPLICATION THRESHOLD AND SKIRTING BOARD WEATHERSTRIP HOLDER

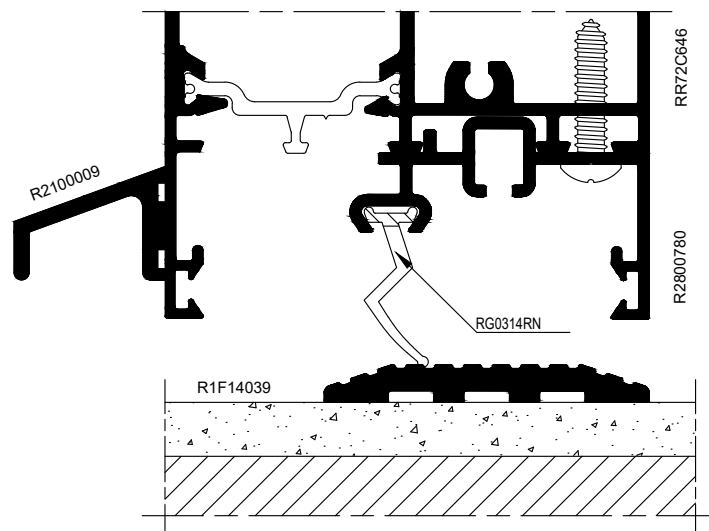
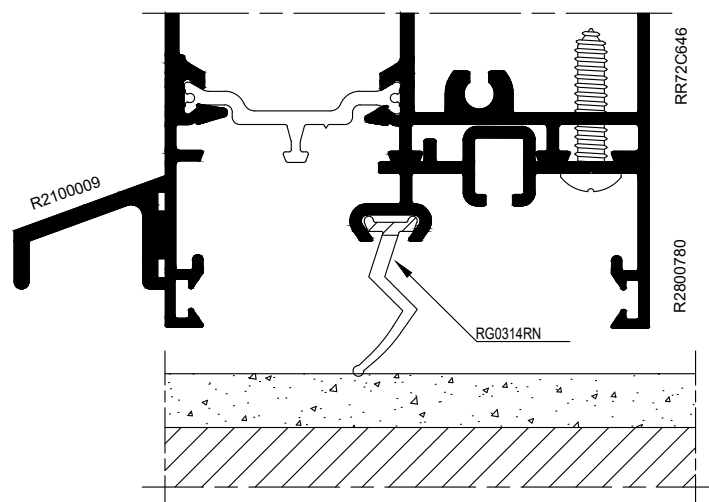
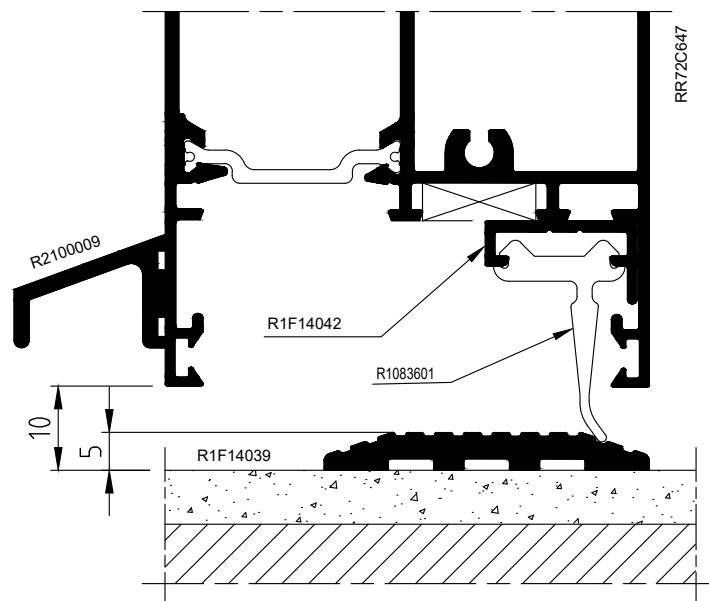

APPLICAZIONE SOGLIA E PORTAGUARNIZIONE SOTTOZOCOLO
APPLICATION THRESHOLD AND SKIRTING BOARD WEATHERSTRIP HOLDER

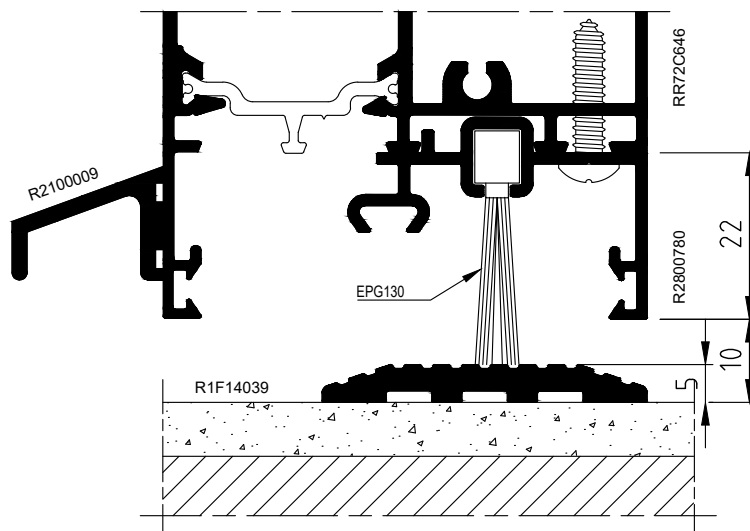
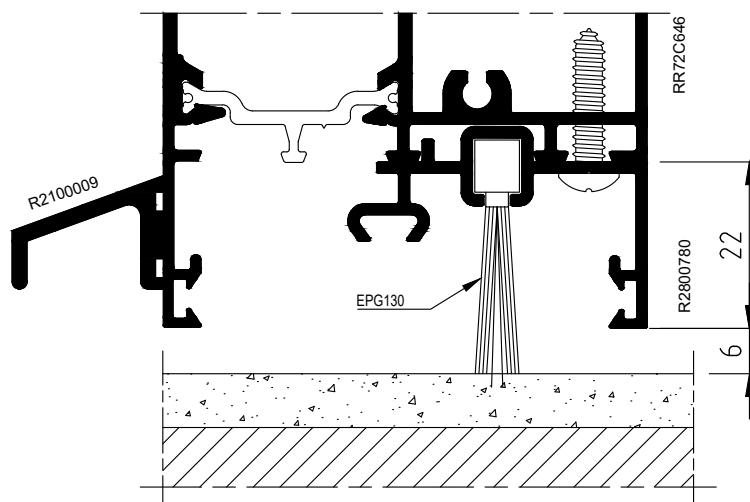
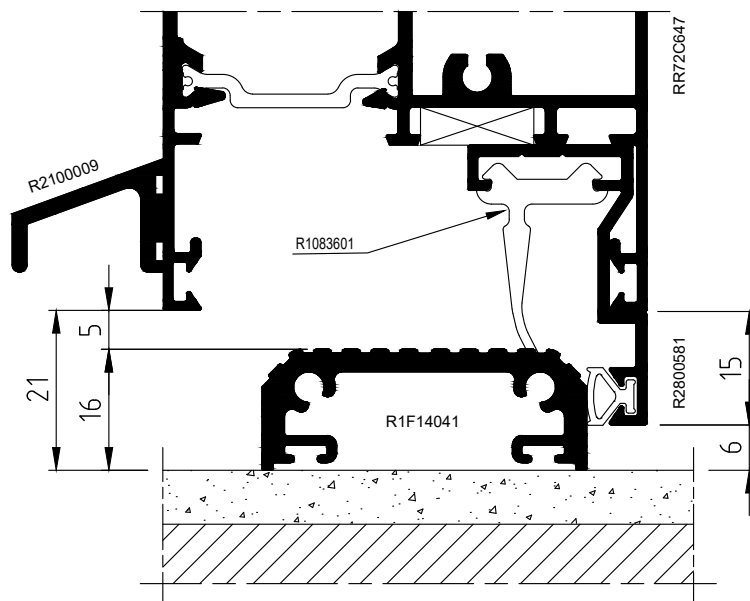

FISSAGGI ALLA MURATURA CON COMPENSATORI
FIXING TO WALL WITH COMPENSATORS

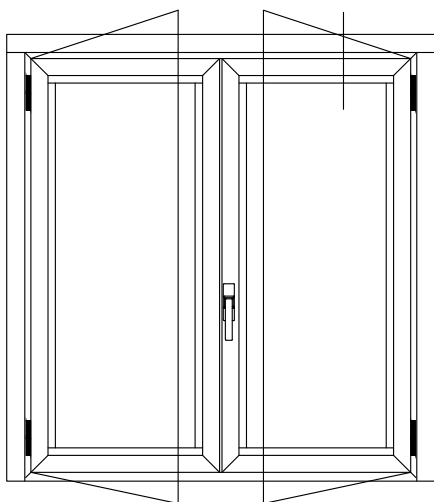

(*) Negli angoli a 45° le squadrette inserite nel tubolare esterno devono essere sempre incollate e cianfrinate. Cianfrinatura eseguibile anche con attrezzatura manuale Cod. M.2001.00
In the 45° corners, the corner joints in the external tubular section, must always be glued and caulked. Caulking may also be carried out by hand with equipment Art.M.2001.00

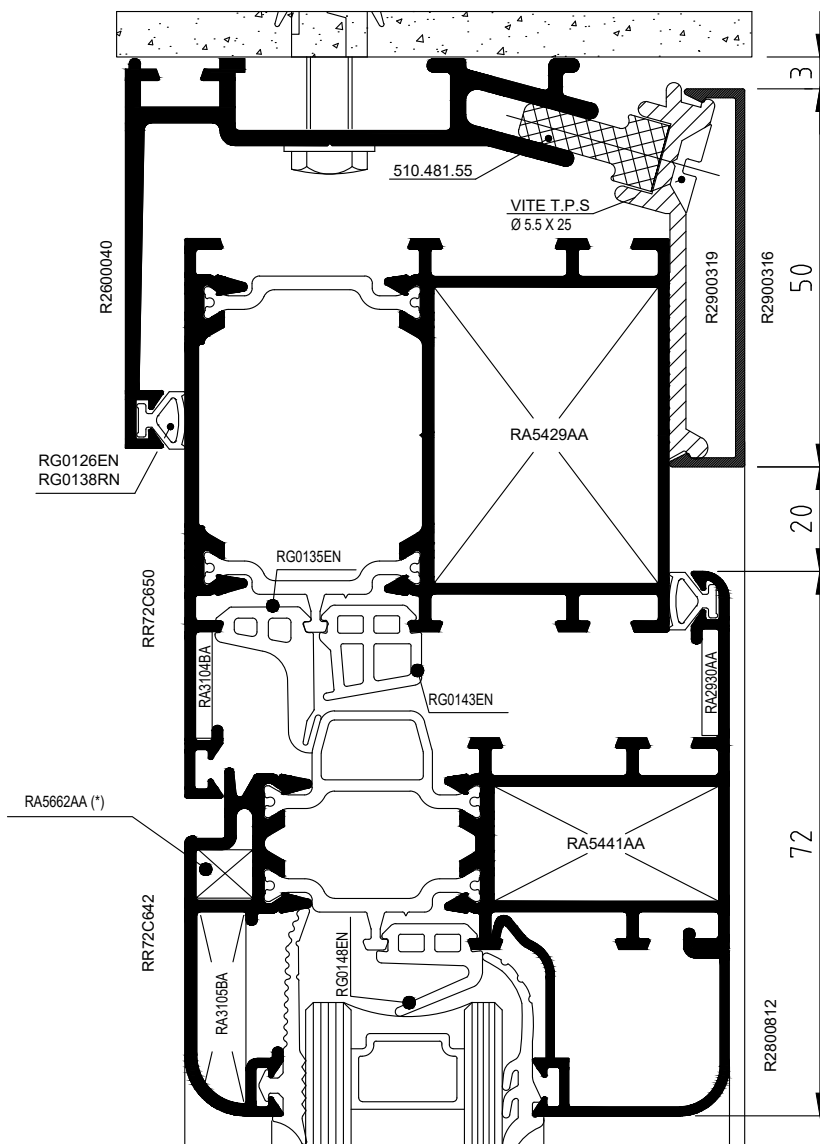

FISSAGGI ALLA MURATURA CON COMPENSATORI
FIXING TO WALL WITH COMPENSATORS

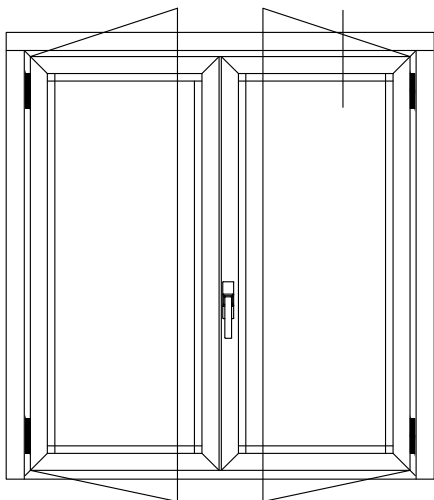

(*) Negli angoli a 45° le squadrette inserite nel tubolare esterno devono essere sempre incollate e cianfrinate. Cianfrinatura eseguibile anche con attrezzatura manuale Cod. M.2001.OO
In the 45° corners, the corner joints in the external tubular section, must always be glued and caulked. Caulking may also be carried out by hand with equipment Art.M.2001.OO

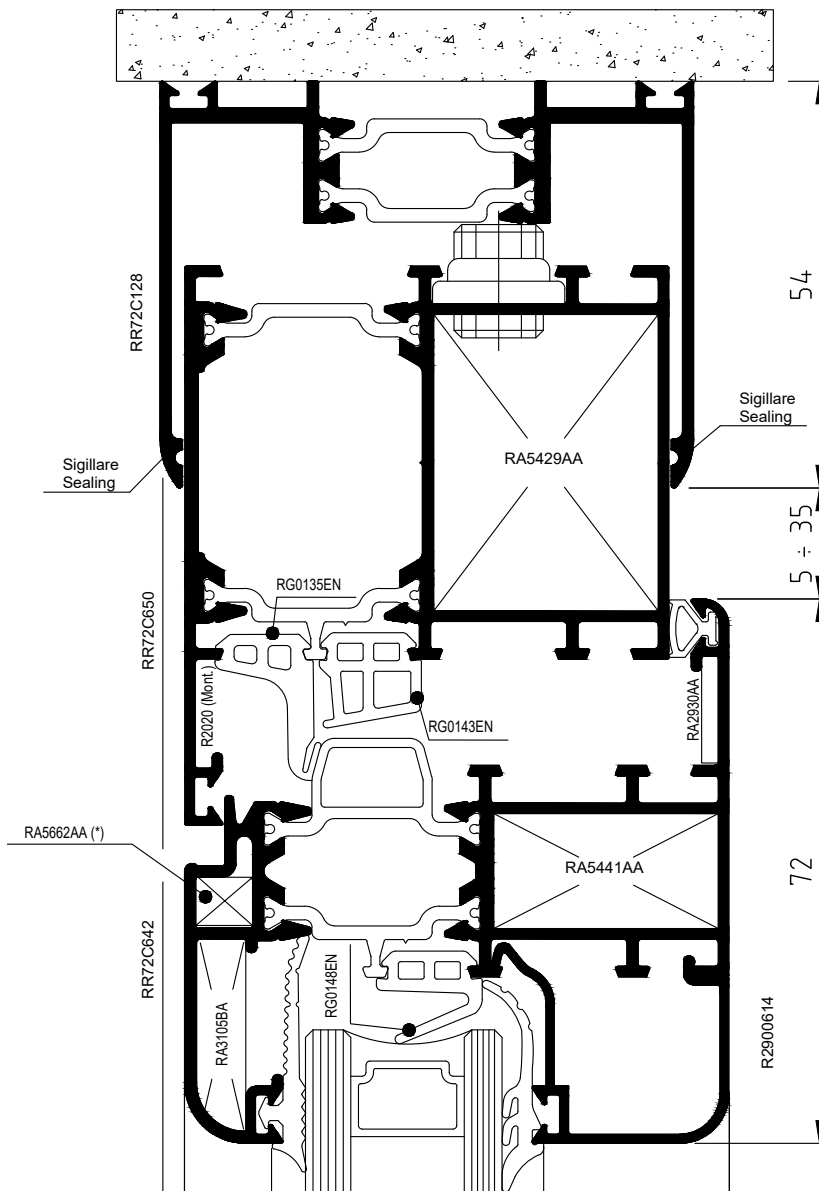

FISSAGGI ALLA MURATURA CON COMPENSATORI
FIXING TO WALL WITH COMPENSATORS

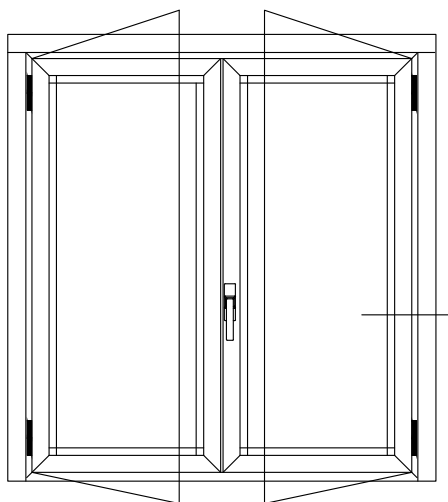

(*) Negli angoli a 45° le squadrette inserite nel tubolare esterno devono essere sempre incollate e cianfrinate. Cianfrinatura eseguibile anche con attrezzatura manuale Cod. M.2001.OO
In the 45° corners, the corner joints in the external tubular section, must always be glued and caulked. Caulking may also be carried out by hand with equipment Art.M.2001.OO

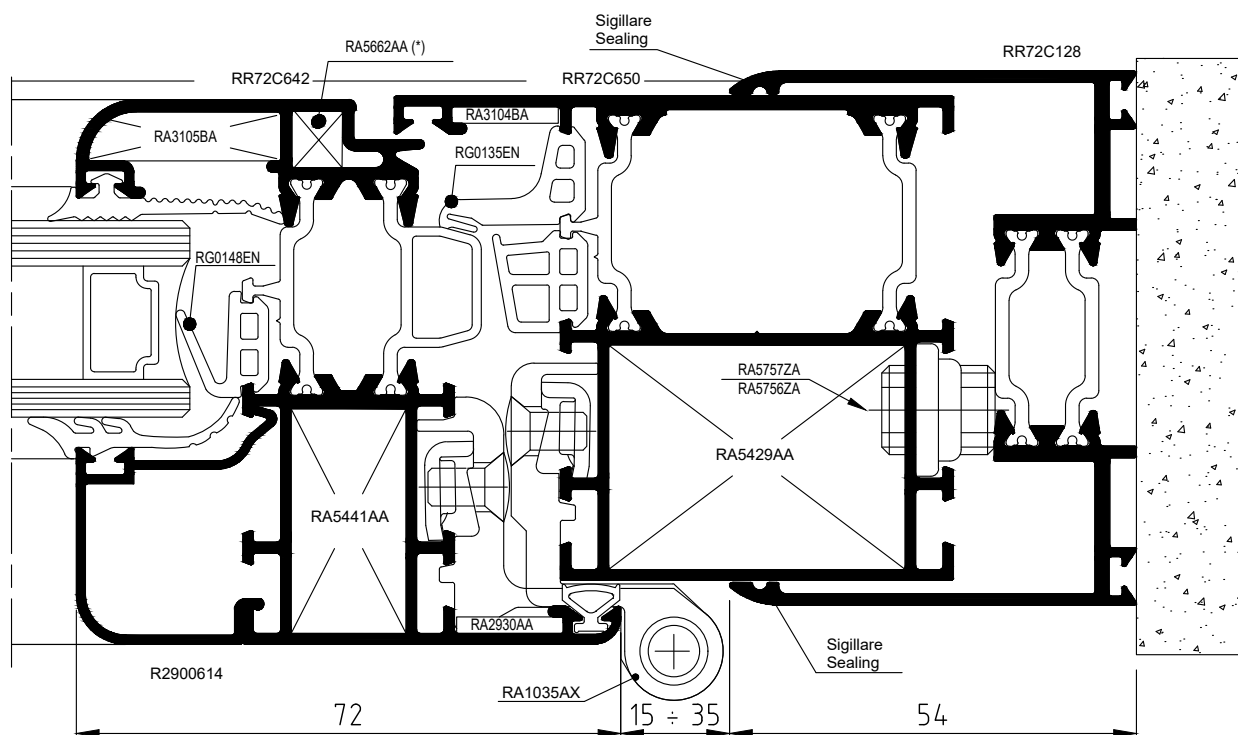

TELAIO PER ABBINAMENTO CON FACCIATA W50
FRAME TO COMBINED WITH CURTAIN WALL W50

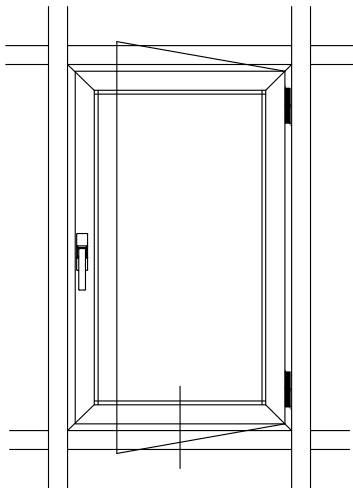

(*) Negli angoli a 45° le squadrette inserite nel tubolare esterno devono essere sempre incollate e cianfrinate. Cianfrinatura eseguibile anche con attrezzatura manuale Cod. M.2001.OO
In the 45° corners, the corner joints in the external tubular section, must always be glued and caulked. Caulking may also be carried out by hand with equipment Art.M.2001.OO

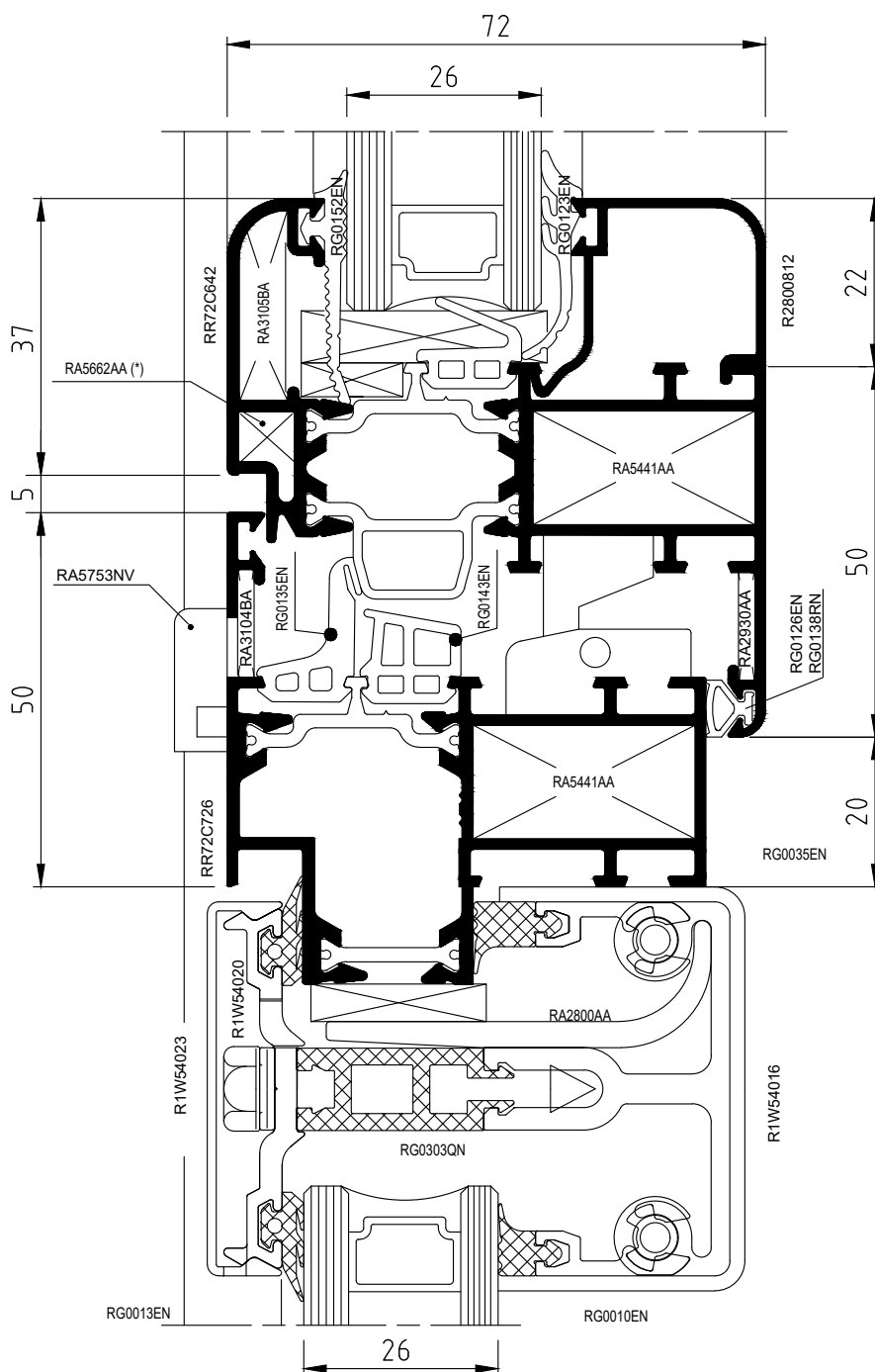

TELAIO ABBINAMENTO W50 CON PORTE APERTURA ESTERNA
FRAME TO COMBINED W50 WITH OUTWARD OPENING DOOR

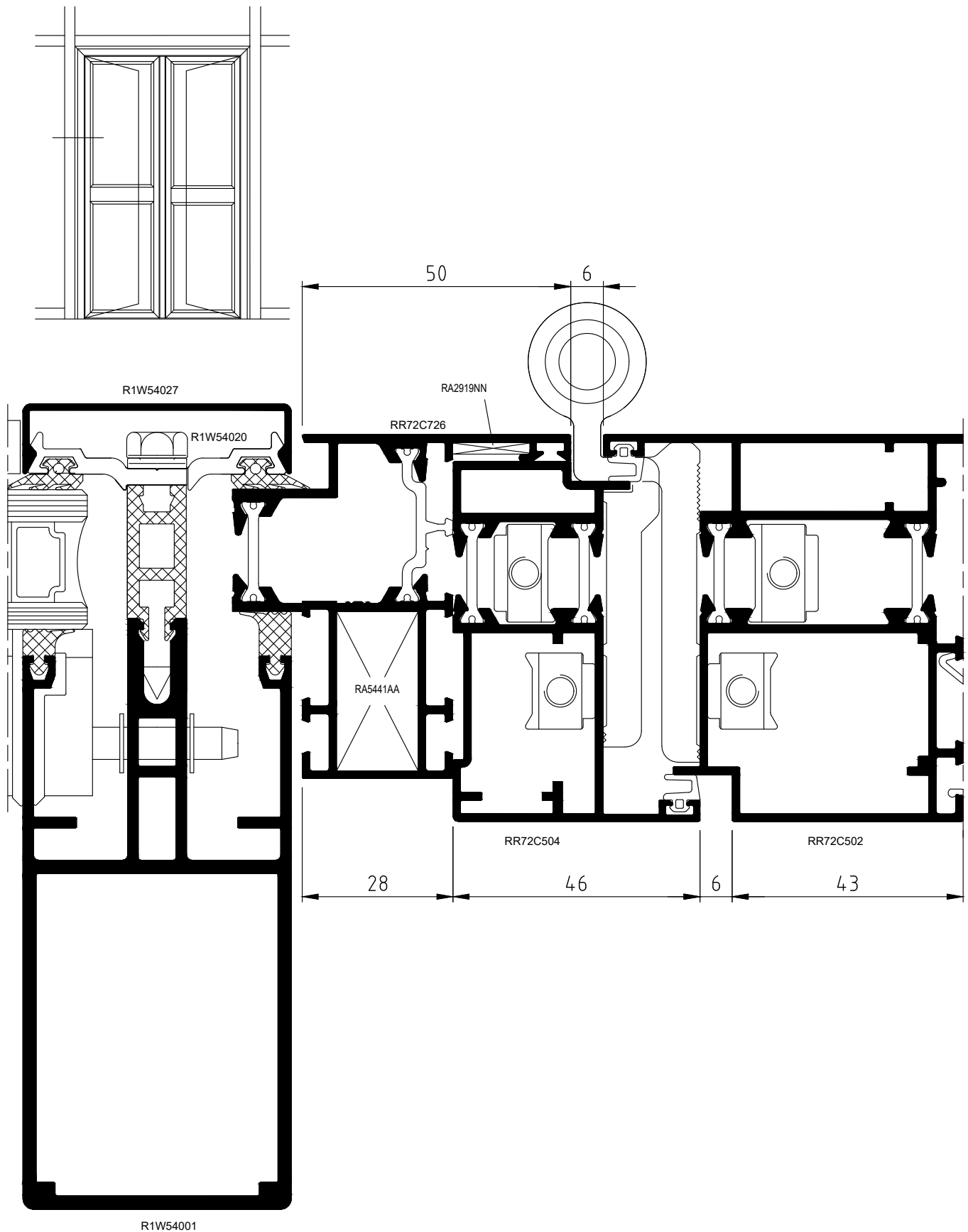

PORTA DUE ANTE + FISSO APERTURA ESTERNA CON PROF. RR72C704
TWO WINGS + FIX DOOR OUTWARD OPENING WITH RR72C704

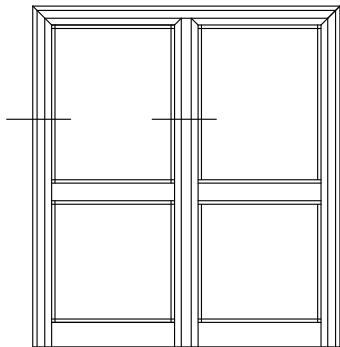

✕ **Asportare dentini per l'altezza del tappo RA2127TN**
Removed pins for the total height on the plug RA2127TN

Attenzione: L' RR72C704 non è utilizzabile con innesti guida e cremone per apertura esterna
Attention: RR72C704 is not usable with cremone bolt and couplings for external opening

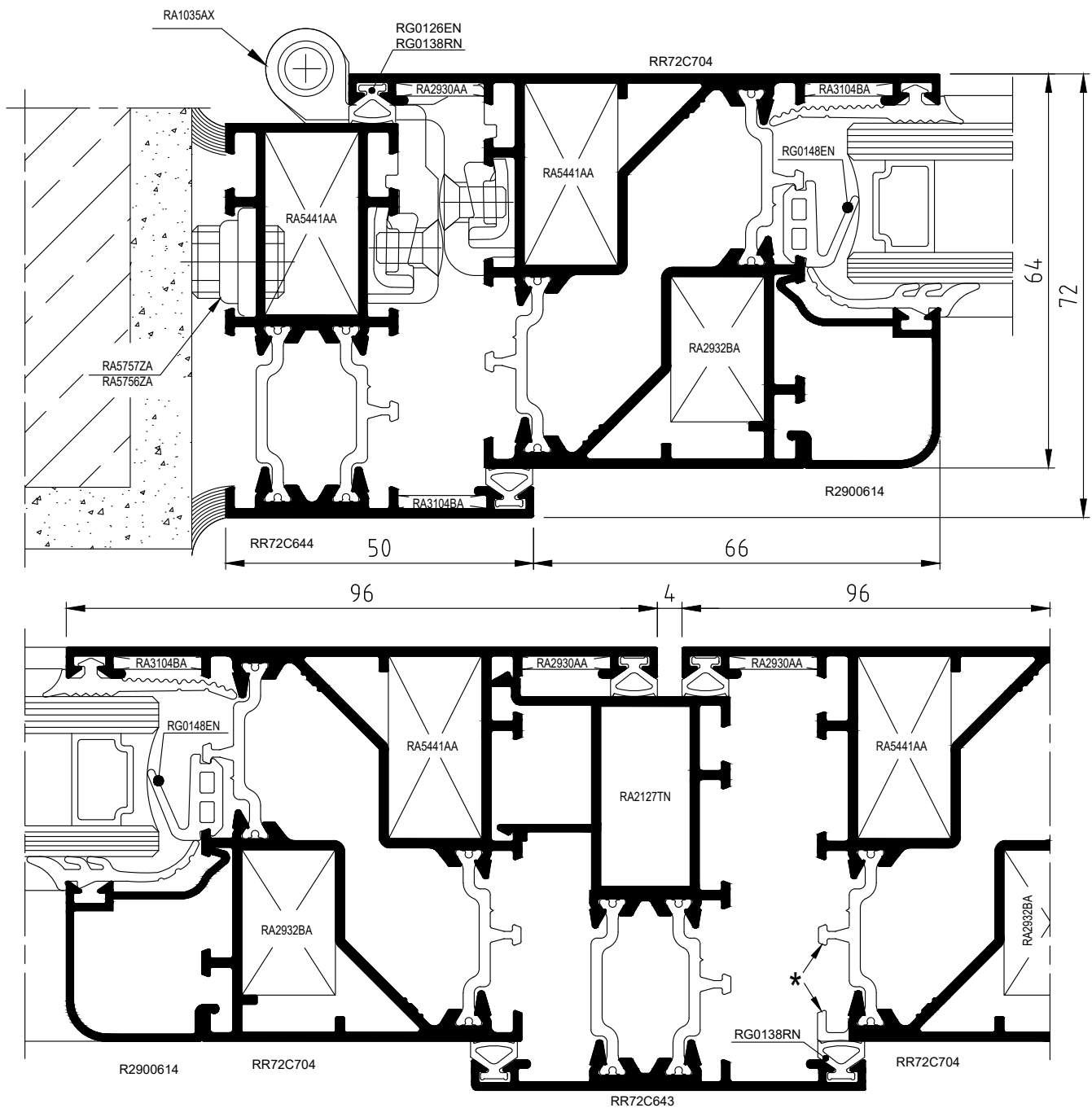

MONTANTE D'ANGOLO A 90°
CORNER MULLION 90°

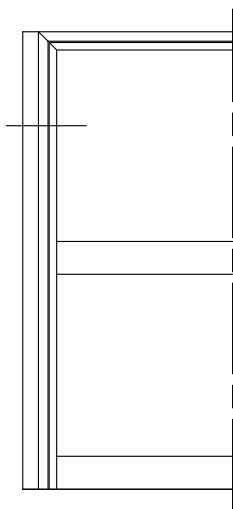

(*) Negli angoli a 45° le squadrette inserite nel tubolare esterno devono essere sempre incollate e cianfrinate.
Cianfrinatura eseguibile anche con attrezzatura manuale Cod. M.2001.OO
In the 45° corners, the corner joints in the external tubular section, must always be glued and caulked. Caulking may also be carried out by hand with equipment Art.M.2001.OO

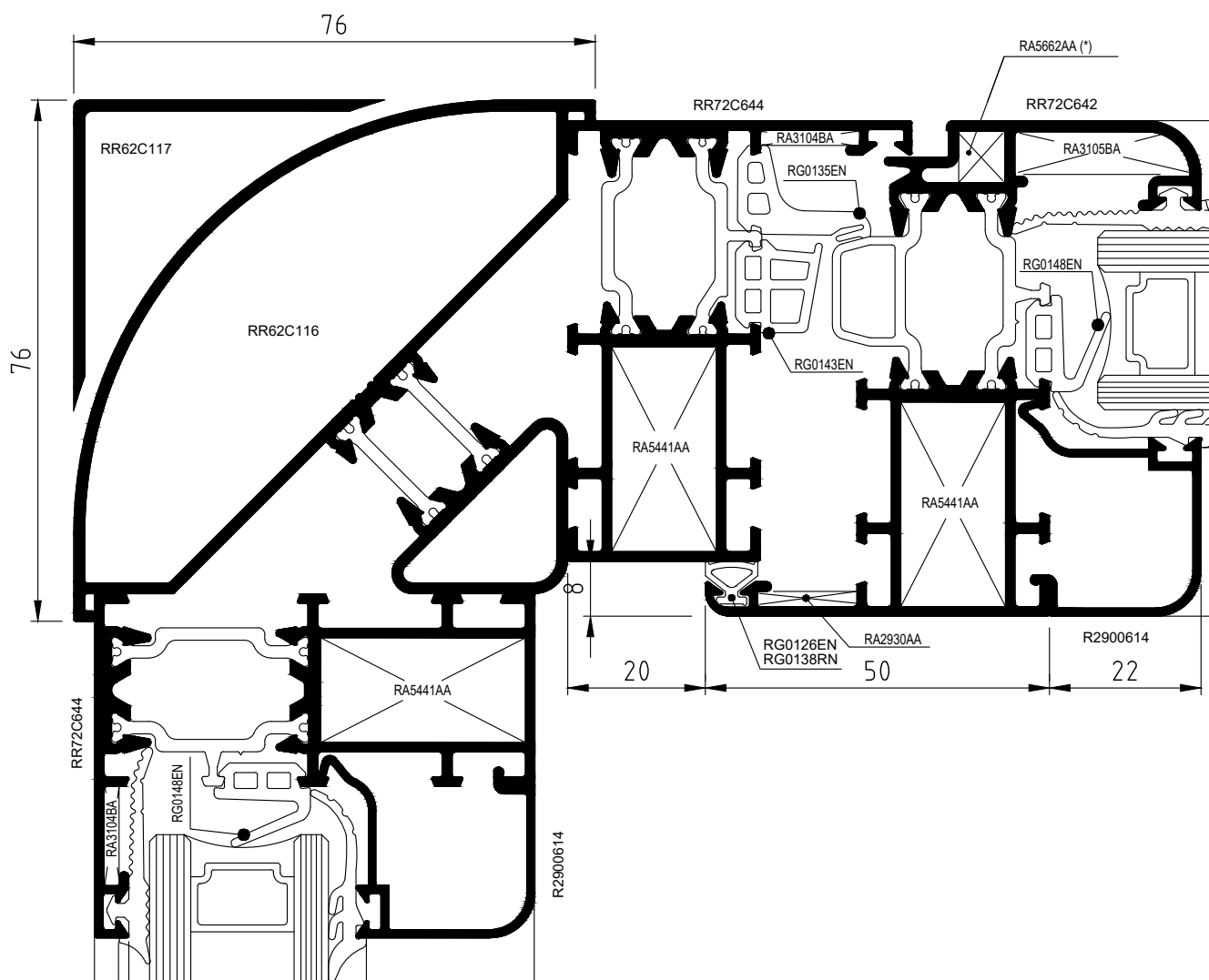

FINESTRA A DUE ANTE "FERRAMENTA PERIMETRALE"
TWO WINGS WINDOW "PERIMETRAL FITTING"

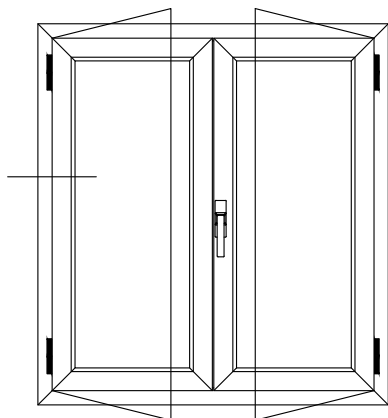

(*) Negli angoli a 45° le squadrette inserite nel tubolare esterno devono essere sempre incollate e cianfrinate. Cianfrinatura eseguibile anche con attrezzatura manuale Cod. M.2001.OO
In the 45° corners, the corner joints in the external tubular section, must always be glued and caulked. Caulking may also be carried out by hand with equipment Art.M.2001.OO

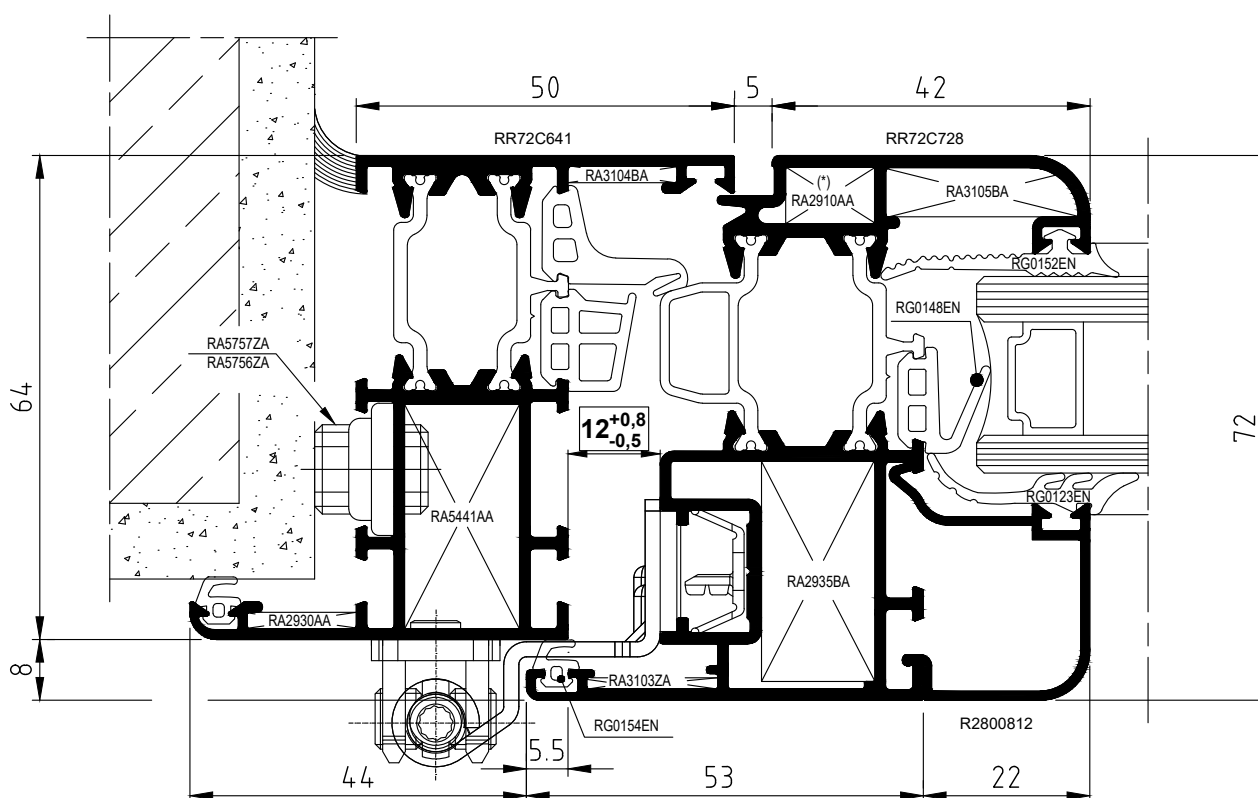

FINESTRA A DUE ANTE "FERRAMENTA PERIMETRALE"
TWO WINGS WINDOW "PERIMETRAL FITTING"

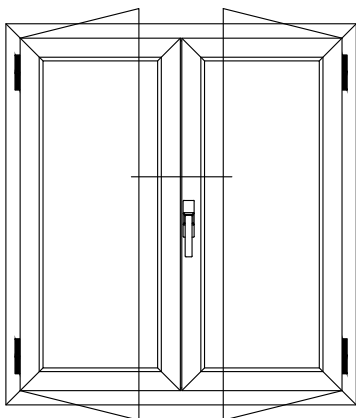

(*) Negli angoli a 45° le squadrette inserite nel tubolare esterno devono essere sempre incollate e cianfrinate. Cianfrinatura eseguibile anche con attrezzatura manuale Cod. M.2001.OO
In the 45° corners, the corner joints in the external tubular section, must always be glued and caulked. Caulking may also be carried out by hand with equipment Art.M.2001.OO

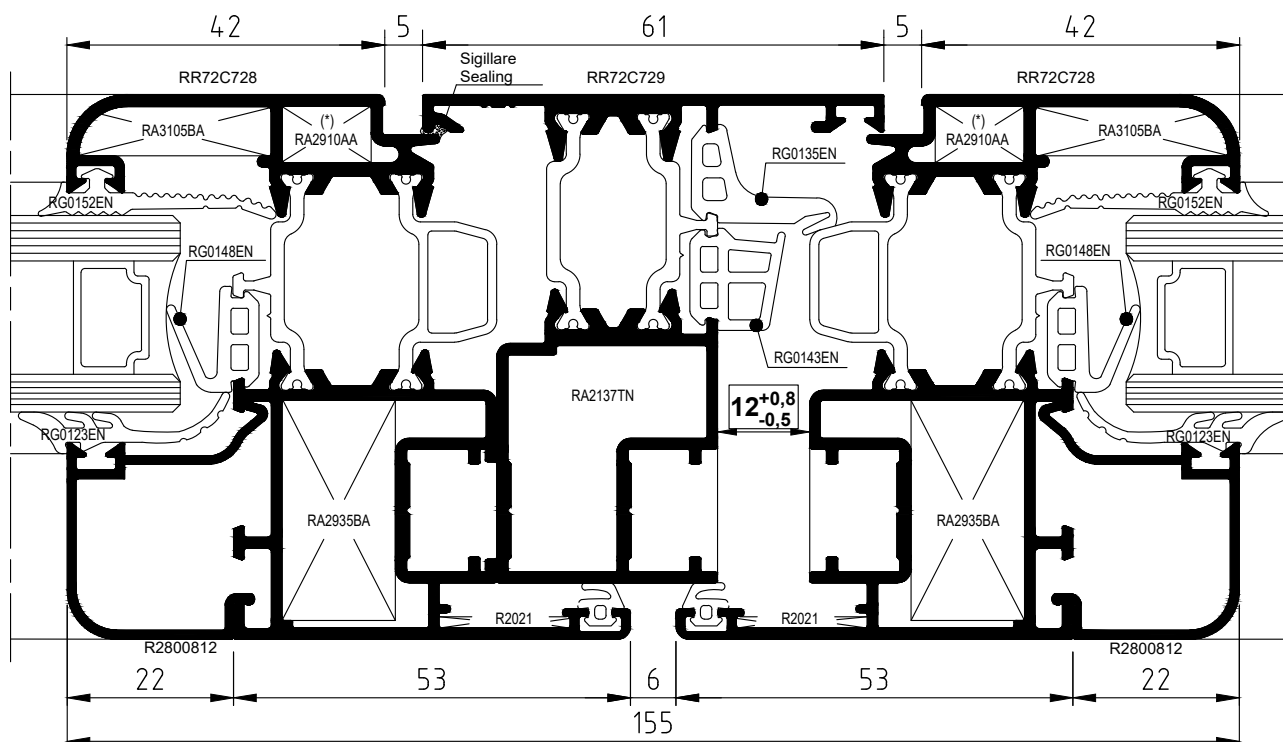

FINESTRA A DUE ANTE "FERRAMENTA PERIMETRALE"
TWO WINGS WINDOW "PERIMETRAL FITTING"

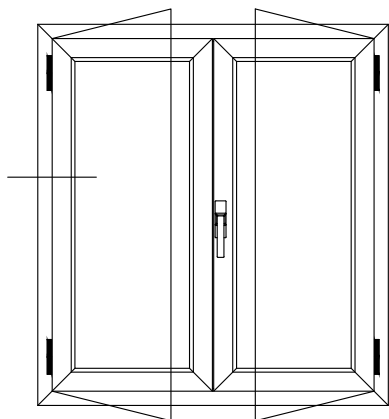

(*) Negli angoli a 45° le squadrette inserite nel tubolare esterno devono essere sempre incollate e cianfrinate. Cianfrinatura eseguibile anche con attrezzatura manuale Cod. M.2001.OO
In the 45° corners, the corner joints in the external tubular section, must always be glued and caulked. Caulking may also be carried out by hand with equipment Art.M.2001.OO

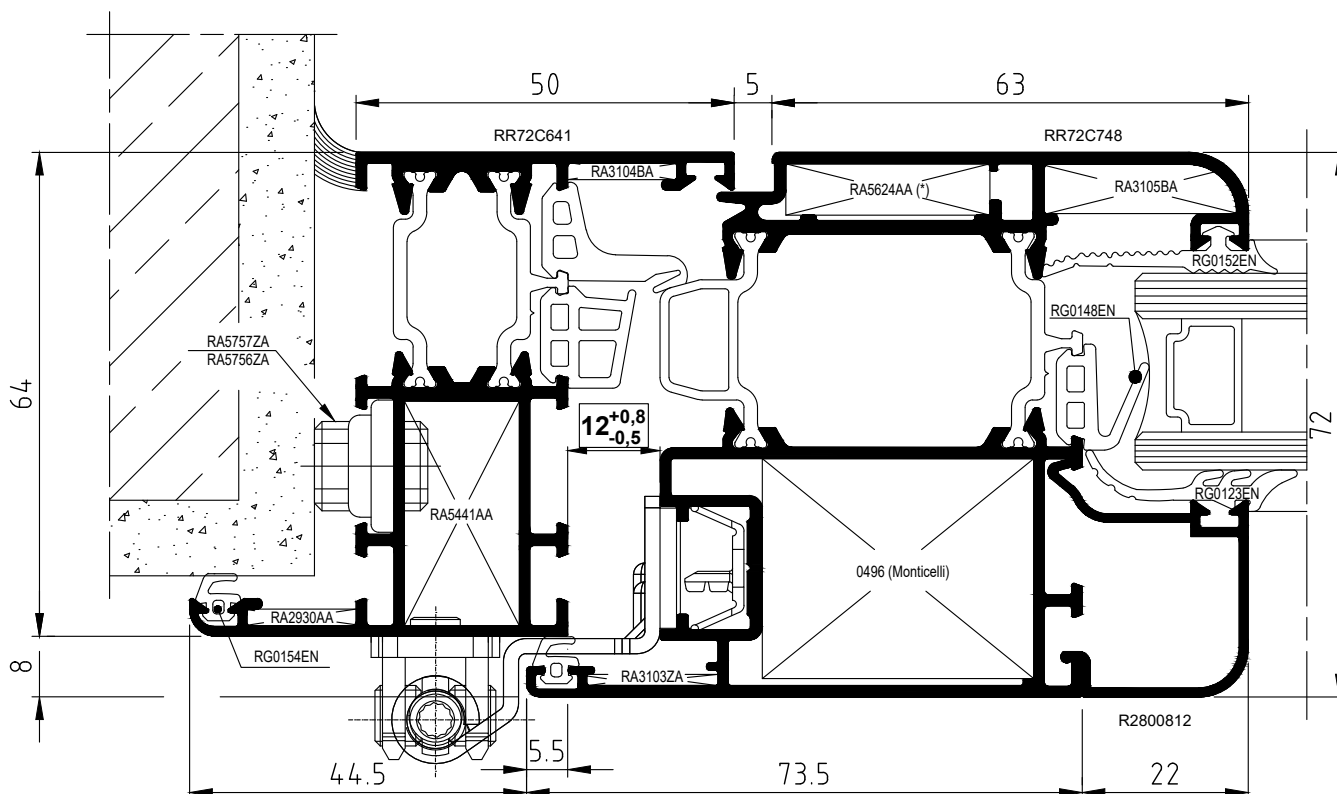

FINESTRA A DUE ANTE "FERRAMENTA PERIMETRALE"
TWO WINGS WINDOW "PERIMETRAL FITTING"

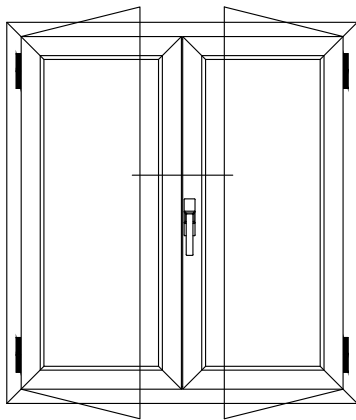

(*) Negli angoli a 45° le squadrette inserite nel tubolare esterno devono essere sempre incollate e cianfrinate. Cianfrinatura eseguibile anche con attrezzatura manuale Cod. M.2001.OO
In the 45° corners, the corner joints in the external tubular section, must always be glued and caulked. Caulking may also be carried out by hand with equipment Art.M.2001.OO

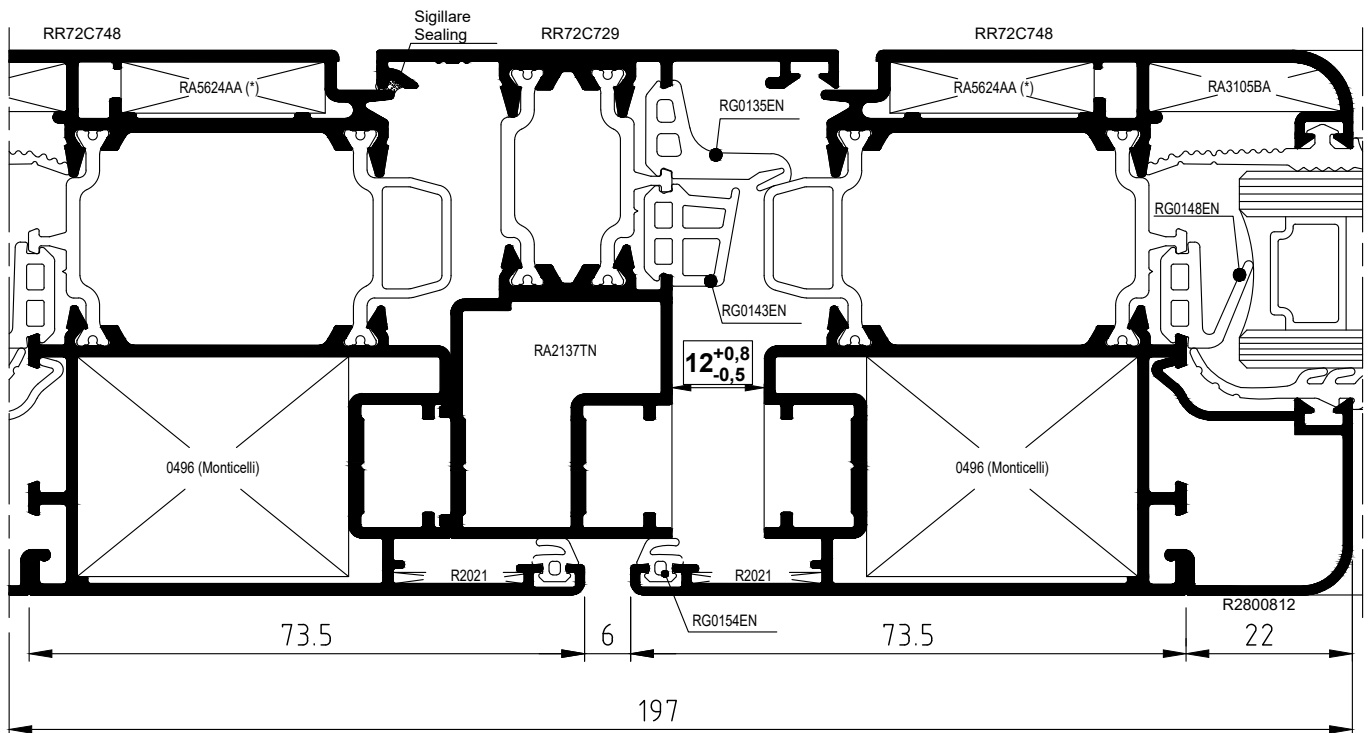

BILICO ORIZZONTALE E VERTICALE
HORIZONTAL AND VERTICAL PIVOTING WINDOW

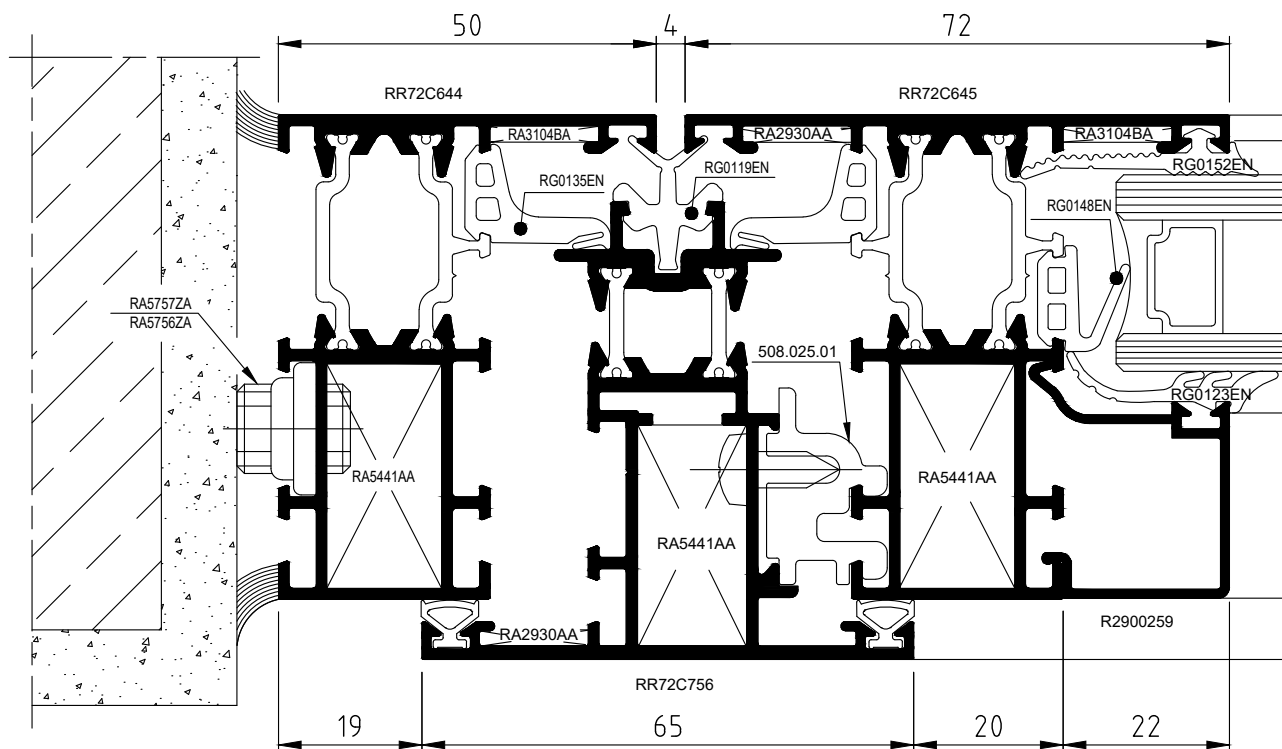
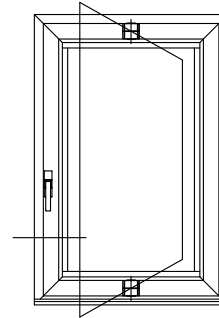
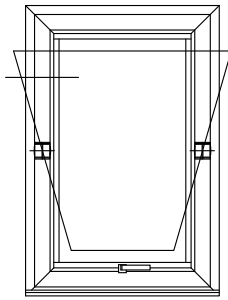

SEZIONI - LAVORAZIONE PROFILATO RR72C756
CROSS SECTIONS - TOOLING FOR SECTION RR72C756

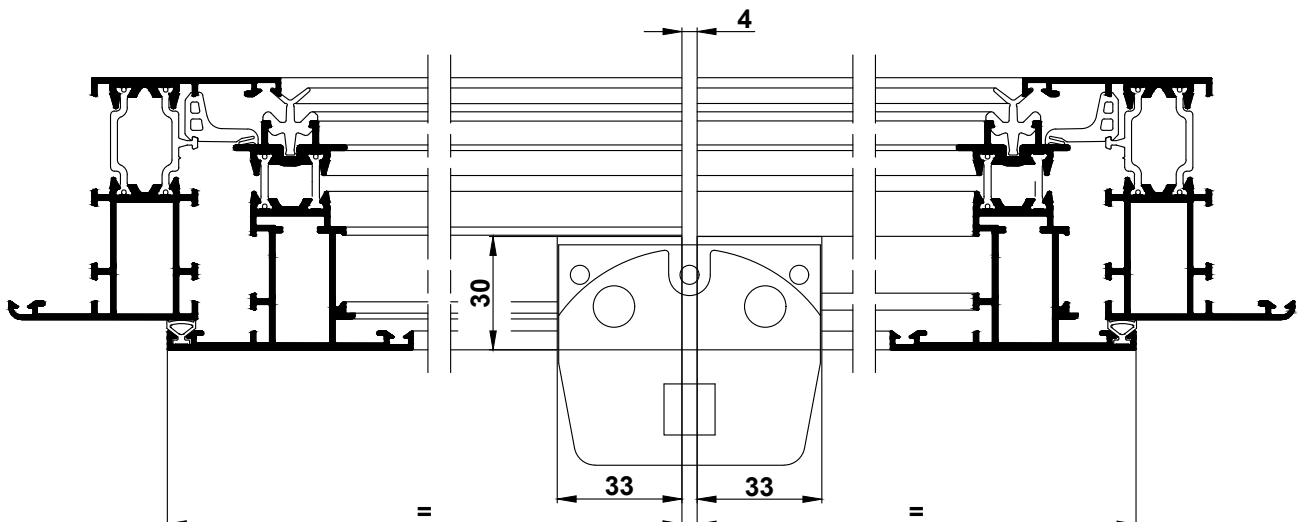

FINESTRA AD UN ANTA RIBALTA
TILT AND TURN WING

Rbalta 150

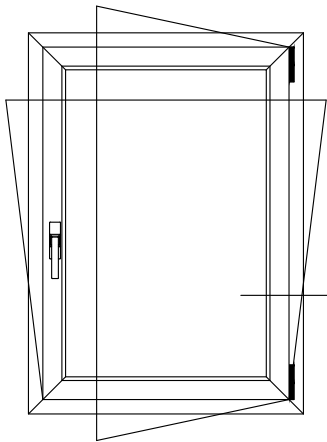

(*) Negli angoli a 45° le squadrette inserite nel tubolare esterno devono essere sempre incollate e cianfrinate. Cianfrinatura eseguibile anche con attrezzatura manuale Cod. M.2001.OO
In the 45° corners, the corner joints in the external tubular section, must always be glued and caulked. Caulking may also be carried out by hand with equipment Art.M.2001.OO

CAMPO DI APPLICAZIONE
APPLICATION RANGE

	2800	50	50	40	30	28	24	22	20	18	16	14	14	13	13	12
	2700	50	50	40	30	28	24	22	20	18	16	14	14	13	13	13
	2600	50	50	40	35	30	26	22	20	18	16	16	14	14	13	13
	2500	50	50	40	35	30	26	24	22	20	18	16	14	14	13	13
	2400	50	50	45	35	30	28	24	22	20	18	16	16	14	14	13
	2300	50	50	45	35	30	28	26	24	22	20	18	16	16	14	14
	2200	50	50	50	40	35	30	26	24	22	20	18	18	16	14	14
	2100	50	50	50	40	35	30	28	26	24	22	20	18	16	16	14
	2000	50	50	50	45	35	30	30	28	24	22	20	18	18	16	16
	1900	50	50	50	45	40	35	30	28	26	24	22	20	18	18	16
	1800	50	50	50	50	40	35	30	30	28	26	22	22	20	18	18
	1700	50	50	50	50	45	40	35	30	30	26	24	22	20	20	18
	1600	50	50	50	50	50	40	35	35	30	28	26	24	22	20	20
	1500	50	50	50	50	50	45	40	35	30	30	28	26	24	22	20
	1400	50	50	50	50	50	45	40	40	35	30	30	28	26	24	•
	1300	50	50	50	50	50	45	40	35	35	30	30	26	•	•	•
	1200	50	50	50	50	50	50	45	40	35	35	30	•	•	•	•
	1100	50	50	50	50	50	50	50	45	40	35	•	•	•	•	•
	1000	50	50	50	50	50	50	50	50	50	40	•	•	•	•	•
	900	50	50	50	50	50	50	50	50	50	50	•	•	•	•	•
	800	50	50	50	50	50	50	50	50	50	50	•	•	•	•	•
	700	50	50	50	50	50	50	50	50	50	50	•	•	•	•	•
	600	50	50	50	50	50	50	50	50	50	50	•	•	•	•	•

H = Altezza anta mobile
H = Height of the moving leaf
L = Larghezza anta mobile
L = Width of the moving leaf

• Non eseguibile
Not feasible

28 Max spessore vetro 28 mm
Max glass thickness 28 mm

N.B. Lo spessore vetro si riferisce al materiale senza camera d'aria
N.B. Glass thickness refers to material without air chamber

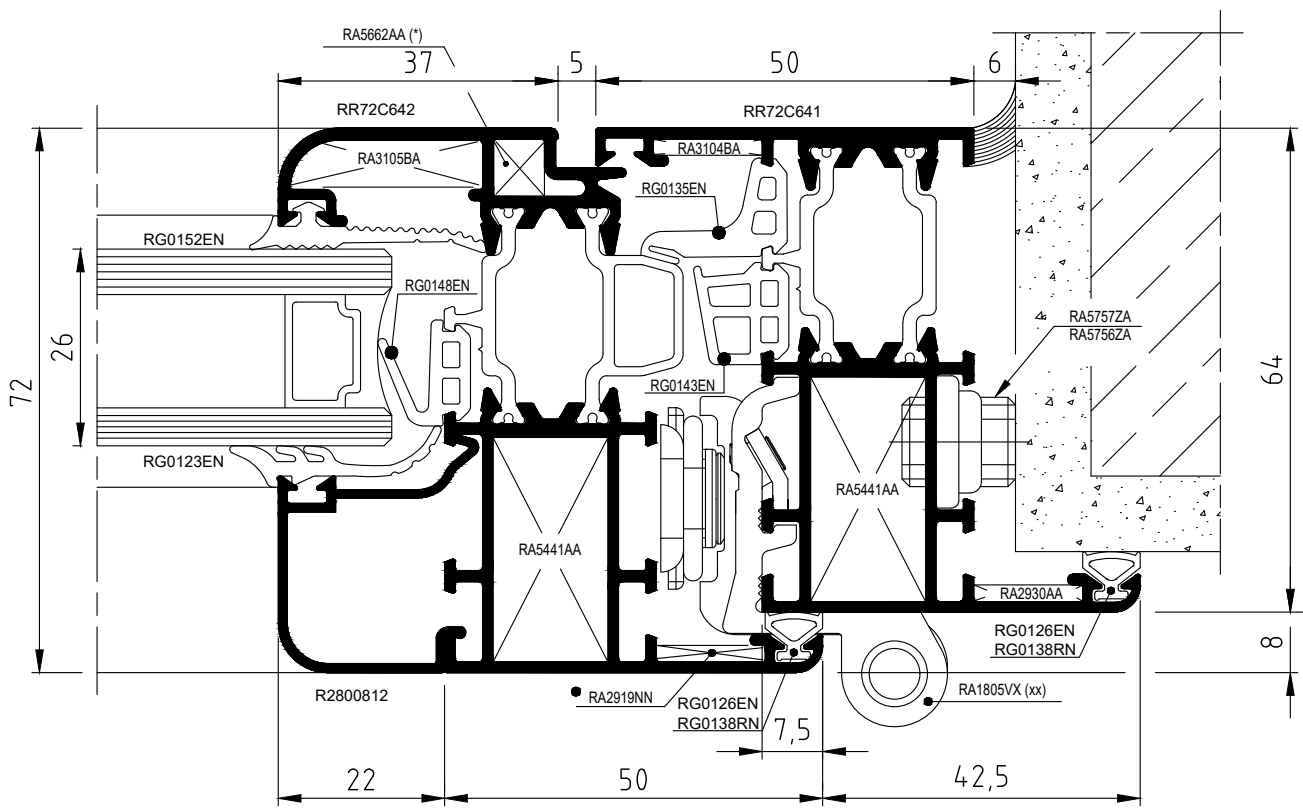

Attenzione: in corrispondenza dei cardini inferiore e superiore utilizzare la squadretta RA2919NN invece della RA2930AA
Attention: in correspondence of the bottom and upper hinges, use corner joint RA2919NN instead of RA2930AA

MONOBLOCCO
MONOBLOCK

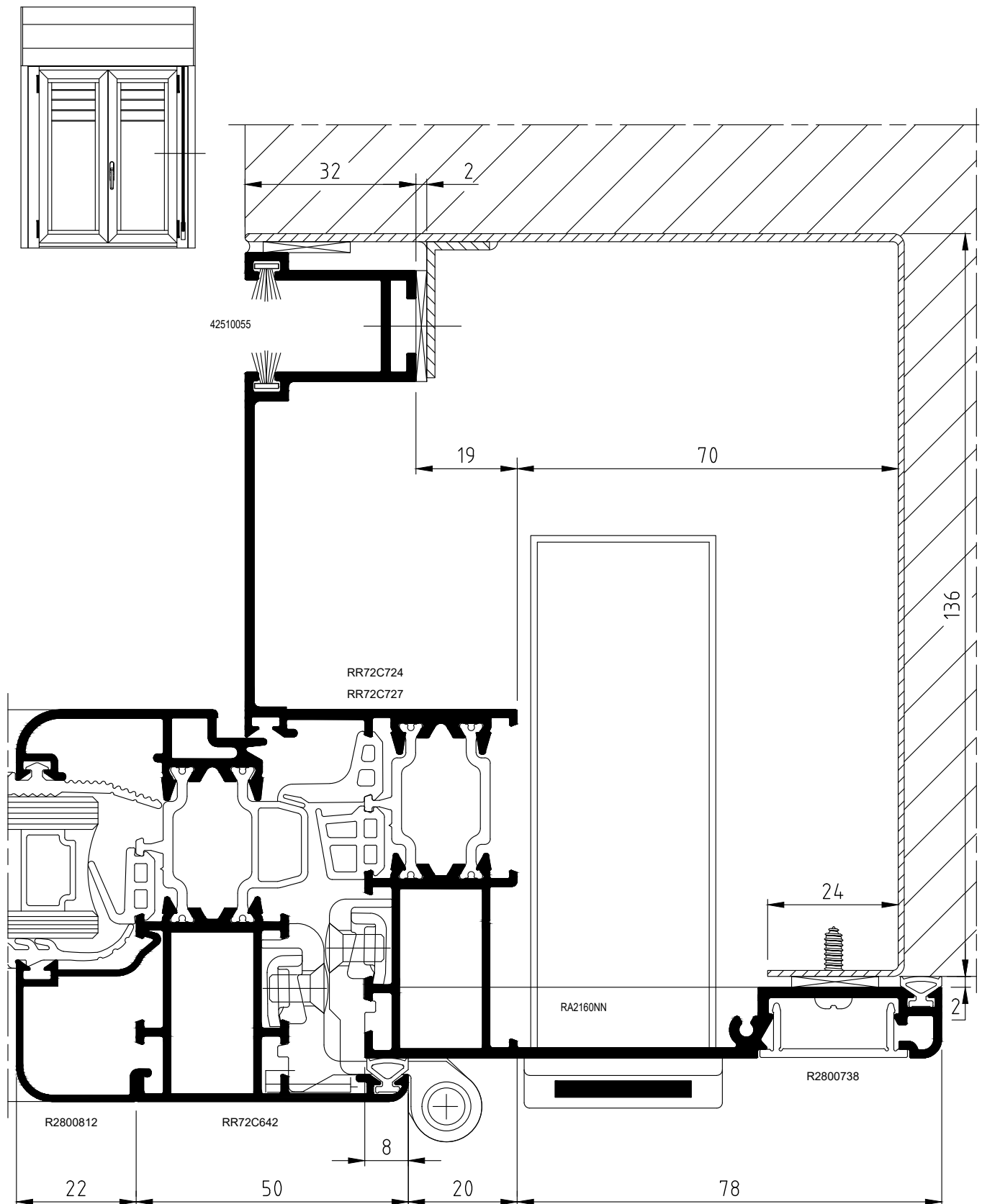

**MONOBLOCCO
MONOBLOCK**

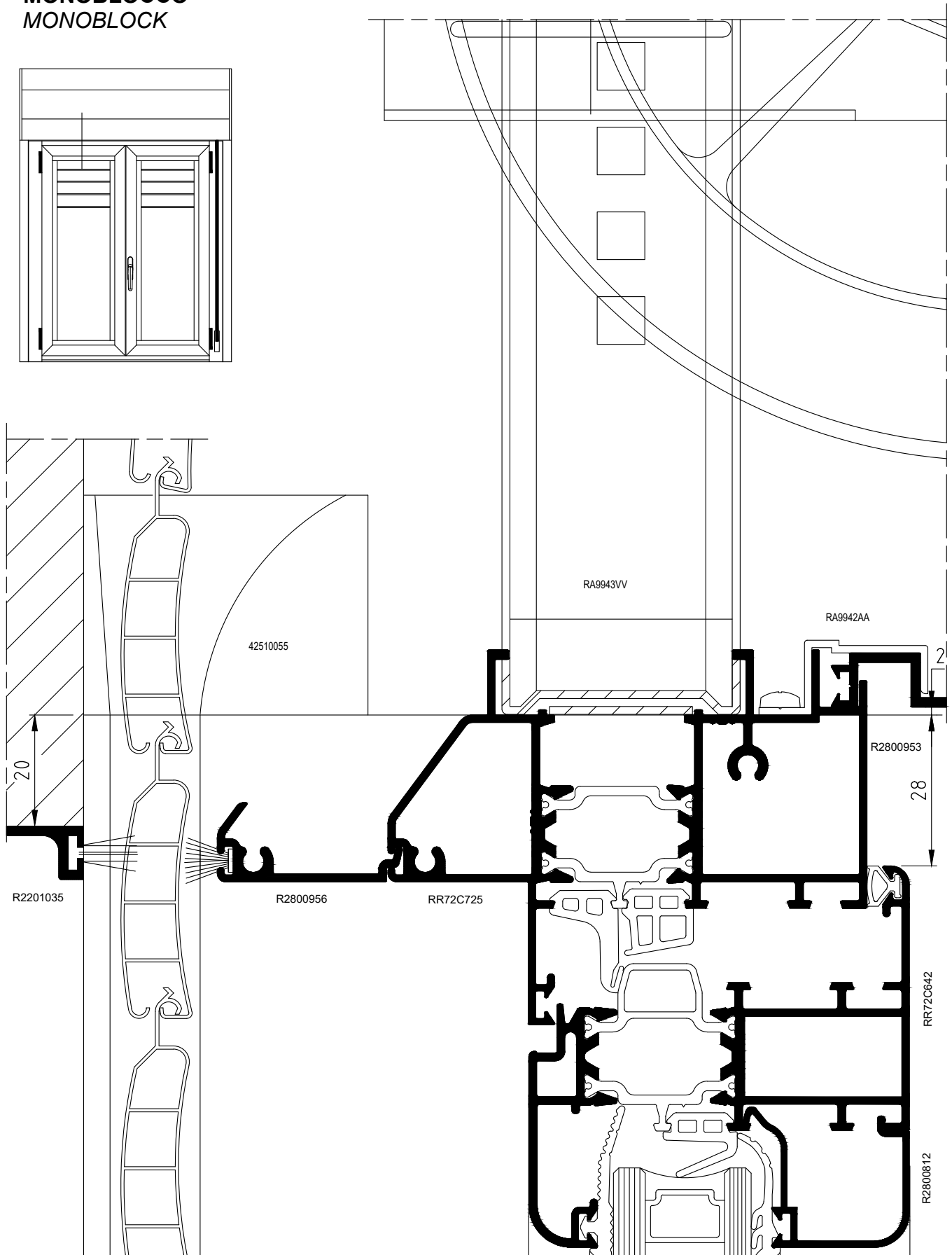
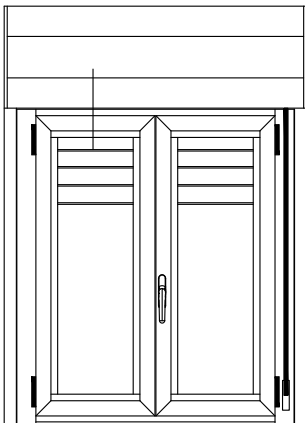

FINESTRA A DUE ANTE CON PROFILATI ESTERNI TUBOLARI
TWO WINGS WINDOW WITH EXTERNAL TUBULAR

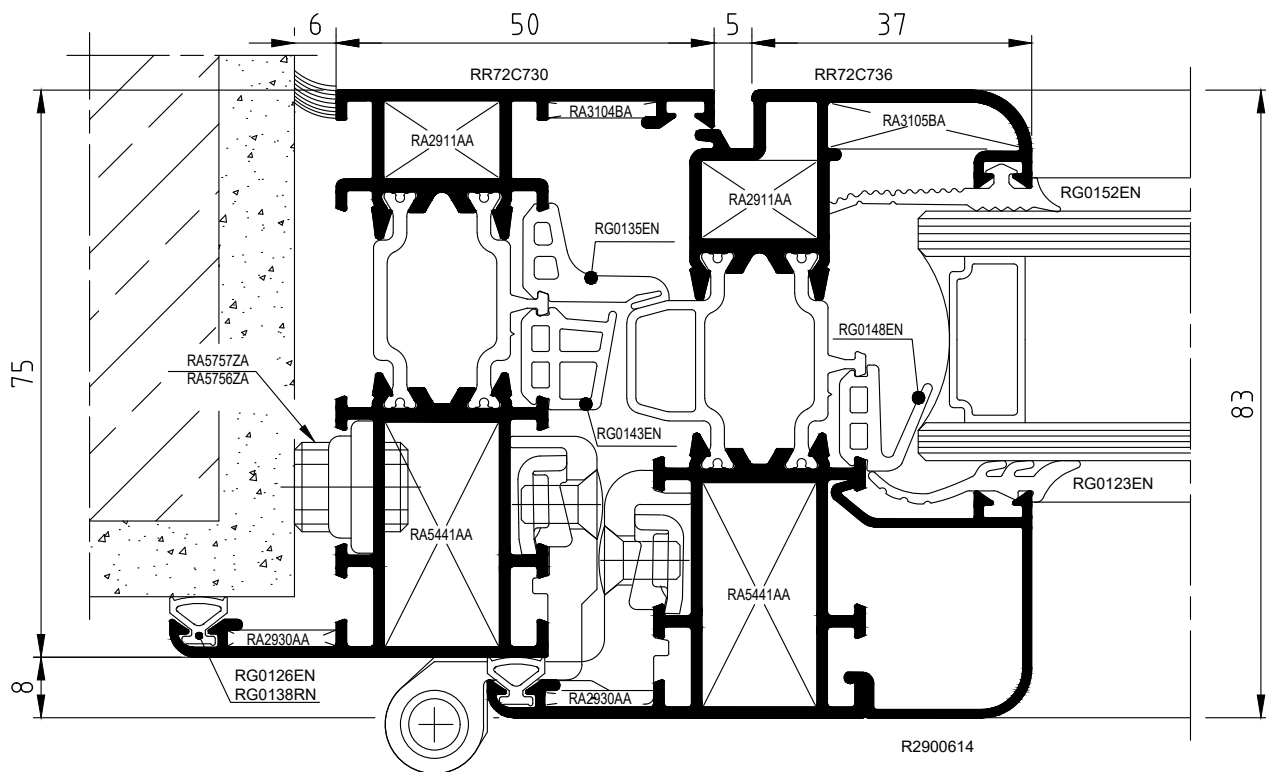
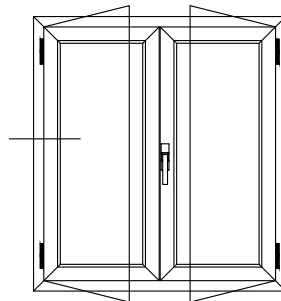

FINESTRA A DUE ANTE CON PROFILATI ESTERNI TUBOLARI
TWO WINGS WINDOW WITH EXTERNAL TUBULAR

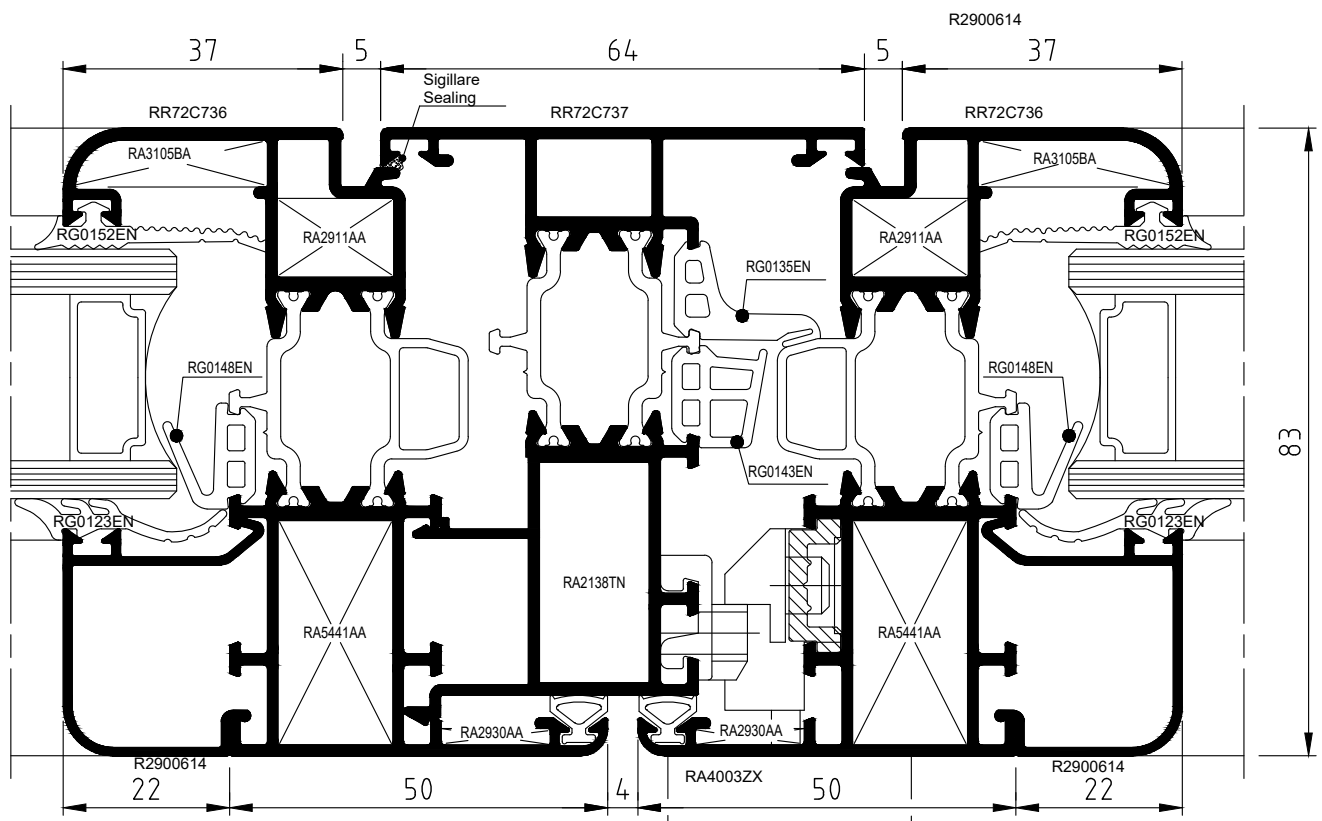
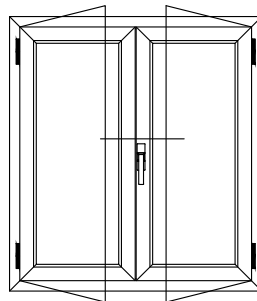

FINESTRA A DUE ANTE CON PROFILATI ESTERNI TUBOLARI
TWO WINGS WINDOW WITH EXTERNAL TUBULAR

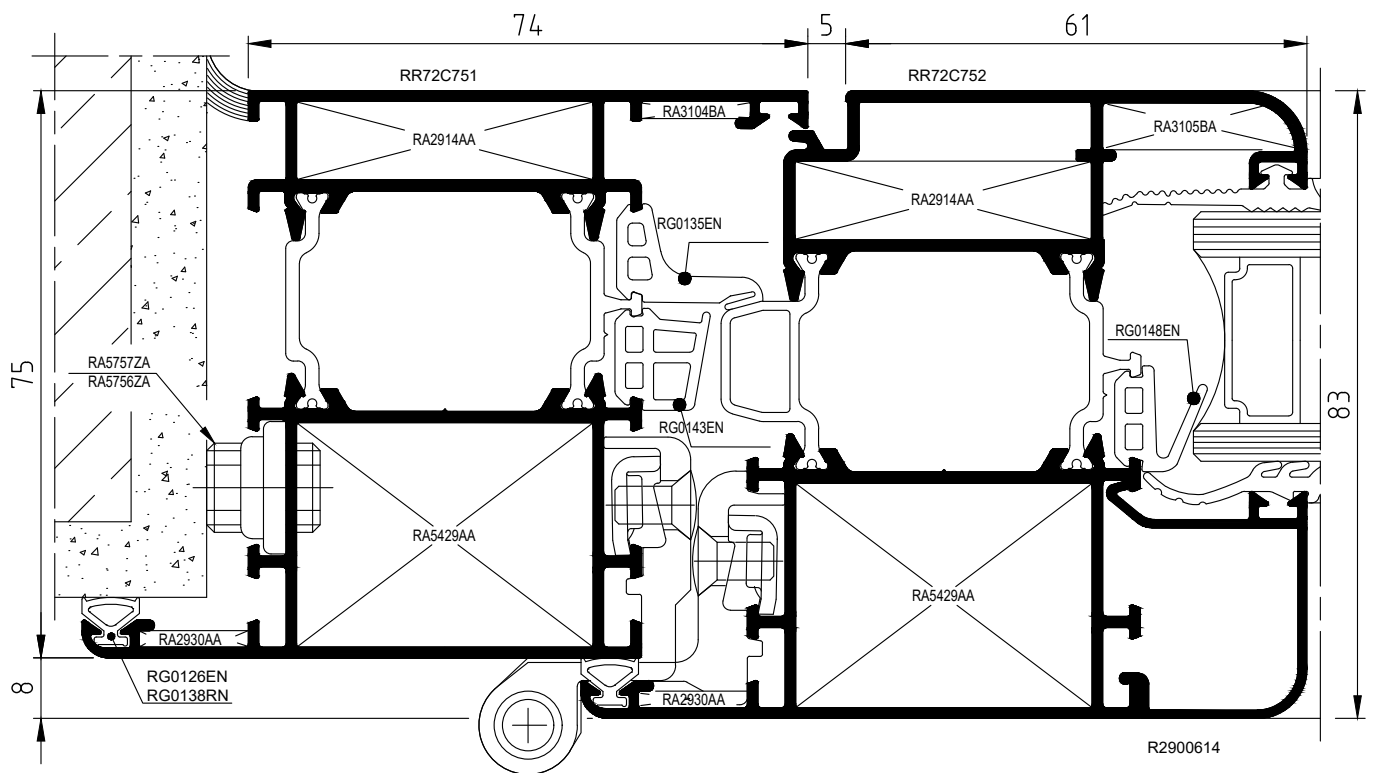
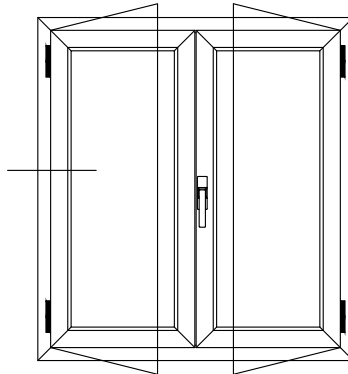

FINESTRA A DUE ANTE CON PROFILATI ESTERNI TUBOLARI
TWO WINGS WINDOW WITH EXTERNAL TUBULAR

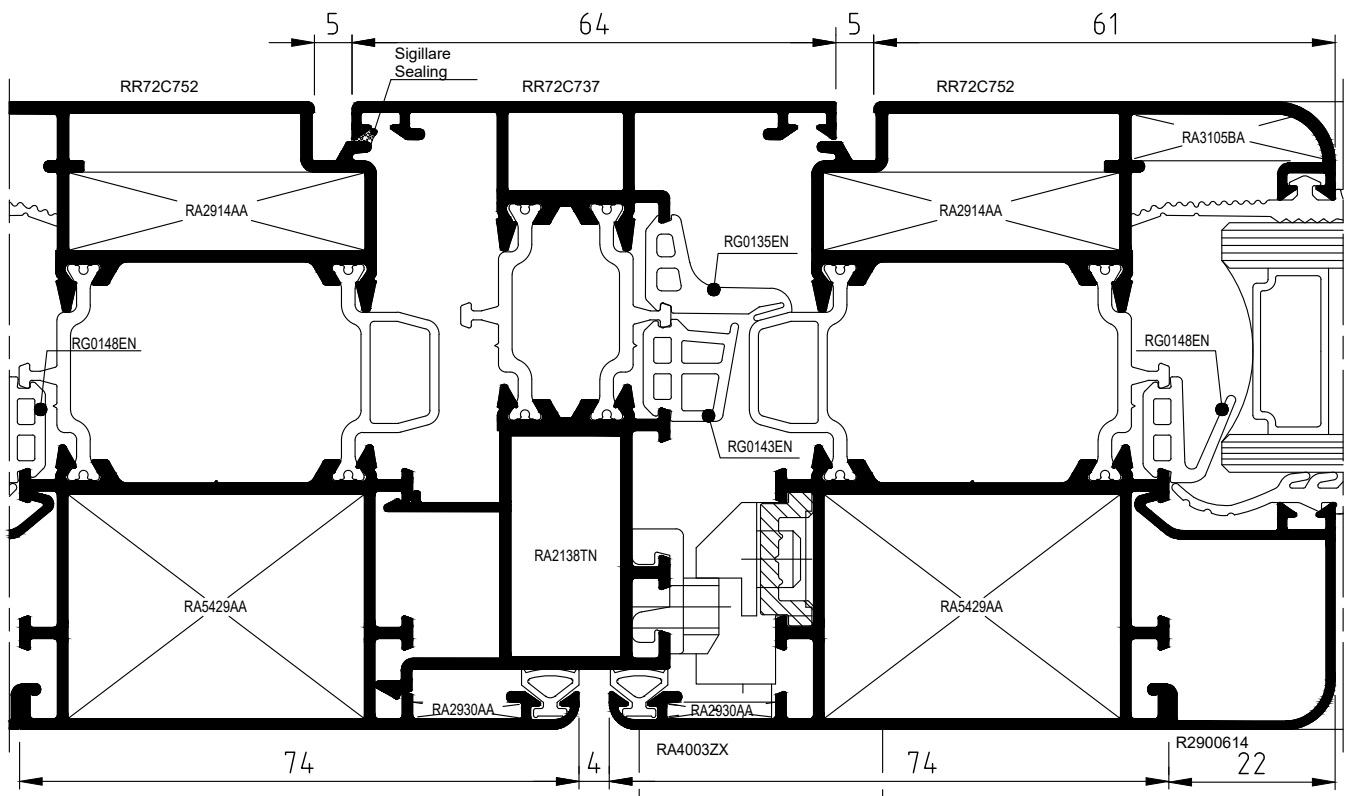
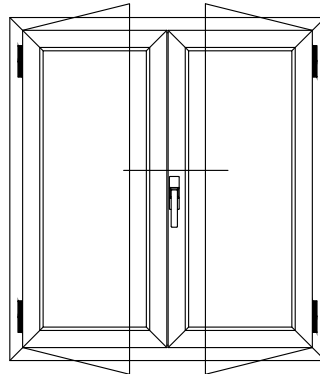

TUBOLARI ESTERNI RIDOTTI
REDUCED EXTERNAL TUBOLARS

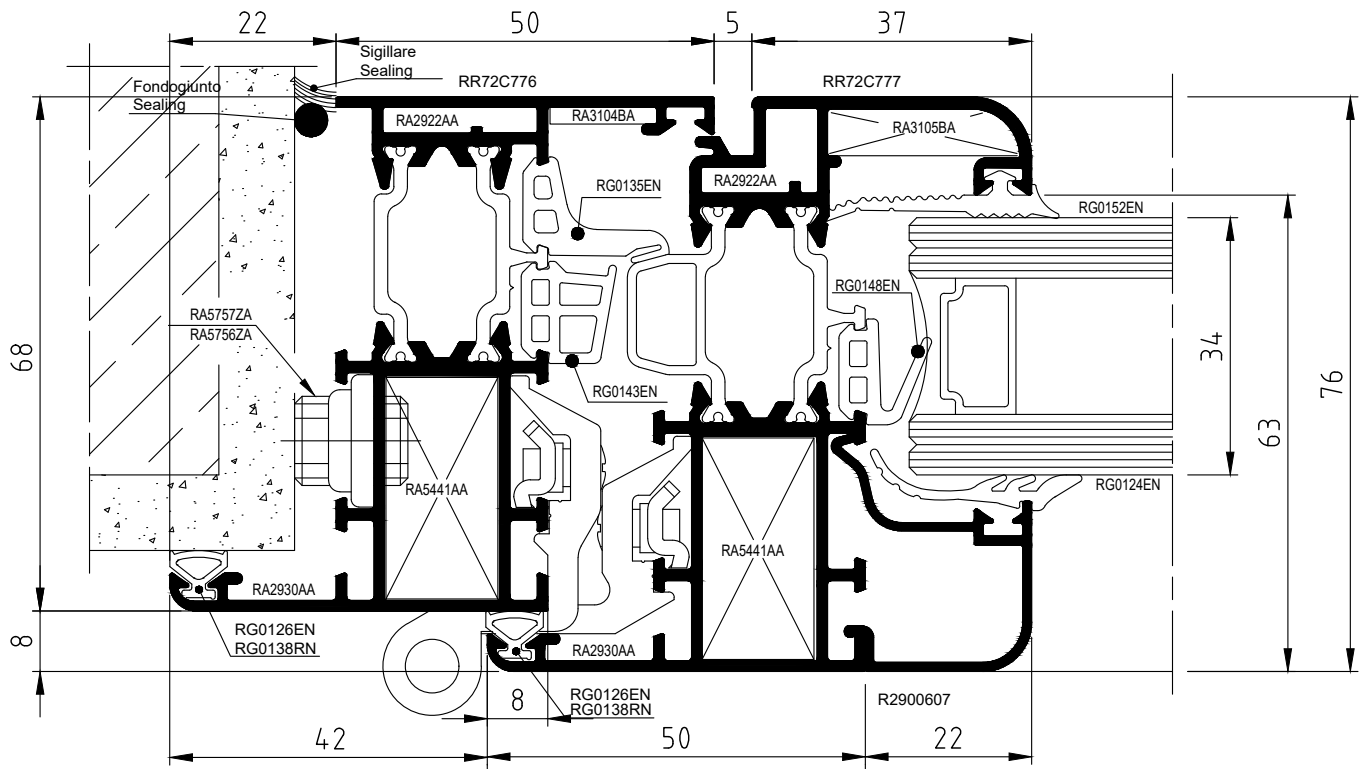
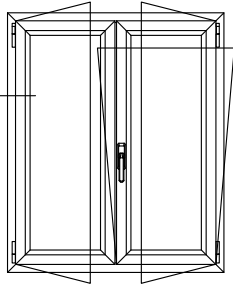

TUBOLARI ESTERNI RIDOTTI
REDUCED EXTERNAL TUBULARS

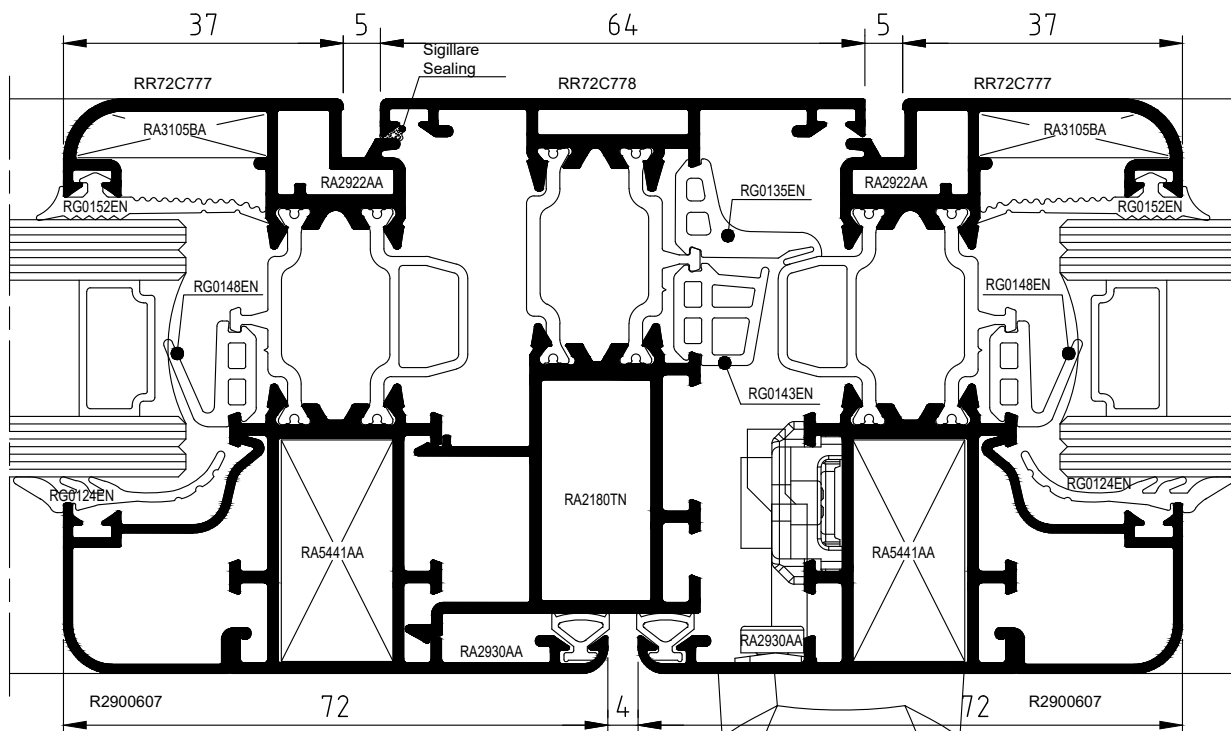
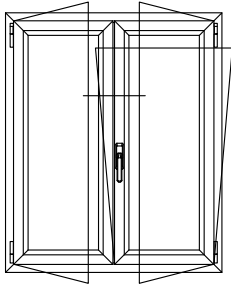

TUBOLARI ESTERNI RIDOTTI
REDUCED EXTERNAL TUBOLARS

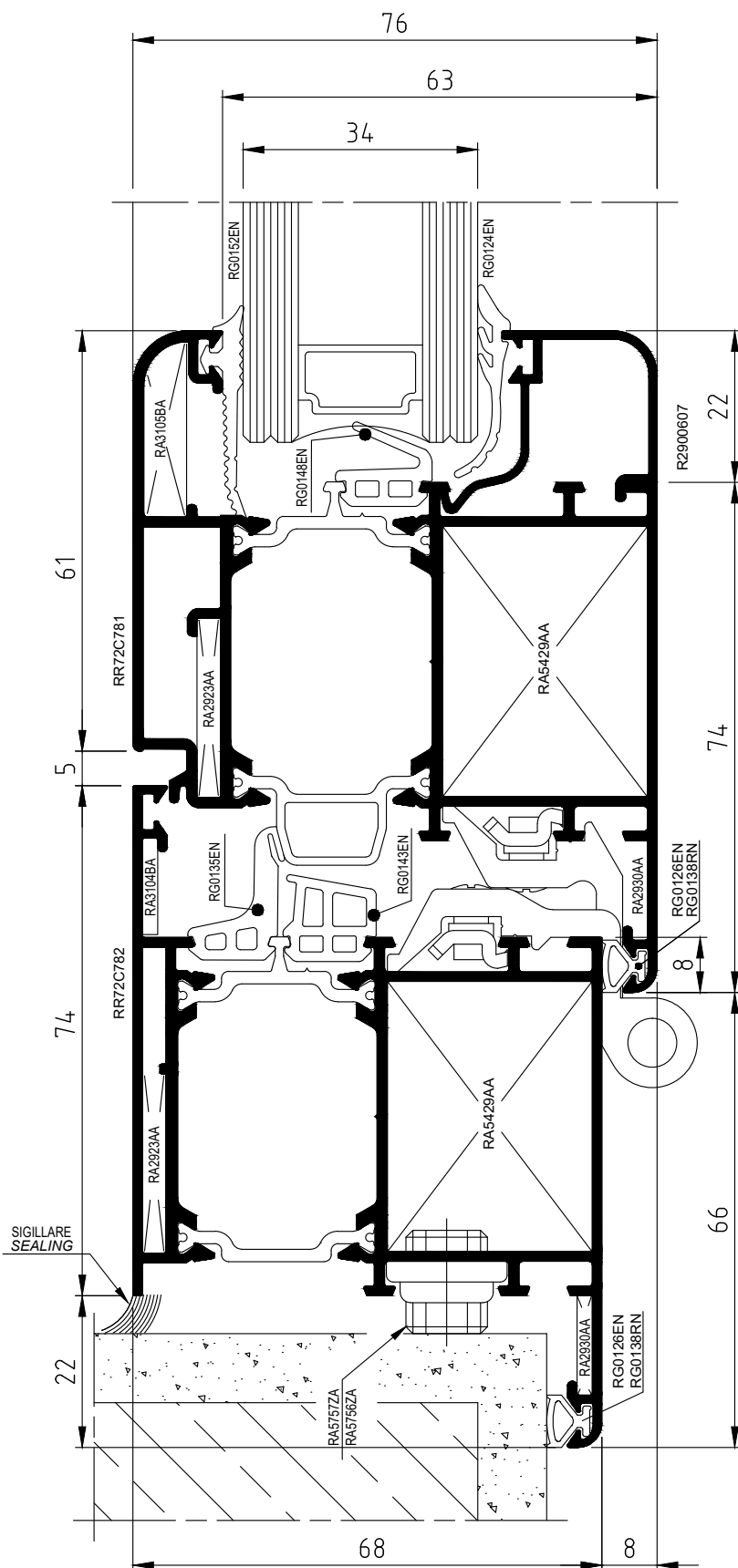
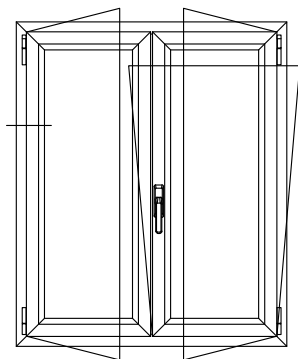

TUBOLARI ESTERNI RIDOTTI
REDUCED EXTERNAL TUBULARS

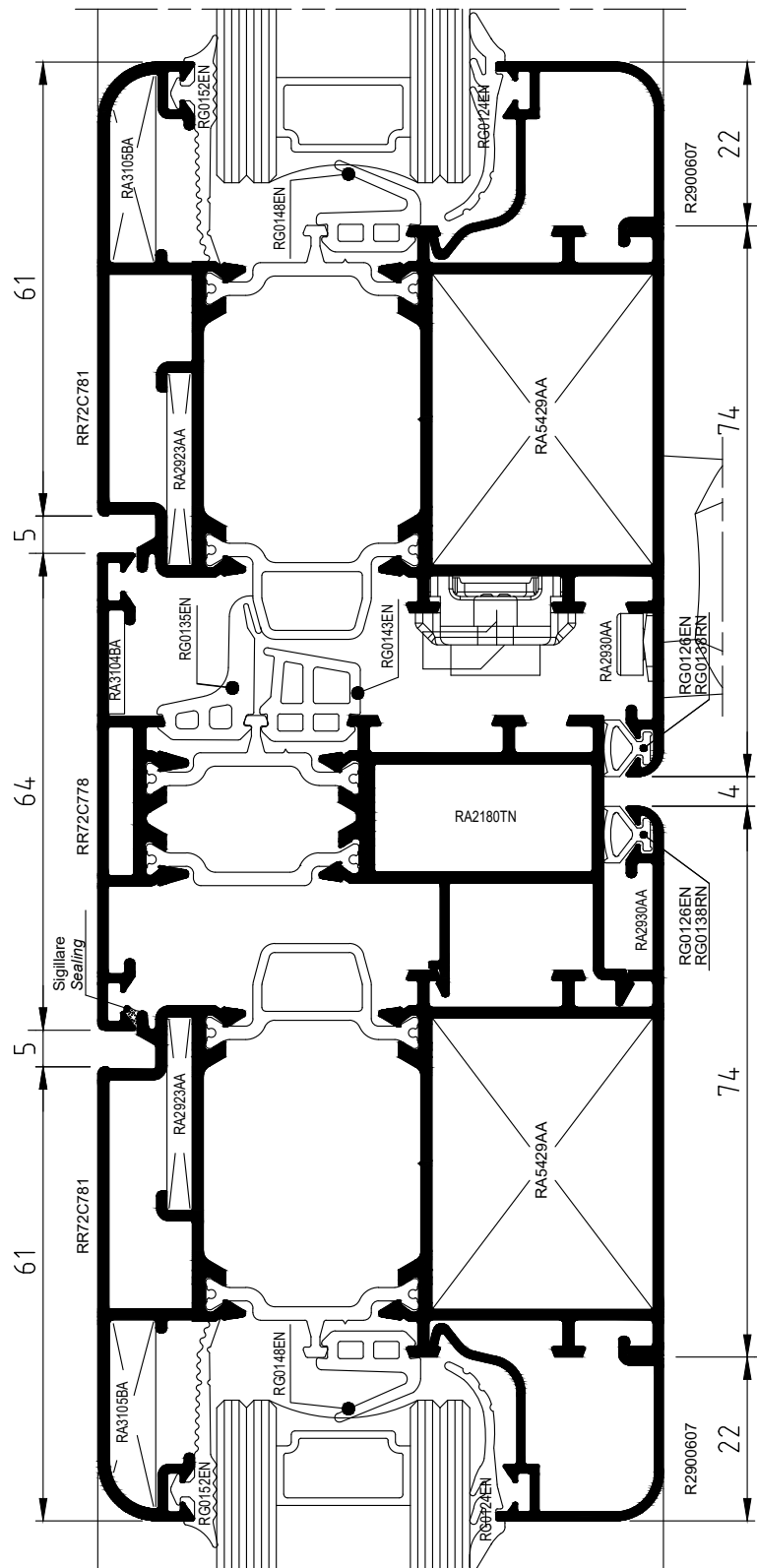
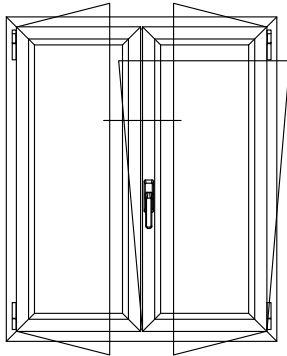

TUBOLARI ESTERNI RIDOTTI
REDUCED EXTERNAL TUBOLARS

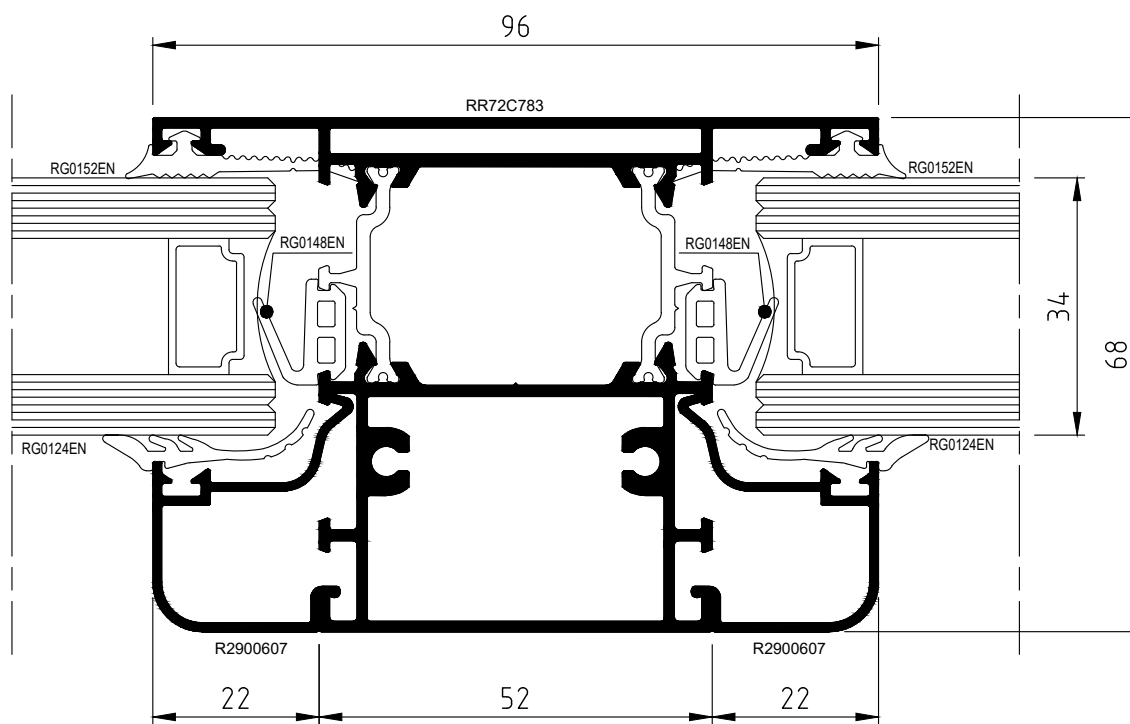
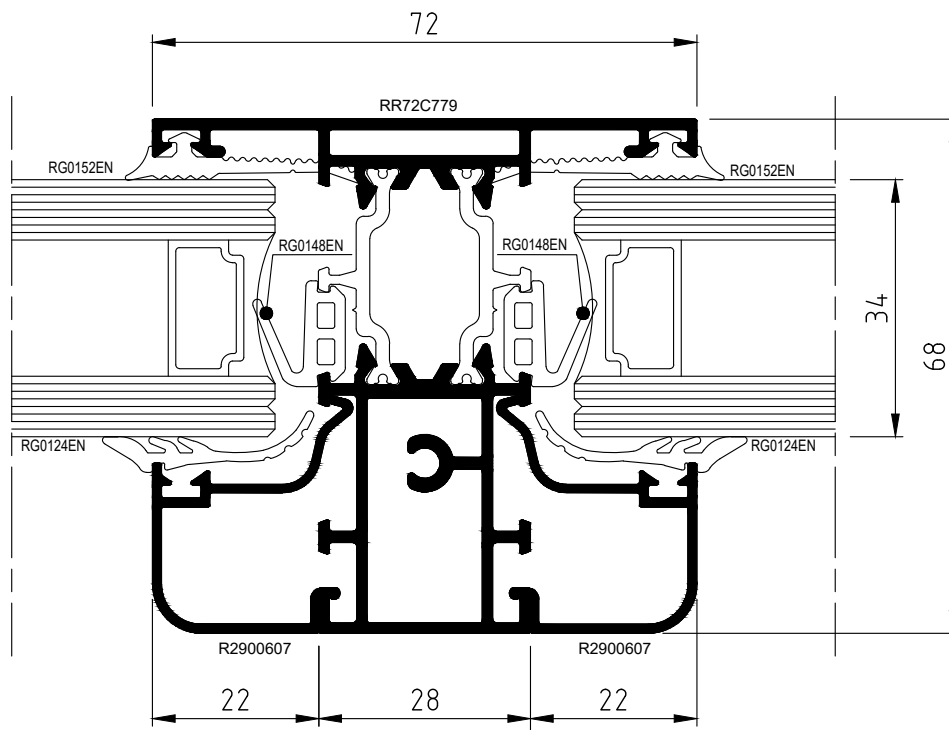

PORTA BALCONE
BALCONY DOOR

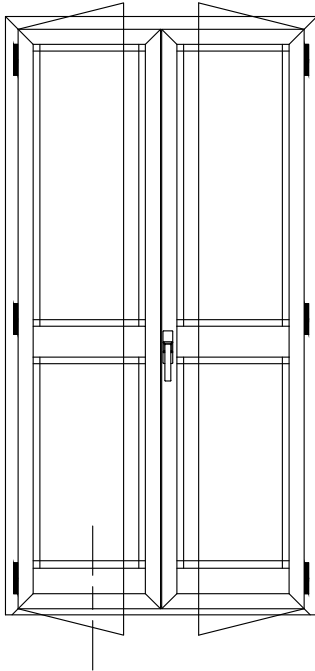

(x) Negli angoli a 45° le squadrette inserite nel tubolare esterno devono essere sempre incollate e cianfrinate. Cianfrinatura eseguibile anche con attrezzatura manuale Cod. M.2001.00
In the 45° corners, the corner joints in the external tubular section, must always be glued and caulked. Caulking may also be carried out by hand with equipment Art.M.2001.00

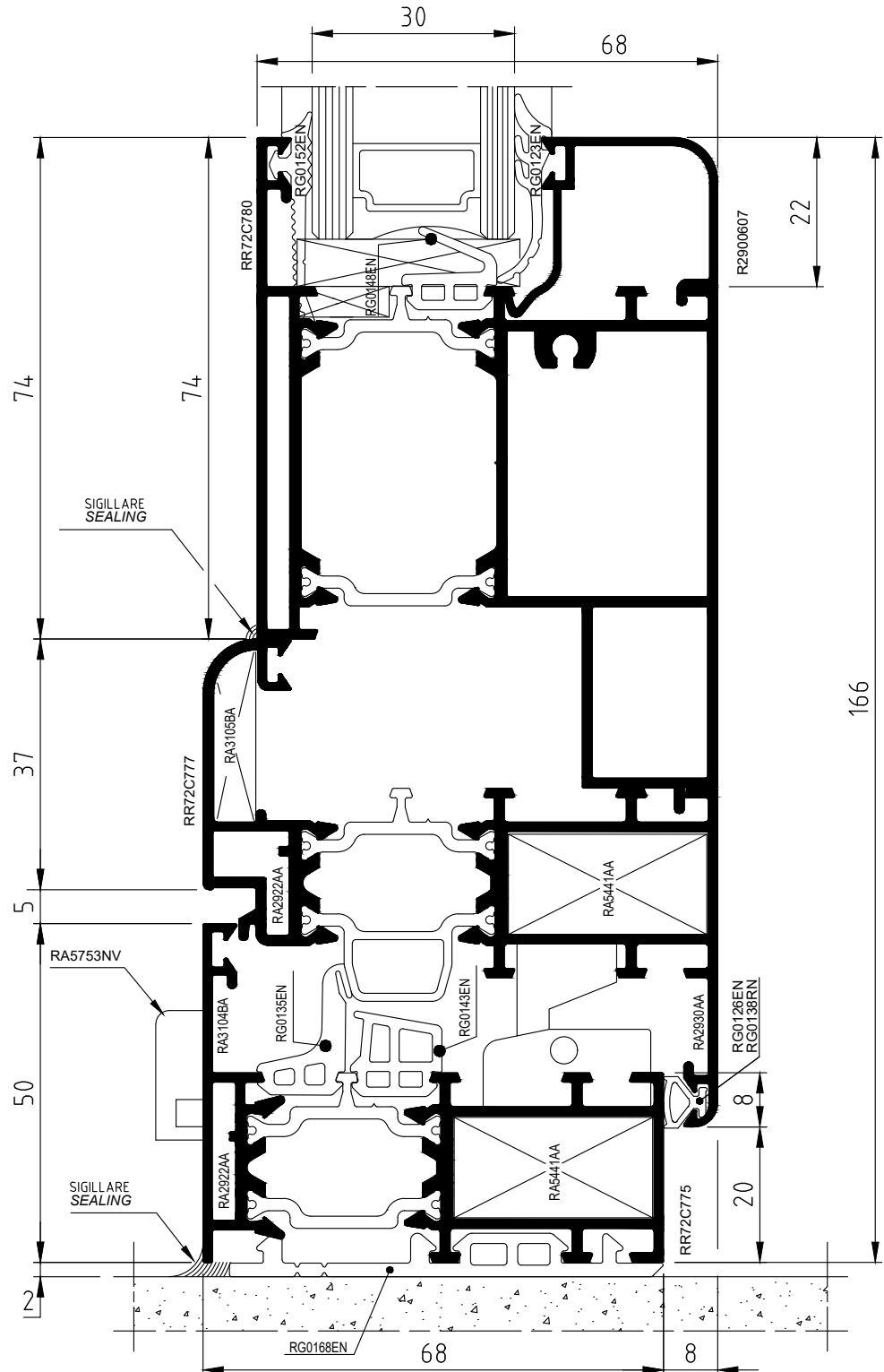

DISTINTE DI TAGLIO

CUT LIST

FINESTRA 1 ANTA
ONE-WING WINDOW

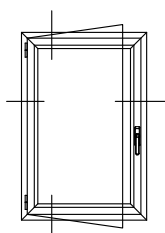

N.B.: - Le dimensioni di taglio e di lavorazione indicate nelle pagine seguenti sono state ottenute considerando le quote teoriche. Pertanto è necessario verificare sempre le dimensioni dei profilati prima di effettuare i tagli.
Hydro declina ogni responsabilità per errori dovuti al mancato controllo da parte del costruttore.

N.B.: - The cutting and processing dimensions, indicated in the following pages, are obtained considering theoretical values. It is, therefore, always necessary to check the dimensions of the profiles before executing the cutting.
Hydro declines any responsibility from errors caused from the missing dimensional check of the carpenter

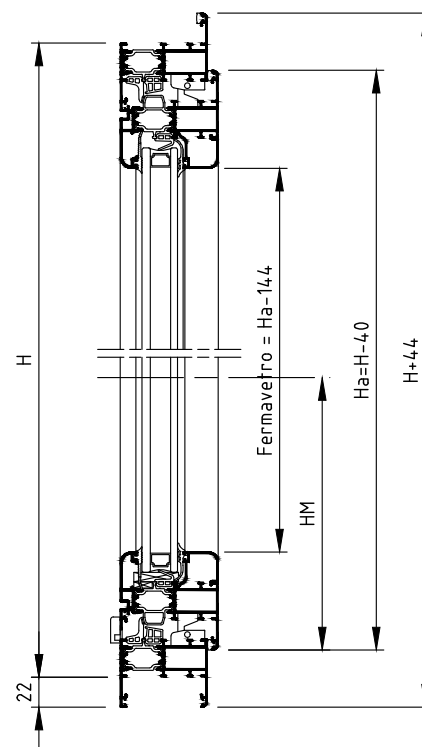
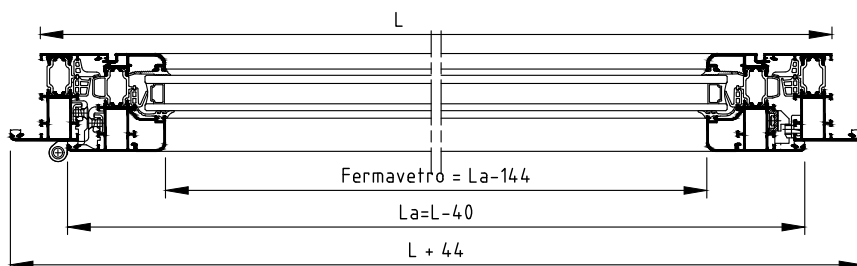

PROFILATI
SECTIONS

Profilato tipo Type Section	N° Pz.	Taglio Cut	N° Pz.	Taglio Cut
	2		1	
			1	
	2		2	
	2		2	
	1		1	

DIMENSIONI VETRO
GLASS SIZE

N. 1 PEZZO	N.B.: Spessore vetro considerato 26 mm (6+15+5) Gioco perimetrale tra profilato e vetro 5 mm For glass with 26 mm thickness Space between glass and profile 5 mm
Ha - 110	
La - 110	

ACCESSORI ACCESSORIES

Articolo Item	Descrizione Description	N	Articolo Item	Descrizione Description	N
RA3104BA	Squadretta Fuji allineamento aletta Fuji alignment corner joint on fin.	4	RA5532NN	Cappetta scarico acqua (paratempesta) Water drain cover	2
RA2930AA	Squadretta Fuji allineamento aletta Fuji alignment corner joint on fin.	8	RA5757ZA	Regolo mobile da 15 mm Adjustable block mm 15	5
RA3105BA	Squadretta Fuji all.mento aletta prof. compl. Fuji alignment corner joint for coplanar profiles	4	RA5765NN	Tappo rotondo copriforo diametro 12 mm Circular coverhole plug dia. mm 12	5
RA5441AA	Squadretta per giunzione d'angolo Corner joint	8	RA0228EN	Angolo stampato per precamera Moulded corner for central weatherstrip	4
RA5662AA	Squadretta a cianfrinare su prof. est. anta External corner joint to be crimped	4	RA0202BA	Angolo stampato per fermavetro arrotondato Moulded corner for snap-on rounded glass beading	4
RA2834AA	Supporto vetro Glass support	2			

GUARNIZIONI WEATHERSTRIPS

Articolo Item	Descrizione Description	N	Articolo Item	Descrizione Description	N
RG0126EN	Guarnizione di battuta Weatherstrip of rabbet	4H 3L	RG0152EN	Guarnizione esterna appoggio vetri 3 mm Weatherstrip on glass support mm 3	2H 2L
RG0123EN	Guarnizione interna tenuta vetro 4-6 mm Weatherstrip on glazing bead shim mm 4-6	2H 2L	RG0135EN	Guarnizione di precamera Central weatherstrip	2H 2L
RG0143EN	Guarnizione aggiuntiva di precamera Additional central Weatherstrip	2H 2L	RG0148EN	Guarnizione sotto vetro Weatherstrip under glass	2H 2L

FINESTRA 2 ANTE
TWO-WINGS WINDOW

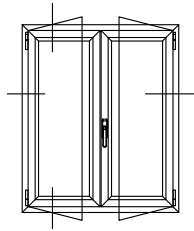

N.B: - Le dimensioni di taglio e di lavorazione indicate nelle pagine seguenti sono state ottenute considerando le quote teoriche.
Pertanto è necessario verificare sempre le dimensioni dei profilati prima di effettuare i tagli.
Hydro declina ogni responsabilità per errori dovuti al mancato controllo da parte del costruttore.

N.B: - The cutting and processing dimensions, indicated in the following pages, are obtained considering theoretical values.
It is, therefore, always necessary to check the dimensions of the profiles before executing the cutting.
Hydro declines any responsibility from errors caused from the missing dimensional check of the carpenter

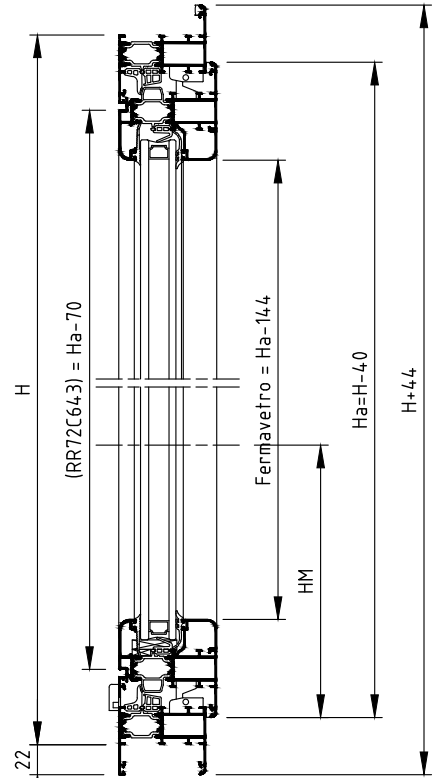
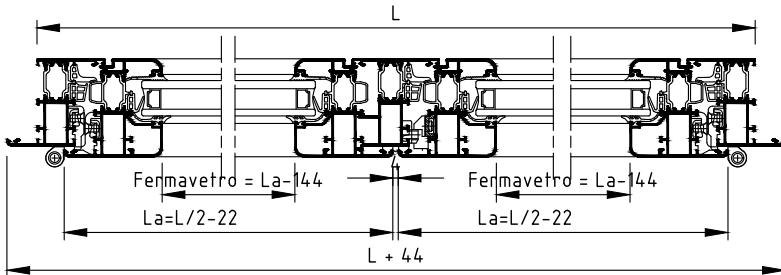

PROFILATI SECTIONS

Profilato tipo Type Section	N° Pz.	Taglio Cut	N° Pz.	Taglio Cut
	2		1	
			1	
	4		4	
	4		4	
	1			
	1		1	

DIMENSIONI VETRO GLASS SIZE

N. 2 PEZZI	N.B.: Spessore vetro considerato 26 mm (6+15+5) Gioco perimetrale tra profilato e vetro 5 mm For glass with 26 mm thickness Space between glass and profile 5 mm
Ha - 110	
La - 110	

ACCESSORI ACCESSORIES

Articolo Item	Descrizione Description	N	Articolo Item	Descrizione Description	N
RA3104BA	Squadretta Fuji allineamento aletta Fuji alignment corner joint on fin.	4	RA5532NN	Cappetta scarico acqua (paratempesta) Water drain cover	2
RA2930AA	Squadretta Fuji allineamento aletta Fuji alignment corner joint on fin.	12	RA5756ZA	Basetta unificata per regolo mobile Unified plate for adjustable block	5
RA3105BA	Squadretta Fuji all.mento aletta prof. compl. Fuji alignment corner joint for coplanar profiles	8	RA5757ZA	Regolo mobile da 15 mm Adjustable block mm 15	5
RA5441AA	Squadretta per giunzione d'angolo Corner joint	12	RA5765NN	Tappo rotondo copiforo diametro 12 mm Circular coverhole plug dia. mm 12	5
RA5662AA	Squadretta a cianfinare su prof. est. anta External corner joint to be crimped	8	RA0228EN	Angolo stampato per precamera Moulded corner for central weatherstrip	4
RA2834AA	Supporto vetro Glass support	4	RA0202BA	Angolo stampato per fermavetro arrotondato Moulded corner for snap-on rounded glass beading	8
RA2127TN	Coppia tappi per riporto centrale RR72C643 Pair of plugs for central rabbet on profile RR72C643	1			

GUARNIZIONI WEATHERSTRIPS

Articolo Item	Descrizione Description	N	Articolo Item	Descrizione Description	N
RG0126EN	Guarnizione di battuta Weatherstrip of rabbet	6H 3L	RG0152EN	Guarnizione esterna appoggio vetri 3 mm Weatherstrip on glass support mm 3	4H 2L
RG0123EN	Guarnizione interna tenuta vetro 4-6 mm Weatherstrip on glazing bead shim mm 4-6	4H 2L	RG0135EN	Guarnizione di precamera Central weatherstrip	3H 2L
RG0143EN	Guarnizione aggiuntiva di precamera Additional central Weatherstrip	3H 2L	RG0148EN	Guarnizione sotto vetro Weatherstrip under glass	4H 2L

FINESTRA 1 ANTA A RIBALTA
TILT AND TURN WINDOW

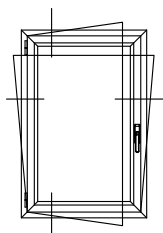

N.B.: - Le dimensioni di taglio e di lavorazione indicate nelle pagine seguenti sono state ottenute considerando le quote teoriche. Pertanto è necessario verificare sempre le dimensioni dei profilati prima di effettuare i tagli.
Hydro declina ogni responsabilità per errori dovuti al mancato controllo da parte del costruttore.

N.B.: - The cutting and processing dimensions, indicated in the following pages, are obtained considering theoretical values. It is, therefore, always necessary to check the dimensions of the profiles before executing the cutting.
Hydro declines any responsibility from errors caused from the missing dimensional check of the carpenter

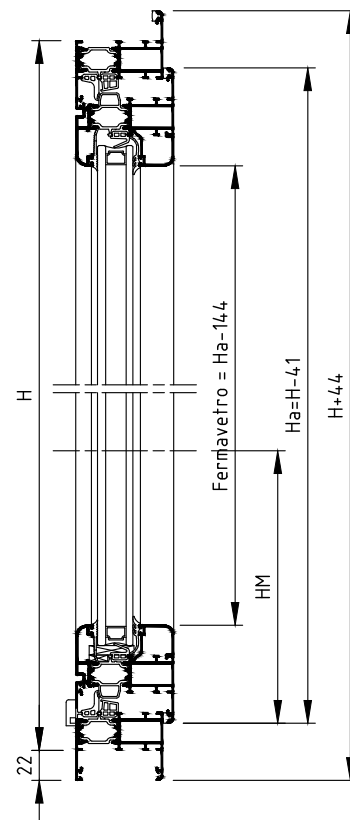
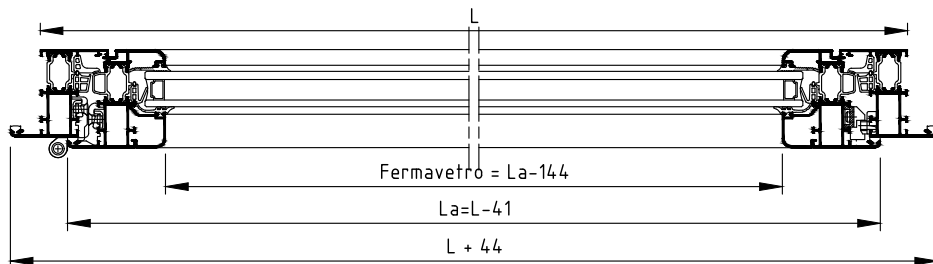

PROFILATI SECTIONS

Profilato tipo Type Section	N° Pz.	Taglio Cut	N° Pz.	Taglio Cut
	2		1	
			1	
	2		2	
	2		2	
	1	Verticale inferiore Lower Vertical 	1	Verticale Superiore Upper Vertical
			1	Orizzontale Superiore Upper Orizzontale

(*) = Valido per ante con La da 550 a 1200 mm ed Ha fino a 2800 mm. Per altre dimensioni ed ulteriori informazioni Vi preghiamo di consultare lo schema di montaggio contenuto nella confezione AR.

This for wings with L from 550 to 1200 mm and H up to 2800 mm. For other dimensions and further information please see processing scheme inside A/R box

Attenzione: in corrispondenza dei cardini inferiore e superiore utilizzare squadretta RA2919NN invece della RA2930AA
Attention: in correspondence of the bottom and upper hinges, use corner joint RA2919NN instead of RA2930AA

DIMENSIONI VETRO GLASS SIZE

N. 1 PEZZO	N.B.: Spessore vetro considerato 26 mm (6+15+5) Gioco perimetrale tra profilato e vetro 5 mm For glass with 26 mm thickness Space between glass and profile 5 mm
Ha - 110	
La - 110	

ACCESSORI ACCESSORIES

Articolo Item	Descrizione Description	N	Articolo Item	Descrizione Description	N	Articolo Item	Descrizione Description	N
RA3104BA	Squadretta Fuji allineamento aletta Fuji alignment corner joint on fin.	4	RA2834AA	Supporto vetro Glass support	2	RA0202BA	Angolo stampato per fermavetro arrotondato Moulded corner for snap-on rounded glass beading	4
RA2930AA	Squadretta Fuji allineamento aletta Fuji alignment corner joint on fin.	6	RA5532NN	Cappetta scarico acqua (paratempsta) Water drain cover	2			
RA2919NN	Squadretta allineamento aletta Alignment corner joint on fin.	2	RA5756ZA	Basetta unificata per regolo mobile Unified plate for adjustable block	5			
RA3105BA	Squadretta Fuji all.mento aletta prof. compl. Fuji alignment corner joint for coplanar profiles	4	RA5757ZA	Regolo mobile da 15 mm Adjustable block mm 15	5			
RA5441AA	Squadretta per giunzione d'angolo Corner joint	8	RA5765NN	Tappo rotondo copriforo diametro 12 mm Circular coverhole plug dia. mm 12	5			
RA5662AA	Squadretta a cianfinare su prof. est. anta External corner joint to be crimped	4	RA0228EN	Angolo stampato per precamera Moulded corner for central weatherstrip	4			

GUARNIZIONI WEATHERSTRIPS

Articolo Item	Descrizione Description	N	Articolo Item	Descrizione Description	N
RG0126EN	Guarnizione di battuta Weatherstrip of rabbit	4H 3L	RG0152EN	Guarnizione esterna appoggio vetri 3 mm Weatherstrip on glass support mm 3	2H 2L
RG0123EN	Guarnizione interna tenuta vetro 4-6 mm Weatherstrip on glazing bead shim mm 4-6	2H 2L	RG0135EN	Guarnizione di precamera Central weatherstrip	2H 2L
RG0143EN	Guarnizione aggiuntiva di precamera Additional central Weatherstrip	2H 2L	RG0148EN	Guarnizione sotto vetro Weatherstrip under glass	2H 2L

FINESTRA 2 ANTE
CON ANTA RIBALTA
WING WINDOW - OVERLAP
AND TILT-AND-TURN

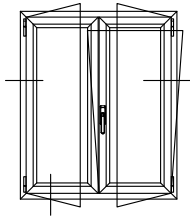

N.B: - Le dimensioni di taglio e di lavorazione indicate nelle pagine seguenti sono state ottenute considerando le quote teoriche. Pertanto è necessario verificare sempre le dimensioni dei profilati prima di effettuare i tagli.
Hydro declina ogni responsabilità per errori dovuti al mancato controllo da parte del costruttore.

N.B: - The cutting and processing dimensions, indicated in the following pages, are obtained considering theoretical values. It is, therefore, always necessary to check the dimensions of the profiles before executing the cutting.
Hydro declines any responsibility from errors caused from the missing dimensional check of the carpenter

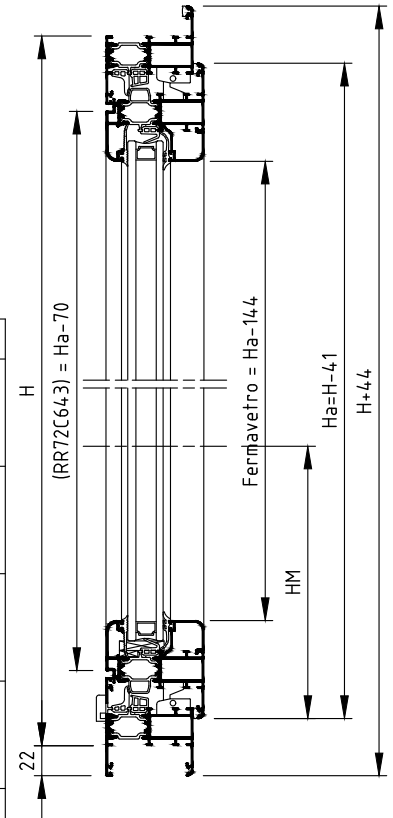
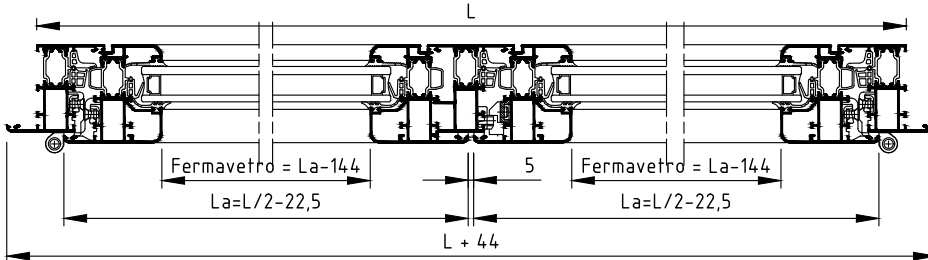

PROFILATI SECTIONS

Profilato tipo Type Section	N° Pz.	Taglio Cut	N° Pz.	Taglio Cut
	2		1	
	1		1	
	4		4	
	4		4	
	1			
	1	Verticale inferiore Lower Vertical 	1	Verticale Superiore Upper Vertical
	1	Orizzontale Superiore Upper Horizontal 		

DIMENSIONI VETRO GLASS SIZE

N. 1 PEZZO	N.B.: Spessore vetro considerato 26 mm (6+15+5) Gioco perimetrale tra profilato e vetro 5 mm For glass with 26 mm thickness Space between glass and profile 5 mm
Ha - 110	
La - 110	

(*) = Valido per ante con La da 550 a 1200 mm ed Ha fino a 2800 mm. Per altre dimensioni ed ulteriori informazioni Vi preghiamo di consultare lo schema di montaggio contenuto nella confezione AR.

This for wings with L from 550 to 1200 mm and H up to 2800 mm. For other dimensions and further information please see processing scheme inside A/R box

Attenzione: in corrispondenza dei cardini inferiori e superiori utilizzare squadretta RA2919NN invece della RA2930AA

Attention: in correspondence of the bottom and upper hinges, use corner joint RA2919NN instead of RA2930AA

ACCESSORI ACCESSORIES

Articolo Item	Descrizione Description	N	Articolo Item	Descrizione Description	N
RA3104BA	Squadretta Fuji allineamento aletta Fuji alignment corner joint on fin.	4	RA2834AA	Supporto vetro Glass support	4
RA2930AA	Squadretta Fuji allineamento aletta Fuji alignment corner joint on fin.	8	RA5532NN	Cappetta scarico acqua (paratempesta) Water drain cover	2
RA2919NN	Squadretta allineamento aletta Alignment corner joint on fin.	4	RA5756ZA	Basetta unificata per regolo mobile Unified plate for adjustable block	5
RA3105BA	Squadretta Fuji all.mento aletta prof. compl. Fuji alignment corner joint for coplanar profiles	8	RA5757ZA	Regolo mobile da 15 mm Adjustable block mm 15	5
RA5662AA	Squadretta a cianfrinare su prof. est. anta External corner joint to be crimped	8	RA5765NN	Tappo rotondo copriforo diametro 12 mm Circular coverhole plug dia. mm 12	5
RA5441AA	Squadretta per giunzione d'angolo Corner joint	12	RA0228EN	Angolo stampato per precamera Moulded corner for central weatherstrip	4
RA2127TN	Coppia tappi per riporto centrale RR72C643 Pair of plugs for central rabbet on profile RR72C643	1	RA0202BA	Angolo stampato per fermavetro arrotondato Moulded corner for snap-on rounded glass beading	8

GUARNIZIONI WEATHERSTRIPS

Articolo Item	Descrizione Description	N	Articolo Item	Descrizione Description	N	Articolo Item	Descrizione Description	N
RG0126EN	Guarnizione di battuta Weatherstrip of rabbet	6H 3L	RG0143EN	Guarnizione aggiuntiva di precamera Additional central Weatherstrip	3H 2L	RG0135EN	Guarnizione di precamera Central weatherstrip	3H 2L
RG0123EN	Guarnizione interna tenuta vetro 4-6 mm Weatherstrip on glazing bead shim mm 4-6	4H 2L	RG0152EN	Guarnizione esterna appoggio vetri 3 mm Weatherstrip on glass support mm 3	4H 2L	RG0148EN	Guarnizione sotto vetro Weatherstrip under glass	4H 2L

FINESTRA SPORGERE
PROJECTING WINDOW

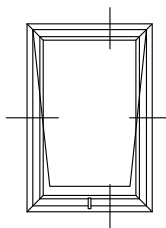

N.B: - Le dimensioni di taglio e di lavorazione indicate nelle pagine seguenti sono state ottenute considerando le quote teoriche. Pertanto è necessario verificare sempre le dimensioni dei profilati prima di effettuare i tagli.
Hydro declina ogni responsabilità per errori dovuti al mancato controllo da parte del costruttore.

N.B: - The cutting and processing dimensions, indicated in the following pages, are obtained considering theoretical values. It is, therefore, always necessary to check the dimensions of the profiles before executing the cutting.
Hydro declines any responsibility from errors caused from the missing dimensional check of the carpenter

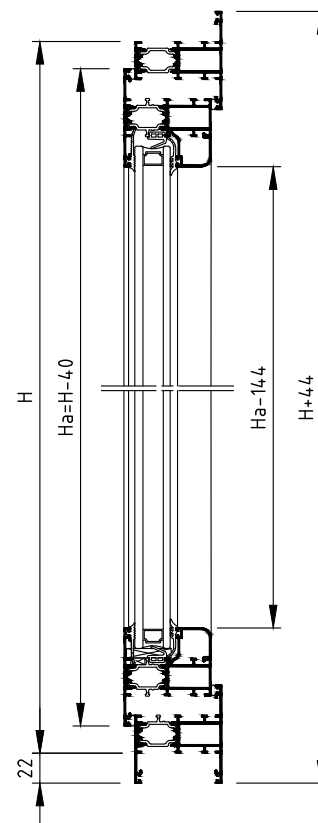
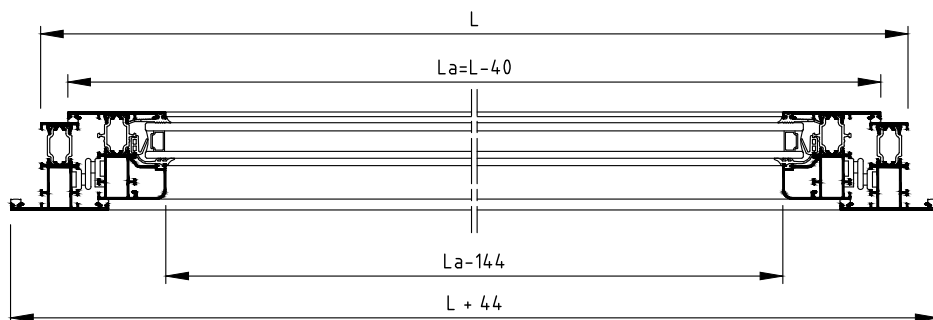

PROFILATI SECTIONS

Profilato tipo Type Section	N° Pz.	Taglio Cut	N° Pz.	Taglio Cut
	2		1	
			1	
	2		2	
	2		2	

DIMENSIONI VETRO GLASS SIZE

N.B.: Spessore vetro considerato
26 mm (6+15+5)
Gioco perimetrale tra
profilato e vetro 5 mm
For glass with 26 mm thickness
Space between glass
and profile 5 mm

N. 1 PEZZO

Ha - 110

La - 110

ACCESSORI ACCESSORIES

Articolo Item	Descrizione Description	N	Articolo Item	Descrizione Description	N
RA2930AA	Squadretta Fuji allineamento aletta Fuji alignment corner joint on fin.	8	RA0202BA	Angolo stampato per fermavetro arrotondato Moulded corner for snap-on rounded glass beading	4
RA3105BA	Squadretta Fuji allineamento aletta Fuji alignment corner joint on fin.	8	RA2834AA	Supporto vetro Glass support	2
RA5441AA	Squadretta per giunzione d'angolo Corner joint	8			
RA5756ZA	Basetta unificata per regolo mobile Unified plate for adjustable block	5			
RA5757ZA	Regolo mobile da 15 mm Adjustable block mm 15	5			
RA5765NN	Tappo rotondo copriforo diametro 12 mm Circular coverhole plug dia. mm 12	5			

GUARNIZIONI WEATHERSTRIPS

Articolo Item	Descrizione Description	N	Articolo Item	Descrizione Description	N
RG0126EN	Guarnizione di battuta Weatherstrip of rabbet	6H 5L	RG0152EN	Guarnizione esterna appoggio vetri 3 mm Weatherstrip on glass support mm 3	2H 2L
RG0123EN	Guarnizione interna tenuta vetro 4-6 mm Weatherstrip on glazing bead shim mm 4-6	2H 2L	RG0148EN	Guarnizione sotto vetro Weatherstrip under glass	4H 2L

FINESTRA VASISTAS
OVERLAP HOPPER WINDOW

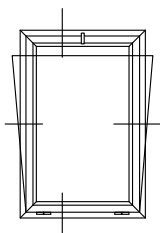

N.B.: - Le dimensioni di taglio e di lavorazione indicate nelle pagine seguenti sono state ottenute considerando le quote teoriche. Pertanto è necessario verificare sempre le dimensioni dei profilati prima di effettuare i tagli.
Hydro declina ogni responsabilità per errori dovuti al mancato controllo da parte del costruttore.

N.B.: - The cutting and processing dimensions, indicated in the following pages, are obtained considering theoretical values. It is, therefore, always necessary to check the dimensions of the profiles before executing the cutting.
Hydro declines any responsibility from errors caused from the missing dimensional check of the carpenter

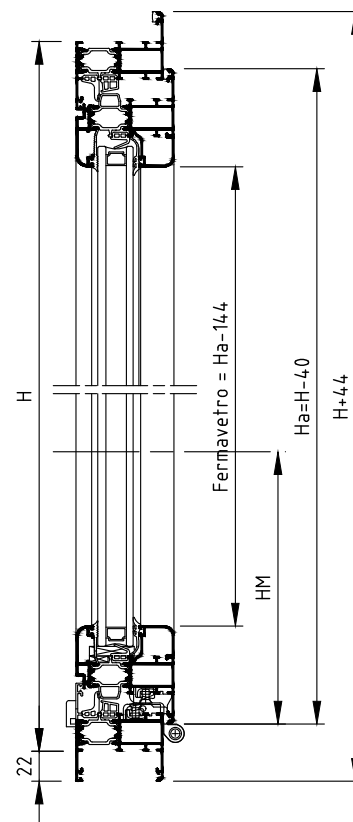
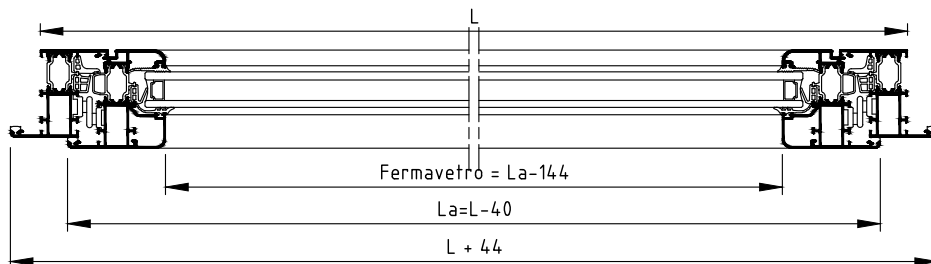

PROFILATI SECTIONS

Profilato tipo Type Section	N° Pz.	Taglio Cut	N° Pz.	Taglio Cut
	2		1	
			1	
	2		2	
			2	

DIMENSIONI VETRO GLASS SIZE

N. 1 PEZZO	N.B.: Spessore vetro considerato 26 mm (6+15+5) Gioco perimetrale tra profilato e vetro 5 mm For glass with 26 mm thickness Space between glass and profile 5 mm
Ha - 110	
La - 110	

ACCESSORI ACCESSORIES

Articolo Item	Descrizione Description	N	Articolo Item	Descrizione Description	N
RA3104BA	Squadretta Fuji allineamento aletta Fuji alignment corner joint on fin.	4	RA5756ZA	Basetta unificata per regolo mobile Unified plate for adjustable block	5
RA2930AA	Squadretta Fuji allineamento aletta Fuji alignment corner joint on fin.	8	RA5757ZA	Regolo mobile da 15 mm Adjustable block mm 15	5
RA3105BA	Squadretta Fuji all.mento aletta prof. compl. Fuji alignment corner joint for coplanar profiles	4	RA5765NN	Tappo rotondo copriforo diametro 12 mm Circular coverhole plug dia. mm 12	5
RA5441AA	Squadretta per giunzione d'angolo Corner joint	8	RA0228EN	Angolo stampato per precamera Moulded corner for central weatherstrip	4
RA2834AA	Supporto vetro Glass support	2	RA0202BA	Angolo stampato per fermavetro arrotondato Moulded corner for snap-on rounded glass beading	4
RA5532NN	Cappetta scarico acqua (paratempsta) Water drain cover	2			

GUARNIZIONI WEATHERSTRIPS

Articolo Item	Descrizione Description	N	Articolo Item	Descrizione Description	N
RG0126EN	Guarnizione di battuta Weatherstrip of rabbet	4H 3L	RG0152EN	Guarnizione esterna appoggio vetri 3 mm Weatherstrip on glass support mm 3	2H 2L
RG0123EN	Guarnizione interna tenuta vetro 4-6 mm Weatherstrip on glazing bead shim mm 4-6	2H 2L	RG0135EN	Guarnizione di precamera Central weatherstrip	2H 2L
RG0143EN	Guarnizione aggiuntiva di precamera Additional central Weatherstrip	2H 2L	RG0148EN	Guarnizione sotto vetro Weatherstrip under glass	2H 2L

PORTA
BALCONE 1 ANTA

ONE-WING
BALCONY DOOR

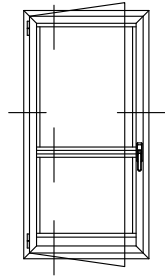

N.B.: - Le dimensioni di taglio e di lavorazione indicate nelle pagine seguenti sono state ottenute considerando le quote teoriche. Pertanto è necessario verificare sempre le dimensioni dei profilati prima di effettuare i tagli.
Hydro declina ogni responsabilità per errori dovuti al mancato controllo da parte del costruttore.

N.B.: - The cutting and processing dimensions, indicated in the following pages, are obtained considering theoretical values. It is, therefore, always necessary to check the dimensions of the profiles before executing the cutting.
Hydro declines any responsibility from errors caused from the missing dimensional check of the carpenter

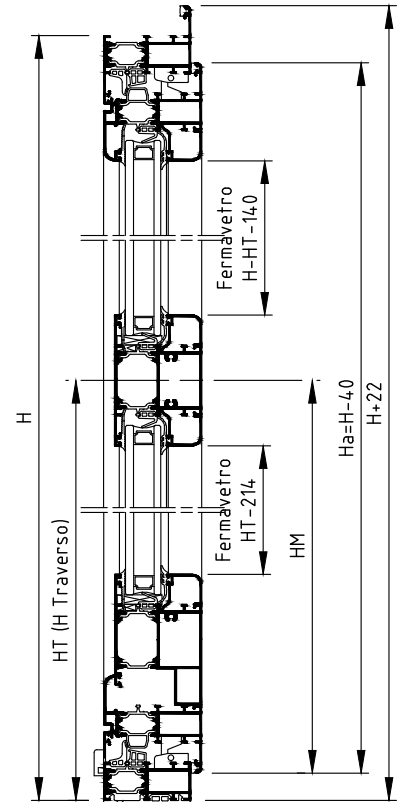
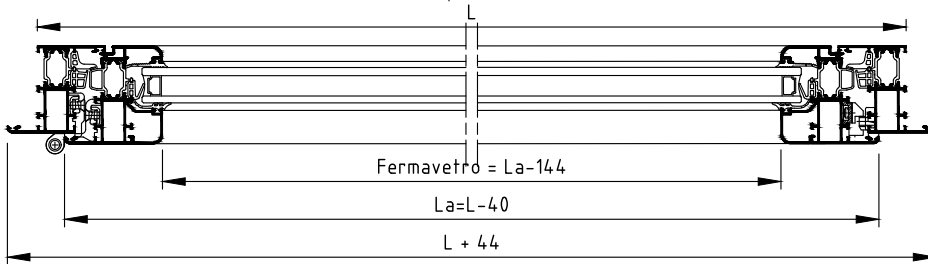

PROFILATI SECTIONS

Profilato tipo Type Section	N° Pz.	Taglio Cut	N° Pz.	Taglio Cut		
	1		1			
	1					
			1			
	2		2			
			1			
			1			
	2		2		4	
	1		1			

DIMENSIONE VETRO GLASS SIZE

N. 1 PEZZO	N.B.: Spessore vetro considerato 26 mm (6+15+5)
HT - 180	Gioco perimetrale tra profilato e vetro 5 mm
La - 110	For glass with 26 mm thickness
	Space between glass and profile 5 mm
N. 1 PEZZO	
H - HT - 106	
La - 110	

ACCESSORI ACCESSORIES

Articolo Item	Descrizione Description	N	Articolo Item	Descrizione Description	N	Articolo Item	Descrizione Description	N
RA3104BA	Squadretta Fuji allineamento aletta Fuji alignment corner joint on fin.	4	RA3207AA	Giunto a "T" in alluminio estruso Extruded aluminium T joint	2	RA5757ZA	Regolo mobile da 15 mm Adjustable block mm 15	8
RA2930AA	Squadretta Fuji allineamento aletta Fuji alignment corner joint on fin.	6	RA4003ZX	Cremonese reversibile per ap. int. Reversible cremonese bolt for internal opening	1	RA5765NN	Tappo rotondo copriforo diametro 12 mm Circular coverhole plug dia. mm 12	8
RA3105BA	Squadretta Fuji all.mento aletta prof. compl. Fuji alignment corner joint for coplanar profiles	4	RA5746VV	Riscontro registrabile per puntali RA5772VV Adjustable striker for terminals RA5772VV	2	RA0228EN	Angolo stampato per precamera Moulded corner for central weatherstrip	4
RA5441AA	Squadretta per giunzione d'angolo Corner joint	8	RA2834AA	Supporto vetro Glass support	4	RA0202BA	Angolo stampato per fermavetro arrotondato Moulded corner for snap-on rounded glass beading	8
RA5662AA	Squadretta a cianfinare su prof. est. anta External corner joint to be crimped	4	RA5532NN	Cappetta scarico acqua (paratempesta) Water drain cover	2	RA3204ZA	Cavallotto di giunzione tela-traversi Tjoint for frames and transoms	6
RA1035AX	Cerniera sfilabile con controp.ra in acc. inox Slip-of hinge with stainless steel counterplate	3	RA5756ZA	Basetta unificata per regolo mobile Unified plate for adjustable block	8			

GUARNIZIONI WEATHERSTRIPS

Articolo Item	Descrizione Description	N	Articolo Item	Descrizione Description	N	Articolo Item	Descrizione Description	N
RG0126EN	Guarnizione di battuta Weatherstrip of rabbet	4H 3L	RG0135EN	Guarnizione di precamera Central weatherstrip	2H 2L	RG0168EN	Guarnizione isolamento termico telaio-muro Weatherstrip thermal insulation frame-wall	1L
RG0123EN	Guarnizione interna tenuta vetro 4-6 mm Weatherstrip on glazing bead shim mm 4-6	2H 4L	RG0143EN	Guarnizione aggiuntiva di precamera Additional central Weatherstrip	3H 2L			
RG0152EN	Guarnizione esterna appoggio vetri 3 mm Weatherstrip on glass support mm 3	2H 4L	RG0148EN	Guarnizione sotto vetro Weatherstrip under glass	4H 2L			

FINESTRA 2 ANTE
CON ANTA RIBALTA
WING WINDOW - OVERLAP
AND TILT-AND-TURN

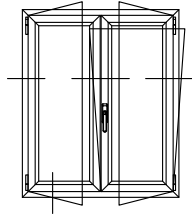

N.B.: - Le dimensioni di taglio e di lavorazione indicate nelle pagine seguenti sono state ottenute considerando le quote teoriche. Pertanto è necessario verificare sempre le dimensioni dei profilati prima di effettuare i tagli.
Hydro declina ogni responsabilità per errori dovuti al mancato controllo da parte del costruttore.
N.B.: - The cutting and processing dimensions, indicated in the following pages, are obtained considering theoretical values. It is, therefore, always necessary to check the dimensions of the profiles before executing the cutting.
Hydro declines any responsibility from errors caused from the missing dimensional check of the carpenter

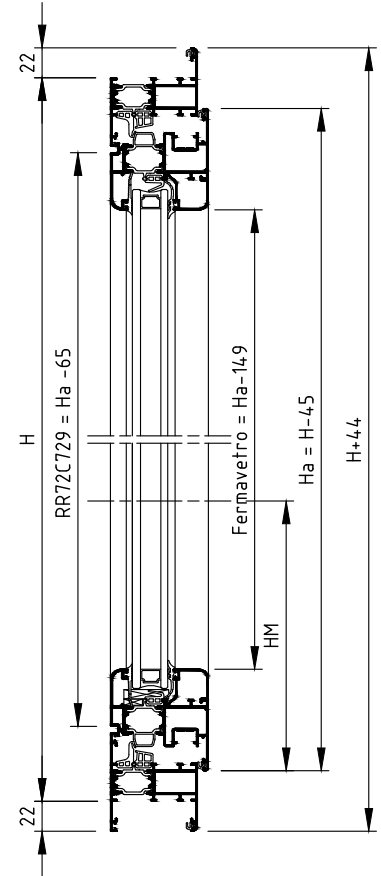
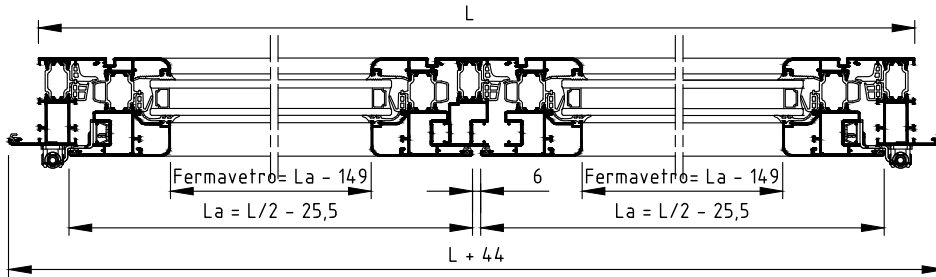

PROFILATI
SECTIONS

Profilato Section	N° Pz.	Taglio Cut	N° Pz.	Taglio Cut
	2	 H + 44	1	 L + 44
			1	 L + 44
	4	 Ha = H - 45	4	 La = L/2 - 25,5
	1	 Ha - 65		
	4	 Ha - 149	4	 La - 149

DIMENSIONE VETRI GLASSES SIZE

N. 2 PEZZI N.B.: Spessore vetro considerato 30 mm (6+15+4/4)
Gioco perimetrale tra profilato e vetro 5 mm
For glass with 30 mm thickness
Space between glass and profile 5 mm

(*) Accessori da stabilire in funzione delle dimensioni dell'anta. Consultare catalogo Maico.
(*) Accessories to be established according to wing-dimension, please see catalogue Maico
Attenzione: in corrispondenza dei cardini inferiori utilizzare squadretta RA3103ZA invece della 2021 (Mont.)
Attention: in correspondence of the bottom hinges use corner joint RA3103ZA instead of 2021 (Mont.)

ACCESSORI ACCESSORIES

ARTICOLO ITEM	DESCRIZIONE DESCRIPTION	N.	ARTICOLO ITEM	DESCRIZIONE DESCRIPTION	N.	ARTICOLO ITEM	DESCRIZIONE DESCRIPTION	N.
RA5441AA	Squadretta d'angolo Corner joint	4	462687	Kit ante con anta ribalta Multi-Matic Kit wings with tilt-and-turn Multi-Matic	1	RA2137TN	Coppia tappi per riporto centrale RR72C729 Pair of plugs for central rabbet on profile RR72C729	1
RA2935BA	Squadretta d'angolo Corner joint	8	201745(x)	Cremonese Multi Matic Cremonese bolt Multi Matic	1	RA5532NN	Cappetta scarico acqua (paratempesta) Water drain cover	2
RA3105BA	Squadretta di allineamento prof. compl "FUJI" Alignment corner joint coplanar profiles "FUJI"	8	201751(x)	Chiusura centrale Multi Matic Centre lock Multi Matic	1	RA5756ZA	Basetta per regolo mobile Plate for adjustable block	5
RA2930AA	Squadretta di allineamento "FUJI" Alignment corner joint "FUJI"	4	206864(x)	Frontale forcice Multi Matic Face plate scissor Multi Matic	1	RA5757ZA	Regolo mobile da 15 mm Adjustable block mm 15	5
RA3104BA	Squadretta di allineamento "FUJI" Alignment corner joint "FUJI"	4	207123(x)	Braccio forcice Multi Matic Hinged scissor Multi Matic	1	RA5765NN	Tappo rotondo copriforo diametro 12 mm Circular coverhole plug dia. mm 12	5
R2021	Squadretta di allineamento int. "FUJI" Internal alignment corner joint "FUJI"	6	221911(x)	Asta a leva Multi Matic Bar overlapping Multi Matic	1	RA0202BA	Angolo stampato per fermavetro arrotondato Moulded corner for snap-on rounded glass beading	8
RA2910AA	Squadretta a cianfr./spinare su prof. est. anta External corner joint to be crimped or pinned	8	59515	Maniglia rhapsody titanio Handle rhapsody Titanium	1	RA0228EN	Angolo stampato per precamera Moulded corner for central weatherstrip	4
RA3103ZA	Squadretta aletta anta "ferramenta perimetrale" Corner joint "to perimetral fitting solution"	2	Per accessori e portate non indicate consultare il catalogo del costruttore. For accessories and loaded not indicated, please refer the construction catalogue.			RA2834AA	Supporto vetro Glass support	4

GUARNIZIONI WEATHERSTRIPS

ARTICOLO ITEM	DESCRIZIONE DESCRIPTION	N.	ARTICOLO ITEM	DESCRIZIONE DESCRIPTION	N.	ARTICOLO ITEM	DESCRIZIONE DESCRIPTION	N.
RG0154EN	Guarnizione di battuta Weatherstrip of rabbet	6H 3L	RG0152EN	Guarnizione esterna vetri da 3 mm mm 5 glass support external weatherstrip	4H 2L	RG0143EN	Guarnizione aggiuntiva di precamera Additional central weatherstrip	3H 2L
RG0135EN	Guarnizione di precamera Central Weatherstrip	3H 2L	RG0149EN	Guarnizione su fermavetro spessore 4 mm Weatherstrip on glazing bead shim mm 4	4H 2L	RG0148EN	Guarnizione sotto vetro Weatherstrip under glass	4H 2L

BILICO ORIZZONTALE
HORIZONTAL PIVOTING
WINDOW

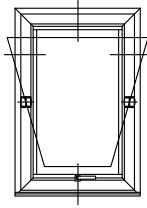

N.B.: - Le dimensioni di taglio e di lavorazione indicate nelle pagine seguenti sono state ottenute considerando le quote teoriche. Pertanto è necessario verificare sempre le dimensioni dei profilati prima di effettuare i tagli.
Hydro declina ogni responsabilità per errori dovuti al mancato controllo da parte del costruttore.

N.B.: - The cutting and processing dimensions, indicated in the following pages, are obtained considering theoretical values. It is, therefore, always necessary to check the dimensions of the profiles before executing the cutting.
Hydro declines any responsibility from errors caused from the missing dimensional check of the carpenter

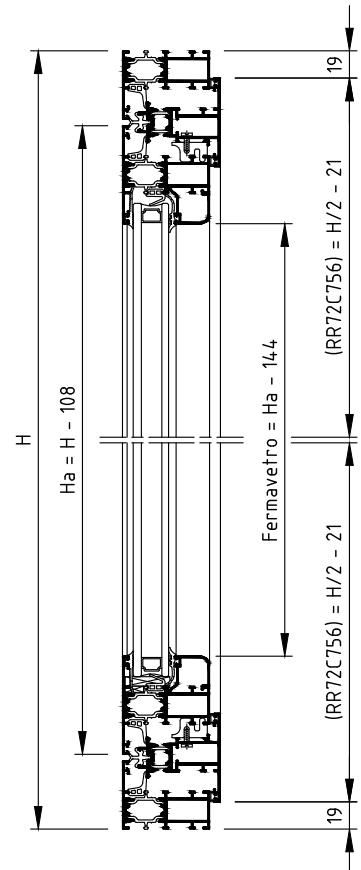
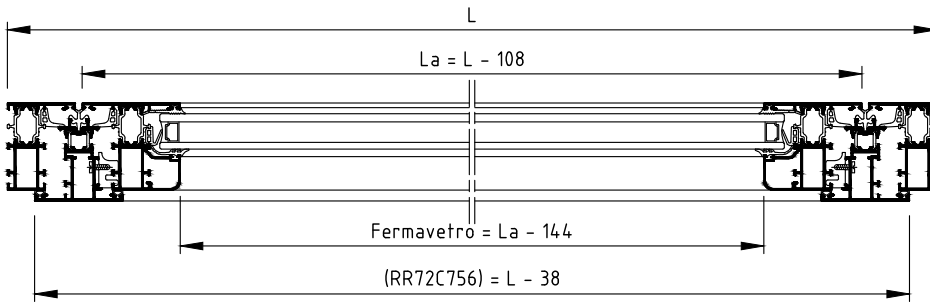

PROFILATI SECTIONS

Profilato tipo Type Section	N° Pz.	Taglio Cut	N° Pz.	Taglio Cut
	2	H	2	L
	2	H/2 - 21 (H/2 - 21.5)	2	L - 38 (L - 39)
	2	H/2 - 21 (H/2 - 21.5)		
	2	Ha = H - 108 (Ha = H - 109)	2	La = L - 108 (La = L - 109)
	2	Ha - 144	2	La - 144
	2	H	2	L

N.B.: tra parentesi le quote con le quali consigliamo di effettuare il taglio dei profilati
In brackets you will find the indications of the profiles cutting length we suggest

* Per lavorazioni, taglio astine e montaggio accessori, consultare la tavola specifica del costruttore
For machining, cutting rods and mounting accessories, refer to the manufacturer's specification table

DIMENSIONI VETRO GLASS SIZE

N. 1 PEZZO N.B.: Spessore vetro considerato 26 mm (6+15+5)
Gioco perimetrale tra profilato e vetro 5 mm
For glass with 26 mm thickness
Space between glass and profile 5 mm

ACCESSORI ACCESSORIES

Articolo Item	Descrizione Description	N	Articolo Item	Descrizione Description	N	Articolo Item	Descrizione Description	N
408.213.XX	Kit bilico orizzontale a chiusure multiple Kit multi-point lockings horizontal pivoting window	1	RA2834AA	Supporto vetro Glass support	2	RA0228EN	Angolo stampato per precamera Moulded corner for central weatherstrip	4
508.025.01	Distanziale fissaggio profilo inversione bilico Spacer for fixing profile inversion pivoting window	*	RA5532NN	Cappetta scarico acqua (paratempesta) Water drain cover	2	RA0202BA	Angolo stampato per fermavetro arrotondato Moulded corner for snap-on rounded glass beading	4
RA3104BA	Squadretta Fuji allineamento aletta Fuji alignment corner joint on fin.	10	RA5756ZA	Basetta unificata per regolo mobile Unified plate for adjustable block	5	RA5726VV	Kit chiusura supplementare Kit additional lock	*
RA2930AA	Squadretta Fuji allineamento aletta Fuji alignment corner joint on fin.	6	RA5757ZA	Regolo mobile da 15 mm Adjustable block mm 15	5	RA2156TN	Tappo per giunzione bilico Plug for pivoting window connection	1
RA5441AA	Squadretta per giunzione d'angolo Corner joint	12	RA5765NN	Tappo rotondo copriforo diametro 12 mm Circular coverhole plug dia. mm 12	5			

GUARNIZIONI WEATHERSTRIPS

Articolo Item	Descrizione Description	N	Articolo Item	Descrizione Description	N	Articolo Item	Descrizione Description	N
RG0126EN	Guarnizione di battuta Weatherstrip of rabbit	4H 4L	RG0152EN	Guarnizione esterna appoggio vetri 3 mm Weatherstrip on glass support mm 3	2H 2L	RG0148EN	Guarnizione sotto vetro Weatherstrip under glass	2H 2L
RG0123EN	Guarnizione interna tenuta vetro 4-6 mm Weatherstrip on glazing bead shim mm 4-6	2H 2L	RG0135EN	Guarnizione di precamera Central weatherstrip	4H 4L	RG0119EN	Guarnizione di battuta per bilico pivoting weatherstrip of rabbit	2H 2L

MONOBLOCCO
MONOBLOCK

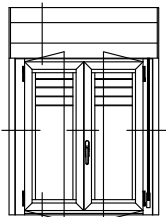

N.B.: - Le dimensioni di taglio e di lavorazione indicate nelle pagine seguenti sono state ottenute considerando le quote teoriche.
Pertanto è necessario verificare sempre le dimensioni dei profilati prima di effettuare i tagli.
Sapa declina ogni responsabilità per errori dovuti al mancato controllo da parte del costruttore.

N.B.: - The cutting and processing dimensions, indicated in the following pages, are obtained considering theoretical values.
It is, therefore, always necessary to check the dimensions of the profiles before executing the cutting.
Sapa declines any responsibility from errors caused from the missing dimensional check of the carpenter

PROFILATI SECTIONS

Profilato Section	N° Pz.	Taglio Cut	N° Pz.	Taglio Cut
	2	H + 20		
	2	H + 20		
			1	L + 53
			2	L
			1	L + 256
			2	L + 256
			1	L

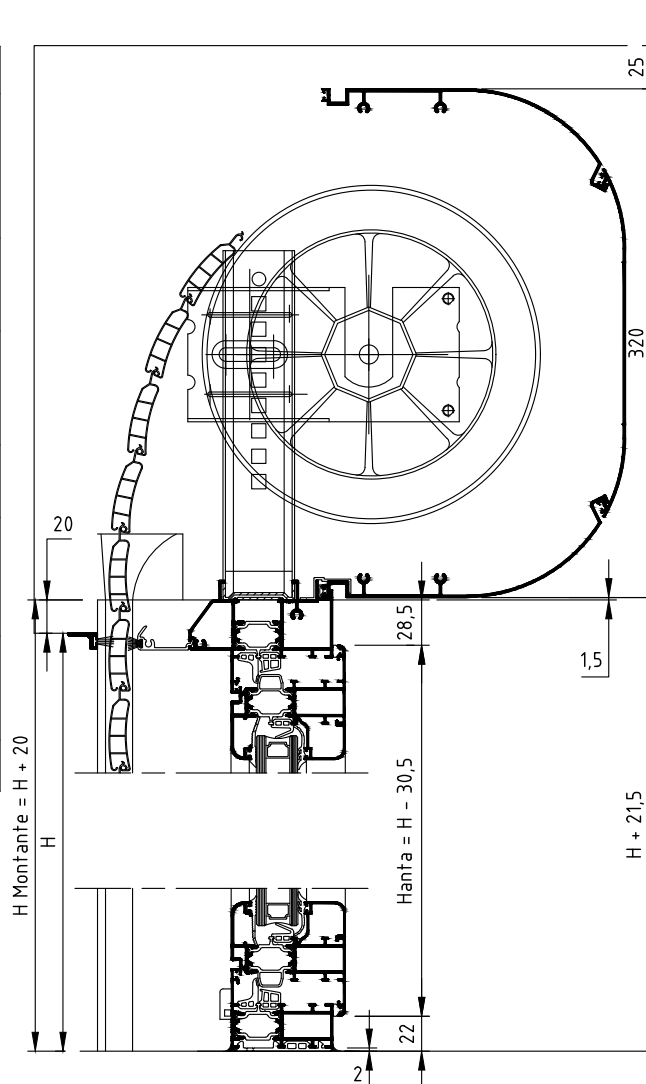

ACCESSORI
ACCESSORIES

ARTICOLO ITEM	DESCRIZIONE DESCRIPTION	N.
RA9943VV	Kit per monoblocco Kit for monoblock	1
RA2162TN	Tappi laterali per cassonetto ispezionabile (Cp) Lateral plug for inspectable rolling shutter box (Cp)	1
RA2160NN	Tappi chiudi feritoia tra montante e traverso (Cp) Plug for mullion and transom (Cp)	1
RA9942AA	Fissaggio cassonetto su traverso Fixing on the roller shutting box on the transom	3
42510055	Invito tapparella (coppia) Guide for rolling shutter (Cp)	1

GUARNIZIONI
WEATHERSTRIPS

ARTICOLO ITEM	DESCRIZIONE DESCRIPTION	N.
RG0126EN	Guarnizione di battuta Weatherstrip of rabbet	2H 1L
RG0168EN	Guarnizione isolamento termico telaio-muro Weatherstrip thermal insulation frame-wall	1L
Comm.le	Spazzolino 5 x 11mm Wool pile	3H 2L

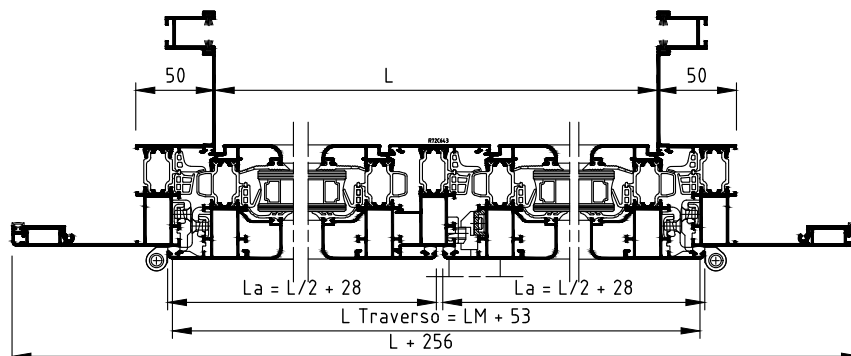

TUBOLARI ESTERNI RIDOTTI
REDUCED EXTERNAL TUBULARS

FINESTRA 2 ANTE CON ANTA RIBALTA
TWO-SASHES WINDOW-OVERLAP AND
AND TILT AND TURN

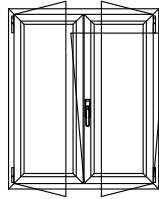

N.B.: - Le dimensioni di taglio e di lavorazione indicate nelle pagine seguenti sono state ottenute considerando le quote teoriche. Pertanto è necessario verificare sempre le dimensioni dei profilati prima di effettuare i tagli. Sapa declina ogni responsabilità per errori dovuti al mancato controllo da parte del costruttore.

N.B.: - The cutting and processing dimensions, indicated in the following pages, are obtained considering theoretical values. It is, therefore, always necessary to check the dimensions of the profiles before executing the cutting. Sapa declines any responsibility from errors caused from the missing dimensional check of the carpenter

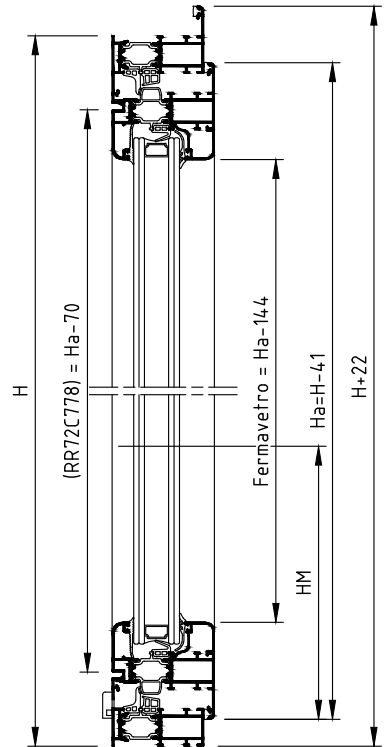
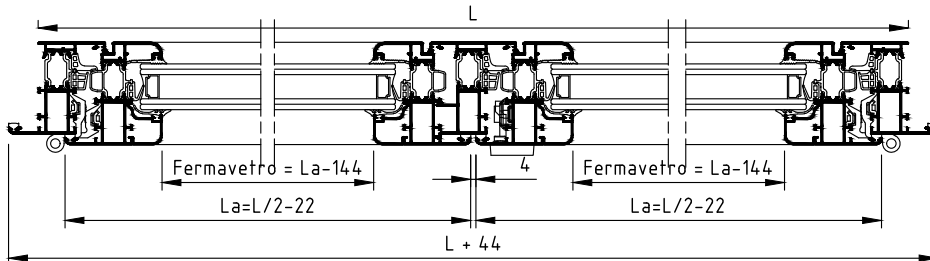

PROFILATI SECTIONS

Profilato tipo Type Section	N° Pz.	Taglio Cut	N° Pz.	Taglio Cut
RR72C775	1		1	
RR72C776	2		1	
RR72C777	4		4	
RR72C778	1			
R2900607	4		4	
R2900221	1	Verticale Inferiore Lower Vertical 	1	Verticale Superiore Upper Vertical
			1	Orizzontale Superiore Upper Horizontal

DIMENSIONI VETRI
GLASSES SIZE

N. 2 PEZZI	N.B.: Spessore vetro considerato 34 mm (4/4+18+4/4) Gioco perimetrale tra profilato e vetro 5 mm For glass with 34mm thickness Space between glass and profile 5 mm
Ha - 110	
La - 110	

(*) = Valido per ante con La da 650 a 1701 mm (braccio lungo = RA5721VV) This for wings with L from 650 to 1701 mm (long arm = RA5721VV)

ACCESSORI ACCESSORIES

Articolo Item	Descrizione Description	N	Articolo Item	Descrizione Description	N	Articolo Item	Descrizione Description	N
RA5730VV	Kit cerniere e braccio per anta affiancata Hinges and arms kit for side sash	1	RA5441AA	Squadretta per giunzione d'angolo Corner joint	12	RA5765NN	Tappo rotondo copriforo diametro 12 mm Circular coverhole plug dia. mm 12	5
RA5732VV	Catenaccio a leva bid.le per anta affiancata Two way latch for passive sash	1	RA2127TN	Coppia tappi per riporto centrale RR72C643 Pair of plugs for central rabbet on profile RR72C643	1	RA0228EN	Angolo stampato per precamera Moulded corner for central weatherstrip	4
RA3104BA	Squadretta Fuji allineamento aletta Fuji alignment corner joint on fin.	4	RA2834AA	Supporto vetro Glass support	4	RA0202BA	Angolo stampato per fermavetro arrotondato Moulded corner for snap-on rounded glass beading	8
RA2930AA	Squadretta allineamento aletta * Alignment corner joint on fin	6	RA5532NN	Cappetta scarico acqua con valvola Water drain cover with valve	2			
RA3105BA	Squadretta Fuji all.mento aletta prof. compl. Fuji alignment corner joint for coplanar profiles	8	RA5756ZA	Basetta unificata per regolo mobile Unified plate for adjustable block	5			
RA2922AA	Squadretta a cianfr / spinare su prof. est. anta Clamping/pin corner joint for external tubular of sash	12	RA5757ZA	Regolo mobile da 15 mm Adjustable block mm 15	5			

(*) = In corrispondenza del cardine inferiore e superiore AR e delle cerniere affiancate, non sarà possibile inserire le squadrette di allineamento RA2930AA
In correspondence of the bottom and upper hinges of the tilt and turn and the hinges for passive sash, is not possible use the alignment corner joint RA2930AA

GUARNIZIONI WEATHERSTRIPS

Articolo Item	Descrizione Description	N	Articolo Item	Descrizione Description	N	Articolo Item	Descrizione Description	N
RG0126EN	Guarnizione di battuta Weatherstrip of rabbet	6H 3L	RG0143EN	Guarnizione aggiuntiva di precamera Additional central Weatherstrip	3H 2L	RG0135EN	Guarnizione di precamera Central weatherstrip	3H 2L
RG0124EN	Guarnizione interna tenuta vetro 3 mm Weatherstrip on glazing bead shim mm 3	4H 2L	RG0152EN	Guarnizione esterna appoggio vetri 3 mm Weatherstrip on glass support mm 3	4H 2L	RG0148EN	Guarnizione sotto vetro Weatherstrip under glass	4H 2L

TUBOLARI ESTERNI RIDOTTI
REDUCED EXTERNAL TUBULARS

FINESTRA 2 ANTE CON ANTA RIBALTA
MAGGIORATA
TWO-SASHES WINDOW-OVERLAP AND
AND TILT AND TURN REINFORCED

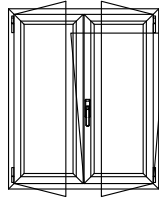

N.B.: - Le dimensioni di taglio e di lavorazione indicate nelle pagine seguenti sono state ottenute considerando le quote teoriche. Pertanto è necessario verificare sempre le dimensioni dei profilati prima di effettuare i tagli. Sapa declina ogni responsabilità per errori dovuti al mancato controllo da parte del costruttore.

N.B.: - The cutting and processing dimensions, indicated in the following pages, are obtained considering theoretical values. It is, therefore, always necessary to check the dimensions of the profiles before executing the cutting. Sapa declines any responsibility from errors caused from the missing dimensional check of the carpenter

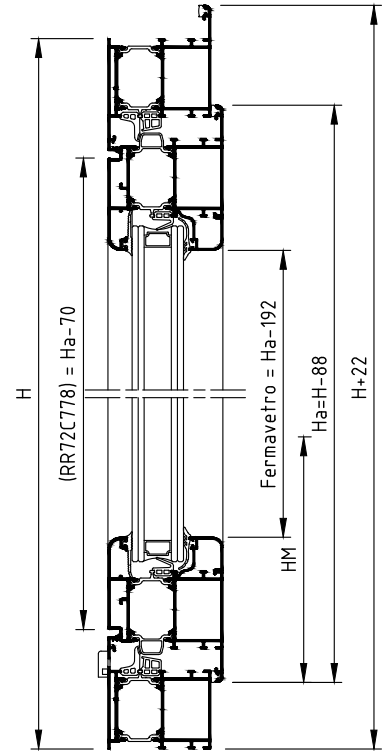
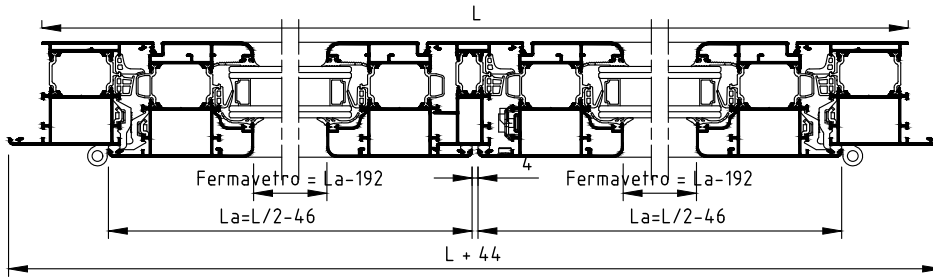

PROFILATI SECTIONS

Profilato tipo Type Section	N° Pz.	Taglio Cut	N° Pz.	Taglio Cut		
RR72C784			1	L		
RR72C782	2	H + 22	1	L + 44		
RR72C781	4	Ha = H - 88	4	La = L / 2 - 46		
RR72C778	1	Ha - 70				
R2900607	4	Ha - 192	4	La - 192		
R2900221	1	Verticale Inferiore Lower Vertical Hm - 97	1	Verticale Superiore Upper Vertical Ha - Hm - 176	1	Orizzontale Superiore Upper Horizontal La - 532 (x)

DIMENSIONI VETRI
GLASSES SIZE

N. 2 PEZZI		N.B.: Spessore vetro considerato 34 mm (4/4+18+4/4) Gioco perimetrale tra profilato e vetro 5 mm For glass with 34mm thickness Space between glass and profile 5 mm
Ha - 110		
La - 110		

(*) = Valido per ante con La da 650 a 1701 mm (braccio lungo = RA5721VV) This for wings with L from 650 to 1701 mm (long arm = RA5721VV)

ACCESSORI ACCESSORIES

Articolo Item	Descrizione Description	N	Articolo Item	Descrizione Description	N	Articolo Item	Descrizione Description	N
RA3104BA	Squadretta Fuji allineamento aletta Fuji alignment corner joint on fin.	4	RA2127TN	Coppia tappi per riporto centrale RR72C643 Pair of plugs for central rabbet on profile RR72C643	1	RA5765NN	Tappo rotondo copriforo diametro 12 mm Circular coverhole plug dia. mm 12	5
RA2930AA	Squadretta allineamento aletta * Alignment corner joint on fin	6	RA2834AA	Supporto vetro Glass support	4	RA0228EN	Angolo stampato per precamera Moulded corner for central weatherstrip	4
RA3105BA	Squadretta Fuji all.mento aletta prof. compl. Fuji alignment corner joint for coplanar profiles	8	RA5532NN	Cappetta scarico acqua con valvola Water drain cover with valve	2	RA0202BA	Angolo stampato per fermavetro arrotondato Moulded corner for snap-on rounded glass beading	8
RA2923AA	Squadretta cianfr/spinare x tub.est.maggiorati Crimping/pin corner joint for reinforced ext. tubular	12	RA5756ZA	Basetta unificata per regolo mobile Unified plate for adjustable block	5			
RA5429AA	Squadretta cianfr/spinare x tub.int.maggiorati Crimping/pin corner joint for reinforced int. tubular	12	RA5757ZA	Regolo mobile da 15 mm Adjustable block mm 15	5			

(*) = In corrispondenza del cardine inferiore e superiore AR e delle cerniere affiancate, non sarà possibile inserire le squadrette di allineamento RA2930AA
In corrispondence of the bottom and upper hinges of the tilt and turn and the hinges for passive sash, is not possible use the alignment corner joint RA2930AA

GUARNIZIONI WEATHERSTRIPS

Articolo Item	Descrizione Description	N	Articolo Item	Descrizione Description	N	Articolo Item	Descrizione Description	N
RG0126EN	Guarnizione di battuta Weatherstrip of rabbet	6H 3L	RG0143EN	Guarnizione aggiuntiva di precamera Additional central Weatherstrip	3H 2L	RG0135EN	Guarnizione di precamera Central weatherstrip	3H 2L
RG0124EN	Guarnizione interna tenuta vetro 3 mm Weatherstrip on glazing bead shim mm 3	4H 2L	RG0152EN	Guarnizione esterna appoggio vetri 3 mm Weatherstrip on glass support mm 3	4H 2L	RG0148EN	Guarnizione sotto vetro Weatherstrip under glass	4H 2L

ANTA SCOMPARSA RIDOTTA - DISTINTE DI TAGLIO
REDUCED HIDDEN SASH - CUT LISTS

FINESTRA 1 ANTA
ONE-SASH WINDOW

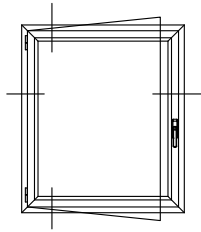

N.B. - Le dimensioni di taglio e di lavorazione indicate nelle pagine seguenti sono state ottenute considerando le quote teoriche.
Pertanto è necessario verificare sempre le dimensioni dei profilati prima di effettuare i tagli.
Sapa declina ogni responsabilità per errori dovuti al mancato controllo da parte del costruttore.

N.B. - The cutting and processing dimensions, indicated in the following pages, are obtained considering theoretical values.
It is, therefore, always necessary to check the dimensions of the profiles before executing the cutting.
Sapa declines any responsibility from errors caused from the missing dimensional check of the carpenter

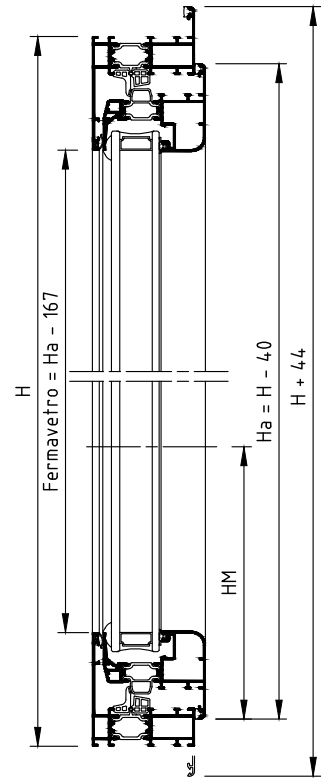
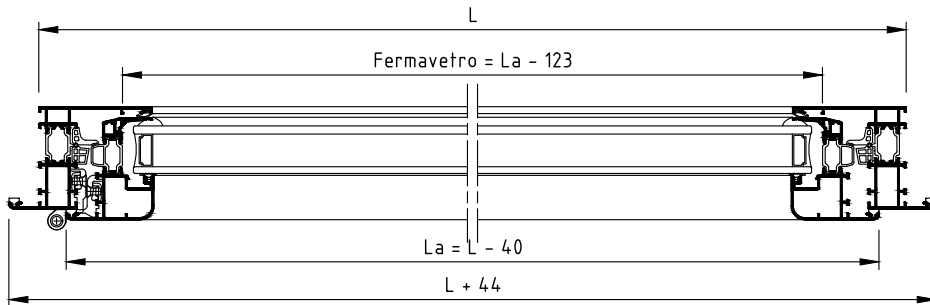

PROFILATI SECTIONS

Profilato tipo Type Section	N° Pz.	Taglio Cut	N° Pz.	Taglio Cut
	2		1	
			1	
	2		2	
	2		2	
	1		1	

DIMENSIONI VETRO GLASS SIZE

N. 1 PEZZO	N.B.: Spessore vetro considerato 35 mm Gioco perimetrale tra profilato e vetro 8 mm For glass with 35 mm thickness Space between glass and profile 8 mm
Ha - 100	
La - 100	

ACCESSORI ACCESSORIES

Articolo Item	Descrizione Description	N	Articolo Item	Descrizione Description	N
2019 (Mont.)	Squadretta Fuji allineamento aletta Fuji alignment corner joint on fin.	4	RA5532NN	Cappetta scarico acqua con valvola Water drainage cover cup with valve	2
RA2930AA	Squadretta allineamento aletta Alignment corner joint on fin	6	RA5756ZA	Basetta unificata per regolo mobile Unified plate for adjustable block	5
RA2911AA	Squadretta tubolari esterni telaio External corner joint on frame	4	RA5757ZA	Regolo mobile da 15 mm Adjustable block mm 15	5
RA5441AA	Squadretta per giunzione d'angolo Corner joint	8	RA5765NN	Tappo rotondo copriforo diametro 12 mm Circular coverhole plug dia. mm 12	5
RA5662AA	Squadretta a cianfrinare su prof. est. anta External corner joint to be crimped	4	RA0228TN	Angolo stampato per precamera Moulded corner for central weatherstrip	4
RA2804AA	Supporto vetro Glass support	2			

GUARNIZIONI WEATHERSTRIPS

Articolo Item	Descrizione Description	N	Articolo Item	Descrizione Description	N
RG0126EN	Guarnizione di battuta Gasket of rabbet	4H 3L	RG0149EN	Guarnizione esterna appoggio vetri 4 mm Gasket on glass support mm 4	2H 2L
RG0139RN	Guarnizione interna tenuta vetro 1,5mm Gasket on glazing bead shim mm 4-6	2H 2L	RG0135EN	Guarnizione di precamera Central gasket	2H 2L
RG0143EN	Guarnizione aggiuntiva di precamera Additional central gasket	2H 2L	RG0169EN	Guarnizione battuta telaio * Rabbet gasket on frame	2H 2L

* Interrompere le guarnizioni nella parte superiore orizzontale in 2 tratti da 20 cm (preferibilmente agli angoli)
The gasket must be cut twice on the horizontal upper part. The cutting length is 20 cm.

LAVORAZIONI

TOOLINGS

SQUADRETTA D'ANGOLO
CORNER JOINT

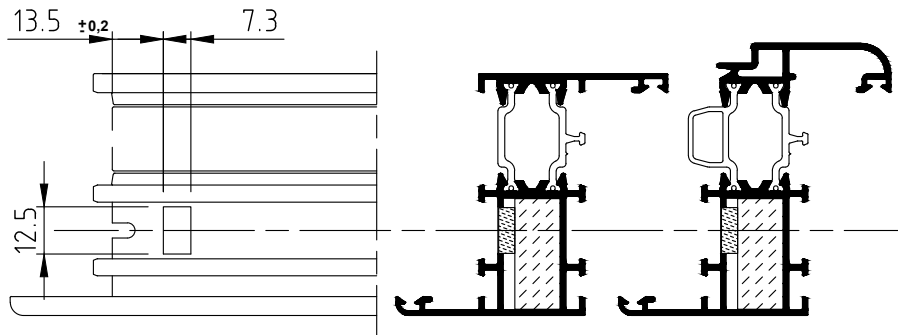

ART. : RA5441AA



Attrezzatura: PUNZONATRICE
Tooling: PUNCHING MACHINE

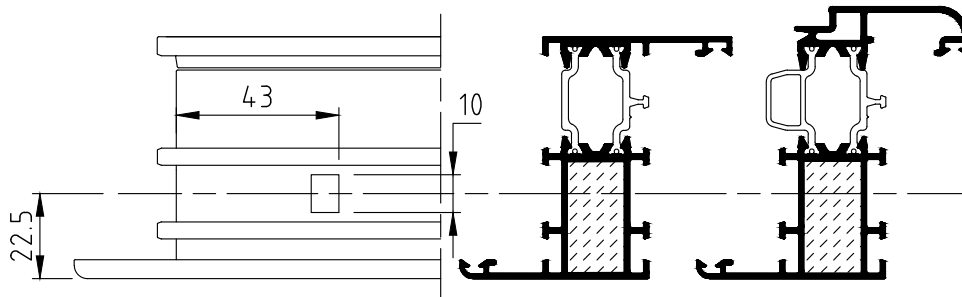

ART. : 5034 (Monticelli)



Attrezzatura: CIANFRINATRICE MANUALE
Tooling: MANUAL CRIMPING TOOL

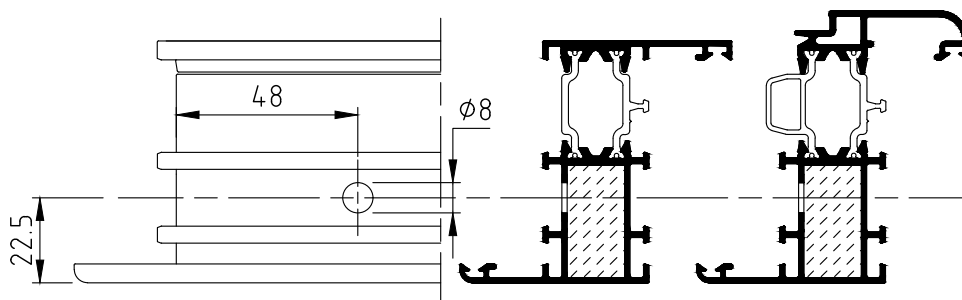

ART. : 5034 (Monticelli)



ART. : RA9945VV



Attrezzatura: TRAPANO
Tooling: DRILL

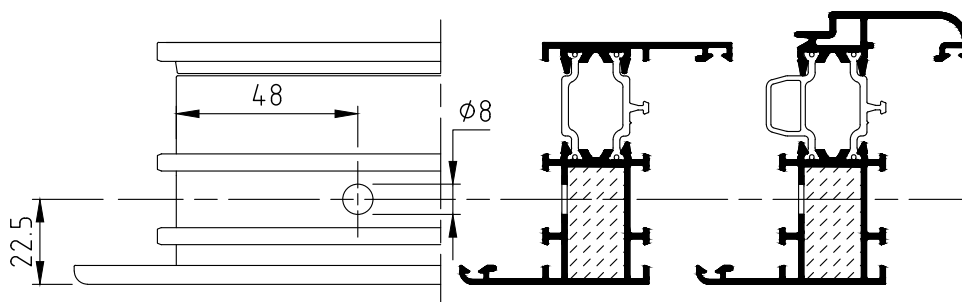

ART. : 5034 (Monticelli)



ART. : RA9945VV



Attrezzatura: TRAPANO
Tooling: DRILL

SQUADRETTA D'ANGOLO
CORNER JOINT

ART. : RA5429AA

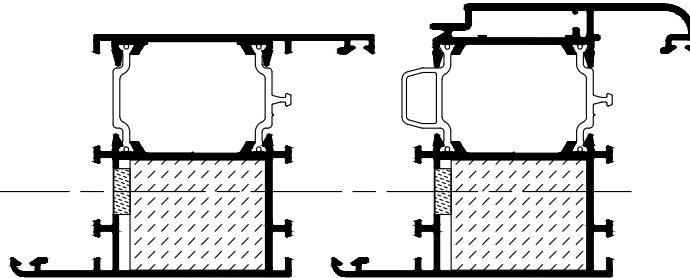
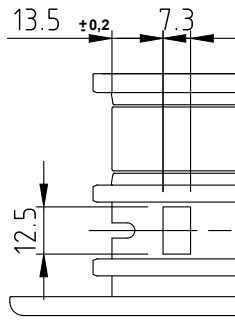

Attrezzatura: PUNZONATRICE
Tooling: PUNCHING MACHINE

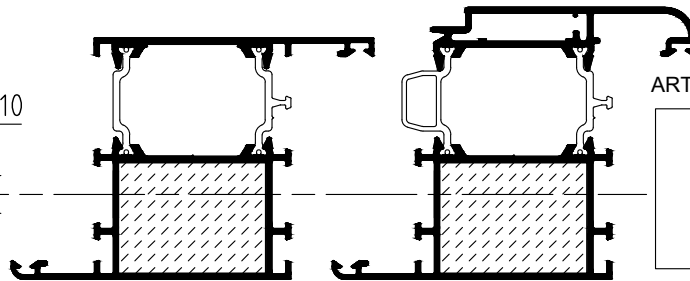
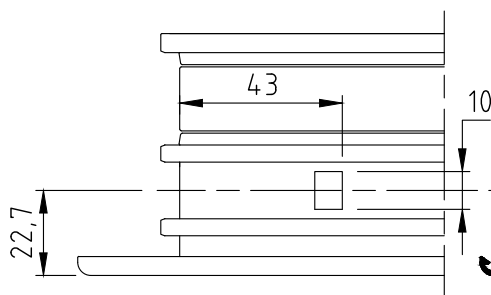

ART. : 5043 (Monticelli)



Attrezzatura: CIANFRINATRICE MANUALE
Tooling: MANUAL CRIMPING TOOL

LAVORAZIONE ESTERNA
EXTERNAL TOOLING

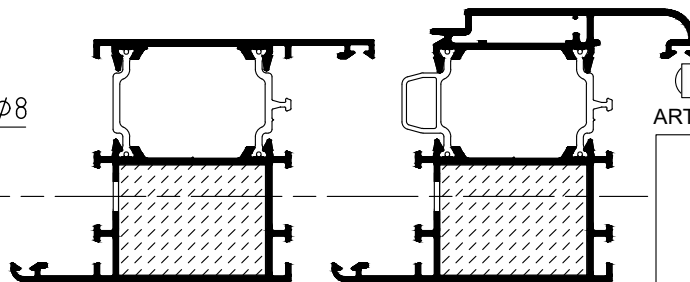
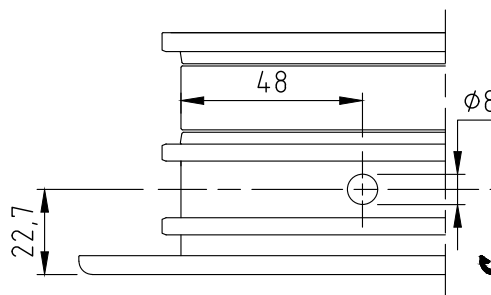

RA9945VV

ART. : 5043 (Monticelli)

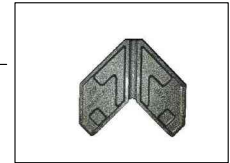

Attrezzatura: TRAPANO
Tooling: DRILL

LAVORAZIONE ESTERNA
EXTERNAL TOOLING

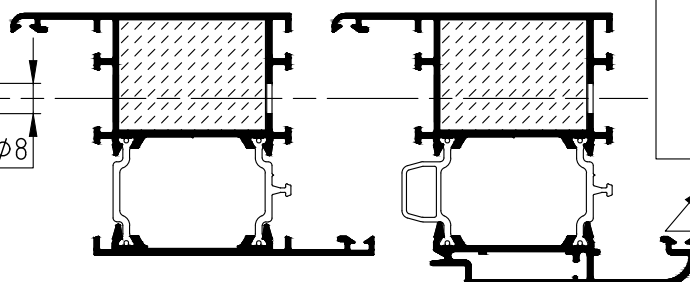
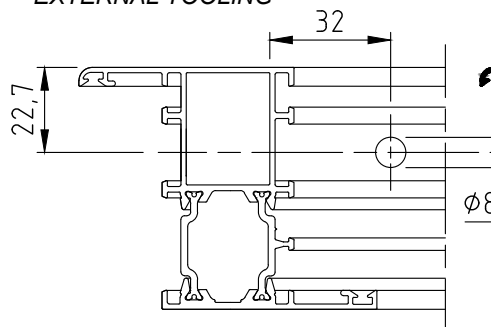

ART. : 5043 (Monticelli)

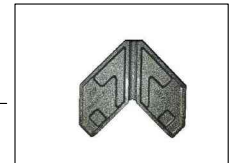

RA9945VV

Attrezzatura: TRAPANO
Tooling: DRILL

SQUADRETTA D'ANGOLO
CORNER JOINT

LAVORAZIONE ESTERNA
EXTERNAL TOOLING

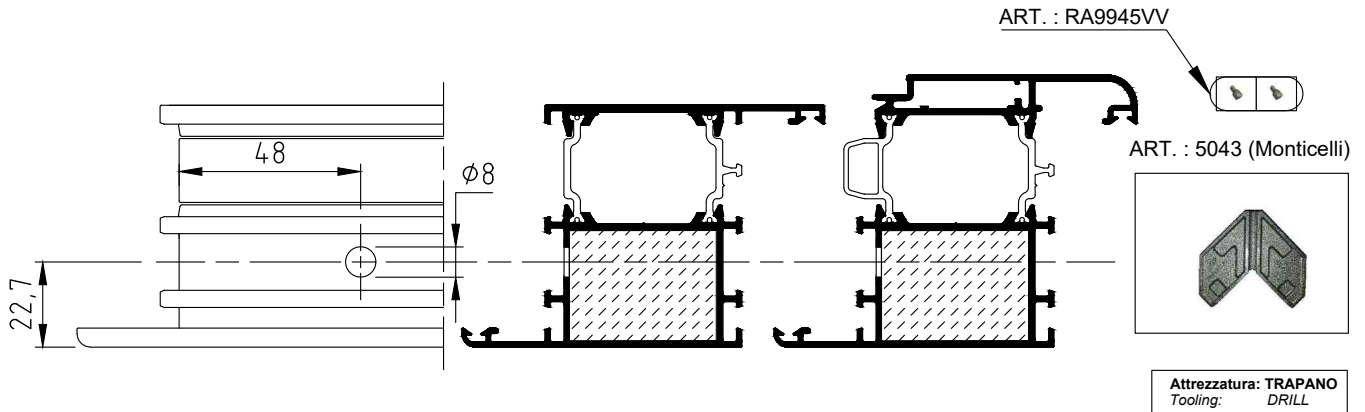

LAVORAZIONE ESTERNA
EXTERNAL TOOLING

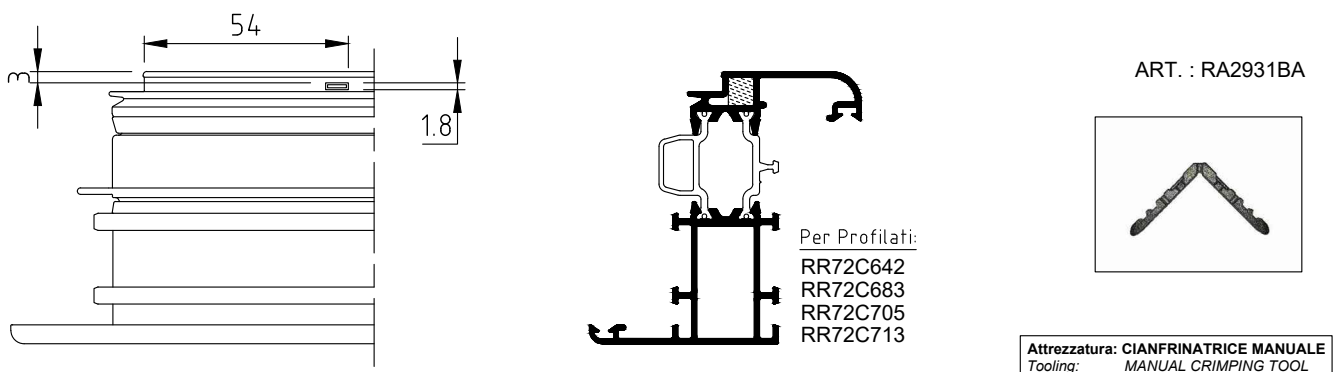
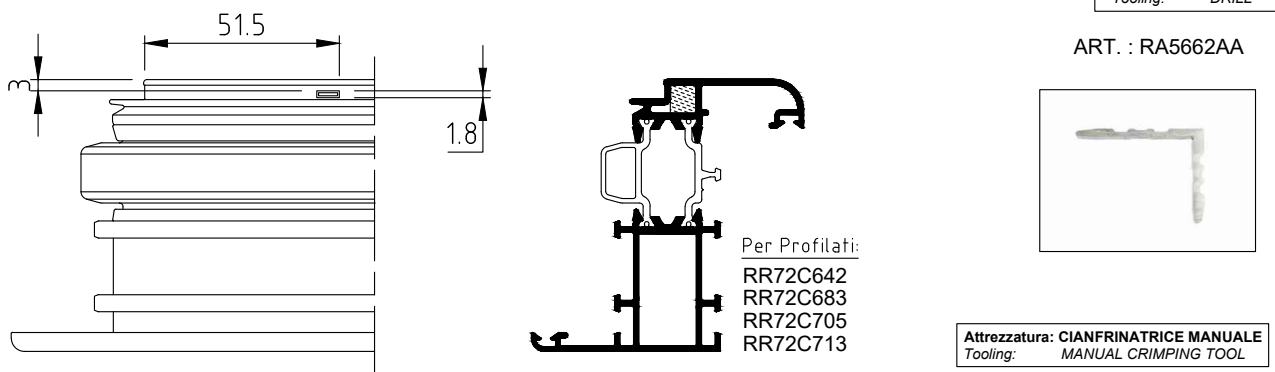
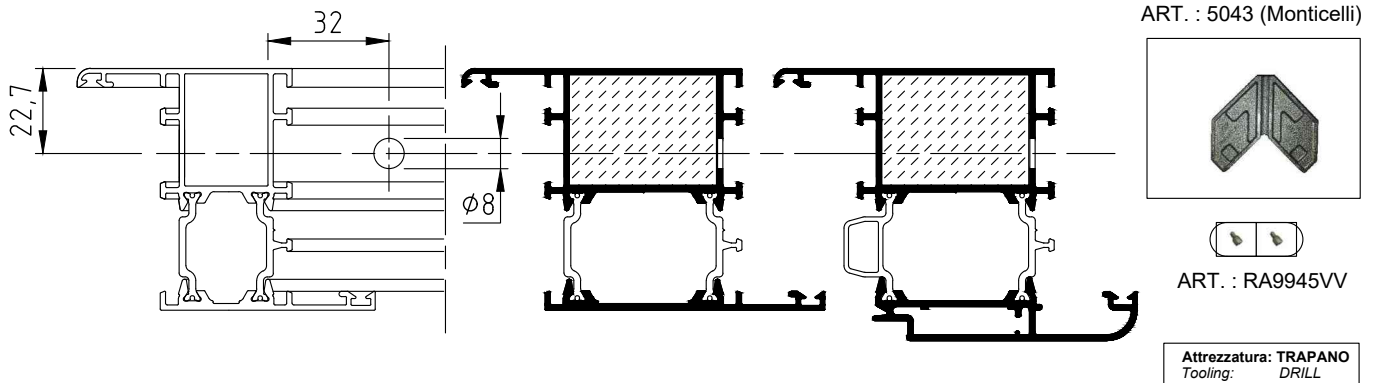

SQUADRETTA D'ANGOLO
CORNER JOINT

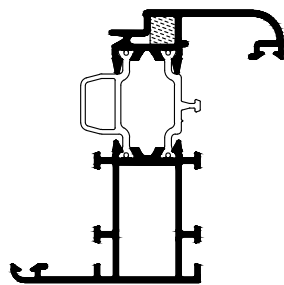
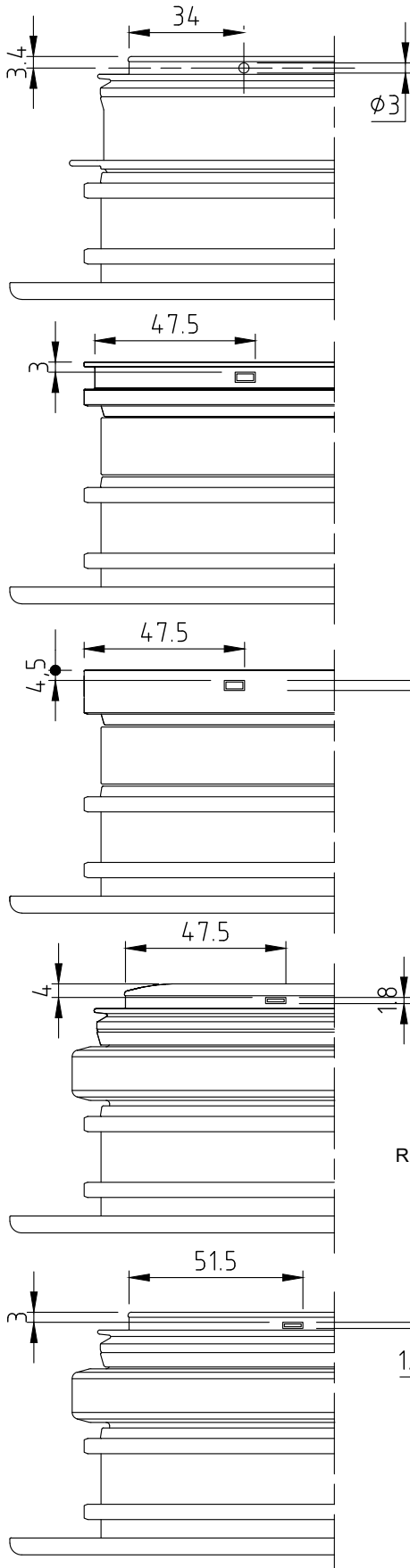

Per Profilati:
RR72C642
RR72C683
RR72C705
RR72C713

RA2931BA

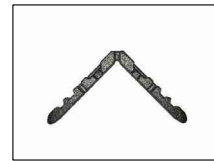

Spina RA2929KA



Attrezzatura: TRAPANO
Tooling: DRILL

RR72C682

RR72C681

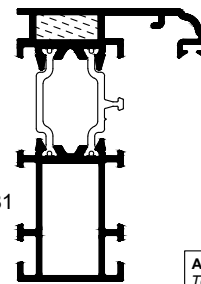
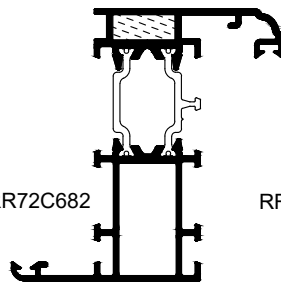

ART. : RA2921AA



Attrezzatura: CIANFRINATRICE MANUALE
Tooling: MANUAL CRIMPING TOOL

RR72C745
RR72C747

RR72C744
RR72C746

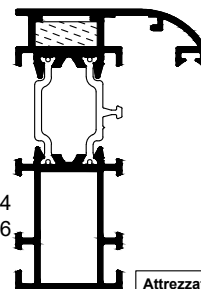
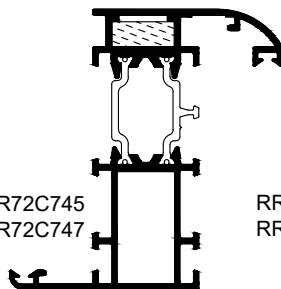

ART. : RA2921AA



Attrezzatura: CIANFRINATRICE MANUALE
Tooling: MANUAL CRIMPING TOOL

RR72C675

RR72C700

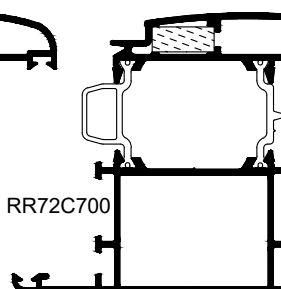
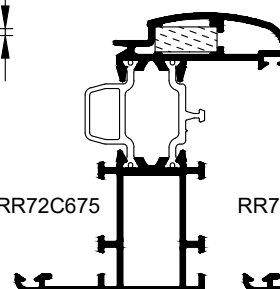

ART. : RA2921AA



Attrezzatura: CIANFRINATRICE MANUALE
Tooling: MANUAL CRIMPING TOOL

Per Profilati:

RR72C653
RR72C673
RR72C698
RR72C703
RR72C706
RR72C709

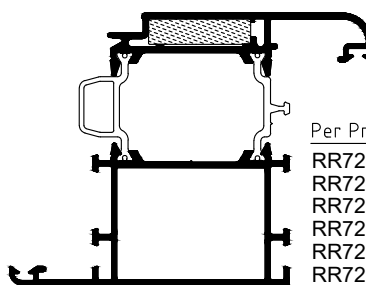

ART. : RA5624AA

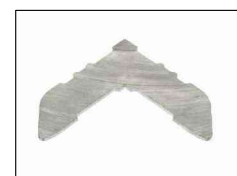

Attrezzatura: CIANFRINATRICE MANUALE
Tooling: MANUAL CRIMPING TOOL

SQUADRETTA D'ANGOLO
CORNER JOINT

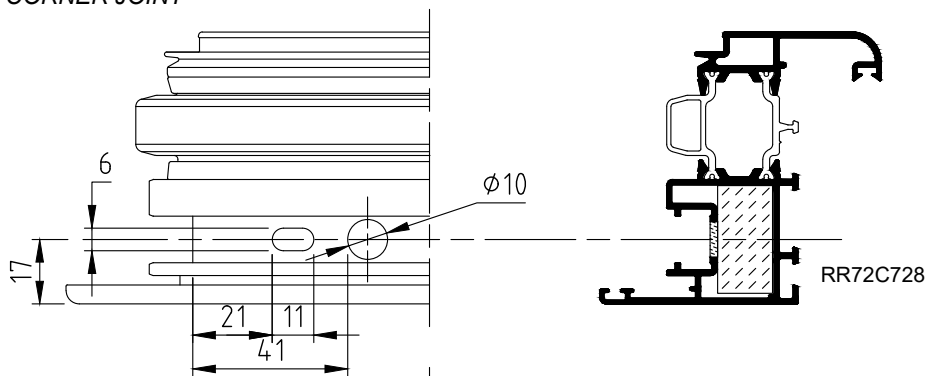

RA2935BA



Attrezzatura: PUNZONATRICE RM.0006.R5
Tooling: PUNCHING MACHINE RM.0006.R5

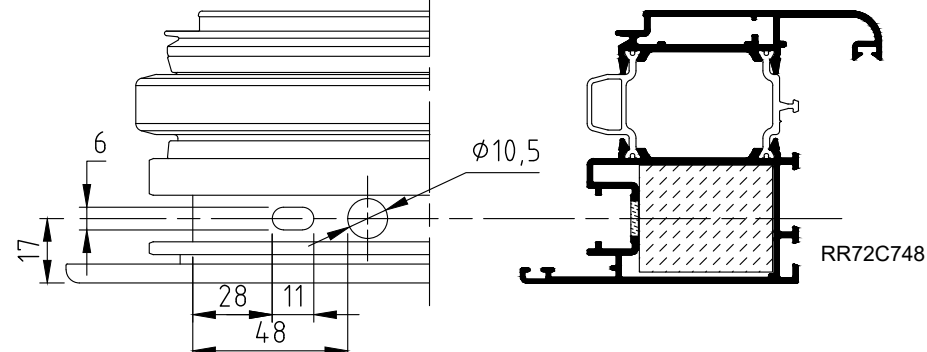

ART. : 0496 (Monticelli)



Attrezzatura: PUNZONATRICE RM.0006.R5
Tooling: PUNCHING MACHINE RM.0006.R5

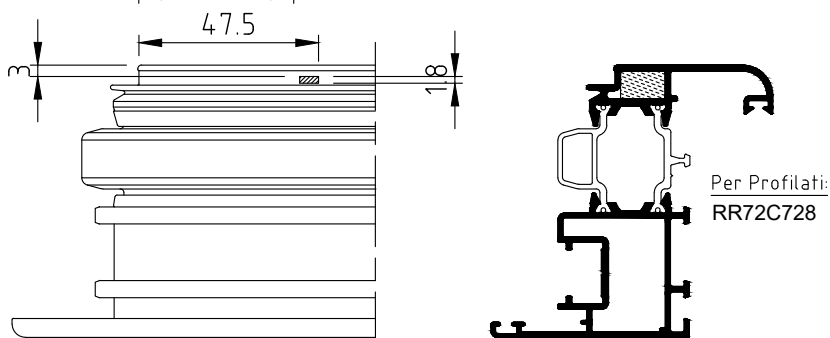

ART. : RA2910AA

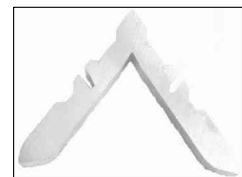

Attrezzatura: CIANFRINATRICE MANUALE
Tooling: MANUAL CRIMPING TOOL

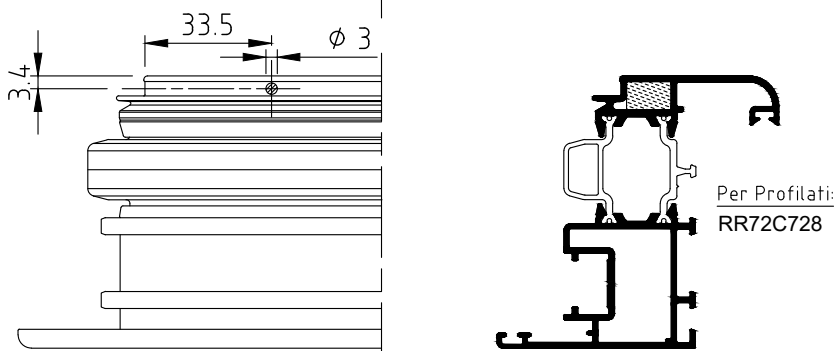

ART. : RA2910AA



Spina RA2929KA



Attrezzatura: TRAPANO
Tooling: DRILL

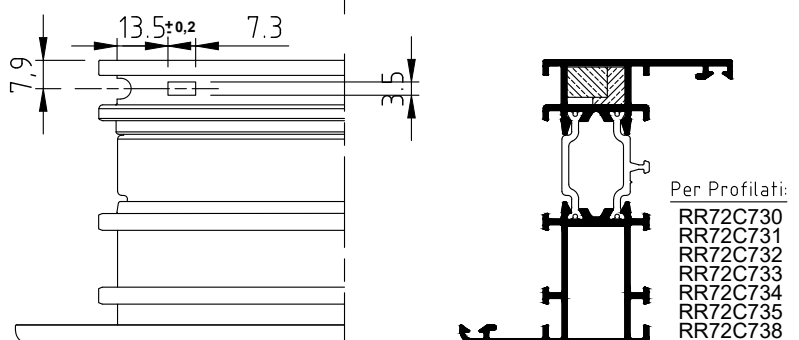

ART. : RA2911AA



Attrezzatura: PUNZONATRICE RM.0005.R5
Tooling: PUNCHING MACHINE RM.0005.R5

SQUADRETTA D'ANGOLO
CORNER JOINT

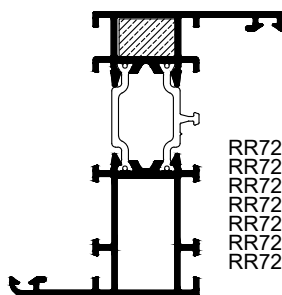
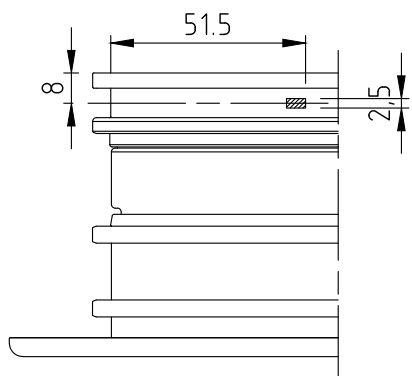

RR72C730
RR72C731
RR72C732
RR72C733
RR72C734
RR72C735
RR72C738

ART. : RA2912AA



Attrezzatura: CIANFRINATRICE MANUALE
Tooling: MANUAL CRIMPING TOOL

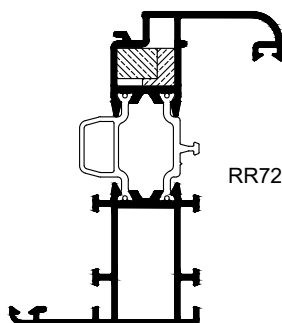
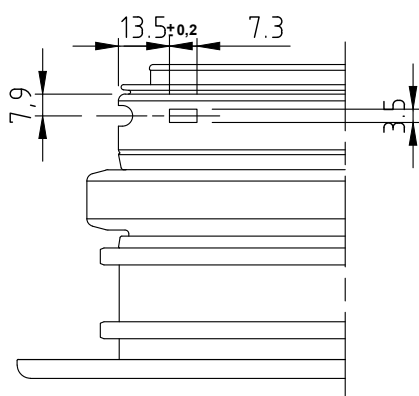

RR72C736

ART. : RA2911AA



Attrezzatura: PUNZONATRICE RM.0005.R5
Tooling: PUNCHING MACHINE RM.0005.R5

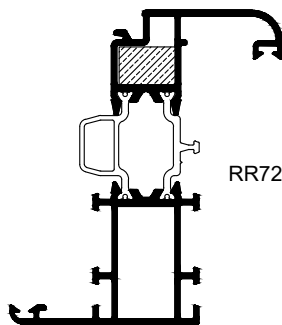
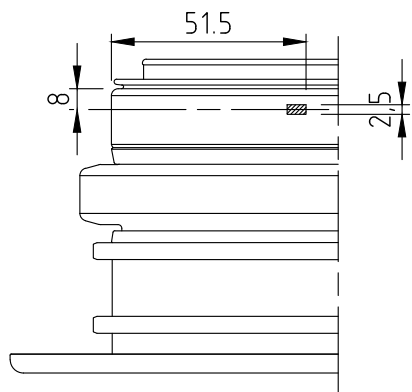

RR72C736

ART. : RA2912AA



Attrezzatura: CIANFRINATRICE MANUALE
Tooling: MANUAL CRIMPING TOOL

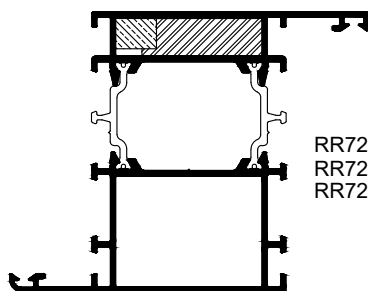
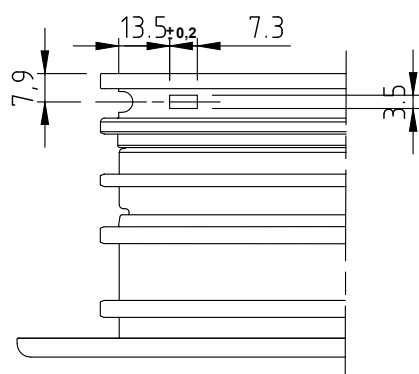

RR72C749
RR72C750
RR72C751

ART. : RA2914AA



Attrezzatura: PUNZONATRICE RM.0005.R5
Tooling: PUNCHING MACHINE RM.0005.R5

SQUADRETTA D'ANGOLO
CORNER JOINT

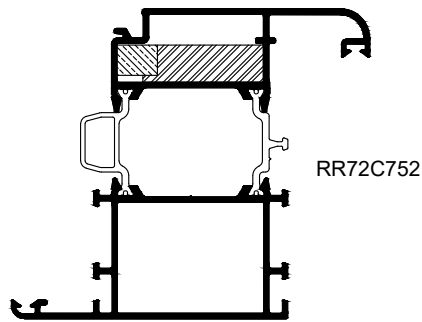
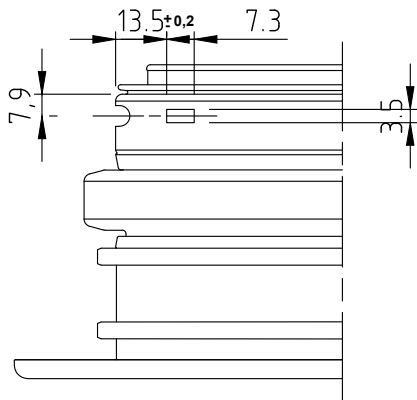

ART. : RA2914AA



Attrezzatura: PUNZONATRICE RM.0005.R5
Tooling: PUNCHING MACHINE RM.0005.R5

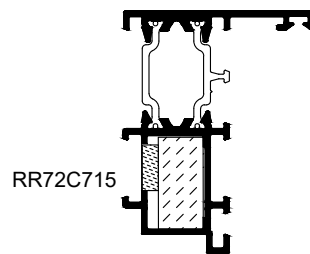
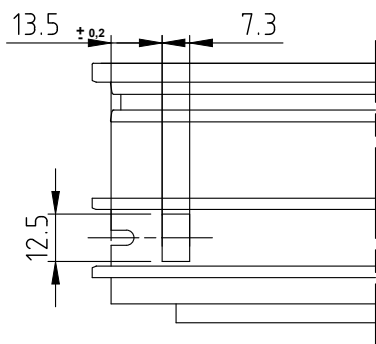

RA2915AA



Attrezzatura: PUNZONATRICE
Tooling: PUNCHING MACHINE

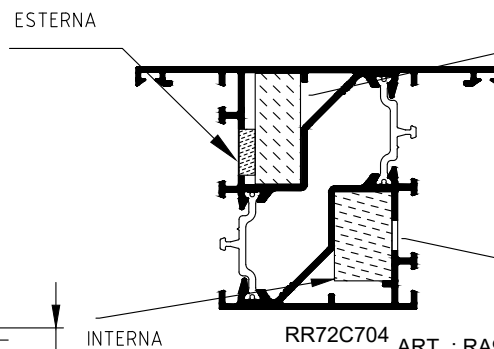
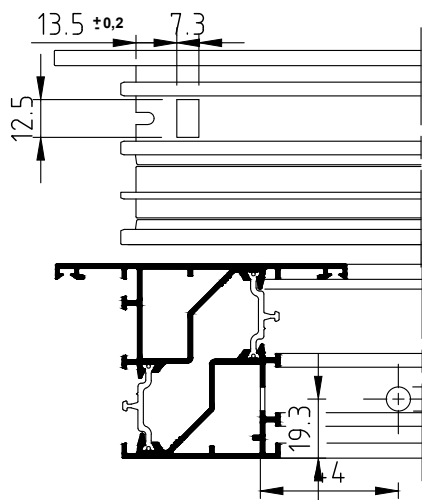

ART. : RA5441AA



Attrezzatura: PUNZONATRICE
Tooling: PUNCHING MACHINE

ART. : RA2932BA

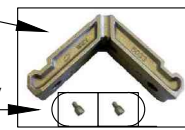

ART. : RA9945VV

Attrezzatura: TRAPANO
Tooling: DRILL

ASPORTAZIONE DENTINI PER INSERIMENTO ASTA
TOOTH REMOVAL FOR ROD NOTCH

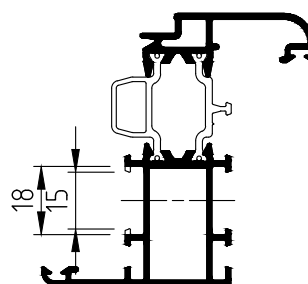
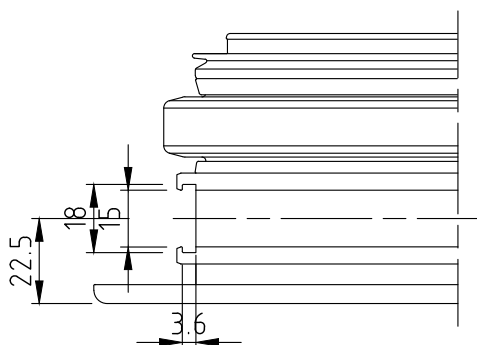

R2900221

Attrezzatura: PUNZONATRICE
Tooling: PUNCHING MACHINE

TUBOLARI ESTERNI RIDOTTI
REDUCED EXTERNAL TUBULARS

SQUADRETTA D'ANGOLO
CORNER JOINT

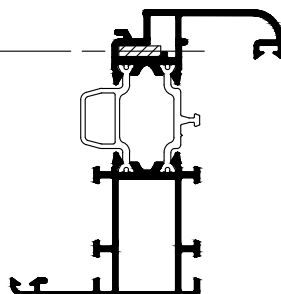
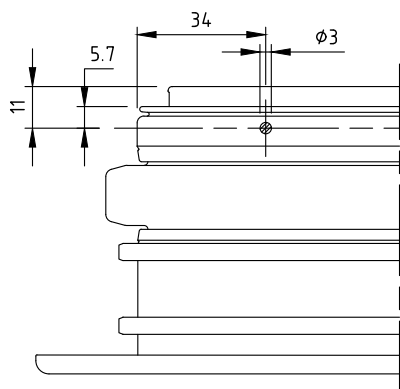

RR72C777

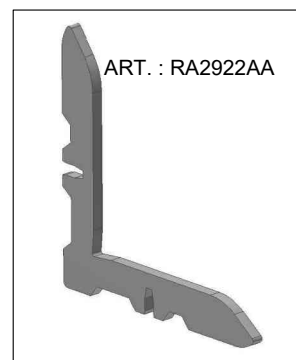

ART. : RA2922AA

Attrezzatura: DIMA DI FORATURA ZEX18326
Tooling: DRILLING JIG ZEX18326

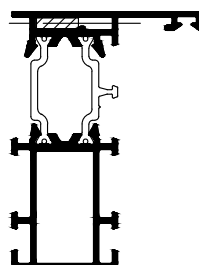
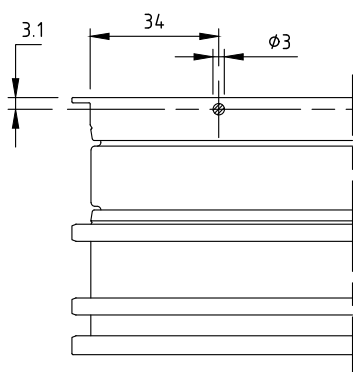

RR72C775
RR72C776

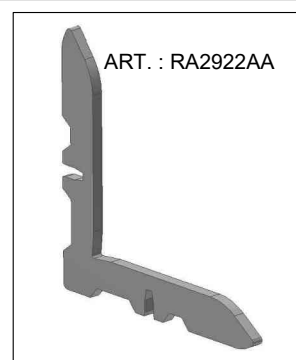

ART. : RA2922AA

Attrezzatura: DIMA DI FORATURA ZEX18326
Tooling: DRILLING JIG ZEX18326

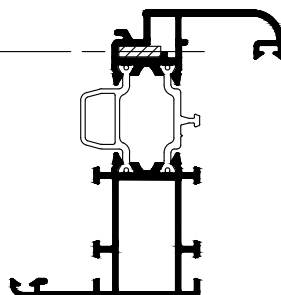
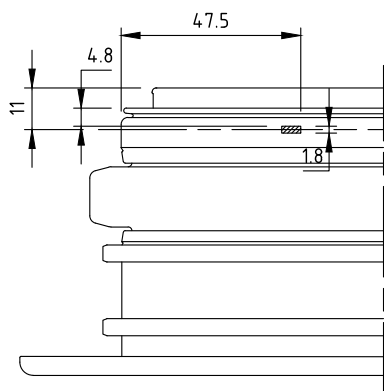

RR72C777

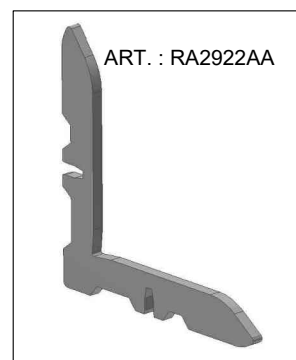

ART. : RA2922AA

Attrezzatura: CIANFRINATRICE MANUALE
Tooling: MANUAL CRIMPING TOOL

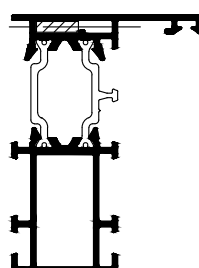
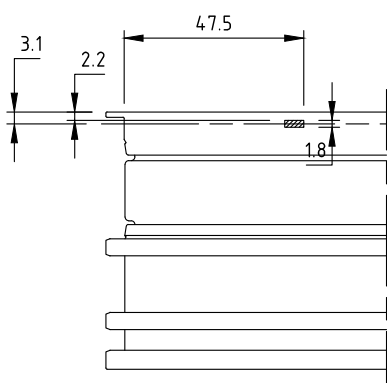

RR72C775
RR72C776

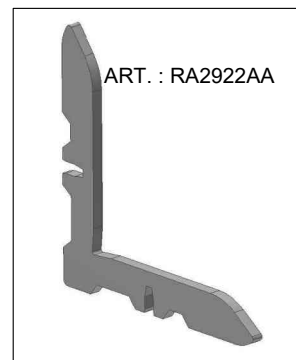

ART. : RA2922AA

TUBOLARI ESTERNI RIDOTTI
REDUCED EXTERNAL TUBOLARS

SQUADRETTA D'ANGOLO
CORNER JOINT

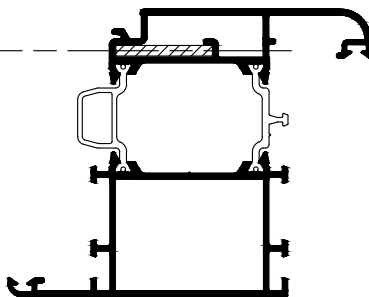
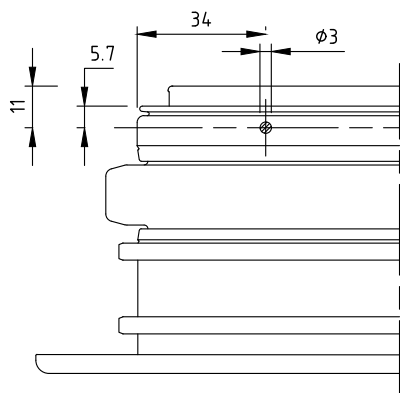

RR72C781

ART. : RA2923AA

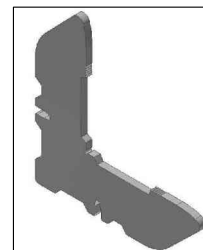

Attrezzatura: DIMA DI FORATURA ZEX18326
Tooling: DRILLING JIG ZEX18326

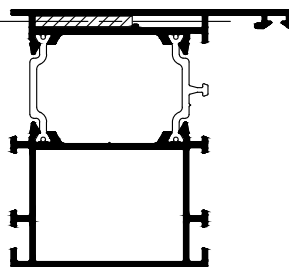
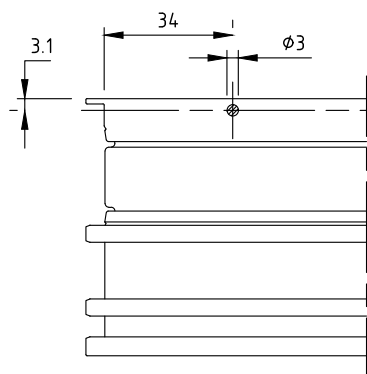

RR72C782
RR72C784

ART. : RA2923AA

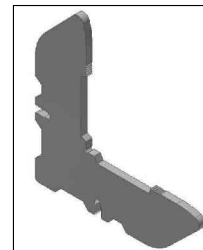

Attrezzatura: DIMA DI FORATURA ZEX18326
Tooling: DRILLING JIG ZEX18326

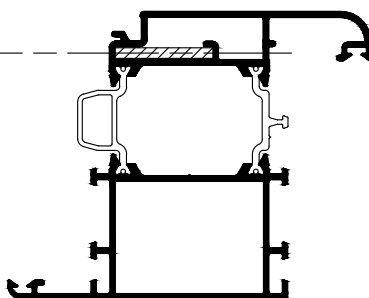
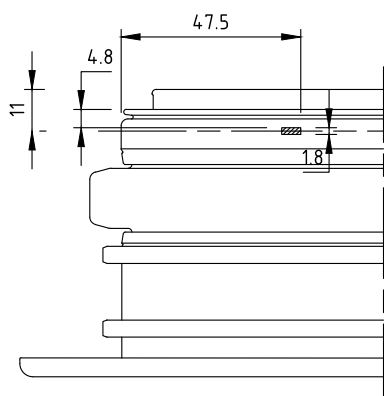

RR72C781

ART. : RA2923AA

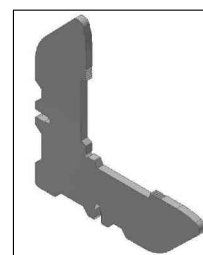

Attrezzatura: CIANFRINATRICE MANUALE
Tooling: MANUAL CRIMPING TOOL

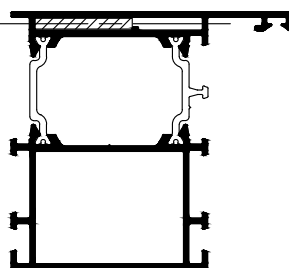
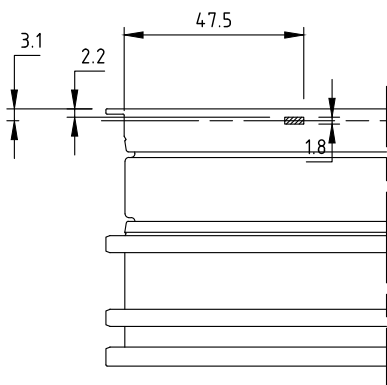

RR72C782
RR72C784

ART. : RA2923AA

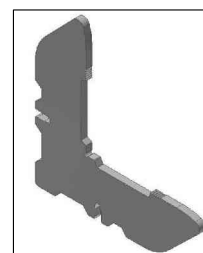

Attrezzatura: CIANFRINATRICE MANUALE
Tooling: MANUAL CRIMPING TOOL

LAVORAZIONI
TOOLINGS

SQUADRETTA D'ANGOLO
CORNER JOINT

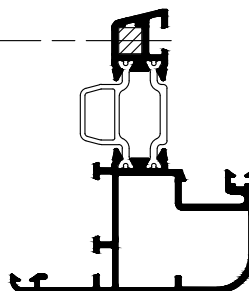
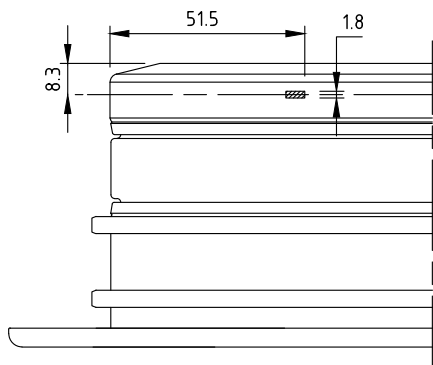

RR72C771

ART. : RA5662AA



Attrezzatura: CIANFRINATRICE MANUALE
Tooling: MANUAL CRIMPING TOOL

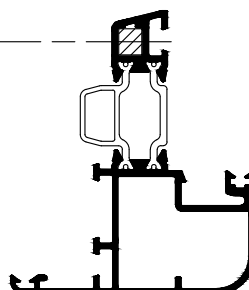
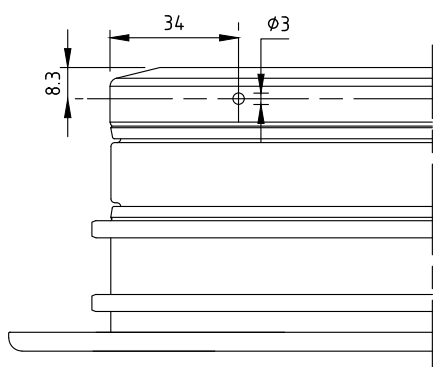

RR72C771

ART. : RA2931BA



Attrezzatura: TRAPANO
Tooling: DRILL

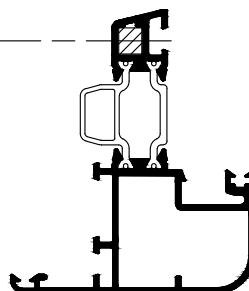
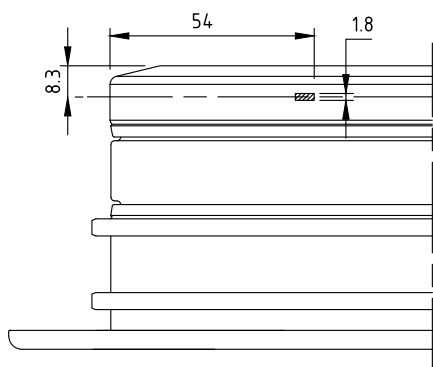

RR72C771

ART. : RA2931BA



Attrezzatura: CIANFRINATRICE MANUALE
Tooling: MANUAL CRIMPING TOOL

APPLICAZIONE SQUADRETTE DI ALLINEAMENTO
ALIGNMENT CORNER JOINTS APPLICATION

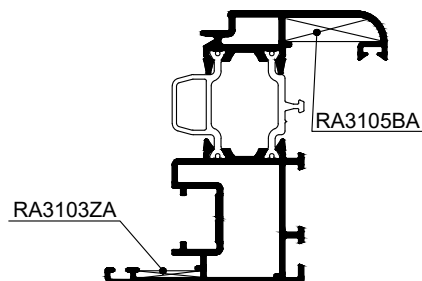
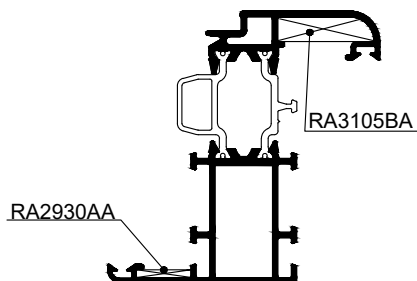
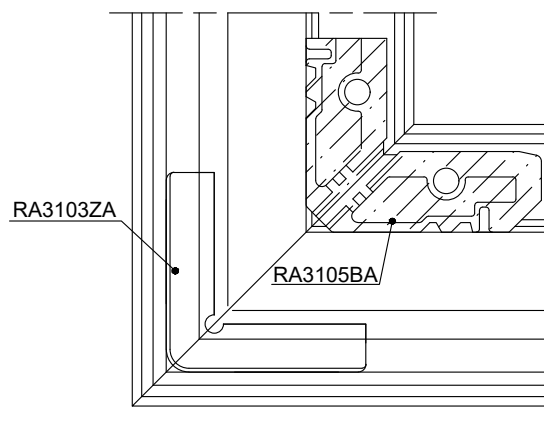
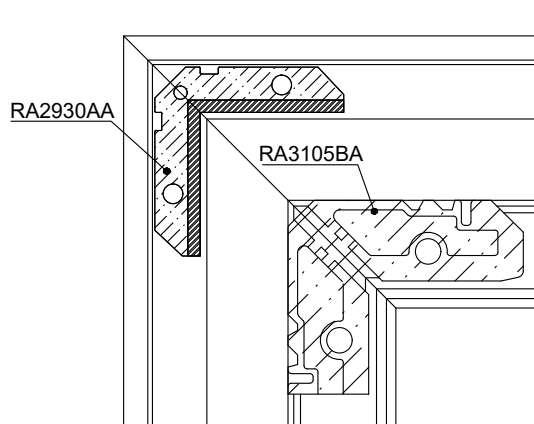
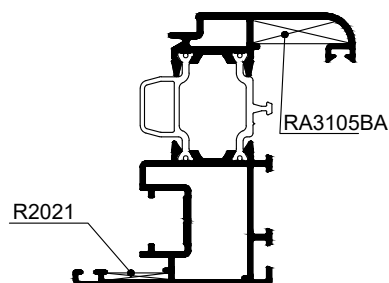
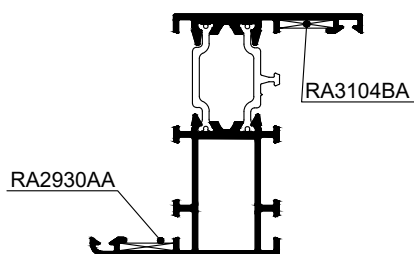
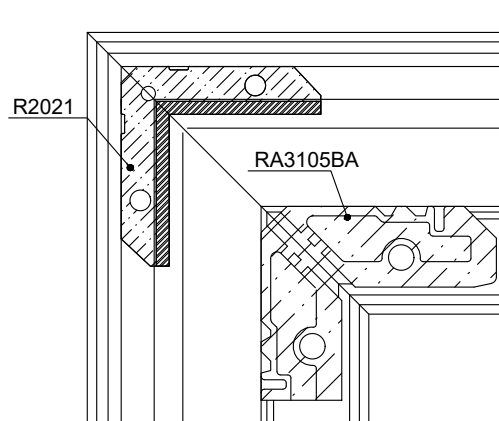
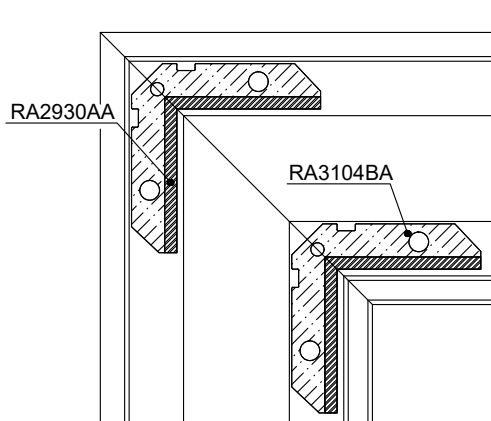

Attenzione : in corrispondenza del cardine inferiore, utilizzare squadretta RA3103ZA invece della 2021 (Mont.)
Attention : in corrispondence of the bottom hinge use corner joint RA3103ZA instead of 2021 (Mont.)

- Le squadrette di allineamento su alette, devono essere incollate con colle per alluminio di tipo epossidico bicomponente o di tipo poliuretano monocomponente

- The alignment corner joint on rabbets, must always be glued with epoxy adhesives for aluminum two-component or polyurethane component type

INTESTATURA FASCE E ZOCCOLI
BUTTING HORIZONTAL PANELS - SKIRTING BOARDS

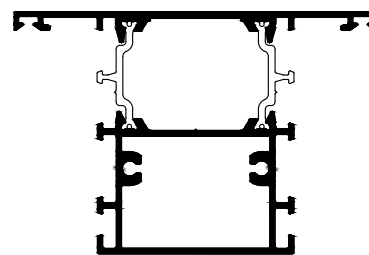
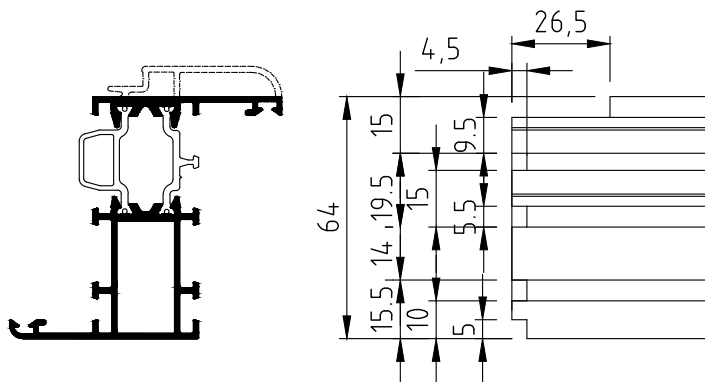

RR72C646
RR72C647
RR72C654
RR72C669
RR72C721
RR72C722

Attrezzatura: GRUPPO FRESE
Tooling: MILLING CUTTER GROUP

INTESTATURA FASCE E ZOCCOLI PER ANTE COMPLANARI
BUTTING HORIZONTAL PANELS - SKIRTING BOARDS FOR COPLANAR WINGS

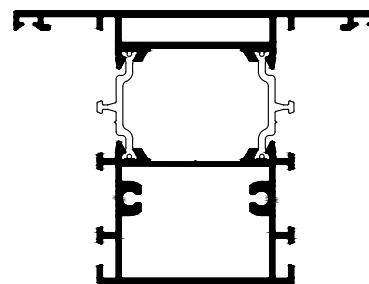
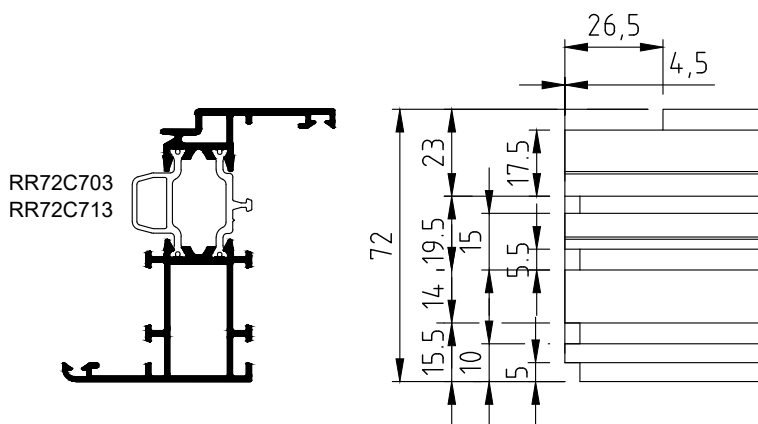

RR72C712
RR72C719

Attrezzatura: GRUPPO FRESE
Tooling: MILLING CUTTER GROUP

INTESTATURA SOGLIA PROFILATO RR72C696
BUTTING FRAME SECTIONS RR72C696

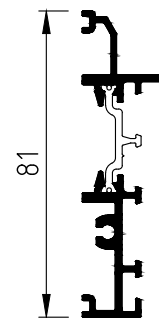
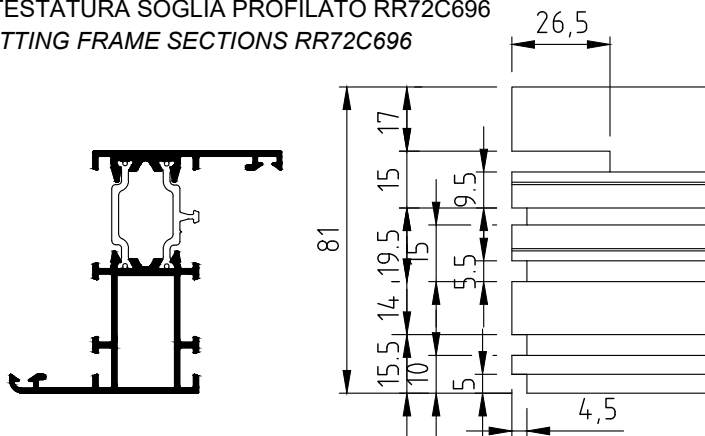

RR72C696

Attrezzatura: GRUPPO FRESE
Tooling: MILLING CUTTER GROUP

INTESTATURA SOGLIA PROFILATO R2800728
BUTTING FRAME SECTIONS R2800728

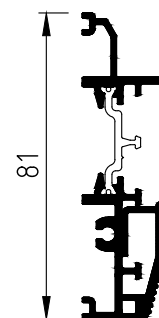
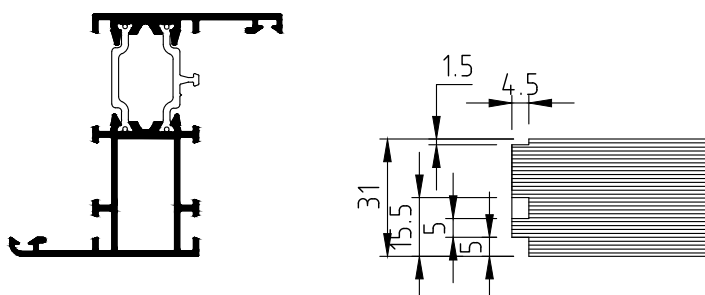

R2800728

Attrezzatura: GRUPPO FRESE
Tooling: MILLING CUTTER GROUP

INTESTATURA SOGLIA PROFILATO R2800729
BUTTING FRAME SECTIONS R2800729

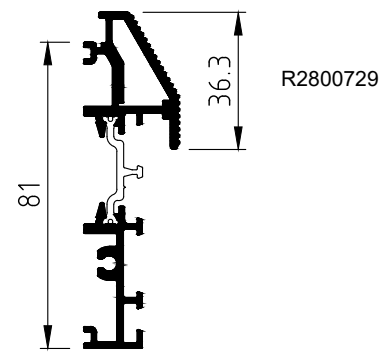
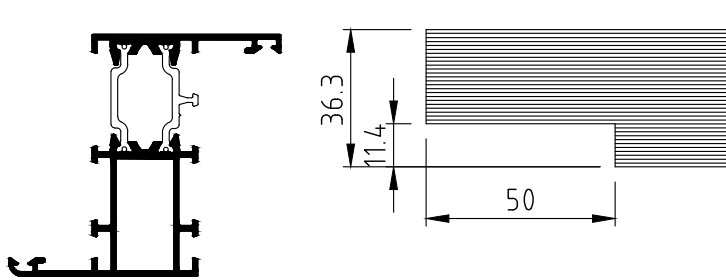

R2800729

INTESTATURA FASCE PER TELAI "TUBOLARI ESTERNI"
BUTTING HORIZONTAL PANELS FOR FRAMES "EXTERNAL TUBULAR"

Attrezzatura: FRESA
Tooling: MILLING CUTTER

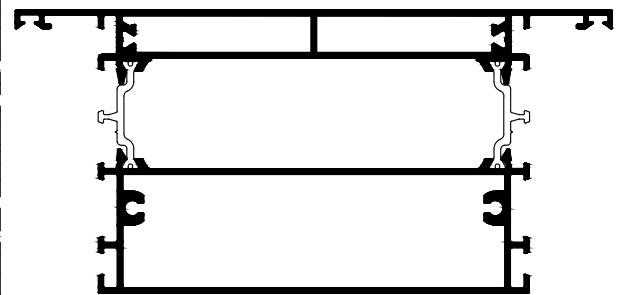
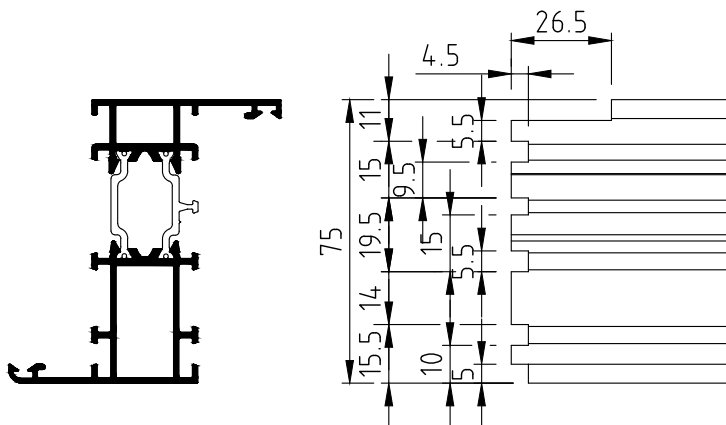

Attrezzatura: GRUPPO FRESE
Tooling: MILLING CUTTER GROUP

INTESTATURA FASCE PER ANTE "TUBOLARI ESTERNI"
BUTTING HORIZONTAL PANELS FOR WINGS "EXTERNAL TUBULAR"

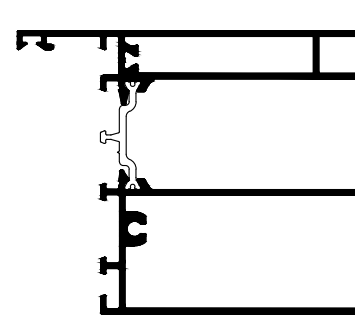
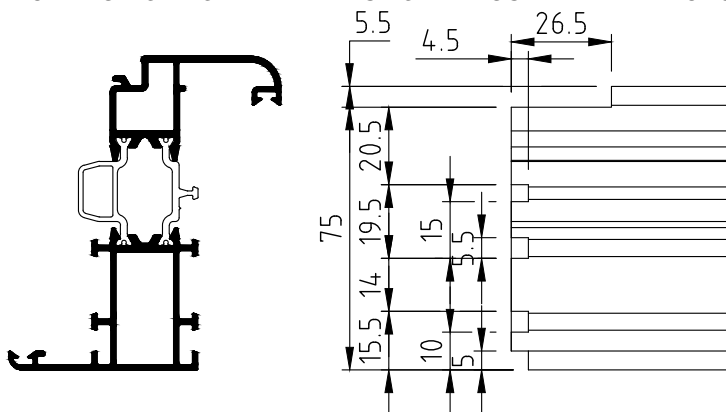

Attrezzatura: GRUPPO FRESE
Tooling: MILLING CUTTER GROUP

FORATURA PER REGOLO MOBILE
PUNCHING FOR ADJUSTABLE BLOCK

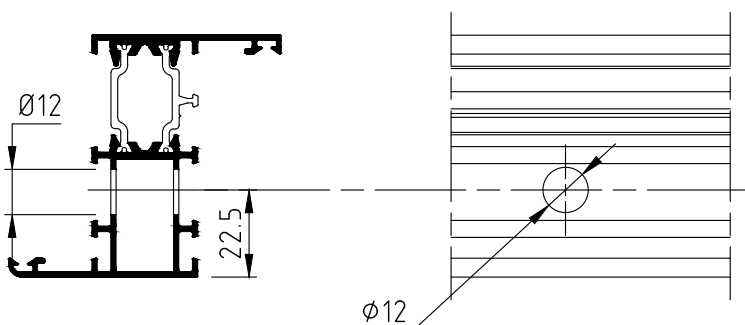

Art. RA5757ZA
RA5758ZA
RA5759ZA
RA5760ZA
RA5761ZA

Art. RA5756ZA

Attrezzatura: TRAPANO
Tooling: DRILL

CAVALLOTTI CON VITE
T JOINTS WITH SCREW

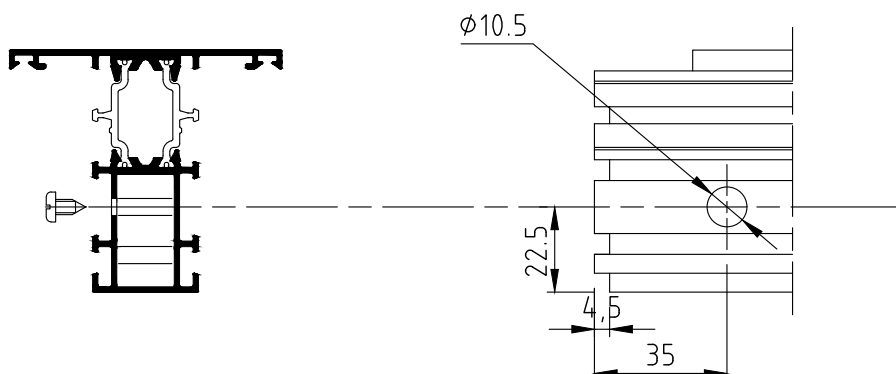

RA3207AA

Attrezzatura: TRAPANO
Tooling: DRILL

MONTAGGIO CAVALLOTTO RA3204ZA
ASSEMBLY TJOINTS RA3204ZA

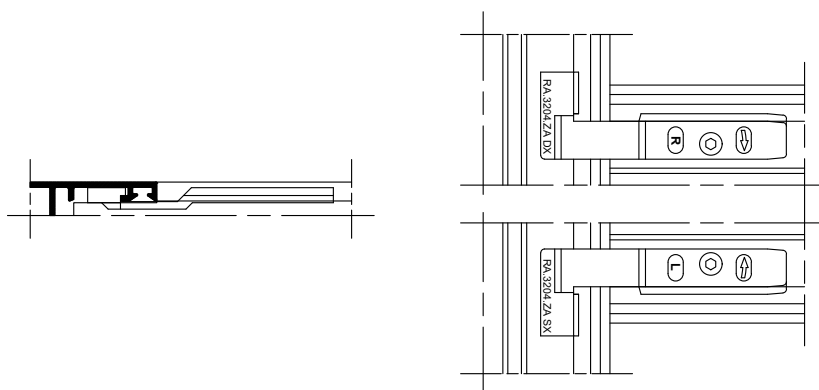

RA3204ZA

MONTAGGIO CAVALLOTTI RA3205NN E RA3206NN
ASSEMBLY TJOINTS RA3205NN AND RA3206NN

RR72C738
RR72C749

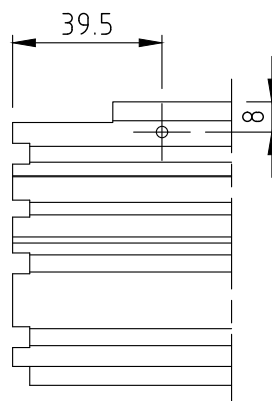
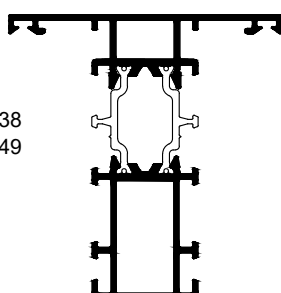

RA3205NN



RA3206NN



Attrezzatura: TRAPANO
Tooling: DRILL

FORATURA UNIONE FASCE - ZOCCOLI
PUNCHING FOR HORIZONTAL PANELS CONNECTION - SKIRTING BOARD

RR72C646
RR72C647
RR72C669

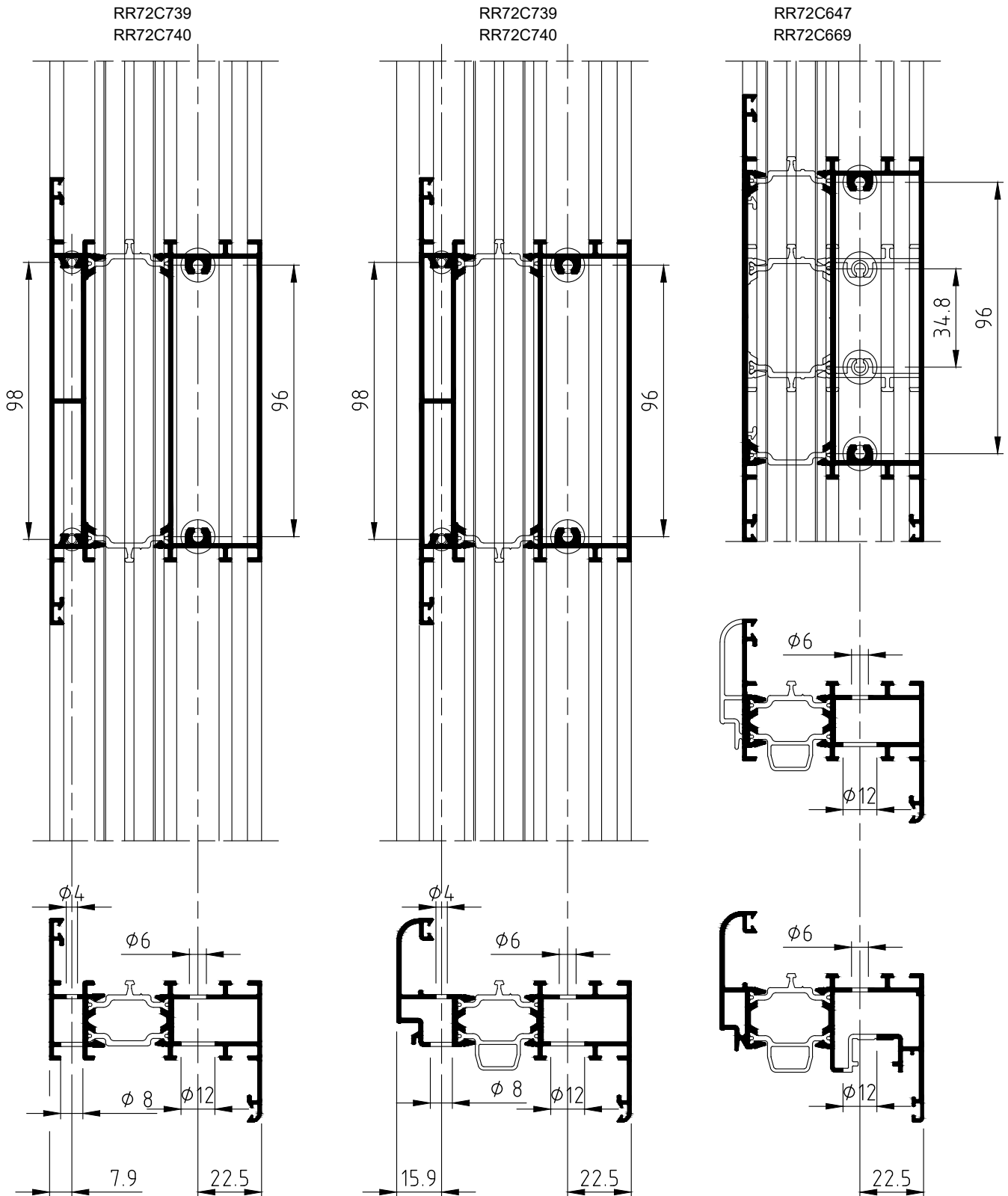

Vite da 3,5 x 20mm
Screw 3,5 x 20mm

Vite da 3,5 x 20mm
Screw 3,5 x 20mm

Attrezzatura: TRAPANO
Tooling: DRILL

FORATURA UNIONE FASCE - ZOCCOLI
PUNCHING FOR HORIZONTAL PANELS CONNECTION - SKIRTING BOARD

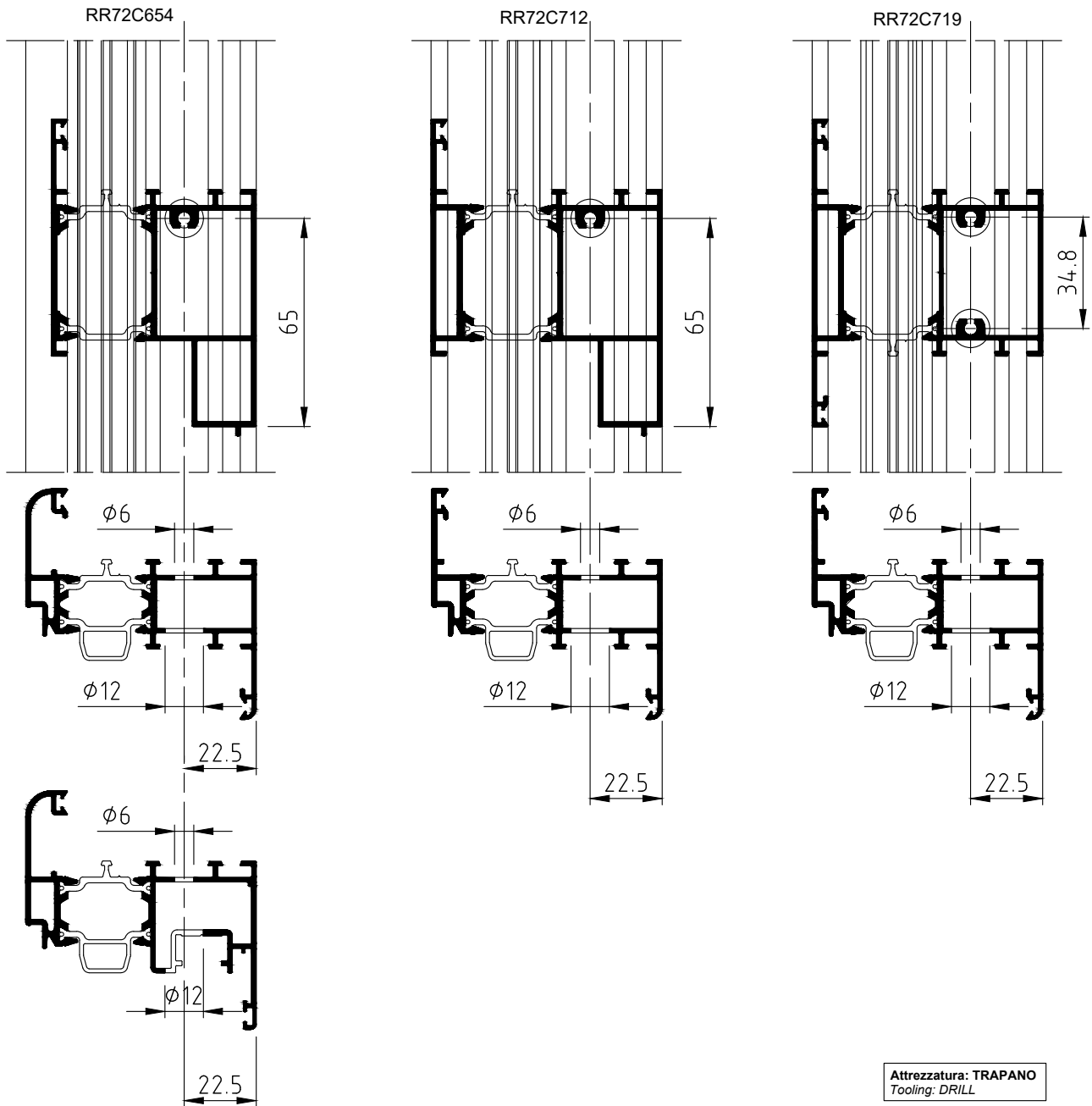

FORATURA SOGLIA
PUNCHING FOR FRAME CONNECTION

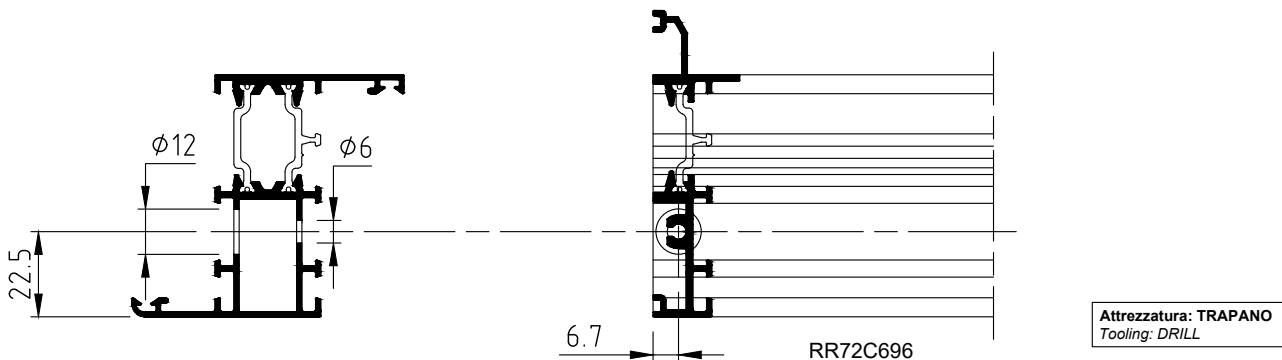

LAVORAZIONE DEFLUSSO ACQUA
TOOLING WATER DRAINAGE

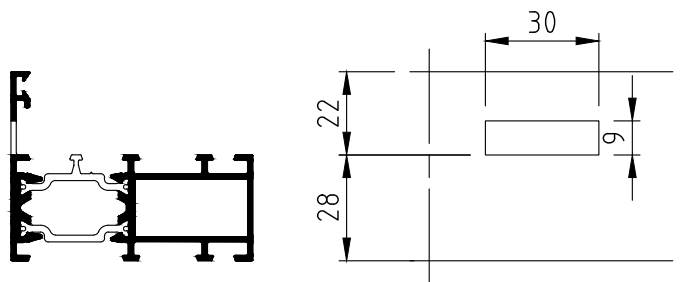

Art. RA5753NV
RA5532NN

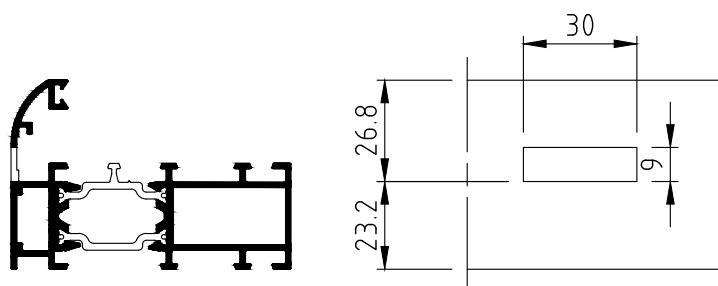
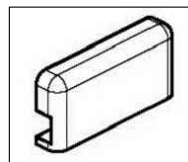

Art. RA5753NV
RA5532NN

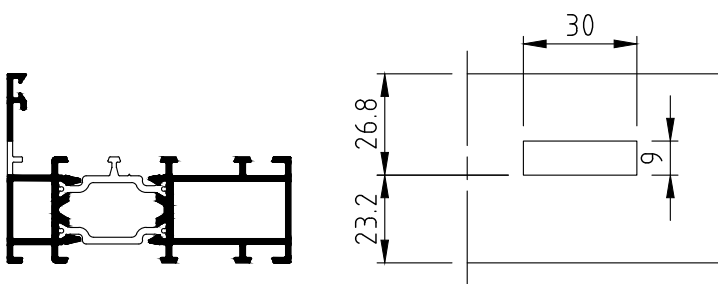
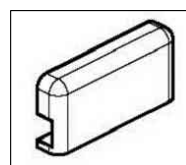

Art. RA5753NV
RA5532NN

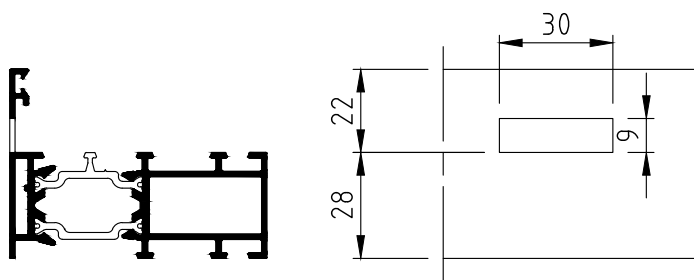
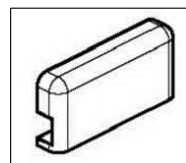

Art. RA5753NV
RA5532NN

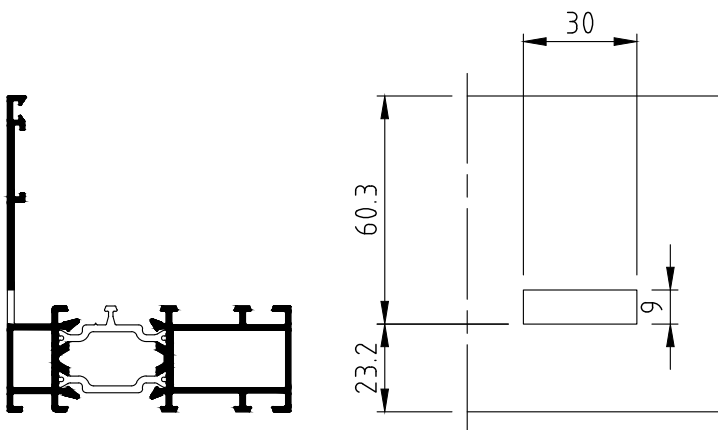
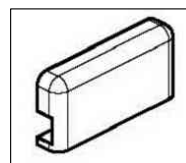

Art. RA5753NV
RA5532NN

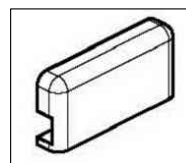

Attrezzatura: PUNZONATRICE
Tooling: PUNCHING MACHINE

LAVORAZIONI PER SCARICHI ACQUA E VENTILAZIONE VETRI
PROCESSING FOR WATER DRAINAGE AND GLASS VENTILATION

Posizione scarichi acqua
Water drainages position

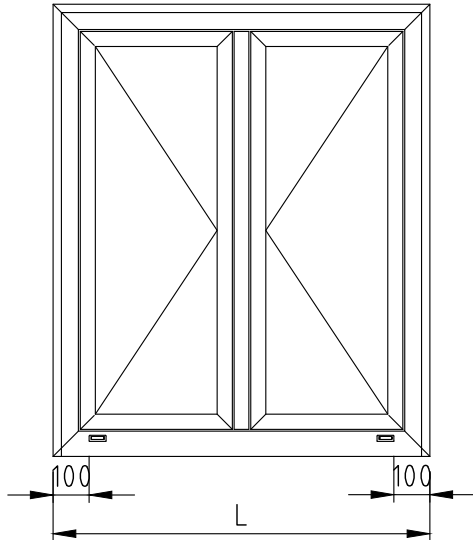

Scarichi acqua:
N° 2 Per $L \leq 1200$ mm
N° 3 Per $L > 1200$ mm ≤ 2100 mm
N° 4 Per $L > 2100$ mm ≤ 2800 mm

Water drains:
N° 2 For $L \leq 1200$ mm
N° 3 For $L > 1200$ mm ≤ 2100 mm
N° 4 For $L > 2100$ mm ≤ 2800 mm

Posizione ventilazione vetri
Glass ventilation position

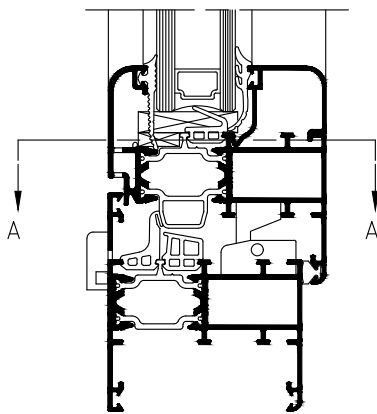
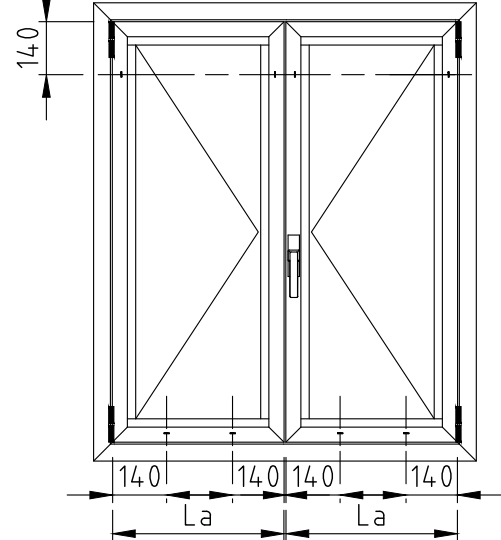

Sez. A-A

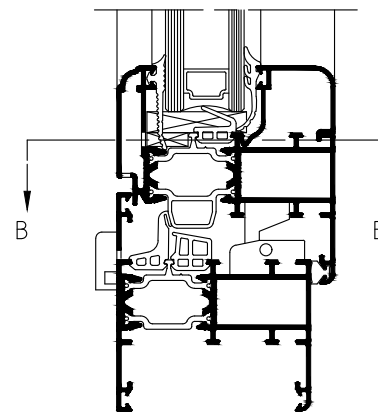
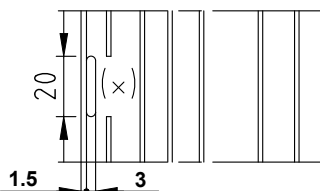

Sez. B-B

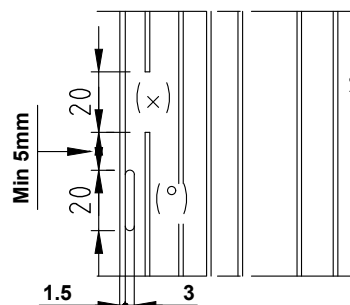

(*) Asportazione dentino solo su profilato anta (* Asola da 20x 5mm spostata rispetto all'altra lavorazione (* Asola da 20x 3mm spostata rispetto all'altra lavorazione
lato inferiore in corrispondenza scarico acqua (*) Asola da 20x 3mm in corrispondenza dello scarico acqua (*) Asola da 20x 3mm in corrispondenza dello scarico acqua
Teeth removal only on lower wing section corresponding to the water drainage hole (*) Slot 20x5mm not corresponding to the other tooling (*) Slot 20x3mm not corresponding to the other tooling
(*) Slot 20x5mm corresponding to the water drainage hole (*) Slot 20x3mm corresponding to the water drainage hole (*) Slot 20x3mm corresponding to the water drainage hole

Attrezzatura: TRAPANO - PANTOGRAFO
Tooling: DRILL - PANTOGRAPH

LAVORAZIONI PER SCARICHI ACQUA E VENTILAZIONE VETRI
PROCESSING FOR WATER DRAINAGE AND GLASS VENTILATION

TUBOLARI ESTERNI RIDOTTI
REDUCED EXTERNAL TUBULARS

Posizione scarichi acqua
Water drainages position

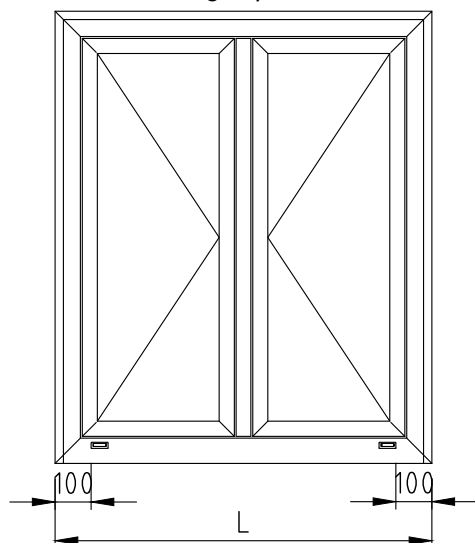

Scarichi acqua:
N° 2 Per $L \leq 1200$ mm
N° 3 Per $L > 1200$ mm ≤ 2100 mm
N° 4 Per $L > 2100$ mm ≤ 2800 mm

Water drains:
N° 2 For $L \leq 1200$ mm
N° 3 For $L > 1200$ mm ≤ 2100 mm
N° 4 For $L > 2100$ mm ≤ 2800 mm

Posizione ventilazione vetri
Glass ventilation position

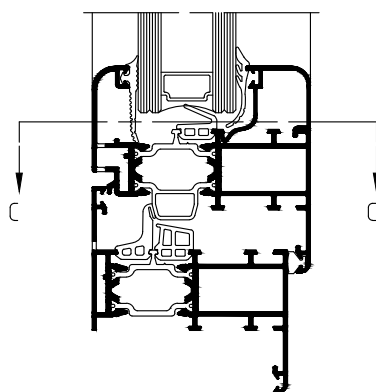
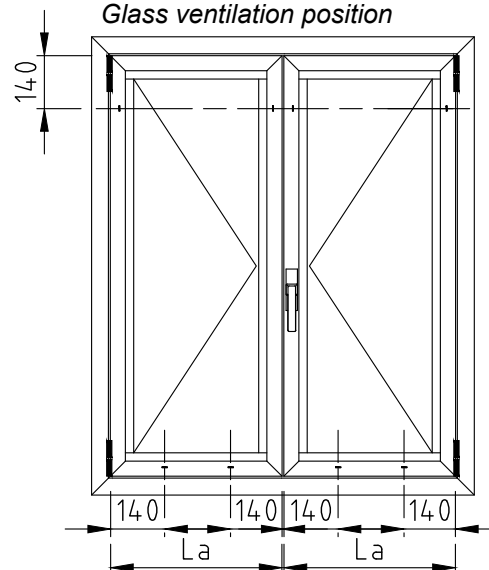

Sez. C-C

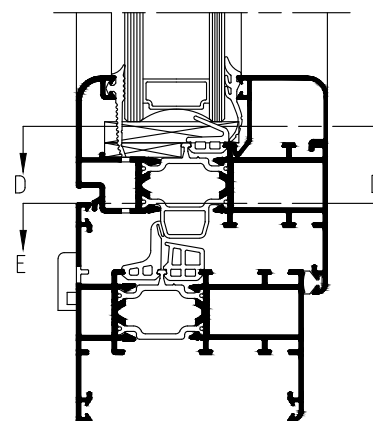
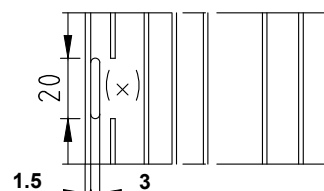

Sez. D-D

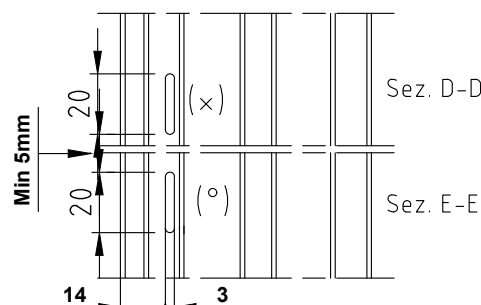

(*) Asportazione dentino solo su profilato anta (* Asola da 20x 5mm spostata rispetto all'altra lavorazione (* Asola da 20x 3mm spostata rispetto all'altra lavorazione
lato inferiore in corrispondenza scarico acqua (* Asola da 20x 3mm in corrispondenza dello scarico acqua (* Asola da 20x 3mm in corrispondenza dello scarico acqua
Teeth removal only on lower wing section corresponding to the water drainage hole (* Slot 20x5mm not corresponding to the other tooling (* Slot 20x3mm not corresponding to the other tooling
(* Slot 20x5mm corresponding to the water drainage hole (* Slot 20x3mm corresponding to the water drainage hole (* Slot 20x3mm corresponding to the water drainage hole

Attrezzatura: TRAPANO - PANTOGRAFO
Tooling: DRILL - PANTOGRAPH

LAVORAZIONE PER MONTAGGIO APPOGGIO VETRO " RA2834AA "
PROCESSING FOR INSERT GLASS SUPPORT " RA2834AA "

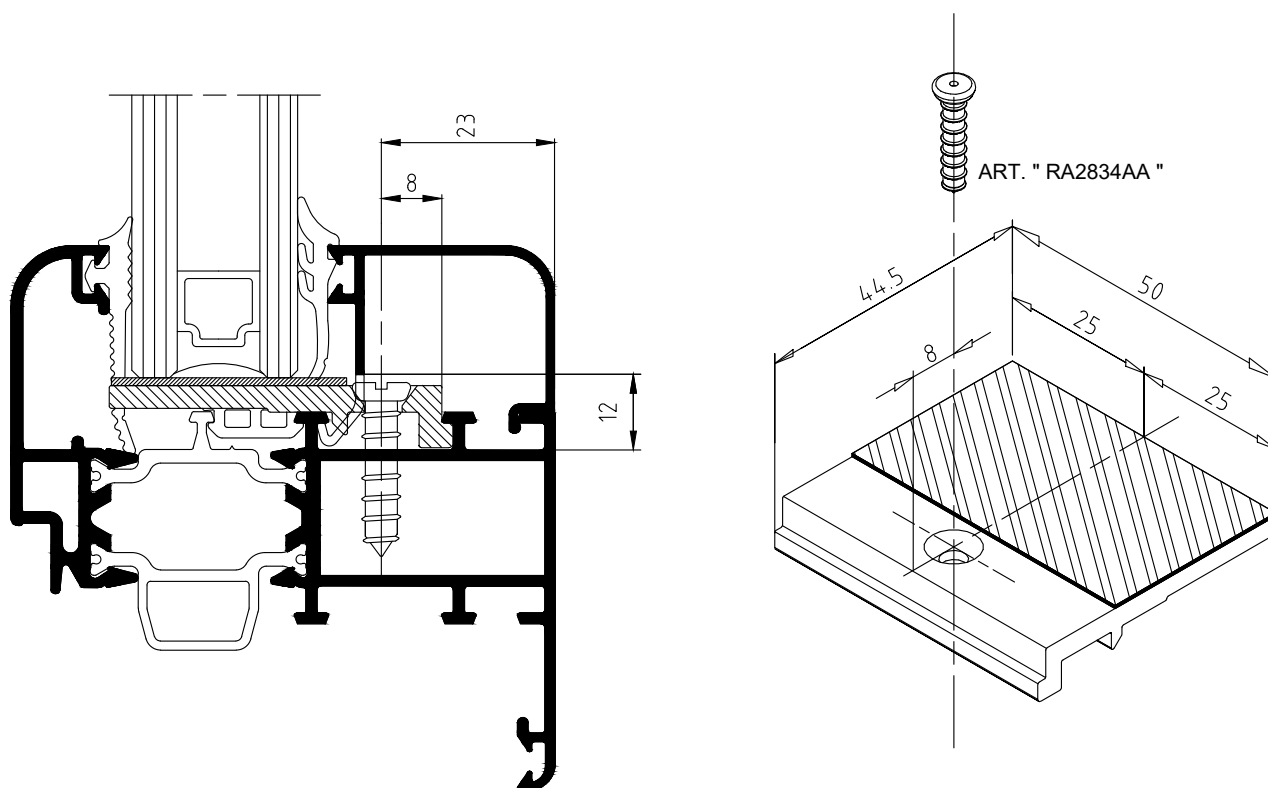

ART. " RA2834AA "

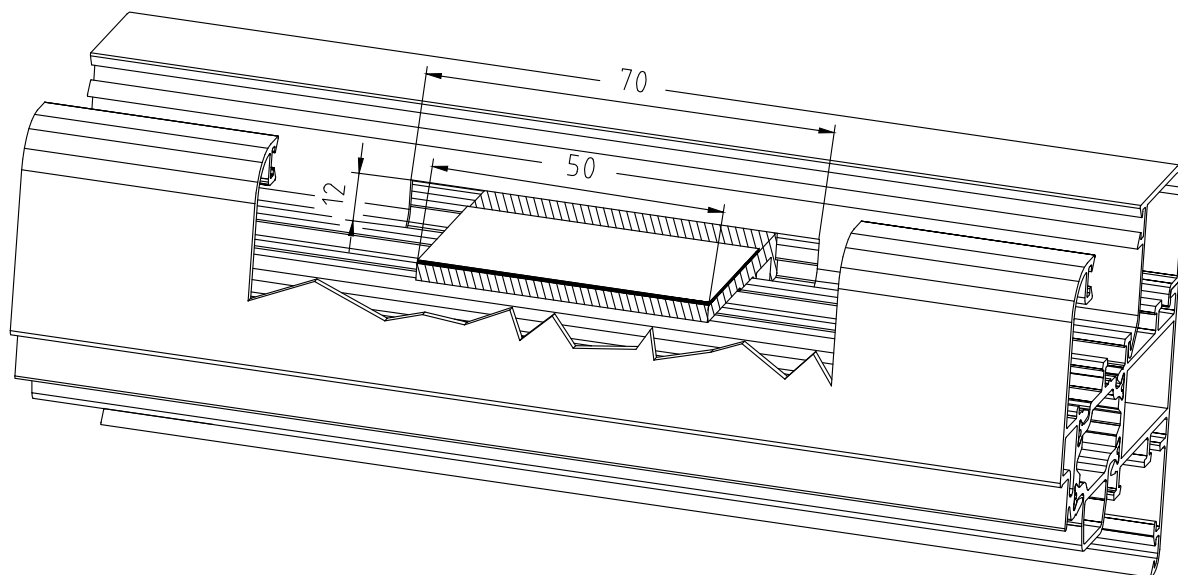

LAVORAZIONE PER MONTAGGIO APPOGGIO VETRO " RA2833AA "
PROCESSING FOR INSERT GLASS SUPPORT " RA2833AA "

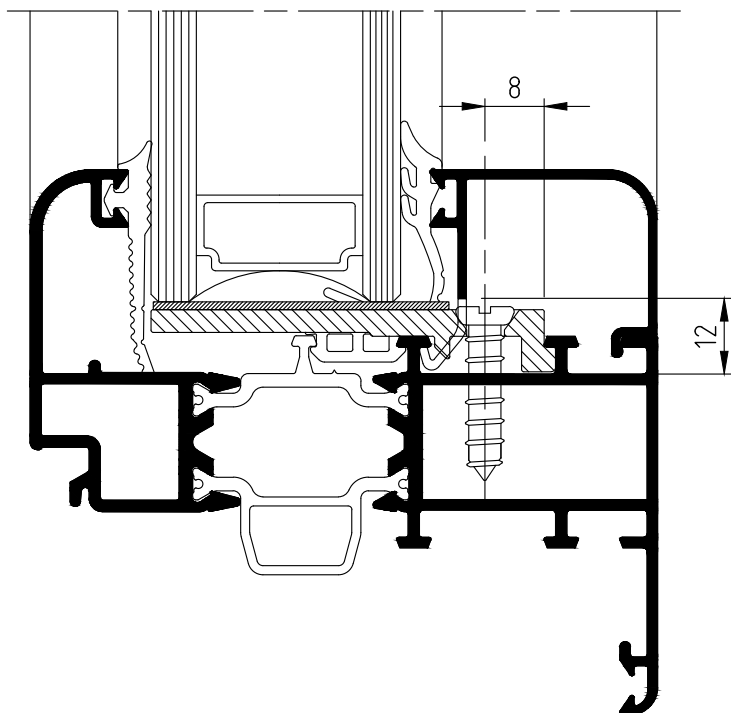

ART. " RA2833AA "

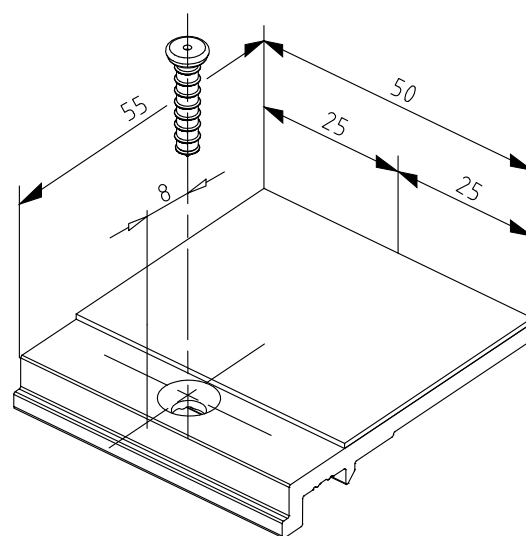

ART. " RA2833AA "

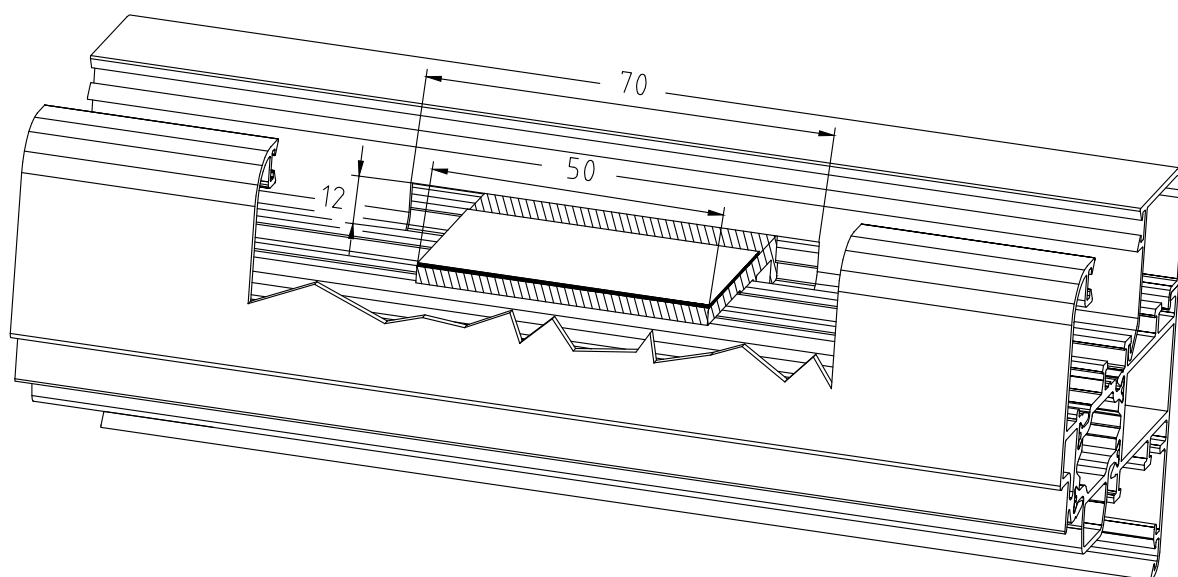

TUBOLARI ESTERNI RIDOTTI
REDUCED EXTERNAL TUBOLARS
MONTAGGIO APPOGGIO VETRO "RA2834AA"
INSERT GLASS SUPPORT "RA2834AA"

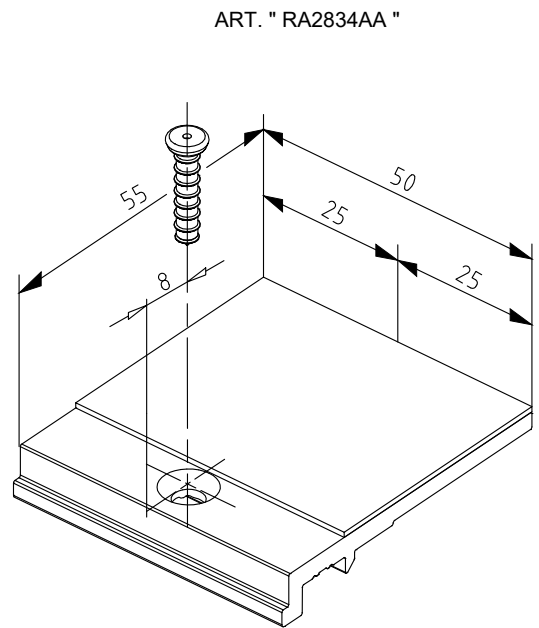
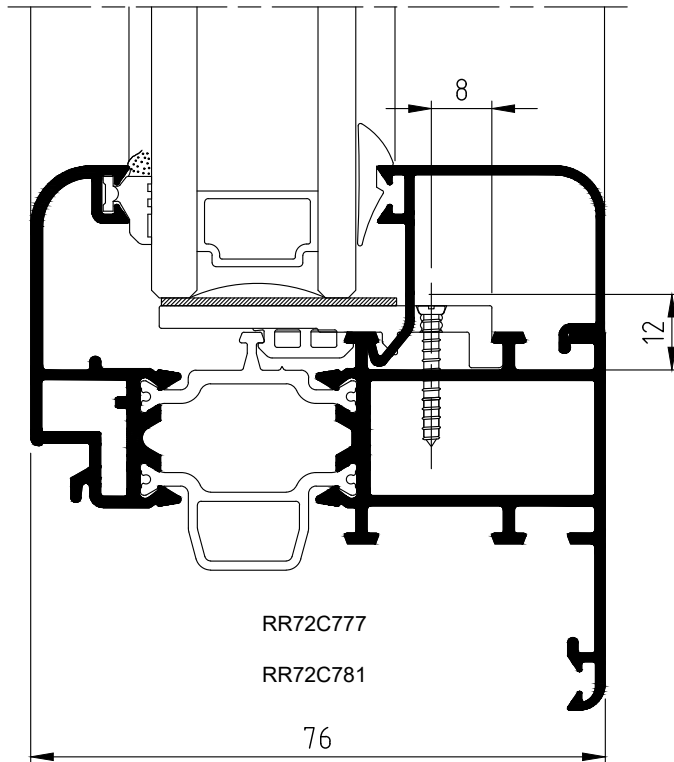

ART. "RA2834AA "

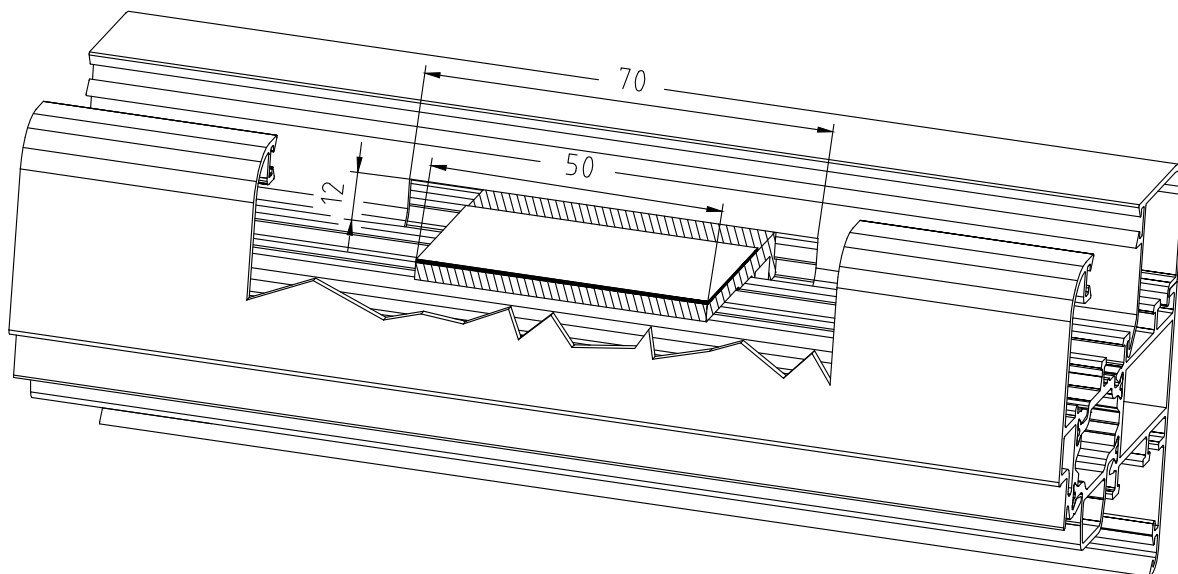

LAVORAZIONI
TOOLINGS

FISSAGGIO DI SICUREZZA PER FERMAVETRI
EXTERNAL GLAZING BEADS SECURITY FIXATION BY SCREWS

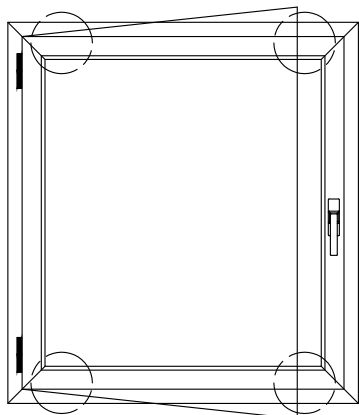

Vite TPS 3,5 x 19mm
3,5 x 19mm flat head screw

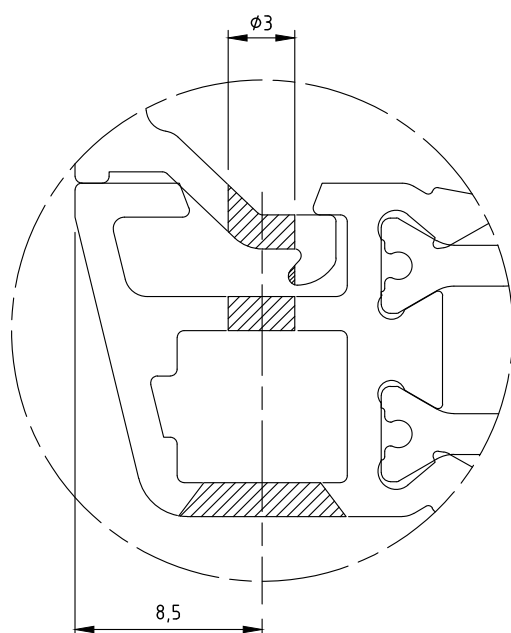
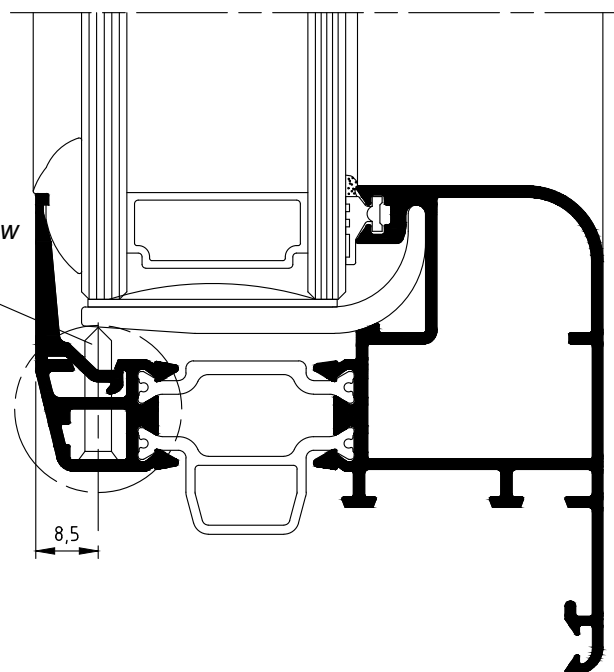

Eseguire pre foro da 3mm
e svasatura per vite TPS 3,5 x 19
*Make a 3mm pre-hole and a
countersink for a 3,5x19mm flat
head screw.*

Attrezzatura: TRAPANO
Tooling: DRILL

POSIZIONAMENTO FISSAGGIO ART. 508.025.01
MOUNTING POSITION ART. 508.025.01

ART. 508.025.01

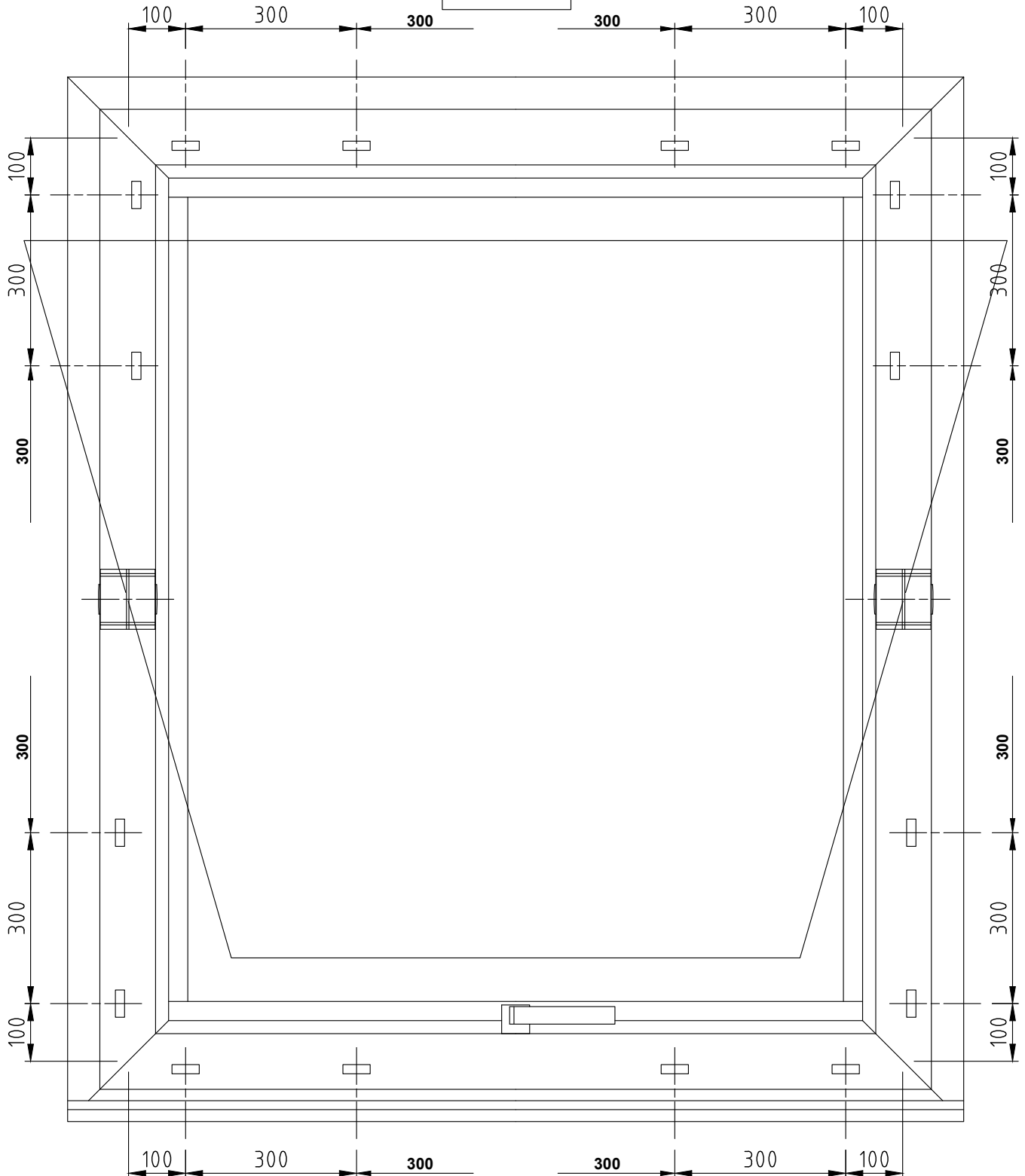

SEZIONI - TAPPO PER RIPORTO CENTRALE "R2R72C38" SECTIONS - PLUG FOR CENTRAL FILLING "R2R72C38"

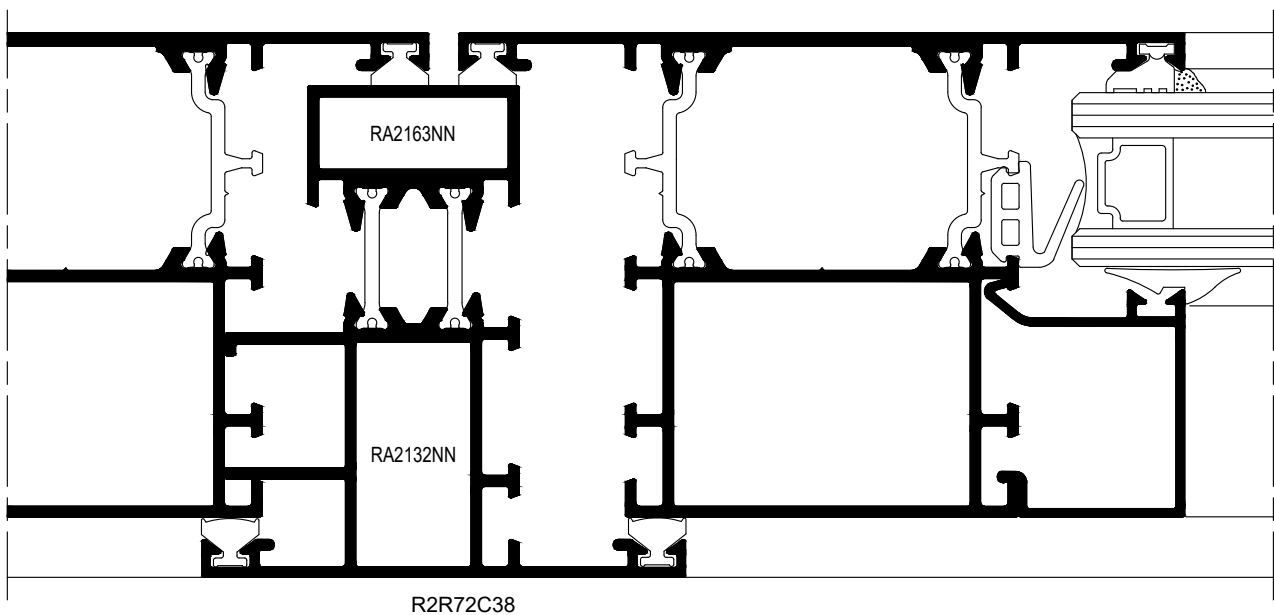
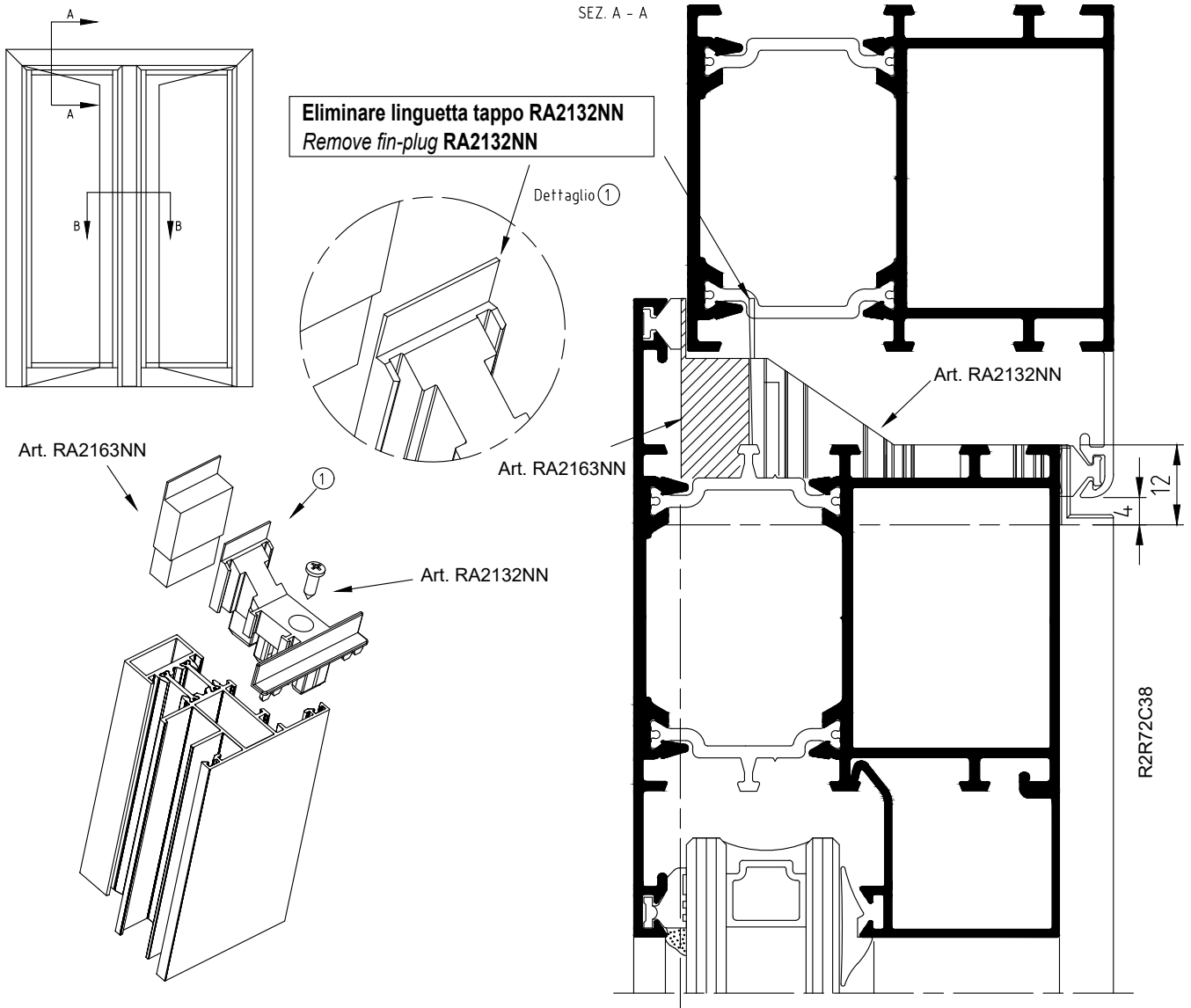

MONOBLOCCO
MONOBLOCK

INTESTATURA TRAVERSO
BUTTING TRAMSOM

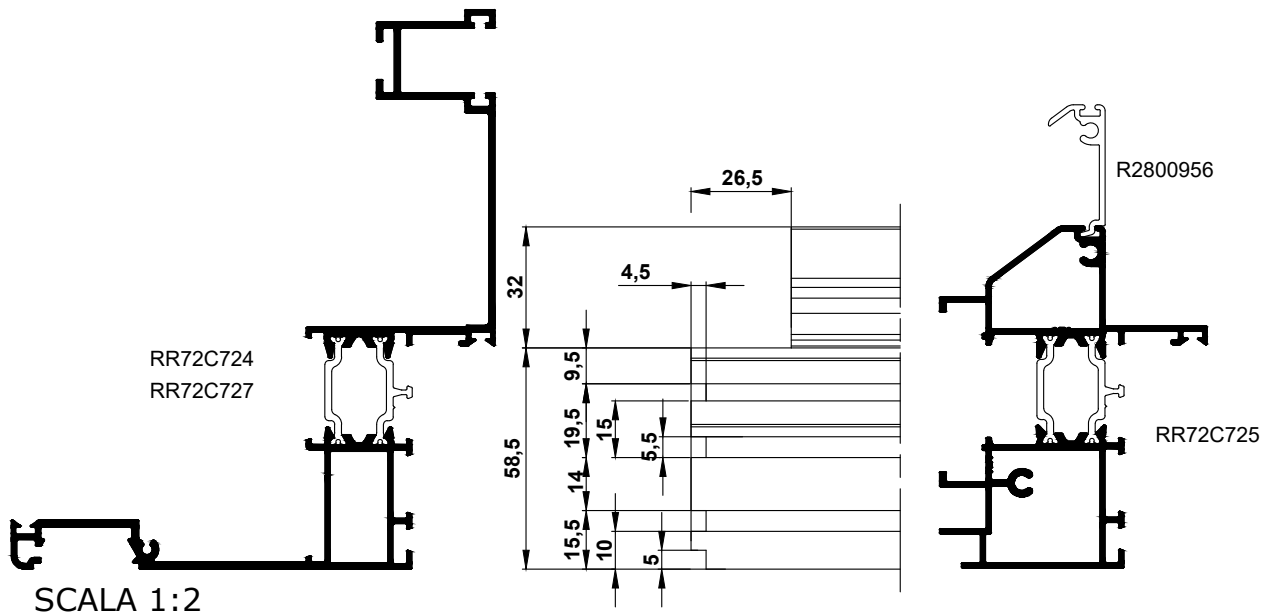

SCALA 1:2

Attrezzatura: GRUPPO FRESE
Tooling: MILLING CUTTER GROUP

FORATURA MONTANTE PER FISSAGGIO TRAVERSO
DRILLING OF MULLION FOR FIXING ON THE TRANSOM

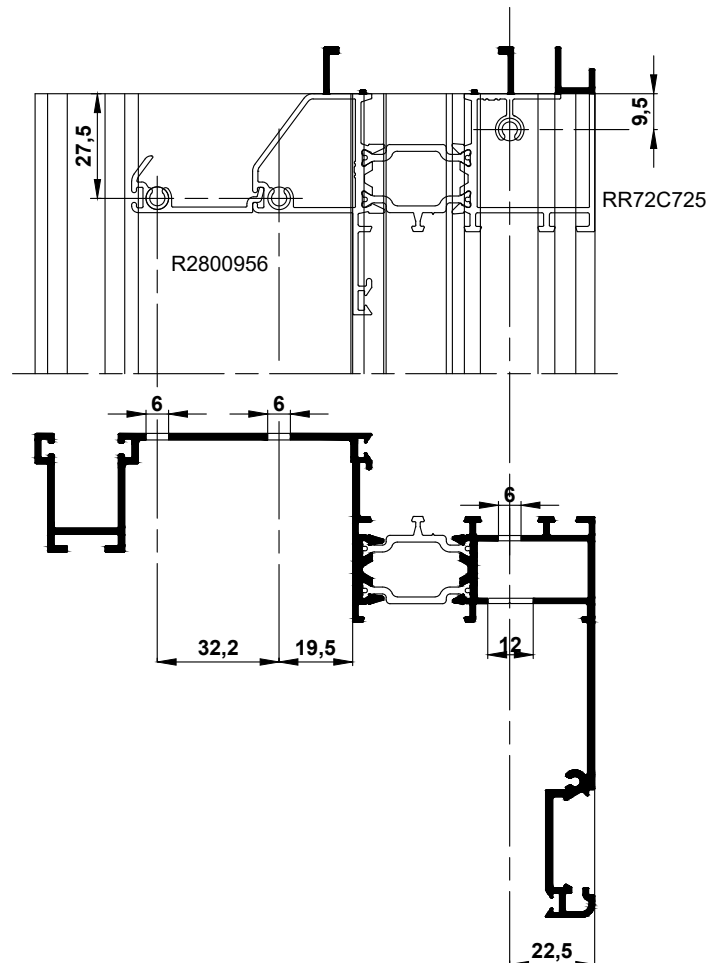

SCALA 1:2

Attrezzatura: TRAPANO
Tooling: DRILL

MONOBLOCCO
MONOBLOCK

INSERIMENTO SCATOLA AVVOLGIBILE
INSERTING THE BOX FOR THE ROLLING BLIND

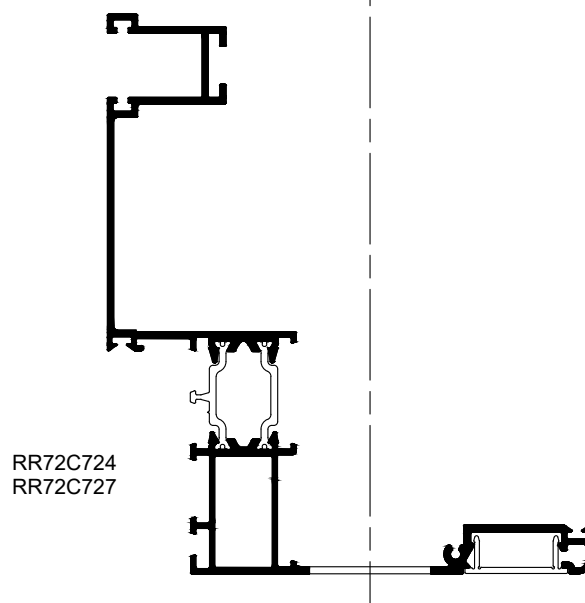
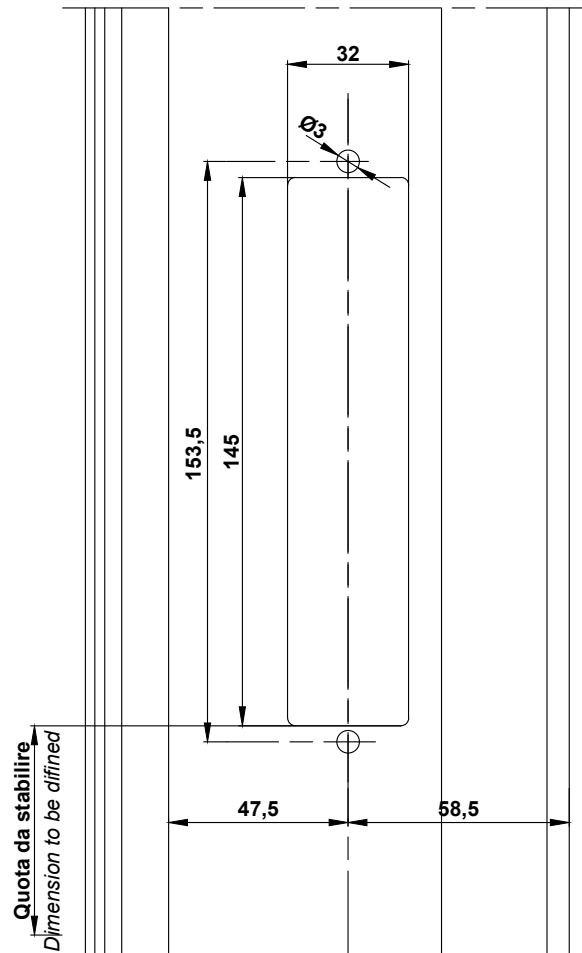

RR72C724
RR72C727

SCALA 1:2

Attrezzatura: PANTOGRAFO
Tooling: PHANTOGRAF

MONOBLOCCO
MONOBLOCK

INSERIMENTO RULLINO PASSACINGHIA
INSERT THE ROLL FOR THE BELT

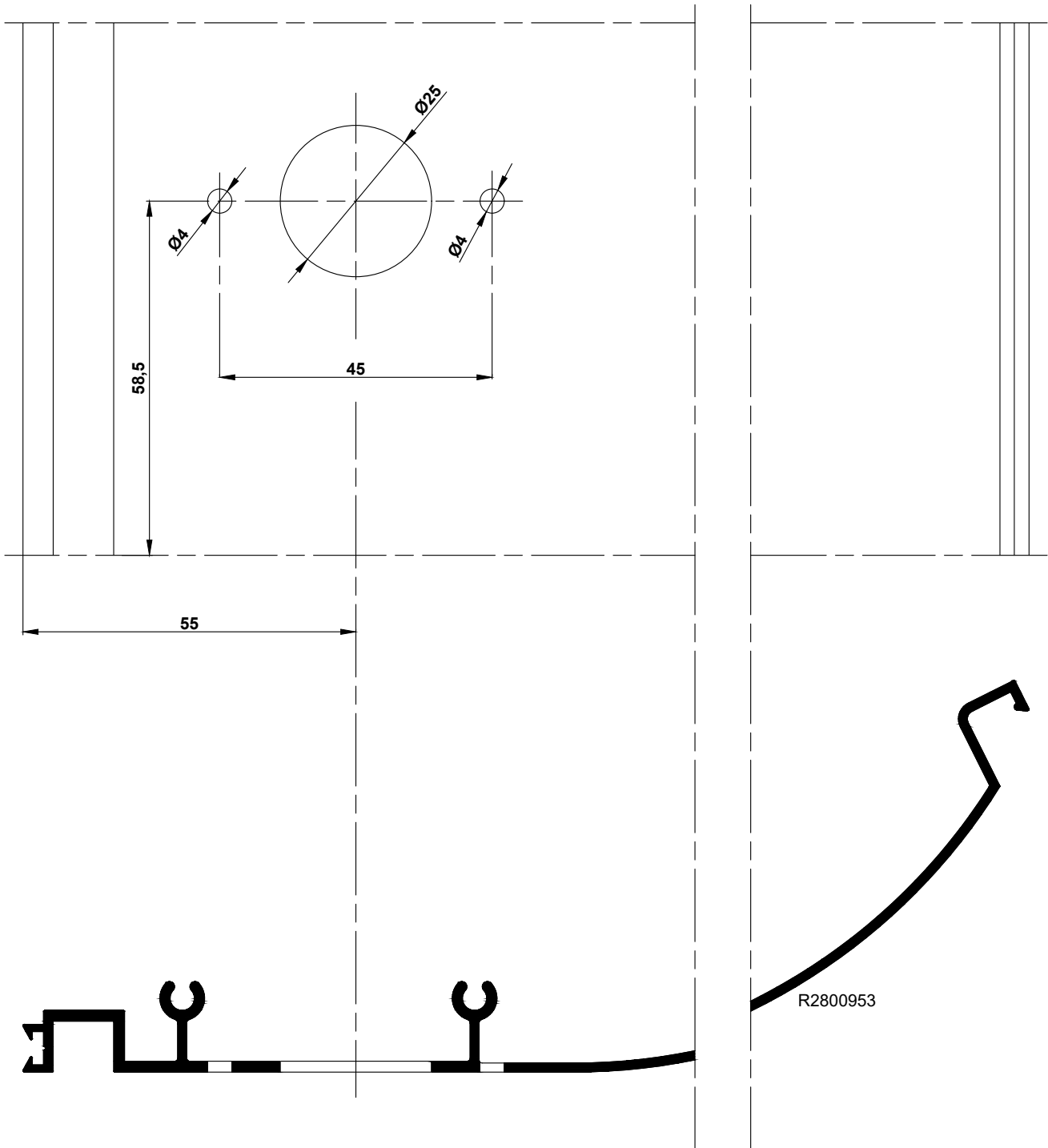

SCALA 1:1

Attrezzatura: TRAPANO
Tooling: DRILL

OS sviluppa, produce e commercializza in tutto il mondo profili a valore aggiunto. Hydro Building Systems Italy Spa sviluppa, produce e commercializza profili per l'edilizia sempre innovativi. Original Systems garantisce una vasta e completa gamma di soluzioni residenziali e non, per rispettare e normative e per soddisfare le esigenze più complesse del mercato dell'involucro edilizio. I marchi Original Systems Sistema RTT, Sistema R, Sistema DS, Teknowall, Teknowindow e CETT, sono distribuiti solo attraverso la rete Ufficiale di Distributori OS.



e scegli con serenità.



Hydro Building Systems Italy Spa
Via A. Ponchielli 3, 20063
Cernusco sul Naviglio (MI)
T: + 02 92 42 91
F: 02 92 42 94 96
www.originalsystems.it