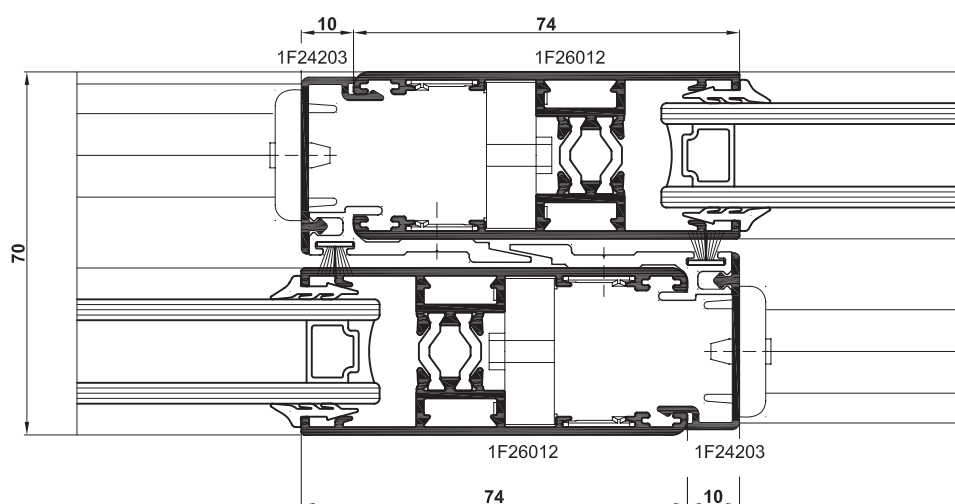
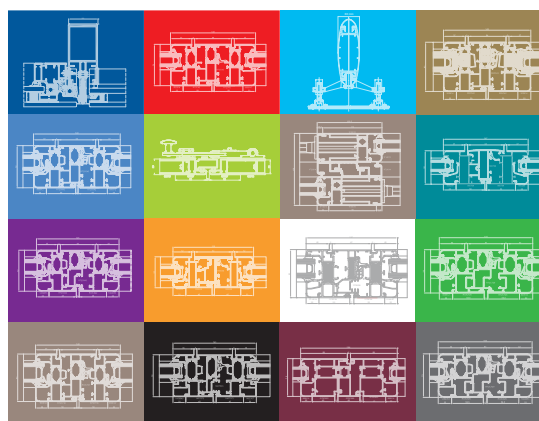

Original Systems[®]**Teknowindow****WIN** 65s^{TT} SYSTEM - **WIN** 65s SYSTEM

Scorrevole - Sliding

Un solo sistema, progettato organicamente sia nei profilati sia negli accessori e nelle guarnizioni, basta per rispondere a tutte le esigenze dimensionali, tecnologiche ed architettoniche che il mercato richiede.

One single system, organically designed for profiles, accessories and weatherstrips, is enough to fulfill the dimensional, technological and architectural demands of the market.

**Sapa Profili Srl**

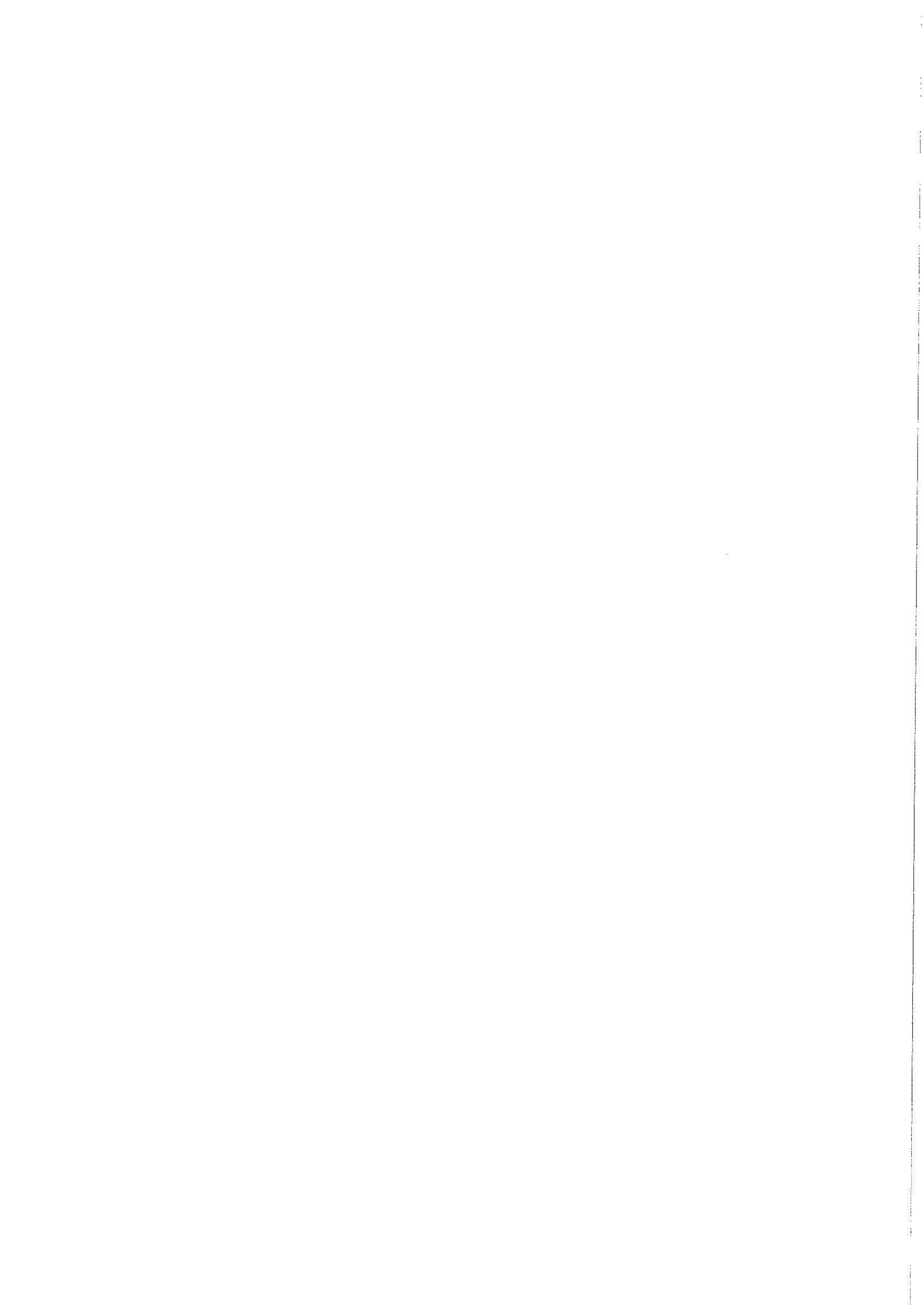

sapa:

WIN 65s^{TT}
SYSTEM

WIN 65s
SYSTEM

Finestre e porte scorrevoli con e senza taglio termico
Windows and sliding doors with or without thermal break

About the Sapa Group

Sapa develops, manufactures and markets value added profiles, profile-based building systems and heat-exchanger strip in the light-weight material aluminium and is one of the world's leading manufacturers.

Sapa's business concept is based on close co-operation with its customers, who are primarily located in Europe, North America and Asia. The largest customer segments are the construction, transport, domestic and office, and engineering sectors.

Sapa is organised into six Business Areas: Profiles North Europe, Profiles Central Europe, Profiles South Europe, Profiles North America, Building System and Heat Transfer.

Sapa Profiles

Sapa is the world's leading producer of extruded aluminium profiles and maintains extensive operations in the value-added fabrication of profiles.

The company has 111 presses and more than 12.000 employees and production facilities in 18 countries: Belgium, China, Denmark, France, Germany, Hungary, Italy, Lithuania, Mexico, the Netherlands, Poland, Portugal, Romania, Slovakia, Spain, Sweden, the United Kingdom and the United States, plus sales representation in a number of additional countries.

With footprints in North and Central America, Europe and Asia we can serve customers on a worldwide basis.

Sapa Profili Srl

With 3 plants in Italy and the support of the rest of the group, Sapa Profili Srl is one of the largest extrusion companies within Italy.

Soft- and hard-alloy aluminium extrusions, standard rod and bars, seamless tube (round or shaped), simple or complex aluminium extrusion profiles (drawings), high fin ratio, tight tolerances with superior surface finish quality, or other demanding high-tech applications... There is a simple solution to almost any design problem: aluminium profiles by Sapa. The solutions are based on our unique experience in extrusion and our focus on the local market.

Sapa Profili Srl strategy is providing its customers with expertise, high quality and resources, releasing capacity to allow them to concentrate on their core operations. It's all about creating competitive, comprehensive solutions.

Il gruppo Sapa

Sapa sviluppa, produce e commercializza profili a valore aggiunto, profili per l'edilizia e scambiatori di calore in alluminio. Sapa è un leader tra i produttori nel mondo.

Un elemento determinante per il concetto di business di Sapa è la stretta collaborazione con il cliente maggiormente basati in Europa, Nord America ed Asia. I segmenti di mercato maggiori sono quelli dell'edilizia, il settore trasporti, casa ed uffici ed il settore della meccanica.

La Sapa è suddivisa in sei aree: Profili Nord Europa, Profili Europa centrale, Profili Sud Europa, Profili Nord America, Sistemi per l'edilizia ed il settore per gli scambiatori di calore.

Sapa Profili

Sapa è il maggior produttore di profili estrusi al mondo.

Questa nuova azienda dispone di 111 presse con oltre 12.000 dipendenti e con centri di produzione in 18 paesi: Belgio, Cina, Danimarca, Francia, Germania, Ungheria, Italia, Lituania, Messico, Olanda, Polonia, Portogallo, Romania, Slovenia, Spagna, Svezia, Gran Bretagna e negli stati uniti oltre ad avere rappresentanti commerciali in altri paesi.

Grazie alla presenza in America del Nord e Centrale, Europa ed Asia, possiamo servire i clienti in tutto il mondo.

Sapa Profili Srl

Con i 3 stabilimenti produttivi in Italia ed il supporto del resto del gruppo la Sapa Profili Srl diventa uno dei maggiori estrusori in Italia.

Estrusioni di alluminio in lega leggera o dura, profili standard o barrame, tubi tondi o a disegno senza saldature, profili estrusi semplici o complessi a disegno, elevato rapporto di atletatura, tolleranze ristrette con qualità superficiale elevata o qualsiasi altra esigenza per applicazioni high tech... esiste una semplice soluzione a quasi tutte le esigenze di design: profili in alluminio Sapa. Le soluzioni basano sulla nostra esperienza unica e focalizzata sul mercato locale..

La strategia di Sapa Profili Srl è quella di fornire al cliente competenza, qualità superiore e risorse, per permettere loro di concentrarsi sulle proprie operazioni essenziali. Plasmiamo il futuro creando soluzioni comprensive e competitive.

sapa:



Teknowindow
Scorrevole - Sliding

Sapa keys to Build the future

Since its beginnings Sapa has been recognized as an innovator. Through the years, we've balanced experience with innovation. We've listened to our customers, and we are dedicated to providing the tools our customers need to succeed.

Following this spirit, in the market of B&C Sapa offers a comprehensive line of architectural aluminum building products and systems for residential and non-residential buildings framing systems, windows and curtain wall systems.

In Italian B&C market, Teknowindow offers the most complete and advanced technological solution to construct doors and windows.

The primary value of Teknowindow system is the capability to propose a complete system, able to satisfy with compatible profiles, accessories and gaskets all the markets needs, both for its technical and architectural characteristics.

From the smallest Win54 to the largest Win140s sections, from the "cold" to the thermal-break solutions (up to class 1.0), from the various types of opening (casement window, tilt-and-turn window, pivoting window, sliding window, lifting-sliding window, etc.) to the different aesthetic forms (squared, blunt, rounded, unframed, etc.), this system is able to satisfy whatever need.

High performance levels and manufacturing and assembling simplicity make this a state-of-the-art system in the Italian and foreign market.



Le chiavi Sapa per costruire il futuro

Fin dalle sue origini, Sapa è stata riconosciuta come innovatrice. Attraverso gli anni, abbiamo equilibrato l'esperienza con l'innovazione. Abbiamo ascoltato i nostri clienti e ci siamo dedicati a fornir loro i mezzi necessari per avere successo.

Seguendo questo spirito, nel mercato dell'edilizia, Sapa offre una completa linea di prodotti architettonici in alluminio e sistemi strutturali per edifici residenziali e non, finestre e pareti divisorie.

Nel mercato dell'edilizia, il sistema Teknowindow offre le soluzioni tecnologiche più complete ed avanzate per costruire porte e finestre.

Il pregio principale del sistema Teknowindow è dato dalla capacità di proporre un sistema completo, in grado di soddisfare con profilati, accessori e guarnizioni compatibili tra loro, tutte le esigenze del mercato, sia per quanto riguarda le caratteristiche tecniche che quelle architettoniche.

Dalle sezioni più piccole della Win54 a quelle maggiori della Win140s, dalle soluzioni "fredde" a quelle a Taglio Termico (sino alla classe 1.0), dai vari tipi di apertura (a battente, ad anta-ribalta, a bilico, a scorrevole, ad alza-e-scorri, ecc.) alle differenti forme estetiche (squadrata, smussata, arrotondata, scorniciata, ecc.), questo sistema è in grado di soddisfare ogni necessità.

Livelli prestazionali elevati, uniti alla facilità di lavorazioni e di montaggio, ne fanno un sistema all'avanguardia nel panorama dell'edilizia in Italia ed all'estero.

sapa:



Teknowindow
Scorrevole - Sliding

Original Systems®
sapa:

Le serie dei sistemi di Sapa

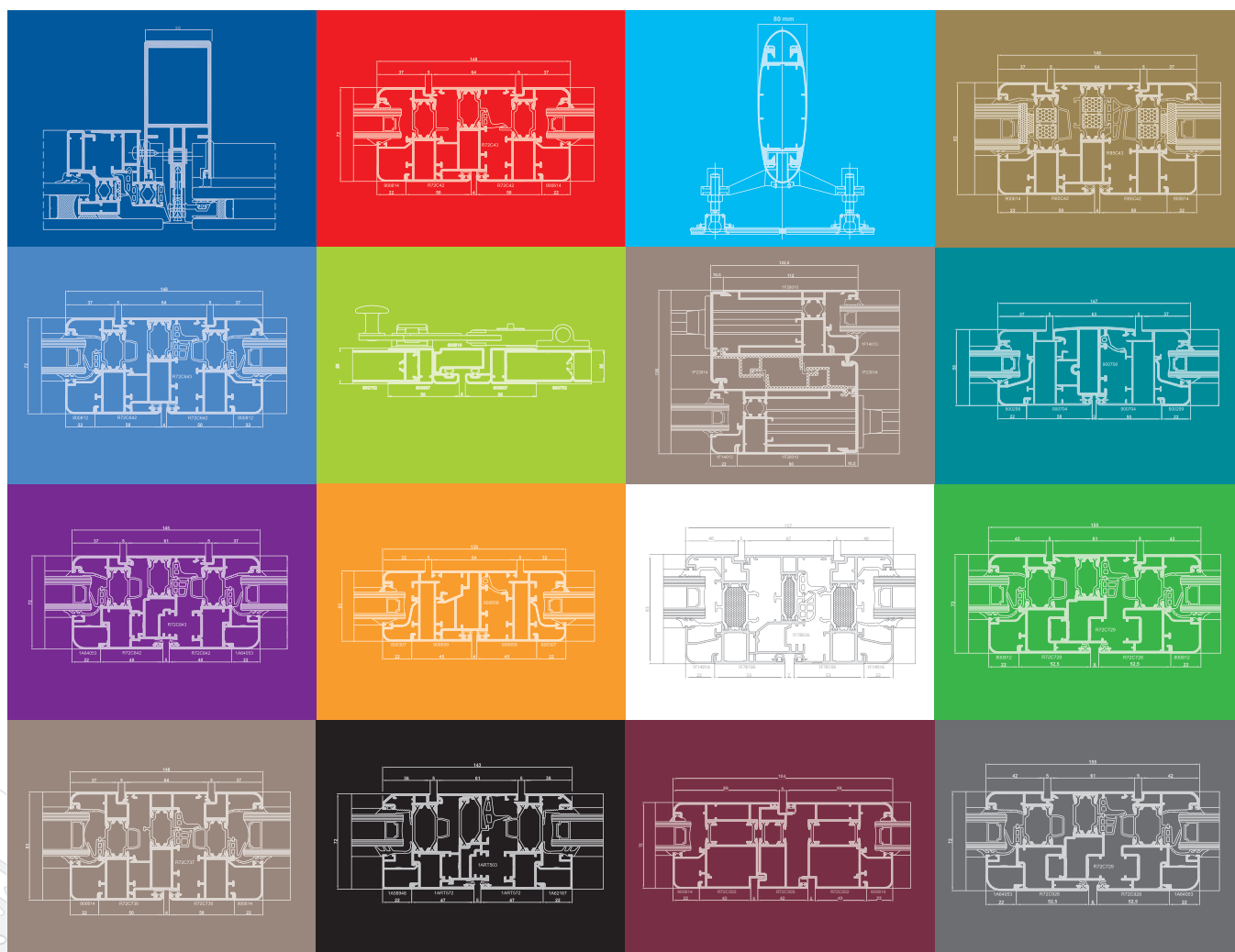

Scegliere con **serenità**

sapa:

Creiamo il futuro

sapa:

Original Systems®

... scegliere con serenità

Original Systems Sapa non è soltanto un profilo in alluminio: è una soluzione completa per tutti gli attori della filiera, con l'obiettivo di fornire il miglior prodotto, col più alto valore aggiunto, dalla bauxite al serramento.

L'assistenza tecnica pre e post vendita, i certificati delle prestazioni dei serramenti, la formazione della Scuola del Serramento di Bareggio (MI), i software di calcolo, le soluzioni Autocad, gli opuscoli tecnici, i cataloghi, la comunicazione ed una capillare e competente Rete di Distribuzione Original Systems Sapa vi danno la serenità di aver fatto la scelta migliore.

soluzioni Original Systems®

Sistema R^{TT}

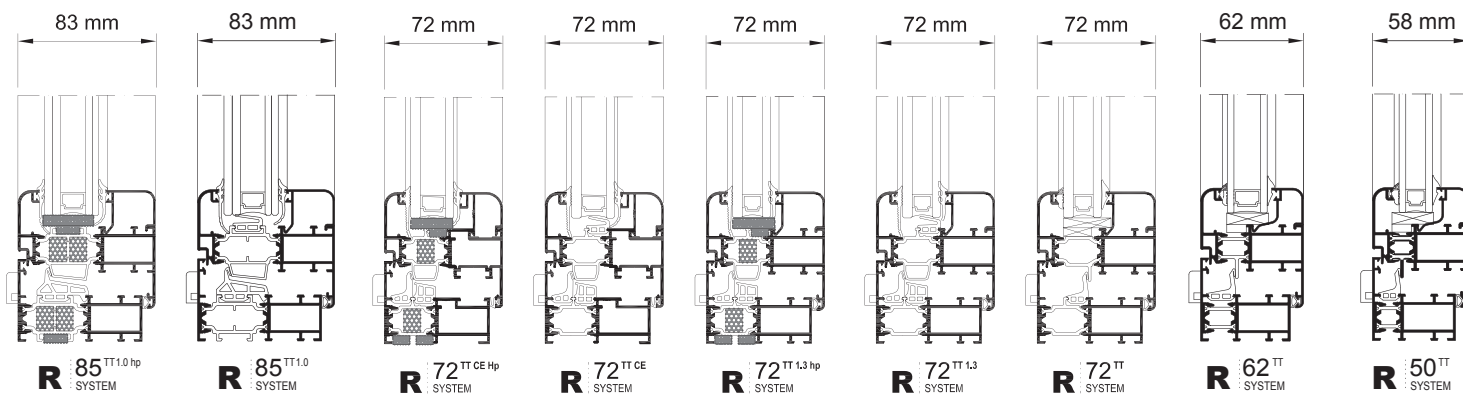

Alfil *next*

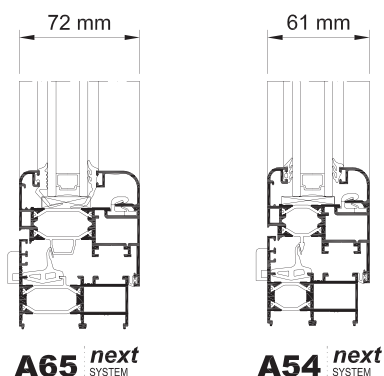

Sistema R

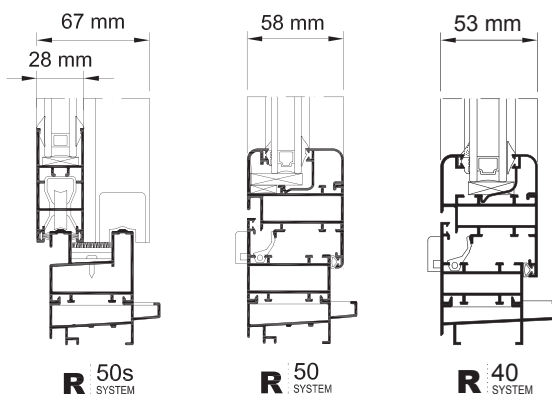

Mr. Hide SYSTEM

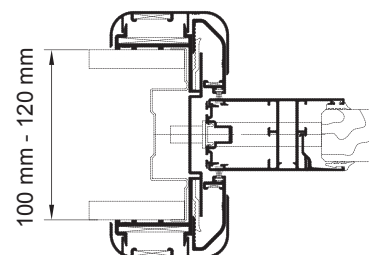

Teknowindow Battente

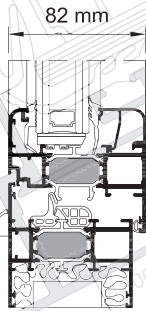

WIN 82su^{TT}
SYSTEM

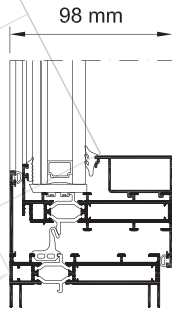

WIN 70^{TT}
SYSTEM

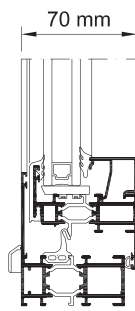

WIN 70^{TT}
SYSTEM

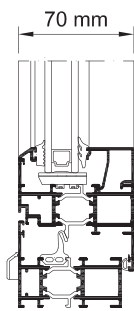

WIN 70^{TT}
SYSTEM

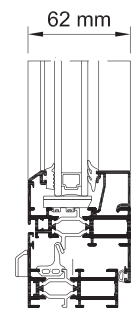

WIN 62^{TT}
SYSTEM

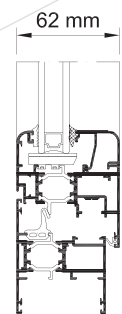

WIN 62^{PTT}
SYSTEM

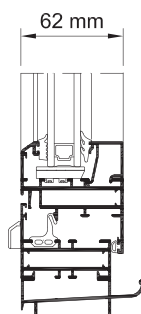

WIN 62
SYSTEM

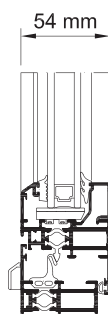

WIN 54^{TT}
SYSTEM

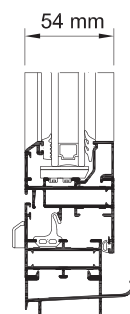

WIN 54
SYSTEM

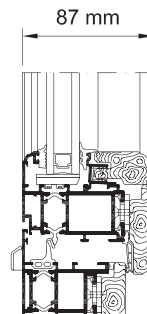

WIN LIGNUM^{TT}
SYSTEM

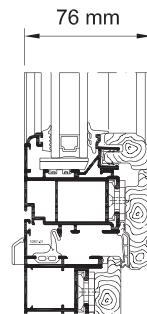

WIN LIGNUM
SYSTEM

Teknowindow Scorrevole

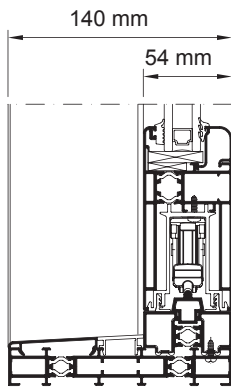

WIN 140sa^{TT}
SYSTEM

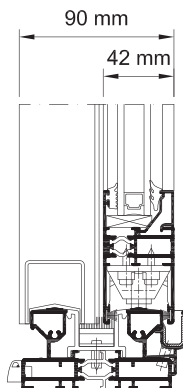

WIN 90s^{TT}
SYSTEM

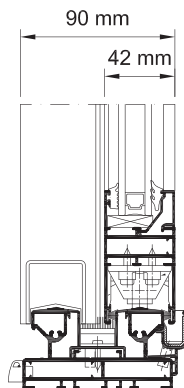

WIN 90s
SYSTEM

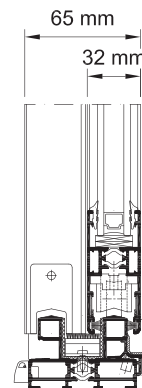

WIN 65s^{TT}
SYSTEM

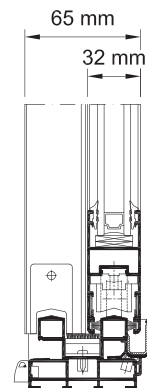

WIN 65s
SYSTEM

Sistemi Oscuranti

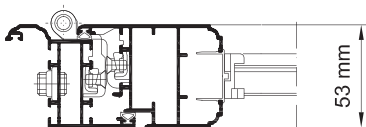

Persiane

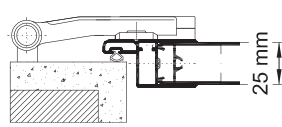

Scurone Venezia

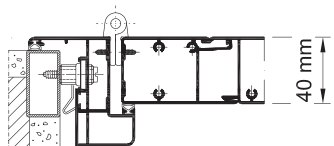

Scurone Padova

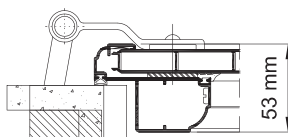

Scurone Romagna

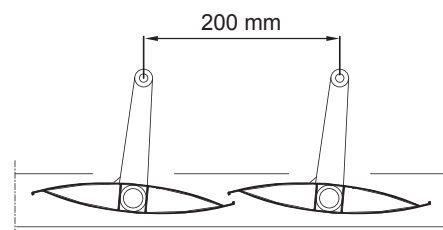

Frangisole

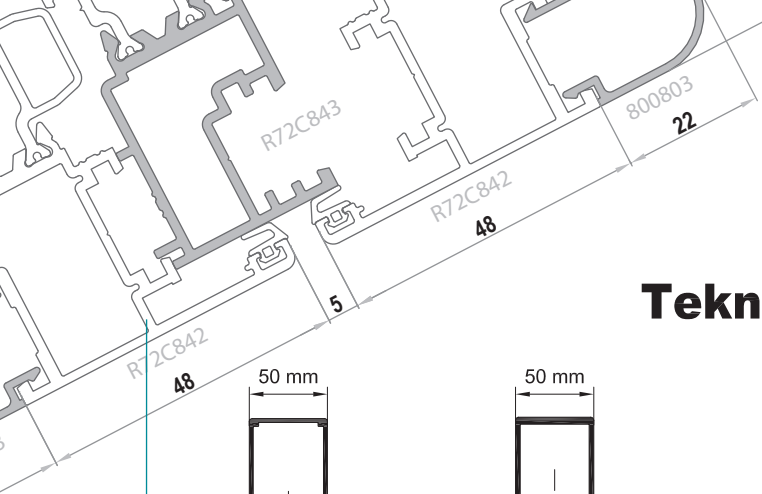

Teknowall

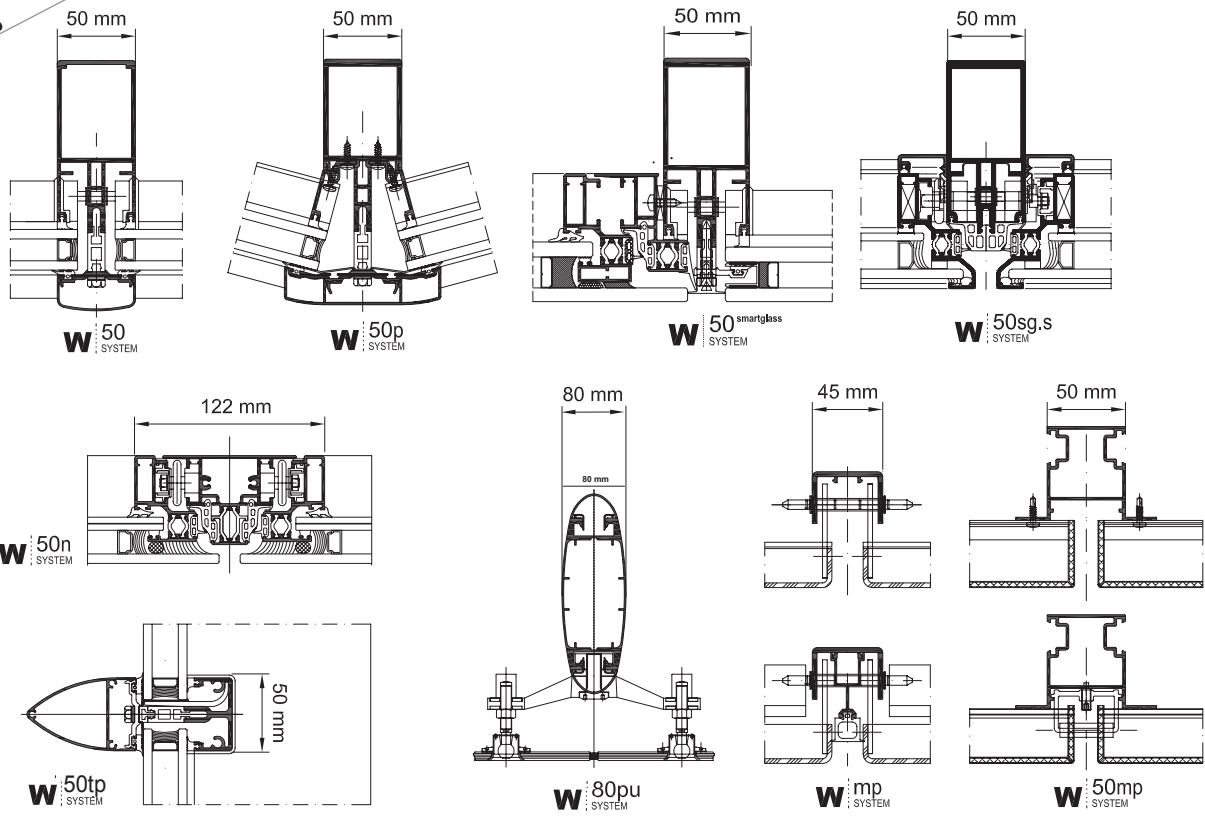

Portoni

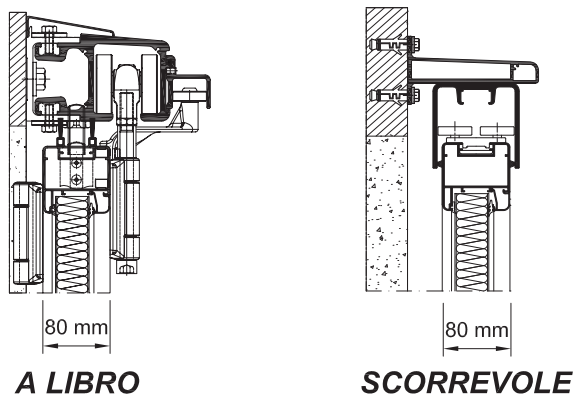

Veranda a Libro

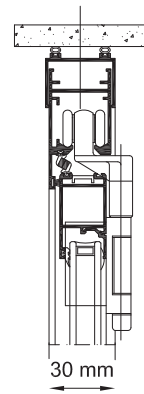

GR 14 SYSTEM

plus® SYSTEM

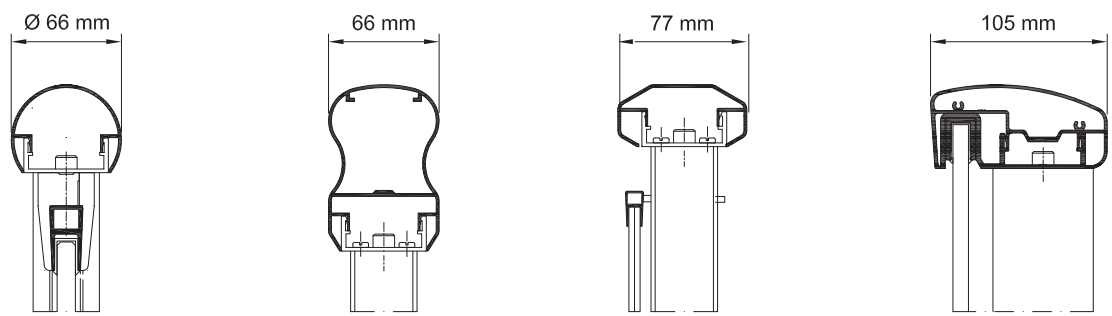

RINGHIERE E BALCONI

I Profilati:

Estrusi in lega di alluminio primario da lavorazione plastica EN AW 6060 UNI-EN 573-3 sottoposti ad un processo di trattamento termico applicato secondo Normativa UNI EN 755-2 (bonifica con tempra in aria alla pressa, seguita da invecchiamento artificiale) per ottenere lo stato T5.
Per dettagli tecnici vedere pagina F1-65s-A.04

Trattamenti superficiali:

I trattamenti superficiali di ossidazione anodica, elettrocolorazione e di verniciatura eseguiti negli impianti di proprietà Sapa, sono nel rispetto di quanto previsto dalle normative richieste dai marchi Qualanod (per ossidazione) e Qualicoat (per la verniciatura).

Vetratura:

La scelta ed il tipo di vetro sarà in funzione del suo campo di impiego, per il montaggio attenersi scrupolosamente alle prescrizioni dei produttori.

Il Sistema consente l'inserimento di vetri aventi spessori da 4 a 20 mm per Win 65; da 4 a 29 mm per Win 90; da 16 a 25 per Win 90 vetro ad infilare; da 20 a 38 mm per Win 140sa.

Le guarnizioni di tenuta vetro sono in EPDM ed inseribili e sostituibili a serramento assemblato, studiate in vari spessori che, interpolati nel modo idoneo, garantiscono un'adeguata compressione sulla lastra di vetro. La tassellatura sarà effettuata con appositi tasselli di regolazione e spessoramento aventi posizioni nel serramento ideali e rinforzate. Solo la completa e totale osservanza della tecnica di vetratura potrà garantire uno scatto vincolante e sicuro del fermavetro e la garanzia di durata agli sforzi di normale utenza.

Calcolo dimensioni massime serramenti:

Nel definire le misure massime dei diversi tipi di serramento, si devono considerare oltre agli elementi costruttivi dell'infilso (sezione dei profilati e loro campi d'impiego, tipo di attacco al muro, spessore e tipo del vetro), le caratteristiche di utilizzo, nonché le varianti metereologiche (esposizione dell'infilso, velocità dei venti agenti nella zona, altezza dal suolo alla quale sarà installato l'infilso, ecc.).

Consigliamo a tal fine la consultazione delle prescrizioni Uncsaal.

Attrezzature:

Le attrezzature raccomandate (Comall e Tekna) sono state appositamente progettate e realizzate per le particolari caratteristiche del sistema e per l'applicazione specifica degli accessori a catalogo.

Peso dei profilati:

I pesi indicati sono puramente indicativi (peso teorico ricavato sullo spessore nominale del profilato); Le matrici di estrusione sono soggette ad un normale processo di usura che porta il peso dell'estruso da un minimo (matrice nuova) ad un massimo (matrice usurata al limite delle tolleranze dimensionali).

NB:

Il mancato impiego, anche parziale, dei prodotti originali, esclude qualsiasi possibilità di rivalsa nei confronti di Sapa.

Al fine di migliorare i propri prodotti, Sapa si riserva la facoltà di apportare, in qualsiasi momento e senza preavviso, le modifiche che riterrà opportuno.

I dati riportati su questo catalogo sono indicativi e non impegnativi.

The sections

These are extruded in primary aluminium alloy from EN AW 6060 UNI-EN 573-3 plastic manufacturing, subject to a thermal treatment, applied according to UNI EN 755-2 regulation (austempering through air tempering at the press, followed by artificial ageing) in order to achieve the T5 physical state.

For technical detail refer to page F1-65s-A.04

Surface treatments:

The surface treatments of anodization, electrocoloration and painting carried out in Sapa Italy plants, respect the regulations required by the brands: Qualanod (for anodization) and Qualicoat (for painting).

Glazing:

The choice and the type of glass will depend on its final use.

While assembling, it is essential to follow scrupulously the manufacturers' instructions.

With this System it is possible to insert glass with thickness of 4 to 20 mm for Win65; 4 to 29 mm Win 90; 16 to 25 mm for Win 90 glass insertion; 20 to 38 mm Win140sa.

The weatherstrips for the glass containment is in EPDM and is conceived in different thickness. If interpolated in the correct way, it assures a proper compression on the glass.

The plugging will be carried out through proper adjusting and shimming plugs, located in ideal and reinforced positions in the fastening. Only the full respect of the glazing technique will assure the proper functioning of the glass beading and will guarantee a long term resistance to the normal uses.

Window maximum dimensions:

During the definition of the maximum dimensions of the different sorts of windows, beside the structural elements of the frame (section, uses, juncture to the wall, thickness and sort of glass), the final use and the weather conditions (exposure of the window frame, speed of the wind in the area, distance from the ground where the frame will be installed, etc.) have to be taken into account.

To this purpose, we suggest to consult the Uncsaal regulations.

Equipment:

The recommended equipment (Comall and Tekna) has been planned and realized on purpose according to the particular characteristics of the system and to the specific application of the catalogue accessories.

Weight:

Any weight is shown just as an indication (theoretical weight made out of the nominal thickness of the section) The extrusion dies are subject to the natural wear and tear, therefore the section weight varies from a minimum when the dies is new, to a maximum weight when the die is at highest dimensional tolerances limits

NB:

Sapa declines any responsibility in case of use or partial use of non original products.

With the aim of improving it's products, Sapa reserves the possibility to make changes to this document at any moment and with no advise.

The data reported in this catalogue are indicative and not binding.

L'esecuzione del serramento dovrà prevedere tutte le operazioni necessarie per il buon funzionamento del "componente finestra" quali la sigillatura e il bloccaggio sicuro degli angoli, il fissaggio a muro adeguato e, necessariamente, l'utilizzo di accessori e guarnizioni originali. Le lavorazioni, proprio per garantire la giusta applicazione dei particolari, dovranno essere eseguite con attrezzature originali e collaudate sul sistema stesso. Gli scarichi dell'acqua e le asole di aerazione per vetri camera dovranno essere di dimensione e numero ottimale in funzione della dimensione e della tipologia del serramento.

The frame construction must include all the operations necessary for good working of the "window component", such as sealing and safe blocking of corners, suitable wall fixtures and the use of the original accessories and weatherstrips. In order to guarantee the correct application of the parts, works must be carried out with original equipment that has been tested on the system. The size and number of water drains and ventilation slots for double glazing must correspond to the size and type of window frame.

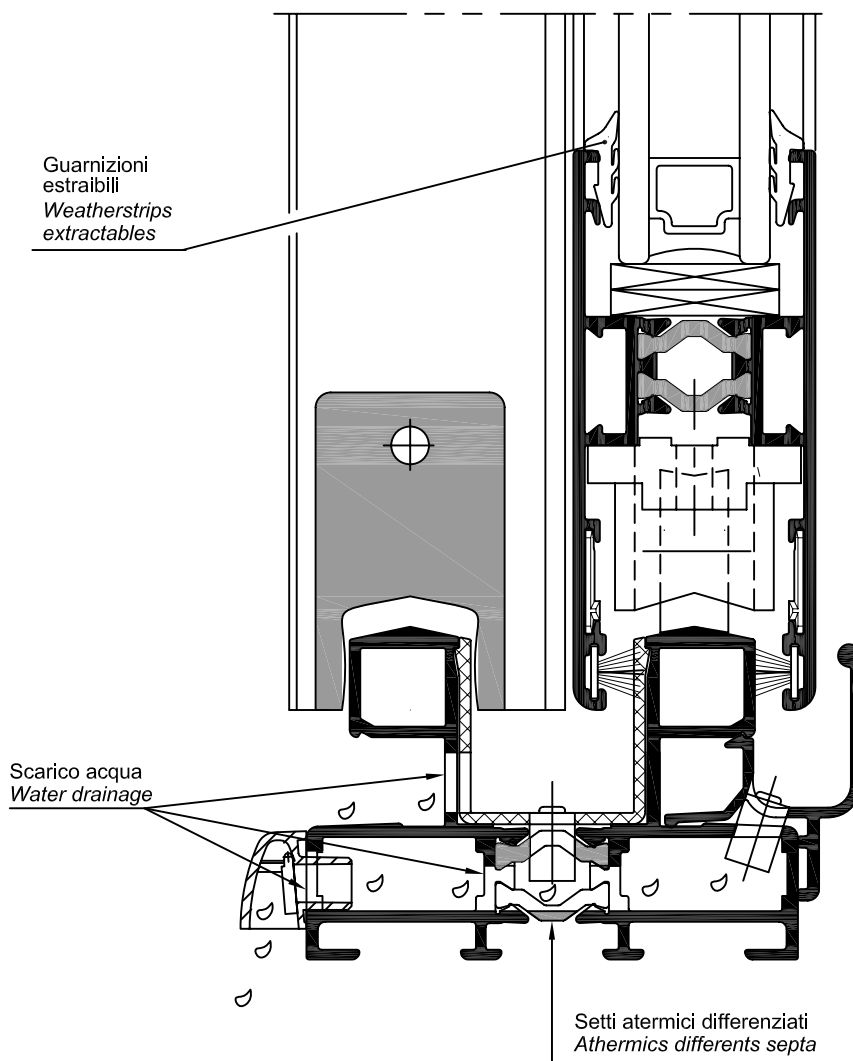

ACCESSORI DI ASSEMBLAGGIO E MOVIMENTO **ASSEMBLY AND MOVEMENT ACCESSORIES**

Gli accessori, brevettati, originali Teknowindow, sono frutto della collaborazione con le migliori aziende specializzate del settore. Sono realizzati con materiali equivalenti, per prestazioni e resistenza alla corrosione, a quelli dei telai; i perni sono in acciaio inox, le boccole ed i particolari di scorrimento sono realizzati in nylon rinforzato con bloccaggio del tipo a contrasto. Le squadrette di serraggio angoli, ad avvitare, a spinare ed a cianfrinare, sono realizzate con leghe di alluminio diverse secondo le esigenze del loro impiego.

The original patented Teknowindow accessories are the result of the collaboration with the best a specialized company in the sector.

They are constructed with materials of equivalent performance and corrosion resistance to the frames; the pins are in stainless steel, the bushes and sliding parts in reinforced nylon with blocking of the type with contrast.

The screwing, pinning and caulking corner joints are constructed with different aluminium alloys depending on their use

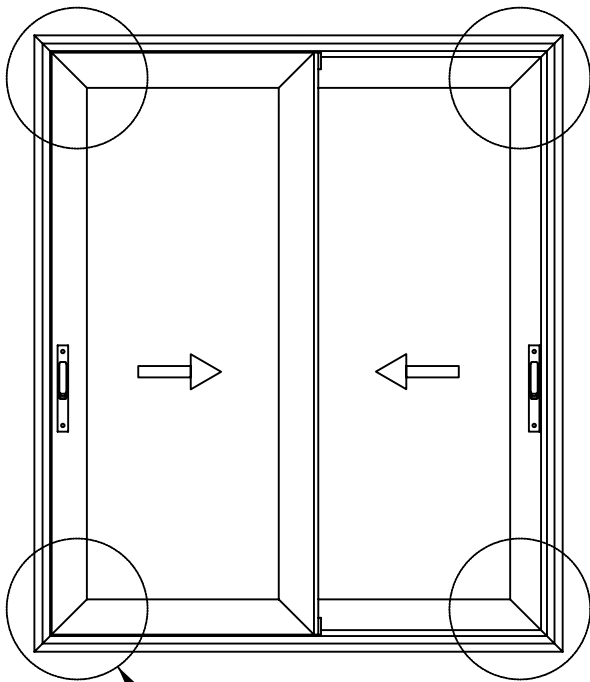

AVVERTENZE PER L'ASSEMBLAGGIO

1. Sigillare tutte le unioni tra profilati, nei tagli a 45° e nei collegamenti tra montanti e traversi
2. Sigillare in "A" per tutta la lunghezza del profilo
3. Le squadrette a cianfrinare e di allineamento battuta devono essere incollate con collante poliuretano monocomponente
4. Nei profilati a taglio termico, ove utilizzate squadrette a cianfrinare, devono essere prima incollate e poi cianfrinate. Cianfrinatura eseguibile anche con attrezzatura manuale (Art. M. 2001.00).
5. Le guarnizioni cingivetro interne ed esterne devono essere tagliate a 45° ed unite agli angoli con sigillante.
6. Le guarnizioni di battuta perimetrali devono essere tagliate a 45° ed unite sulla base degli angoli con collante cianoacrilico LOCTITE 406.

ASSEMBLY INSTRUCTIONS

1. Seal all the joints between sections, in the 45° cuts and in the connections between uprights and transoms.
2. Seal in position "A" for the all length of section
3. The caulking, levelling and rabbet alignment corner joints must be glued with monocomponent polyurethan adhesive
4. In the thermal break section, if you use crimping corner joints, these must be glued and caulked. Caulking may also be carried out by hand (Art. M.2001.00).
5. The internal and external glass-clamping weatherstrips must be cut at 45° and united to the corners with sealer
6. The perimetral rabbet weatherstrips must be cut at 45° and united on the base of the corners with LOCTITE 406

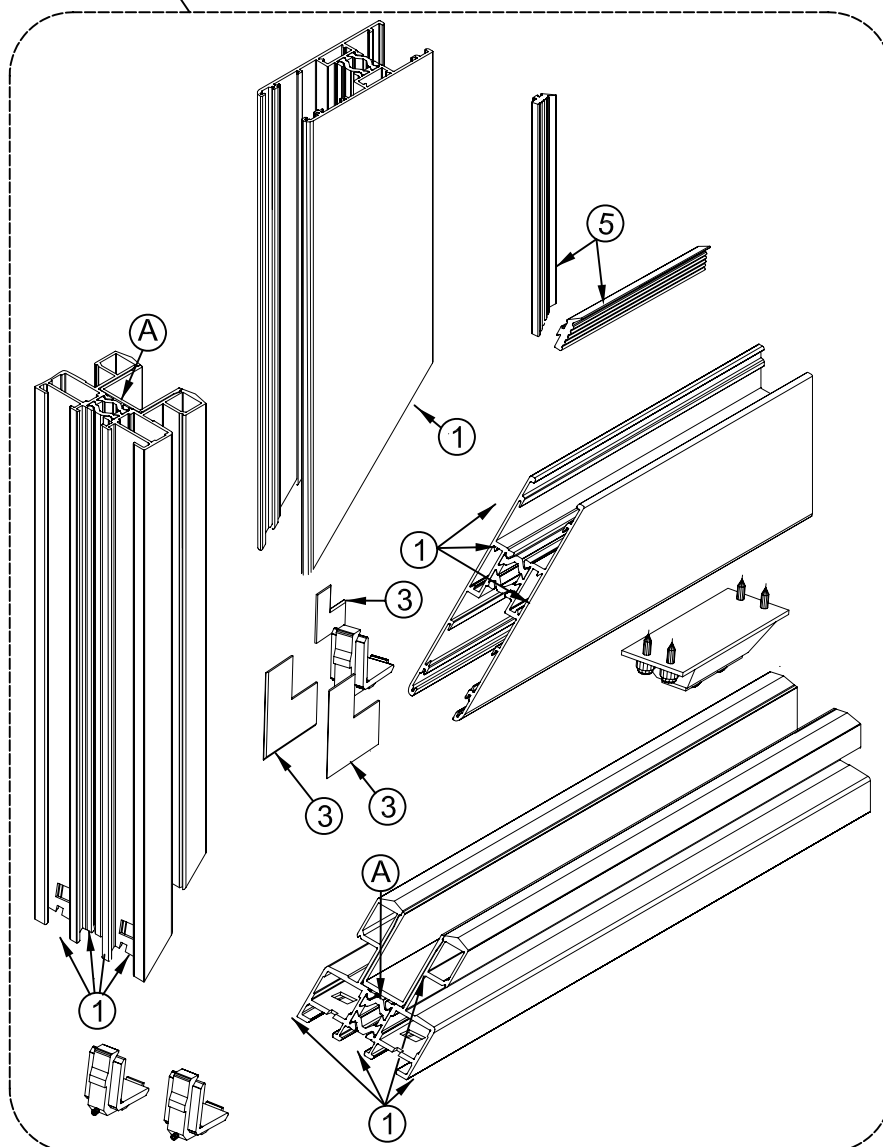

Una corretta posa in opera, evita spesso il decadimento delle prestazioni ottenute in laboratorio, curare in maniera appropriata la posa valorizza tutto il processo produttivo dalla progettazione all'installazione.

Fare una pulizia periodica con prodotti neutri riduce notevolmente i rischi di corrosione ed allunga sicuramente la vita dell'infisso. Per una corretta installazione, manutenzione e pulizia dei serramenti, Vi raccomandiamo di consultare le prescrizioni riportate sulle seguenti note tecniche UNCSAAL:

UX42 - "Guida alla posa in opera dei serramenti"

UX10 - "La pulizia delle superfici di serramenti e facciate continue"

A correct installation, often avoids the decay of the performances obtained in the laboratory. Taking appropriate care of the installation increases the value of the whole production process from the planning to the installation.

Cleaning periodically with neutral products reduces remarkably the corrosion risk and extends surely the life of the frame.

For a correct installation, maintenance and cleaning of the sections, we recommend you refer to the prescriptions quoted in the following technical notes of UNCSAAL UX42 and UX10



LEGHE IN ALLUMINIO DA BONIFICA - PROFILATI ESTRUSI
HEAT-TREATABLE ALUMINIUM ALLOYS - EXTRUSION SECTIONS

Leghe / Alloys		6060 UNI EN 573-3				
Composizione chimica normale / Normal chemical compos		Mg 0,4 Si 0,4 Fe 0,2				
Stato / State		0	T1	T5	T6	
Caratteristiche meccaniche <i>Mechanical Characteristics</i>	Carico di rottura a trazione <i>Ultimate tensite stress</i>	R _m N/mm ²	140 Max	120	185	205
	Carico al limite di snervamento <i>Yield point</i>	R _p N/mm ²	80 Max	50	145	165
	Allungamento <i>Elongation</i>	A %	20	16	11	10
Caratteristiche fisiche <i>Physical Characteristics</i>	Peso specifico <i>Specific weight</i>	Kg/dm ³	2,70			
	Conduttività termica a 20°C <i>Heat conductivity at 20°C</i>	W/ (cm °K)	≈ 2,09		≈ 1,75	
	Resistività elettrica a 20°C <i>Electrical resistivity at 20°C</i>	μΩ ·cm	≈ 3,14		≈ 3,25	
	Coef. di dilatazione termica lineare da 20° a 200°C <i>Linear thermal expansion coefficient from 20° to 200° C</i>		24 ·10 ⁻⁶ K ⁻¹			

PRESTAZIONI AGLI AGENTI ATMOSFERICI
ATMOSPHERIC AGENTS PERFORMANCES

WIN 65s^{TT}
 SYSTEM

WIN 65s
 SYSTEM

Per garantire il massimo delle prestazioni in funzionalità e durata, il sistema TEKNOWINDOW è stato sottoposto ai collaudi prescritti dalle vigenti Normative europee ottenendo ottimi risultati

To guarantee the maximum functionality and wear, TEKNOWINDOW system has been tested according to the running european norms.

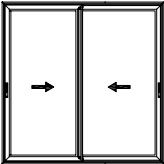
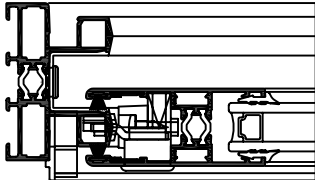
CERTIFICATI		CERTIFICATES					
Sistema System	Tipologia Windows and doors	Dimensioni Dimensions L x H mm	Risultati prove Test values			Sezioni Cross section	Laboratorio Certificato n° Laboratory Certificate nr.
			Aria Air	Acqua Water	Vento Wind		
WIN 65s ^{TT} SYSTEM		1600 x 2200	Cl.3	7A	B4		ISTEDIL 1595/2006-C

Tecnicamente, viene definito "a taglio termico" un profilato metallico che, una volta impiegato nella costruzione di un infisso, presenti il lato rivolto all'interno nettamente diviso dal lato esposto all'esterno per impedire lo scambio termico. Le due parti della sezione devono essere perciò separate da un materiale diverso, con bassi valori di conducibilità termica.

Il taglio termico del sistema Teknowindow, realizzato con barrette in poliammide rinforzato, si colloca su bassi valori di trasmittanza termica, in linea con i sistemi a taglio termico più avanzati.

Per evitare slittamenti dei vari componenti del profilato a taglio termico è prescritta la pre-zigrinatura dei particolari di bloccaggio prima dell'operazione meccanica di accoppiamento.

A metal section which, when used in the construction of a frame, has the side facing inwards clearly divided from that facing outwards to prevent heat exchange is technically defined as "thermal break". The two parts of the section must therefore be separated by a different material, with low conductivity values.

The thermal break of the Teknowindow system, produced with reinforced polyamide bars, is placed on low Uf values (heat transmission coefficient), in line with the most advanced thermal break systems.

To prevent the components of the thermal break section from slipping, it is advisable to pre-knurl the blocking parts before carrying out the mechanical coupling operation.

Tutti i profilati a taglio termico venduti da Sapa sono sempre riconoscibili.

Il marchio, impresso a laser è stato previsto per essere sempre visibile nel profilato assemblato come dalla figura sottostante

All thermal break sections are always recognizable. The laser impressed brand is always visible on the assembled sections as you can see in the picture here under



Sapa non risponde di eventuali difetti imputabili ad accoppiamenti non eseguiti nei propri stabilimenti e/o dovuti all'utilizzo di macchine non idonee e/o mal regolate.

Sapa will not be responsible for any incidental defects due to couplings which have not been carried out in its own premises and/or due to the use of not proper and/or not well-regulated machines.

I valori di trasmittanza termica U_f sotto riportati sono i risultati di calcolo eseguiti dall'Istituto ITC-CNR di San Giuliano Milanese, secondo la normativa UNI EN ISO 10077-2

The thermal performance values U_f hereunder reported are calculation results from the Institute ITC-CNR of San Giuliano Milanese, in accordance with the norm UNI EN ISO 10077-2

Nella porzione di tubolarità delimitata dalle barrette del taglio termico si assume:

- Il valore pari a 0,90 per l'emissività dell'alluminio verniciato
- Il valore pari a 0,30 per l'emissività dell'alluminio non verniciato

The equivalent thermal conductivity of the cavity between aluminium and polyamid bars is:

- 0,90 If the aluminium is painted
- 0,30 If the aluminium is mill finish

CERTIFICATI

CERTIFICATES

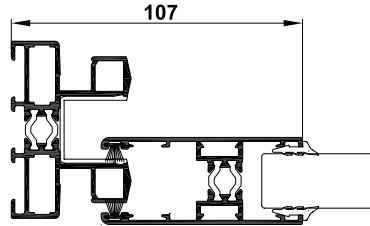
Sistema System	Sezioni Cross section	Risultati calcolo Calculus values		Laboratorio Certificato n° Laboratory Certificate nr.
		$U_f = W/m^2 \cdot ^\circ K$		
		$\epsilon = 0,9$	$\epsilon = 0,3$	
WIN 65s ^{TT} SYSTEM		4,56	4,51	ITC 4724/RP/08

"Valido solo per il territorio ITALIANO"

"Applicable only for Italy"

Requisiti della prestazione energetica degli edifici

Decreto legislativo 29 dicembre 2006, n. 311

Disposizioni correttive ed integrative al decreto legislativo 19 agosto 2005, n. 192, recante attuazione alla direttiva 2002/91/CE, relativa al rendimento energetico nell'edilizia.

Stabilisce i valori massimi della trasmittanza termica dei vetri e delle chiusure trasparenti comprensive di vetri e profilati metallici.

Tabella 4a Valori limite della trasmittanza termica U delle chiusure trasparenti comprensive degli infissi espressa in W/m ² K			
Zona climatica	Dall' 1 gennaio 2006 U (W/m ² K)	Dall' 1 gennaio 2008 U (W/m ² K)	Dall' 1 gennaio 2010 U (W/m ² K)
A	5,5	5,0	4,6
B	4,0	3,6	3,0
C	3,3	3,0	2,6
D	3,1	2,8	2,4
E	2,8	2,4	2,2
F	2,4	2,2	2,0

Tabella 4b Valori limite della trasmittanza U dei vetri espressa in W/m ² K			
Zona climatica	Dall' 1 gennaio 2006 U (W/m ² K)	Dall' 1 gennaio 2008 U (W/m ² K)	Dall' 1 gennaio 2011 U (W/m ² K)
A	5,0	4,5	3,7
B	4,0	3,4	2,7
C	3,0	2,3	2,1
D	2,6	2,1	1,9
E	2,4	1,9	1,7
F	2,3	1,7	1,3

Il territorio nazionale è suddiviso nelle seguenti zone climatiche in funzione dei gradi-giorno, indipendentemente dalla ubicazione geografica:

Zona A - Comuni che presentano un numero di gradi-giorno non superiore a 600;

Zona B - Comuni che presentano un numero di gradi-giorno maggiore di 600 e non superiore a 900;

Zona C - Comuni che presentano un numero di gradi-giorno maggiore di 900 e non superiore a 1400;

Zona D - Comuni che presentano un numero di gradi-giorno maggiore di 1400 e non superiore a 2100;

Zona E - Comuni che presentano un numero di gradi-giorno maggiore di 2100 e non superiore a 3000;

Zona F - Comuni che presentano un numero di gradi-giorno maggiore di 3000.

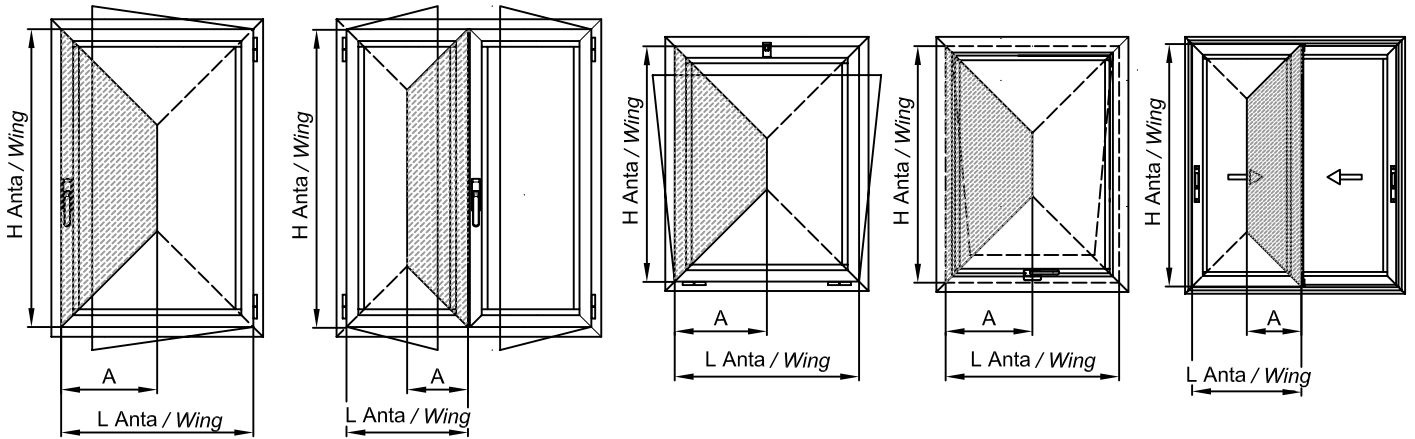

I grafici di seguito riportati sono stati ottenuti con la seguente formula:

The graphs below were created using the following formula:

$$J(\text{cm}^4) = \frac{q(\text{Kgf/cm}^2) \times H^4(\text{cm}) \times A(\text{cm})}{1920 \times E(\text{Kgf/cm}^2) \times f(\text{cm})} \times \left[25-40 \times \left(\frac{A}{H}\right)^2 + 16 \times \left(\frac{A}{H}\right)^4 \right]$$

Dove:

- Jx = Momento d'inerzia (cm⁴)
- q = Carico del vento (Kgf/cm²)
- H = Altezza anta (cm)
- A = Larghezza anta : 2 (cm)
- E = Modulo di elasticità (Kgf/cm²)
- f = Freccia (cm)

Were:

- Jx = Moment of inertia (cm⁴)
- q = Wind load (Kgf/cm²)
- H = Wing height (cm)
- A = Wing/2 width (cm)
- E = Coefficient of elasticity (Kgf/cm²)
- f = Camber (cm)

Essa è riferita al dimensionamento delle ante rispetto all'inerzia del profilato, per cui verificare sempre che il peso delle ante sia compatibile con la portata degli accessori impiegati, cerniere ecc. Inoltre verificare sempre che la freccia dei profilati sia compatibile con il vetro impiegato.

This refers to the size of the wings compared with the section inertia so always make sure the weight of the wings is compatible with the load of accessories hinge etc. used. Also always check that the section camber is suitable for the glass used.

CARICO DEL VENTO/ WIND LOAD : q= 50 Kgf/m²
 f max H/200 (Vetro in lastra singola/ Single pane glass)

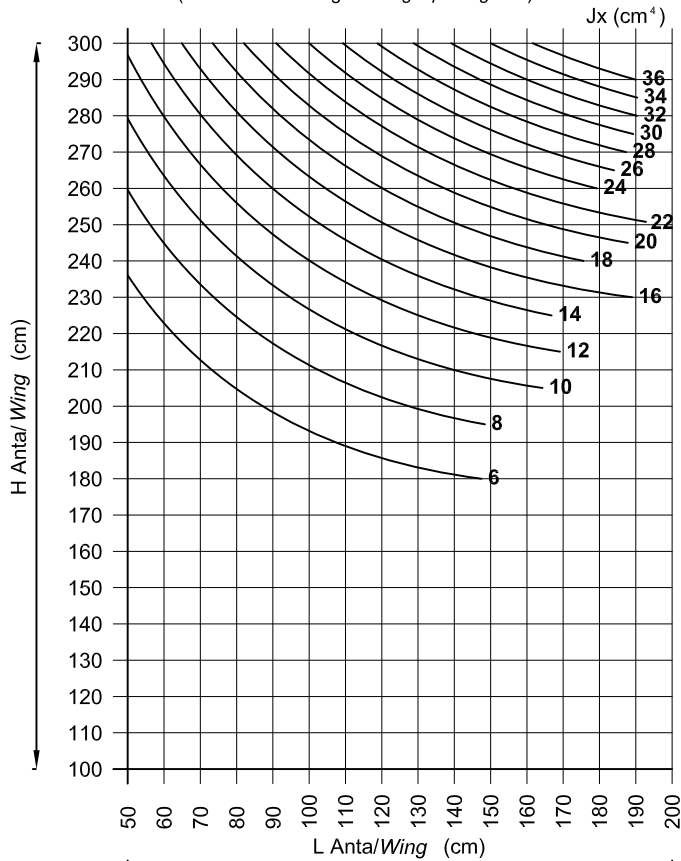

CARICO DEL VENTO/ WIND LOAD : q= 50 Kgf/m²
 f max H/300 (Vetro isolante / insulating glass)

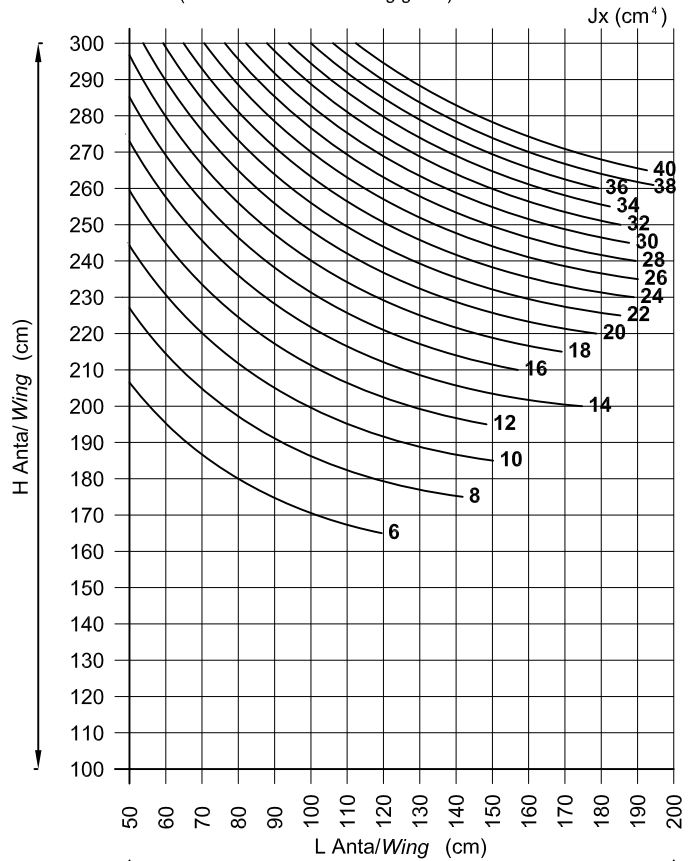

CARICO DEL VENTO/ WIND LOAD : $q=60 \text{ Kg/m}^2$
 f max H/200 (Vetro in lastra singola/ Single pane glass)

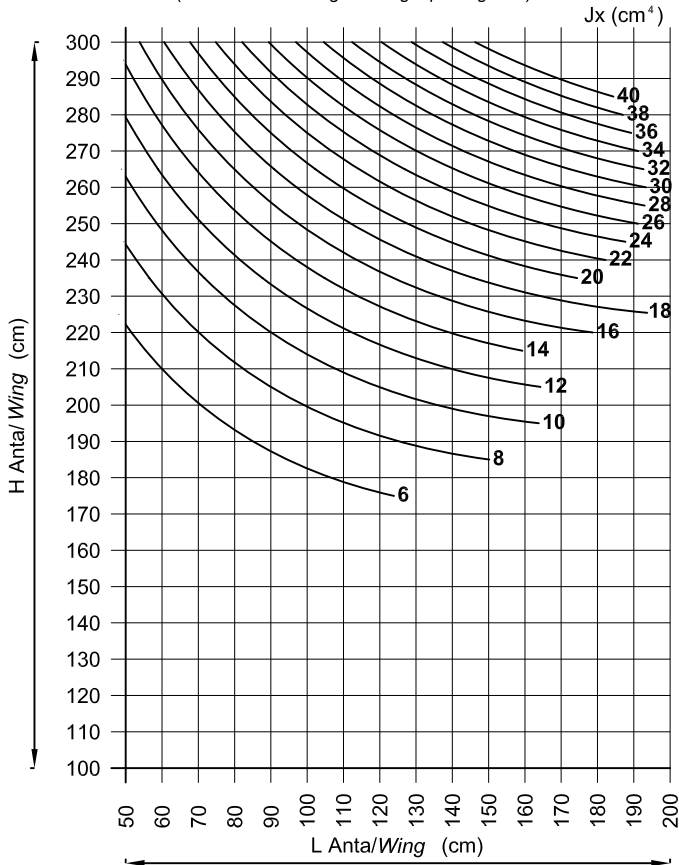

CARICO DEL VENTO/ WIND LOAD : $q=60 \text{ Kg/m}^2$
 f max H/300 (Vetro isolante / Insulating glass)

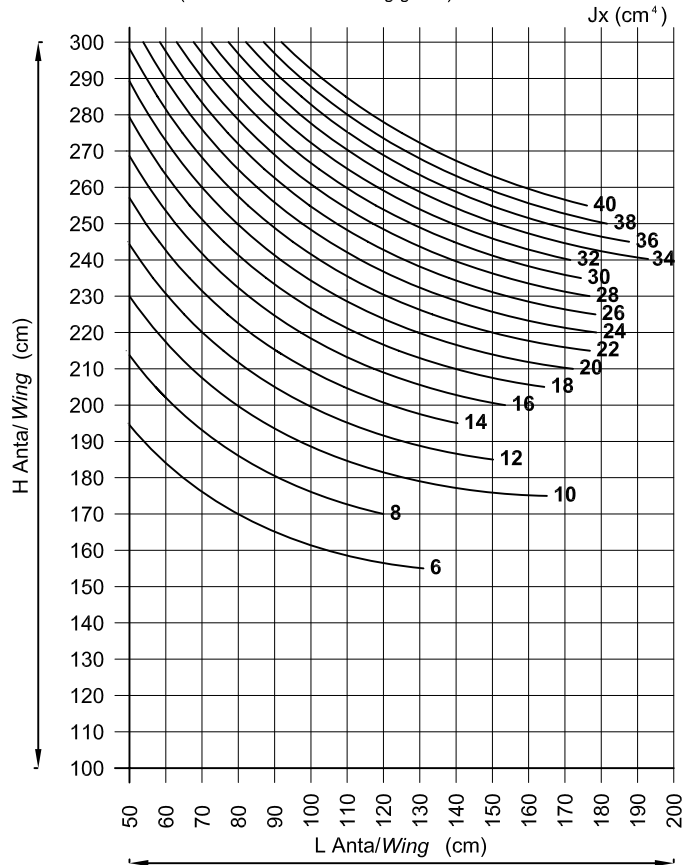

CARICO DEL VENTO/ WIND LOAD : $q=80 \text{ Kg/m}^2$
 f max H/200 (Vetro in lastra singola/ Single pane glass)

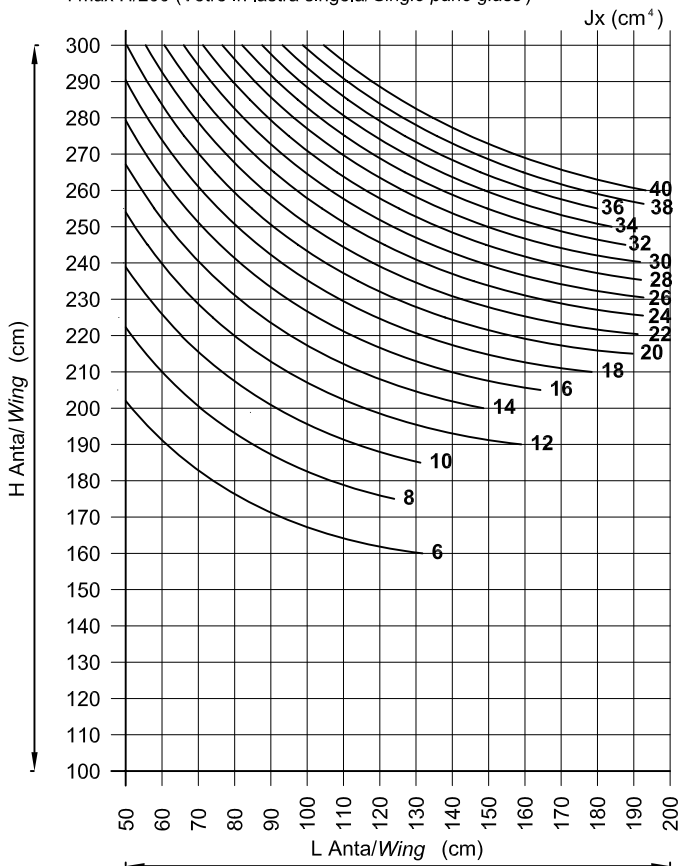

CARICO DEL VENTO/ WIND LOAD : $q=80 \text{ Kg/m}^2$
 f max H/300 (Vetro isolante / Insulating glass)

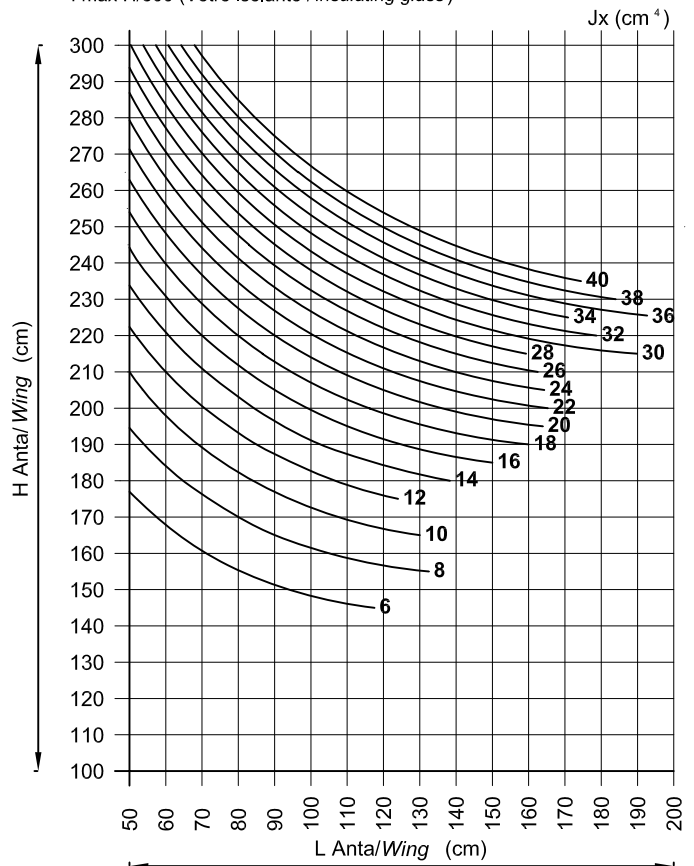

CARICO DEL VENTO/ WIND LOAD : $q = 100 \text{ Kg/m}^2$
 f max H/200 (Vetro in lastra singola/ Single pane glass)

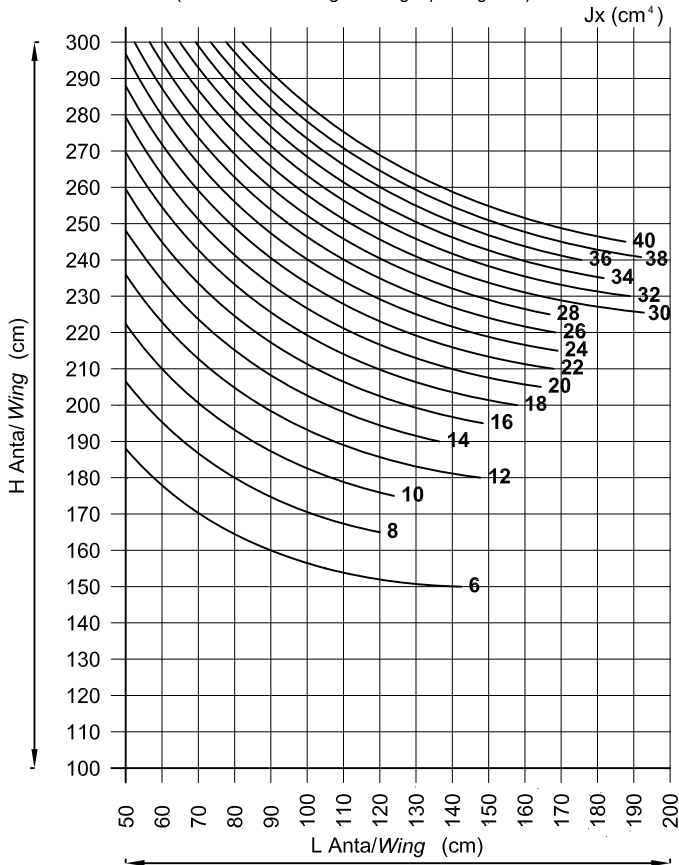

CARICO DEL VENTO/ WIND LOAD : $q = 100 \text{ Kg/m}^2$
 f max H/300 (Vetro isolante / Insulating glass)

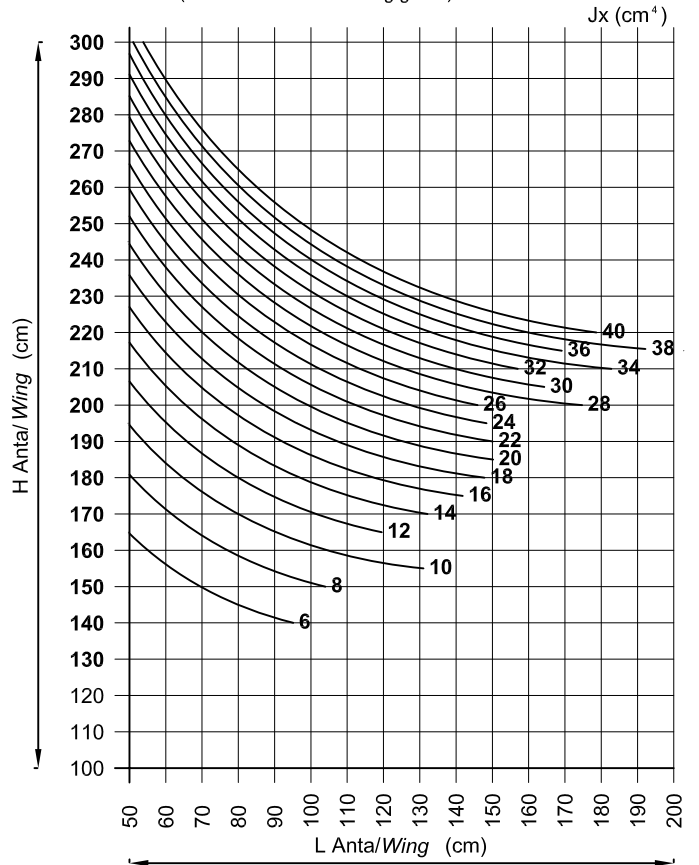

CARICO DEL VENTO/ WIND LOAD : $q = 120 \text{ Kg/m}^2$
 f max H/200 (Vetro in lastra singola/ Single pane glass)

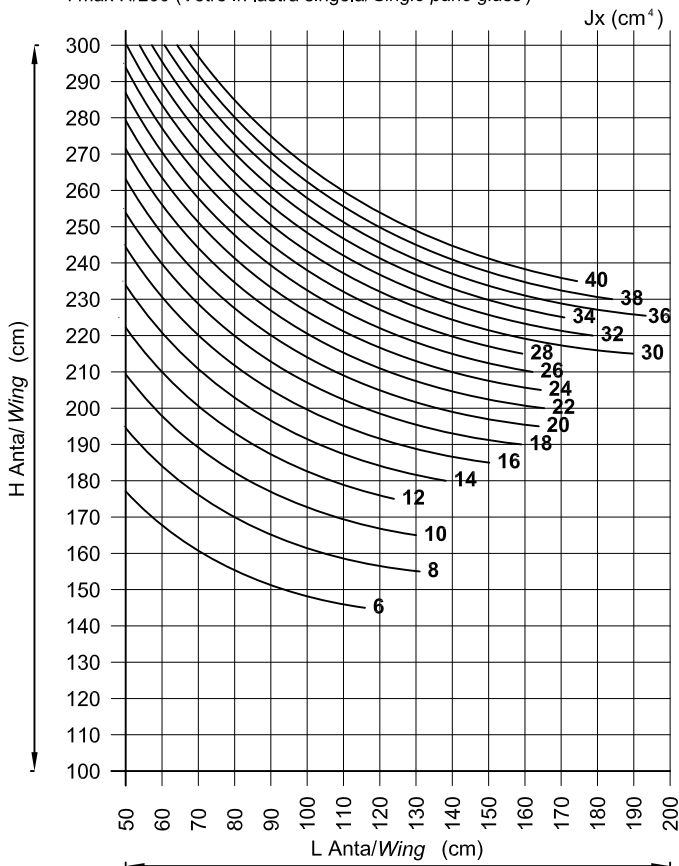

CARICO DEL VENTO/ WIND LOAD : $q = 120 \text{ Kg/m}^2$
 f max H/300 (Vetro isolante / Insulating glass)

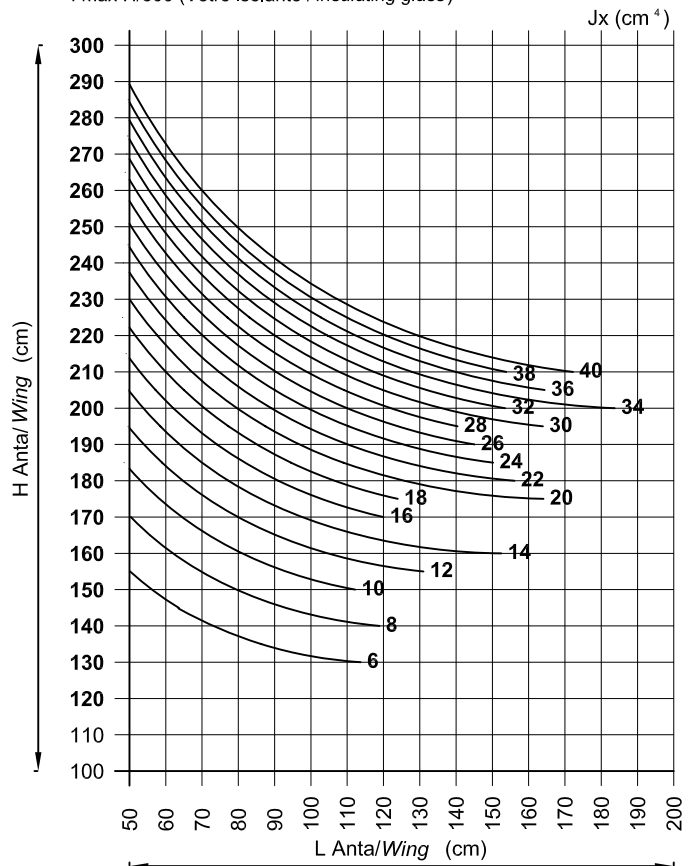

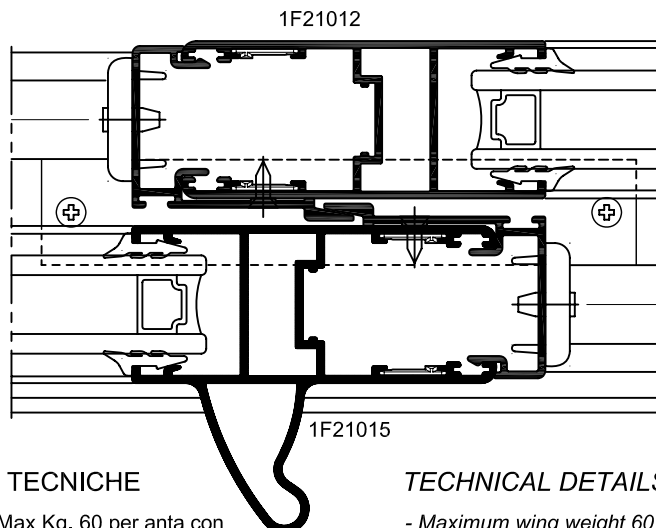
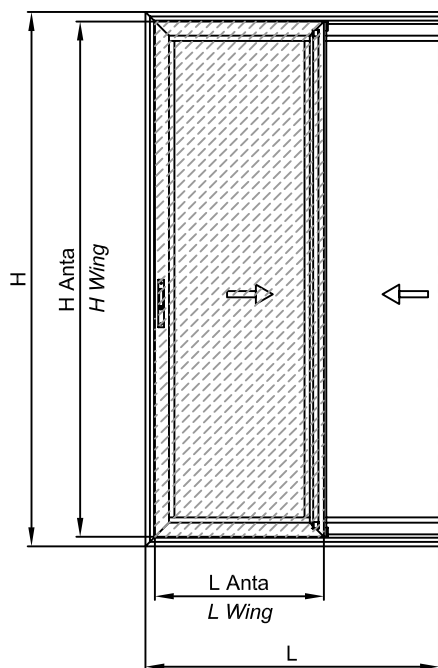

NOTE TECNICHE

- Peso Max Kg. 60 per anta con coppia di carrelli singoli
- Peso Max Kg 90 per anta con coppia di carrelli doppi
- Dimensioni La Max 1100 mm
- Dimensioni Ha Max 2100 mm
- Spessore vetro Max 14 mm (Con La x Ha Max 1100x2100)

N.B.: Lo spessore del vetro si riferisce allo spessore del materiale senza la camera d'aria.

TECHNICAL DETAILS

- Maximum wing weight 60 Kg with pair of single rollers
- Maximum wing weight 90 Kg with pair of double rollers
- Dimensions La Max 1100 mm
- Dimensions Ha Max 2100 mm
- Maximum glass thickness 14 mm (With La x Ha Max 1100x2100)

N.B.: The glass thickness refers to the material thickness without air chamber.

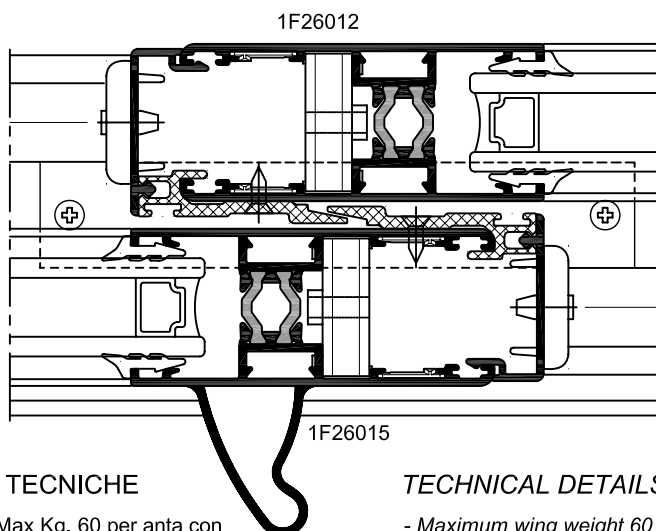
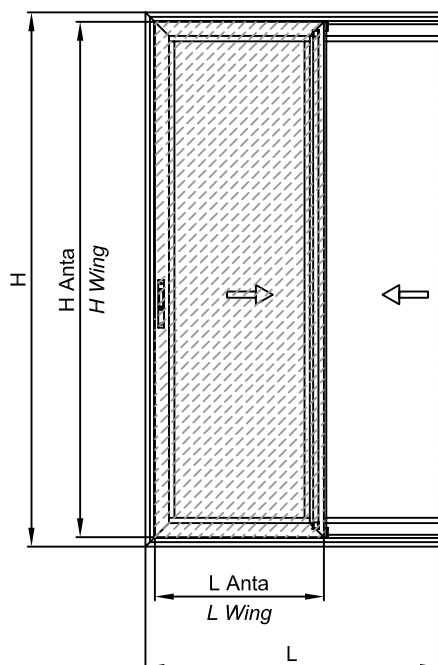

NOTE TECNICHE

- Peso Max Kg. 60 per anta con coppia di carrelli singoli
- Peso Max Kg 90 per anta con coppia di carrelli doppi
- Dimensioni La Max 1100 mm
- Dimensioni Ha Max 2000 mm
- Spessore vetro Max 16 mm (Con La x Ha Max 1100x2000)

N.B.: Lo spessore del vetro si riferisce allo spessore del materiale senza la camera d'aria.

TECHNICAL DETAILS

- Maximum wing weight 60 Kg with pair of single rollers
- Maximum wing weight 90 Kg with pair of double rollers
- Dimensions La Max 1100 mm
- Dimensions Ha Max 2000 mm
- Maximum glass thickness 16 mm (With La x Ha Max 1100x2000)

N.B.: The glass thickness refers to the material thickness without air chamber.

Gli accessori originali, progettati appositamente e specifici del Sistema TEKNOWINDOW, sono gli unici collaudati e garantiscono nel tempo la qualità del prodotto finale.

Only the original accessories in the TEKNOWINDOW System guarantee lasting quality of products

AVVERTENZA
NOTE

Per gli articoli indicati con ^(XXX) è possibile scegliere tra diversi produttori, tali articoli sono comunque forniti da Sapa. Le combinazioni possibili sono le seguenti:

For the articles indicating ^(XXX) there is the possibility to choose between different manufacturers although the goods will be supplied by Sapa. Here following the different combinations:

(BP) - Prodotte da BMP e PRODUCTA.

(BP) - Produced by BMP and PRODUCTA.

Per ordinare tali prodotti, è necessario inserire al termine del codice i seguenti numeri:

To order the articles you will need to indicate following numbers at the end of the code:

01 - Per BMP

01 - For manufacturer BMP

03 - Per PRODUCTA

03 - For manufacturer PRODUCTA

Esempio: Art. G.0004.EN^(BP) La scelta può essere fatta tra BMP (ordinando il codice G.0004.EN.01) e PRODUCTA (codice G.0004.EN.03).

Example: Article G.0004.EN^(BP) the choice may be between BMP (ordering art. G.0004.EN.01) and PRODUCTA (ordering art. G.0004.EN.03).

AVVERTENZA
NOTE

I prodotti descritti con il suffisso **.XX**, potranno essere forniti nelle finiture sotto indicate, sostituendo in sede di ordinazione l'indicazione **.XX** con i codici qui elencati:

*Products described with the suffix **.XX** can be supplied with the finished by replacing the **.XX** with the codes listed below when ordering:*

00 = Grezzo

00 = Raw

01 = Nero su materiali plastici

01 = Black on plastics

02 = Ossidato argento

02 = Anodized silver

06 = Ossidato bronzo

06 = Anodized bronze

15 = Elettro 5

15 = Electro 5

19 = Ossidato nero

19 = Anodized black

37 = Verniciato argento

37 = Painted silver

39 = Verniciato elettro 5

39 = Painted electro 5

41 = Verniciato bianco RAL 9010

41 = Painted white RAL 9010

43 = Verniciato avorio RAL 1013

43 = Painted ivory RAL 1013

50 = Verniciato nero RAL 9005

50 = Painted black RAL 9005

60 = Verniciato su commessa ***

*60 = Painted to order ****

*** Quantitativi e prezzi da concordare

**** Quantities and prices to be agreed*







Esempio:

La maniglia int./est. ad incasso art. 12203.xx, se ordinata come 12203.41 verrà fornita verniciata bianca RAL 9010

For example:







Insert internal/external handle code 12203.xx, will be supplied painted white RAL 9010 if ordered as 12203.41

SQUADRETTE
CORNER JOINTS

Articolo Item	Immagine Picture	Descrizione Description
10001.00		Squadretta allineamento battuta <i>Corner joint for alignment rabbet</i> In zama <i>Zamac</i>
10040.01		In nylon <i>Nylon</i>
10003.00		Squadretta esterna a cianfrinare <i>External corner joint to be crimped</i> 14 x 3 mm
10026.00		Squadretta ad avvitare <i>Corner joint to be screwed</i> 9,8 x 20,3 mm
12210.00		9,8 x 29,2 mm
12209.01		Squadretta in nylon per anta TT <i>Nylon corner joint for T.B. wing</i>
A.2900.AA		Squadretta in alluminio con viti <i>Stainless Corner joint with screws</i>

WIN 65s ^{TT} SYSTEM	WIN 65s SYSTEM			
■	■			
■	■			
■				
■	■			
	■			
■				
■				

ELEMENTI DI FISSAGGIO
FIXING ELEMENTS

10401.00		Basetta in alluminio per regolo mobile <i>Aluminium plate for adjustable fixing</i>
10402.01		Basetta in nylon per regolo mobile <i>Nylon plate for adjustable fixing</i>
10403.00		Basetta rettangolare in alluminio per regolo mobile <i>Rectangular aluminium plate for adjustable fixing</i>
10410.00		Grano per regolo mobile <i>Dowel for adjustable fixing</i> 16,5 mm
10411.00		23 mm
10425.00		Molla aggancio coprifili <i>Edge cover coupling spring</i>











■	■			
■	■			
■	■			
■	■			
■	■			
■	■			

TAPPI
PLUGS

10535.01		Tappo copriforo Ø 12 mm <i>Hole plug Ø mm 12</i>
----------	---	---

■	■			
---	---	--	--	--

ACCESSORI PER SCORREVOLI
SLIDING UNIT ACCESSORIES

Articolo Item	Immagine Picture	Descrizione Description
12002.00		Kit 4 carrelli singoli "carrera" 4 single roller kit "carrera"
12003.00		Kit 4 carrelli regolabili "carrera2" 4 adjustable double roller kit "carrera2"
12011.00		Kit tappi per due ante T.T. (da utilizzare solo con squadretta 10003.00) Two wings T.B. plugs kit (to be used only with corner joint 10003.00)
12012.00		Kit tappi per due ante T.T. (da utilizzare solo con squadretta 12209.01) Two wings T.B. plugs kit (to be used only with corner joint 12209.01)
12021.01		Tappi per gocciolatoio e raccoglicondensa (coppia) Drip channel and drip condensation plugs (pair)
12026.01		Fondino per montante centrale rinforzato Base for reinforced mullion
12027.00		Piastrina antisollevamento 3° e 4° anta 3th and 4th door non-lifting plate
12031.01		Kit valvola scarico acqua Water drain valve kit
12054.00		Kit di aggancio chiusura ad incasso Recessed clip-on locking kit
12201.xx		Maniglia interna ad incasso Inset internal handle for locking





WIN 65s ^{TT} SYSTEM	WIN 65s SYSTEM			
■	■			
■	■			
■	■			
■				
■	■			
■				
■	■			
■	■			
■	■			
■	■			

ACCESSORI PER SCORREVOLI
SLIDING UNIT ACCESSORIES

Articolo Item	Immagine Picture	Descrizione Description
12203.xx		Maniglia int./est. ad incasso <i>Inset internal/external handle for locking</i>
12204.xx		Maniglia int./est. ad incasso con serratura <i>Inset internal/external handle with cylinder lock</i>
12208.xx		Maniglia laterale di trascinamento in alluminio <i>Aluminium lateral drag handle</i>
M.0204.W5		Dima per foratura squadretta A.2900.AA <i>Drilling jig for corner joint</i>

WIN 65s ^{TT} SYSTEM	WIN 65s SYSTEM			
■	■			
■	■			
■	■			
■				

CHIUSURA MULTIPUNTO
MULTIPOINT CLOSING

A.5101.VA		Ferramenta base universale <i>Universal base fitting</i>
A.5102.VA		Elemento quarta chiusura <i>Element fourth closing</i>
A.5103.VA		Kit "UPGRADE" per adattare A.5104.VA oppure A.5105.VA al win 65 "freddo" <i>Kit "UPGRADE" to fix A.5104.VA or A.5105.VA with Win 65</i>
A.5104.VA		Kit accessori per chiusura con cremone <i>Kit accessories for cremone locking</i>

■	■			
■	■			
	■			
■				

CHIUSURA MULTIPUNTO
MULTIPOINT CLOSING

Articolo Item	Immagine Picture	Descrizione Description
A.5105.VA		KIT accessori per chiusura con paletto Europa, meccanismo bi-direzionale, doppia maniglia con chiave <i>Kit accessories for locking with Europe pole, double-way mechanism, double handle with key</i>
A.5108.VA		Paletto Europa senza chiave <i>Europe pole without key</i>
A.5109.VA		Paletto Europa con chiave <i>Europe pole with key</i>
A.5110.VA		Cassa manico Opera Vip senza chiave <i>Cover Opera Vip without key</i>
A.5111.VA		Cassa manico Opera Vip con chiave <i>Cover Opera Vip with key</i>
A.5112.VA		Doppia maniglia interna-esterna con chiave <i>Double handle internal-external with key</i>
A.5114.VA		Meccanismo bi-direzionale per martellina <i>Double-way mechanism internal</i>

WIN 65s ^{TT} SYSTEM	WIN 65s SYSTEM			
■				
■	■			
■	■			
■	■			
■	■			
■	■			
■	■			

SCHEMA DI IMPIEGO: SQUADRETTE, CAVALLOTTI, ALLINEAMENTO TRAVERSI
 USE SCHEME: CORNER JOINTS, "T" JOINTS, TRANSOM ALIGNMENT

WIN 65s
SYSTEM

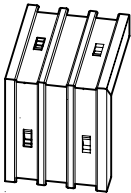
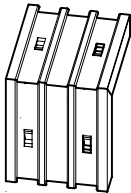
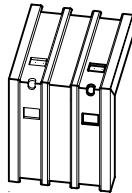
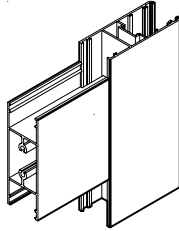
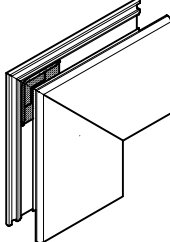
Profilato Section	Esterna a cianfrinare External crimping	Interna a cianfrinare Internal crimping	Avvitare Screwing	Cavallotto Allineamento trasversi "T" joint -Transom alignment	Allineamento su aletta di battuta Alignment on rabbet
					
1F21001	10008.00	10008.00	10026.00 (*)		
1F21002	10008.00	10008.00	10026.00 (*)		
1F21010	10008.00	10008.00	10026.00 (*)		10040.01 o/for 10001.00
1F21012			12210.00		10040.01 o/for 10001.00
1F21015			12210.00		10040.01 o/for 10001.00
1F21016		10011.00	10029.00		10040.01 o/for 10001.00
1F21018			12210.00		10040.01 o/for 10001.00

SCHEMA DI IMPIEGO: SQUADRETTE, CAVALLOTTI, ALLINEAMENTO TRAVERSI
 USE SCHEME: CORNER JOINTS, "T" JOINTS, TRANSOM ALIGNMENT

WIN 65s^{TT}
SYSTEM

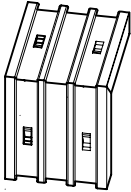
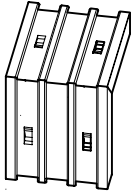
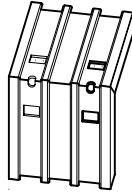
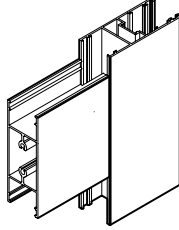
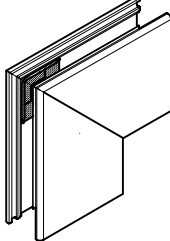
Profilato Section	Esterna a cianfrinare External crimping	Interna a cianfrinare Internal crimping	Avvitare Screwing	Cavallotto Allineamento trasversi "T" joint -Transom alignment	Allineamento su aletta di battuta Alignment on rabbet
					
1F26001	10008.00	10008.00	10026.00 (*)		10040.01 o/for 10001.00
1F26002	10008.00	10008.00	10026.00 (*)		10040.01 o/for 10001.00
1F26006	A.2900.AA	10008.00	10026.00		10040.01 o/for 10001.00
1F26010	10008.00	10008.00	10026.00		10040.01 o/for 10001.00
1F26012	10003.00	10003.00	12209.01		10040.01 o/for 10001.00
1F26015	10003.00	10003.00	12209.01		10040.01 o/for 10001.00
1F26016	10002.00 (**)	10008.00	10026.00		10040.01 o/for 10001.00
1F26018	10008.00	10008.00	10026.00 (*)		10040.01 o/for 10001.00

(*) Va inserita anche nel tubolare esterno

(*) To be insert also on external tubolar.







(**) La squadretta esterna non puo essere cianfrinata, deve essere incollata

(**) External corner joint can not be crimped, must be glued.

INSERIMENTO GUARNIZIONI, VETRI AD INFILARE
WEATHERSTRIPS AND GLASS INSERTION

WIN 65s^{TT}
 SYSTEM

WIN 65s
 SYSTEM

Articolo Item	Guarnizioni esterne External weatherstrips	Sezione Section	Articolo Item	Guarnizioni interne Internal weatherstrips	Sezione Section
10841.01	A = 3 mm		G.0004.EN	E = 3 mm	
10851.01	B = 5 mm		G.0005.EN	F = 4 mm	
			10861.01 10862.01	C = 5 mm	
			10871.01 10872.01	D = 6 mm	

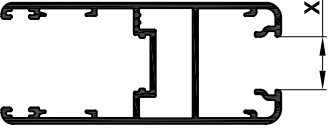
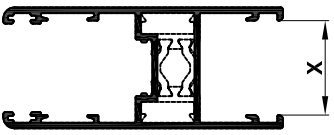



Spessore vetri WIN 65s SYSTEM	Glass thickness WIN 65s ^{TT} SYSTEM	Guarnizioni Weatherstrips	Dimensione Size	Sezione profilati Cross sections
4	-	D+C	X = 14 mm	 1F21018
5	-	D+F C+C		
6	-	D+E C+F		
7	-	C+E F+F		
8	-	E+F		
9	-	E+E		
14	14	D+D	X = 25 mm	 1F21012 - 1F26012
15	15	D+C		
16	16	D+F C+C		
17	17	D+E C+F		
18	18	C+E F+F		
19	19	E+F		
20	20	E+E		

N.B.: Le combinazioni sopra indicate sono state ottenute considerando le quote teoriche. Si consiglia sempre di verificare le tolleranze per applicare vetri, fermavetri e guarnizioni ottimali

The above combinations are based on theoretical dimensions. It is always best to check tolerance to apply correct glass, glass beadings and weatherstrips.

ELENCO PROFILATI
LIST OF SECTIONS

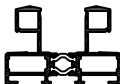
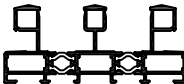
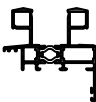
WIN 65s^{TT}
SYSTEM

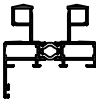
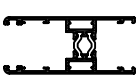
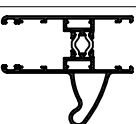
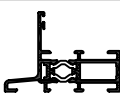
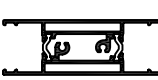
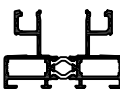
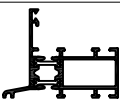
Profilato Section	Comp.ne Composition	Sezione Cross section	Peso Weight Kg/m	Perimetro Perimeter mm	Superficie in vista Exposed surface m ² /m	Jx cm ⁴	Wx cm ³	Jy cm ⁴	Wy cm ³
1F24006			0,150	145	0,010	-	-	-	-
1F24201			0,262	144	0,083	-	-	-	-
1F24203			0,213	114	0,088	-	-	-	-
1F26001	1F25016 A.0311.LN A.0311.LN 1F25016		1,460	382	0,174	9,16	3,68	20,18	6,21
1F26002	1F25016 A.0311.LN x 2 1F25020 A.0311.LN x 2 1F25016		2,251	548	0,188	13,45	5,38	74,36	14,50
1F26006	1F25032 A.0311.LN A.0311.LN 1F25023		1,566	495	0,183	12,29	3,14	20,63	5,65
1F26007	1F25001 A.0311.LN A.0311.LN 1F25001		0,698	207	0,042	2,79	1,55	0,75	0,64
1F26010	1F25023 A.0311.LN A.0311.LN 1F25016		1,559	441	0,200	12,76	3,30	23,72	6,83
1F26012	1F25015 A.0311.LN A.0311.LN 1F25015		1,168	412	0,162	6,95	4,34	14,81	3,84
1F26015	1F25015 A.0311.LN A.0311.LN 1F25017		1,492	466	0,211	16,44	4,13	16,04	3,97
1F26016	1F25022 A.0311.LN A.0311.LN 1F15002		1,110	361	0,087	3,64	1,15	12,70	3,59
1F26017	1F25019 A.0311.LN A.0311.LN 1F25019		1,676	372	0,192	7,77	5,01	28,06	6,24
1F26018	1F25038 A.0311.LN A.0311.LN 1F25038		1,426	429	0,152	7,62	3,08	20,16	6,20
R50C102	800786 A.0318.LN A.0318.LN 800588		1,173	404	0,098	5,75	1,71	13,77	4,11

ELENCO BARRETTE IN POLIAMMIDE
LIST OF REINFORCED POLYAMIDE BARS

WIN 65s^{TT}
SYSTEM

Codice Code	Sezione Cross section	Peso Weight Kg/m
A.0311.LN		0,045

Scala 1:1
Scale 1:1



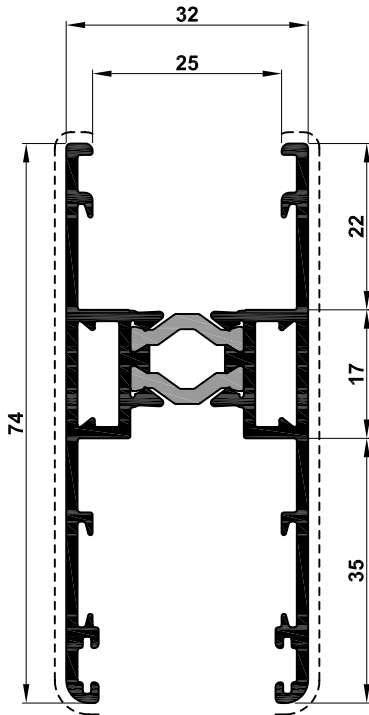

1F26012

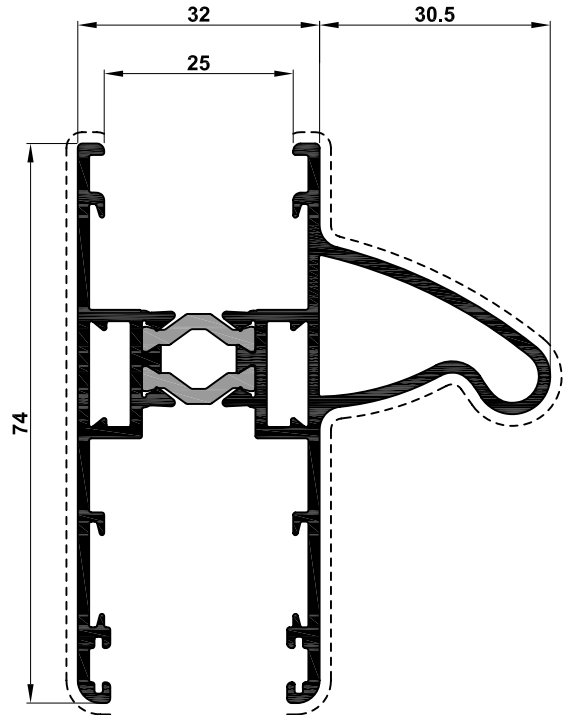

1F26015

RIPORTO CENTRALE
CENTRAL FILLING

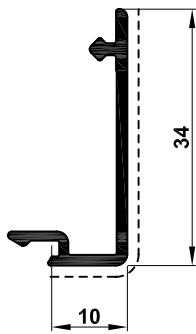

1F24203

POLIAMMIDE
POLYAMIDE

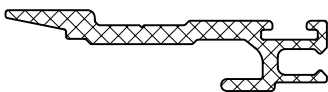

G.0308.LN

RIPORTE 3° E 4° ANTA
3° - 4° WING FILLING

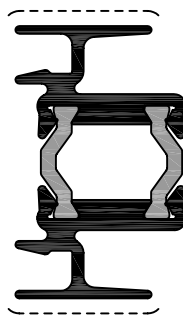

1F26007

FASCIA
BAND

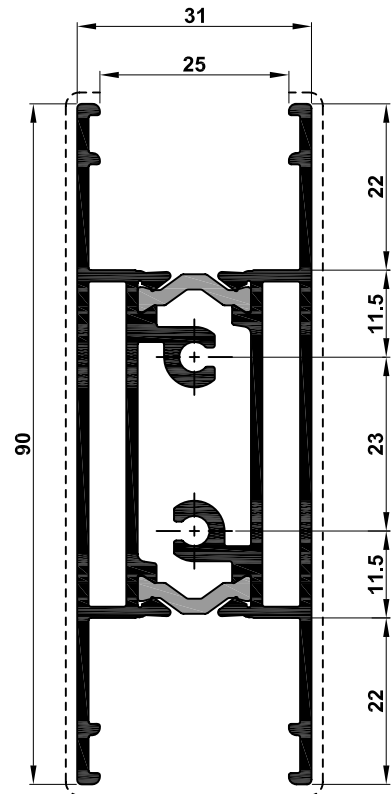

1F26017

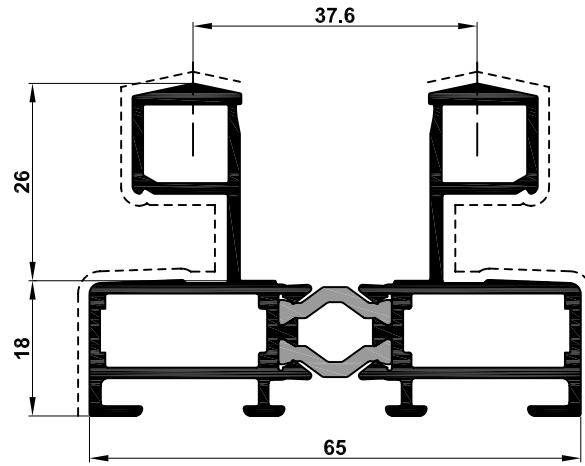

1F26001

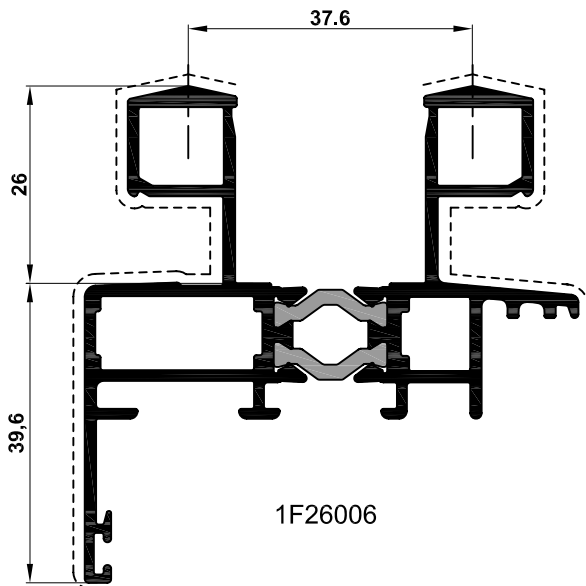

1F26006

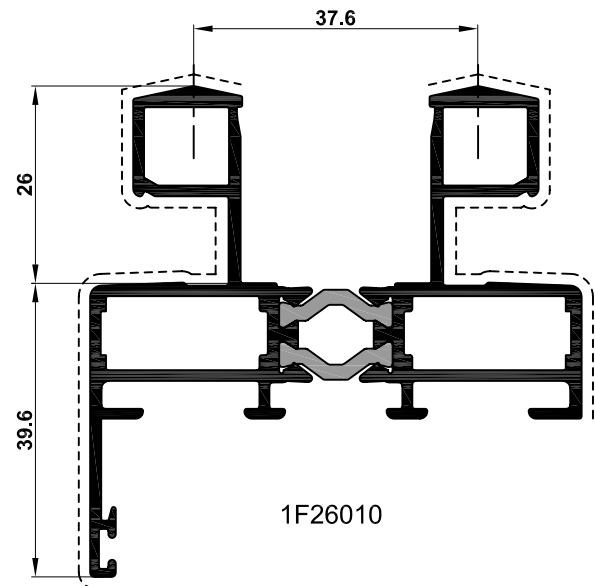

1F26010

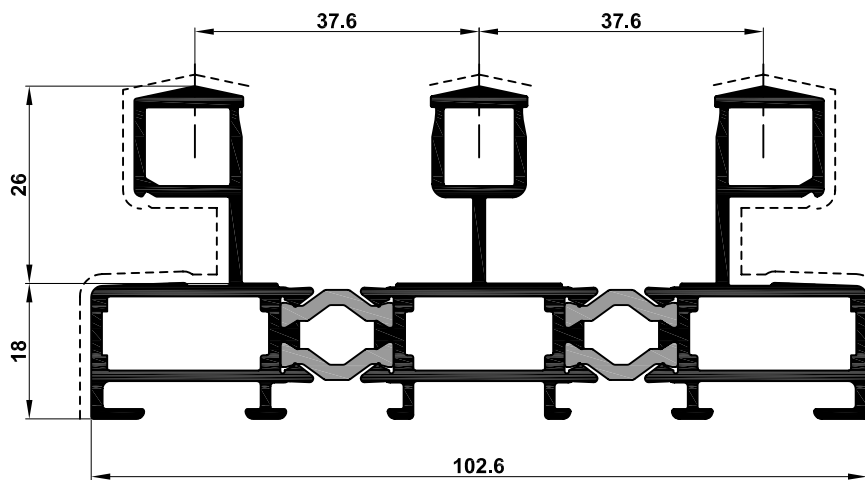

1F26002

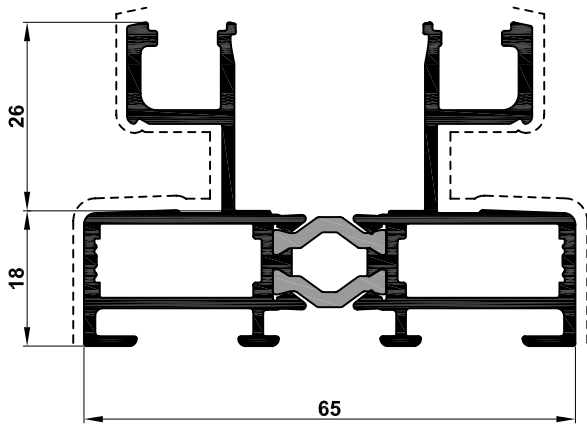

1F26018

RIPORTO PER TELAIO 1F26018
FILLING FOR FRAME 1F26018



1F24006

VARI
DIFFERENT SECTIONS

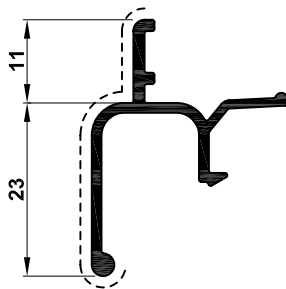

1F24201

RIPORTO IN POLIAMMIDE
FILLING IN RIGID POLYAMIDE

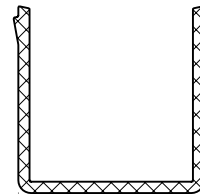

G.0307.LN

ABBINAMENTI
COMBINED

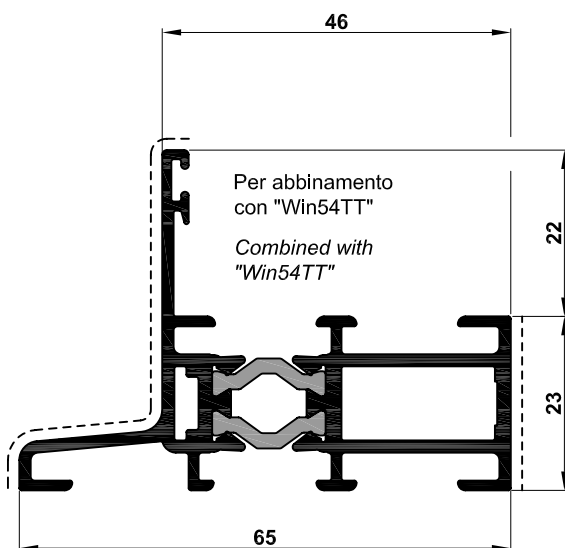

1F26016

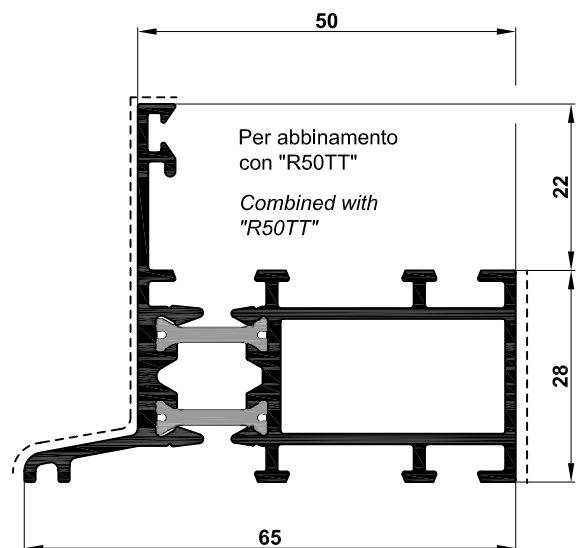

R50C102

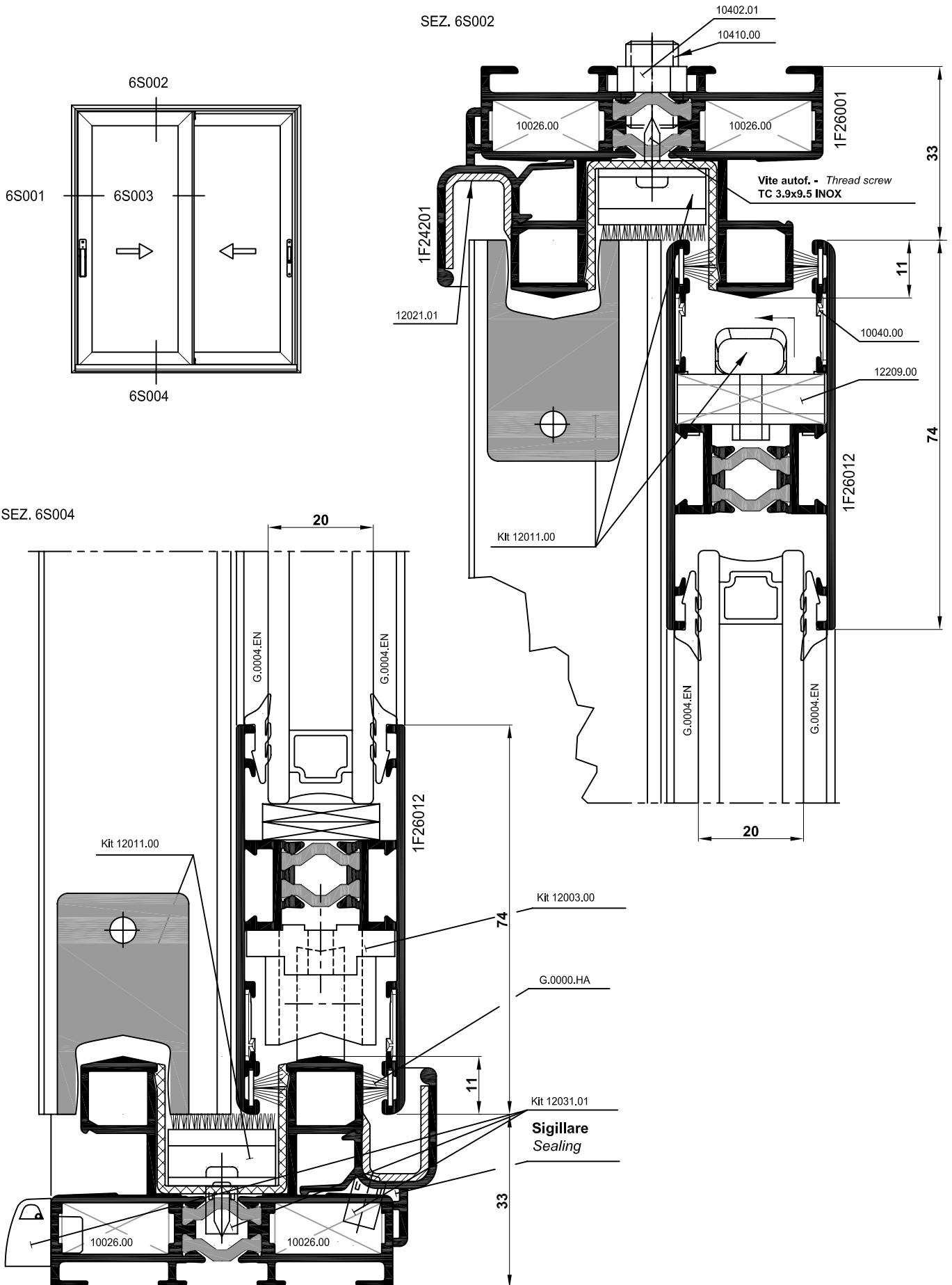

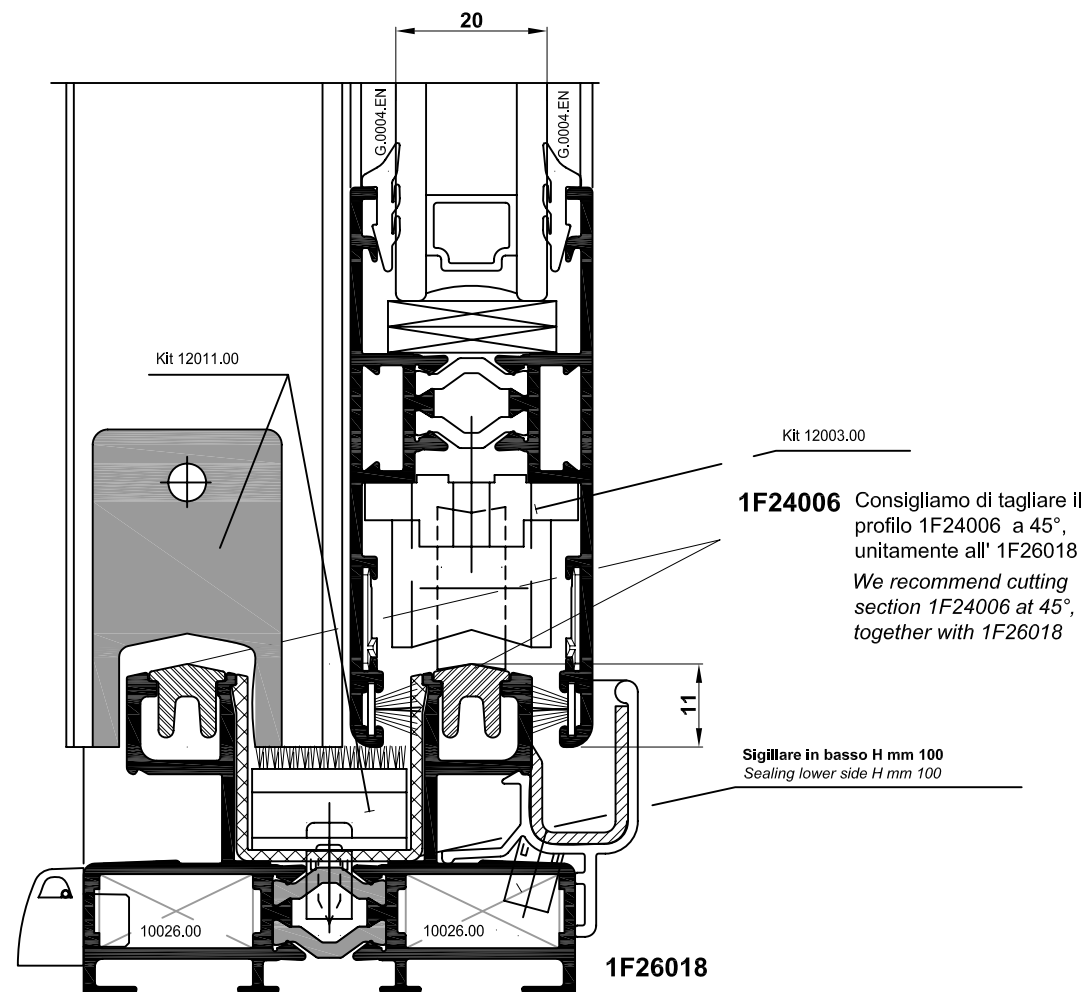
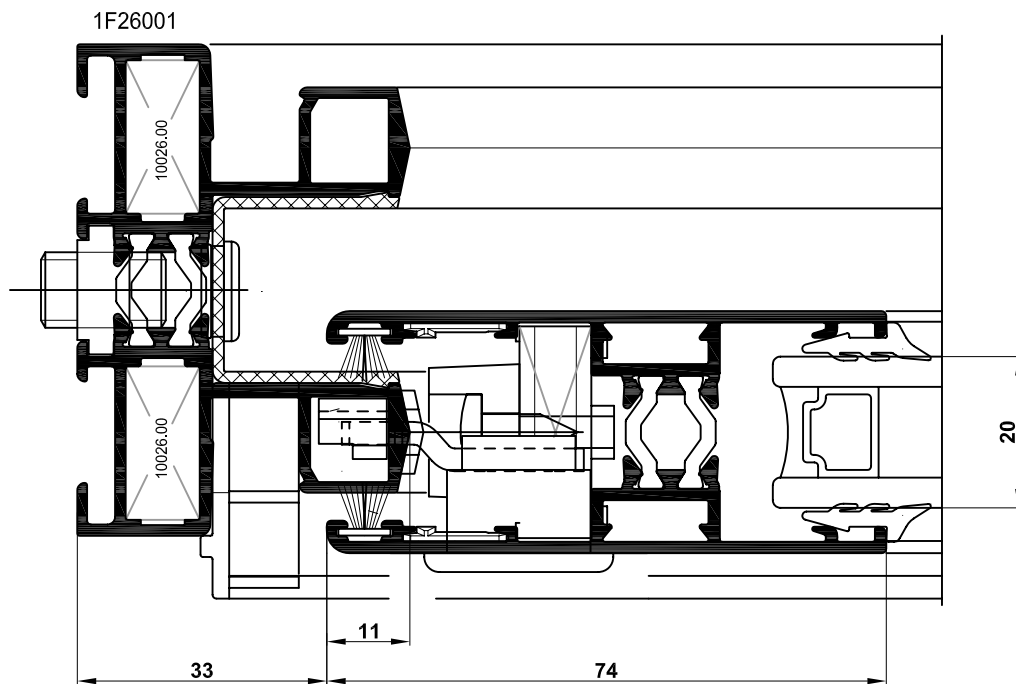

SEZ. 6S001

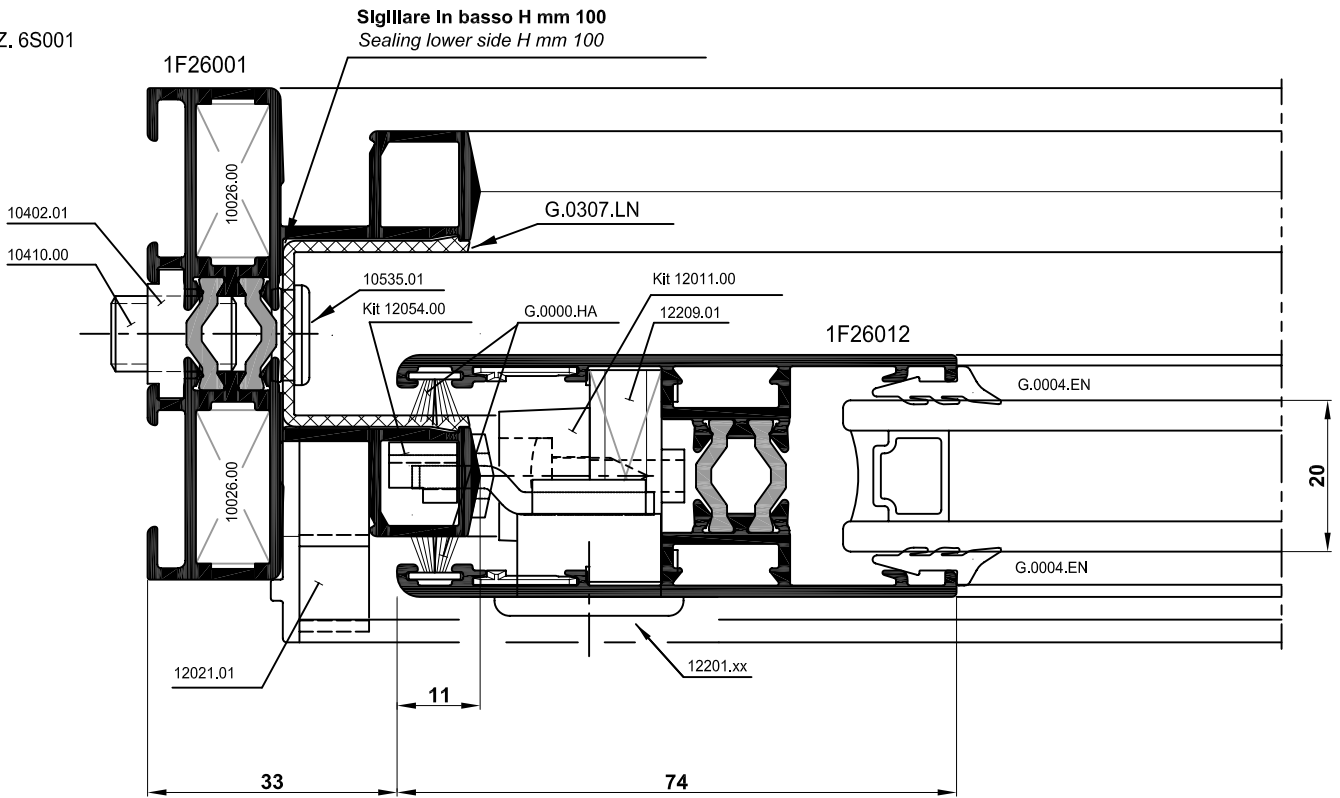

SEZ. 6S003

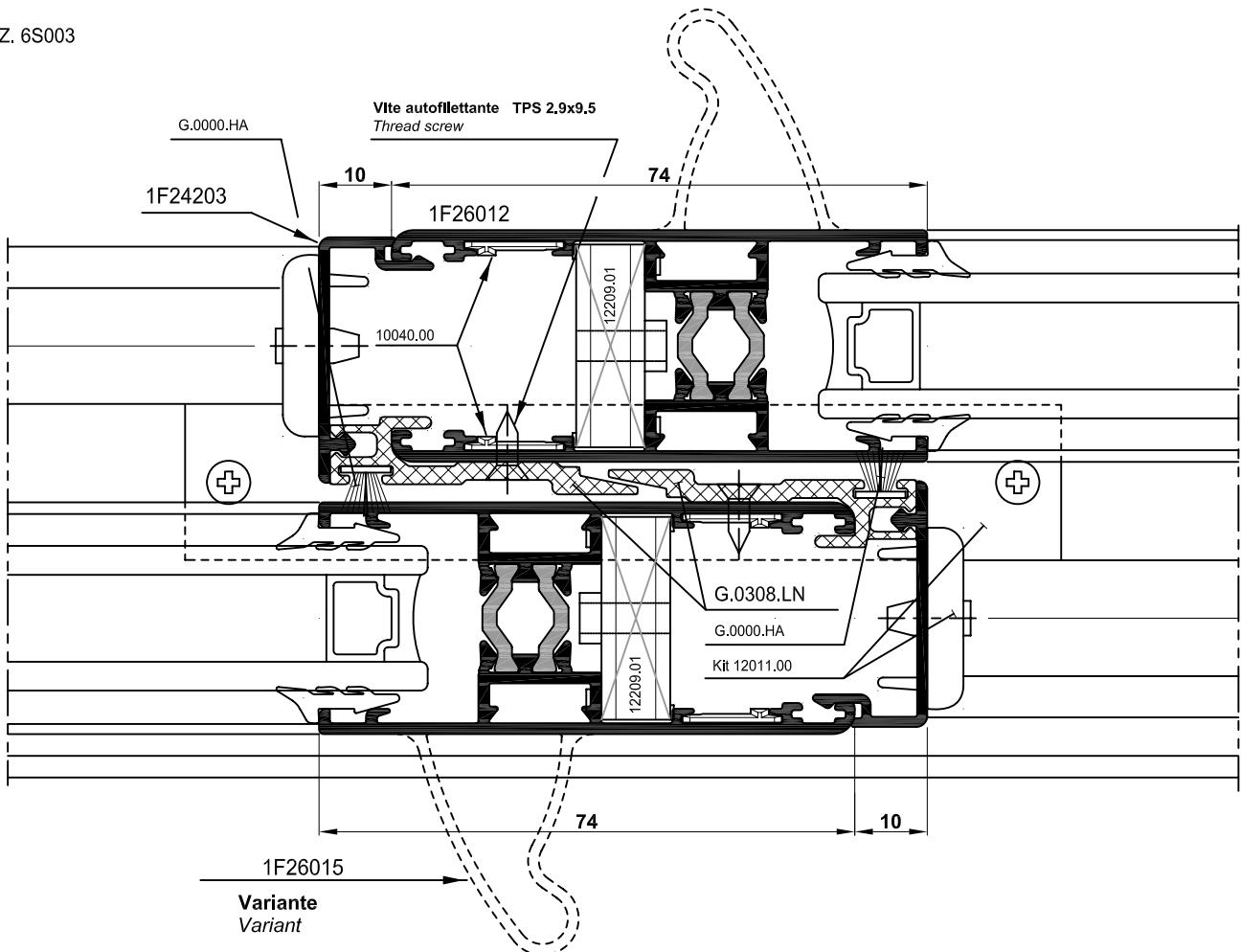

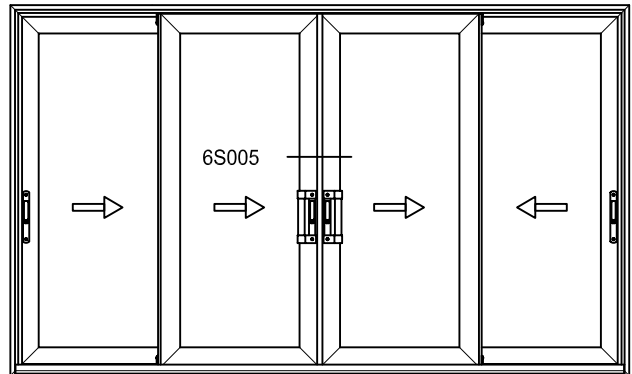
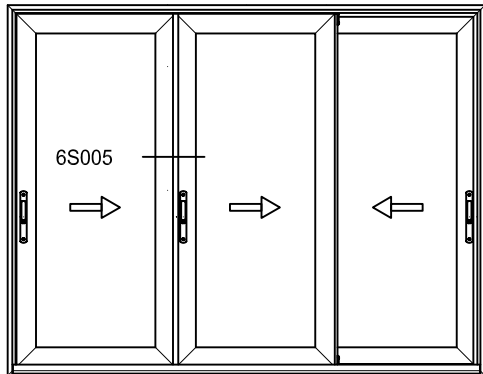

SEZ. 6S005

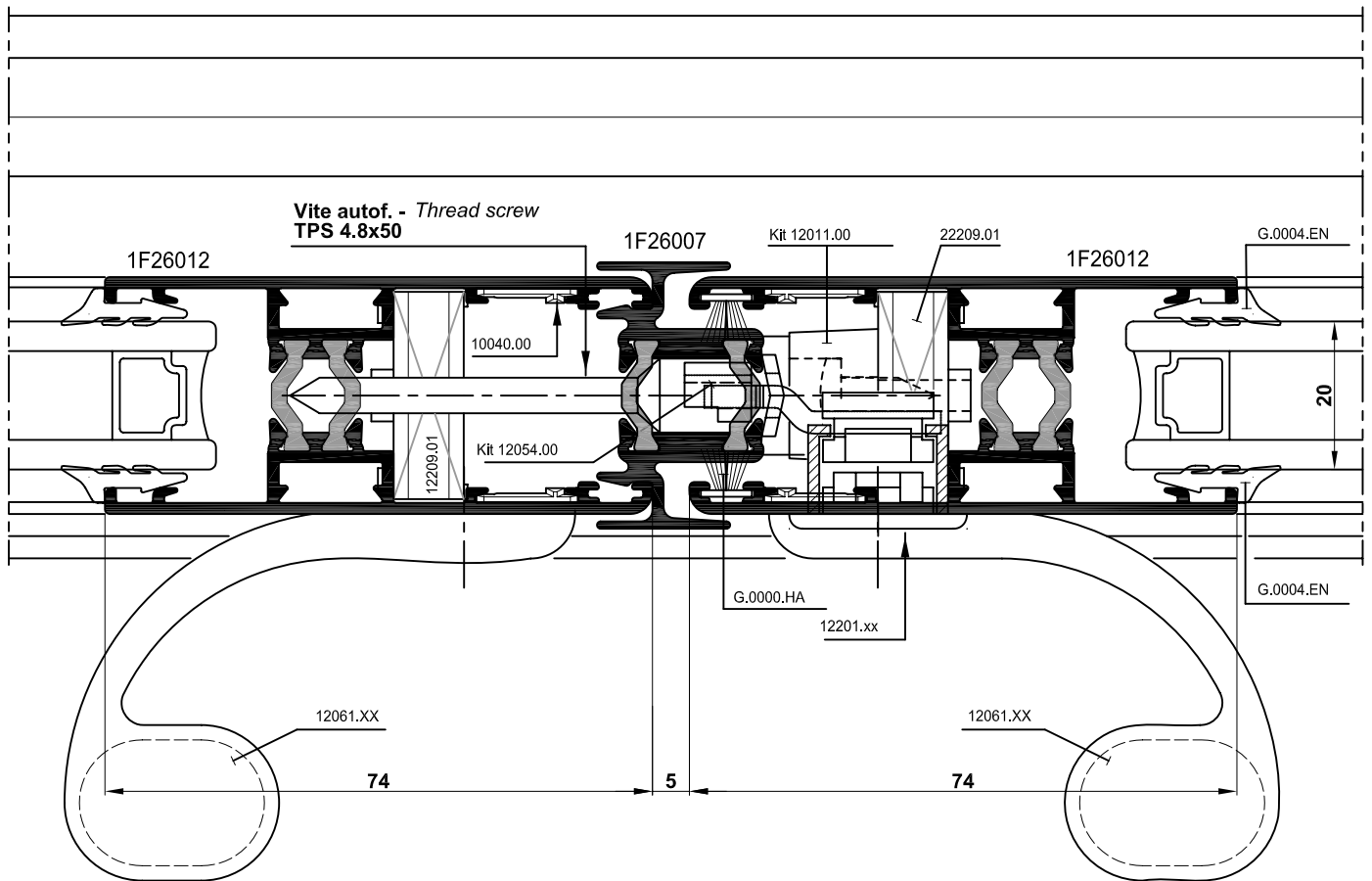

SEZ. 6S006

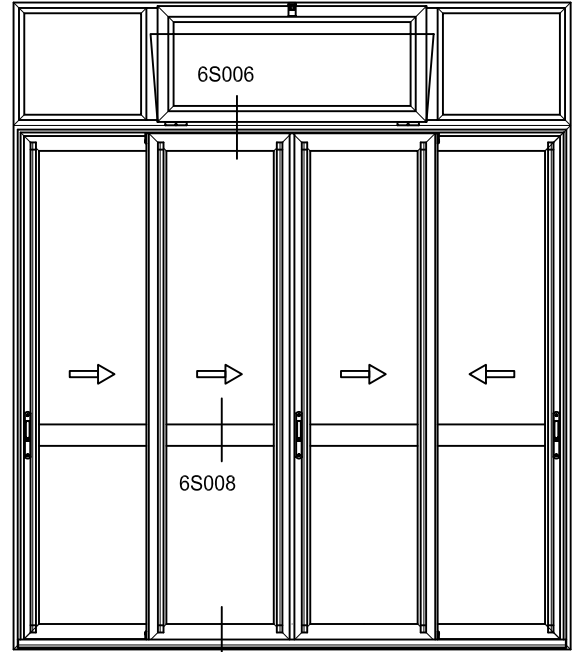
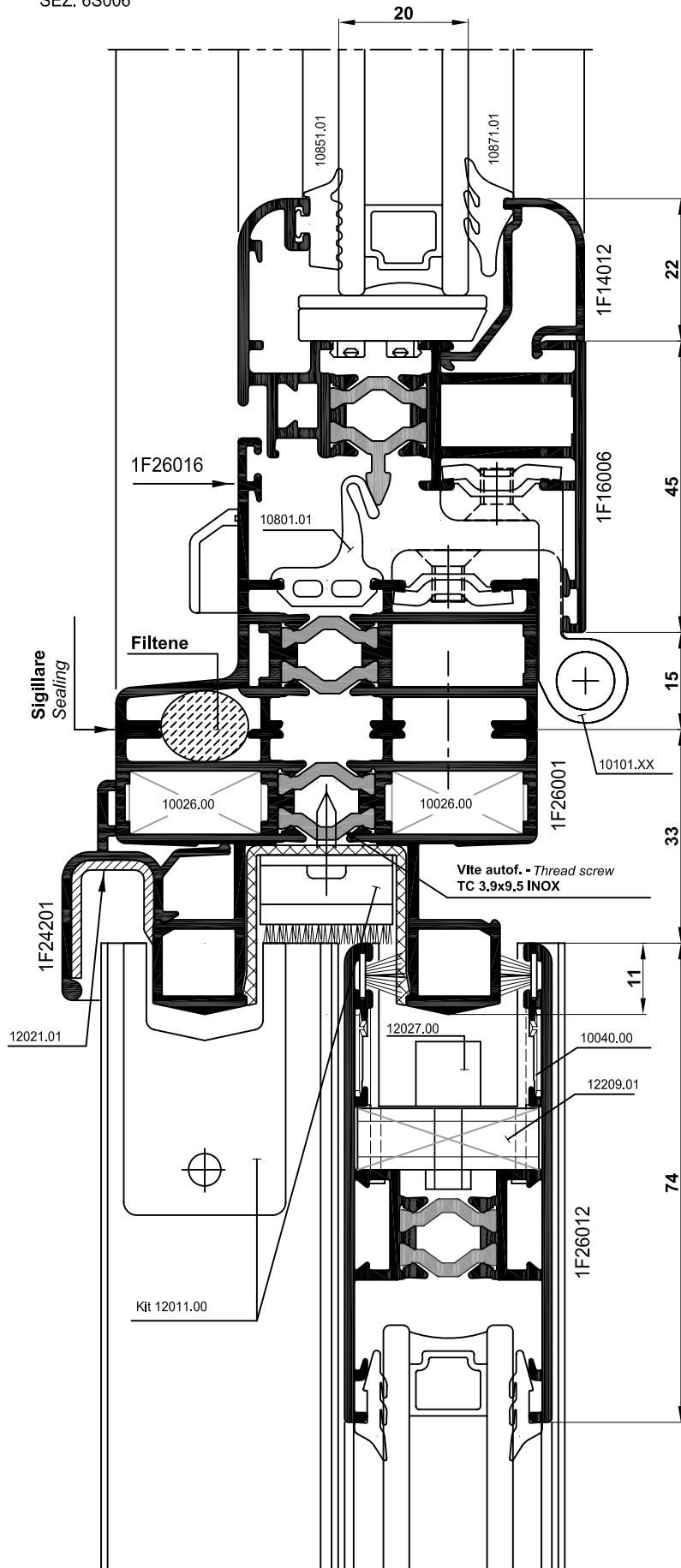

6S004

SEZ. 6S008

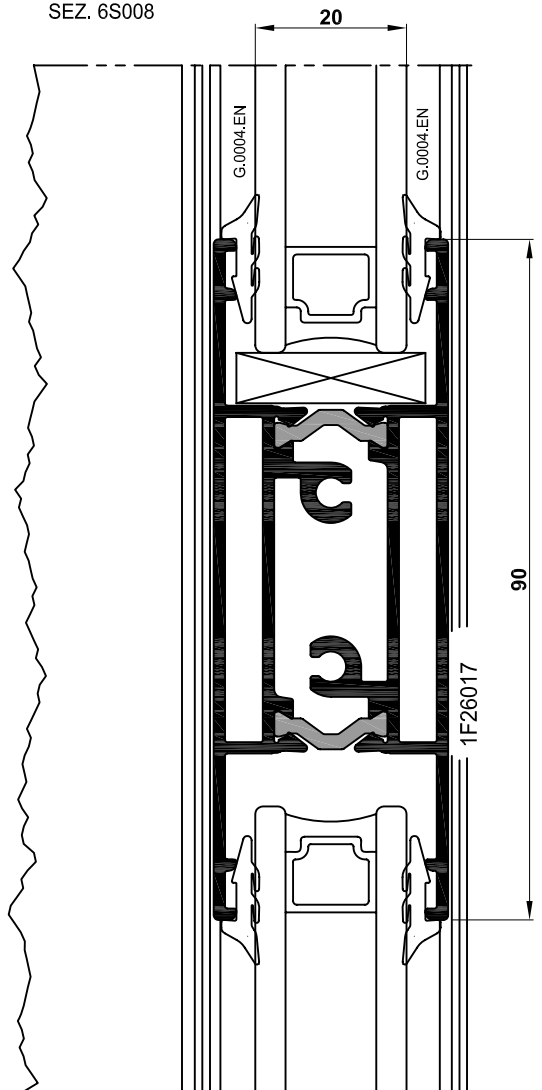

SEZ. 6S009

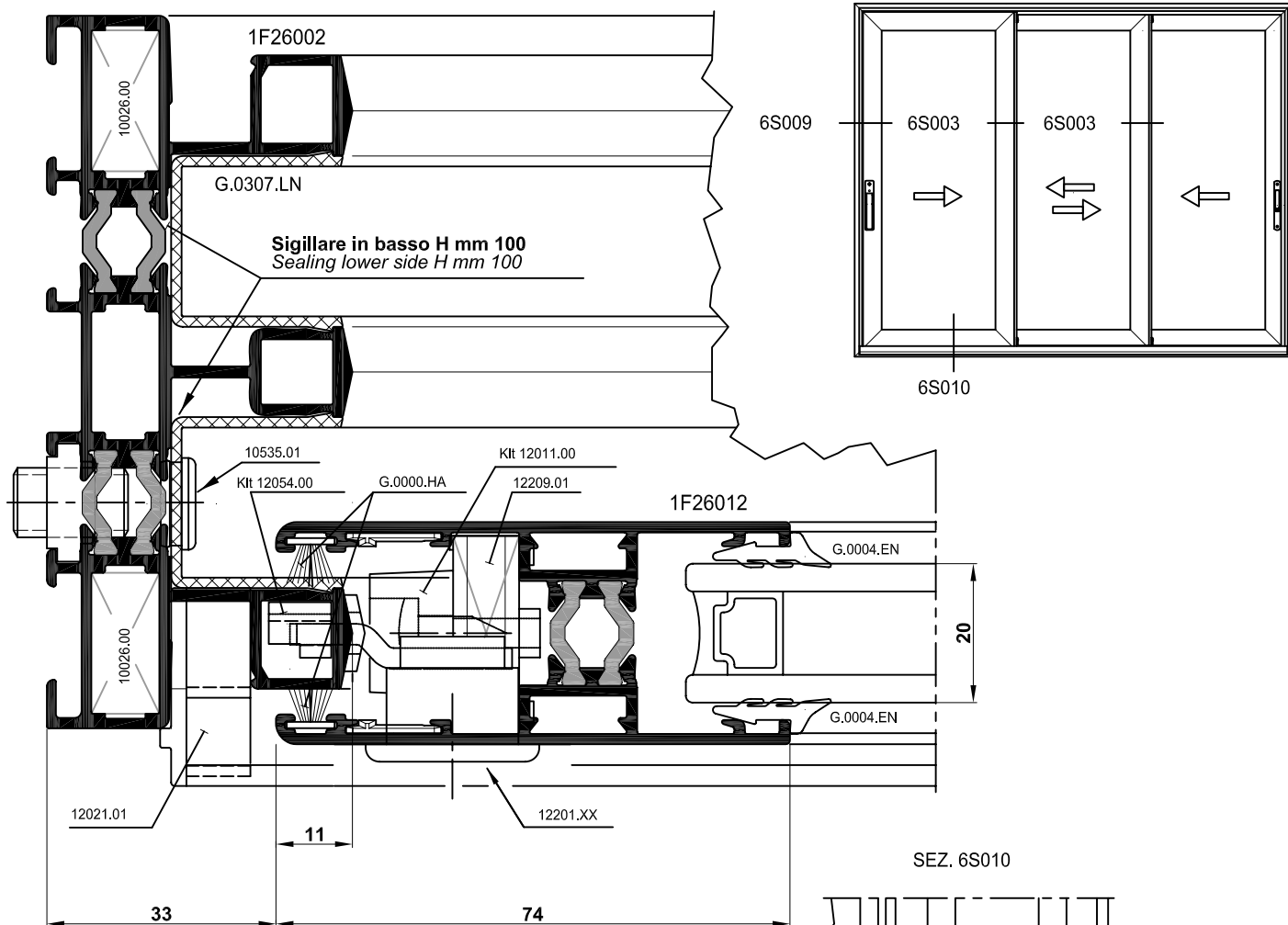



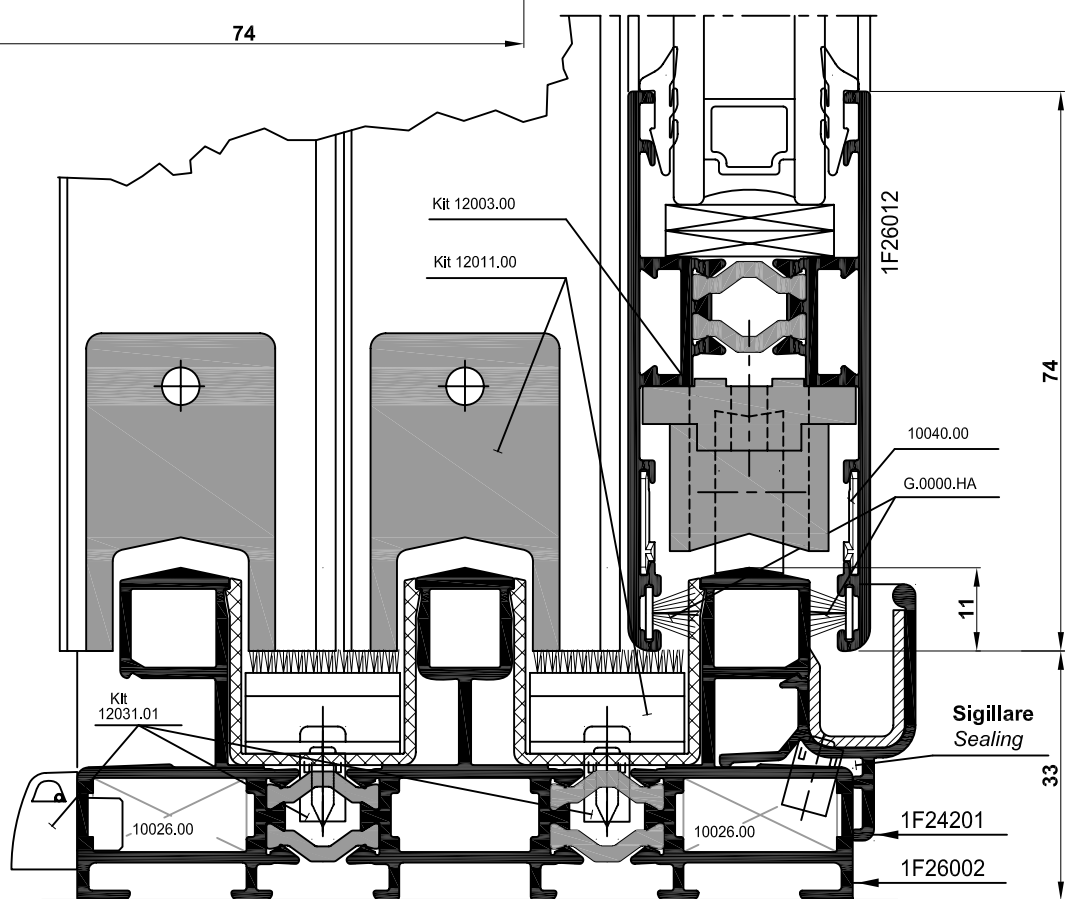

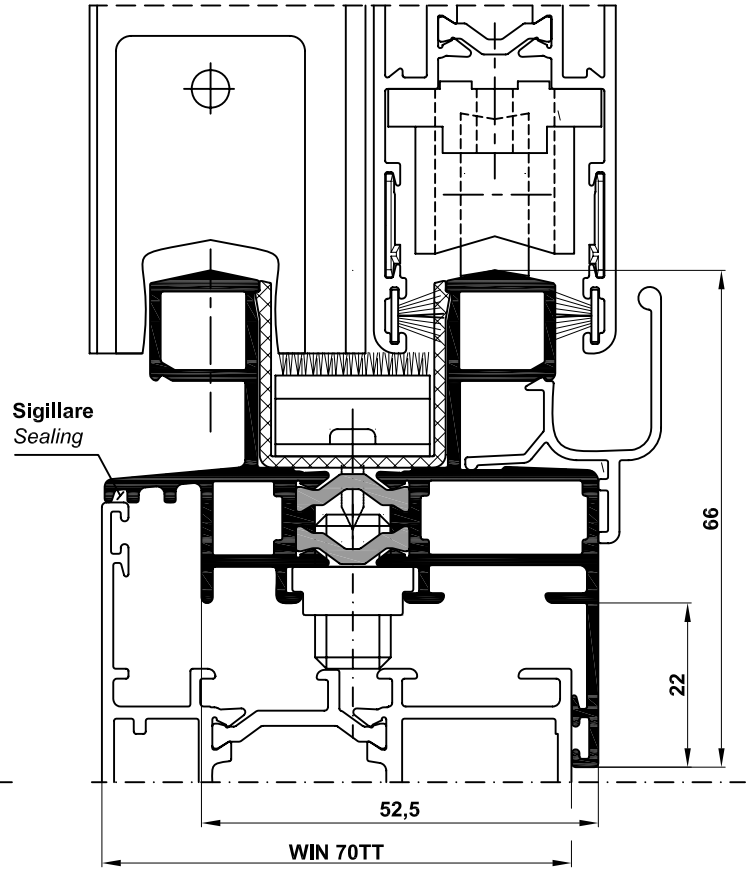
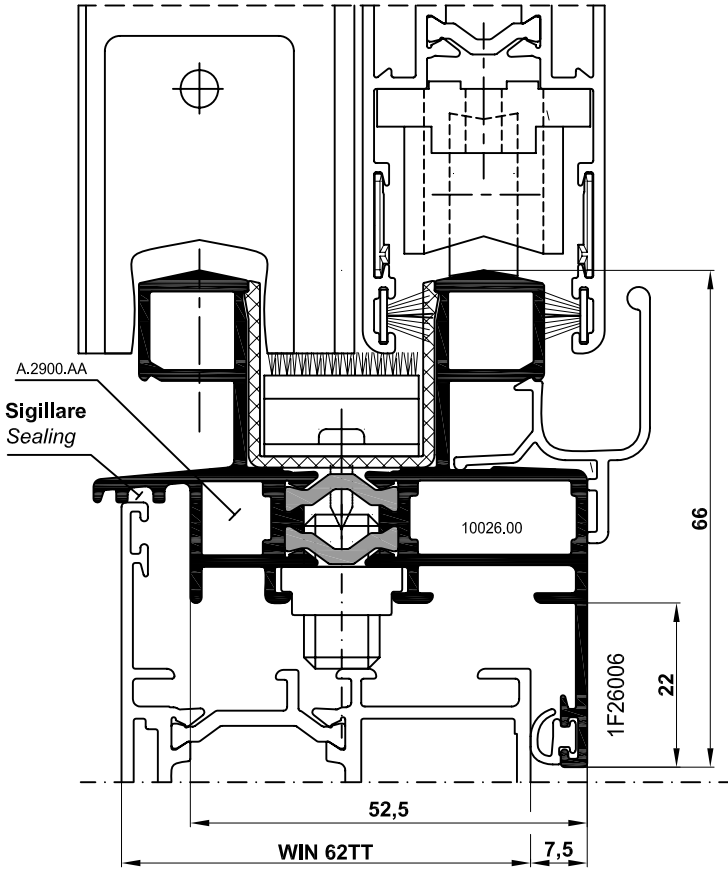
SEZ. 6S010



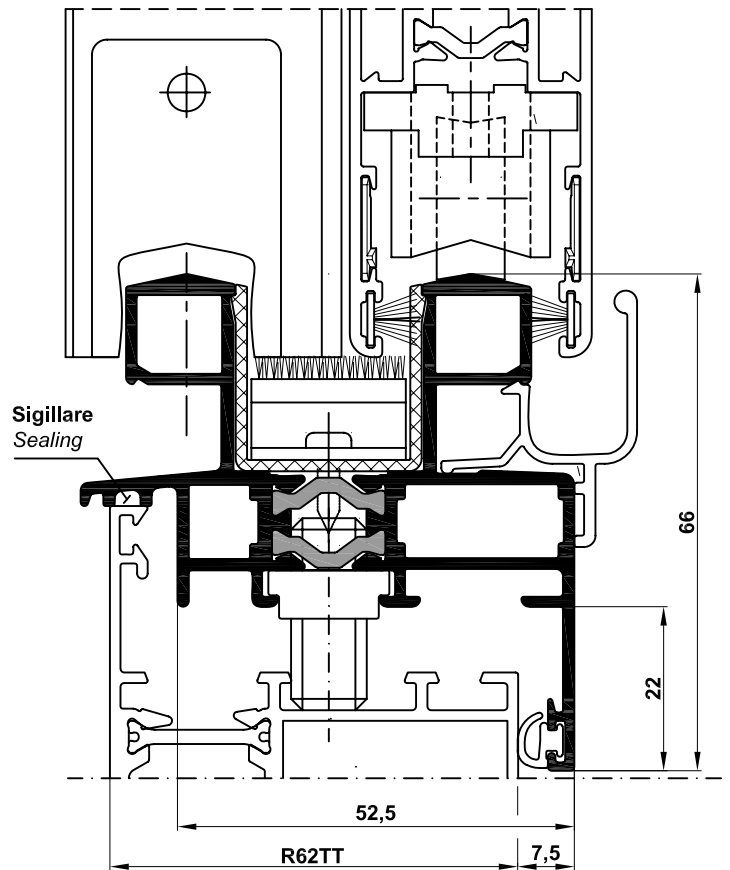
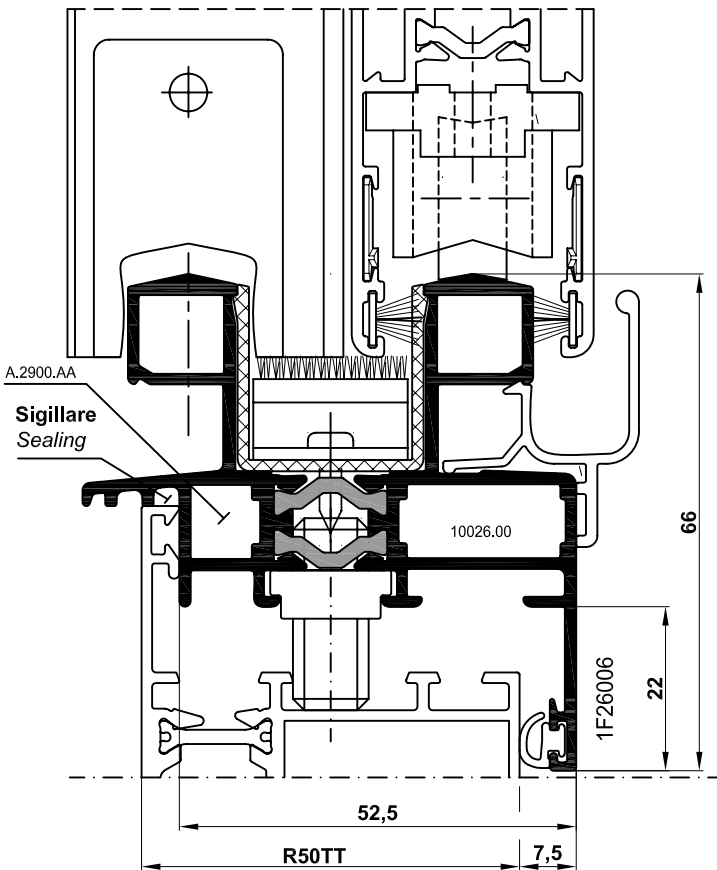

Sistema R^{TT}

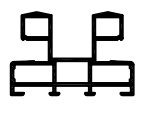
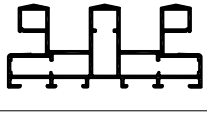
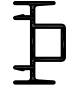
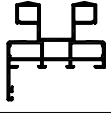
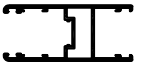
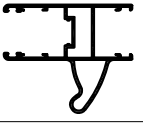
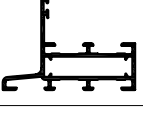
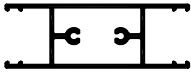
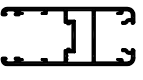
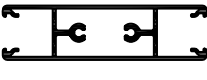

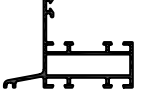
Profilato Section	Sezione Cross section 	Peso Weight Kg/m	Perimetro Perimeter mm	Superficie in vista Exposed surface m ² /m	Jx cm ⁴	Wx cm ³	Jy cm ⁴	Wy cm ³
1F21001		1,380	379	0,223	9,40	3,86	20,03	6,16
1F21002		1,968	524	0,245	13,64	5,70	72,83	14,20
1F21007		0,460	190	0,056	2,23	1,24	0,62	0,55
1F21010		1,480	437	0,249	2,23	1,24	0,62	0,55
1F21012		0,972	401	0,162	6,53	4,08	14,63	3,87
1F21015		1,265	450	0,211	15,82	4,04	15,92	3,98
1F21016		0,892	341	0,087	3,65	1,16	11,94	3,41
1F21017		1,231	346	0,192	6,74	4,35	26,77	5,95
1F21018		1,045	438	0,182	6,70	4,18	17,45	4,35
1F21019		1,218	368	0,200	3,88	3,23	31,27	6,95
1F24201		0,262	144	0,083	-	-	-	-
1F24202		0,433	224	0,088	-	-	-	-
800785		0,863	349	0,090	4,12	1,33	10,57	2,95

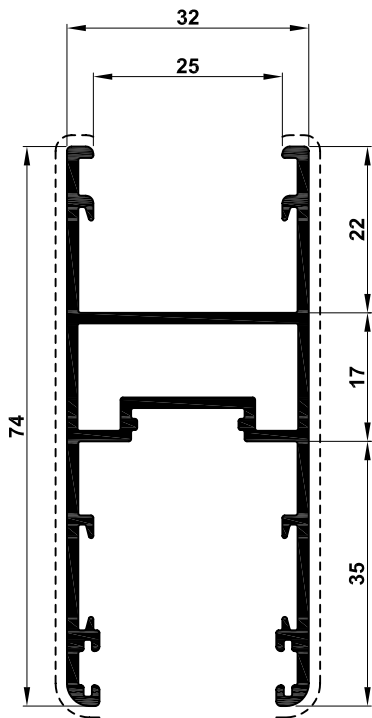

1F21012

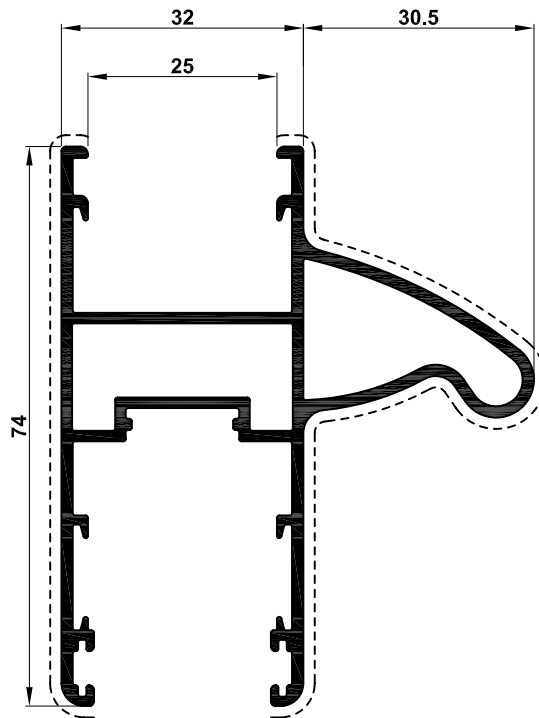

1F21015

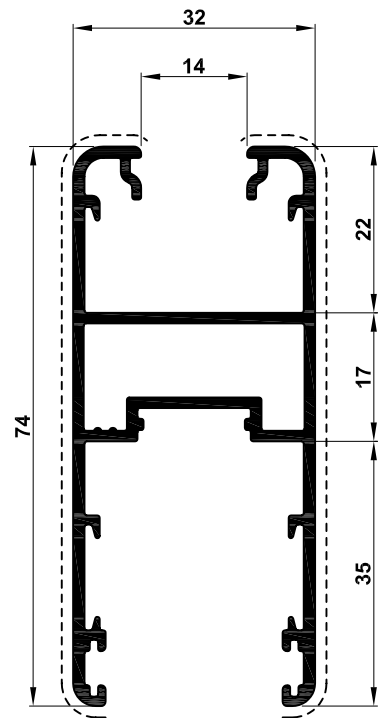

1F21018

FASCE
BANDS

RIPORTO 3^a E 4^a ANTA
3°- 4° WING FILLING

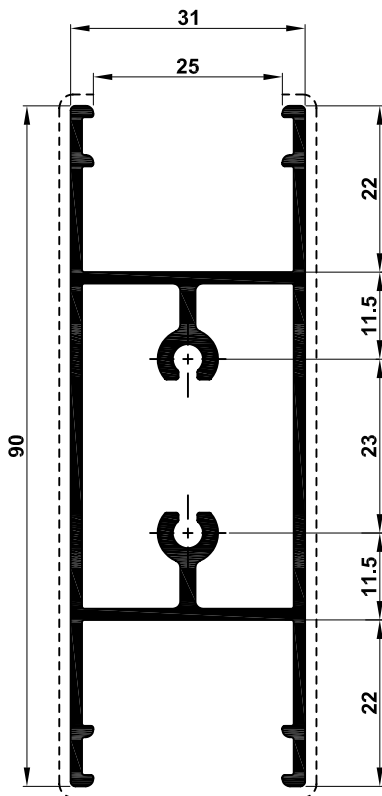

1F21017

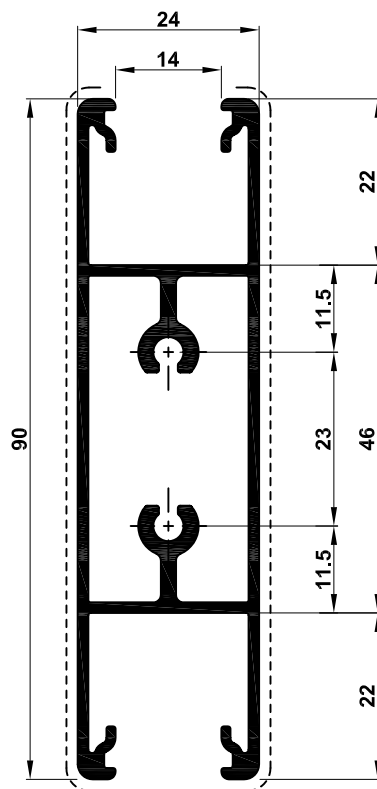

1F21019

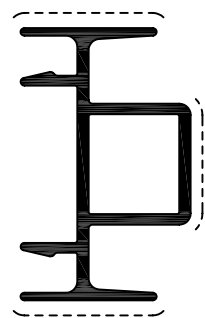

1F21007

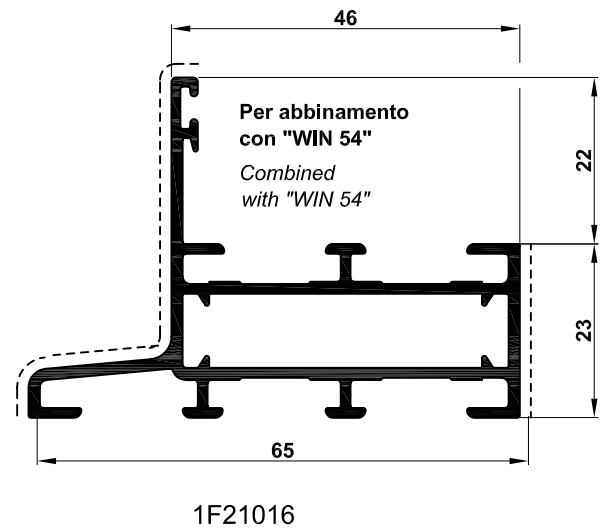
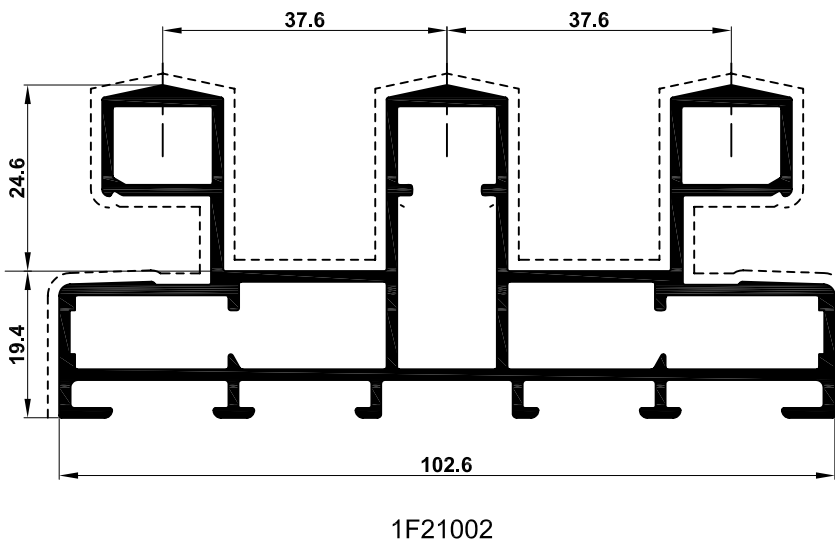
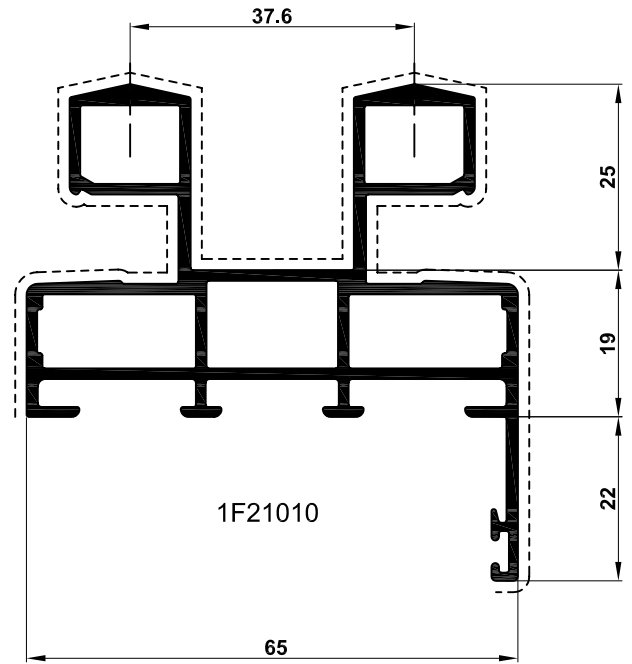
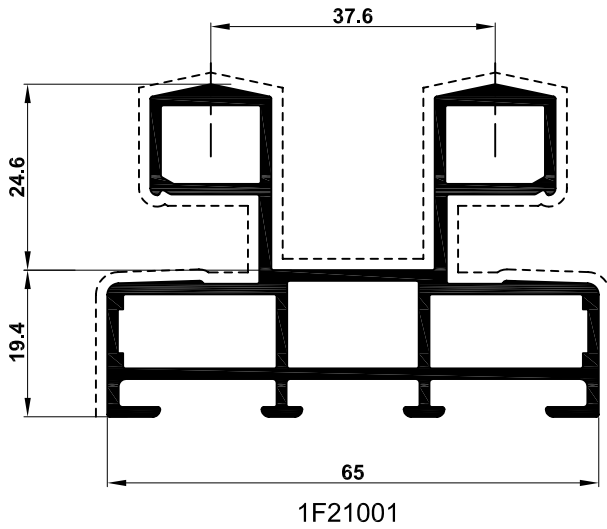

VARI
DIFFERENT SECTIONS

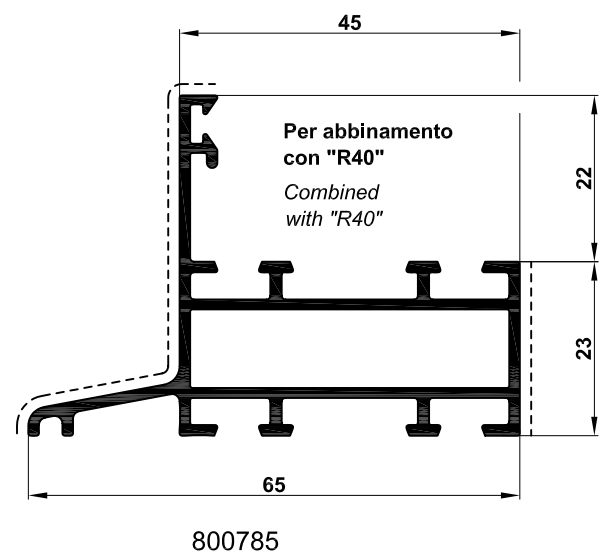
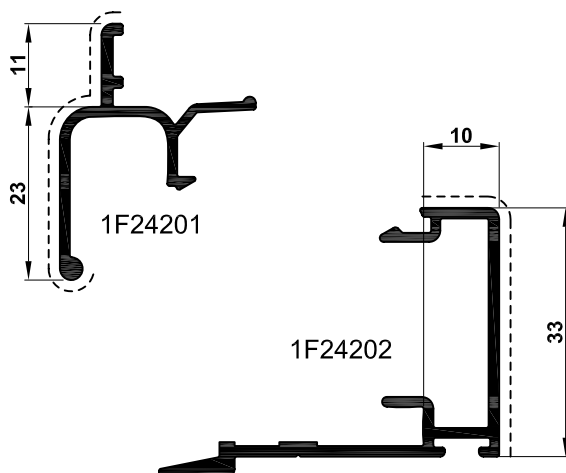

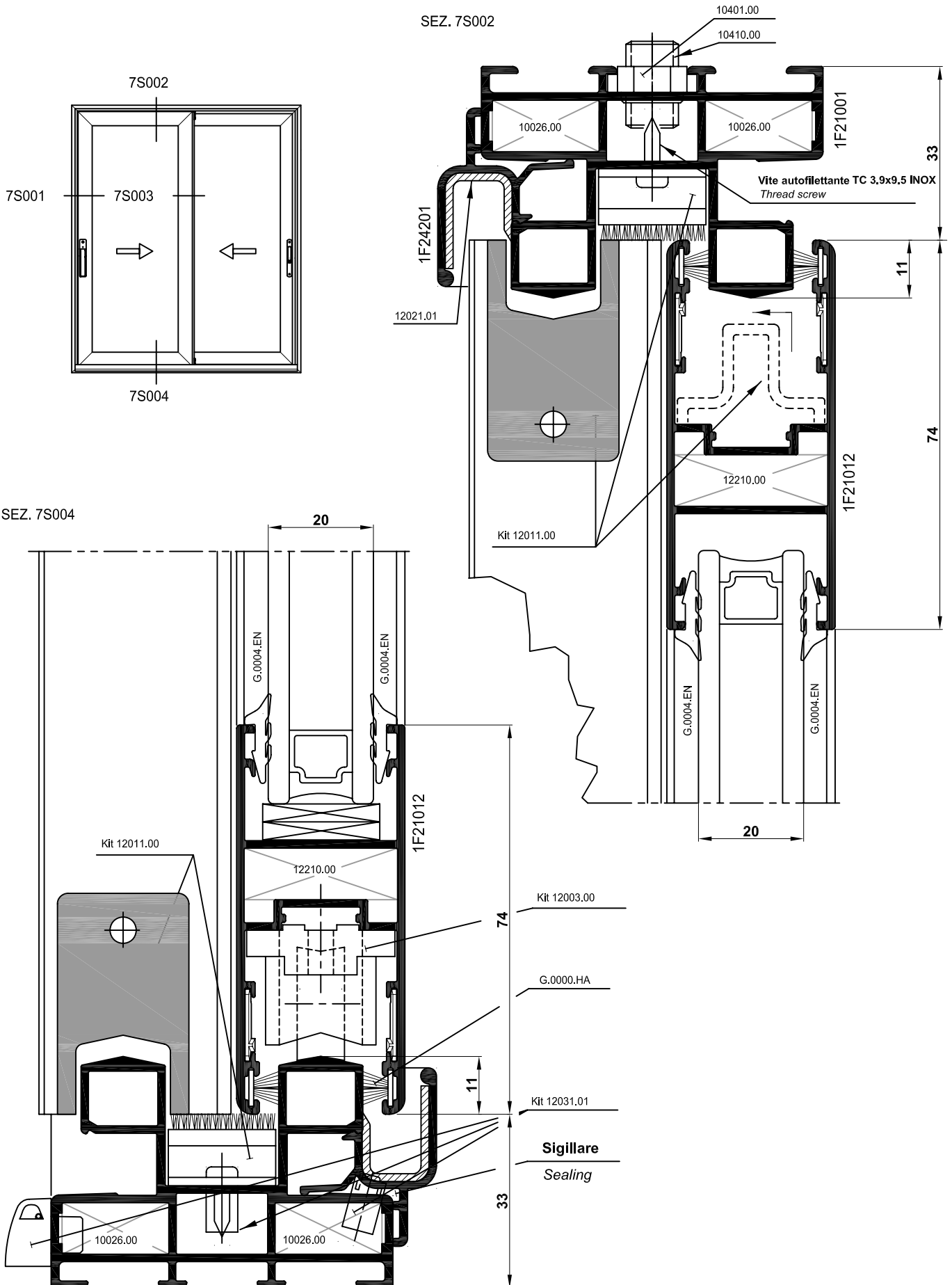

SEZ. 7S001

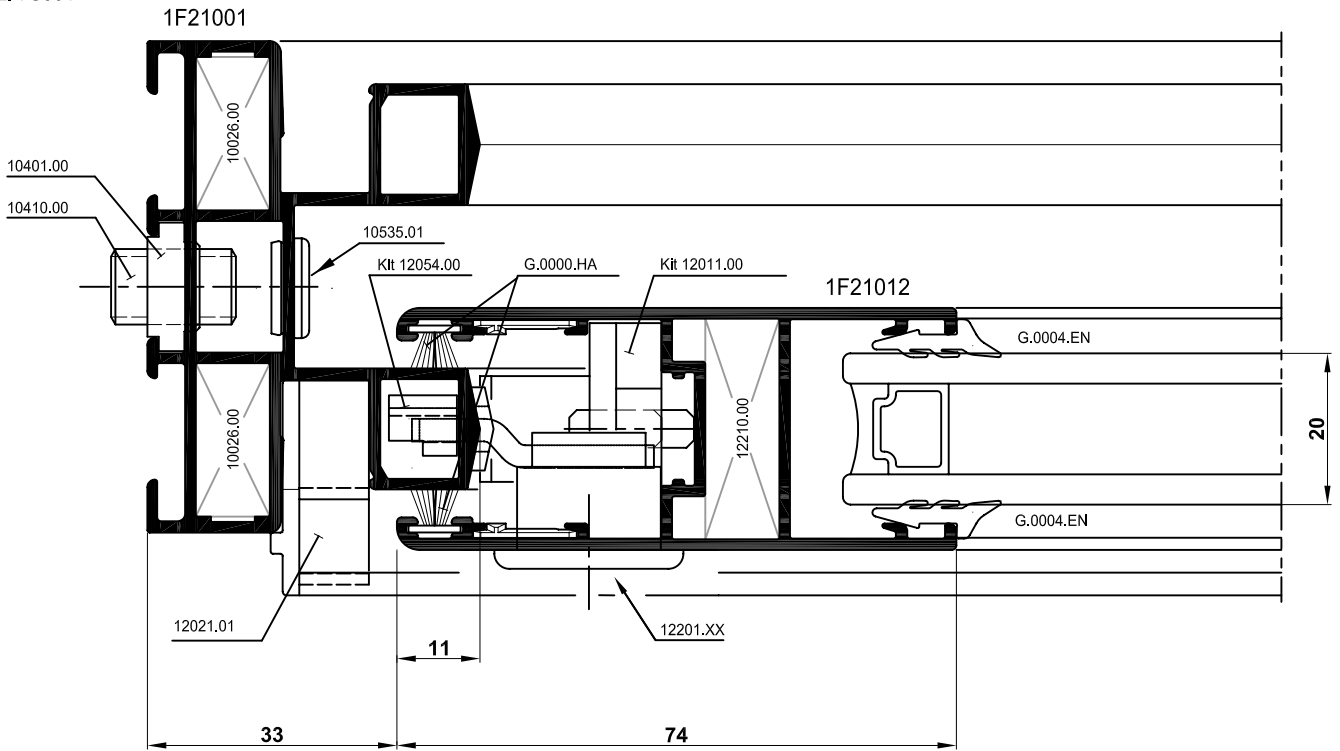

SEZ. 7S003

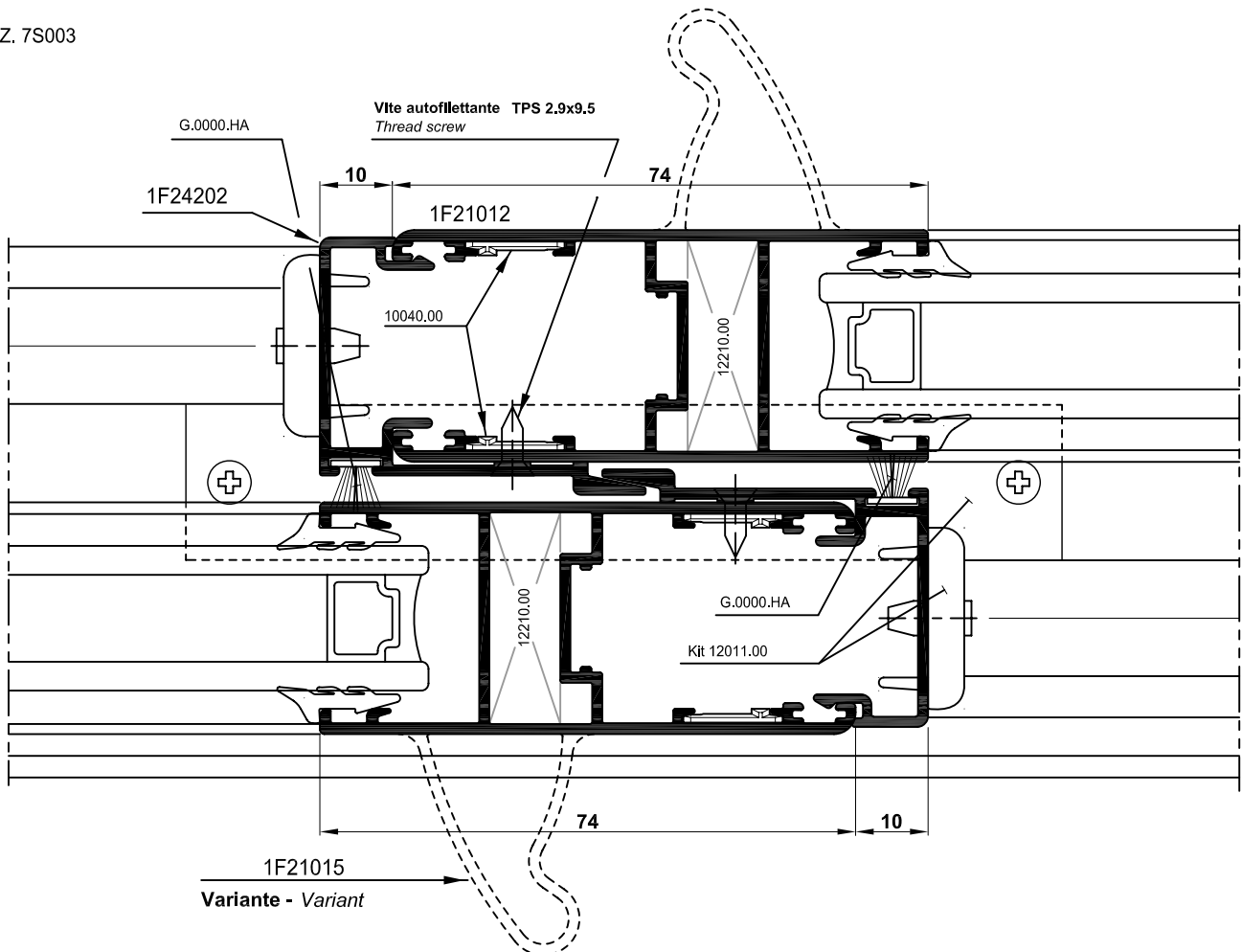

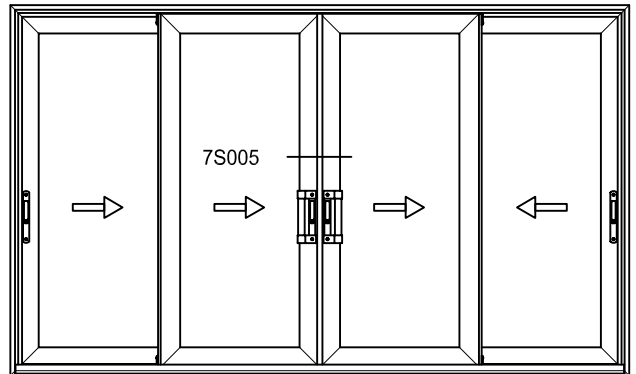
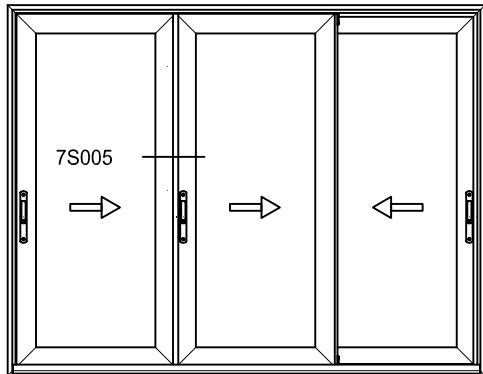

SEZ. 7S005

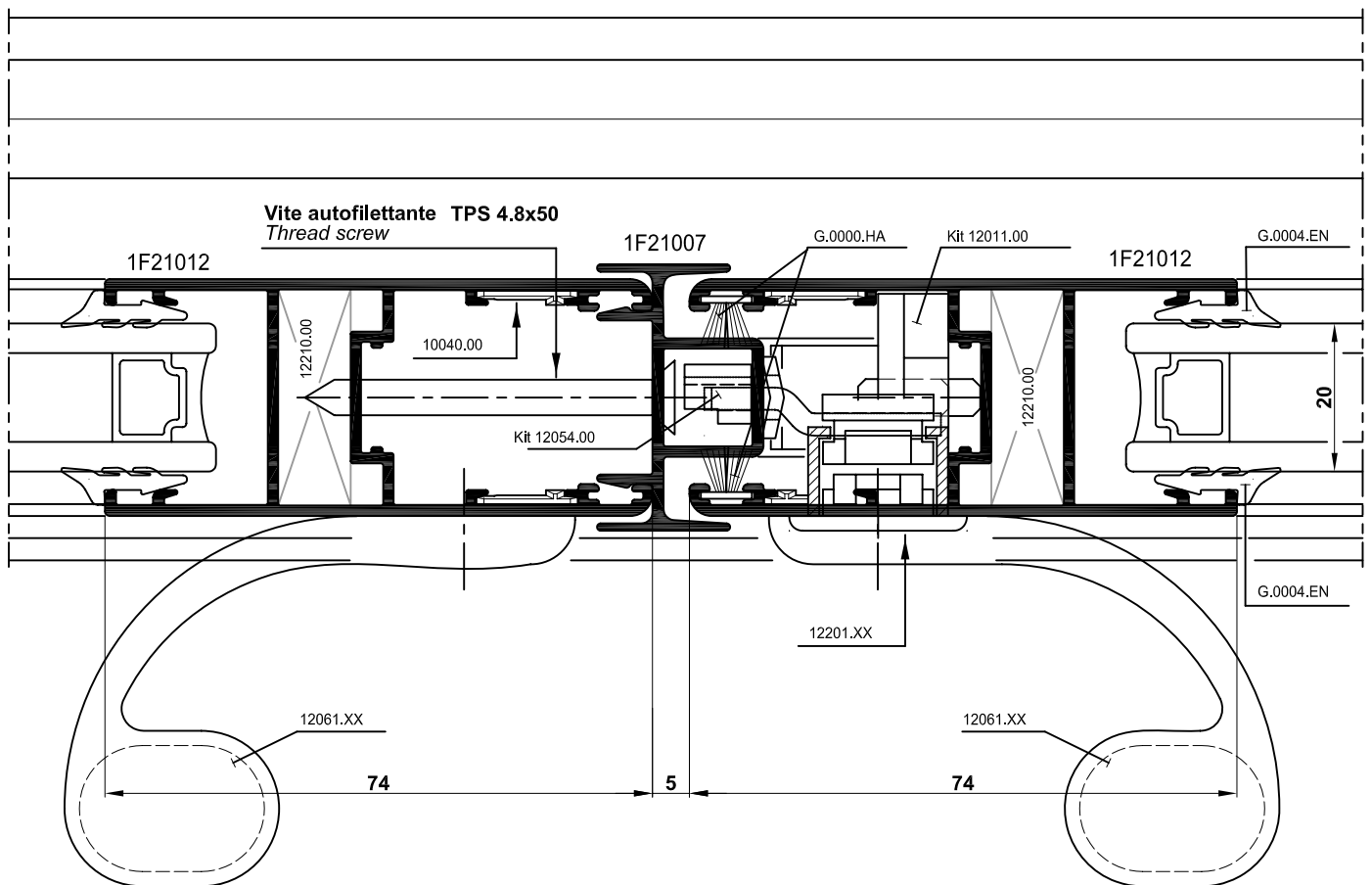

SEZ. 7S006

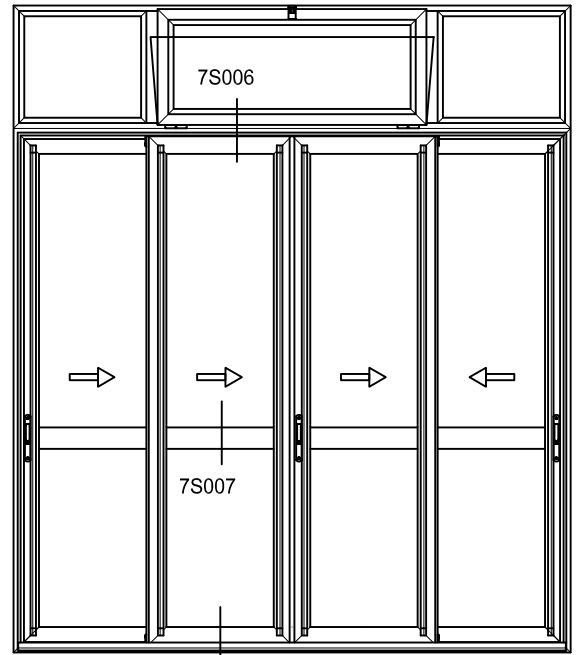
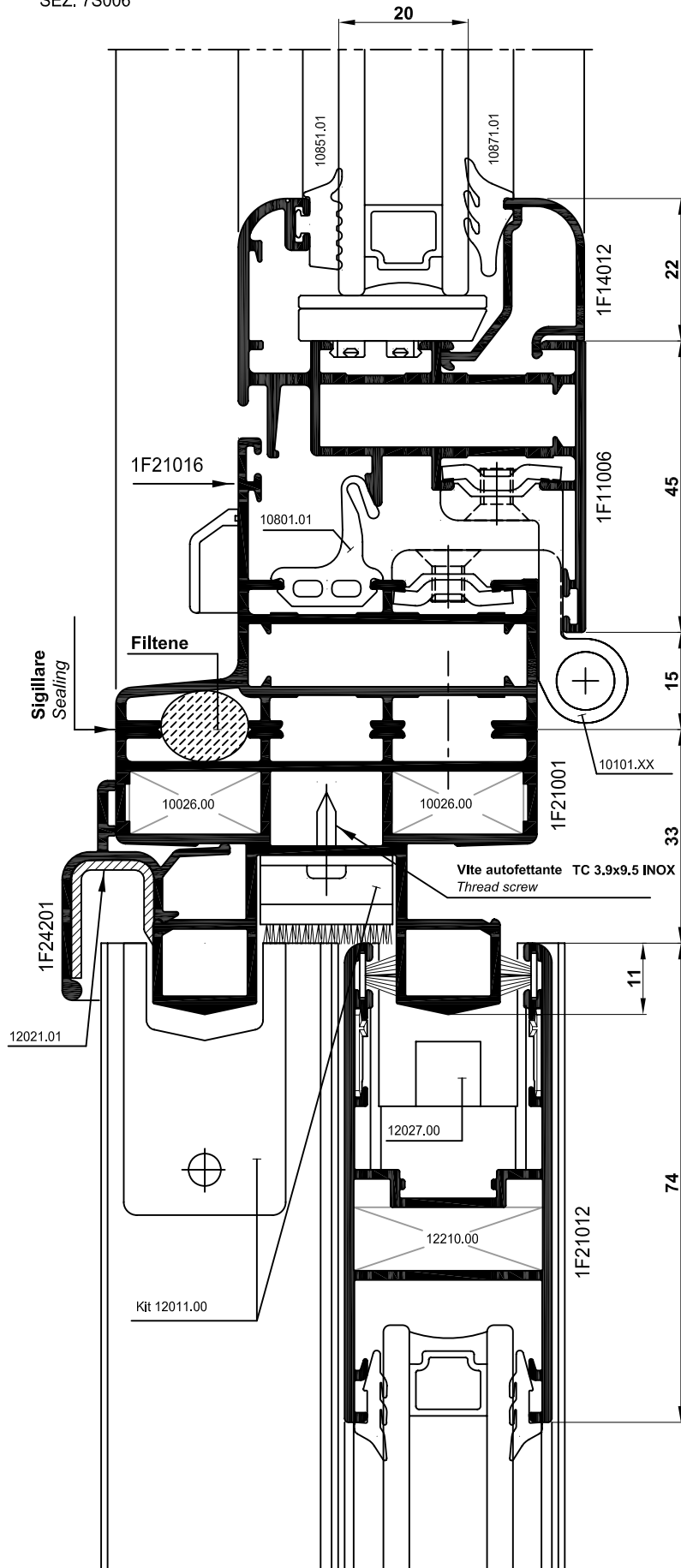

7S004

SEZ. 7S007

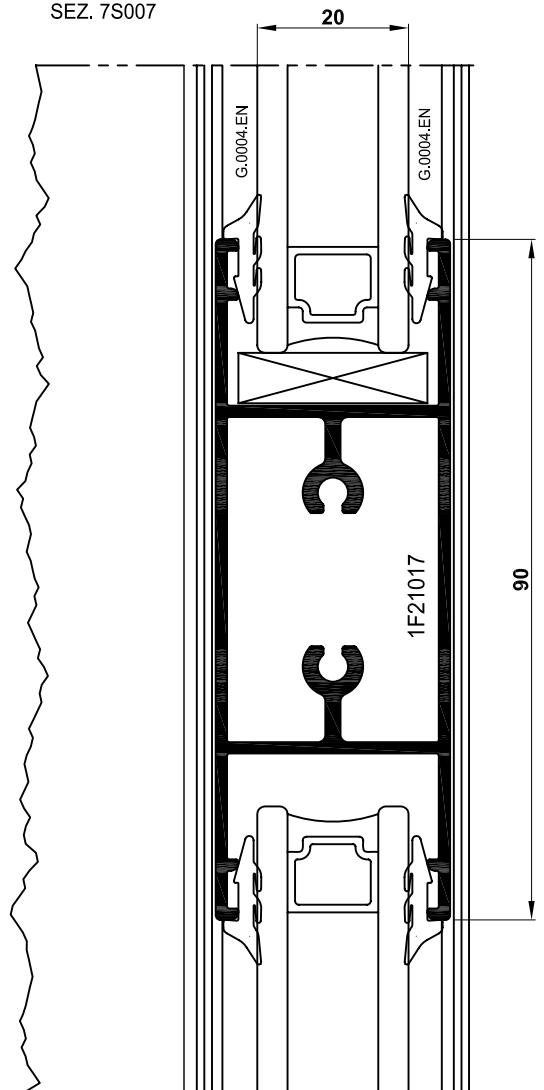

SEZ. 7S008

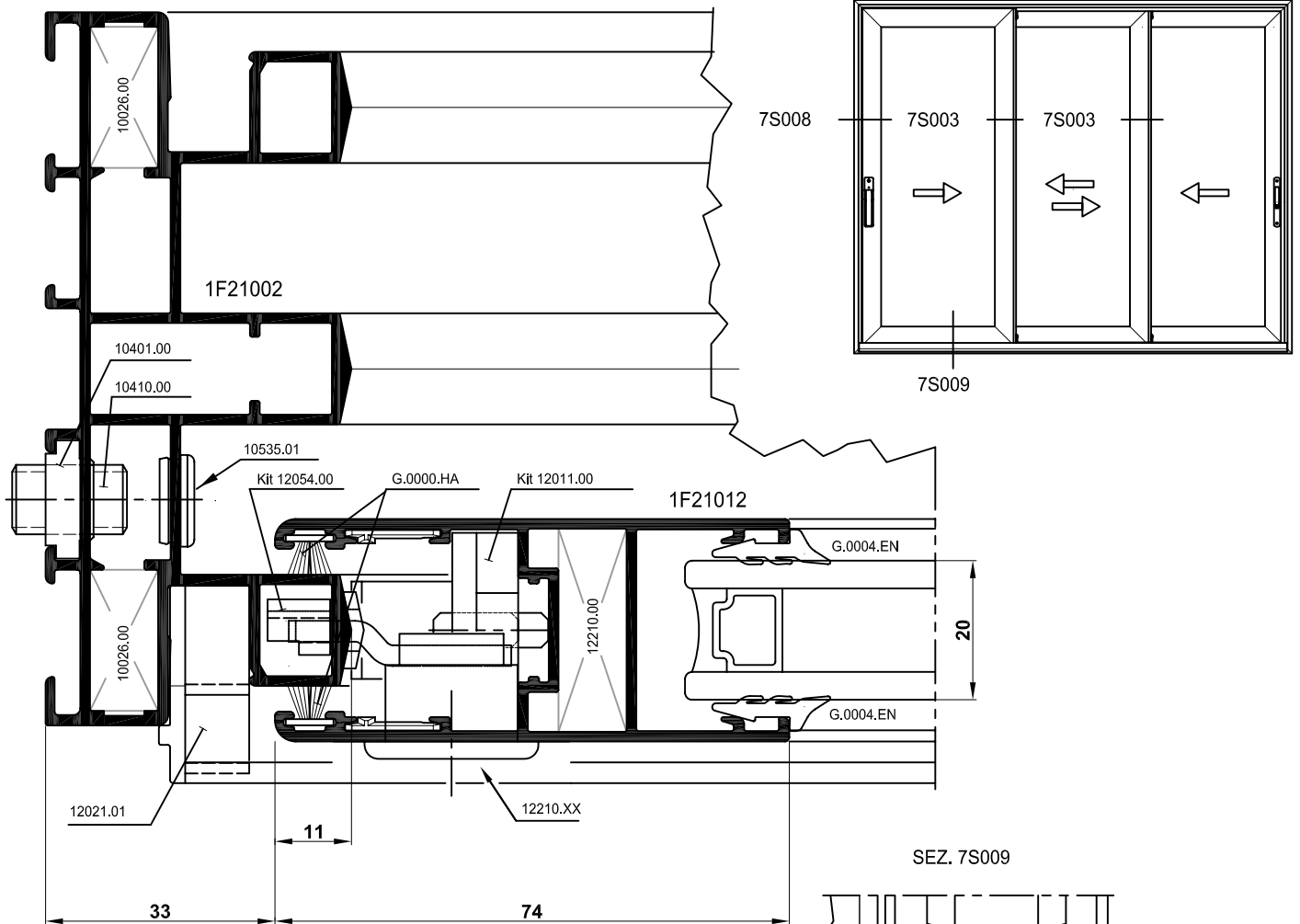

SEZ. 7S009

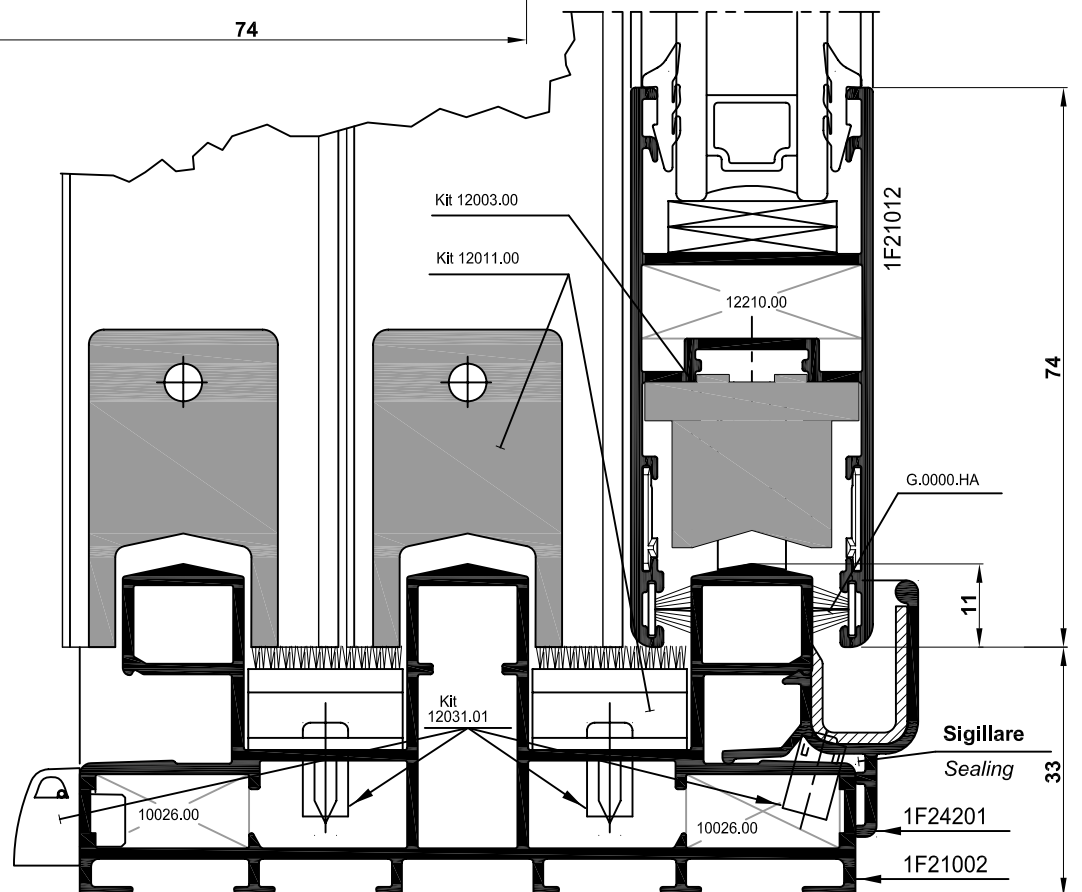

N.B: - Le dimensioni di taglio e di lavorazione indicate nelle pagine seguenti sono state ottenute considerando le quote teoriche.
 Pertanto è necessario verificare sempre le dimensioni dei profilati prima di effettuare i tagli.
 Sapa declina ogni responsabilità per errori dovuti al mancato controllo da parte del costruttore.

SEZ. B-B



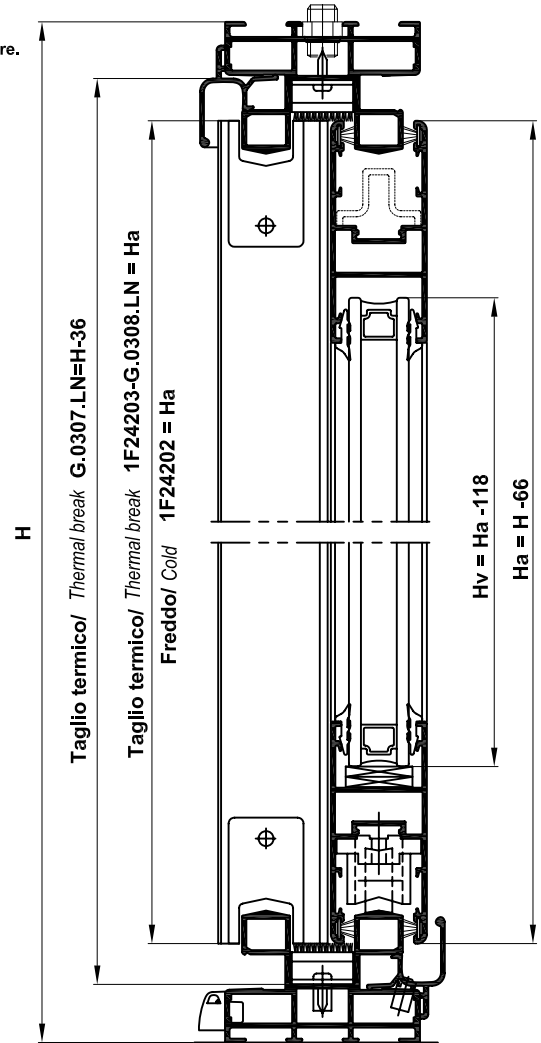
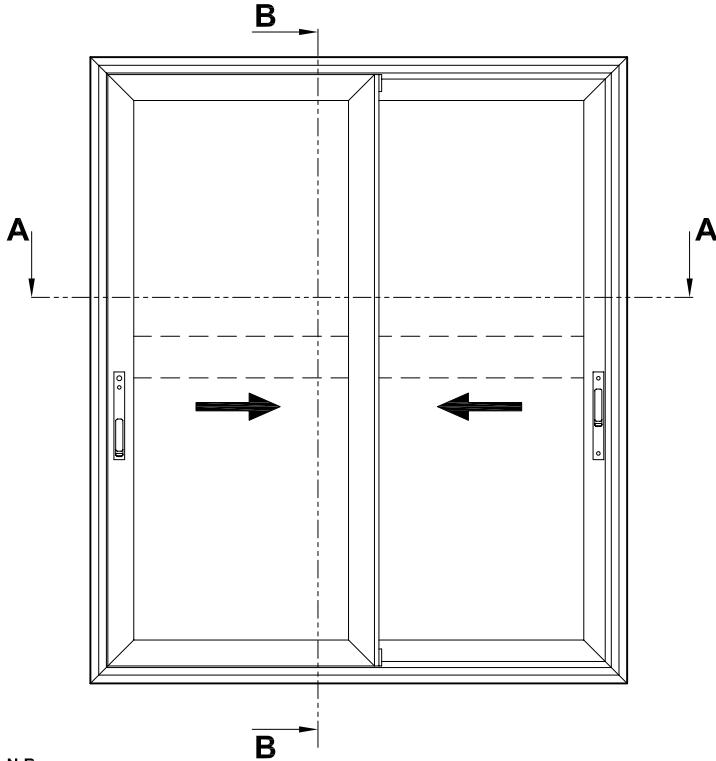





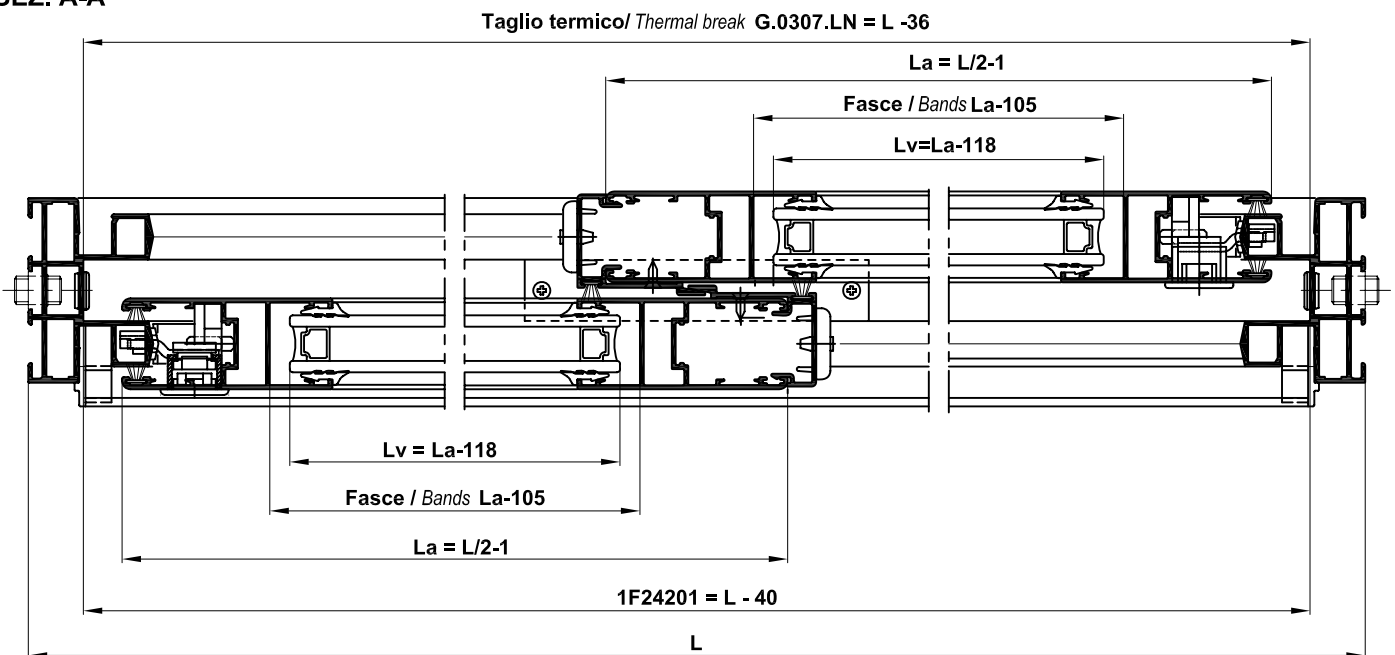



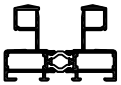
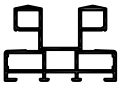

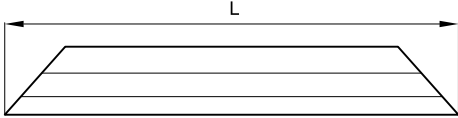

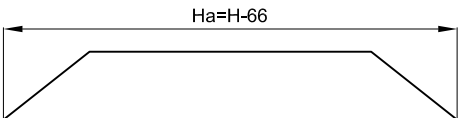

N.B: - The cutting and processing dimensions, indicated in the following pages, are obtained considering theoretical values.
 It is, therefore, always necessary to check the dimensions of the profiles before executing the cutting.
 Sapa declines any responsibility from errors caused from the missing dimensional check of the carpenter

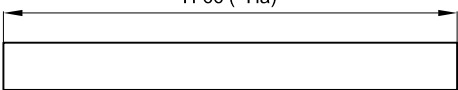

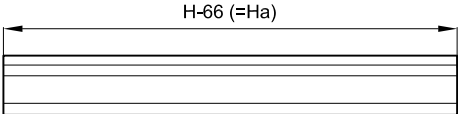
N.B.
 Spessore vetro considerato 20mm
 Gioco perimetrale tra profilato in alluminio e vetro 7mm
 For glass with 20mm thickness
 Space between glass and aluminium section 7mm

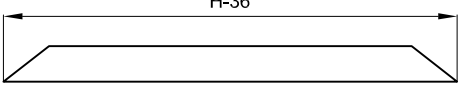
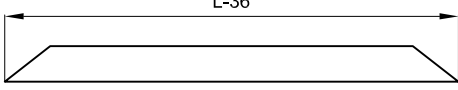
SEZ. A-A

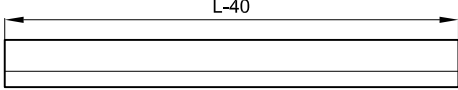

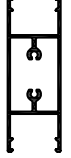
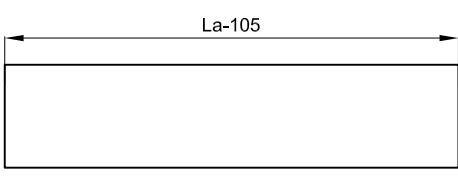
PROFILATO SECTION		N.Pz N.Pz	TAGLIO CUT	N.Pz N.Pz	TAGLIO CUT
					
1F26001 	1F21001 	2		2	
1F26012 	1F21012 	2		2	
1F24203 	1F24202 	2			
G.0308.LN 		2			
G.0307.LN 		2	 Si consiglia di tagliarlo unitamente all'1F26001 We suggest to cut it together with 1F26001	2	 Si consiglia di tagliarlo unitamente all'1F26001 We suggest to cut it together with 1F26001
1F24201 	1F24201 			2	
1F26017 	1F21017 				

ACCESSORI WIN65TT / FREDDO
ACCESSORIES WIN65TT / COLD

ARTICOLO ITEM	DESCRIZIONE DESCRIPTION	N.	ARTICOLO ITEM	DESCRIZIONE DESCRIPTION	N.	ARTICOLO ITEM	DESCRIZIONE DESCRIPTION	N.
10040.01	Squadretta allineamento aletta Alignment corner joint on fin	32	10403.00	Basetta per regolo mobile in alluminio Aluminium plate for adjustable fixing	8			
10026.00	Squadretta ad avvitare (telalo) Corner joint to be screwed (frame)	8	10410.00	Grano per regolo mobile Dowel for adjustable fixing	8			
12210.00	Squadretta ad avvitare (anta) Corner joint to be screwed (leaf)	8	10535.01	Tappo copriforo Ø 12mm Hole plug Ø 12mm	8			
12209.01	Squadretta ad avvitare (anta TT) Corner joint to be screwed (TT leaf)	8	Comm.le	Tasselli spessoramento vetro Glass registration dolly	8			
10003.00	Variente: squadretta a cianfrinare (anta TT) Alternative: to be crimped corner joint (TT leaf)	16	12021.01	Tappi per gocciolatoio e raccoglicondensa (coppia) Drip channel and drip condensation plugs (pair)	2			
12003.00	Kit 4 carrelli regolabili 4 adjustable double rollers kit	1	12031.01	Kit valvola scarico acqua Water drain valve kit	1			
12011.00	Kit tappi per 2 ante (su TT con art.10003.00) Plug kit for 2 wings (to be used with 10003.00)	1	12054.00	Kit aggancio chiusura ad incasso Recessed clip-on locking kit	2			
12012.00	Kit tappi per 2 ante (su TT con art.12209.01) Plug kit for 2 wings (to be used with 12209.01)	1	12201.xx	Maniglia interna ad incasso Insert internal handle for locking	2			

GUARNIZIONI
WEATHERSTRIPS

ARTICOLO ITEM	DESCRIZIONE DESCRIPTION	N.	ARTICOLO ITEM	DESCRIZIONE DESCRIPTION	N.	ARTICOLO ITEM	DESCRIZIONE DESCRIPTION	N.
G.0004.EN	Guarnizione esterna ed Interna vetro External and internal weatherstrips on glass	8H - 4L						
G.0000.HA	Guarnizione a spazzolino Protective fiber	6H - 4L						

N.B: - Le dimensioni di taglio e di lavorazione indicate nelle pagine seguenti sono state ottenute considerando le quote teoriche.
 Pertanto è necessario verificare sempre le dimensioni dei profilati prima di effettuare i tagli.
 Sapa declina ogni responsabilità per errori dovuti al mancato controllo da parte del costruttore.

SEZ. B-B

N.B: - The cutting and processing dimensions, indicated in the following pages, are obtained considering theoretical values.
 It is, therefore, always necessary to check the dimensions of the profiles before executing the cutting.
 Sapa declines any responsibility from errors caused from the missing dimensional check of the carpenter

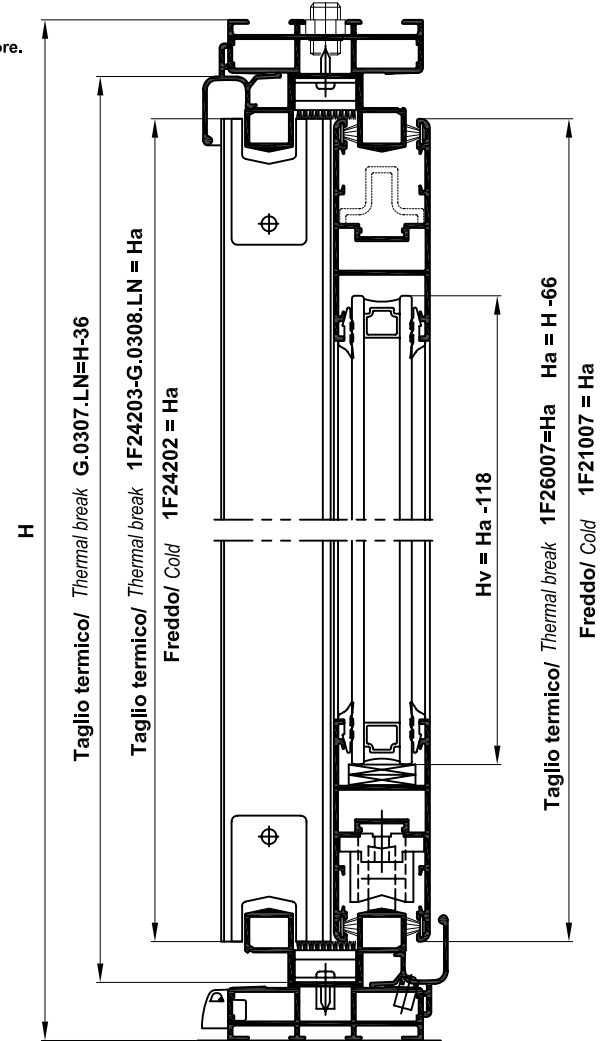
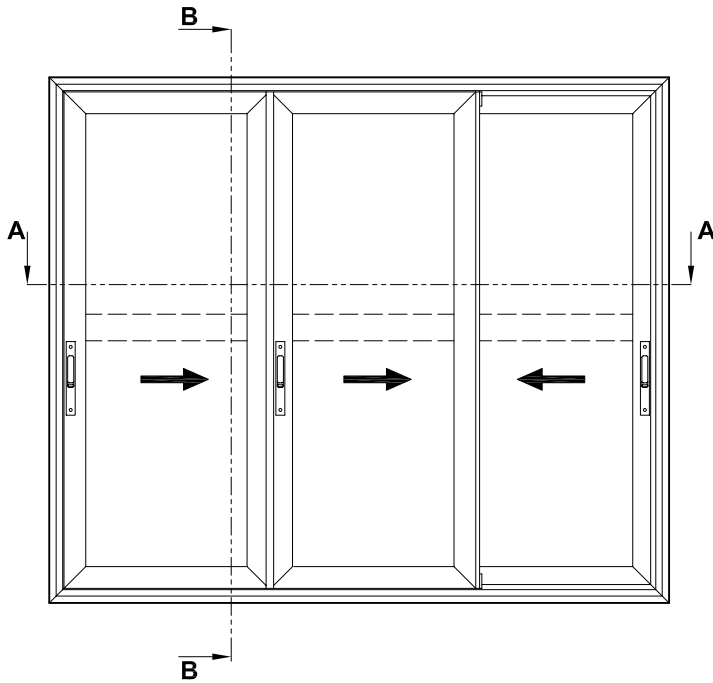

N.B.
 Spessore vetro considerato 20mm
 Gioco perimetrale tra profilato in alluminio e vetro 7mm
 For glass with 20mm thickness
 Space between glass and aluminium section 7mm

SEZ. A-A

Taglio termico/ Thermal break G.0307.LN = L -36

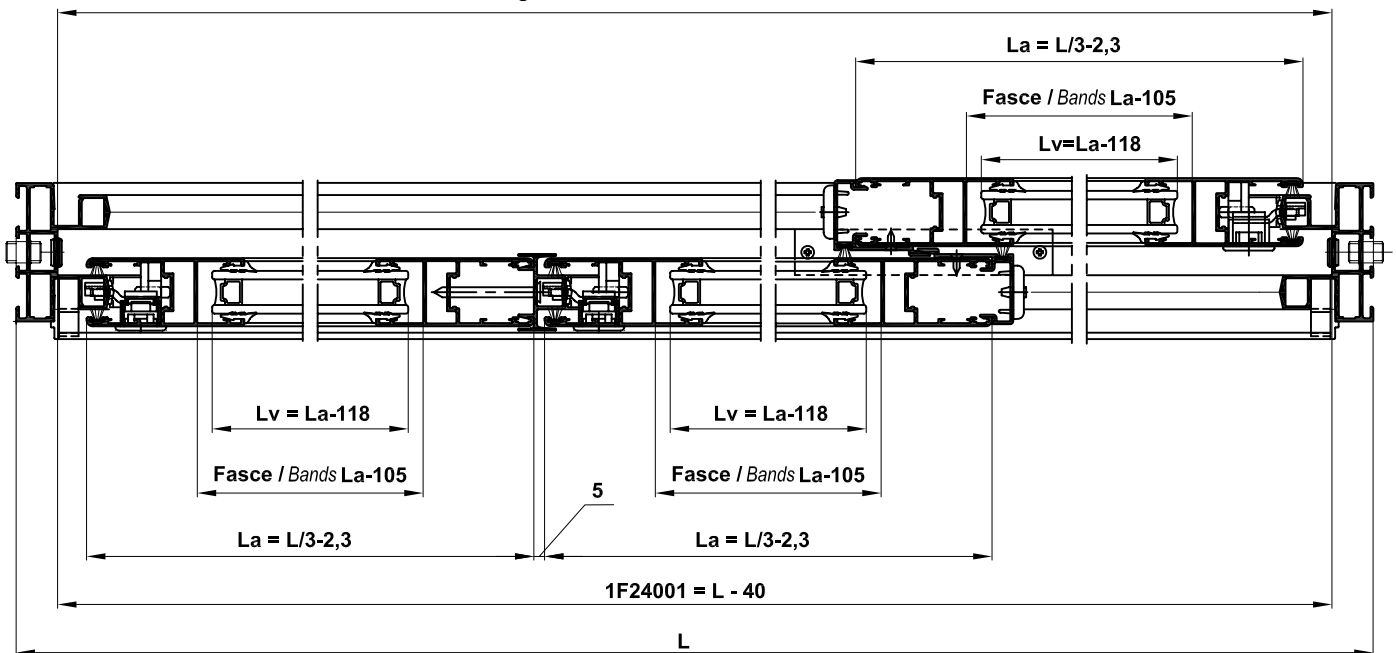

PROFILATO SECTION		N.Pz N.Pz	TAGLIO CUT	N.Pz N.Pz	TAGLIO CUT
		2		2	
		6		6	
		2			
		2			
		2	 Si consiglia di tagliarlo unitamente all'1F26001 We suggest to cut it together with 1F26001	2	 Si consiglia di tagliarlo unitamente all'1F26001 We suggest to cut it together with 1F26001
				2	
				3	
		1			

ACCESSORI WIN65TT / FREDDO
ACCESSORIES WIN65TT / COLD

ARTICOLO ITEM	DESCRIZIONE DESCRIPTION	N.	ARTICOLO ITEM	DESCRIZIONE DESCRIPTION	N.	ARTICOLO ITEM	DESCRIZIONE DESCRIPTION	N.
10040.01	Squadretta allineamento aletta Alignment corner joint on fin	48	10403.00	Basetta per regolo mobile in alluminio Aluminium plate for adjustable fixing	8	12027.00	Piastrina antisollevamento 3° ante 3th door non-lifting plate	1
10026.00	Squadretta ad avvitare (telalo) Corner joint to be screwed (frame)	8	10410.00	Grano per regolo mobile Dowel for adjustable fixing	8			
12210.00	Squadretta ad avvitare (anta) Corner joint to be screwed (leaf)	12	10535.01	Tappo copriforo Ø 12mm Hole plug Ø 12mm	8			
12209.01	Squadretta ad avvitare (anta TT) Corner joint to be screwed (TT leaf)	12	Comm.le	Tasselli spessoramento vetro Glass registration dolly	12			
10003.00	Varianti: squadretta a cianfrinare (anta TT) Alternative: to be crimped corner joint (TT leaf)	24	12021.01	Tappi per gocciolatoio e raccoglicondensa (coppia) Drip channel and drip condensation plugs (pair)	2			
12003.00	Kit 4 carrelli registrabili 4 adjustable double rollers kit	2	12031.01	Kit valvola scarico acqua Water drain valve kit	2			
12011.00	Kit tappi per 2 ante (su TT con art.10003.00) Plug kit for 2 wings (to be used with 10003.00)	2	12054.00	Kit aggancio chiusura ad incasso Recessed clip-on locking kit	3			
12012.00	Kit tappi per 2 ante (su TT con art.12209.01) Plug kit for 2 wings (to be used with 12209.01)	2	12201.xx	Maniglia interna ad incasso Insert internal handle for locking	3			

GUARNIZIONI
WEATHERSTRIPS

ARTICOLO ITEM	DESCRIZIONE DESCRIPTION	N.	ARTICOLO ITEM	DESCRIZIONE DESCRIPTION	N.	ARTICOLO ITEM	DESCRIZIONE DESCRIPTION	N.
G.0004.EN	Guarnizione esterna ed interna vetro External and internal weatherstrips on glass	12H - 4L						
G.0000.HA	Guarnizione a spazzolino Protective fiber	8H - 4L						

N.B.: - Le dimensioni di taglio e di lavorazione indicate nelle pagine seguenti sono state ottenute considerando le quote teoriche.
 Pertanto è necessario verificare sempre le dimensioni dei profilati prima di effettuare i tagli.
 Sapa declina ogni responsabilità per errori dovuti al mancato controllo da parte del costruttore.

N.B.: - The cutting and processing dimensions, indicated in the following pages, are obtained considering theoretical values.
 It is, therefore, always necessary to check the dimensions of the profiles before executing the cutting.
 Sapa declines any responsibility from errors caused from the missing dimensional check of the carpenter

SEZ. B-B

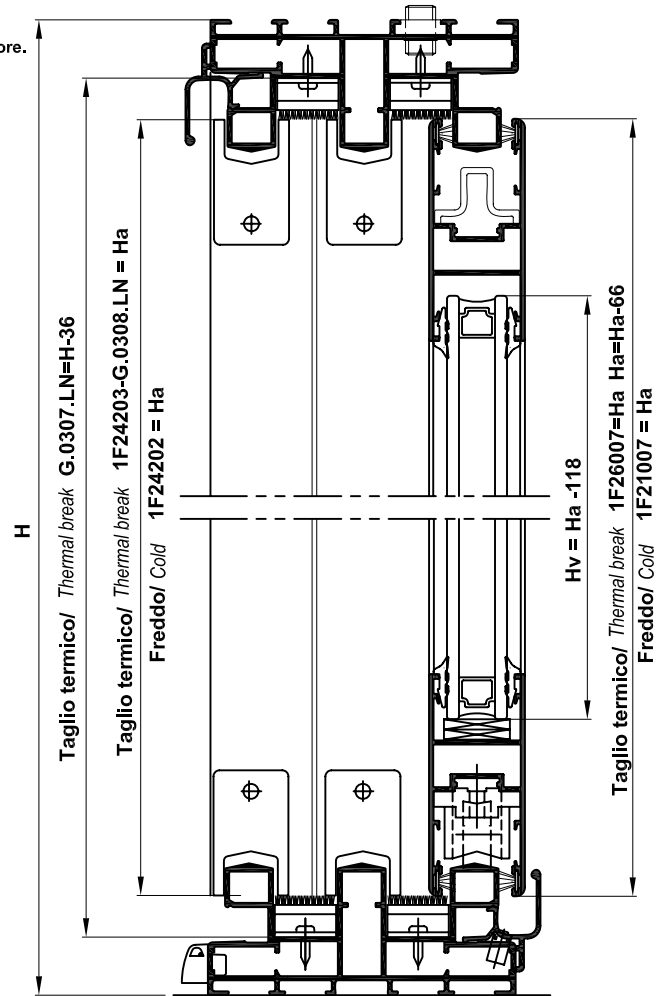
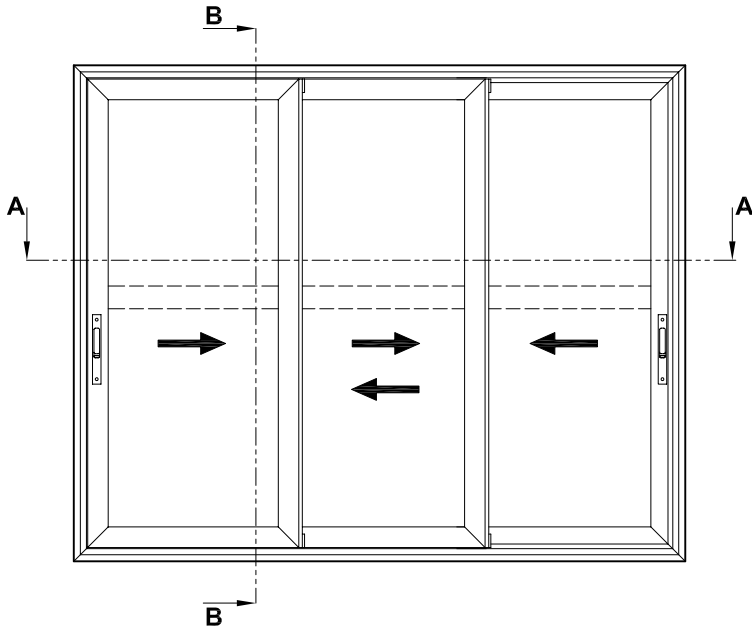







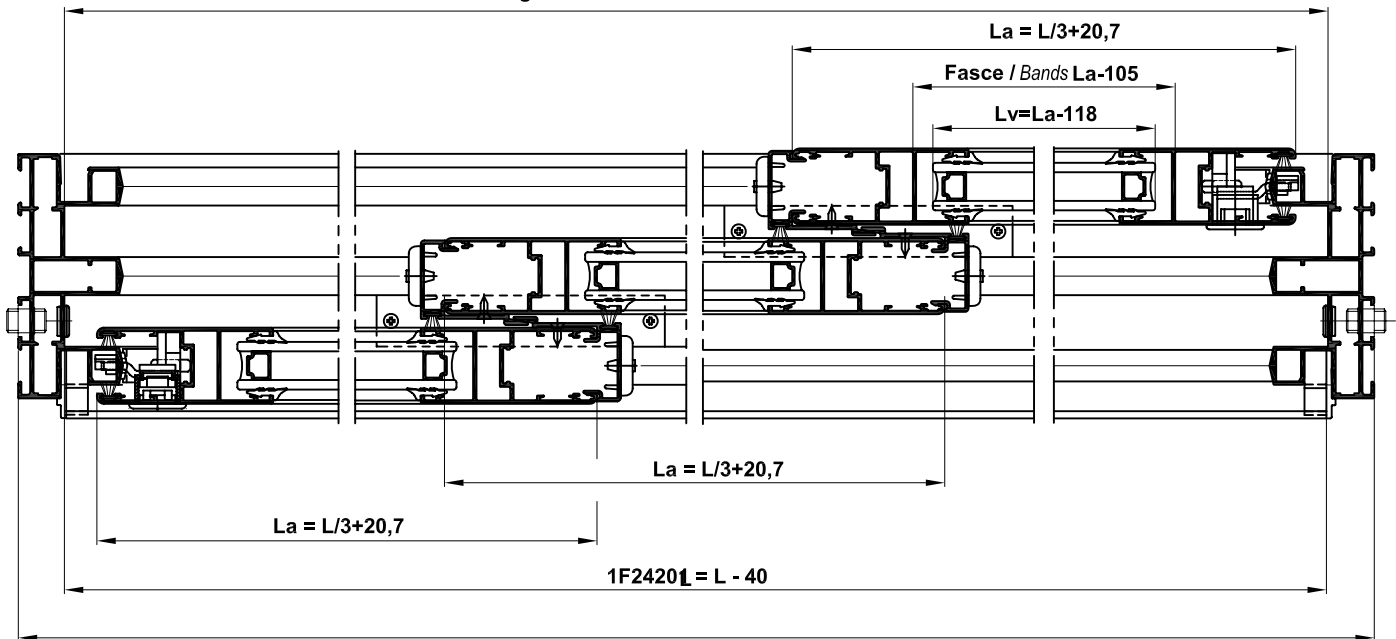





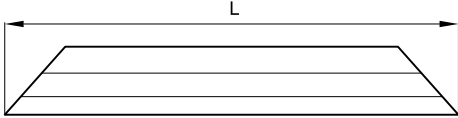

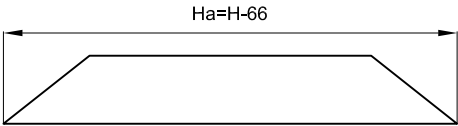
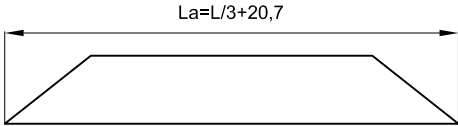

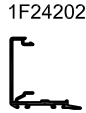
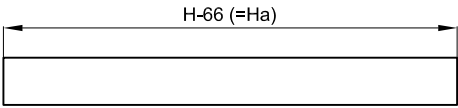
N.B.
 Spessore vetro considerato 20mm
 Glaco perimetrale tra profilato in alluminio e vetro 7mm
 For glass with 20mm thickness
 Space between glass and aluminium section 7mm

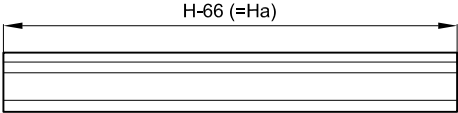
SEZ. A-A

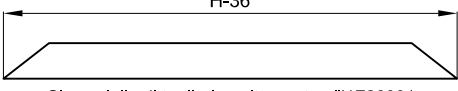
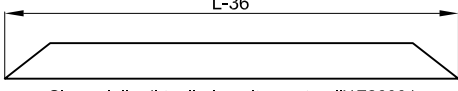
Taglio termico/ Thermal break G.0307.LN = L -36

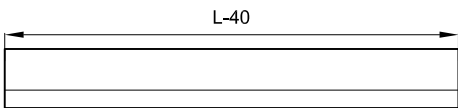

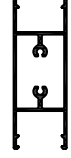
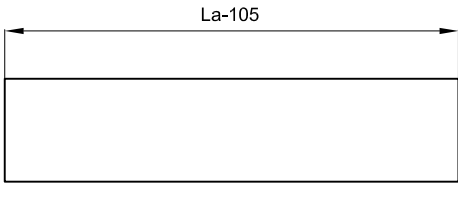
PROFILATO SECTION		N.Pz N.Pz	TAGLIO CUT	N.Pz N.Pz	TAGLIO CUT
					
1F26002 	1F21002 	2		2	
1F26012 	1F21012 	6		6	
1F24203 	1F24202 	4			
G.0308.LN 		4			
G.0307.LN 		4	 Si consiglia di tagliarlo unitamente all'1F26001 We suggest to cut it together with 1F26001	4	 Si consiglia di tagliarlo unitamente all'1F26001 We suggest to cut it together with 1F26001
1F24201 	1F24201 			2	
1F26017 	1F21017 			3	

ACCESSORI WIN65TT / FREDDO
ACCESSORIES WIN65TT / COLD

ARTICOLO ITEM	DESCRIZIONE DESCRIPTION	N.	ARTICOLO ITEM	DESCRIZIONE DESCRIPTION	N.	ARTICOLO ITEM	DESCRIZIONE DESCRIPTION	N.
10040.01	Squadretta allineamento aletta Alignment corner joint on fin	48	10403.00	Basetta per regolo mobile in alluminio Aluminium plate for adjustable fixing	8			
10026.00	Squadretta ad avvitare (telalo) Corner joint to be screwed (frame)	8	10410.00	Grano per regolo mobile Dowel for adjustable fixing	8			
12210.00	Squadretta ad avvitare (anta) Corner joint to be screwed (leaf)	12	10535.01	Tappo copriforo Ø 12mm Hole plug Ø 12mm	8			
12209.01	Squadretta ad avvitare (anta TT) Corner joint to be screwed (TT leaf)	12	Comm.le	Tasselli spessoramento vetro Glass registration dolly	12			
10003.00	Varianti: squadretta a cianfrinare (anta TT) Alternative: to be crimped corner joint (TT leaf)	24	12021.01	Tappi per gocciolatoio e raccogli-condensa (coppia) Drip channel and drip condensation plugs (pair)	2			
12003.00	Kit 4 carrelli regolabili 4 adjustable double rollers kit	2	12031.01	Kit valvola scarico acqua Water drain valve kit	3			
12011.00	Kit tappi per 2 ante (su TT con art.10003.00) Plug kit for 2 wings (to be used with 10003.00)	2	12054.00	Kit aggancio chiusura ad incasso Recessed clip-on locking kit	3			
12012.00	Kit tappi per 2 ante (su TT con art.12209.01) Plug kit for 2 wings (to be used with 12209.01)	2	12201.xx	Maniglia interna ad incasso Insert internal handle for locking	3			

GUARNIZIONI
WEATHERSTRIPS

ARTICOLO ITEM	DESCRIZIONE DESCRIPTION	N.	ARTICOLO ITEM	DESCRIZIONE DESCRIPTION	N.	ARTICOLO ITEM	DESCRIZIONE DESCRIPTION	N.
G.0004.EN	Guarnizione esterna ed interna vetro External and internal weatherstrips on glass	12H - 4L						
G.0000.HA	Guarnizione a spazzolino Protective fiber	8H - 4L						

N.B: - Le dimensioni di taglio e di lavorazione indicate nelle pagine seguenti sono state ottenute considerando le quote teoriche.
 Pertanto è necessario verificare sempre le dimensioni dei profilati prima di effettuare i tagli.
 Sapa declina ogni responsabilità per errori dovuti al mancato controllo da parte del costruttore.

SEZ. B-B

N.B: - The cutting and processing dimensions, indicated in the following pages, are obtained considering theoretical values.
 It is, therefore, always necessary to check the dimensions of the profiles before executing the cutting.
 Sapa declines any responsibility from errors caused from the missing dimensional check of the carpenter

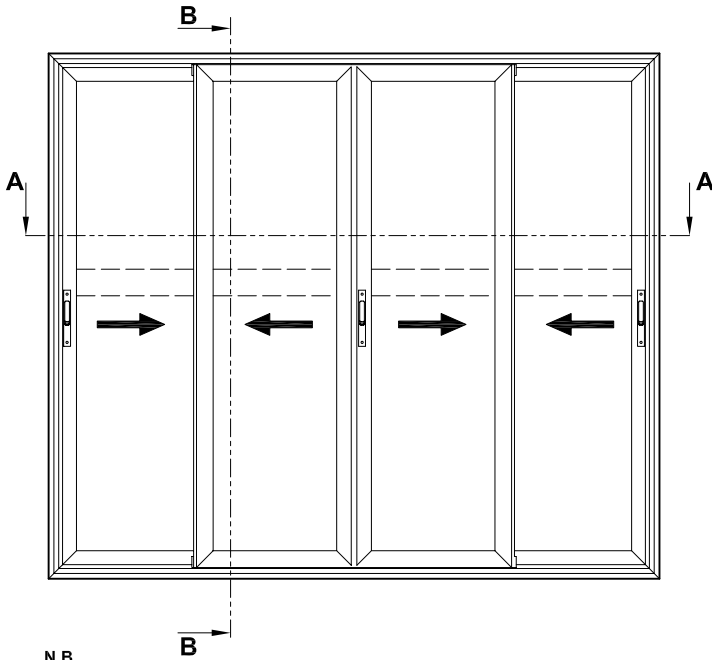

N.B.
 Spessore vetro considerato 20mm
 Gioco perimetrale tra profilato in alluminio e vetro 7mm
 For glass with 20mm thickness
 Space between glass and aluminium section 7mm

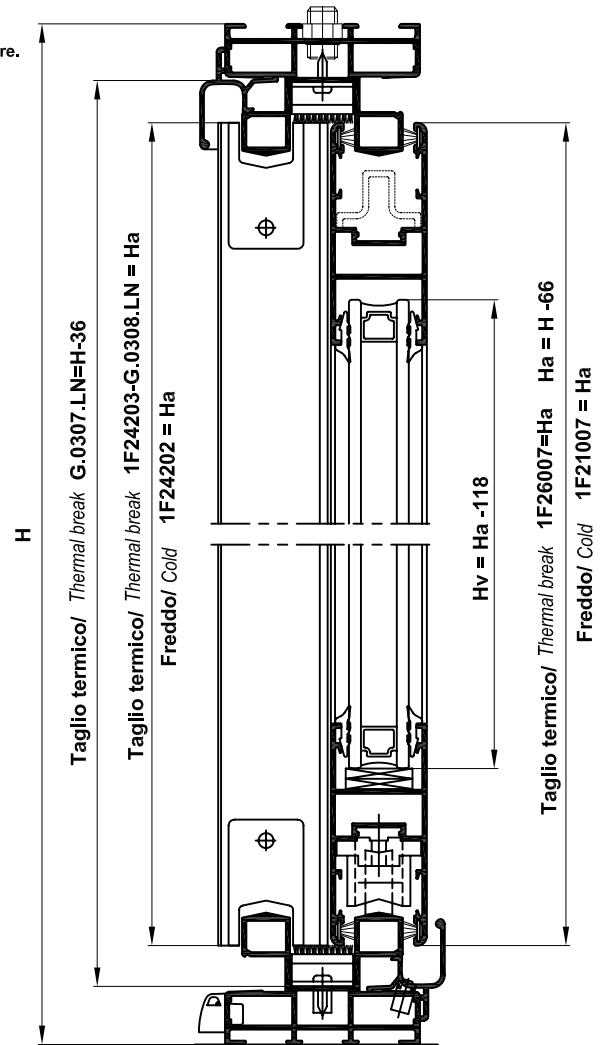

SEZ. A-A

Taglio termico / Thermal break G.0307.LN = L - 36

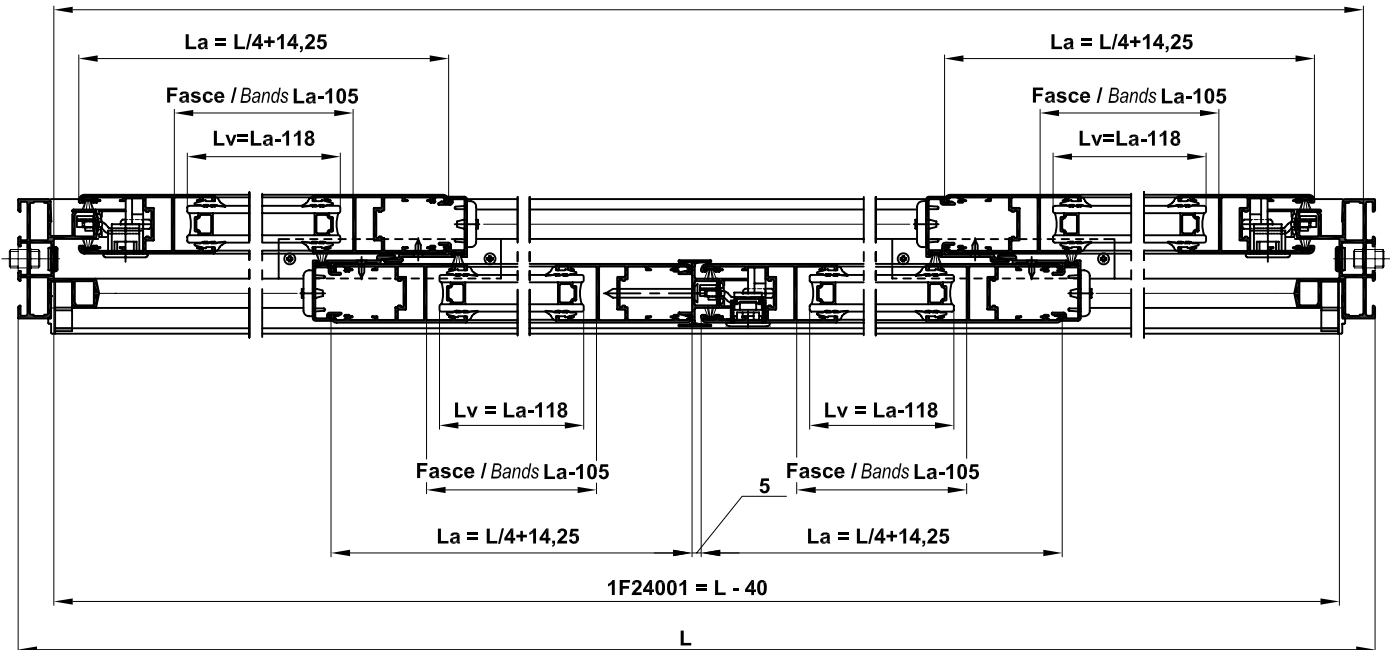

PROFILATO SECTION		N.Pz N.Pz	TAGLIO CUT	N.Pz N.Pz	TAGLIO CUT
		2		2	
		8		8	
		4			
		4			
		2	 Si consiglia di tagliarlo unitamente all'1F26001 We suggest to cut it together with 1F26001	2	 Si consiglia di tagliarlo unitamente all'1F26001 We suggest to cut it together with 1F26001
				2	
				4	
		1			

ACCESSORI WIN65TT / FREDDO
ACCESSORIES WIN65TT / COLD

ARTICOLO ITEM	DESCRIZIONE DESCRIPTION	N.	ARTICOLO ITEM	DESCRIZIONE DESCRIPTION	N.	ARTICOLO ITEM	DESCRIZIONE DESCRIPTION	N.
10040.01	Squadretta allineamento aletta Alignment corner joint on fin	64	10403.00	Basetta per regolo mobile in alluminio Aluminium plate for adjustable fixing	10	12027.00	Piastrina antisollevamento 4 ^a ante 4th door non-lifting plate	1
10026.00	Squadretta ad avvitare (telalo) Corner joint to be screwed (frame)	8	10410.00	Grano per regolo mobile Dowel for adjustable fixing	10			
12210.00	Squadretta ad avvitare (anta) Corner joint to be screwed (leaf)	16	10535.01	Tappo copriforo Ø 12mm Hole plug Ø 12mm	10			
12209.01	Squadretta ad avvitare (anta TT) Corner joint to be screwed (TT leaf)	16	Comm.le	Tasselli spessoramento vetro Glass registration dolly	16			
10003.00	Variante: squadretta a cianfrinare (anta TT) Alternative: to be crimped corner joint (TT leaf)	32	12021.01	Tappi per gocciolatoio e raccoglicondensa (coppia) Drip channel and drip condensation plugs (pair)	2			
12003.00	Kit 4 carrelli registrabili 4 adjustable double rollers kit	2	12031.01	Kit valvola scarico acqua Water drain valve kit	2			
12011.00	Kit tappi per 2 ante (su TT con art.10003.00) Plug kit for 2 wings (to be used with 10003.00)	2	12054.00	Kit aggancio chiusura ad incasso Recessed clip-on locking kit	3			
12012.00	Kit tappi per 2 ante (su TT con art.12209.01) Plug kit for 2 wings (to be used with 12209.01)	2	12201.xx	Maniglia interna ad incasso Insert internal handle for locking	3			

GUARNIZIONI
WEATHERSTRIPS

ARTICOLO ITEM	DESCRIZIONE DESCRIPTION	N.	ARTICOLO ITEM	DESCRIZIONE DESCRIPTION	N.	ARTICOLO ITEM	DESCRIZIONE DESCRIPTION	N.
G.0004.EN	Guarnizione esterna ed interna vetro External and internal weatherstrips on glass	16H - 4L						
G.0000.HA	Guarnizione a spazzolino Protective fiber	10H - 4L						

SQUADRETTE AD AVVITARE
CORNER JOINTS TO BE SCREWED

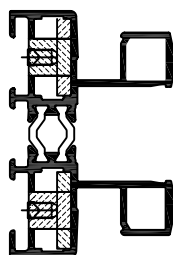
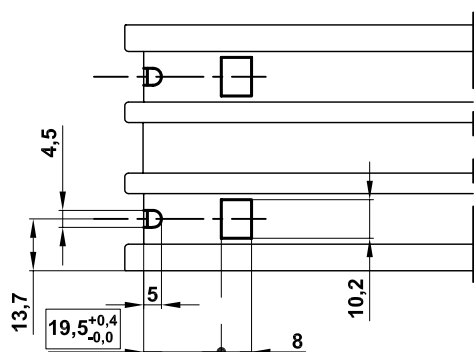

1F26001 / 1F21001

WIN 65s^{TT}
SYSTEM

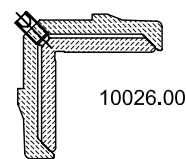

10026.00

Attrezzatura: PUNZONATRICE
Tooling: PUNCHING MACHINE

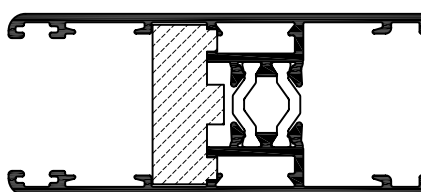
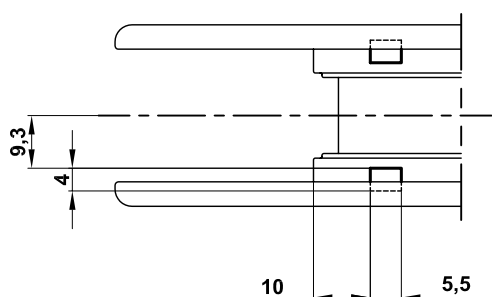

1F26012 / 1F26015

WIN 65s^{TT}
SYSTEM

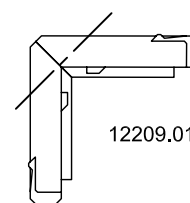

12209.01

Attrezzatura: PUNZONATRICE
Tooling: PUNCHING MACHINE

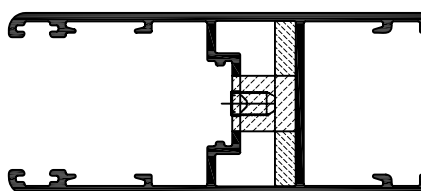
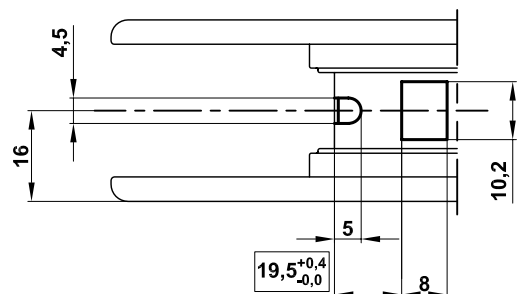

1F21012 / 1F21015

WIN 65s
SYSTEM

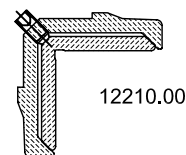

12210.00

Attrezzatura: PUNZONATRICE
Tooling: PUNCHING MACHINE

SQUADRETTE A CIANFRINARE
CORNER JOINTS TO BE CRIMPED

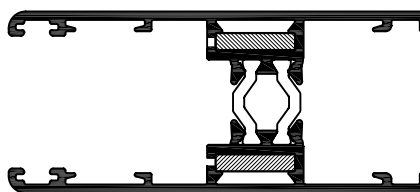
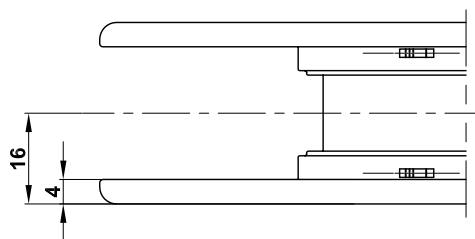

1F26012 / 1F26015

WIN 65s^{TT}
SYSTEM

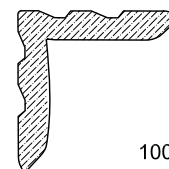

10003.00

Attrezzatura: CIANFRINATRICE
Tooling: CRIMPING MACHINE

INTESTATURA TRAVERSI
TRANSOM BUTTING

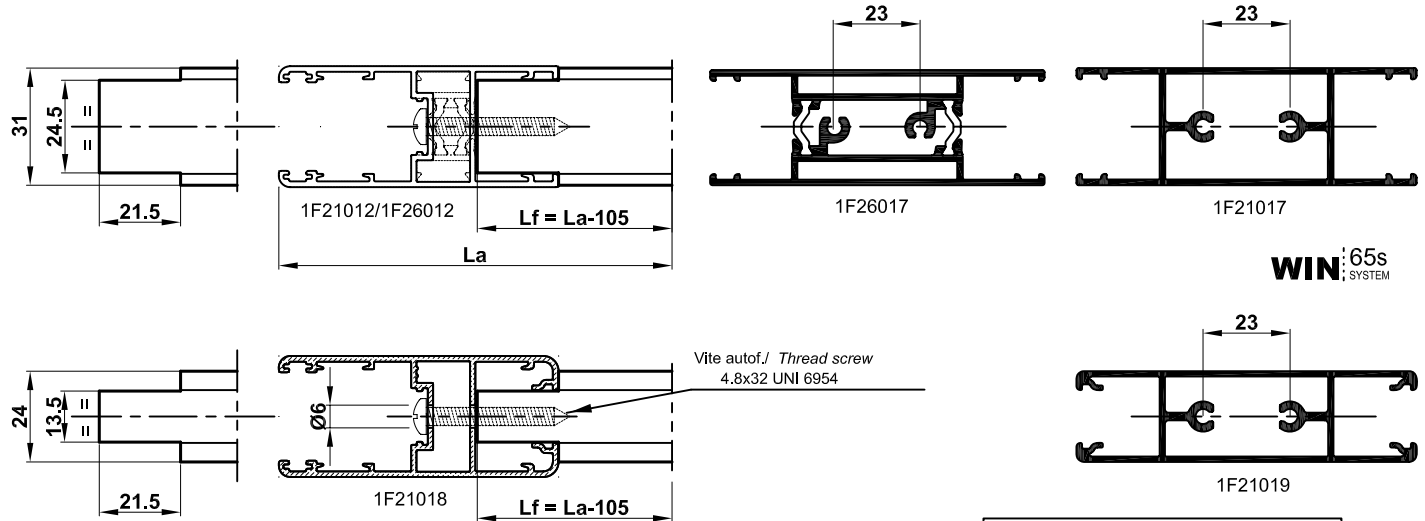

REGOLO MOBILE
ADJUSTABLE FIXING

Attrezzatura: GRUPPO FRESE
Tooling: MILLING CUTTER GROUP

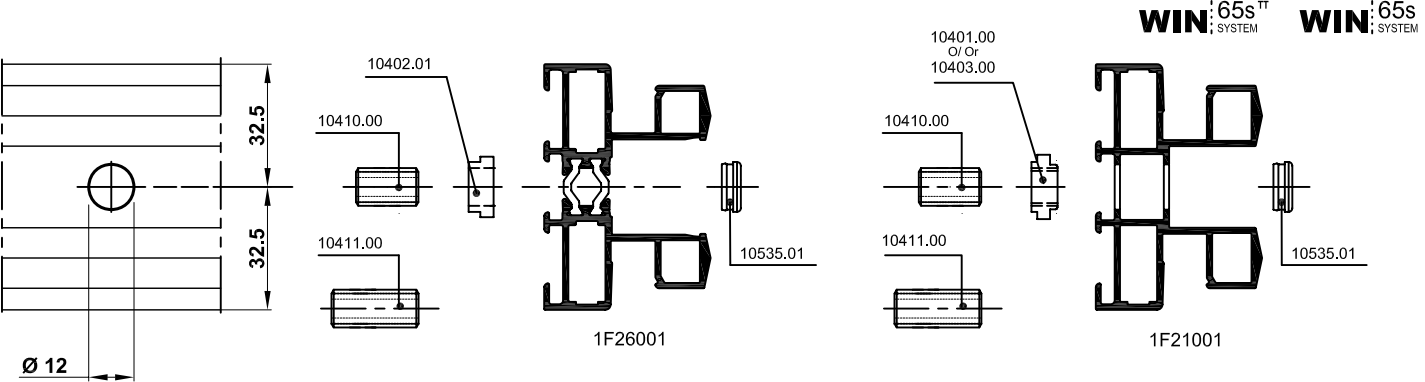

LAVORAZIONI PROFILATI 1F24202 - 1F24203
SECTION PROCESSING 1F24202 - 1F24203

Attrezzatura: TRAPANO
Tooling: DRILL

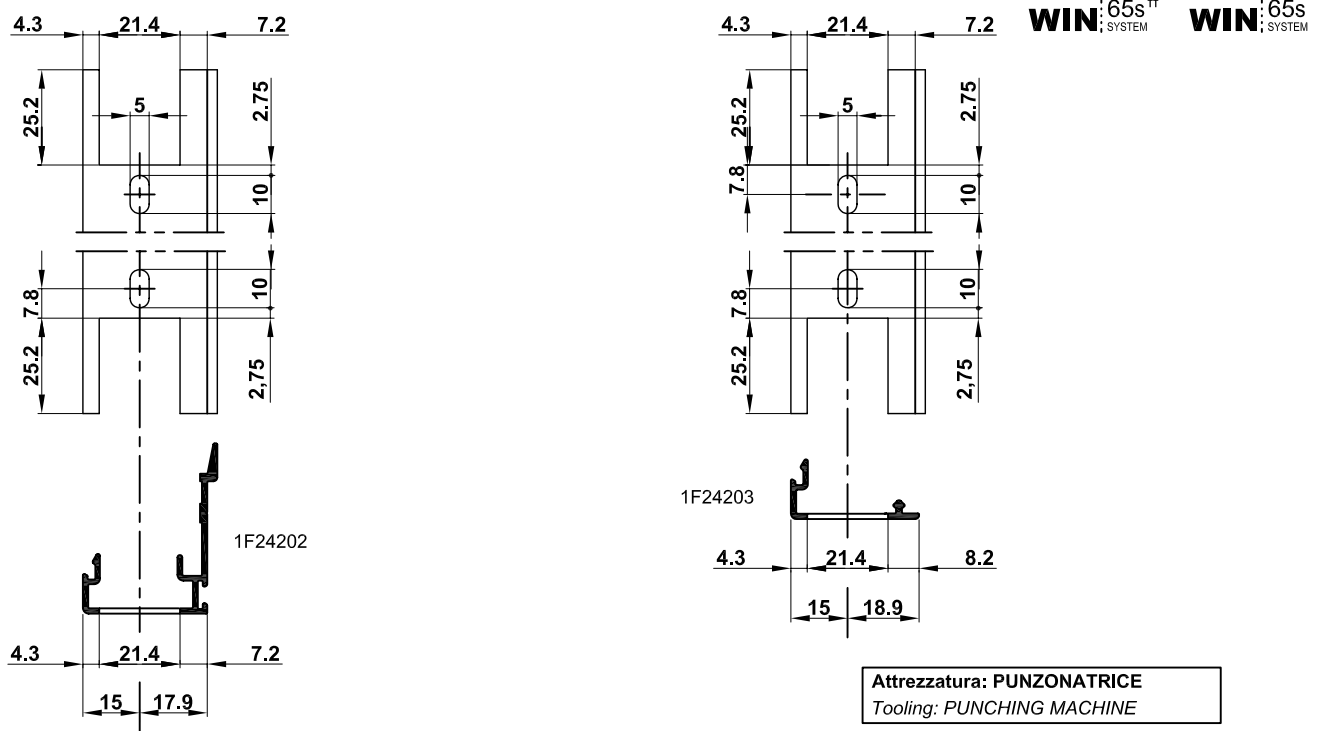

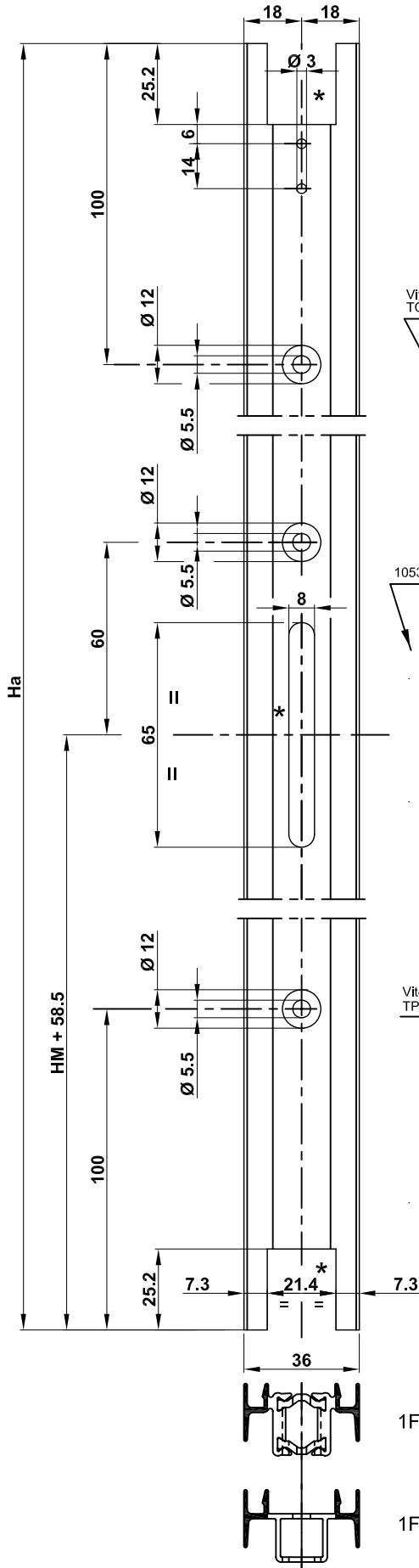

Esempi applicativi
Exsamples of applications

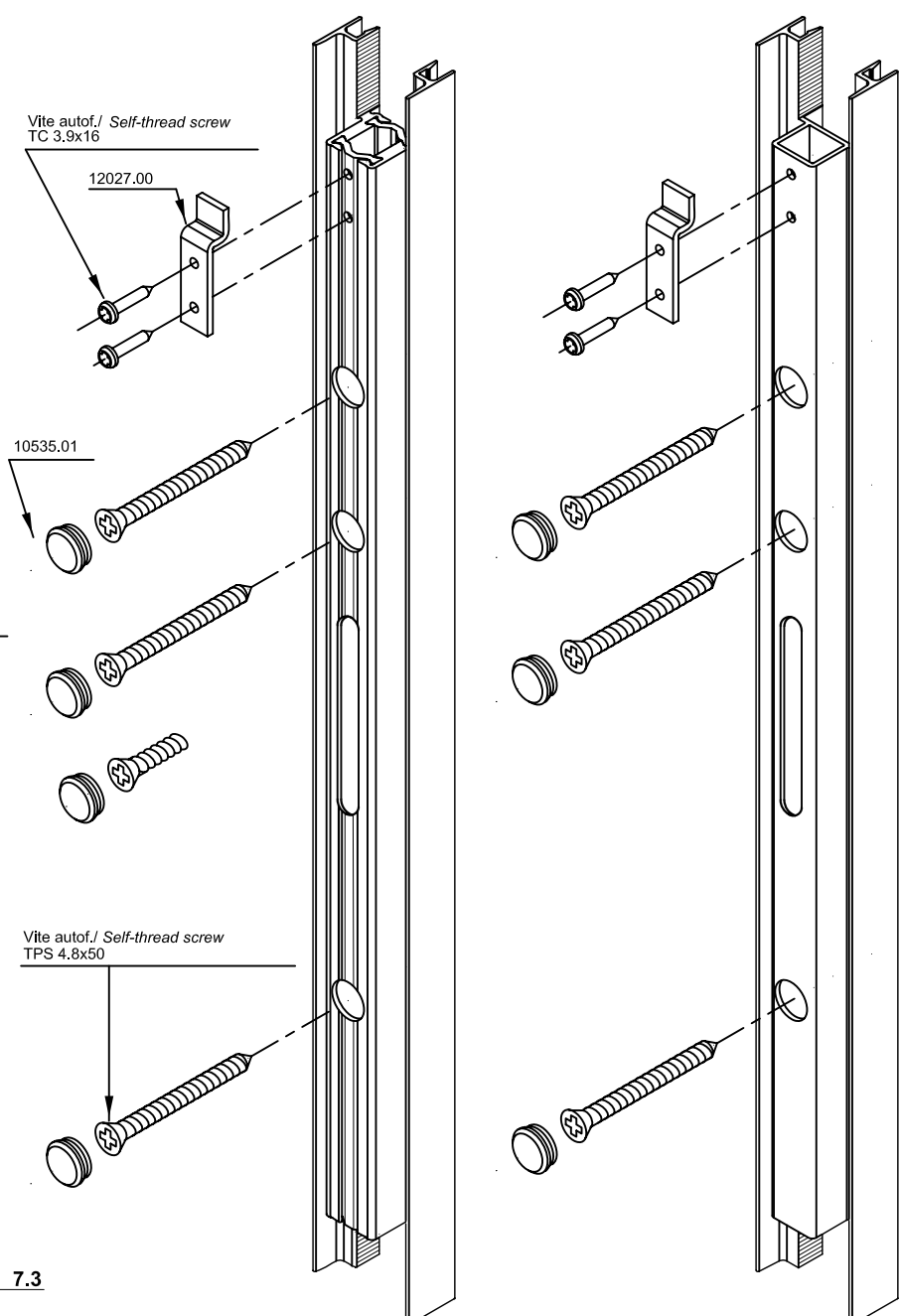

* **Attrezzatura: PANTOGRAFO**
Tooling: PANTOGRAPH

LAVORAZIONI E MONTAGGIO CHIUSURA AD INCASSO
PROCESSING AND MOUNTING EMBEDDED LOCK

Lavorazione profilato telaio
Processing frame section

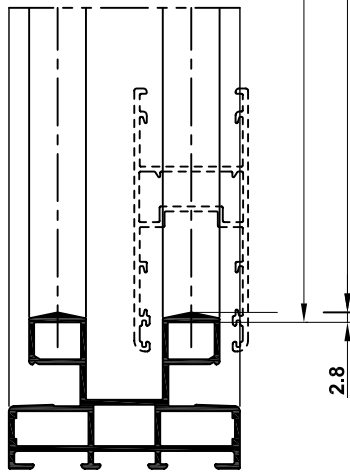
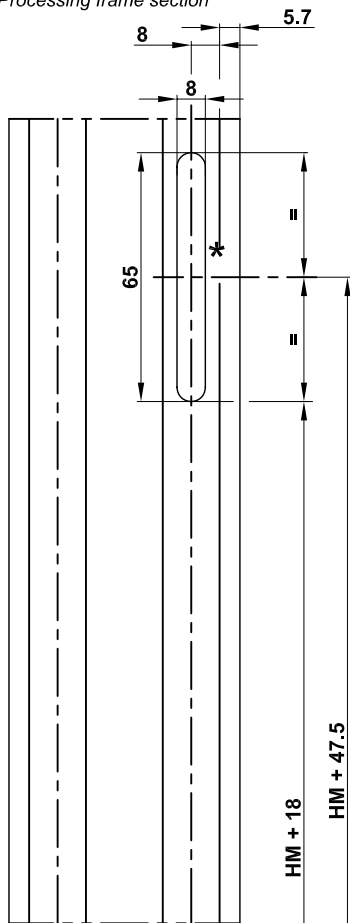

1F21001

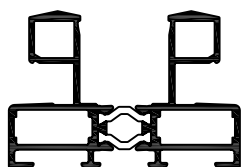

1F26001

Particolari di montaggio riscontro
laterale di chiusura su telaio
Mounting details of lock side
striker plate on frame

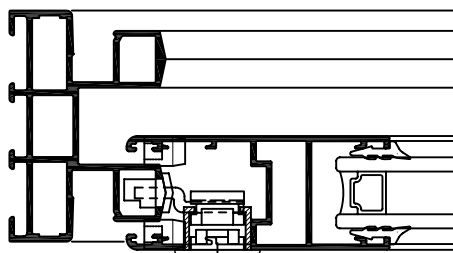
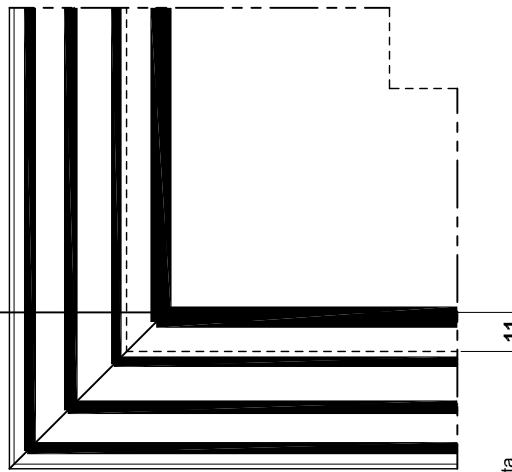
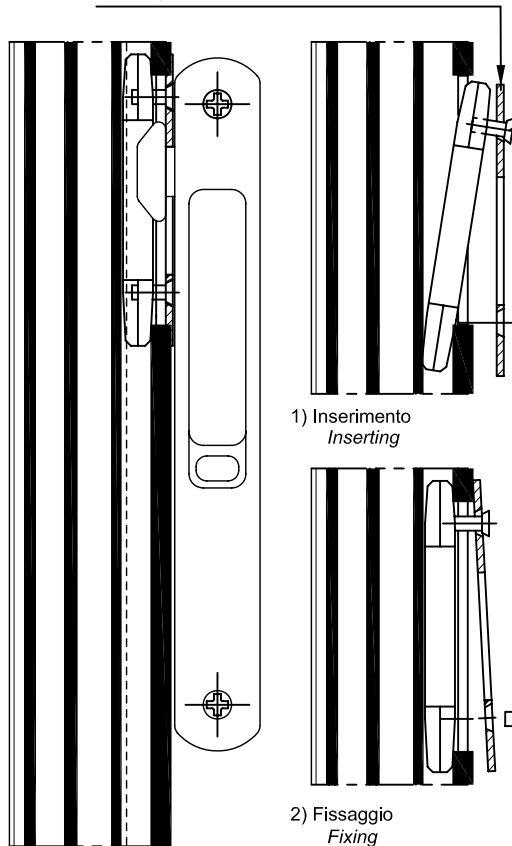

Lavorazione profilato anta
Processing wing section

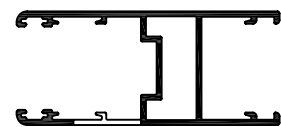
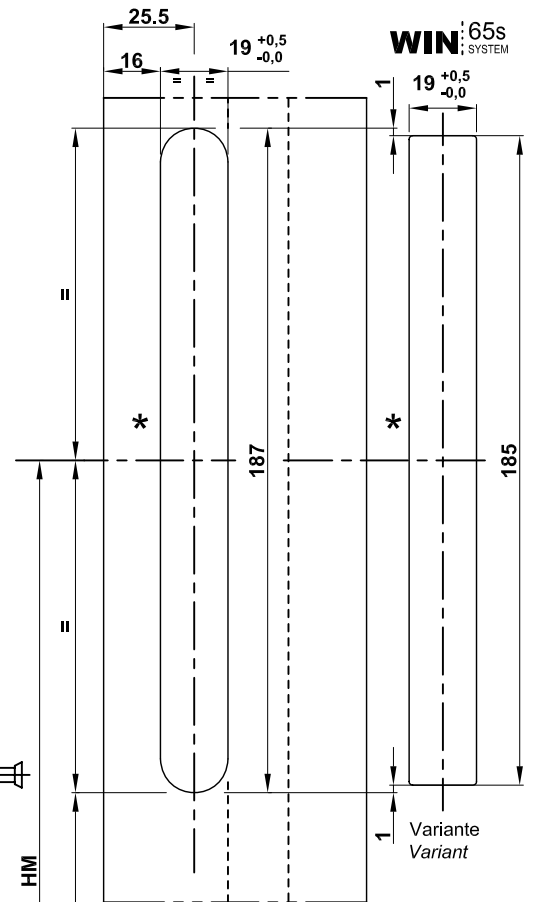

1F21012
1F21015

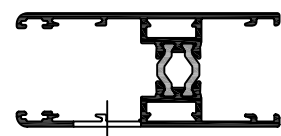

1F26012
1F26015

Filo anta
Wing limit

* **Attrezzatura: PANTOGRAFO**
Tooling: PANTOGRAPH

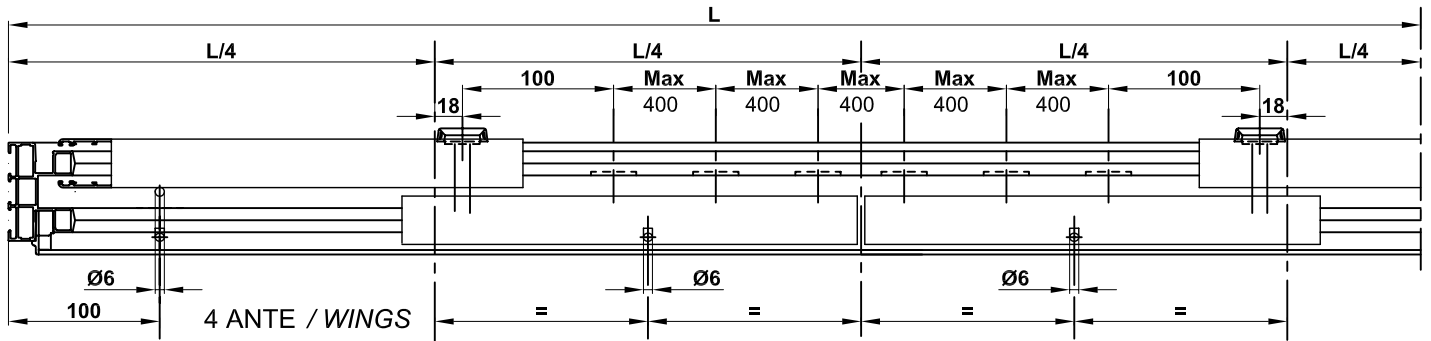
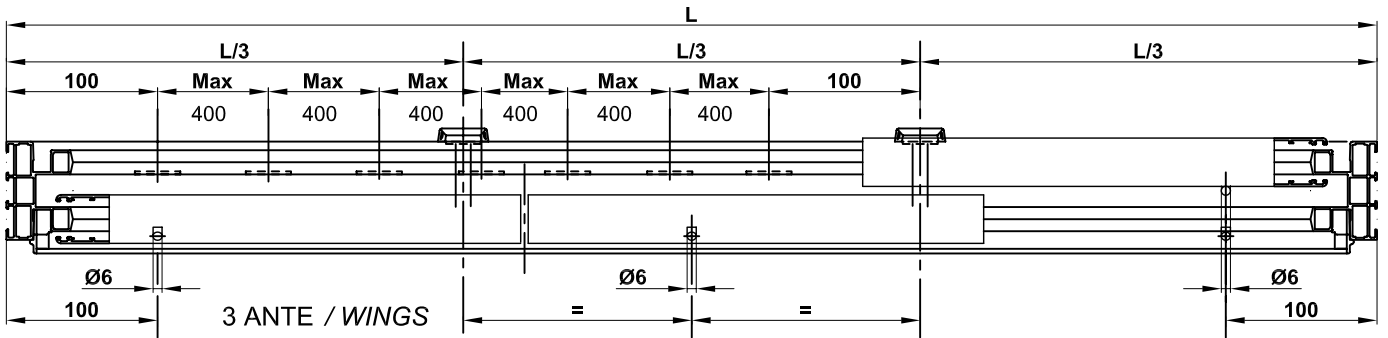
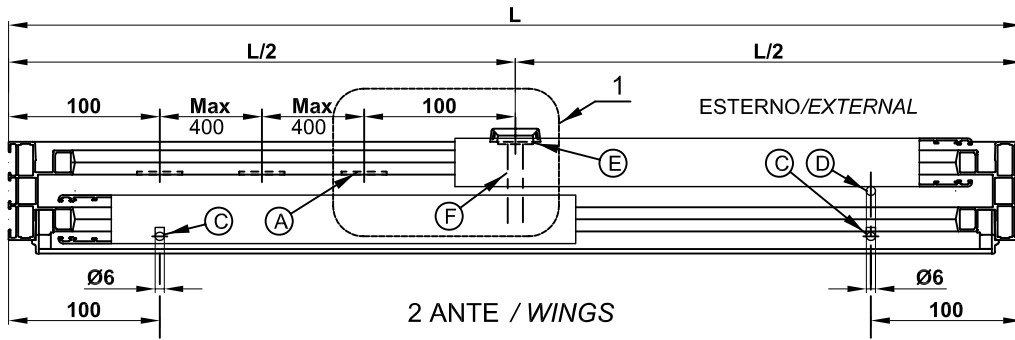

LAVORAZIONI:
PROCESSING:

(A) → Attrezzatura: PUNZONATRICE
Tooling: PUNCHING MACHINE

LAVORAZIONI:
PROCESSING:

(D) (C) (F) → Attrezzatura: TRAPANO
Tooling: DRILL

LAVORAZIONI:
PROCESSING:

(E) → Attrezzatura: PANTOGRAFO
Tooling: PANTOGRAPH

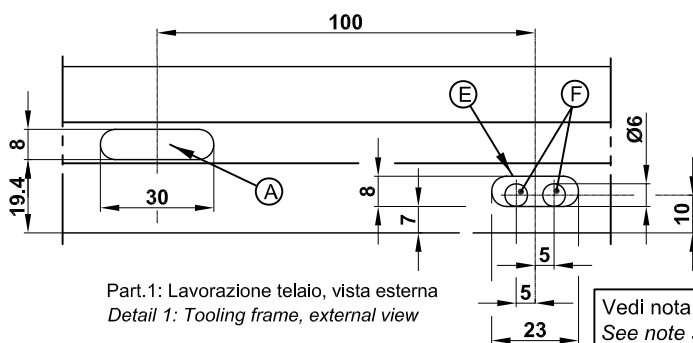

Part.1: Lavorazione telaio, vista esterna
Detail 1: Tooling frame, external view

* Vedi nota sigillatura pag. F8-65s-A.06
See note sealing page F8-65s-A.06

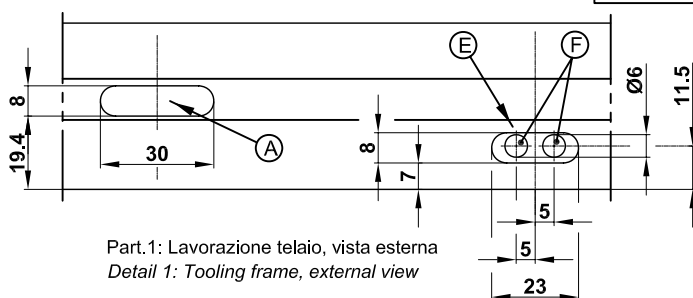

Part.1: Lavorazione telaio, vista esterna
Detail 1: Tooling frame, external view

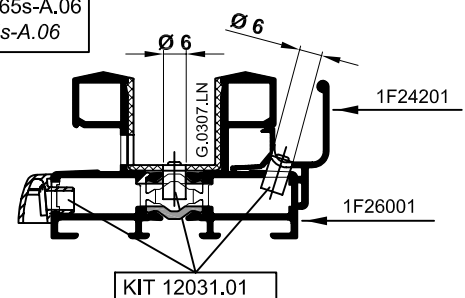
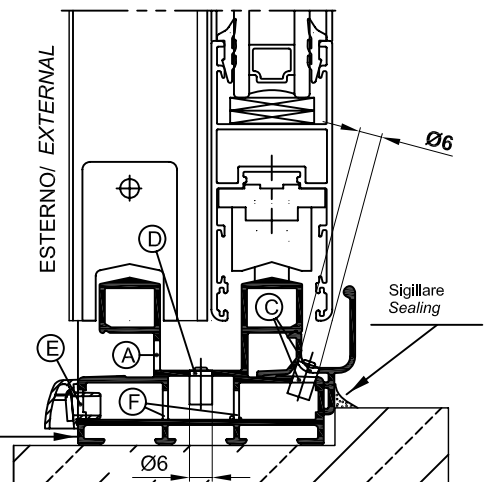

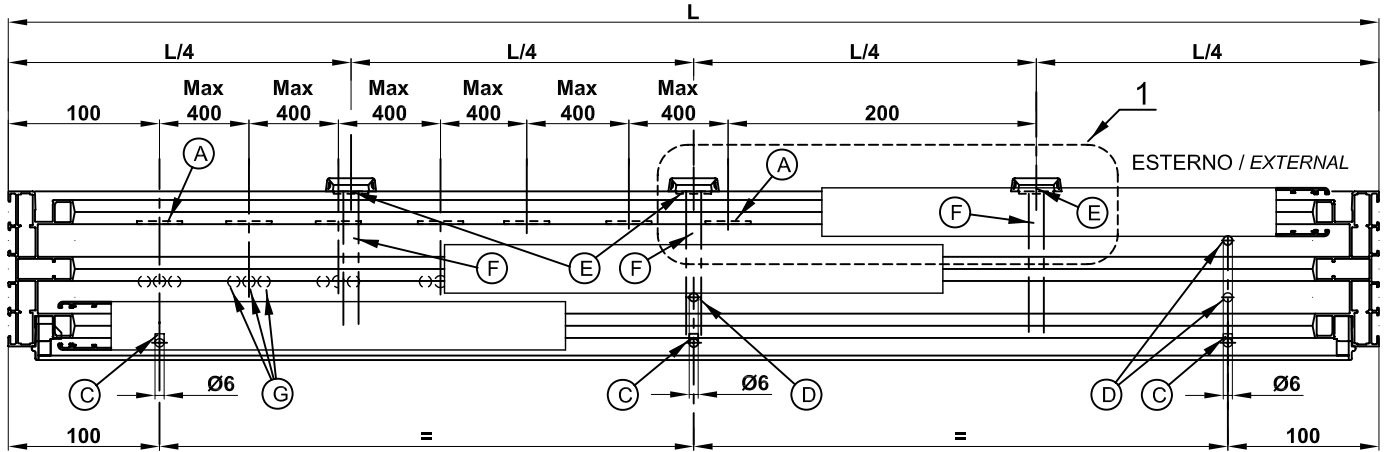

3 ANTE/WINGS

- | | | |
|-----------------------------|-------------|---|
| LAVORAZIONI:
PROCESSING: | (A) | Attrezzatura: PUNZONATRICE
Tooling: PUNCHING MACHINE |
| LAVORAZIONI:
PROCESSING: | (D) (C) (F) | Attrezzatura: TRAPANO
Tooling: DRILL |
| LAVORAZIONI:
PROCESSING: | (E) | Attrezzatura: PANTOGRAFO
Tooling: PANTOGRAPH |

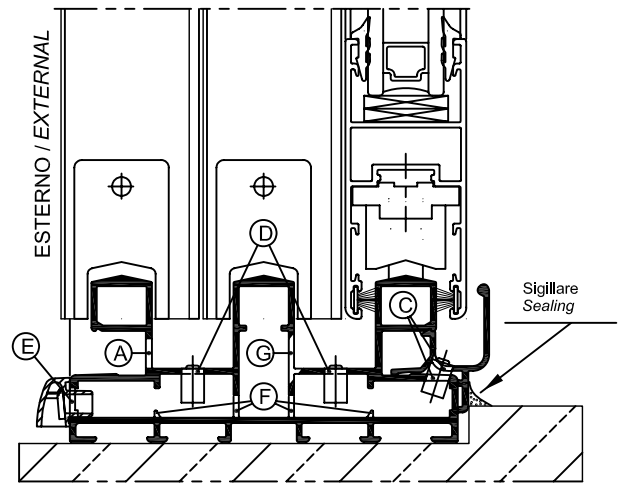
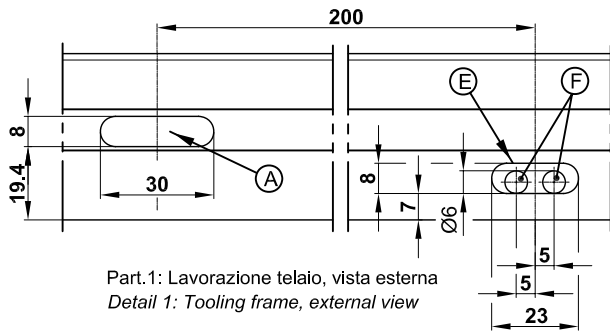

* Raccomandiamo di prestare la **MASSIMA** attenzione alle sigillature del telaio di seguito elencate (già indicate a pag. F1-65s-A.03) per una buona tenuta all'acqua del serramento:

- interno tubolarità, perimetro taglio a 45° e fori tiraggio squadrette telaio 1F21002-1F26002
 - nel punto di contatto del profilato 1F26002 e la G.0307.LN su tutta la larghezza del telaio inferiore
- We recommend to pay **MAXIMUM** attention to the here below listed sealing on the frame (as indicated at page F1-65s-A.03) to guarantee a good water tightness of the window:

- internal tubularity, 45° cut perimeter and corner joints holes on wing 1F21002-1F26002
- at the contact point between the profile 1F26002 and G.0307.LN on the whole length of the lower frame

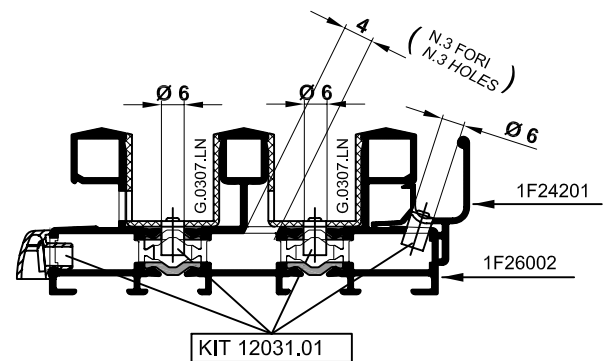
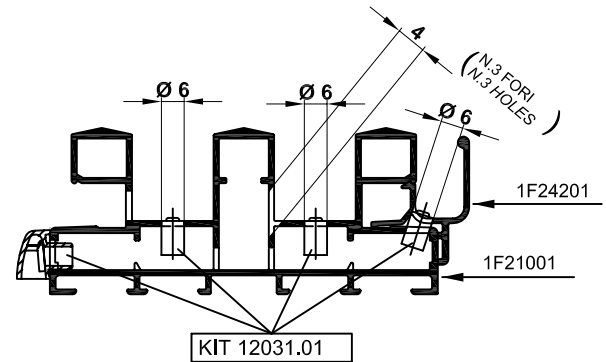
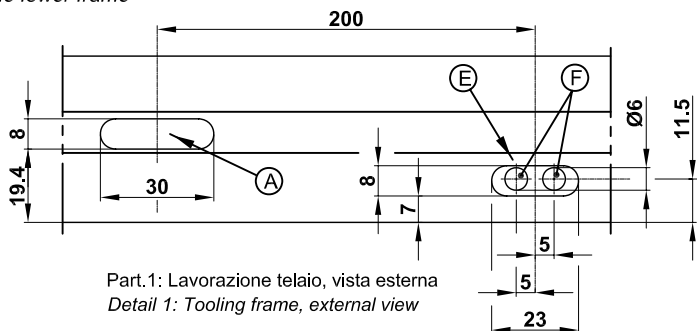

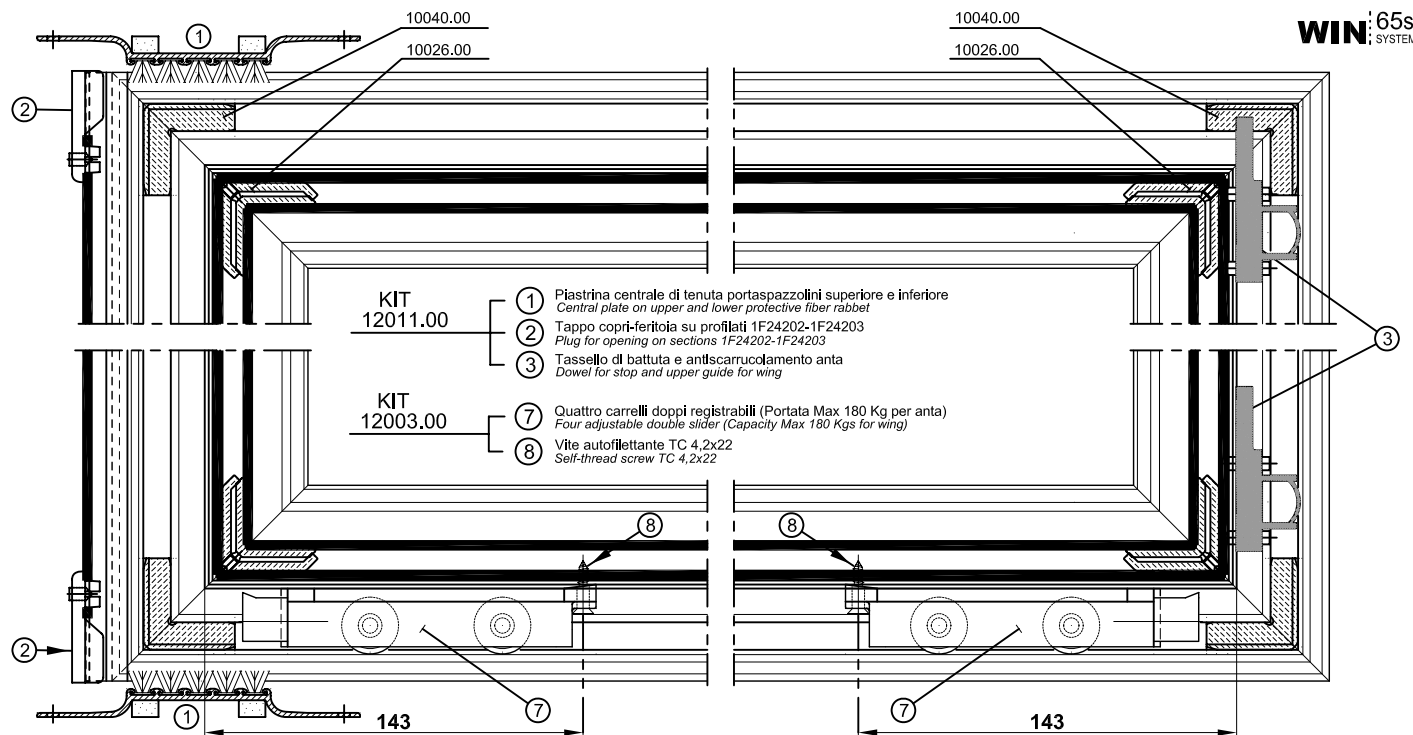

NEL CASO DI UTILIZZO SOLUZIONE "CHIUSURA MULTIPUNTO", ELIMINARE ACCESSORIO N° 3
IF YOU MUST BE USED "MULTIPOINT LOCKED" SOLUTION, NOT TO BE USED ACCESSORIES N°3

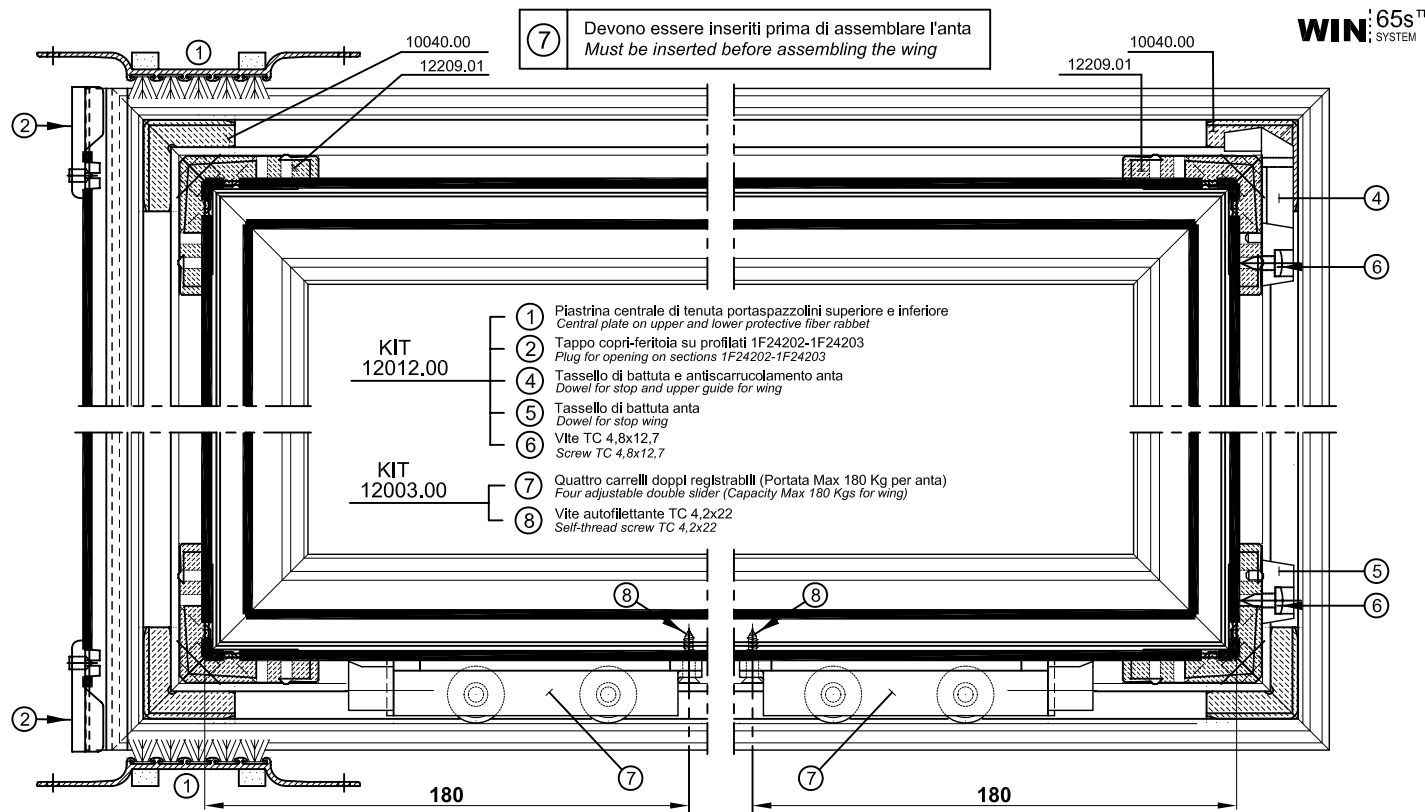

NEL CASO DI UTILIZZO SOLUZIONE "CHIUSURA MULTIPUNTO", ELIMINARE ACCESSORI N° 4 - 5 E 6
IF YOU MUST BE USED "MULTIPOINT LOCKED" SOLUTION, NOT TO BE USED ACCESSORIES N°4 - 5 AND 6

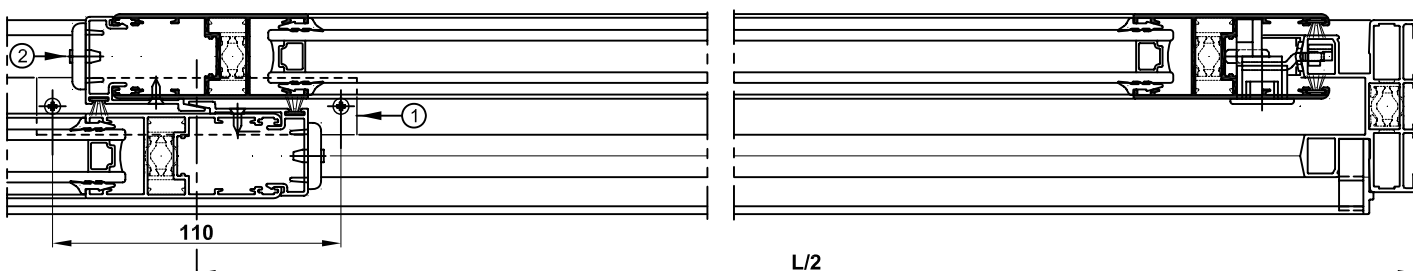

A = DISTANZA PARTE INF.SCORREVOLE-ASSE MANIGLIA **B** = DISTANZA PARTE SUP.SCORREVOLE-ASSE MANIGLIA
TUTTE LE QUOTE E LE MISURE INDICATE SONO ESPRESSE IN mm

1 TAGLI ASTE DI COLLEGAMENTO

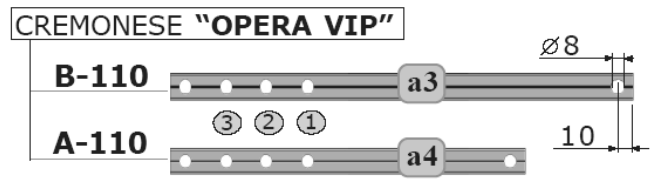
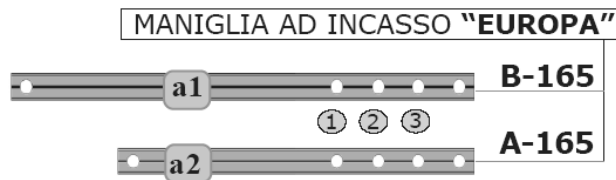

2 LAVORAZIONI SU SCORREVOLE PER INSERIMENTO MANIGLIA

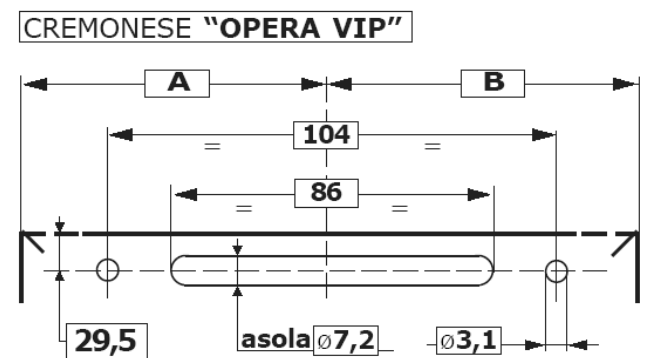
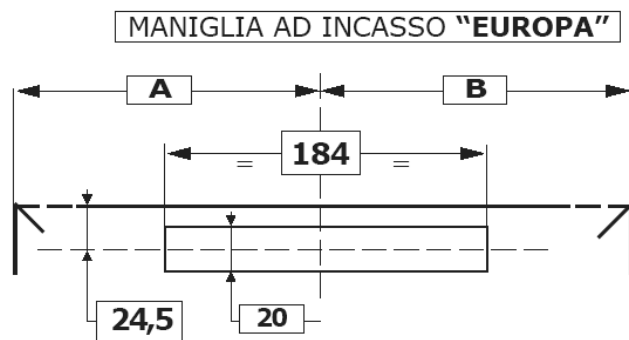

3 INSERIMENTO E FISSAGGIO COMPENSATORI (prima di assemblare l'anta)

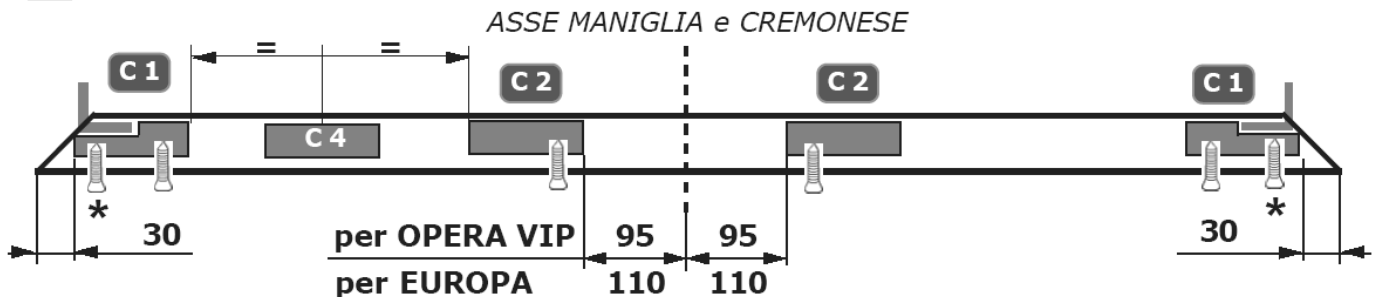

* Viti da fissare utilizzando il foro passante esistente nella squadretta di giunzione.

MANIGLIA AD INCASSO "EUROPA"

- 4** Fissare la maniglia EUROPA allo scorrevole.
- 5** Inserire le aste **a1** e **a2**, assemblando alle estremità, i puntali.
- 6** Fissare, con le viti (M6x14) e le staffe in dotazione, le aste alla maniglia.
- 7** Fissare la terza chiusura **C3** sull'asta **a1**, utilizzando i fori 2 e 3, vedi *tagli aste*. (E' possibile fissare la terza chiusura anche a infisso finito). In questo modo il riscontro a telaio si troverà alla stessa altezza di quello del lato cremonese Opera Vip.

CREMONESE "OPERA VIP"

- 4** Fissare la cremonese OPERA VIP allo scorrevole, inserendo i blocchetti-giunzione.
- 5** Inserire le aste **a3** e **a4**, assemblando alle estremità i puntali.
- 6** Fissare, con i perni e i blocchetti in dotazione, le aste alla cremonese.
- 7** Fissare la terza chiusura **C3** sull'asta **a3**, utilizzando i fori 1 e 2, vedi *tagli aste*. (E' possibile fissare la terza chiusura anche a infisso finito). In questo modo il riscontro a telaio si troverà alla stessa altezza di quello del lato maniglia Europa.

PER IL MONTAGGIO DEGLI ACCESSORI NON INDICATI VEDI PAG. F8-65s-B.01
FOR ACCESSORY MOUNTING NOT INDICATED SEE PAG. F8-65s-B.01

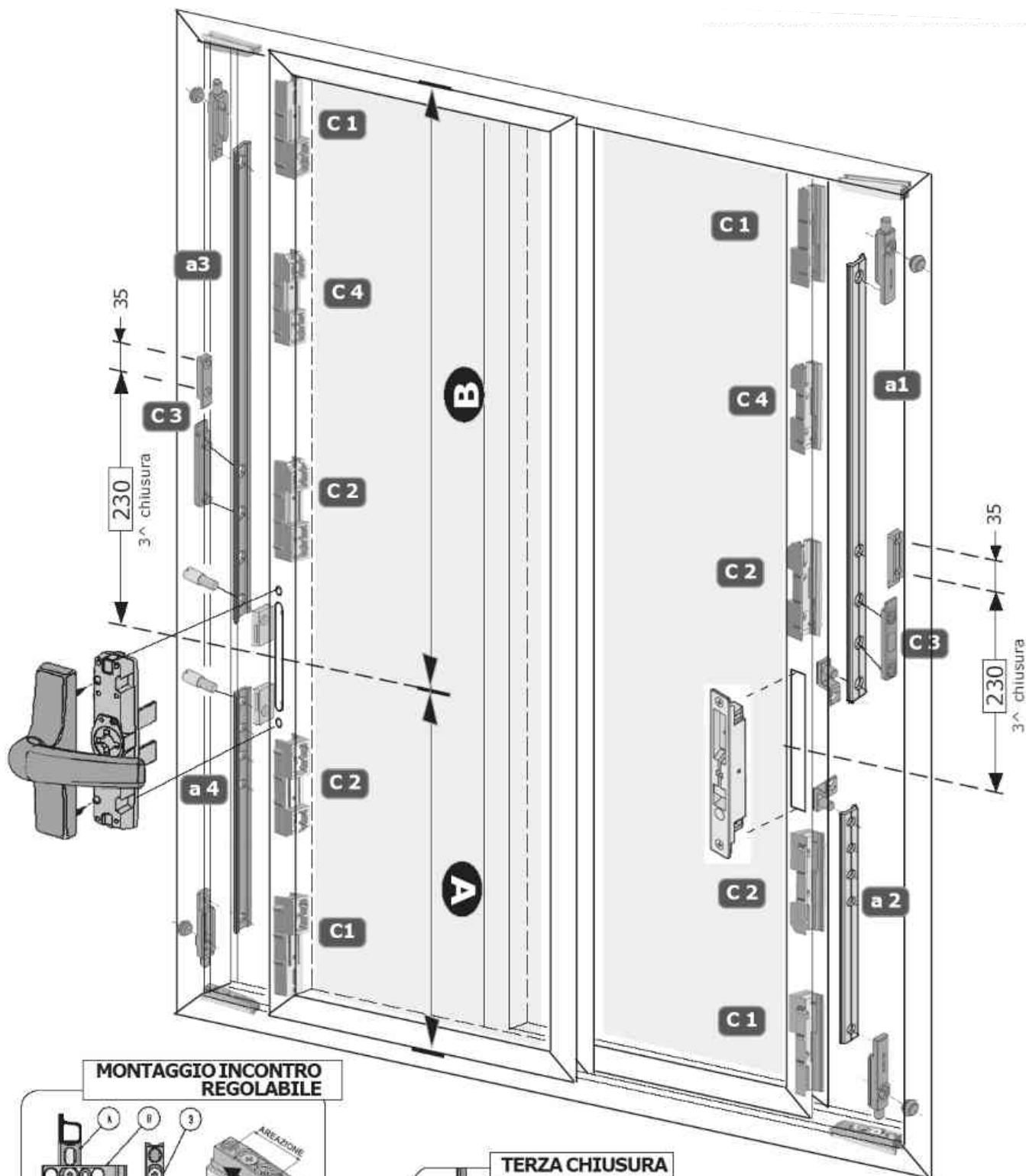

MONTAGGIO INCONTRO REGOLABILE

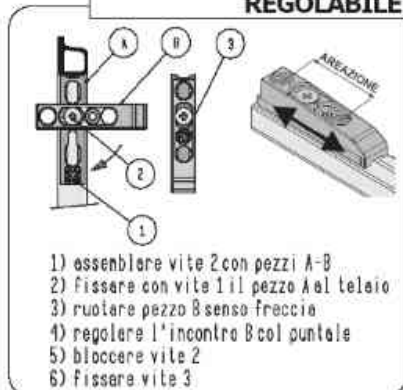

- 1) assemblare vite 2 con pezzi A-B
- 2) fissare con vite 1 il pezzo A al telaio
- 3) ruotare pezzo B senso freccia
- 4) regolare l'incontro B col puntale
- 5) bloccare vite 2
- 6) fissare vite 3

TERZA CHIUSURA

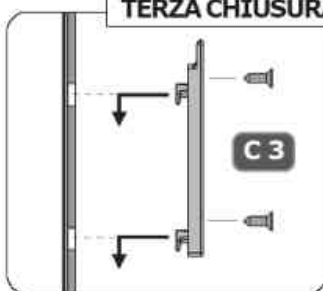

Per il profilo WIN 65S, cambiano solo i particolari C1, che si trovano nell'articolo specifico. Tutte le quote e le indicazioni di montaggio non cambiano.

PER IL MONTAGGIO DEGLI ACCESSORI NON INDICATI VEDI PAG. F8-65s-B.01
FOR ACCESSORY MOUNTING NOT INDICATED SEE PAG. F8-65s-B.01

A= DISTANZA PARTE INF.SCORREVOLE-ASSE MANIGLIA **B**= DISTANZA PARTE SUP.SCORREVOLE-ASSE MANIGLIA
TUTTE LE QUOTE E LE MISURE INDICATE SONO ESPRESSE IN mm

1 TAGLI ASTE DI COLLEGAMENTO

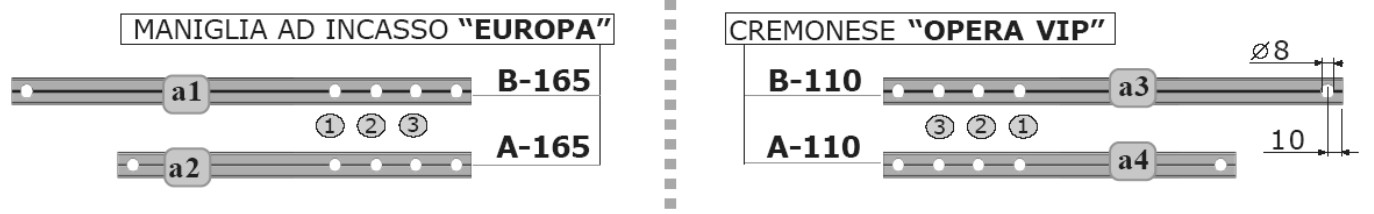

2 LAVORAZIONI SU SCORREVOLE PER INSERIMENTO MANIGLIA

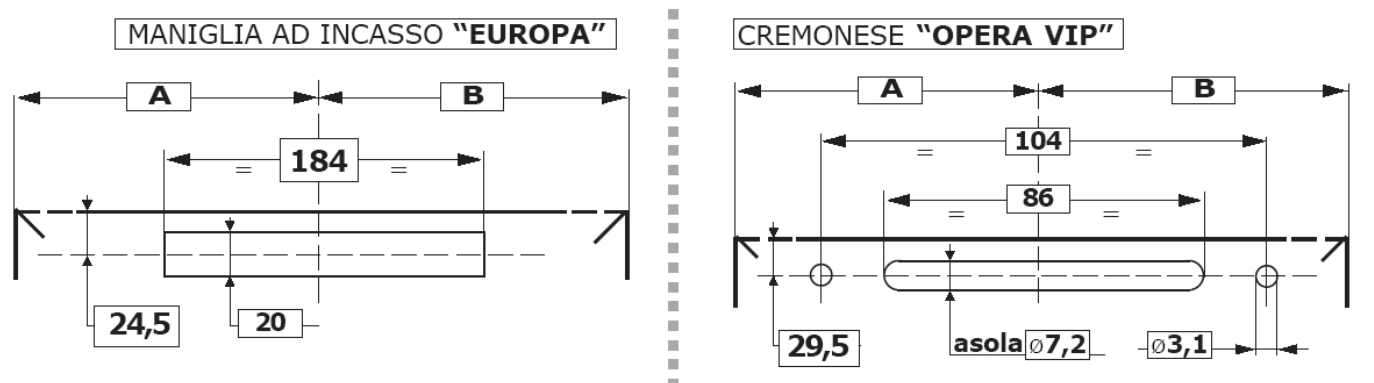

3 INSERIMENTO E FISSAGGIO COMPENSATORI (prima di assemblare l'anta)
ASSE MANIGLIA e CREMONESE

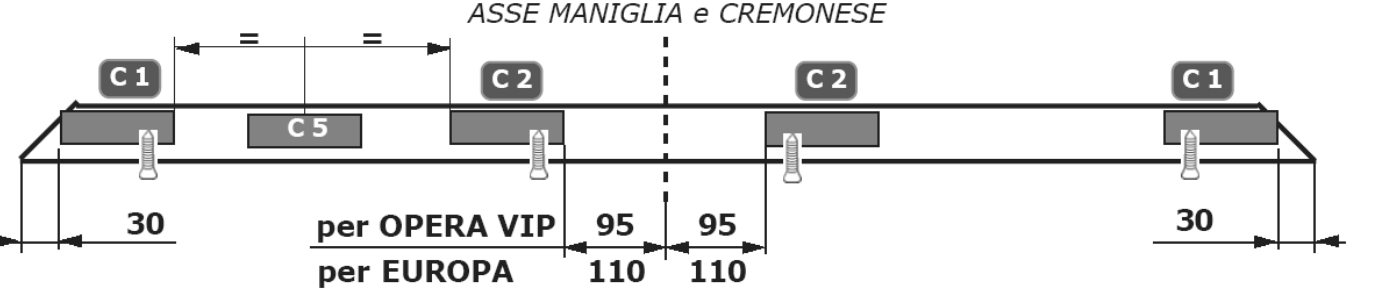

MANIGLIA AD INCASSO "EUROPA"

- 4** Fissare la maniglia EUROPA allo scorrevole.
- 5** Inserire i rinforzi angolari **C4** nei compensatori **C1**, fissare con la vite in dotazione (M4x10).
- 6** Inserire le aste **a1** e **a2**, assemblando alle estremità i puntali.
- 7** Fissare, con le viti (M6x14) e le staffe in dotazione, le aste alla maniglia.
- 8** Fissare la terza chiusura **C3** sull'asta **a1**, utilizzando i fori 2 e 3, vedi tagli aste. (E' possibile fissare la terza chiusura anche a infisso finito).
- 9** Una volta completato l'assemblaggio dei profili anta, fissare i rinforzi angolari ai profili orizzontali anta con la vite in dotazione. (vedi **C4**).

CREMONESE "OPERA VIP"

- 4** Fissare la cremonese OPERA VIP allo scorrevole, inserendo i blocchetti-giunzione.
- 5** Inserire i rinforzi angolari **C4** nei compensatori **C1**, fissare con la vite in dotazione (M4x10).
- 6** Inserire le aste **a3** e **a4**, assemblando alle estremità i puntali.
- 7** Fissare, con i perni e i blocchetti in dotazione, le aste alla cremonese.
- 8** Fissare la terza chiusura **C3** sull'asta **a3**, utilizzando i fori 1 e 2, vedi tagli aste. (E' possibile fissare la terza chiusura anche a infisso finito).
- 9** Una volta completato l'assemblaggio dei profili anta, fissare i rinforzi angolari ai profili orizzontali anta con la vite in dotazione. (vedi **C4**).

PER IL MONTAGGIO DEGLI ACCESSORI NON INDICATI VEDI PAG. F8-65s-B.01
FOR ACCESSORY MOUNTING NOT INDICATED SEE PAG. F8-65s-B.01

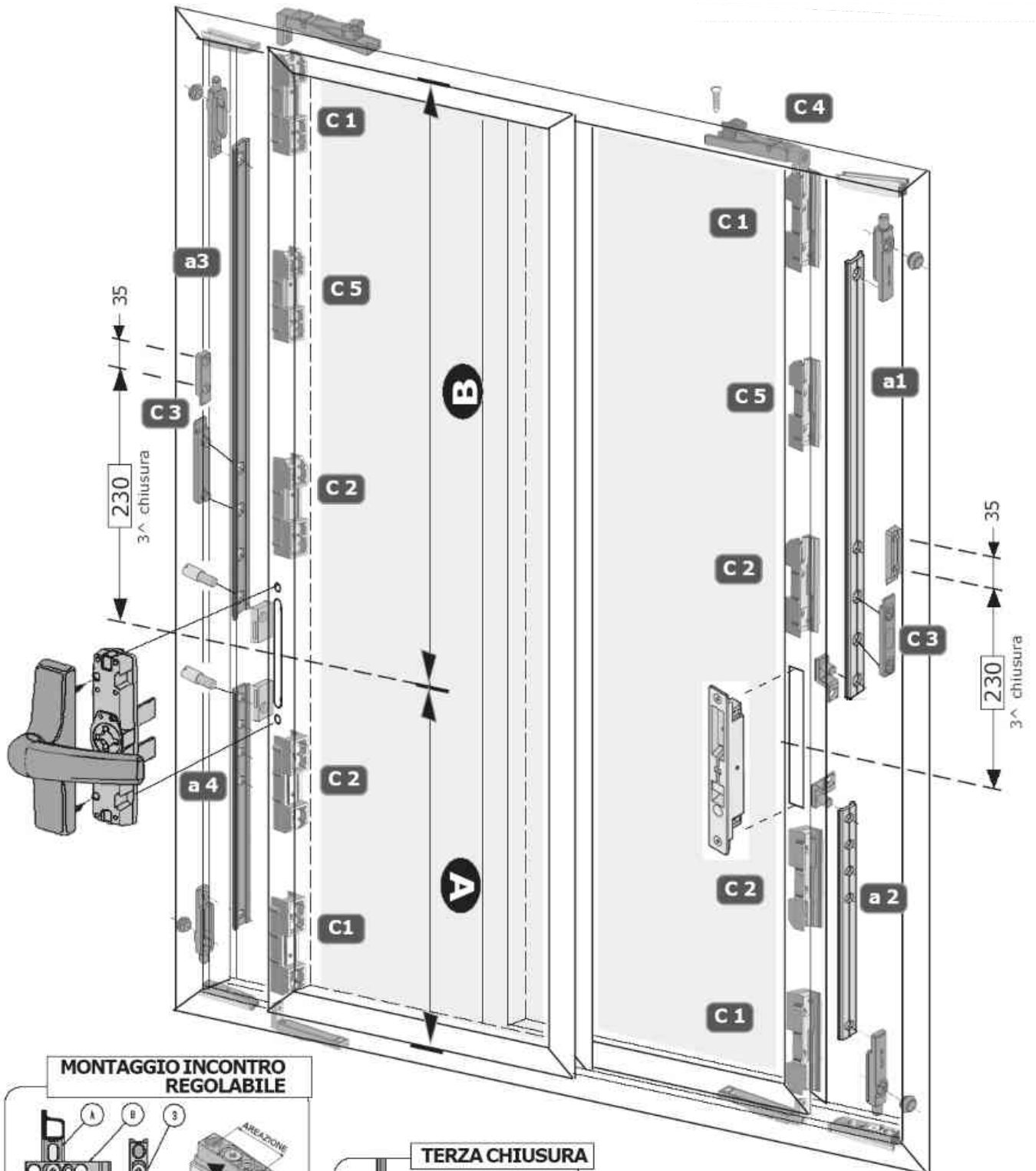

MONTAGGIO INCONTRO REGOLABILE

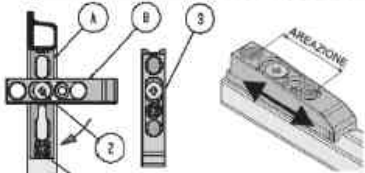

- 1) assemblare vite 2 con pezzi A-B
- 2) fissare con vite 1 il pezzo A al telaio
- 3) ruotare pezzo B senso frecce
- 4) regolare l'incontro B col puntale
- 5) bloccare vite 2
- 6) fissare vite 3

TERZA CHIUSURA

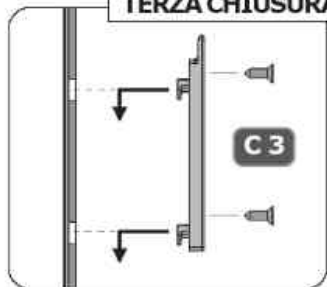

ANGOLO DI RINFORZO CON ANTISOLLEVAMENTO

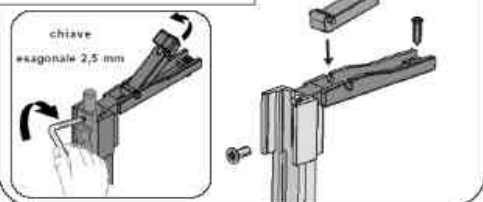

PER IL MONTAGGIO DEGLI ACCESSORI NON INDICATI VEDI PAG. F8-65s-B.01
FOR ACCESSORY MOUNTING NOT INDICATED SEE PAG. F8-65s-B.01

Sapa sviluppa, produce e commercializza in tutto il mondo profili a valore aggiunto. Sapa si avvale di oltre 13.000 dipendenti e centri di produzione in 30 paesi che collaborano per soddisfare tutte le esigenze dei clienti dei mercati più disparati.

Sapa Profili srl sviluppa, produce e commercializza profili per l'edilizia sempre innovativi. Original Systems garantisce una vasta e completa gamma di soluzioni residenziali e non, per rispettare le normative e per soddisfare le esigenze più complesse del mercato dell'involucro edilizio. I marchi di Original Systems, Sistema RTT, Sistema R, Teknowall, Teknowindow ed Alfil, sono distribuiti solo attraverso la rete Ufficiale di Distributori Sapa.

sapa: ... e scegli con serenità.